

Museum Handbook Quick Reference

1a6 and 1b2D.....	MH-I, Ch 12, E
.....	MH-I, App F, B (1a6 only)
36 CFR 2.5.....	MH-II, Ch 4, Sec VI
.....	MH-II, App H, D [in review]
Abandonment, deaccessioning.....	MH-II, Ch 6, I
Access and use legislation.....	MH-III, Ch 2, B
Access and use of museum collections, evaluating and documenting.....	MH-III, Ch 1
Accession book.....	MH-II, Ch 2, U
Accessioning.....	MH-II, Ch 2
Accessioning archives.....	MH-II, App D, G
Accessions inventory.....	MH-II, Ch 4, Sec I, D–E
Accountable officer, responsibilities.....	MH-II, Ch 1, E
Accreditation.....	MH-I, App B
Accretion (archives cataloging).....	MH-II, App D, G
ACP (Automated Checklist Program), Checklist for Preservation and Protection.....	MH-I, Ch 12, B
.....	MH-I, App F
AIP (Automated Inventory Program).....	MH-II, Ch 4, Sec I, A–B
Air pollution, effect on museum objects.....	MH-I, Ch 4, H–I
All Taxa Biodiversity Inventory (ATB).....	MH-II, App H, C [in review]
ANCS+ [ICMS].....	MH-II, Ch 1, A
Animal specimens.....	MH-I, App T
Appraising archival collections.....	MH-II, App D, E
Appraising museum objects.....	MH-II, Ch 4, Sec IX, D–G
Archeology collections, description.....	MH-I, Ch 1, F
Archeology object names.....	MH-II, App E, B
.....	MH-II, App E, E
Archeology objects, care of.....	MH-I, App I
Archeology objects, cataloging.....	MH-II, App E, C
Archeology objects, classifying.....	MH-II, App E, A
Archeology objects, lot cataloging.....	MH-II, App I, B
Archival collections, care of.....	MH-II, App D, N–Q
Archival collections, cataloging.....	MH-II, App D, C
.....	MH-II, App D, R
Archival collections, description.....	MH-I, Ch 1, E
.....	MH-II, App D
Archives and manuscript collections.....	MH-II, App D
ARPA (<i>Archeological Resources Protection Act</i>).....	MH-III, Ch 2, E
<i>Art and Architecture Thesaurus (AAT)</i>	MH-II, App G, B
Associated records for natural history specimens.....	MH-II, App H, M–P [in review]
Audit of museum property.....	MH-II, Ch 4, Sec I, H
Automated Checklist Program (ACP), Checklist for Preservation and Protection.....	MH-I, Ch 12, B
.....	MH-I, App F
Automated Inventory Program (AIP).....	MH-II, Ch 4, Sec I, A–B
Backlog cataloging funding.....	MH-II, App B
Bibliography.....	MH-II, App L
Bioblitz.....	MH-II, App H, C [in review]
Biological collections, care of.....	MH-I, App T
.....	MH-I, App Q, C–E
Biological infestations.....	MH-I, Ch 5
Bioprospecting.....	MH-II, App H, C [in review]]
Board of Survey.....	MH-II, Ch 4, Sec I, G
Board of Survey procedures.....	MH-II, Ch 6, I
Botanical collections, care of.....	MH-I, App Q, C–E
.....	MH-I, App T
Casts, cataloging.....	MH-II, App H, L [in review]
Cataloging by lot.....	MH-II, App I

Cataloging component parts	MH-II, App C, B
Cataloging costs	MH-II, App B
Cataloging guidelines	MH-II, App C
Cataloging museum objects	MH-II, Ch 3
.....	MH-II, App C
Cataloging—see by discipline	
Cellulose, nitrate and ester	MH-I, App M
Ceramic objects, care of	MH-I, App P
Checklist for Preservation and Protection (ACP)	MH-I, Ch 12, B
.....	MH-I, App F
Clearinghouse	MH-II, Ch 6, O
CMR (Collections Management Report)	MH-I, Ch 12, B
.....	MH-II, Ch 4, Sec VIII
Code of Ethics	MH-I, App D
Collection Condition Survey	MH-I, Ch 3, D
Collection Management Plan (CMP)	MH-I, Ch 3, C
.....	MH-I, App F, C
Collection permits for natural history specimens	MH-II, Ch 4, Sec VI
.....	MH-II, App H, D [in review]
Collection Storage Plan	MH-I, Ch 7, C
Collections Advisory Committee (role of)	MH-I, Ch 2, C
Collections Advisory Committee (role in deaccessions)	MH-II, Ch 6, D
Collections Management Report (CMR)	MH-I, Ch 12, B
.....	MH-II, Ch 4, Sec VIII
Collections management, responsibilities, policy	MH-I, Ch 1, H
Component parts, cataloging	MH-II, App C, B
Composite samples, classifying	MH-II, App H, L [in review]
Condition, standard terms	MH-II, App C, D
Conservation associations	MH-I, App C, D
Conservation of ceramic objects	MH-I, App P, F–H
Conservation of furniture, wooden objects	MH-I, App N, G–H
Conservation of glass objects	MH-I, App P, F–H
Conservation of leather and skin objects	MH-I, App S, D–F
Conservation of metal objects	MH-I, App O, F
Conservation of paintings	MH-I, App L, G
Conservation of paper objects	MH-I, App J, H
Conservation of photographic collections	MH-I, App R, D–I
Conservation of stone objects	MH-I, App P, F–H
Conservation of textiles	MH-I, App K, M
Conservation treatment	MH-I, Ch 8
Consumptive use of collections	MH-II, Ch 4, Sec V
.....	MH-III, Ch 1, C
Container Lists	MH-II, App D, L
.....	MH-II, App D, Fig. D6
Containers for storing museum collections	MH-I, Ch 7, H
Controlled property inventory	MH-II, Ch 4, Sec I, C
Conveyance of museum objects	MH-II, Ch 6, B
Cooperative Research and Development Agreement (CRADA)	MH-II, App H, D [in review]
Copyright, acquiring	MH-II, Ch 2, E
Copyright issues	MH-II, App D, X
Copyright laws	MH-III, Ch 2, C
Corrosion of metal objects	MH-I, App O, C
.....	MH-I, App O, Fig. O.2
Cost estimates for checklist deficiencies	MH-I, App F, Fig. F.1
Costume collections, storing and exhibiting	MH-I, App K, H–I, L
CRADA (Cooperative Research and Development Agreement)	MH-II, App H, D [in review]

Cultural groups	MH-II, App F, D
Cultural issues, use of collections	MH-III, Ch 1, E
Custodial officer, responsibilities	MH-II, Ch 1, E
Dataloggers	MH-I, Ch 4, E
Deaccessions	MH-II, Ch 6
Describing museum objects, methods and terminology	MH-II, App C, C–D
Destructive analysis, deaccessioning	MH-II, Ch 6, M
Deterioration, chemical and physical	MH-I, Ch 4, B
Digital images of museum objects	MH-II, App K, A
Director's Order #24	MH-II, App A, Fig. A.3
DNA samples, cataloging and preserving	MH-II, App H, L [in review]
Donor restrictions	MH-III, Ch 2, G
EAD (Encoded Archival Description)	MH-II, App D, T
Educational use of museum objects	MH-III, Ch 6, H
Emergency management for museum collections	MH-I, App G, E
Emergency Operations Plan (EOP)	MH-I, Ch 9, E
.....	MH-I, Ch 10, E
Emergency planning	MH-I, Ch 10
Endangered and threatened species	MH-II, App H, C [in review]
Entomology collections, care of	MH-I, App Q, C–E
.....	MH-I, App T
Environment, museum collections	MH-I, Ch 4
Environmental research collections, description	MH-I, App Q, C–E
Environmental samples	MH-II, App H, L [in review]
EOP (Emergency Operations Plan)	MH-I, Ch 9, E
.....	MH-I, Ch 10, E
Equipment, museum	MH-II, Ch 1, D
Ethical issues, use of collections	MH-III, Ch 1, D
Ethics and standards	MH-I, Ch 1, J
.....	MH-I, App D
Ethnology classification	MH-II, App F, A
Ethnology collections, description	MH-I, Ch 1, F
Ethnology object names	MH-II, App F, B
Ethnology objects, cataloging	MH-II, App F, C
Ethnology objects, lot cataloging	MH-II, App I, B
Exchanges of museum objects	MH-II, Ch 2, J–K
Exhibition aids	MH-II, Ch 4, Sec IV, C
Exhibits, designing, producing, and maintaining	MH-III, Ch 7
Fibers, types of	MH-I, App K, B
Field collections	MH-II, Ch 2, N–O
File unit in archives cataloging	MH-II, App D, K
Film, care of	MH-I, App M
Film, reformatting nitrate, cellulose acetate, diacetate, triacetate	MH-I, App M, C
Filming in museum spaces	MH-III, Ch 6, C–D
Finding aids	MH-II, App D, M and T
.....	MH-II, App D, Fig. D6
Fire protection	MH-I, Ch 9
Fire protection and security standards	MH-I, App G, B
Folder lists	MH-II, App D, K
Forms, museum	MH-II, Ch 1, D, H
Fossils, cataloging	MH-II, App H, L [in review]
Fossils, types of	MH-I, App U, B–D
Freedom of Information Act (FOIA)	MH-II, App D, V
.....	MH-III, Ch 2, D
Funding for backlog cataloging	MH-II, App B, B
Funding needs and requests	MH-I, Ch 12
Funding organizations	MH-I, App C, F

Funding sources.....	MH-I, Ch 12, D
Furniture, care of.....	MH-I, App N
Geological collections, care of	MH-I, App Q, C–E
.....	MH-I, App U, Sec. II
Gifts as accessions	MH-II, Ch 2, F–G
Glass objects, care of.....	MH-I, App P
GPRA goals	MH-I, Ch 12, E
.....	MH-I, App F, B (1a6 only)
Handling museum objects.....	MH-I, Ch 6, B
Hazardous materials and contamination, use of collections	MH-III, Ch 1, C
Hazardous materials, deaccessioning	MH-II, Ch 6, I
Hazardous substances, chemicals, objects, exposure to	MH-I, Ch 11, C–E
HCO (Hierarchical Classification Outline)	MH-II, App H, J [in review]
Health and safety issues, laws, and resources	MH-I, Ch 11
.....	MH-I, App H
Herbarium unit.....	MH-II, App H, H [in review]
Hierarchical Classification Outline (HCO)	MH-II, App H, J [in review]
Hierarchy in archival collections.....	MH-II, App D, D; MH-II, App D, I
Historic structures and museum objects	MH-III, Ch 8
History collections, description.....	MH-I, Ch 1, F
History object, names.....	MH-II, App G, B; MH-II, App G, E
History objects, cataloging	MH-II, App G, C
History objects, classification	MH-II, App G, A; MH-II, App G, D
History objects, lot cataloging	MH-II, App I, B
History of NPS Museums	MH-I, Ch 1, C
Housekeeping	MH-I, Ch 13
Housing museum objects.....	MH-I, Ch 7, G
Hybrids, natural history specimens	MH-II, App H, K [in review]
Hygrometers.....	MH-I, Ch 4, E
Hygrothermographs	MH-I, Ch 4, E
ICMS [ANCS+]	MH-II, Ch 1, A
Illicit trade	MH-II, Ch 2, D
Incoming loans	MH-II, Ch 2, P–T
Inherent vice.....	MH-I, Ch 4, B
Insurance for incoming loans	MH-II, Ch 4, Sec VII
Insurance for outgoing loans.....	MH-II, Ch 5, C; MH-II, Ch 5, E
Integrated Pest Management (IPM).....	MH-I, Ch 5, D
Integrated Taxonomic Information System (ITIS)	MH-II, App H, L [in review]
International Council of Museums (ICOM) Code of Professional Ethics	MH-III, Ch 1, D
Interpretation issues, use of collections	MH-III, Ch 1, H
Inventory and Monitoring Program (I&M).....	MH-I, Ch 1, G
.....	MH-II, App H, C [in review]
Inventory of museum property	MH-II, Ch 4, Sec I
Invertebrate collections, care of	MH-I, App T
Invertebrate specimens.....	MH-I, App Q, C–E
Involuntary destruction and deaccessioning	MH-II, Ch 6, I
ITIS (Integrated Taxonomic Information System)	MH-II, App H, L [in review]
Journals and technical Publications	MH-I, App C, D
Labels, natural history	MH-II, App J, K
.....	MH-II, App H, Q–R [in review]
Land Survey System	MH-II, App H, G [in review]
Laws and mandates	MH-I, Ch 1, B
.....	MH-I, App A
.....	MH-II, App A
Leather objects, care of.....	MH-I, App S
Legal issues	MH-III, Ch 2

Lichens, classifying	MH-II, App H, L [in review]
Light levels for museum objects	MH-I, Ch 4, F–G
Living history items	MH-II, Ch 4, Sec IV, B
Loans, incoming	MH-II, Ch 2, P–T
Loans, outgoing	MH-II, Ch 5
Location information	MH-II, Ch 4, Sec II
Longitude and latitude coordinate system	MH-II, App H, G [in review]
Loss of museum objects, deaccessioning	MH-II, Ch 6, I
Loss of museum objects, reporting	MH-II, Ch 4, Sec III
Lot cataloging	MH-II, App I
Lot cataloging natural history specimens	MH-II, App H, H [in review]
Manuscript collections	MH-II, App D
MARC-AMC (Machine Readable Cataloging Record— Archival and Manuscripts Control Format)	MH-II, App D, T
Marking museum objects	MH-II, App J
Measuring museum objects	MH-II, App C, E–F
Metal objects, care of	MH-I, App O
Metals, identifying	MH-I, App O, Fig. O.1
Monitoring equipment	MH-I, Ch 4, E
Moving museum objects	MH-I, Ch 6, C
<i>Museum Act of 1955</i>	MH-II, App A
Museum collection storage	MH-I, Ch 7
Museum Collections Emergency Operations Plan (MCEOP)	MH-I, Ch 10, E
Museum Housekeeping Plan	MH-I, Ch 13
Museum records	MH-II, Ch 1
NAGPRA collections, storing	MH-I, Ch 7, I
.....	MH-I, App I
NAGPRA in the SOCS	MH-I, Ch 2, F
NAGPRA collections, deaccessioning for repatriation	MH-II, Ch 6, N
NAGPRA, use of collections	MH-III, Ch 1, E
National Catalog	MH-II, Ch 3, G–H
National Historic Preservation Act	MH-III, Ch 2, E
National Parks Omnibus Management Act of 1998	MH-III, Ch 2, E
Native American cultural groups	MH-II, App F, D
Natural history collection permits	MH-II, App H, D [in review]
Natural history collections, accessions, deaccessions, loans	MH-II, App H, E [in review]
Natural history collections, care of	MH-I, App Q
Natural history collections, cataloging	MH-II, App H, F [in review]
Natural history collections, description	MH-I, Ch 1, G
.....	MH-I, App Q, C
Natural history collections, importance of	MH-II, App H, A [in review]
Natural history collections, lot cataloging	MH-II, App I, C
.....	MH-II, App H, H [in review]
Natural history collections, types of	MH-II, App H, B [in review]
Natural history collections, use of	MH-III, Ch 1, F
Natural history labels	MH-II, App J, K
.....	MH-II, App H, Q–R [in review]
Natural history specimens, collecting and laws and regulations	MH-II, App H, C [in review]
Nitrate film, care of	MH-I, App M
Nitrate negatives, destroying (not deaccessioning)	MH-II, Ch 6, C
Non-museum property, accessioned in error	MH-II, Ch 6, C
NPS–19 (Appendix B)	MH-II, App D, F
NPSpecies	MH-II, App H, F [in review]
Numbering museum objects	MH-II, App J
Operational policies and procedures	MH-I, Ch 9, E
Operations Formulation System (OFS)	MH-I, Ch 12, B
Orphan collections (natural history)	MH-II, App H, I [in review]

Outdoor exhibits	MH-II, Ch 4, Sec IV, D
Outgoing loans	MH-II, Ch 5
Outside Scope of Collection, deaccessioning	MH-II, Ch 6, J–L
Packing museum objects	MH-I, Ch 6, D–F
Paintings, care of	MH-I, App L
Paleontological collections, care of	MH-I, App Q, C–E
.....	MH-I, App U, Sec. I
Paper objects, care of	MH-I, App J
Patent laws and trademarks	MH-III, Ch 2, H–I
Performance Management Data System (PMDS)	MH-I, Ch 12, E
Performances using museum objects	MH-III, Ch 6, G
Permits for natural history specimens	MH-II, Ch 4, Sec VI
.....	MH-II, App H, D [in review]
Pests in museum collections	MH-I, Ch 5
Photographic collections, care of	MH-I, App R
Photographing museum objects	MH-II, App K
Photographs in archival collections	MH-II, App D, Q
Photographs of museum objects, documenting and storing	MH-II, App K, E
Planning for museum collections	MH-I, Ch 1, I
Plant specimens	MH-I, App T
Policy guidance	MH-I, Ch 1, H
.....	MH-I, App A
.....	MH-II, App A
Preservation issues, use of collections	MH-III, Ch 1, G
Preservation, collections and historic structures	MH-I, Ch 3
Privacy and publicity legislation	MH-III, Ch 2, F
Privacy issues, use of collections	MH-III, Ch 1, D
Professional organizations	MH-I, App C
Project Management Information System (PMIS)	MH-I, Ch 12, B
Protection of museum collections	MH-I, App G
Psychrometers	MH-I, Ch 4, E
Publications glossary	MH-III, App A
Publications, use of museum collections	MH-III, Ch 3
Purchasing museum objects	MH-II, Ch 2, H–I
Random sample inventory	MH-II, Ch 4, Sec I, C
Recataloging	MH-II, Ch 3, G
Records schedule	MH-II, App D, F
Records, museum	MH-II, Ch 1
Regional offices, responsibilities	MH-I, Ch 1, H
Regulations and standards for collections	MH-I, App A
Relative humidity, controlling	MH-I, Ch 4, D–E
Repatriation, deaccessioning NAGPRA collections	MH-II, Ch 6, N
Report of Survey (DI–103)	MH-II, Ch 4, Fig. 4.5
.....	MH-II, Ch 6, I
Repositories for natural history collections	MH-II, App H, I [in review]
<i>Repository Agreement for Natural History Specimens (Sample)</i>	MH-II, App H, App 2 [in review]
Reproductions	MH-II, Ch 4, Sec IV, A
Research Permit and Reporting System (RPRS)	MH-II, App H, D [in review]
Research permit application for natural history specimens	MH-II, App H, App 1[in review]
Research requests	MH-III, Ch 1, B
Research space, planning and guidance	MH-III, App D
Resource Management Plan	MH-I, Ch 12, B
Resource management records	MH-II, App D, M
Responsibilities of museum staff, use of collections	MH-III, Ch 1, D
Restricting use of collections	MH-III, Ch 1, C
Return to rightful owner, deaccessioning	MH-II, Ch 6, H

<i>Revised Nomenclature for Museum Cataloging</i> (1988)	MH-II, App G, A–B
RPRS (Research Permit and Reporting System)	MH-II, App H, D [in review]
Scholarly integrity	MH-III, Ch 1, D
Scientific names	MH-II, App H, K [in review]
Scientific research and collecting	MH-II, App H, D [in review]
Scope of Collections Statement	MH-I, Ch 2, C: MH-I, App E
Security and fire protection standards	MH-I, App G, B
Security and security systems	MH-I, Ch 9
Security issues, use of collections	MH-III, Ch 1, G
Sensitive information, access to	MH-III, Ch 2, G
Shipping museum objects	MH-I, Ch 6, D–G
Skin, care of objects made from	MH-I, App S
Special events in museum spaces	MH-III, Ch 6, E
Specimen labels	MH-II, App J, K
	MH-II, App H, Q–R [in review]
Spot-check inventory	MH-II, Ch 4, Sec I, H
Staffing	MH-I, Ch 12, F
Standard Operating Procedures for museums	MH-I, App G, D
Stone objects, care of	MH-I, App P
Storage containers	MH-I, Ch 7, H
Storage equipment	MH-I, Ch 7, G
Storage of museum collections, standards and requirements	MH-I, Ch 7, B
Structural fire management	MH-I, Ch 9
	MH-I, App G
Supplies, museum	MH-II, Ch 1, D
Surveys, museum security and fire protection	MH-I, App G, C
Tagging museum objects	MH-II, App J, K
Taxonomic Serial Number (TSN)	MH-II, App H, L [in review]
Taxonomy and classification	MH-II, App H, J [in review]
Temperature, controlling	MH-I, Ch 4, C–E
Textiles, care of	MH-I, App K
Theft, deaccessioning	MH-II, Ch 6, I
Theft, reporting	MH-II, Ch 4, Sec III
Three-dimensional reproductions	MH-III, Ch 5
Tissue samples, cataloging and preserving	MH-II, App H, L [in review]
Tort claim	MH-II, Ch 4, Sec VII, A
Trace fossils, cataloging	MH-II, App H, L [in review]
Trademarks and servicemarks	MH-III, Ch 2, I
Training and development	MH-I, Ch 12, G
Training, museum documentation	MH-II, Ch 1, B
Transfer of museum objects	MH-II, Ch 2, L–M
	MH-II, Ch 6, J
TSN (Taxonomic Serial Number)	MH-II, App H, L [in review]
Two-dimensional reproductions	MH-III, Ch 4
Unpacking museum objects	MH-I, Ch 6, H
UTM coordinate system	MH-II, App H, G [in review]
Value of museum objects	MH-II, Ch 4, Sec IX
Vertebrate collections, care of	MH-I, App Q, C–E
	MH-I, App T
Voluntary destruction, deaccessioning	MH-II, Ch 6, I
Voucher specimen	MH-II, App H, J [in review]
Washington Office, responsibilities	MH-I, Ch 1, H
Wet specimens	MH-I, App T, Sec. IV
Wooden objects, care of	MH-I, App N

MUSEUM HANDBOOK



PART I MUSEUM COLLECTIONS

ACKNOWLEDGMENTS

The preparation of the NPS *Museum Handbook*, Part I, is coordinated by the Preservation and Protection Team, Museum Management Program.

The entire Handbook was reissued in 1990. Additional revisions were issued in 1994, 1996, 1998, 1999, 2000, 2001, 2002, 2003, 2005 and 2006. Additional Plain Language revisions and updates are currently being prepared. The authors and the date each chapter or appendix was issued or revised are listed below:

Chapter 1 (2006) – Ann Hitchcock, Chief Curator; Steve Floray, Museum Specialist, Park Museum Management Program.

Chapter 2 (2003) – Steve Floray, Museum Specialist, Park Museum Management Program; Tony Knapp, Training Manager, Cultural Resources Stewardship, Stephen T. Mather Training Center.

Chapter 3 (1999) – Jessica S. Johnson, Conservator, Museum Management Program and Martin Burke, Associate Manager, Department of Conservation, Harpers Ferry Center.

Chapter 4 (1999) – Jessica S. Johnson, based on 1990 version. The previous version was written by Edward McManus, Regional Conservator, North Atlantic Region; Tom Carter, Paintings Conservator, Division of Conservation, Harpers Ferry Center; Diana Pardue, Staff Curator, Curatorial Services Division; John Hunter, Supervisory Staff Curator, Curatorial Services Division; and Toby Raphael, Conservator, Division of Conservation, Harpers Ferry Center.

Chapter 5 (1998) – Jessica S. Johnson.

Chapter 6 (1999) – Jessica S. Johnson, based on the 1990 version written by Kathleen Byrne, Staff Curator, Curatorial Services Division.

Chapter 7 (1999) – Donald Cumberland, Museum Specialist, Museum Management Program, with additions by Steve Floray, Museum Specialist, Museum Management Program (2001).

Chapter 8 (2001) – Sara J. Wolf, Conservator, Museum Management Program, and Jessica S. Johnson.

Chapter 9 (2002) – Danny McDaniel, Director, Security, Safety and Transportation, The Colonial Williamsburg Foundation; John Hunter; Tony Knapp; with additions by Steve Floray and Sara J. Wolf.

Chapter 10 (2000) – Diane Vogt O'Connor, Senior Archivist, Museum Management Program.

Chapter 11 (2001) – Jessica S. Johnson based on the 1990 version written by Tony Knapp; Bill Meuse, Museum Curator, Springfield Armory NHS; Bart Roberts, Metals Conservator, Division of Conservation, Harpers Ferry Center.

Chapter 12 (2003) – Abby Sue Fisher, Chief of Museum Services, Keweenaw National Historical Park; Sara J. Wolf.

Appendix A (2000) – Steve Floray, based on the 1990 version written by Tony Knapp.

Appendix B (2006) – Ann Hitchcock.

Appendix C (2000) – Steve Floray, based on the 1990 version written by Tony Knapp.

Appendix D (2006) – Ann Hitchcock.

Appendix E (2003) – Steve Floray.

Appendix F (1999) – Jessica S. Johnson, with additions by Steve Floray (2005).

Appendix G (1996) – Danny McDaniel; John Hunter; Tony Knapp.

Appendix I (2001) – Cynthia Murdock, Program Assistant, Museum Management Program, and Jessica S. Johnson, based on the 1999 version written by Brigid Sullivan, Regional Conservator, Midwest Region.

Appendix J (2003) – Sara J. Wolf.

Appendix K (2002) – Sara J. Wolf.

Appendix L (2000) – Jessica S. Johnson and Karen Bennett, Intern, Museum Management Program, based on the 1990 version written by Tom Carter.

Appendix M (1999) – Diane Vogt O'Connor.

Appendix N (2002) – Cynthia Murdock, based on the 1990 version written by Al Levitan, Furniture Conservator, Division of Conservation, Harpers Ferry Center.

Appendix O (2002) – Martin Burke.

Appendix P (2000) – Jessica S. Johnson, based on the 1990 version written by Shelley Sturman, Objects Conservator, and Judy Ozone, Objects Conservator, National Gallery of Art.

Appendix Q (1999) – Catherine Hawks, Private Conservator.

Appendix R (1996) – Debbie Hess Norris, Assistant Professor of Photographic Conservation, University of Delaware, and President of the American Institute for Conservation of Historic and Artistic Works.

Appendix S (1996) – Toby Raphael.

Appendix T (2005) - Stephen L. Williams, Assistant Professor of Museum Studies, Baylor University and Collections Manager, Strecker Museum Complex (adapted from Mr. Williams' Ph.D. dissertation); Catherine Hawks.

Appendix U (2005) - Greg McDonald, Senior Curator of Natural History, Park Museum Management Program; Ann Elder, Paleontologist and Museum Curator, Dinosaur National Monument; Sally Shelton, Collections Officer, Smithsonian Institution, National Museum of Natural History.

Additional thanks go to the numerous other individuals who have assisted or advised on the Handbook since 1990. Individuals who assisted with the 1999, 2000, 2001, 2002, 2003, 2005 and 2006 revisions include: Carol diSalvo, Integrated Pest Management Coordinator, and Barbara Cumberland, Assistant Conservator, Department of Conservation, Harpers Ferry Center, for Chapter 5; Harold L. Spencer, Structural Fire Training and Education Specialist, National Interagency Fire Center, Structural Fire Program, for Chapter 9; Carol diSalvo and Kathryn Makos, Senior Industrial Hygienist, Smithsonian Institution, for Chapter 11; Nancy Purinton, Conservator, Department of Conservation, Harpers Ferry Center, for Appendix J; Sara McElroy, Paintings Conservator, University of Texas at Austin, for Appendix L.

Thanks to the following individuals for their critical review of the text: John W. Roberts, Chief National Register of Historic Places and National Historic Landmarks Program (former Manager, Park Museum Management Program); Joan Bacharach, Curator, Park Museum Management Program; Janet Pasiuk, Museum Technician, Clara Barton National Historic Site; Melinda Snarr, Intern, Park Museum Management Program; Museum Management Program Council members; NPS Chief Curator Ann Hitchcock. Additional thanks to Lea Anne Chapman, Program Assistant, Park Museum Management Program, and Cynthia Murdock for their careful copyediting and formatting of the text.

TABLE OF CONTENTS

	<u>Page</u>
INTRODUCTION	
1. NATIONAL PARK SERVICE MUSEUMS AND COLLECTIONS	
A. Purpose of National Park Service Museums	1:1
B. History of National Park Service Museums	1:4
C. National Park Service Museum Collections	1:11
D. Introduction to NPS Museum Collections Management	1:20
E. Planning for Park Museum Collections	1:23
F. Professional Considerations	1:29
G. Selected Bibliography	1:35
H. Endnotes	1:41
2. SCOPE OF MUSEUM COLLECTIONS (2003)	
A. Overview	2:1
B. Museum Collections	2:1
C. The Scope of Collection Statement	2:3
D. Writing the Introductory Section of the Scope of Collection Statement	2:6
E. Writing the Types of Collections Section	2:10
F. Writing the Museum Collections Subject to NAGPRA Section	2:17
G. Writing the Acquisition Section	2:18
H. Writing the Uses of Collections Section	2:20
I. Writing the Restrictions Section	2:22
J. Writing the Management Actions Section	2:24
K. Implementing the Scope of Collection Statement	2:25
L. Selected Bibliography	2:28
3. MUSEUM OBJECTS PRESERVATION: GETTING STARTED (1999)	
A. Introduction to Museum Objects Preservation	3:1
B. Establishing an Object Conservation Program	3:4
C. The Collection Management Plan	3:7
D. The Collection Condition Survey	3:10
E. The Structure that Houses Museum Objects	3:14
F. Glossary	3:15
G. Selected Bibliography	3:17
H. Endnotes	3:19
4. MUSEUM COLLECTIONS ENVIRONMENT (1999)	
A. The Agents of Deterioration	4:1
B. Developing the Critical Eye	4:4
C. Temperature and Relative Humidity	4:9
D. Monitoring and Controlling Relative Humidity and Temperature	4:15
E. Light	4:37
F. Dust and Gaseous Air Pollution	4:47
G. Selected Bibliography	4:56
H. Endnotes	4:58
5. BIOLOGICAL INFESTATIONS (1998)	
A. Overview	5:1
B. Active Infestations	5:1
C. Identification of Museum Pests	5:3
D. Integrated Pest Management (IPM)	5:7
E. Monitoring	5:9

	<u>Page</u>
F. Documenting and Evaluating Your IPM Program.....	5:14
G. Selected Bibliography.....	5:15
H. Web Information.....	5:15
6. HANDLING, PACKING AND SHIPPING MUSEUM OBJECTS (1999)	
A. Introduction.....	6:1
B. Handling Objects.....	6:2
C. Moving Objects Within the Museum.....	6:9
D. Packing and Shipping Preparations.....	6:11
E. Packing and Shipping Materials.....	6:13
F. Packing for Shipping.....	6:18
G. Shipping Objects.....	6:23
H. Receiving and Unpacking the Container.....	6:27
I. Selected Bibliography.....	6:28
7. MUSEUM COLLECTIONS STORAGE (1999)	
A. Overview.....	7:1
B. Standards and Requirements for Collection Storage.....	7:2
C. Planning Collection Storage Space.....	7:8
D. Assessing Collection Storage Needs.....	7:10
E. Assessing the Current Collection Storage Facility or Space.....	7:14
F. Planning a New or Upgraded Storage Space.....	7:16
G. Housing Museum Objects.....	7:19
H. Using Containers and Supports.....	7:21
I. Storage of Museum Collections Subject to the Native American Graves Protection and Repatriation act of 1990 (NAGPRA).....	7:22
J. Bibliography.....	7:25
K. List of Figures.....	7:28
8. CONSERVATION TREATMENT (2001)	
A. Overview.....	8:1
B. Factors to Consider Before Conservation Treatment.....	8:4
C. Documentation of Conservation Treatment.....	8:7
D. Obtaining the Services of a Conservator.....	8:12
E. Glossary.....	8:15
F. Selected Bibliography.....	8:16
G. Internet Resources.....	8:17
9. MUSEUM COLLECTIONS SECURITY AND FIRE PROTECTION (2002)	
A. Overview.....	9:1
B. Legal, Regulatory and Policy Requirements.....	9:3
C. Measuring the Effectiveness of a Security System.....	9:5
D. Fire Protection.....	9:11
E. Operational Security.....	9:23
F. Physical Security.....	9:31
G. Electronic Security Systems.....	9:35
H. Protecting Collections in Transit.....	9:45
I. Reporting and Recovering Stolen Museum Objects.....	9:46
J. Museum Collection Records.....	9:47
K. World Wide Web Resources.....	9:49
L. Selected Bibliography.....	9:49
M. Endnotes.....	9:50

10. MUSEUM COLLECTIONS: EMERGENCY PLANNING (2000)	
A. Overview	10:1
B. Museum Collections Hazards, Vulnerabilities and Disaster Prevention	10:3
C. Analysis of Risk to Your Park's Museum Collections	10:32
D. Prioritization of Museum Collections for Salvage	10:35
E. Preparation of a Museum Component to an Emergency Operations Plan	10:43
F. Staff Training and Plan Evaluation and Revision	10:50
G. Bibliography	10:52
H. List of Figures	10:57
11. CURATORIAL HEALTH AND SAFETY (2001)	
A. Overview	11:1
B. Understanding Health and Safety Issues	11:3
C. Controlling Exposure to Hazardous Substances	11:6
D. Hazardous Chemicals and Materials Used in Collections Care.....	11:11
E. Hazardous Objects in Collections	11:17
F. Safety Rules for Lifting and Carrying	11:26
G. Workspace Conditions.....	11:27
H. Glossary	11:29
I. Web Resources	11:30
J. Selected Bibliography	11:31
K. List of Figures	11:33
12. CURATORIAL FUNDING, STAFFING, AND REPORTING (2003)	
A. Overview	12:1
B. Basic Museum Program Management Issues	12:1
C. Developing Funding Requests	12:7
D. Sources of Funding for Collections Management.....	12:11
E. Documenting Results and Performance.....	12:16
F. Staffing.....	12:18
G. Training and Development	12:21
H. Resources	12:23
I. Figures	12:25
13. MUSEUM HOUSEKEEPING (1998)	
A. Overview	13:1
B. The Museum Housekeeping Plan.....	13:7
C. Selected Bibliography	13:13
D. List of Figures	13:15

APPENDICES

	<u>Page</u>
A. MANDATES AND STANDARDS FOR NPS MUSEUM COLLECTIONS MANAGEMENT (2000)	
A. Overview.....	A:1
B. Laws, Regulations, and Conventions – NPS Cultural Collections.....	A:1
C. Laws, Regulations, and Conventions – NPS Natural History Collections	A:6
D. Policies and Standards.....	A:9
E. List of Figures	A:16
B. ACCREDITATION (1998)	
A. Overview.....	B:1
B. Accreditation Step-by-Step.....	B:4
C. PROFESSIONAL ORGANIZATIONS AND SOCIETIES (2000)	
A. Overview.....	C:1
B. National Museum Organizations	C:1
C. Regional Museum Conferences and Associations	C:3
D. Regional Conservation Guilds and Associations.....	C:5
E. Museum Journals and Technical Publications	C:5
F. Funding Organizations	C:6
D. CODE OF ETHICS FOR CURATORS, ARCHIVISTS, AND CONSERVATORS	
A. American Association of Museums Code of Ethics for Curators.....	D:1
B. Society of American Archivists Code of Ethics for Archivists	D:2
C. American Institute for Conservation Code of Ethics and Standards of Practice for Conservators	D:4
E. SCOPE OF COLLECTION STATEMENT (2003)	
A. Overview.....	E:1
B. Evaluating Your Scope of Collection Statement.....	E:1
C. List of Figures	E:2
F. NPS MUSEUM COLLECTIONS MANAGEMENT CHECKLISTS (1999)	
A. NPS Checklist for Preservation and Protection of Museum Collections	F:1
B. NPS Collection Management Plan Team Site Visit Checklist.....	F:39
C. NPS Checklist of Reference Documents for Collection Management Plan Team	F:47
G. PROTECTION OF NATIONAL PARK SERVICE MUSEUM COLLECTIONS (1996)	
A. Overview.....	G:1
B. NPS Standards for Security and Fire Protection.....	G:1
C. Museum Security and Fire Protection Surveys.....	G:3
D. Park Museum Standard Operating Procedures and Agreements.....	G:6
E. Mandates and Requirements for Emergency Management for Museum Collections	G:8
F. Glossary	G:9
G. List of Figures	G:14
H. CURATORIAL HEALTH AND SAFETY (2000)	
A. Laws, Regulations, and NPS Policies and Guidelines.....	H:1
B. Sources of Assistance.....	H:2
C. Sources of Health and Safety Equipment and Supplies	H:5

I. CURATORIAL CARE OF ARCHEOLOGICAL OBJECTS (2001)	
A. Overview.....	I:1
B. Handling and Cleaning Archeological Materials.....	I:3
C. Storage Conditions for Archeological Objects.....	I:4
D. Storage Techniques for Archeological Collections.....	I:5
E. Selected Bibliography.....	I:8
J. CURATORIAL CARE OF PAPER OBJECTS (2003)	
A. Overview.....	J:1
B. The Nature of Paper Objects.....	J:3
C. Agents of Deterioration.....	J:5
D. Collections Maintenance.....	J:11
E. Handling Paper Objects.....	J:13
F. Storing Paper Objects.....	J:16
G. Exhibiting Paper Objects.....	J:23
H. Working with a Conservator When Treatment is Needed.....	J:24
I. Emergency Procedures for Paper Collections.....	J:26
J. Glossary of Terms Used to Describe Condition.....	J:27
K. Selected Bibliography.....	J:28
L. Selected World Wide Web Resources.....	J:29
K. CURATORIAL CARE OF TEXTILE OBJECTS (2002)	
A. Overview.....	K:1
B. The Nature of Textiles.....	K:2
C. The Fabrication of Textiles.....	K:5
D. Deterioration of Textiles.....	K:9
E. Proper Handling of Textiles.....	K:13
F. Storage Specifications.....	K:14
G. Storing Flat Textiles.....	K:15
H. Storing Costume Collections.....	K:17
I. Storing Costume Accessories.....	K:21
J. General Considerations for Exhibition.....	K:26
K. Exhibition of Flat Textiles.....	K:28
L. Display of Historic Costumes.....	K:33
M. Conservation Treatment.....	K:34
N. Packing and Shipping Textile Objects.....	K:39
O. Emergency Procedures for Textile Objects.....	K:40
P. Glossary.....	K:41
Q. Bibliography.....	K:42
R. Additional Resources.....	K:44
L. CURATORIAL CARE OF PAINTINGS (2000)	
A. Overview.....	L:1
B. The Nature of Canvas and Panel Paintings.....	L:2
C. Factors that Contribute to a Painting's Deterioration.....	L:5
D. Proper Handling and Storage of Paintings.....	L:9
E. Exhibiting Paintings.....	L:13
F. Proper Shipping of Paintings.....	L:14
G. Conservation Treatment.....	L:15
H. Procedures for Handling Paintings During Emergencies.....	L:17
I. Glossary of Terms Used for Condition Reporting When Examining Paintings.....	L:18
J. Selected World Wide Web References.....	L:19

	<u>Page</u>
K. Selected References	L:19
M. MANAGEMENT OF CELLULOSE NITRATE AND CELLULOSE ESTER FILM (1999)	
A. Overview.....	M:1
B. Identification and Evaluation of Historical Nitrate and Cellulose Ester Film	M:8
C. Management of Nitrate and Cellulose Ester Films	M:18
D. Prevention of Nitrate Fires	M:32
E. Bibliography.....	M:36
N. CURATORIAL CARE OF WOODEN OBJECTS (2002)	
A. Overview.....	N:1
B. The Nature of Wood	N:2
C. Agents of Deterioration	N:4
D. The Nature of Furniture	N:9
E. Preventive Conservation: Controlling the Environment.....	N:15
F. Preservation Through Good Housekeeping Practices	N:17
G. Preventive Conservation at Other Times.....	N:20
H. Conservation Treatment	N:23
I. Emergency Procedures for Wooden Objects.....	N:26
J. Selected Bibliography	N:28
O. CURATORIAL CARE OF METAL OBJECTS (2002)	
A. Overview.....	O:1
B. The Nature of Metals and Metal Objects.....	O:2
C. Factors that Contribute to Metal Object Deterioration.....	O:5
D. Proper Handling and Storage of Metal Objects.....	O:6
E. Exhibiting Metal Objects	O:8
F. Conservation Treatment	O:9
G. Emergency Procedures for Metal Objects.....	O:11
H. Special Considerations for Archeological Metal Objects.....	O:12
I. Glossary	O:12
J. Web Resources	O:15
K. Selected References	O:15
P. CURATORIAL CARE OF CERAMIC, GLASS, AND STONE OBJECTS (2000)	
A. Overview.....	P:1
B. The Nature of Ceramics Objects	P:1
C. The Nature of Glass Objects.....	P:6
D. The Nature of Stone Objects.....	P:8
E. Deterioration of Ceramics, Glass and Stone.....	P:10
F. Preventive Conservation.....	P:13
G. Care of Composite Ceramic and Glass Objects.....	P:19
H. Treatment Issues for Ceramic, Glass and Stone Objects	P:21
I. Packing and Shipping Glass, Ceramic, and Stone Objects.....	P:23
J. Emergency Procedures for Ceramic, Glass and Stone Objects.....	P:24
K. Selected Bibliography	P:25
Q. CURATORIAL CARE OF NATURAL HISTORY COLLECTIONS (1999)	
A. Overview.....	Q:1
B. The Nature of the Collections	Q:5
C. Natural History Collections	Q:7
D. Collecting and Preparation Techniques	Q:17
E. Labels and Labeling	Q:26

	<u>Page</u>
F. Glossary	Q:28
G. Selected References	Q:30
R. CURATORIAL CARE OF PHOTOGRAPHIC COLLECTIONS (1996)	
A. Overview	R:1
B. The Nature of Photographic Materials	R:1
C. Preparing a Preservation Strategy	R:5
D. Preventive Conservation: Handling Photographic Collections	R:11
E. Preventive Conservation: Storing Photographic Collections	R:15
F. Preventive Conservation: Housing Photographic Collections	R:19
G. Preventive Conservation: Exhibiting Photographic Collections	R:30
H. Preventive Conservation: Inspecting Photographic Collections	R:32
I. Conservation Treatment Issues for Deteriorated Photographic Materials	R:33
J. The Recovery of Water-Damaged Photographic Materials	R:40
K. Selected Bibliography	R:41
S. CURATORIAL CARE OF OBJECTS MADE FROM LEATHER AND SKIN PRODUCTS (1996)	
A. Overview	S:1
B. The Nature of Leather and Skin Products	S:2
C. Agents of Deterioration	S:7
D. Preventive Conservation: Guidelines for Leather and Skin Object Care, Handling, and Storage.....	S:12
E. Summary: Leather and Skin Product Deterioration and Preventive Care	S:19
F. Conservation Treatment Issues	S:20
G. Selected Bibliography	S:22
T. CURATORIAL CARE OF BIOLOGICAL COLLECTIONS (2005)	
Section I: The Nature of Biological Collections	T:1
A. Overview	T:1
B. Introduction to Biological Collections	T:1
Section II: Preservation of Biological Collections In General	T:13
A. Overview	T:13
B. Stabilization of Biological Specimens	T:13
C. Processing of Biological Specimens	T:17
D. Storage of Biological Collections	T:26
E. Maintenance of Biological Collections	T:40
Section III: Dry Biological Collections	T:46
A. Overview	T:46
B. Special Concerns for the Stabilization of Dry Specimens	T:55
C. Special Concerns for the Processing of Dry Biological Specimens	T:56
D. Special Maintenance Concerns for Dry Collections	T:57
Section IV: Wet Biological Collections	T:64
A. Overview	T:64
B. Stabilization of Wet Biological Specimens	T:68
C. Processing of Wet Biological Specimens	T:71
D. Storage of Wet Biological Collections	T:79
E. Maintenance of Wet Biological Collections	T:85
Section V: Biological Low-Temperature Collections	T:91
A. Overview	T:91
B. Stabilization and Processing of Low-Temperature Collections	T:95
C. Storage of Low-temperature Collections	T:100
D. Maintenance of Low-temperature Collections	T:107
Section VI: Biological Microscopy Collections	T:111
A. Overview	T:111

B. Stabilization and Processing of Microscopy Collections	T:116
C. Storage of Microscopy Collections	T:118
Section VII: Glossary	T:123
Section VIII: References	T:124
Section IX: Non-NPS Repositories with Servicewide or Multi-Regional Agreements to House Park Biological Collections	T:134

U. CURATORIAL CARE OF PALEONTOLOGICAL AND GEOLOGICAL COLLECTIONS (2005)

Section I: Paleontological Collections	U:1
A. Overview	U:1
B. Paleontological Collections and Fossils	U:2
C. Body Fossils	U:3
D. Trace Fossils	U:4
E. Factors That Contribute to Specimen Deterioration	U:5
F. Handling and Storage of Paleontological Specimens	U:9
G. Health and Safety Issues	U:15
H. Security and Fire Protection of Paleontological Collections	U:19
I. Exhibiting Paleontological Specimens	U:20
J. Preparation and Conservation of Specimens	U:22
Section II: Geological Collections	U:27
A. Overview	U:27
B. Geological Collections	U:28
C. Factors that Contribute to Specimen Deterioration.....	U:30
D. Handling and Storage of Geological Collections	U:32
E. Health and Safety Issues	U:34
F. Security Concerns	U:39
G. Exhibiting Geological Specimens.....	U:40
H. Conservation of Specimens	U:41
Section III. References	U:43
A. National Park Service Resources	U:43
B. Professional Organizations	U:43
C. Glossary	U:44
D. Web Resources	U:45
E. Bibliography	U:46

LIST OF FIGURES

Figure Number	Caption	Page
2.1	Example Scope of Collection Summary.....	2:29
2.2	Example Potential Museum Acquisitions Sheet	2:30
3.1	Curator and Conservator Roles in Object Conservation Management	3:5
4.1	The Agents of Deterioration.....	4:3
4.2	How to Use a Psychrometric Chart	4:12
4.3	Relative Humidity Optimum Ranges for Various Materials Housed in a Park's Museum Collection	4:14
4.4	Hygrothermograph Calibration Record	4:23
4.5	Hygrothermograph Chart that Illustrates the Relationship Between Temperature and Relative Humidity	4:25
4.6	Hygrothermograph Chart that Indicates Operation of Air Handling Equipment	4:26
4.7	Hygrothermograph Chart that Illustrates the Results of Turning Off the Furnace	4:27
4.8	Museum Environmental Monitoring Record	4:30
4.9	Maximum Acceptable Illuminance Level for Light Sensitive Materials	4:39
4.10	Light and Heat Measurement Record.....	4:44
4.11	Deterioration to Museum Objects Caused by Air Pollution	4:51
4.12	Materials Known to Release Harmful Vapors and Materials that Appear to be Safe.....	4:54
5.1	Sample Pest Identification Request Letter	5:16
5.2	Sample Museum Integrated Pest Management Survey Form	5:17
6.1	Proper handling techniques are essential to museum housekeeping practices.....	6:1
6.2	The use of equipment and supplies such as carts and trays minimizes the need to handle objects	6:2
6.3	Equipment and supplies for handling museum objects include trays, padding, tissue, gloves, and carts.....	6:3
6.4	A teapot should be handled by the base rather than by the handle or spout	6:5
6.5	Use two hands and clean white gloves when handling museum objects	6:6
6.6	How to lift properly and avoid injury	6:7
6.7	The proper way to lift a chair	6:8
6.8	The proper way to lift a small framed photograph.....	6:8
6.9	The proper way to lift and carry a small textile object	6:8
6.10	These pipe bowls were placed in individual specimen trays within a larger tray to prevent damage during movement	6:10
6.11	Pad moveable parts and separate parts of an object to avoid damage	6:19
6.12	The steps involved in wrapping, padding, and packing when shipping an object	6:20
6:13	Example of objects packed in a double box for shipping. The straps make it simple to remove the interior box	6:21
6:14	Example of written handling rules for NPS park collections	6:30
7.1	Levels of Containment in a Collection Storage System.....	7:29
7.2a	Example Assessment Worksheet	7:29
7.2b	Assessment Codes for Collection Storage Techniques	7:30
7.3	General Floor Plan of Proposed Museum Collection and Library Center at Grand Canyon National Park	7:32
7.4	Floor Plan of Proposed Museum Collection Space at Grand Canyon National Park	7:33
7.5	Floor Plan of Museum Collection Storage Room at Voyageurs National Park	7:34

Figure Number	<u>Caption</u>	<u>Page</u>
7.6	Cavity storage	7:35
7.7	Textile storage.....	7:35
7.8	Large Objects Housed on Steel Shelving	7:36
7.9	Map Cabinet	7:36
7.10	Racks for Large Objects.....	7:37
7.11	Painting Storage.....	7:37
8.1	Information Required in Conservation Treatment Documentation.....	8:10
8.2	Sample Narrative Examination Report	8:18
8.3	Sample Treatment Proposal	8:20
8.4	Sample Treatment Report	8:22
9.1	Security Bull's-eye	9:2
9.2	Threats to Museum Collections	9:6
9.3	Major Causes of Museum Fires	9:13
9.4	Types of Fire Detectors	9:17
9.5	Types of Intrusion Detection Devices	9:40
10.1a	Emergency Planning Master Worksheet	10:58
10.1b	Sample Completed Emergency Planning Master Worksheet	10:59
10.2	Risk Assessment Worksheet	10:61
10.3	First 48 Hours Emergency Response Checklist	10:72
11.1	Ventilation Chart	11:34
11.2	Sample Material Safety Data Sheet (MSDS).....	11:35
11.3	Material Safety Data Sheet for Formaldehyde Solution	11:37
11.4	The NFPA Hazard Symbol and Key to Color Code and Numbering System.....	11:45
12.1	NPS Acronyms Related to Funding, Programs, and Staffing.....	12:25
12.2	Sample PMIS Project Statement.	12:26
12.3	Sample OFS Project Statement.....	12:29
13.1	Curator and Other Park Staff Roles in Preserving Museum Collections	13:3
13.2	Sample MHP Title Page.....	13:16
13.3	Sample MHP Reference File Sheet: Environmental Concerns	13:17
13.4	Sample MHP Reference File Sheet: Equipment/Supplies Used to Control the Environment	13:18
13.5	Sample MHP Task Sheet: Dusting.....	13:19
13.6	Sample MHP Task Sheet: Pest Monitoring.....	13:20
13.7	Sample MHP Task Sheet: Review Housekeeping Plan	13:21
13.8	Sample MHP Task Sheet: Special Uses	13:22
13.9	Sample MHP Tracking Schedule: Daily	13:23
13.10.	Sample MHP Tracking Schedule: Weekly	13:24
13.11	Sample MHP Tracking Schedule: Quarterly	13:25
13.12	Sample MHP 5-Day Schedule	13:26

Figure Number	<u>Caption</u>	<u>Page</u>
A.1	Museum Properties Act of 1955 as Amended November 12, 1996	A:17
A.2	References to Museum Collections Management in Interior Property Management Regulations	A:18
A.3	Director's Order #24: NPS Museum Collections Management	A:19
E.1	Example Approved Scope of Collection Statement	E:3
E.2	Example Scope of Collection Summary	E:24
E.3	Checklist for Evaluating Scope of Collection Statements	E:25
F.1	Cost Estimates (2002)	F:7
F.2	NPS Checklist for Preservation and Protection of Museum Collections	F:11
G.1	Sample Scope of Work for a Security Survey	G:15
G.2	Sample Scope of Work for a Fire Protection Survey	G:20
G.3	Sample Furnished Historic Structure Opening and Closing Procedures	G:25
G.4	Sample Museum Collections Storage Opening and Closing Procedures	G:28
G.5	Sample Park Museum Collection Access Policy and Procedures	G:29
G.6	Sample Visitor Log	G:32
G.7	Conditions for Access to Museum Collections	G:33
G.7	Sample Memorandum of Understanding Between a Park and a Fire Company	G:34
I.1	Deterioration of Archeological Objects through Time	I:2
I.2	Vertical Stacking of Small Objects Within Standard Containers	I:7
I.3	Organization and Layering of Objects within a Storage Box	I:9
I.4	A Support Tray for Fragile Material	I:10
I.5	Customized Support Blocks for a Fragile Glass Bottle to be Fitted in a Museum Specimen Tray	I:10
I.6	Cavity Packing Technique for Small Objects	I:11
I.7	Construction of a Cradle Mount for Objects with Round Bases	I:12
I.8	Construction of a Portfolio Mount for Archeological Textile Fragments	I:14
I.9	Recommended Storage Materials	I:15
J.1	Suitable Temperature and Humidity Levels for Paper Storage	J:7
J.2	Suggested Maximum Levels of Major Gaseous Pollutants	J:9
J.3	Types of Enclosures	J:20
J.4	Types of Polyester Enclosures	J:20
J.5	Types of Boxes	J:21
J.6	Archival Separation Sheet	J:30
J.5	Example Handling Procedures	J:31
K.1	Upright Loom	K:6
K.2	Fan Folding a Textile	K:14
K.3	Rolling Textiles for Storage	K:17
K.4	Twill Tape Waist Supports	K:19
K.5	Muslin "Sling" Support	K:20
K.6	Padding the Folds of a Garment for Storage	K:21
K.7	Hat Supports	K:22
K.8	Bonnet on a Support	K:23
K.9	Internal Support for Gloves and Mittens	K:24
K.10	Support for a Fragile Fan	K:25
K.11	Padding an Umbrella for Storage	K:26

<u>Figure Number</u>	<u>Caption</u>	<u>Page</u>
K.12	Hook and Loop Tape Mount	K:30
K.13	Diagram of a Pressure Mount.....	K:32
K.14	Polyethylene Foam Torso	K:34
K.15	Proper Vacuuming Technique	K:36
K.16.	Interior of a Shipping Crate for Rolled Textiles	K:39
L.1	A Cross-section of a Painting	L:3
L.2	Proper Way to Carry a Small Painting.....	L:10
L.3	Paintings Stacked Against a Wall	L:12
M.1	National Fire Protection Agency Warning Sign for Cellulose Nitrate Film	M:21
N.1	The Three Principal Planes or Surfaces of a Typical Block of Wood: Tangential, Radial, and Cross Section	N:3
N.2	Graph illustrating the relationship between Relative Humidity and Equilibrium Moisture Content of Wood.....	N:4
N.3	Characteristic Shrinkage and Distortion of Wood.....	N:6
N.4	Typical Mortise and Tenon Joint	N:10
N.5	Typical Dovetail Joint.....	N:10
N.6	Common Veneer Applications	N:12
N.7	Proper Techniques for Moving Furniture	N:22
O.1	Identification of Metals	O:3
O.2	Identifying Active Corrosion.....	O:5
P.1	Method of Stabilizing Objects in Storage	P:16
P.2	Flush Mount for Hanging Heavy Mirrors	P:20
P.3	Technique for Wrapping a Fragile Object	P:23
P.4	Layered Foam Packing for Fragile Objects.....	P:24
R.1	Appropriate Light Levels for Photographic Media	R:7
R.2	Relative Humidity and Temperature Requirements for Photographic Media	R:16
R.3a-b	Condition Checklist for Visual Images (Sample).....	R:34
S.1	The Structure of Skin	S:2
S.2	Degrees and Types of Tannage	S:3
S.3	Characteristics of Leather and Skin Products	S:4
S.4	Thickness of Skins and Hides	S:5
S.5	Cleaning Techniques for Leather and Skin Objects in Good Condition	S:15
S.6	Constructing a Saddlemount	S:18
S.7	Leather and Skin Product Deterioration and Preventive Care	S:19
T.1	Use extra care when transporting specimens with delicate parts.....	T:9
T.2	Microscope slides stored horizontally in a slide cabinet	T:121
U.1.	Cabinet Storage of Paleontological Specimens	U:13
U.2.	Paleontological Specimen Cradled in Polyethylene Foam-lined Fiberglass Jacket	U:13
U.3.	Radioactive Specimen Cabinet with Venting System and Safety Signage	U:18
U.4.	Preparator Preparing a Specimen	U:23
U.5	Example Preparation Record #1.....	U:49
U.6.	Example Preparation Record #2.....	U:51

INTRODUCTION

The *Museum Handbook* covers a broad range of topics to guide National Park Service staff in managing museum and archival collections:

- Part I covers planning, preservation, and protection for the disciplines and materials represented in NPS collections, including professional ethics, specialized storage, environment standards, conservation treatments, and emergency preparedness.
- Part II outlines procedures for museum record keeping, including accessioning, cataloging, loans, deaccessioning, photography, and reporting annual collection management data.
- Part III provides guidance on access and use for interpretation, education, exhibition, and research. It covers legal issues, publications, two and three-dimensional reproductions, using museum objects in exhibits and furnished historic structures, and providing access for research.

NPS staff responsible for collections should make informed choices based on their own skills and experience, standards and procedures outlined in the *Museum Handbook*, advice provided by specialists, and additional information provided in the references found in the *Museum Handbook*. Staff should, as needed, seek advice or technical information from regional and support offices, the Harpers Ferry Center, and the Park Museum Management Program, National Center for Cultural Resources.

By following the practices represented in this guidance, trained staff can ensure that the National Park Service collections will be, as mandated by the 1916 NPS Organic Act, preserved and maintained for the use and enjoyment of the present and future generations.

Chapter 1: National Park Service Museums and Collections

	<u>Page</u>
A. Overview	1:1
What information will I find in this chapter?.....	1:1
Where can I find additional information on these topics?.....	1:1
B. Purpose of National Park Service Museums	1:1
What is a museum?	1:1
What is a museum object?	1:1
What do museums do?	1:2
What do I need to know about a museum’s primary responsibilities?	1:2
What is museum management?	1:2
What is museum collections management?.....	1:2
Under what authorities does NPS manage museums?	1:3
What distinguishes NPS museums?.....	1:3
How are NPS collections used?	1:4
C. History of National Park Service Museums	1:4
How did national park museums originate?.....	1:4
How quickly did NPS develop museums?.....	1:5
How did NPS museums grow in the 1920s?	1:5
How did the 1930s and the Great Depression impact NPS museums?	1:6
How did the NPS museum program fare in the 1940s and 1950s?.....	1:6
How did the Museum Act affect NPS museum operations?.....	1:7
What was the impact of Mission 66 on park museums?.....	1:7
What other initiatives and programs have influenced NPS museum operations in the decades since Mission 66?.....	1:7
D. Types of Collections	1:10
E. Archival Collections	1:10
What do NPS archival collections include?.....	1:10
What types of archival materials are in NPS collections?.....	1:10
F. Cultural Collections	1:12
What are archeological collections?.....	1:12
What methods does an archeologist use to recover and interpret archeological resources?.....	1:12
Does NPS keep all materials recovered from archeological investigations?	1:12
What types of archeological materials are in NPS collections?.....	1:13
What are ethnological collections?	1:13
What are some of the types of ethnological items that make up park collections?	1:14
Are there any special considerations when managing archeology and ethnology collections?	1:14
What are NPS history collections?.....	1:14
What types of objects make up NPS history collections?	1:15
G. Natural History Collections	1:16
Why does NPS collect and maintain natural history collections?	1:16
How does NPS authorize the collection of natural history specimens and determine their disposition?.....	1:17
What kinds of specimens are in NPS natural history collections?	1:17
Why are natural history collections important?.....	1:17
What characterizes NPS biological collections?.....	1:18

What are some examples of NPS biological collections?	1:19
What disciplines collect and study biological collections?.....	1:19
What characterizes NPS geological collections?.....	1:20
What are some examples of geological specimens in NPS collections?	1:21
What characterizes NPS paleontological collections?	1:21
What are some examples of paleontological specimens in NPS collections?	1:22
What specialties are represented in the discipline of paleontology?	1:22
How have park natural history collections developed over time?	1:23
What has driven recent growth of NPS natural history collections?	1:23
What determines how NPS natural history collections are used?	1:23
H. Introduction to NPS Museum Collections Management.....	1:24
What are the main elements of NPS Museum Collections Management?	1:24
What policy guidance is available on managing NPS museum collections?	1:24
What are the levels of responsibility for NPS collections management?	1:25
What are the museum management responsibilities of the Washington Office?	1:26
What are the museum management responsibilities of the Regional Offices?.....	1:27
What are the museum management responsibilities of the parks and centers?.....	1:27
What additional roles do the servicewide centers have?	1:29
I. Planning for Park Museum Collections	1:30
What general park plans are relevant to planning for park museum collections?	1:30
What does the Foundation Statement say about the museum collection?	1:30
How does the General Management Plan relate to the museum collection?.....	1:30
What program management plans are specific to the museum collections?	1:31
How does the park Strategic Plan address museum collections?	1:31
What is an implementation plan for museum collections?	1:31
What are Annual Performance Plans and Reports?	1:32
What are the requirements for museum-specific planning documents?	1:32
Are there any other park planning documents that may impact museum collections?.....	1:34
J. Ethics, Standards, and Professional Associations	1:35
What standards of ethical conduct apply to NPS museum professionals?.....	1:35
What other professional museum standards apply to NPS museums?.....	1:35
How can the park and I benefit from what professional associations offer?	1:36
K. Selected Bibliography.....	1:39

CHAPTER 1: NATIONAL PARK SERVICE MUSEUMS AND COLLECTIONS

A. Overview

1. *What information will I find in this chapter?*

This chapter will introduce you to the National Park Service (NPS) museum program. It includes information on:

- The purpose of NPS museums
- The history of NPS museums
- The kinds of NPS museum collections
- Introduction to NPS museum collections management
- Organizational structure for the servicewide museum program
- Planning for park museum collections
- Ethics, standards, and professional organizations

2. *Where can I find additional information on these topics?*

Consult the references in sections G and H for a listing of associations, Web sites, books, and journals with useful information.

B. Purpose of National Park Service Museums

1. *What is a museum?*

In 1895, George Browne Goode, Director of the Smithsonian Institution's United States National Museum, defined a museum as "...an institution for the preservation of those objects which best illustrate the phenomena of nature and the works of Man, and the utilization of these for the increase in knowledge of the people," (Goode, 1895). The United States Congress, in the Museum and Library Services Act (Title II of P.L. 94-462), defined a museum as "...a public or private nonprofit agency or institution organized on a permanent basis for essentially educational or aesthetic purposes, that utilizes a professional staff, owns or utilizes tangible objects, cares for the tangible objects, and exhibits the tangible objects to the public on a regular basis." Both definitions have important qualifiers that distinguish museums from exhibit galleries, curio collections, and other types of property that an institution may manage. Professional museum associations offer additional variations on these basic definitions.

2. *What is a museum object?*

A museum object is a material thing possessing functional, aesthetic, cultural, symbolic, and/or scientific value, usually movable by nature or design. Museum objects include prehistoric and historic objects, artifacts, works of art, archival material, and natural history specimens that are part of a museum collection. (Large or immovable properties, such as

monumental statuary, trains, nautical vessels, cairns, and rock paintings, are defined as structures or features of sites.) (See NPS *Cultural Resource Management Guideline*, Appendix A, Glossary.)

3. *What do museums do?*

Museums collect, preserve, study and interpret, and provide appropriate public access to natural and cultural materials that have been assembled according to a plan.

The collection must have a written scope statement (see *Museum Handbook*, Part I, Chapter 2, Scope of Collections). The items in the collection, whether cultural or natural, and their associated documentation are valuable for the information that they convey about people, processes, events, and interrelationships within cultural and natural systems. Placing objects within a broader context, through research, analysis and documentary records, provides the greatest public enjoyment and benefit.

4. *What do I need to know about a museum's primary responsibilities?*

With few exceptions, after their founding, museums continue to collect within their stated scope. All activities in the museum revolve around the collection. **Collecting, and documenting the resulting collection, is the first responsibility.**

Because the collection is a non-renewable resource, the museum must ensure its preservation. Museum objects and specimens lose their value if they, or their associated data, are damaged or lost. **Preserving the collection is the second responsibility.**

In order to ensure public benefit from the collections, the museum must provide for access, use, and interpretation, including research and exhibit. Research, by the museum staff and others, is the foundation for public exhibit and museum education programs. Research and the resulting interpretation to the public, either through exhibits or public programs, demonstrate the collection's value to the public. **Providing for collection access, use, and interpretation is the third responsibility.**

Museum Handbook, Part I, provides information on collecting, preservation, and protection. *Museum Handbook*, Part II, has procedures for documenting collections. *Museum Handbook*, Part III, addresses collections access and use.

5. *What is museum management?*

Museum management consists of the policy, procedures, processes, and activities that are essential to fulfilling functions that are specific to museums, such as acquiring, documenting, and preserving collections in appropriate facilities and providing for access to and use of the collections for such purposes as research, exhibition and education. The production of exhibits, the presentation of interpretive and education programs, and the publication of catalogs, books, and Web sites featuring museum collections and themes are part of museum management. The administrative functions relating to funding, human resources, maintenance, and property management are also part of museum management and require certain knowledge and skills specific to the museum environment.

6. *What is museum*

Museum collections management is one aspect of museum management. It

collections management?

is a process, not a product. It is a systematic approach to the proper preservation and the wise use of museum objects. It includes any activity associated with the acquisition, accountability, documentation, conservation, protection, disposition, and use of museum objects. It involves assessing and planning for the short-term and long-term needs of a collection as well as carrying out the day-to-day activities of caring for objects on exhibit and in storage. The goal of collections management is to make museum collections available to the user for exhibit and study while preserving them for future generations.

7. *Under what authorities does NPS manage museums?*

Five laws provide the basic legal mandate for the NPS to manage museums. The laws are:

Antiquities Act of 1906

16 USC 431– 433; June 8, 1906, ch. 3060, 34 Stat. 225

National Park Service Organic Act

16 USC 1– 4; Aug. 25, 1916, ch. 408, 39 Stat. 535

Historic Sites, Buildings, Objects, and Antiquities Act (commonly known as the Historic Sites Act of 1935)

16 USC 461– 467; Aug. 21, 1935, ch. 593, 49 Stat. 666

Management of Museum Properties Act (commonly known as the Museum Act)

16 USC 18f– 18f- 3; July 1, 1955, ch. 259, 69 Stat. 242, PL 104- 333

Archaeological Resources Protection Act of 1979 (ARPA)

16 USC 470aa– 470mm; PL 96- 95

See Appendix A for a description of these and other relevant laws.

8. *What distinguishes NPS museums?*

NPS museums collect objects specific to the mission of the individual parks and interpret those collections in their original context. The collections are site-specific, that is, they pertain to that particular NPS site. With the exception of house museums, most other museums gather thematic collections from many different sites and house them in one place. By contrast, NPS museums collect and interpret many objects and specimens at the site of origin. For example, the furnishings and personal belongings at Harry S Truman National Historic Site are preserved and exhibited in the Truman Home as they were when the family occupied the house. The vast majority of holdings in NPS museums are derived either from within the park boundaries or from areas intimately associated with the parks.

Another distinguishing characteristic of NPS museums is that they are part of a larger NPS museum system. While park museums are site-specific, each is part of a greater system that sets policies and standards and guides their operation. No other museum network is so varied and dispersed, yet so administratively bound as a unit. The NPS museum system provides broad representation of the natural and cultural heritage of the United States. The scope of the system is wider than that of most public or private institutions. The NPS museum system is the largest such system in the

world.

Although NPS museums may store their collections at another location, such as a NPS archeological center or a non-Federal museum, the park site retains ultimate responsibility for the collections.

National Park Service museums (and their collections):

- directly support the park mission
- aid understanding among park visitors
- advance knowledge in the humanities and sciences
- provide baseline data for NPS managers, scientists, and other researchers
- preserve scientific and historical documentation of the park's resources and purpose

Park collections range in size from fewer than 100 to over 6 million items.

9. *How are NPS collections used?*

National Park Service museum collections are used in a variety of ways. In keeping with the Service's public trust responsibilities, most uses of collections are educational. The dominant uses are:

- **Research** conducted by NPS and non-NPS scientists, historians, archeologists, ethnographers and other specialists.
- **Publications** that the park or others produce. Each year, photographs and/or descriptions of NPS museum objects appear in numerous articles, books, and other publications.
- **Exhibits** in NPS museums and visitor centers, as well as loans to non-NPS museums for special exhibitions.
- **Educational programs** at the park, schools, or other public venues.
- **Media products**, such as documentaries (motion picture, television, and radio), Web sites, "Web casts," and virtually any other new media format.

As society develops new media technologies, the opportunities to provide access to collections expand. Park visitors can view objects, specimens and archives in the museum or furnished historic structure at the site and gain the special understanding that comes with seeing the items "in context." New technologies, however, can reach previously underserved populations. For example, data and images in the NPS Web Catalog (<http://www.museum.nps.gov>) and Web exhibits featuring museum collections (<http://www.cr.nps.gov/museum>) are available worldwide in homes, schools, offices, and libraries. By effectively using these technologies NPS can greatly expand the audience served and the public benefit.

However you use the park's collection, remember that accurate interpretation and preservation of each object and the collection as a whole are primary considerations.

C. History of National Park Service Museums

1. *How did national park museums originate?*

For over a century, museums have been an integral part of America's national parks. From modest beginnings in 1904 to today's state-of-the-art park museums and visitor centers, visitors have encountered engaging museums in units of the National Park Service.

NPS museum operations chief Ralph Lewis observed that National Park Service "...museums did not grow from a single root, nor did any central authority decree their initial establishment. The first ones developed independently, created by local initiative to meet perceived needs," (1993). NPS Chief Curator Ann Hitchcock explained, "Initially, [museums in parks]...were rudimentary—a 1904 arboretum in Yosemite, a table of artifacts in the ruins at Casa Grande...even a museum in a tent at Sequoia. This strong association with place is a characteristic that continues to distinguish park museums and collections," (2004).

2. *How quickly did NPS develop museums?*

The National Park Service established new museums quite rapidly—Stephen T. Mather, the first NPS director, was an enthusiastic supporter who understood the importance of museums in the parks. In his 1920 annual report, he noted, "One of the most important matters to receive earnest consideration is the early establishment of adequate museums in every one of our parks."

Director Mather initiated numerous campaigns to encourage additional support for the parks, with the public and with government and business interests. These activities included special exhibitions of national park-themed art. Mather arranged an exhibition of paintings of national park scenes in January 1917 in conjunction with the Fourth National Park Conference. The Smithsonian Institution exhibited the works by Albert Bierstadt, Thomas Moran, Carl Rungius, and other noted artists for some time following the conference. The Director also developed a "...traveling exhibition intended for display in libraries [of]...24 framed photographs of park scenery packed in two reusable shipping boxes." The exhibition was so popular that Mather "...request[ed] funds to produce and circulate additional sets," (Lewis 1993).

A little more than a year later, Secretary of the Interior Franklin K. Lane established guidelines for the new National Park Service. The guidance included the statement that "Museums containing specimens of wild flowers, shrubs, and trees, and mounted animals, birds, and fish native to the parks, and other exhibits of this character will be established as authorized." Support for NPS museums was strong and that support was at the highest levels in Washington. At the same time, increased public and philanthropic interest in NPS museums provided additional opportunities for growth.

3. *How did NPS museums grow in the 1920s?*

In the early 1920s, Chauncey Hamlin of Buffalo, New York, (who had helped to endow the Buffalo Museum of Science) became a supporter of the national parks. As Hamlin's interest grew, he also supported the establishment of new museums in the parks. Following his election as president of the American Association of Museums (AAM) in 1923, Hamlin was able to procure funding from the Laura Spelman Rockefeller Memorial to help underwrite a new museum at Yosemite. By 1926, the new Yosemite Museum opened to the public (Lewis 1993).

Yellowstone opened its first museum in 1922. Over the following eight years, the park developed branch museums at Old Faithful, Madison Junction, and Norris Geyser Basin, all with the assistance of AAM. Meanwhile, the AAM, the Laura Spelman Rockefeller Memorial, and John C. Merriam of the Carnegie Institution supported the development of the Yavapai Point Museum at Grand Canyon National Park. Merriam, who actually oversaw the work "...created a museum where the canyon was the exhibit and the museum housed viewing instruments, labels, and guided interpretation. The model was so successful that a generation later it was deemed a classic example of interpretive planning in parks," (Hitchcock 2004).

Yellowstone naturalist Carl P. Russell was promoted to the new position of field naturalist-museum advisor in 1929. Russell relocated to California, and reported to Chief Naturalist Ansel Hall at the NPS Field Division of Education, located at the University of California, Berkeley.

4. *How did the 1930s and the Great Depression impact NPS museums?*

The 1930s brought tremendous change to the NPS. Shortly after taking office in 1933, President Franklin Roosevelt transferred the various historical areas managed by the War Department (primarily American Revolution and Civil War battlefields) to the National Park Service. Other parks, monuments, and memorials were transferred to the NPS as well—national monuments managed by the Forest Service and the National Capital Parks in Washington, DC. Many of these areas already managed museum collections, which also transferred to NPS stewardship.

NPS museums, like many other Federal projects in the 1930s, received increased support resulting from the economic recovery efforts of President Roosevelt's New Deal. One such windfall occurred in 1935, when \$65,000 in Public Works Administration (PWA) funds became available to support new museums in the parks. In January of that year, Carl P. Russell was detailed from Berkeley to Washington to establish a new Eastern Museum Division. He also recruited a temporary staff of curators, artists, and craftsmen.

At the same time, funding and labor provided by the Civilian Conservation Corps (CCC) and Works Progress Administration (WPA) allowed for the construction of several new park museums. In workshops at Berkeley, California, and Fort Hunt, Virginia, "CCC boys" fabricated exhibits and park topographical map models (some of which are still in use at NPS visitor centers). The National Park Service's first curators (in title) were funded by the PWA. Curators, assistant curators, and museum assistants developed museum planning documents; planned, supervised, and

constructed exhibits; and helped Russell carry out the multitude of tasks connected with the newly enlarged NPS museum program.

In 1935, Congress passed the Historic Sites, Buildings, Objects, and Antiquities Act. The new law declared that "...it is a national policy to preserve for public use historic sites, buildings, and objects of national significance for the inspiration and benefit of the people of the United States." This legislation empowered the Secretary of the Interior (working through the NPS) to preserve and maintain objects of national historical or archeological significance and to "establish and maintain museums in connection therewith."

5. *How did the NPS museum program fare in the 1940s and 1950s?*

The 1940s began with the NPS placing even greater emphasis on the development of museum standards. With strong support from Carl Russell, Ned Burns (who followed Russell as chief of the NPS museum division) prepared the National Park Service *Field Manual for Museums* in 1941. Intended as a guide to park museum development and operation, the field manual was available to other museums, institutions, and the general public through the Government Printing Office. Non-NPS museums as well as park museums used the publication.

World War II caused a virtual halt in park museum growth, as NPS budgets and personnel were transferred to the war effort. After the war, however, the museum program once again began to grow. The museum laboratory in Washington, DC, reopened in 1946. Four years later, NPS appointed its first conservator, Elizabeth Jones, a paintings conservator from the Fogg Art Museum at Harvard University. Jones quickly developed a new conservation laboratory and the first NPS conservation treatment program. Then, in 1954, following Ned Burns's death, Ralph Lewis became the Chief of the Branch of Museums. In 1956, NPS launched Mission 66, a ten-year program that planned to install ten new exhibits each year.

The decade of the 1950s also saw two other important events: Congress passed the Museum Act in 1955, and two years later, the Service issued the *Museum Records Handbook* (today's *Museum Handbook*, Part II: Museum Records). (The *Museum Handbook*, Part I: Museum Collections, would debut in 1967.)

6. *How did the Museum Act affect NPS museum operations?*

During the early 1950s, the Service recognized the need for additional legislative guidance concerning its legal authority to acquire, preserve, and dispose of museum objects. In a number of past situations, the Service's authority to carry out some common museum practices was lacking or unclear. Congress passed the Museum Act to provide clear guidance to the Service in these matters. The law authorized the Secretary of the Interior through the National Park Service to acquire museum collections through donation and purchase and to loan and exchange collections "...in such manner as he shall consider to be in the public interest."

7. *What was the impact of Mission 66 on park museums?*

In 1956, in response to a growing number of park visitors, NPS launched a ten-year program, dubbed Mission 66, to build museums. Not since the New Deal of the 1930s did the parks experience such growth, renewal, refurbishment, new facilities, and corresponding staff to carry out the

work. The Service constructed nearly 100 new visitor centers and museums during Mission 66. Mission 66 funded new visitor centers at Zion National Park, Dinosaur National Monument (Quarry Visitor Center), Everglades National Park (Flamingo Visitor Center), Booker T. Washington National Monument, Great Smoky Mountains National Park (Sugarlands Visitor Center), and the Museum of Westward Expansion beneath the Gateway Arch at Jefferson National Expansion Memorial in St. Louis. Although many parks have outgrown and replaced (or added to) their Mission 66 facilities, many others continue in use to this day. Mission 66 provided the parks with critical, needed improvements.

8. *What other initiatives and programs have influenced NPS museum operations in the decades since Mission 66?*

The 1970s

In the 1970s, NPS museum programs continued to grow. In 1974, the Branch of Museum Operations became the Division of Museum Services. The following year, NPS staff conducted the first Collection Management Plan, at Hubbell Trading Post National Historic Site. In 1976, the Service published the *Manual for Museums*, a bound version of the looseleaf *Museum Handbook*, which was available to the larger museum community (and the general public) through the Government Printing Office. Also, in the 1970s, the *Conserve O Gram* series of museum preservation technical leaflets debuted.

On the legislative front, Congress passed two new laws pertaining to archeological resources on Federal lands, the Archaeological and Historic Preservation Act of 1974, and the Archaeological Resources Protection Act of 1979 (ARPA). Both acts mention museum collections resulting from archeological activities. (See Appendix A.)

Understandably, following the enactment of ARPA, NPS collections grew in both size and scope.

The 1980s and Beyond

NPS museum programs continued to expand in the 1980s, 1990s, and into the new millennium. In 1980, the Director appointed a Chief Curator, Ann Hitchcock. Three years later, key Washington and field curatorial staff met to develop a servicewide museum management strategy that stressed:

- Establishing minimum preservation standards
- Accountability of museum property
- Strengthening training and development opportunities for staff
- Incorporating curatorial review in the planning process
- Improving collections management policy guidance to the field

Over the next quarter century, these five goals have been the driving force behind the Service's museum programs. Minimum preservation and protection standards were established with Special Directive 80-1, its subsequent revision, and eventual replacement by the NPS Checklist for

the Preservation and Protection of Museum Collections (Museum Checklist).

In the annual Collections Management Report (CMR), initiated in 1983, parks provided information on the number of items acquired, deaccessioned, cataloged, loaned and used in exhibits. Accountability was strengthened when, in 1984, and again in 2000, the *Museum Handbook*, Part II, was revised to reflect the latest, accepted museum practices for collections documentation. In 1985, a servicewide call was issued for every park to have an approved Scope of Collection Statement. Two years later, the NPS issued the Automated National Cataloging System (ANCS) to further the parks' accountability efforts. This program, augmented, improved, and modernized with a Windows platform in 1998, became ANCS+. No longer limited to accessioning and cataloging, the system covers documentation for all aspects of collections management, including loans, deaccessioning, housekeeping, Museum Checklist standards, annual inventories, and annual reporting.

In addition to the reissued Part II of the *Museum Handbook*, Part I: "Museum Collections," was reissued in 1990, with more revisions and additions issued nearly every year since 1999. *Museum Handbook*, Part III: "Museum Collections Use," was issued in 1998. The three-part *Museum Handbook* provides NPS staff not only with critical guidance concerning documentation, preservation, and access to and use of collections, but also with important collections management policy guidance to the field. The other preservation publication, the *Conserve O Gram* series, which was first issued in 1975, was revised and reissued in 1993, with additional leaflets added to the series annually.

The Native American Graves Protection and Repatriation Act of 1990 (NAGPRA) (25 USC 3001-3013) has had a profound impact on NPS museum collections. The law and associated regulations address the rights of lineal descendants, Indian tribes, and Native Hawaiian organizations to Native American human remains, funerary objects, sacred objects, and objects of cultural patrimony. They require Federal agencies and institutions that receive Federal funds to provide information about Native American human remains, funerary objects, sacred objects, and objects of cultural patrimony to lineal descendants, Indian tribes, and Native Hawaiian organizations and, upon presentation of a valid request, return these cultural items to them. NPS has repatriated items subject to NAGPRA and has consulted with traditionally associated groups when managing museum collections.

Implementation of the Government Performance and Results Act of 1993 (GPRA) presented new challenges to NPS museum programs. Performance management has increased annual reporting responsibilities for field, regional, and WASO staff. Yet, at the same time, programming, prioritization of work, and accountability were strengthened. The museum program applied the existing CMR and Museum Checklist data to meet the performance reporting requirements of GPRA. The ANCS+ collections management software program includes the Museum Checklist and CMR, which enable park staff to quickly produce annual museum reporting data.

The advent of the Web provided new ways to make park collections

accessible to the public through Web exhibits and the Web Catalog. In 2004, NPS initiated the Teaching with Museum Collections program, which introduced object-based lesson plans for teachers to use Web-accessible NPS museum collections resources in the classroom. See <http://www.cr.nps.gov/museum/>.

Communication across division, park, regional, and servicewide lines is vital to the success of park museum programs. Facility management, resource management, interpretation and education, administration, and resource and visitor protection—virtually every park function is in some way supportive of, a user of, or a collector or creator of museum collections. The superintendent delegates responsibility for the park collection to the park curator or collateral-duty curator, but many offices collaborate to provide effective collections management.

In 2004, the Service observed the NPS Museum Centennial—the first century of museums in the parks. This history began with several small, independently established park museums created on shoestring budgets, without the assistance of professional curators. Early on, these programs received additional attention, funding, and professional assistance. Although not every park has a curator on site, each park has a curatorial contact and a qualified curator must have oversight for each park’s museum operations.

From these humble beginnings over a century ago, the NPS museum system has become the world's largest. As of 2005, more than 350 park units preserve over 115 million museum objects, specimens and archival items to tell the stories of the places where many of the most exciting events of American history, cultural experiences, and natural phenomena have taken place.

D. Types of Collections

The National Park Service is one of the primary Federal entities that preserves cultural and natural resources. NPS museum collections include diverse disciplines and represent a significant portion of the resources that the Service is charged to preserve and protect. The collections are characterized as cultural, natural, and archival. The documentation system further classifies the items. The broad categories are divided into general disciplines as follows:

- Archival Collections
 - Personal papers and manuscripts
 - Resource management records
- Cultural Collections
 - Archeology
 - Ethnology
 - History
- Natural History Collections (also called natural resource collections)
 - Biology
 - Geology
 - Paleontology

E. Archival Collections

1. *What do NPS archival collections include?*

Archival holdings are the largest component of servicewide collections by item count. At the park-level, archives form a key part of the park's resources. In many cases, archives are original to the site and date to the historic period. For example, archives at Edison National Historic Site greatly expand our understanding of Thomas Edison's business as well as his private life.

Park archival collections contain information essential for understanding the park's past, natural and cultural interrelationships, events, and changes over time, as well as the human impact (including NPS management) on the park. Personal papers illuminate our understanding of the individuals whose lives are documented and interpreted at park sites. Resource management records that park staff and researchers create become part of the archival collections. Resource management records address:

- Management of cultural and natural resources over time
- Scientific research

2. *What types of archival materials are in NPS collections?*

NPS archival collections include:

- Personal papers, organizational archives, and assembled manuscript collections that NPS receives from non-Federal sources.
- Copies of records (formerly sub-official records). Occasionally, selected copies of Federal records may be kept for purposes of reference or convenience. For example, selected copies of superintendent correspondence that is particularly relevant to a resource management issue may be kept.
- Resource Management Records. Records associated with resource management typically include field notes and catalogs, daily journals, drawings and maps, photographs and negatives, slides, sound recordings, raw data sheets, instrument charts, remote sensing materials, collection inventories, analytical study data, computer documentation and data, as well as reports and any other documents generated through the resource management activity. Oral histories created by NPS employees are a special type of resource management record. Although these records are created by a Federal employee, contractor, or partner, the Service retains and manages them in the museum collection because ready access is critical to the ongoing interpretation, management, and preservation of other park natural and cultural resources. Resource management records are identified on the NPS records schedule for retention and management in the museum collection.

Other than resource management records, Federal records should not be included in the museum collection without specific authorization from the National Archives and Records Administration (NARA). These records are the original or "record copy" documents created or received in the course of performing the daily work of the NPS. Examples of records that do not belong in the museum collection include audit records, budget materials, central files, contracting files, financial records, law enforcement records, legal records, museum and project administrative records, permits, personnel records, and superintendent's correspondence files. By law, NARA

See *Museum Handbook*, Part II, Appendix D: Museum Archives and Manuscript Collections, for additional information concerning NPS archival collections.

Examples of archival collections include:

- The Edison Archives, Edison National Historic Site
- John R. Fordyce Archival Collection, 1897-1912, documenting Fordyce's engineering activities and the dealings of the Thomas-Fordyce Manufacturing Company, as well as personal correspondence, Hot Springs National Park
- Archeology Project Records, Mesa Verde National Park
- Albright Manuscript Collection, papers of Horace Albright pertaining to conflict over Mineral King, Sequoia and Kings Canyon National Parks
- Shenandoah National Park Resource Management Records, 1880-1996, Shenandoah National Park

F. Cultural Collections

Cultural collections are human-made objects or natural history specimens collected because of their human cultural context.

1. *What are archeological collections?*

Archeological collections are material remains that are recovered using archeological methods. Associated records (resource management records), such as maps, logs, research notes, laboratory analyses, and photographs, are classified as archival collections, although they remain connected to their related archeological collections. (See section E.2.) Archeological collections may represent any period in human history as long as the material was recovered by archeological methods. These collections help us to understand past cultures and their natural world. By preserving and studying these collections, we gain insight into the lives and worlds of those individuals and groups who previously inhabited park areas.

Archeological collections are created through authorized NPS undertakings, including Archaeological Resources Protection Act (ARPA) violation cases. NPS archeological collections include materials generated by researchers working under Antiquities Act or ARPA permits and by professional or avocational archeologists using a valid scientific

methodology before the establishment of the park. Both surveys and excavations can generate archeological materials and associated records.

2. *What methods does an archeologist use to recover and interpret archeological resources?*

Archeological methods recover materials from the ground surface or subsurface using systematic procedures and documentation. Whenever an archeologist investigates a site and removes materials, the site is altered, perhaps even destroyed. At the very least, the original context, “the way artifacts and other material lay in relation to one another” is destroyed. Archeological procedures ensure thoroughness and regularity in data recovery. One goal is to have a systematic collection—a unified collection of objects and associated records and data (resource management records). These data play a key role in the ongoing management of the excavated site and other archeological resources.

Once the site is altered and objects are removed, the records that document the archeological investigation become the basis for understanding the site and the meaning of the objects in context. These documented collections are available for research and exhibit. For new research projects, the NPS encourages use of these well-documented systematic collections rather than excavation in order to preserve and protect remaining archeological sites, which are non-renewable resources.

3. *Does NPS keep all materials recovered from archeological investigations?*

Most, but not all. Archeological materials excavated or removed from NPS lands remain the property of the United States (see 43 CFR 7.13) except human remains, associated funerary objects, and cultural patrimony subject to NAGPRA, which specifies conditions for their recovery and disposition to lineal descendants, Indian tribes, or Native Hawaiian organizations (see 43 CFR 10). With the exception of the items subject to NAGPRA, artifacts and specimens recovered from archeological resources, along with associated records and reports, are maintained together in the park museum collection (Management Policies, 5.3.5.1). Human remains, associated funerary objects, and cultural patrimony subject to NAGPRA, but in park collections prior to passage of the Act in 1990, were included in summaries and inventories and are available for deaccessioning and repatriation in accordance with 43 CFR 10. Other archeological collections may be deaccessioned under limited conditions, such as approved destructive analysis; when the park lands from which the items come are deauthorized; or when the materials are hazardous (see *Museum Handbook*, Part II, Chapter 6, Deaccessioning).

Human remains, associated funerary objects and cultural patrimony subject to NAGPRA and discovered inadvertently or intentionally excavated after the passage of the Act are held in suitable conditions until appropriate and legal disposition occurs. They are not accessioned into the museum collection, but the park must ensure inventory control. Any resource management records concerning such remains and objects become part of the museum collection.

4. *What types of archeological materials are in NPS collections?*

Archeological material remains are artifacts, cultural objects manufactured by humans in the past, intact or fragmentary natural objects, by-products, organic materials, paleontological specimens found in physical relationship with prehistoric or historic resources, specimens (or *ecofacts*) associated with cultural activity (such as shells, seeds, floral remains, and soil

samples), and environmental and chronometric specimens.

Examples of archeological collections include:

- Adze, Bering Land Bridge National Preserve
- Arrow Shaft Smoother (750-1150 AD) and a Puerco Black-on-White Bowl (1030-1200 AD), Chaco Culture National Historical Park
- Copper falcon effigy (1-350 AD), Hopewell Culture National Historical Park
- Civil War minié balls, Stones River National Battlefield
- Soil sample, Conways Brigade, Valley Forge National Historical Park
- Sherd, slip-decorated red earthenware, Narbonne House, Salem Maritime National Historic Site

5. *What are ethnological collections?*

Ethnology is the comparative and analytic study of cultures. Ethnography is the scientific description of individual societies and cultures.

Ethnological collections may be from any contemporary culture or from the historical and traditional culture from which the contemporary culture and people are descended. Ethnological collections are usually comprised of objects from many different cultures. Generally, but not always, NPS ethnological collections are from cultures considered indigenous to the park, to the surrounding geographic area, or to a large geographic area addressed in the park's mission. In addition, most NPS ethnological collections are Native American, Alaska Native, Native Hawaiian or Polynesian.

Most ethnological objects in NPS collections are traditionally manufactured. They range from utilitarian objects to works of art. Raw materials collected for use in the production of ethnological objects, such as pigments, fibers, and foodstuffs are classified as ethnological although they might otherwise be considered natural history collections.

When ethnographers and others make collections they usually will have associated records, such as field notes and photographs. These associated records go into the park's archival collection.

6. *What are some of the types of ethnological items that make up park collections?*

Examples of NPS ethnological collections:

- Yokut baskets at Sequoia and Kings Canyon National Parks
- Oglala headdresses at Badlands National Park
- Teak box with inlaid abalone shell decoration, Samoan, at San Francisco Maritime National Historical Park
- Navajo blankets and rugs at Hubbell Trading Post National Historic Site

7. *Are there any special considerations when managing archeology and ethnology collections?*

Yes. Be sure to engage in proper consultations with traditionally associated peoples well before you begin any new initiatives regarding archeology and ethnology collections. Some examples of initiatives include exhibits, relocation of collections, and changes to collections-use policies. Native peoples who are culturally affiliated with a park's ethnological collections may want to consult regarding the preservation, care and use of these collections. NPS policy mandates that the Service consult with traditionally associated peoples when developing such policies and initiatives.

In addition, NAGPRA requires that NPS provide information about Native American human remains, funerary objects, sacred objects, and objects of cultural patrimony to lineal descendants and culturally affiliated Indian tribes and Native Hawaiian organizations and, upon presentation of a valid request, return these cultural items to them. NPS has repatriated items subject to NAGPRA and, since passage of the Act in 1990, has carried out consultations with traditionally associated groups when managing museum collections. (See *Cultural Resource Management Guideline*, Appendix R, Guidance for National Park Service Compliance with NAGPRA, and *Museum Handbook*, Part II, Chapter 6, Deaccessioning.)

In accordance with NPS *Management Policies* (2006), Chapters 5 and 7, the Service will not exhibit Native American, Alaska Native, and Native Hawaiian human remains or photographs of those remains. Drawings, renderings, or casts of such remains will not be displayed without the consent of culturally affiliated Indian tribes and Native Hawaiian organizations. Parks must consult with culturally affiliated or traditionally associated peoples to determine the cultural significance and the culturally appropriate treatment of any object whose cultural importance is suspected but not confirmed, such as a sacred object. These consultations must occur before such an object is exhibited and before any action that might affect the resource.

8. *What are NPS history collections?*

NPS history collections reflect the entire spectrum of materials made and used during recorded times by humans residing in what today is the United States. They include cultural collections that are neither archeological nor ethnological. These collections may document individual or community life and social, cultural, political, economic, and technological trends and events. They also include art, such as paintings and sculpture. As a whole, the diverse assemblages of NPS history collections document continuity and change over time in the nation.

Some history collections reflect elite lives and activities of well-known individuals; others evidence everyday lives and actions of working men and women. The owners of some objects were Presidents; the owners of others are unknown. The significance and value of both is that they document American social, cultural, political and economic histories. Documenting and interpreting those objects to the public in the context of their original settings enhances the public's understanding.

To fill minor interpretive gaps, especially in exhibits and furnished historic structures, parks may acquire items that are of the same period and are documented to be similar to items originally at the site. Parks may

also add reproductions to the collections to fill gaps or to substitute on exhibit for a fragile original. Both period pieces and reproductions must be clearly documented so that they are not confused with objects original to the site.

9. *What types of objects make up NPS history collections?*

History collections range from high style furnishings at Hampton National Historic Site, to simple furnishings and books at Carl Sandburg Home National Historic Site, to tools of the 19th century textile industry at Lowell National Historical Park. They include inventions at Thomas Edison National Historic Site and medals and sculptures at an artist's home (Saint-Gaudens National Historic Site). Civil War military armaments and artifacts at Gettysburg National Military Park and collections as diverse as architectural fragments and portraits by the famous Peale family at Independence National Historic Site are in NPS history collections.

Additional examples include:

- Personal Items:
 - Frederick Douglass's top hat, Frederick Douglass National Historic Site
 - George Washington's dress sword, which he wore during his Inauguration, April 30, 1789, from Morristown National Historic Park
 - Ranch hand Jack Peters's cowboy boots (circa 1930), Grant-Kohrs Ranch National Historic Site
 - Joseph Hopkins's carpentry and blacksmithing tools, used by Hopkins to help construct the fort at Pipe Spring, 1870, Pipe Spring National Monument
- Historic Furnishings:
 - Mahogany furniture, antebellum era, from the collection of William Johnson, a free African-American, from Natchez National Historical Park
 - "Fruit case furniture" made from left-over and recycled wood, by Japanese Americans imprisoned in World War II internment camps, at Manzanar National Historic Site
 - The Lincoln Family's mahogany and horsehair upholstered sofa, Lincoln Home National Historic Site
- Religious artifacts:
 - The nineteenth century "Icon of St. Innocent of Irkutsk," in the Russian Bishop's House, Sitka National Historical Park
 - Eleanor Roosevelt's *Book of Common Prayer*, Eleanor Roosevelt

National Historic Site

- Vehicles:
 - Truck, “The Booker T. Washington Agricultural School on Wheels,” manufactured by the White Motor Company in 1930, at Tuskegee Institute National Historic Site
 - President Harry S Truman’s automobile, a 1972 Chrysler Newport Royal, still parked in the garage of the Truman Home at Harry S Truman National Historic Site
- Artwork
 - “Cathedral Rock, Yosemite,” Albert Bierstadt, 1870, oil on canvas, Marsh-Billings-Rockefeller National Historical Park
 - “Yellowstone Canyon, 1871,” Thomas Moran, watercolor, Yellowstone National Park

G. Natural History Collections

NPS natural history collections are diverse, including plant, animal, geological, and paleontological specimens associated with the lands that today are under NPS stewardship. NPS natural history collections are primarily specimens collected from within park boundaries. Because ecosystems, both living and fossil, and geological features extend beyond park boundaries, some specimens may originate outside park boundaries and be acquired by means other than field collection.

1. *Why does NPS collect and maintain natural history collections?*

The National Park Service maintains natural history collections primarily to voucher, or document, the presence of plants, animals, fossils, rocks and minerals in the park at a particular place and time. Researchers and resource managers use this information for science and resource management decisions. In addition, the results of the research and the specimens may be used in exhibits and as the basis for education and interpretive programs in parks. Natural history collections and their associated records, which are managed as archival collections, document the park’s natural environment—its geological history, current conditions, and changes over time. For example, the collections can be the basis for resource management decisions, such as eradication of an exotic or restoration of native species; or provide evidence of environmental change, such as in water or air quality; or document the occurrence of environmental toxins such as DDT or mercury.

For more information on collecting and natural resource management, see *Management Policies*, Chapter 4, Natural Resource Management, and *Reference Manual 77, Natural Resource Management*.

2. *How does NPS authorize the collection of natural history specimens and determine their*

Parks encourage and permit scientists to conduct research, including collecting specimens, to further the park mission of encouraging science and provide the scientific basis for resource management decisions. Specimen collection is governed by 36 CFR 2.5 (see *Museum Handbook*,

disposition?

Part II, Chapter 4, section VI) and the Research Permit and Reporting System (see <http://science.nature.nps.gov/research/ac/ResearchIndex>). Specimens collected on park lands and not consumed in analysis or otherwise destroyed are permanently retained, remain federal property, and become part of the park museum collection, as stated in the servicewide General Conditions for Scientific Research and Collecting Permit (General Conditions).

Superintendents may authorize park employees and non-NPS researchers to collect specimens in parks. Non-NPS researchers must have a permit. Both NPS and non-NPS researchers must comply with the General Conditions. Park curators are part of the permitting process, reviewing permit applications that involve specimen collection, including providing advice on where the specimens will be housed (in a NPS or non-NPS repository), and providing guidance to researchers on the collection, documentation, preparation and mounting, cataloging, and submission of specimens. Curators also manage loans of specimens to other institutions for research and repository purposes.

3. *What kinds of specimens are in NPS natural history collections?*

Typical specimens in NPS collections include but are not limited to:

- Biological Collections: vascular and non-vascular plant, fungus, insect, arachnid, other invertebrate (such as snail), reptile, amphibian, fish, bird, and mammal specimens.
- Geological Collections: rocks, minerals, surface process samples, and soils.
- Paleontological Collections: plant, animal, and trace fossils.

These collections are preserved using methods and conditions that vary from dry to fluid to low-temperature to microscopic. For additional information, refer to Appendix Q: Curatorial Care of Natural History Collections; Appendix T: Curatorial Care of Biological Collections; Appendix U: Curatorial Care of Paleontological and Geological Collections; and *Museum Handbook*, Part II, Appendix H, Natural History.

4. *Why are natural history collections important?*

Natural history collections provide:

- Baseline documentation over time for science, resource management and interpretation
- Vouchers for research, documenting the existence of a physical or biological component at a given place and time
- Holotype specimens used to formally describe a new taxon
- Specimens of special historical value
- Specimens indicating ecological condition
- Specimens that may be used for future destructive sampling

- Specimens that may be used in exhibits or interpretive and education programs
- Documentation of change in natural conditions over time and response of physical and biological components to that change
- Evidence of human-caused environmental changes (such as variations in land use patterns or road building) and response of physical and biological components to those changes
- Documentation of the effects of NPS management decisions
- Indication of gaps in knowledge of park natural resources

Natural history collections are integral to resource management, science, and education in the parks.

5. *What characterizes NPS biological collections?*

Park biological collections consist of Monera, Fungi, Plantae, Protista, and Animalia specimens, generally collected within park boundaries. Collections of plant, fungi, monera, and protista that are separately assembled and managed are called herbaria. Most parks have a herbarium as part of their museum collection.

The collections document the non-human biology of the park at a given time and place. When researchers make observations about the park environment, they often collect voucher specimens to vouch for, or testify to, their observations. If these specimens are not destroyed or consumed in analysis, they become part of the park's collection. NPS has an ongoing program to inventory and monitor living resources in the parks that generates many specimens for the museum collections. Parks may manage collections on site or off site in collaboration with another park, an NPS center, or a partner repository, such as a regional or university museum. Many park biological collections are on loan to partner repositories for management.

Over time, NPS biological collections can help document changes in the park environment and changes in species thus helping to inform park planning, natural resource management, cultural landscape management, and interpretive programs. For example, the Yosemite National Park collection has 50 specimens of the foothill yellow-legged frog, *Rana boylei*, which were collected in the 1930s by the Yosemite Field School. This frog has now been extirpated from the region (Hitchcock 1994).

Major park herbaria are listed in the Index Herbariorum, which the New York Botanical Garden maintains at <http://sciweb.nybg.org/science2/IndexHerbariorum.asp>. Such listing increases worldwide awareness of and access to park herbaria.

6. *What are some examples of NPS biological collections?*

Examples of biological collections include:

- pressed plants mounted on herbarium sheets

- specimens mounted on microscope slides (such as algae and pollen)
- seeds
- bones (osteological collections)
- eggs
- animal skins
- animal tissues or whole animals preserved in liquid
- mounted or freeze-dried animal specimens
- marine and fresh water shells
- insects mounted on pins
- casts of tracks and tunnels
- nests
- live strains of microorganisms, such as bacteria, fungi, and protozoa

Examples of park biological collections include:

- Herbarium at Yellowstone National Park
- Microbial strains developed from specimens from multiple park collections at a repository that makes them available for laboratory research (see <http://www.atcc.com/common/specialCollections/NPS.cfm>)
- Tree snail collection at Everglades National Park
- Specimens from Great Smoky Mountains National Park documenting the park's All Taxa Biodiversity Inventory

7. *What disciplines collect and study biological collections?*

The disciplines that study biological collections are many. The most common in parks are:

- Botany (plants)
- Entomology (insects)
- Herpetology (reptiles and amphibians)
- Ichthyology (fish)
- Limnology (study of inland waters, saline and fresh)
- Malacology (mollusks)

- Mammalogy (mammals)
- Ornithology (birds)

8. *What characterizes NPS geological collections?*

Geological specimens document the presence of geological materials and the processes that influenced them. For example, in a rock specimen, the mineral composition, structure and texture reveal the origin of the unit from which the specimen came (such as a granitic pluton). The surface may show the physical processes of its most recent history (such as glacial striations). Its chemical alteration may record the weathering process it has experienced through the breakdown of feldspars and oxidation and hydration of other minerals.

We can learn about a rock's	By looking at
Origin	Mineral composition
	Structure
	Texture
History	Physical processes, such as glacial striations
	Weathering processes, both mechanical and chemical, such as oxidation
Age	Direction and strength of the earth's magnetic field when it formed, breakdown of radioactive elements

Geological collections can include:

- rocks
 - igneous (volcanic rocks, such as obsidian, lava, and tephra; or intrusive rocks such as granite)
 - sedimentary (rocks formed by deposition via wind and water, such as shale, sandstone, limestone)
 - metamorphic (rocks transformed under heat and pressure, such as schist, gneiss, marble)
- mineral specimens (such as quartz, malachite, and calcite)
- surface process materials, such as evidence of desert varnish or glacial action
- ores (often associated with historical mines in parks)
- samples of cave formations
- soils

- building stone samples
- extraterrestrial materials, such as meteorites
- environmental samples (such as air and water)

Geological collections can inform park planning and development (for example, knowledge of rock types helps planners select sites for buildings); natural and cultural resources management (for example, a soil analysis may suggest reasons for the prehistoric abandonment of an archeological site); and interpretation.

9. *What are some examples of geological specimens in NPS collections?*

Examples of geological specimens in NPS collections include:

- Agate, chalcedony, and quartz specimens at Badlands National Park
- Sandstone and basalt specimens at Zion National Park
- Slate, quartz, and schist specimens at Bering Land Bridge National Preserve
- Calcite, gypsum, and limestone specimens at Mammoth Cave National Park
- Granite, marble, and ore sample specimens at Sequoia and Kings Canyon National Parks.

10. *What characterizes NPS paleontological collections?*

Paleontology specimens are fossils of plants and animals and naturally occurring tracks, impressions and casts. They record past life on earth. In addition, the collections often include human-made molds and casts of specimens. In size, fossils range from microscopic pollen and spores studied with scanning electron microscopes to dinosaurs 100 feet in length.

Although the primary NPS paleontological collections reflect the resources in parks that were established specifically for their paleontological significance, paleontological resources occur in parks throughout the system. NPS paleontological collections cover the entire span of geological time and represent all five kingdoms of life (Monera, Protista, Fungi, Plantae, and Animalia), but most park paleontological collections are identified as:

- vertebrates
- invertebrates
- plants

Fossils can be divided into two main categories—body fossils and trace fossils—as follows:

Body Fossils	Trace Fossils
Petrified wood Fossil bones Fossil plants Fossil tissue Fossil pollen	Tracks Trails Burrows Borings Gnaw or bite marks Casts Coprolites (fossilized feces)

11. *What are some examples of paleontological specimens in NPS collections?*

Examples of fossils in NPS collections include:

- Sauropod (the largest land animal) specimens at Dinosaur National Monument
- Fish at Fossil Butte National Monument
- Insects and leaves at Florissant Fossil Beds National Monument
- Fossilized logs at Petrified Forest National Park
- Camel, rhinoceros, and sloth specimens at John Day Fossil Beds National Monument
- Mastodon, saber-toothed cat, and horse specimens at Hagerman Fossil Beds National Monument
- Sponges, brachiopods, and trilobites at Guadalupe Mountains National Park

These examples illustrate the diversity of NPS paleontological collections. For additional information, refer to Appendix U: “Curatorial Care of Paleontological and Geological Collections.”

12. *What specialties are represented in the discipline of paleontology?*

The discipline of paleontology has several subdisciplines. For example:

- Paleobotany (the study of fossil plants)
- Vertebrate paleontology (the study of animals with backbones)
- Invertebrate paleontology (the study of animals without backbones)
- Palynology (the study of pollen and spores, both living and fossil)
- Paleoclimatology or paleoecology (the study of past climates and ecology)
- Ichnology (the study of fossil tracks, trails, and footprints)
- Micropaleontology (study of microscopic fossils)
- Taphonomy (study of the processes of decay, preservation, and the formation of fossils)

13. *How have park natural history collections developed over time?*

The development and organization of park natural history collections has reflected park needs related to interpretation and education, management, and research. The parks that were established primarily for their natural resources developed scientific collections early in their history. These nonrenewable collections document change in conditions, species, and habitat over time. For example, soon after Great Smoky Mountains National Park was established in 1934, the superintendent gave priority to forming a study collection to document park resources.

Many park naturalists (today's interpretive rangers) started collecting specimens for use in public education programs and those collections have subsequently become important for science and resource management. For example, at Everglades National Park, a Florida cougar skull, collected solely for exhibit in the 1960s, later became important for its scientific value in helping to resolve taxonomic questions regarding the description of the subspecies *Felis concolor coryi* (now *Puma concolor coryi*), (Hitchcock 1994). Although some park collections started around the turn of the century, many natural history collections were begun in the 1920s and 1930s. These collections now form important baseline data for the parks.

Park naturalists and associated researchers (primarily those with government agencies, universities, or large museums) have long collected specimens from parks. In many cases these collections pre-date the establishment of the park. For example, the Jepson Herbarium at the University of California, Berkeley, has early collections from Yosemite and Sequoia National Parks. Because research on park collections furthers the mission of the parks, parks welcome researchers and often assist with funding or in-kind contributions to the research effort.

14. *What has driven recent growth of NPS natural history collections?*

In the latter part of the 20th century, NPS became concerned that it lacked good documentation, vouchers, and results from the many research projects on park lands. These projects had collected important baseline data, yet parks often did not know where or how to access it. In response, NPS promulgated a new regulation that became effective April 30, 1984, requiring that all specimens collected in parks and retained in museum collections have NPS labels and be cataloged in the NPS National Catalog. This regulation and standardization of the permitting system in 2001 have contributed significantly to the ability of parks to track and use research information and specimens, whether the collections and associated records are managed at the park, at another park or NPS center, or on loan to a non-NPS repository, such as a university or a natural history museum.

In 2000, under the Natural Resource Challenge, NPS initiated the NPS Inventory and Monitoring Program to provide NPS managers with the information and expertise needed to maintain ecosystem integrity. For example, NPS scientists are currently conducting baseline inventories of basic biological and geophysical natural resources for all natural resource parks. These inventories result in collections of both specimens and corresponding data, in various forms. This initiative has accelerated the growth of park natural history collections. Currently, natural history collections represent two percent of the total NPS museum collections.

15. *What determines how NPS natural history collections are used?*

Collections use depends on:

- available documentation and access venues, such as ANCS+, Web Catalog, Index Herbariorum
 - the specimens or parts available
 - available expertise
 - methods of preservation
 - preservation quality
-

H. Introduction to NPS Museum Collections Management

1. *What are the main elements of NPS Museum Collections Management?*

Collections management is a process, not a product. It is a systematic approach to the proper documentation, preservation and use of museum objects—one that allows for public and research access while at the same time providing preventive care and long-term stewardship of these resources.

Collections management includes any activity associated with the acquisition, accountability, documentation, conservation, protection, disposition, and use of museum objects. It involves:

- assessing and prioritizing both short and long-term curatorial needs
- effective short-term and long-range planning to address those needs
- carrying out the daily activities necessary to properly care for the collection

The goal of collections management is to make museum collections available for exhibit and research use while simultaneously preserving them for future generations.

2. *What policy guidance is available on managing NPS museum collections?*

The following documents, which are available at <http://data2.itc.nps.gov/npspolicy/index.cfm>, provide guidance that is particularly relevant to NPS museum collections.

- *Management Policies*—key chapter citations are
 - 3. Land Protection (specifically 3.3 Land Protection Plans)
 - 4. Natural Resource Management (especially 4.2 Studies and Collections [all sections]; 4.8.2.1 Paleontological Resources and Their Contexts)

- 5. Cultural Resource Management
 - 7. Interpretation and Education (especially 7.3.2 Non-personal Services; 7.5.5 Consultation; 7.5.7 Historic Weapons)
 - 8. Use of the Parks (especially 8.6 Special Park Uses; 8.10 Natural and Cultural Studies Research and Collection Activities; 8.11.3 Independent and Commercial Studies)
 - 9. Park Facilities (especially 9.3.1.3 Visitor Centers; 9.4.2 Museum Collections Management Facilities)
 - 10. Commercial Visitor Services (specifically 10.2.4.9 Natural and Cultural Resource Management Requirements; 10.2.4.6 Artifacts and Specimens)
- Director’s Order #6: Interpretation and Education
 - Director’s Order #19: Records Management
 - Director’s Order #20: Agreements
 - Director’s Order #21: Donations and Fundraising
 - Director’s Order #24: NPS Museum Collections Management (DO #24)
 - Director’s Order #28: Cultural Resource Management
 - Director’s Order #28A: Archeology
 - Director’s Order #28C: Oral History
 - Director’s Order #29: Ethnography Program (in process)
 - Director’s Order #44: Personal Property Management
 - Director’s Order #53: Special Park Uses
 - Director’s Order #58: Structural Fire Management
 - Director’s Order #84: Library Management (in process)
 - Records Disposition Schedule and *Records Management Handbook*
 - NPS-28 *Cultural Resource Management Guideline*
 - *Museum Handbook*, Parts I-III
 - *Property Management Handbook*
 - *Reference Manual 77: Natural Resource Management*

3. *What are the levels of responsibility for NPS collections management?*

Every park with a museum collection is part of the larger NPS museum system. Although responsibility for managing these collections is shared among the Washington Office, the regional offices, parks, centers, and park partners, the superintendent is the accountable official for the park's museum collections regardless of the location of the collection. All individuals with responsibility for museum collections must follow the Code of Ethics (see *Museum Handbook*, Part I, Appendix D).

4. *What are the museum management responsibilities of the Washington Office?*

As described in DO #24, the Associate Director, Cultural Resources, with the assistance of the Chief Curator and the Park Museum Management Program, has the following responsibilities:

- Develop and oversee policies and procedures for NPS museum collections.
- Develop, issue, and periodically update the *NPS Museum Handbook*.
- Develop strategic plans and goals to improve and maintain the management of NPS museum collections servicewide.
- Maintain the National Catalog of Museum Objects and its automated version, ANCS+ (and its successor).
- Maintain, analyze, and report on annual data that parks, centers, and regions, submit including:
 - Collections Management Report
 - NPS Checklist for Preservation and Protection of Museum Collections
 - Annual Inventory of Museum Property
 - Funding distributions and accomplishments
- Research products and facilitate park and center acquisition and use of appropriate supplies, forms, equipment, and technologies for management of museum collections.
- Develop and coordinate servicewide initiatives and funding to improve museum management.
- Publicize and disseminate technical information on museum management, such as the *Conserve O Gram* series.
- Develop and maintain access to servicewide information about NPS museum collections through various media, including ANCS+ and the Web.
- Evaluate and coordinate servicewide professional competencies and training needs and develop strategies, guidelines, and curricula to meet those needs. Coordinate training to address new technologies,

programs, and initiatives.

- Review draft park plans that receive WASO review, such as General Management Plans, for appropriate coverage of museum management.
- Provide technical assistance and advice to park and center managers regarding museum collections management.

5. *What are the museum management responsibilities of the Regional Offices?*

As described in DO #24, regional directors, assisted by the regional curator and other museum management staff, have the following responsibilities:

- Conduct plan and performance reviews to ensure that superintendents and center managers meet their responsibilities to manage museum collections according to NPS requirements.
- Provide technical assistance and advice to park and center managers regarding museum collections management.
- Evaluate museum management staffing and training needs, and develop and provide training to park and center staff.
- Develop plans and set priorities (including funding priorities) for managing museum collections based on all approved planning documents and information provided through servicewide reports and requirements.
- Review park and center annual inventories, take any necessary corrective actions, and annually certify to the Associate Director, Cultural Resources, that parks and centers have completed their annual inventories.
- Approve destructive analysis and consumptive use of museum collections. After careful review, if the benefits can be clearly shown to outweigh the resulting or potential damage or loss, the Regional Director may approve destructive analysis of rare or highly significant objects, specimens, and archival items, and consumptive use of museum collections.
- Grant exceptions to the unconditional gift policy on a rare and case-by-case basis, when justified.

6. *What are the museum management responsibilities of the parks and centers?*

As described in DO #24, park superintendents, center managers, and others who manage collections (with the assistance of the curator and other museum management staff) have the following responsibilities. See DO #24 for additional detail and submission and reporting requirements.

- Meet the museum management standards and follow the procedures outlined in the *NPS Museum Handbook*.

- Provide ongoing funding for recurring museum management functions.
- Identify, prioritize, and correct preservation, protection, documentation, and access and use deficiencies, including programming for funding to correct such deficiencies.
- Complete Project Management Information System (PMIS) project statements that identify all preservation, protection, documentation, access, and use needs.
- Evaluate and address museum management staffing and training needs according to established personnel qualifications standards and servicewide professional competencies.
- Approve and keep current a Scope of Collection Statement. Ensure acquisitions are consistent with the Scope of Collection Statement and deaccession those objects that are inconsistent with the statement.
- Approve, keep current, and implement the following plans:
 - Collection Management Plan
 - Housekeeping Plan
 - Integrated Pest Management Plan
 - Museum Collections Emergency Operations Plan (part of the park's Emergency Operations Plan)
- Ensure that staff is practiced and prepared for emergency response.
- Prepare a job hazard analysis for all museum jobs that have an associated history of injury, illness, or death; or that require the use of personal protection equipment; or that involve activities that are clearly dangerous.
- Monitor and record information about the environment in spaces housing collections and manage the environment to maximize preservation and complete Collection Condition Surveys, as needed.
- Accession collections upon acquisition to establish basic accountability.
- Catalog collections immediately following acquisition, or program to catalog them in the near future.
- Survey, appraise, rehouse, arrange, and describe archival and manuscript collections and prepare finding aids. Develop park archival duplication and reference procedures.
- Maintain a complete and current backup of all electronic accession

and catalog records at a second, separate location. Submit a complete annual backup to the National Catalog in Harpers Ferry, WV.

- Accept only unconditional gifts and bequests and obtain applicable copyrights and releases with acquisitions.
- Require all project budgets to include funding for the preparation, documentation and initial storage of collections that are project-generated.
- Add collections made through systematic research to the museum collection. As appropriate, lend these collections for exhibit, research, conservation, and other approved uses.
- Annually complete the following reports:
 - Collections Management Report
 - Annual Inventory of Museum Property
 - NPS Checklist for Preservation and Protection of Museum Collections
- Document treatment of collections, and record that information in ANCS+.
- Promote access to cataloged collections for research and interpretive purposes through a variety of means, such as exhibits, interpretive programs, loans, publications, Web exhibits, and the Web Catalog. Post finding aids and repository level-guides for archival collections in the National Union Catalog of Manuscript Collections (NUCMC).
- Ensure that access and use are consistent with all laws and NPS policies.
- Document access and use of collections.
- Consult with affiliated groups in managing collections, including Native American groups when managing collections subject to the Native American Graves Protection and Repatriation Act.
- Manage objects to preserve their condition, including using reproductions when originals may be damaged by use. When appropriate, approve destructive analysis, except for rare or highly significant items.
- Exhibit collections according to an approved exhibit plan, accompanied by maintenance instructions. Ensure that all exhibits meet the standards in the NPS Checklist for Preservation and Protection of Museum Collections.
- Document furnishings that are exhibited in their associated historic structures with an approved Historic Furnishings Report. Consider the

preservation requirements of both objects and historic structures when objects are on exhibit or in storage in historic structures.

- Never exhibit Native American human remains or photographs, drawings or renderings, or casts of the remains. Exhibit non-Native American human remains and photographs, drawings or renderings, or casts of the remains only in consultation with traditionally associated groups.
- Ensure that approved museum plans are entered in the Cultural Resource Management Bibliography (CRBIB).

7. *What additional roles do the servicewide centers have?*

The **Harpers Ferry Center** (HFC) coordinates the planning, design, production, and rehabilitation of museum exhibits and exhibits of historic furnishings. It also coordinates publications, wayside exhibits, and audiovisual programs. It provides conservation services for exhibit production and, on a reimbursable basis, provides other conservation services for parks, such as collection condition surveys, advising on environmental conditions and storage techniques, providing treatments, and training park staff in preventive conservation. Other services are interpretive planning, audiovisual equipment repair, graphics research, replacement of wayside exhibits, and the revision and reprinting of publications. The center also maintains the NPS history collection with documents, photographs and objects representing NPS administrative history. See <http://www.nps.gov/hfc/>.

The **Denver Service Center** (DSC) provides major planning, design, and construction services to parks, regions, architecture/engineering firms, and other partners. DSC provides these services jointly with private industry. DSC's projects are worldwide—ranging from designing a mass transit system in Zion National Park in Utah, to planning and designing the FDR Memorial in Washington, DC, to assisting Sri Lanka and other countries with their emerging park systems.

I. Planning for Park Museum Collections

1. *What general park plans are relevant to planning for park museum collections?*

The following integrated planning framework, as described in *Management Policies*, Chapter 2, guides park decisions and management.

- Foundation Statement
- General Management Plan
- Program Management Plans
- Strategic Plans
- Implementation Plans
- Annual Performance Plans and Reports

2. *What does the Foundation*

The Foundation statement is a succinct statement describing the park

- Statement say about the museum collection?*
- purpose, significance, fundamental resources (including the museum collection) and values, and primary interpretive themes. It is based on the park's establishing legislation or Presidential Proclamation.
3. *How does the General Management Plan relate to the museum collection?*
- The General Management Plan (GMP) is a park's primary planning document. It sets the long-term goals for the park based on the Foundation Statement. It clearly defines the desired natural and cultural resource conditions, including the museum collection, the conditions necessary to support the desired visitor use, and the management actions and standards to maintain these conditions. The management prescriptions identified in a park's General Management Plan are applied parkwide by resource topic and by specific geographic area as a management zone. All subsequent park planning documents flow from the GMP.
4. *What program management plans are specific to the museum collections?*
- Program management plans describe program-specific measures or strategies to achieve and maintain the desired resource conditions and visitor experiences. Program-specific plans that address museum collections documentation, preservation, access, and/or use include but are not limited to:
- Scope of Collection Statement
 - Collection Management Plan
 - Park Resource Stewardship Plan
 - Comprehensive Interpretive Plan
5. *How does the park Strategic Plan address museum collections?*
- Strategic planning addresses performance management and accountability. NPS policies require that the National Park Service as a whole, and every park, program, and central office have its own strategic plan.
- A park's strategic plan is based on the park's mission goals, GMP, and the NPS and Department of the Interior strategic plans.
- The two servicewide goals that measure performance specific to museum collections are:
- Ia6 Museum Collections: Percentage of preservation and protection standards for park museum collections met
 - Ib2D Museum objects cataloged
- All parks with museum collections must include these servicewide goals in their strategic plans. Parks may include additional park-specific goals related to their museum collections.
6. *What is an implementation plan for*
- An implementation plan focuses on activities and projects needed to achieve the desired conditions identified in the GMP, strategic plan, and

museum collections?

program management plan. Examples of implementation plans for museum collections include:

- Collection Management Plan
- Housekeeping Plan
- Museum Emergency Operations Plan
- Integrated Pest Management Plan
- Collection Condition Survey
- Historic Furnishings Report
- Exhibit Plan
- Museum Security Survey
- Museum Fire Protection Survey
- Storage Plan

Implementation plans may also be project-specific plans, such as a plan to catalog the backlog of uncataloged collections, or a plan to install data loggers in all museum spaces.

7. *What are Annual Performance Plans and Reports?*

Each park prepares an Annual Performance Plan that is tied to its Strategic Plan. The Annual Performance Plan includes:

- Annual goals (the outcomes expected to be achieved). For example: “In FY2007, the park will catalog 2000 geology specimens.”
- An annual work plan, which allocates budget and personnel needed to accomplish the work.

Each park also prepares an Annual Performance Report that documents progress in meeting the annual goals.

8. *What are the requirements for museum-specific planning documents?*

DO #24 requires all parks to have the following planning documents specific to museum collections:

- Scope of Collection Statement (SOCS). The SOCS is a stand-alone museum planning document that succinctly defines the scope of the park’s museum collection holdings at the present and for the future. The SOCS derives from the park’s mission, as well as laws and regulations mandating the preservation of collections. See Chapter 2: Scope of Museum Collections for additional information.
- Collection Management Plan (CMP). All parks must have an up-to-date, approved, and implemented Collection Management Plan (CMP). A park’s CMP:

- evaluates issues of preserving, protecting (including security and fire protection), documenting, accessing, and using collections.
 - addresses issues specific to archival and manuscript collections (appraising, arranging, describing, producing finding aids, and providing reference and duplication services).
 - proposes a strategy to address the issues, including staffing and cost estimates.
- Housekeeping Plan. Every space that houses museum collections must have an approved, current, and operational Housekeeping Plan. A current Housekeeping Plan that the staff consistently follows ensures that housekeeping routines are sensitive to museum collections preservation needs.
 - Museum Emergency Operations Plan (MEOP). Parks must have an operational, approved, and current MEOP. The MEOP is part of the park's Emergency Operations Plan (EOP). The MEOP identifies:
 - museum collection vulnerabilities to events (such as fire, earthquakes, and floods)
 - responses that will protect resources without endangering human health and safety
 - strategies to implement appropriate pre-plans and carry out scheduled and unscheduled drills, exercises, briefings/meetings, and training opportunities to ensure that all park employees are prepared for emergency response

For additional information, refer to Chapter 10: Emergency Planning, *Conserve O Grams 21/9 – 21/11*, and the National Fire Protection Association's publication *NFPA 1600: Standard for Disaster/Emergency Management and Business Continuity Programs*.

- Museum Integrated Pest Management Plan (IPM Plan). Parks must have an approved, current, and implemented IPM Plan that specifically addresses the museum collections. The museum IPM Plan can be either a stand-alone document or part of the recognized parkwide IPM program.
- Collection Condition Survey. DO #24 requires parks to monitor and record information about the environment in spaces housing collections, manage the environment to maximize preservation, and complete Collection Condition Surveys (CCS), as needed, to assess conditions in spaces housing museum collections.
- Historic Furnishings Report (HFR). The HFR documents furnishings exhibited in associated historic structures. The HFR documents the history of a structure's use and interior appearance, and, if appropriate, provides a plan for recreating and/or maintaining the

historic interior. The furnishings plan addresses interpretive objectives, operating plans that include recommendations for staffing and visitor circulation, and detailed plans for furnishing. Guidelines for furnishings installation and maintenance are included. The HFR must consider the preservation requirements of both objects and historic structures.

- Exhibit Plan. The Exhibit Plan provides the label copy and detailed design and construction plans. It must also address the preservation and security needs of exhibited objects. The plan and design must include specifications for environmental needs (for example, relative humidity, temperature, light, and dust control), security, and access to exhibit cases for maintenance and management. The plan ensures that all exhibits meet the standards in the Museum Checklist.

Other museum-specific plans that are included as a standard on the Museum Checklist are:

- Museum Security Survey. All parks must implement a Museum Security Survey and ensure that it remains current. It can be either a stand-alone document or part of a parkwide security survey. The regional curator and park chief ranger may assist in arranging for this specialized survey. See Chapter 9: Security and Fire Protection, for more information.
- Museum Fire Protection Survey. All parks must implement a Museum Fire Protection Survey and ensure that it remains current. It may be a stand-alone document or part of a parkwide fire protection survey. *Reference Manual 58: Structural Fire Management*, requires annual fire inspections of all NPS structures. Annual inspections do not assess the structure with the same level of detail as a complete fire protection survey; however, the annual inspections are an important part of the National Park Service's ongoing fire prevention and safety efforts. Consult the park structural fire coordinator, regional curator, and regional structural fire management officer for assistance. See Chapter 9: Security and Fire Protection, for more information.
- Collection Storage Plan. The park may require a stand-alone Collection Storage Plan (CSP) if this need has been identified on the park's Museum Checklist, in consultation with the regional curator. Not all parks need a CSP, as the Collection Management Plan addresses museum storage issues.

9. *Are there any other park planning documents that may impact museum collections?*

Yes, there are a number of other park program management and implementation plans that may impact museum operations. Examples include:

- Development Concept Plan (for the development of facilities)
- Vital Signs Network Monitoring Plan
- Fire Management Plan

- Cultural Landscape Report
- Historic Structure Report
- Archeological Overview and Assessment
- Ethnobotanical Study
- Other resource management plans

Many park planning efforts, when implemented, may impact museum operations. For example archeological compliance preliminary to or during construction may generate new objects and associated records; the construction of new facilities may provide space for museum operations; and the installation of new exhibits may increase visitation and staff responsibilities. Other park initiatives may similarly impact museum operations.

Effective communication is vital. So that you won't have any surprises (such as large unexpected accessions from park construction work, field projects, or upcoming exhibits planned around objects that aren't in the park's collection), be sure to keep inter-divisional lines of communication open. Involve other divisions in museum planning efforts. Likewise, make curatorial staff available to contribute to other planning efforts.

Planning teams composed of individuals with varied jobs, backgrounds, experience, and skill sets help to ensure that the team considers multiple perspectives, strategies, and methods and delivers an appropriate, well-considered product.

J. Ethics, Standards and Professional Associations

Professional associations have played an important role in the NPS museum program from its inception. Non-NPS museum professionals helped to create the vision for NPS museums (see sections C.2 and C.3) and professional associations and their members have provided ongoing support and guidance to NPS museums. Professional associations establish ethical guidance and standards that guide the actions and decisions of all museum employees, volunteers and board members. The associations offer training, publications, Web sites, conferences and professional development opportunities and work with government and foundations to gain recognition and funding for museums. The American Association of Museums (AAM) operates an accreditation program for museums in which the NPS participates (see *Museum Handbook*, Part I, Appendix B). NPS museum professionals have individual memberships in national and regional professional museum associations and support their associations by serving on councils and committees, presenting papers at conferences, and contributing to publications.

1. *What standards of ethical conduct apply to NPS museum professionals?*

As Federal employees, NPS museum professionals look first to the Standards of Ethical Conduct for Employees of the Executive Branch (5 CFR 2635), Employee Responsibilities and Conduct (43 CFR 20), the Supplemental Standards of Ethical Conduct for Employees of the

Department of the Interior (5 CFR 3501), and the criminal conflict of interest statutes (18 USC 201, 203, 205, 207-209) for guidance. The Code of Ethics for NPS Museums (see *Museum Handbook*, Part I, Appendix D) guides the decisions of employees and volunteers who manage NPS museum collections and museum functions. In addition, NPS employees with museum responsibilities are guided by the codes of ethics of professional associations, such as the Society of American Archivists and American Institute for Conservation. See a list of professional organizations and applicable codes of ethics in Appendix D, section D. As civil servants NPS employees work for and are responsible to the American public and have an obligation to act according to the law and the highest ethical standards.

2. *What other professional museum standards apply to NPS museums?*

Museum-related guidance in *Management Policies*, Director's Orders and related reference manuals, and the *NPS Museum Handbook* provides NPS staff with standards and procedures for preservation, protection, documentation, and access to and use of NPS collections. These documents adopt and promulgate the generally accepted standards of the museum profession, and, in some cases, incorporate the codes of ethics of other organizations by reference. The *Museum Handbook* provides guidance on and reference to the code of ethics, standards, and required and recommended procedures that employees and volunteers with responsibility for NPS museum collections follow. Each chapter and appendix contains a selected bibliography.

Park planning documents (see section I) provide park-specific guidance for management of the museum collections, consistent with professional standards and NPS standards and procedures. An up-to-date CMP provides information on the collection's current status, recommendations for improvements, prioritization strategies, and suggestions concerning long-range and short-term planning, programming, funding, and training. If the CMP is out-of-date, note this deficiency on the Museum Checklist, prepare a PMIS Project Statement to fund this work, and coordinate with the regional curator.

If the park's CMP is out-of-date, ask the regional curator to provide a recent example from another park. Use that document to gain ideas for the park's museum program.

3. *How can the park and I benefit from what professional associations offer?*

NPS parks and offices may be institutional members of professional associations and NPS museum employees may be individual members. Membership establishes a lasting partnership that serves to enhance the mission, goals, and operations of the museum and the career of the individual. Professional associations provide not only codes of ethics and standards, but opportunities for growth, inspiration for change, and guidance and support in challenging situations. Each association has a different focus. You will need to decide which associations best match the park's and your needs.

Selected professional museum-related associations are described below. Additional associations and contact information are in Appendix D, NPS Code of Ethics.

- **American Association for State and Local History** - The American Association for State and Local History (AASLH) is a national non-profit organization that serves organizations and people who work to preserve and interpret history, including historical societies, museums, historic sites, parks, libraries, archives, historic preservation organizations, and schools and colleges. The association has adopted and published the “AASLH Statement of Professional Ethics.” Publications include a quarterly magazine, *History News*, and a monthly newsletter, *Dispatch*. The association produces and sells publications and educational materials (such as books, technical leaflets, reports, and video programs) on the documentation, preservation, and interpretation of history, including the care and conservation of museum objects. The association sponsors seminars, workshops, and an annual meeting.

Contact: American Association for State and Local History
1717 Church Street
Nashville, TN 37203
(615) 320-3203
www.aaslh.org

- **American Association of Museums** - The American Association of Museums (AAM), founded in 1906, addresses the concerns of the country's museum community. The association represents art and natural history museums, zoos, botanical gardens, arboretums, planetariums, science and technology centers, nature centers, children's museums, and history museums, historic sites, and historical societies. Members include museum directors, curators, registrars, educators, marketing and development directors, public relations personnel, and others. It offers institutional, individual, and commercial memberships.

The AAM's Accreditation Program (see *Museum Handbook*, Part I, Appendix B) is a leader in establishing professional standards for museums and museum professionals. Publications include a bi-monthly journal, *Museum News*, and a monthly newsletter *Aviso*. The AAM bookstore stocks publications that address topics such as collections management, museum ethics, conservation, marketing, and fundraising. The association holds an annual meeting.

Contact: American Association of Museums
1575 Eye Street, NW, Suite 400
Washington, DC 20005
(202) 289-1818
<http://www.aam-us.org>

- **American Institute for Conservation of Historic and Artistic Works** - The American Institute for Conservation of Historic and Artistic Works (AIC) addresses the concerns of the conservation profession. Members include conservators who practice in all of the material specialties (such as, paintings, books and paper, textiles, wood, photographic materials, architecture, electronic media, and

objects of leather, ceramic, glass, metal, and stone) and conservation scientists. Librarians, archivists, and curators may also be members. This organization has adopted and published the “AIC Code of Ethics and Guidelines for Practice” for the conservation profession in the United States. Publications include the *Journal of the American Institute for Conservation* (published three times a year) and the bimonthly newsletter, *AIC News*. The newsletter includes information from the various specialties, health and safety updates, preventive conservation information, and a list of conferences, courses, and seminars. The association sponsors an annual meeting, including a pre-meeting workshop. The association also publishes an annual directory of its membership. It offers institutional and individual memberships.

Contact: American Institute for Conservation of Historic and Artistic Works
1717 K Street, NW, Suite 200
Washington, DC 20006
(202) 452-9545
<http://aic.stanford.edu/>

- **Society of American Archivists** - The Society of American Archivists (SAA), founded in 1936, promotes the preservation and use of archival materials (such as, documents, manuscripts, films, maps, photographs, sound recordings, and machine-readable records). This organization provides a wide range of educational workshops, maintains an active publications program, and promotes cooperation, growth, and development in the archival field. The society has adopted and published “A Code of Ethics for Archivists with Commentary.” Publications include a semi-annual journal, *American Archivist*, and a bimonthly newsletter, *Archival Outlook*. The SAA’s publication program offers basic manuals on the arrangement, description, access, conservation and care, and exhibition of archival collections. The society sponsors an annual meeting. It offers institutional and individual memberships.

Contact: Society of American Archivists
527 South Wells Street, 5th Floor
Chicago, IL 60607
(312) 922-0140
<http://www.archivists.org>

- **Society for the Preservation of Natural History Collections** - The Society for the Preservation of Natural History Collections (SPNHC) represents the interests of natural history collections and the people associated with the management and care of these collections. Membership includes individuals from the fields of anthropology, botany, geology, paleontology, zoology and others interested in the development and preservation of natural history collections. Publications include a journal, *Collection Forum*, a newsletter, *SPNHC Newsletter*, and the “Guidelines for Care of Natural History Collections.” The journal, published twice a year, provides up-to-date technical and documentary information on the care of natural history

collections. The society conducts annual meetings that include formal presentations and workshops. It offers individual, library, and institutional (associate/corporate) memberships.

Contact: Society for the Preservation of Natural History
Collections
PO Box 797
Washington, DC 20044
(202) 786-2426
<http://www.spnhc.org>

- **International Council of Museums** - The International Council of Museums (ICOM) is an international non-governmental organization (NGO) which is "...committed to the conservation, continuation and communication to society of the world's natural and cultural heritage, present and future, tangible and intangible," (2004). ICOM is affiliated with the United Nations Educational, Scientific and Cultural Organization (UNESCO) and carries out part of UNESCO's program for museums.

ICOM initiatives include: "...professional cooperation and exchange, dissemination of knowledge and raising public awareness of museums, training of personnel, advancement of professional standards, elaboration and promotion of professional ethics, [and] preservation of heritage and combating the illicit traffic in cultural property," (2004).

To raise global awareness of museum issues, ICOM sponsors "International Museum Day" each May 18. The organization has adopted the "ICOM Code of Ethics for Museums." It offers institutional and individual memberships.

Contact: ICOM Secretariat
Maison de l'UNESCO
1, rue Miollis
75732 Paris Cedex 15
France
Tel: 011+33 (0) 1 47.34.05.00
<http://icom.museum>

- **State and Regional Museum Associations** - Regional museum organizations are good resources for professional standards, training, and networking. Many states have statewide museum associations as well. The American Association of Museums has six affiliated regional museum associations (see <http://www.aam-us.org/aboutaam/councils/region/index.cfm>). Consult the NPS regional curator for additional information on such organizations serving your area.

K. Selected Bibliography

Alexander, Edward P. *Museums in Motion: An Introduction to the History and Functions of Museums*. Walnut Creek, CA: Altamira Press, 1979.

- _____. *Museum Masters: Their Museums and Their Influence*. Walnut Creek, CA: Altamira Press, 1983.
- Anderson, Gail (ed.). *Reinventing the Museum: Historical and Contemporary Perspectives on the Paradigm Shift*. Walnut Creek, CA: Altamira Press, 2004.
- Burns, Ned J. *National Park Service Field Manual for Museums*. Washington, DC: United States Government Printing Office, 1941.
- Cato, Paisley S., Julia Golden and Suzanne B. McLaren. *Museum Wise: Workplace Words Defined*. Washington, DC: Society for the Preservation of Natural History Collections, 2003.
- Edson, Gary and David Dean (eds.). *The Handbook for Museums*. London: Routledge, 1996.
- Fahy, Anne (ed.). *Collections Management*. London: Routledge, 2002.
- Goode, George Browne. *The Principles of Museum Administration*. New York: Coultas and Volans, 1895.
- Hitchcock, Ann. "Archeological and Natural Resource Collections of the National Park Service: Opportunities and Threats," *Curator* 37/2 (1994): 122-128.
- _____. *NPS Museums 1904-2004*. <http://www.cr.nps.gov/museum/centennial/about.html>, April 2004.
- _____. "The National Park Service Museums Centennial, 1904-2004," *History News*, Nashville: American Association for State and Local History 59/4 (2004): 12-16.
- Kavanaugh, Gaynor. *History Curatorship*. Leicester: Leicester University Press, 1990.
- _____. *Museum Provision and Professionalism*. London: Routledge, 2002.
- Lewis, Ralph H. *Manual for Museums*. Washington, DC: National Park Service, 1976.
- _____. *Museum Curatorship in the National Park Service, 1904-1982*. Washington, DC: National Park Service, 1993.
- Lord, Gail Dexter and Barry Lord. *The Manual of Museum Planning*. Walnut Creek, CA: Alta Mira Press, 2001.
- _____. *The Manual of Museum Management*. London: The Stationery Office, 2000.
- Malaro, Marie C. *A Legal Primer on Managing Museum Collections*. Washington, DC: Smithsonian Institution Press, 1993.

Chapter 2: Scope of Museum Collections

	<u>Page</u>
A. Overview	2:1
What information will I find in this chapter?	2:1
What other resources can help me prepare and implement my park's Scope of Collection Statement?	2:1
B. Museum Collections	2:1
What is a museum collection?.....	2:1
Why should parks acquire and manage museum collections?	2:2
Who can accept museum collections?	2:3
C. The Scope of Collection Statement	2:3
What is a Scope of Collection Statement?	2:3
Does every park require a Scope of Collection Statement?	2:3
Why does my park need a Scope of Collection Statement?	2:3
How do I determine the scope of my park's museum collection?	2:4
What is a park Collections Advisory Committee?.....	2:4
Are parks required to have a Collections Advisory Committee?	2:5
Who prepares and approves a Scope of Collection Statement?	2:5
What is the distribution of an approved Scope of Collection Statement?	2:5
How often should I review and revise my park's Scope of Collection Statement?	2:5
What are the parts of a Scope of Collection Statement?	2:5
What is the Executive Summary (Scope of Collection Summary)?	2:6
When should I use the Scope of Collection Summary?	2:6
D. Writing the Introductory Section of the Scope of Collection Statement	2:6
What should I include on the Title Page?.....	2:6
What should I include in the Executive Summary?	2:7
What should I include in the Table of Contents?.....	2:7
How do I prepare the Introduction?	2:7
What legal authorities should I reference?	2:7
What information should I include about the park's mission?	2:8
What information should I include about the purpose of the collection?	2:8
What park documents should I reference?.....	2:8
What should I include about mandated collections?	2:9
Should I include information on the significance of the collection?	2:9
What other references should I include in the Introduction?	2:10
E. Writing the Types of Collection Section	2:10
What should I include in the Types of Collection section?	2:10
What do I need to know about natural history collections to help me prepare the Types of Collections section?	2:12
What other information concerning natural history collections should I include in the Types of Collections section?	2:13
What do I need to know about cultural collections to help me prepare the Types of Collections section?	2:14
What other information concerning cultural collections should I include in the Types of Collections section?	2:14
What do I need to know about Archival and Manuscript Collections to help me prepare the Types of Collections section?	2:15

How do I determine if material belongs in the park library or the museum collection?	2:16
F. Writing the Museum Collections Subject to NAGPRA Section	2:17
What is NAGPRA?	2:17
What do I include in the SOCS about NAGPRA?	2:17
G. Writing the Acquisition Section	2:18
How do I prepare the Acquisition section?	2:18
What is some suggested wording for the Acquisition section?	2:19
H. Writing the Uses of Collections Section	2:20
How do I prepare the Uses of Collections section?	2:20
What is some suggested wording for the Uses of Collections section?	2:21
I. Writing the Restrictions Section	2:22
How do I prepare the Restrictions section?	2:22
What is some suggested wording for the Restrictions section?	2:23
J. Writing the Management Actions Section	2:24
How do I prepare the Management Actions section?	2:24
What is some suggested wording for the Management Actions section?	2:24
K. Implementing the Scope of Collection Statement	2:25
Does my park need to develop an acquisition strategy?	2:25
Is there a standard format for an acquisition strategy?	2:25
What other factors should we consider when developing our park's acquisition strategy?	2:26
What criteria should my park use to acquire collections?	2:26
Where can I find additional information concerning acquisitions?	2:28
What should I do if the collection includes museum objects that are not relevant to our park?	2:28
L. Selected Bibliography	2:28
List of Figures	
Figure 2.1 Example Scope of Collection Summary	2:29
Figure 2.2 Example Potential Museum Acquisitions Sheet	2:30

CHAPTER 2: SCOPE OF MUSEUM COLLECTIONS

A. Overview

1. *What information will I find in this chapter?*

In this chapter you will find answers to these questions:

- What is a museum collection?
- Who can accept a museum collection?
- What is a Scope of Collection Statement (SOCS)?
- Why does my park need a SOCS?
- How do I write a Scope of Collection Statement?
- Why should I include an Executive Summary (Scope of Collection Statement Summary)?
- How do I write a Scope of Collection Statement Summary?
- How do I implement a museum collection acquisition program?
- What criteria can I use to justify acceptance or rejection of museum objects?
- What is a Collections Advisory Committee?
- Who serves on a Collections Advisory Committee?

2. *What other resources can help me prepare and implement my park's Scope of Collection Statement?*

For additional information, see the:

- **Sample Scope of Collection Statement** in Appendix E: Scope of Collection Statement
- **Checklist for Evaluating a Scope of Collection Statement** in Appendix E
- **Bibliography** in Section L., at the end of this chapter

B. Museum Collections

1. *What is a museum collection?*

A museum collection is a group of artifacts (including archives) and/or scientific specimens that are relevant to the park's mission, mandates, history, and themes, and which the park manages, preserves, and makes available for access (through research, exhibits, and other media) for the public benefit.

The Departmental Manual (411 DM 1.3) defines museum property (museum collections) as:

“an assemblage of museum objects collected according to some rational scheme and maintained so they can be preserved, studied, or interpreted for public benefit. Museum objects include prehistoric and historic objects, artifacts, works of art, archival documents [historical and/or scientific documents collections as defined in the Departmental Museum Property Handbook, 411 DM Volume I, Appendix A, Section A.2.d.] and natural history specimens that are a part of museum collections. Elements, fragments, and components of structures are objects if they are no longer a part of the original structure. Museum property does not include those items necessary to display a collection such as exhibit cases, dioramas, special lighting, graphics, etc.”

Consult with your regional/SO curator and regional historical architect for guidance concerning accessioning structural components and historic fabric into your park’s collection.

Note: In rare instances, museum dioramas or exhibit cases may be considered museum property (such as dioramas constructed by the Civilian Conservation Corps) or historic fabric.

NPS *Management Policies* (2001), 5.3.5.5 “Museum Collections” states:

“The Service will collect, protect, preserve, provide access to, and use objects, specimens, and archival and manuscript collections (henceforth referred to collectively as ‘collections,’ or individually as ‘items’) in the disciplines of archeology, ethnography, history, biology, geology, and paleontology to aid understanding among park visitors and to advance knowledge in the humanities and sciences.”

2. *Why should parks acquire and manage museum collections?*

Chapter 9 of *Cultural Resource Management Guideline*, Release No. 5 (1997), which implements Director’s Order #28: Cultural Resource Management (June 1998), states:

“Museum collections (objects, specimens, and archival and manuscript collections) are important park resources in their own right as well as being valuable for the information they provide about processes, events, and interactions among people and the environment. Natural and cultural objects and their associated records provide baseline data, serving as scientific and historical documentation of the park’s resources and purpose. All resource management records that are directly associated with museum objects are managed as museum property. These and other resource management records are preserved as part of the archival and manuscript collection because they document and provide an information base for the continuing management of the park’s resources. Museum objects used in exhibits, furnished historic structures, and other interpretive programs help visitors gain better understanding of the events, activities, and people commemorated by parks.”

Museum collection records such as accession records, catalog records, loan records, conservation records, and inventory records are not included in the museum collection. They are official records that are generated in the course of doing government business. You must retain these records in association with museum collections. Do not catalog or include them as part of the park's museum collection. The management of these records is governed by Director's Order #19: Records Management (Jan 2001). Because they are used in the day-to-day management of the park collection, they are listed on the Records Disposition Schedule as being permanently retained in association with museum collections. See Museum Handbook, Part II (MH-II), Museum Records.

3. *Who can accept museum collections?*

By delegation, your park's superintendent represents the Director and the Secretary of the Interior in accepting title to and responsibility for museum collections. (See *MH-II*, Museum Records, Chapter 1, for guidance on delegation of authority and museum property management.)

Each park superintendent is responsible for ensuring that all collections acquired are in keeping with the Scope of Collection Statement before accepting the items as part of the permanent collection.

C. The Scope of Collection Statement

1. *What is a Scope of Collection Statement?*

A Scope of Collection Statement is a stand-alone museum planning document that succinctly defines the scope of the park's museum collection holdings at the present and for the future. The SOCS derives from the park's mission, as well as laws and regulations mandating the preservation of collections. It is:

- the critical basis for managing museum collections
- referenced in each park's General Management Plan, Resource Management Plan, Long-Range Interpretive Plan, and other planning documents that may affect the collection of museum objects or their management and use

2. *Does every park require a Scope of Collection Statement?*

Yes, all parks must have a Scope of Collection Statement. Although some parks may not intend to acquire a "typical" museum collection, each park will, at a minimum, possess archives documenting the history and management of the park, as well as objects and specimens generated from resource management activities. Other NPS organizational units (such as conservation centers, regional offices, or support offices) that acquire and maintain museum collections must also have a fully developed SOCS.

3. *Why does my park need a Scope of Collection Statement?*

A Scope of Collection Statement guides your park in the acquisition and management of those museum objects that contribute directly to the park's mission, as well as those additional collections that the Service is legally mandated to preserve. A SOCS:

- defines the purpose of the park’s museum collection
- sets agreed-upon limits that specify the subject matter, geographical location, and time period to which the collection must relate
- evolves from legislation and planning documents specific to each park, and from laws, regulations, and NPS policies governing research and specimen collection conducted within park boundaries
- states what types of objects will be acquired to fulfill the park’s mission
- considers collection use and restrictions

Director’s Order #24: NPS Museum Collection Management, 4.3.6 “Scope of Collections” states that NPS units with museum collections must:

“Approve and keep current a Scope of Collection Statement to identify the scope of collecting activities and define the purpose of the collection. Ensure acquisitions are consistent with the Scope of Collection Statement. Deaccession objects inconsistent with the Scope of Collection Statement.”

4. *How do I determine the scope of my park’s museum collection?*

To determine the scope of your park’s museum collection, you should:

- study the mission of the park as stated in its enabling legislation, presidential proclamation, executive order, or subsequent legislation that may revise a park’s mission.
- determine what cultural evidence and scientific information is needed to document and support the park’s resource management and interpretive programs.
- include archeological collections, certain natural history collections, and associated records that are mandated by law, regulation, and policy to be a part of the park’s museum collection.

5. *What is a park Collections Advisory Committee?*

A Collections Advisory Committee is chaired by the curator or collections manager and includes park staff who represent relevant disciplines (interpretation, natural resource management, archeology, and others). Committee members may also include subject matter specialists from neighboring parks and/or the regional office. The roles of the committee members are to:

- determine which of the park’s missions and programs are relevant to museum collections
- determine which types of museum objects the park will maintain to support those missions, programs, and mandates
- draft a new or revised SOCS for the park
- review and make recommendations to the superintendent concerning all potential additions by gift, purchase, transfer, exchange, and loan to the museum collection

- review and make recommendations to the superintendent concerning all potential deaccessions of objects determined to be outside the Scope of Collection
 - review and make recommendations to the superintendent concerning all potential deaccessions of objects that involve voluntary destruction or abandonment
6. *Are parks required to have a Collections Advisory Committee?*
- No, a Collections Advisory Committee is optional. However, you should consider establishing one. A committee with good representation from different park divisions and across various disciplines will allow for enlightened discussions reflecting diverse viewpoints, and eliminate any appearance of curatorial self-interest unduly influencing the park's acquisitions policies. Most professional museums have a Collections Advisory Committee. The guidance provided by this committee, combined with a well-written SOCS, should ensure that the museum collection is clearly relevant to your park's mission.
7. *Who prepares and approves a Scope of Collection Statement?*
- The curator, collections manager, or other park staff responsible for the collection (ideally with the assistance of the Collections Advisory Committee) prepares the Scope of Collection Statement. Be sure to coordinate the development of your SOCS with your regional/SO curator, as s/he can provide help. Following review by appropriate park staff (such as archeologists, interpreters, scientists, naturalists, historians, archivists, and other resource management staff) and your regional/SO curator, the superintendent approves the document.
8. *What is the distribution of an approved Scope of Collection Statement?*
- The park or other NPS unit maintains the original approved Scope of Collection Statement. A copy of the approved SOCS should be forwarded to the regional/SO curator.
9. *How often should I review and revise my park's Scope of Collection Statement?*
- Review your park's Scope of Collection Statement at least every five years. Revise it whenever changed conditions clearly alter the mission of your park or when priorities in a specific collecting category have been met. Your superintendent must review and approve any changes made to the SOCS. See Appendix E, for a checklist that you can use to prepare or review your park's Scope of Collection Statement.
10. *What are the parts of a Scope of Collection Statement?*
- Include the following sections in your Scope of Collection Statement:
- Title Page
 - Table of Contents
 - Executive Summary
 - Introduction
 - Types of Collections
 - Museum Collections Subject to the Native American Graves Protection and Repatriation Act (NAGPRA) of 1990
 - Acquisition

- Uses of Collections
- Restrictions
- Management Actions

The Introduction and Types of Collections sections are the most important components of the document. These two sections establish the purpose of the park's museum collection and describe the types of objects that the park will collect. The information in these two sections ensures the collection's logical growth while guarding against the acquisition of objects that are not clearly relevant to the park. See Appendix E, for an example of a Scope of Collection Statement.

11. *What is the Executive Summary (Scope of Collection Summary)?*

The Executive Summary (or Scope of Collection Summary) is one or a few paragraphs that summarize the park's collections and highlight the most significant aspects or individual items. The Executive Summary should be located at the beginning of your Scope of Collection Statement. You also may wish to include this same information in a single stand-alone document that you can distribute to park staff, visitors, the press, and other interested parties. Figure 2.1 includes an example Scope of Collection Summary document. This example is available in electronic format. Contact your regional/SO curator to get an electronic copy to use as a template when preparing your park's Scope of Collection Summary.

12. *When should I use the Scope of Collection Summary?*

Use the Scope of Collection Summary when you need a description of the collection for:

- park planning documents
- entries in directories
- press releases
- web sites
- other publications

You can use the Scope of Collection Summary to update your park's "Collection Summary" on "About Museum Collections" on InsideNPS. Go to <<http://inside.nps.gov/documents/museum>> and follow the instructions under "Edit Park Data."

D. Writing the Introductory Section of the Scope of Collection Statement

1. *What should I include on the Title Page?*

Prepare a title page that spells out the full name of the park (for example, Zion National Park, Fort Clatsop National Memorial). The Title Page also serves as the review and approval page. See Appendix E, for the Scope of Collection Statement Title Page format.

2. *What should I include in the Executive Summary?* Prepare an Executive Summary that consists of one to a few paragraphs that succinctly outlines the park's collections and highlights the most significant aspects or individual items. The Executive Summary is a useful resource for providing concise collections information to park management, planning staff, and others. You may wish to include this same information in a single stand-alone document (or Scope of Collection Summary) that you can distribute to park staff, visitors, the press, and other interested parties (see Figure 2.1). Use the Scope of Collection Summary when you need a description of the collection for park planning documents, entries in directories, press releases, public inquiries, web sites, or publications. The Scope of Collection Summary can also be made available via the web. See Appendix E, for the Scope of Collection Statement Executive Summary format.
3. *What should I include in the Table of Contents?* Prepare a Table of Contents that lists all of the sections and sub-sections of the SOCS with page numbers. See Appendix E, for the Scope of Collection Statement Table of Contents format.
4. *How do I prepare the Introduction?* The Introduction defines the purpose of your park's museum collection. Justify the collection's significance and include pertinent elements from the park's enabling legislation, other mandates, mission statement, and approved park planning documents. When writing your Introduction, you should state the purpose of the park's Scope of Collection Statement. Sample wording for this section is as follows:
- This Scope of Collection Statement defines the scope of present and future museum collection holdings of Lewis Mountains National Park that contribute directly to the understanding and interpretation of the park's purpose, themes, and resources, as well as those objects that the Service is legally mandated to preserve. It is designed to ensure that the museum collection is clearly relevant to the park.*
5. *What legal authorities should I reference?* Reference the legal authorities for the Service to acquire, document, preserve, and provide access to museum collections:
- Antiquities Act of 1906 (16 USC 431-433)
 - Organic Act of 1916 (16 USC 1 et. seq.)
 - Historic Sites Act of 1935 (16 USC 461-467)
 - Management of Museum Properties Act of 1955, as amended (16 USC 18f)
 - Reservoir Salvage Act of 1960, as amended (16 USC 469-469C)
 - National Historic Preservation Act of 1966, as amended (16 USC 470 et seq.)
 - Archeological and Historic Preservation Act of 1974, as amended (16 USC 469-4691-2)
 - Archaeological Resources Protection Act of 1979, as amended (16 USC 470aa-mm)

- National Parks Omnibus Management Act of 1998 (16 USC 5901)

See Appendix A for a summary of these laws.

Sample wording for this section is as follows:

The National Park Service's (NPS) legal mandate for acquiring and preserving museum collections is contained in the Antiquities Act of 1906 (16 USC 431-433); the Organic Act of 1916 (16 USC 1 et. seq.); the Historic Sites Act of 1935 (16 USC 461-467); the Management of Museum Properties Act of 1955, as amended (16 USC 18f); the Reservoir Salvage Act of 1960, as amended (16 USC 469-469c); the National Historic Preservation Act of 1966, as amended (16 USC 470 et seq.); the Archeological and Historic Preservation Act of 1974, as amended (16 USC 469-469l-2); the Archaeological Resources Protection Act of 1979, as amended (16 USC 470aa-mm); the National Parks Omnibus Management Act of 1998 (16 USC 5901).

6. *What information should I include about the park's mission?* State the park's mission. Cite the park's enabling legislation and any relevant subsequent legislation. Include excerpts. If applicable, note that the legislation for the park requires the establishment and maintenance of a museum collection. Be sure to mention any litigation or judgements relating to the collection as well.
7. *What information should I include about the purpose of the collection?* State the purpose of the park's museum collection. A park's museum collection:
 - provides valuable information about processes, events, and interactions among cultures, individuals, and the environment
 - places objects and specimens within a broader context, through research, analysis, and documentary records
 - provides for the greatest benefit and enjoyment by the public
 - provides baseline data, serving as scientific and historical documentation of the Service's resources, and of the purpose for which the park was established
 - may document important events or people in the nation's history, technological processes, or artistic endeavors
8. *What park documents should I reference?* Refer to your park's General Management Plan (GMP) (in lieu of a GMP, refer to the park's current Government Performance Results Act [GPRA] Strategic Plan), Resource Management Plan, Long-Range Interpretive Plan, Historic Furnishings Reports, Historic Structure Reports, exhibit planning documents, or other relevant planning documents in defining the purpose of your park's museum collection.

Study your park's interpretive planning documents, and relate how the museum collection supports the interpretive program. List the interpretive themes and periods. If they exist, cite the park's Long-Range Interpretive Plan and other interpretive plans. Include title(s) and approval date(s).

Study your park's resource management planning documents, and, where relevant, state how the museum collection supports the park's resource management program. List pertinent resource management goals and objectives. If they exist, cite the park's Resource Management Plan, Natural Resources Network Inventory and Monitoring Study Plan, Fire Management Plan, and other resource management plans. Include title(s) and approval date(s).

9. *What should I include about mandated collections?*

Identify mandated collections. The purpose for the park's museum collection also includes managing objects that the Service is mandated to preserve.

43 CFR 7.13, "Custody of Archeological Resources," and NPS *Management Policies* (2001), mandate that archeological collections (including associated records) acquired as a result of systematic investigation within a park's boundary must be managed intact as part of the park's resources and, therefore, never can be outside a park's approved Scope of Collection Statement.

Certain natural history specimens that are not consumed in analysis and are determined to be appropriate for long-term preservation are included in a NPS museum collection in compliance with 36 CFR 2.5, "Research Specimens."

Sample wording for this section is as follows:

Archeological collections, except inalienable and communal property (as defined by the Native American Graves Protection and Repatriation Act of 1990 [25 USC 3001-13]), recovered from within park boundaries through systematic collection are Federal property and must be retained in the park's museum collection in accordance with 43 CFR 7.13 and NPS Management Policies (2001).

In accordance with the NPS Research Permit and Reporting System, permits to collect natural resource specimens state that retained specimens remain Federal property, are incorporated into the park museum collection and, as required by 36 CFR 2.5g, must bear official National Park Service museum labels and their catalog numbers will be registered in the National Park Service National Catalog.

10. *Should I include information on the significance of the collection?*

Yes. Be sure to discuss the significance and history of your park's museum collection. This is an important part of every SOCS, as it:

- details the development of your park's collection
- ensures that important collections history information is not lost due to staff turnover
- documents the significance of the museum collections in text that can also be used in PMIS project justifications and other funding requests

Note: You also may want to include information concerning your park's past curators and managers, as well as past management priorities. Such information may prove helpful as you attempt to develop solutions to

various museum management issues.

11. *What other references should I include in the Introduction?*

List other laws, regulations, directives, and conventions that are pertinent to the acquisition of museum collections. See Appendix A, for a list and summary of these documents. Suggested wording for this section is as follows:

Other laws, regulations, directives and conventions pertinent to the acquisition of museum collections at the park include: the Lacey Act of 1900 (18 USC 43-44); the Migratory Bird Treaty Act of 1918 (16 USC 703-711); the Bald Eagle Protection Act of 1940, as amended (16 USC 668-668d); the Federal Property and Administrative Services Act of 1949, as amended (40 USC 483[b]); the Federal Records Act of 1950, as amended ("Records Management by Federal Agencies" [44 USC 3101 et. seq.]); the Freedom of Information Act of 1966, as amended (5 USC 552); the Marine Mammal Protection Act of 1972 (16 USC 1361-1407); the Endangered Species Act of 1973, as amended (16 USC 1531-1543); the Privacy Act of 1974 (5 USC 552a); the Copyright Act of 1976 (17 USC 101 et seq. [1988 & Supp. V 1993]); the American Indian Religious Freedom Act of 1978 (42 USC 1996); the Native American Graves Protection and Repatriation Act of 1990 (NAGPRA) (25 USC 3001-3013); Federal Property Management Regulations (FPMR), 41 CFR 101; 410 Departmental Manual, Interior Property Management Regulations (IPMR); 411 Departmental Manual, "Managing Museum Property," Chapters 1-3; "Curation of Federally-Owned and Administered Archeological Collections," 36 CFR 79; NAGPRA Final Regulations, 43 CFR 10; "Disposition of Federal Records," 36 CFR 1228; "Protection of Archeological Resources", 43 CFR 7; "Preservation of American Antiquities", 43 CFR 3; "Preservation, Arrangement, Duplication, Exhibition of Records" (44 USC 2109); "Disposal of Records" (44 USC 3301 et seq.); Director's Order #19: Records Management; Director's Order #24: NPS Museum Collections Management; Director's Order #28: Cultural Resource Management; Director's Order #44: Personal Property Management; the 1983 Convention on International Trade in Endangered Species of Wild Fauna and Flora (CITES); the 1970 UNESCO Convention on the Means of Prohibiting and Preventing the Illicit Import, Export, and Transfer of Ownership of Cultural Property (implemented in the United States by P.L. 97-446 in 1983, 19 USC 2601).

Identify any special designations (such as Biosphere Reserve, National Historic Landmark, World Heritage Site) that may be relevant to the park's museum collection. At the same time, be sure to note if the park is part of a larger (but local) heritage area designation or historic preservation district.

Refer to the sample Scope of Collection Statement in Appendix E, for additional help when drafting the Introduction section of your SOCS.

E. Writing the Types of Collections Section

1. *What should I include in the Types of Collections section?*

In the Types of Collections section, identify the specific types of museum collections that your park acquires to meet the purpose(s) stated in the Introduction. Describe what should be collected to meet the park's enabling legislation, any subsequent legislation, and approved resource management

and interpretive goals and objectives, as well as mandates relevant to archeological and natural history collections. You should:

- State that the Introduction defines the purpose of the park's museum collection.
- Note the two major categories of museum collections: Natural History and Cultural Collections.
 - **Natural History Collections.** Your park's natural history collection may include specimens from the disciplines of biology, geology, and paleontology.
 - **Cultural Collections.** Your park's cultural collection may include objects from the disciplines of archeology, ethnography, and history (including archives and manuscripts).
- Subdivide each appropriate discipline into collecting categories that reflect the purposes of the park. Establish the collecting categories based on classification, time period, themes, or other criteria. Examples may include types of biological collections (birds, mammals, and fungi), archeological materials recovered during pre-construction compliance work, archival materials associated with certain individuals related to the park.
- Briefly describe current representation of object types under each collecting category.
 - Discuss strengths of the existing collection.
 - Identify any current deficiencies to help define acquisition priorities.
 - Provide sufficient detail to distinguish the various types of items that may be considered for acquisition.
 - Establish quantitative or qualitative limits on the size of the collection when possible.
- Include all archeological materials and natural history specimens collected within park boundaries that the park is mandated to maintain in park collections.
 - These items are Federal property and must be retained in the museum collection according to law, regulation, and policy.
 - State the requirement to retain all resource management records prepared or assembled as a result of archeological survey, excavation, or other study. State the requirement to retain resource management records generated by natural resource studies that the NPS initiates. When these records are associated with collected artifacts or specimens they are known as associated records. In accordance with NPS *Management Policies* (2001), 4.2.2. Independent Studies, and the NPS Research Permit and Reporting

System, parks may require researchers doing independent (non-NPS) studies to provide the park with copies of field notes, final reports, or other documentation related to the project. If the park has this requirement, include it in the SOCS. See *MH-II*, Appendix D, for information concerning associated records.

2. *What do I need to know about natural history collections to help me prepare the Types of Collections section?*

Parks generate natural history collections in relation to the size and complexity of natural resources within the park, the number of research and monitoring projects, and for multiple uses. Natural history collections contain materials from the disciplines of biology, paleontology, and geology. Your park's collection may include:

- **Reference Collections.** Many living organisms, fossils, and minerals are difficult to identify. Reference collections allow identification by comparison with actual specimens.
- **Synoptic Collections.** Synoptic collections contain multiple representatives of a particular group from the park. They are generated to document presence and distribution, to establish baseline inventories, for monitoring, or to illustrate the morphological variations within a genus or a species.
- **Voucher Collections.** Studies and projects generate voucher specimens that document by date and locality species identity, age classes, genetic variations, and other information that may be reviewed in the future by other investigators.
- **Type Collections.** A type specimen is the specimen used to describe a new species for the first time. The definitions and procedures for type specimens are tightly controlled by international codes (such as the *International Code of Botanical Nomenclature*). Type specimens have extremely high scientific value. They are managed as NPS controlled museum property and must be afforded appropriate storage and security.
- **Tissue Samples.** Viable tissue samples are rare in NPS collections, as the specimens must be stored within specialized equipment that can maintain ultracold (about -80°C) or cryogenic temperatures (below -130°C) for their preservation. The exact temperature is usually determined by the sensitivity of the specimens. -130°C is the maximum temperature for long-term stability of plant and animal cells and -150°C or lower is considered to be optimum for preservation. See *MH-I*, Appendix T, for additional information on tissue samples.

Natural history collections can result from ongoing park projects such as Fire Effects projects, Inventorying and Monitoring projects, Cultural Landscape Reports, Ethnobotanical Studies, and other activities. These collections can also result from research conducted by non-NPS scientists working in the park under permit. Be sure to develop your park's natural history collection in close coordination with your park's Research Coordinator, resource management and interpretive staff, scientists, your regional/SO curator, and Native American and other cultural groups associated with the park.

3. *What other information concerning natural history collections should I include in the Types of Collections section?*

Your discussion of natural history collections should include a brief paragraph that describes a program for the selective acquisition of natural history specimens for the collection. Base this paragraph on appropriate resource management and interpretive goals and objectives of your park. Be sure to state that:

- Specimens must be collected scientifically, so that only well documented and appropriate specimens are retained in the collection.
- No non-NPS collector can work in the park without first obtaining a permit. The permit's "Collections Section" must also be completed, documenting where collections of specimens and associated records will be housed.

Note: You may want to encourage park staff to obtain a permit for projects that they undertake in the park as well. Consult with your park's research coordinator concerning this and other related matters.

Neither the Collections Advisory Committee nor the museum staff decide what research will be conducted in the park. The superintendent, with the input of your park's research coordinator, makes that decision. Both the committee and the museum staff advise the superintendent on what objects and specimens should be (or must be, according to statute) accessioned into the park's museum collection.

In some parks, curatorial and natural resource staff work together to review collection permit requests, advising the superintendent to reject certain requests that are duplicative of existing collections and re-direct the researcher to the existing park collections. This policy is particularly valuable to support park goals of protecting rare species and limiting/preventing duplicative collecting.

Other information that you should mention in this section includes:

- The collecting category "Associated Records" under each discipline. (See *MH-II*, Appendix D: Archival and Manuscript Collections and Question 6. below, "What do I need to know about Archival and Manuscript Collections..." for information concerning associated records.)
- A statement that addresses the park's program to curtail uncontrolled collecting of natural resources by staff and visitors.

Note: Many parks maintain teaching collections of herbarium, mammal, bird, and other specimens. Such collections are usually managed by the park's interpretive division and are typically located in an environmental education center, visitor center "hands-on displays," or are included within a "traveling trunk" used for off-site programs. Such specimens do not result from authorized scientific research in the park, but rather from road kills, collecting outside park boundaries, and illegally possessed flora, fauna, and other specimens seized by state and Federal authorities. Since these

collections are truly interpretive in nature and were not a product of scientific research, do not accession these materials into the museum collection. If your park has such a teaching collection, it is useful to note this fact in the SOCS to differentiate it from the museum collection.

Except for specimens that the Service is mandated to preserve, a natural history collection may not be applicable to your park's enabling legislation, interpretive themes, and resource management goals and objectives. If your park does not currently possess or intend to acquire a natural history collection (other than mandated collections resulting from resource management activities), include a short statement in this section to that effect.

See Appendix E, for an example Scope of Collection Statement that includes sample language and content concerning natural history collections.

4. *What do I need to know about cultural collections to help me prepare the Types of Collections section?*

Your park's cultural collection may contain materials from the disciplines of archeology, ethnology, and history (including, but not limited to, fine and decorative arts, architectural materials, and archival and manuscript collections).

Develop your park's cultural collection in close coordination with park resource management and interpretive staff, your regional/SO curator, historians, archivists, archeologists, ethnographers, and Native Americans and other groups who have a personal or cultural affiliation with the collection.

Limiting the growth of history and ethnographic collections may be an important concern. Consider your park's interpretive and resource management goals and objectives, as well as your capability to properly manage and preserve these collections. If appropriate, indicate the types of objects that should not be part of the collection. History and ethnographic collections may be limited to types and quantities sufficient to implement exhibit planning documents and/or a Historic Furnishings Report.

5. *What other information about cultural collections should I include in the Types of Collections section?*

Your discussion of cultural collections should include:

- An introductory paragraph that indicates the purpose of these collections.
- Information concerning archeology collections:
 - Artifacts and Specimens. Include a statement that addresses the park's program to curtail uncontrolled surface collecting by staff and visitors.

- Associated Records. See *MH-II*, Appendix D: Archival and Manuscript Collections and Question 6. below, “What do I need to know about Archival and Manuscript Collections...” for information concerning associated records.
- Your park’s collection priorities. State that:
 - An object from the site or directly associated with person(s) or event(s) commemorated by the park is more desirable than a similar object without such association.
 - Priority must be given to the best-documented site-related objects. When a large quantity of an object type is available, priority will be given to acquiring the best-preserved examples (unless there is greater value in the assemblage of a whole set rather than simply of individual items).
- A brief listing of those types of object currently in the collection.
- Information concerning history and ethnographic collections.
 - If a history or ethnographic research/study collection is deemed to be important to fulfilling the park’s mission, make such a statement.
 - Justify this collection by referencing appropriate resource management and interpretive goals and objectives.

See Appendix E, for a sample Scope of Collection Statement that includes language and content concerning cultural collections.

6. *What do I need to know about Archival and Manuscript Collections to help me prepare the Types of Collections section?*

Never include official records in the museum collection without specific authorization from the National Archives and Records Administration (NARA). Official records are defined under the Federal Records Act. They are also described in guidelines issued by NARA, and in NPS Director’s Order #19: Records Management. Official records include original or “record copy” documents created or received in the course of performing the daily work of the NPS. Examples of official records include audit records, budget materials, central park correspondence files, contracting files, financial records, law enforcement records, legal records, museum administrative records, permits, personnel records, project files, and similar types of materials. By law, the NARA has authority over these materials, and they must be transferred to that agency or otherwise disposed of according to NARA guidelines.

The museum collection may include several categories of archival and manuscript materials that do not meet the statutory definition of official records, as well as official records that the National Archives has authorized NPS to retain. These materials include:

- **Personal Papers or Organizational Archives** donated to the NPS by non-Federal sources. Because these materials are non-Federal in origin and because the NPS obtained them as museum objects rather than as records of NPS activity, they are not considered to be official records.

Note: Acquiring such collections without also acquiring the copyrights can severely limit the park’s use of the items. NPS acquisition policy requires parks to:

- determine who owns the copyright
- if possible, have the owner transfer the copyrights to the NPS

See Section E: Acquiring Copyrights, in *MH-II*, Chapter 2: Accessioning, for additional information.

- **Sub-Official Records.** These include *copies* of official records, such as bibliographies, desk files maintained by individual NPS employees, park handouts, and other documents kept for purposes of reference or convenience.
- **Resource Management Files.** These records are defined in the Departmental Manual (411 DM 1, Policy and Responsibilities for Managing Museum Property), and include site forms, field notes, drawings, maps, photographs, video tapes, sound recordings, oral histories, inventories of artifacts, laboratory reports, and “Associated Records” that are created in connection with specific sites, objects, and specimens. Although these are official records created by a Federal employee, contractor, or partner, the Service has permission from the NARA to keep them because they relate directly to museum collections and park resources, and because they are critical for the interpretation, management, or preservation of the nation’s natural and cultural heritage. See 36 CFR 79 for additional information concerning associated records related to archeological resources.

Archival documents can be in any format: paper, film, audio or video recordings, or electronic (computer-based) media, to name but a few.

Also, except for materials compiled by NPS staff into “assembled collections,” it is seldom appropriate to acquire or maintain archival materials on a document-by-document basis. Instead, archival materials usually are kept in their original groupings, following the filing schemes developed by the person or organization that created them. Therefore, it is preferable to acquire archival materials on a collection-by-collection basis. See *MH-II*, Appendix D: Museum Archival and Manuscript Collections for additional information.

See *MH-I*, Appendix E, for a sample Scope of Collection Statement that illustrates sample language and content for this collecting category.

7. *How do I determine if material belongs in the park library or the museum collection?*

Library Collections. As a general rule, place publications that are not rare or assembled by an eminent figure related to the park’s mission in the park library. See *Conserve O Gram* 19/1, “What Makes a Book Rare” for the definition of a rare book.

Museum Collections. In addition to the excepted publications noted above, place all original archival documents, whether in audio-visual, electronic, textual, or visual format, in the museum collection. These

original materials include such items as audiotapes, correspondence, graphic prints, manuscripts, motion picture film footage, photographs, reports, and videotapes, plus all other original documentary formats.

Books associated with a significant individual (such as Frederick Douglass) or acquired in response to a deficiency identified in a Historic Furnishings Report or Exhibit Plan should be placed in the museum collection.

F. Writing the Museum Collections Subject to NAGPRA Section

1. *What is NAGPRA?*

The Native American Graves Protection and Repatriation Act of 1990 (NAGPRA) (25 USC Chapter 32) recognizes the rights of lineal descendants, culturally affiliated Indian tribes (including Native Alaskan villages or corporations), or Native Hawaiian organizations to control or own Native American human remains, funerary objects, sacred objects, and objects of cultural patrimony that are held by federal agencies and museums that receive federal funds. In addition to its other provisions, the law requires these agencies and museums to:

- conduct inventories and produce written summaries of such items in their collections
- repatriate (return) identified NAGPRA associated items to the appropriate lineal descendants, culturally affiliated Indian tribes, or Native Hawaiian organizations in compliance with the law, if requested to do so by these groups

For additional information concerning NAGPRA, see Appendix A: Mandates and Standards and *MH-II*, Chapter 6: Deaccessioning.

2. *What do I include in the SOCS about NAGPRA?*

If applicable to your park, include information on the written summary and inventory.

Written Summary. If applicable to your park, state that the NPS met the legal requirement by distribution of the Servicewide Summary, listed by park, to all Indian Tribes, Alaskan Native villages or corporations, and Native Hawaiian organizations on October 27, 1993. In accordance with *Cultural Resource Management Guideline* (1997), Appendix R, NAGPRA Compliance, superintendents must periodically review and update summaries to reflect new acquisitions and newly recognized Indian tribes. State that an updated copy of this summary is on file at your park. If your park has no museum objects in the NAGPRA defined categories of unassociated funerary objects, sacred objects, or objects of cultural patrimony, make a statement to that effect. Suggested wording for this section is as follows:

The Native American Graves Protection and Repatriation Act of 1990 (NAGPRA), 25 USC 3001-13, requires, in addition to other actions, a written summary of unassociated funerary objects, sacred objects, and

objects of cultural patrimony. The park's holdings that fall into these NAGPRA categories are listed in the Servicewide Summary that was distributed to all Indian Tribes, Alaska Native villages, and Native Hawaiian organizations on October 27, 1993. An updated copy of this summary is on file at the park.

Inventory. If applicable, state that your park has human remains or associated funerary objects subject to NAGPRA in its collection. State as of **[note date]** the park completed the inventory of Native American human remains and funerary objects. In accordance with *Cultural Resource Management Guideline* (1997), Appendix R, NAGPRA Compliance, superintendents must periodically review and update the inventory to reflect new acquisitions and newly recognized Indian tribes. State that an updated copy of this inventory is on file at your park. If the park has no human remains or associated funerary objects, make a statement to that effect. Suggested wording for this section is as follows:

NAGPRA requires a written, item-by-item inventory of human remains and associated funerary objects to be completed no later than November 16, 1995. The park has human remains and associated funerary objects subject to NAGPRA in its museum collection. A detailed listing of these items is contained in the park's NAGPRA Inventory, completed [note date]. An updated copy of this inventory is on file at the park.

Note: You must keep all NAGPRA summaries and inventories up-to-date. If your park has acquired NAGPRA related items since 1993, be sure to amend your park's summary and inventory to reflect this. For additional information, see *Cultural Resource Management Guideline*, Appendix R, NAGPRA Compliance, pp. 325-326.

G. Writing the Acquisition Section

1. *How do I prepare the Acquisition section?*

When writing the Acquisition section, be sure to:

- Describe the various types of acquisition sources.
- State that museum objects must be acquired, accessioned, and cataloged in accordance with *Museum Handbook*, Part II, Museum Records.
- State that the acquisition of museum objects is governed by the park's ability to manage, preserve, and provide access to them according to:
 - *NPS Management Policies* (2001), Chapter 5
 - Director's Order #28, Cultural Resource Management (1998)
 - *Cultural Resource Management Guideline* (1997)
 - Director's Order #24: NPS Museum Collections Management (2000)
 - *NPS Museum Handbook*, Part I, Museum Collections, Part II,

Museum Records, and Part III, Access and Use

- State that the park will not be a partner to, or encourage in any way, the trafficking in illicitly collected materials. Be sure that all acquisitions were collected, exported, imported, transported, or otherwise obtained and possessed in full compliance with the laws and regulations of:
 - the country of origin
 - the United States federal government (including NAGPRA)
 - the individual states within the U.S.

See *MH-II*, Chapter 2: Accessioning, Section D. Special Considerations for Accessions, for information on the illicit trade of collections.

- State that the acquisition of firearms included on the Bureau of Alcohol, Tobacco, and Firearms (ATF) list of prohibited/restricted weapons requires concurrent review by the regional/SO curator and the regional/SO law enforcement specialist.
- State that NPS policy requires superintendents to accept only unconditional gifts. This includes acquiring all copyrights at the time of acquisition. Only the regional director has the authority to approve conditional gifts for rare exceptions, on a case-by-case basis. See Director's Order #24: NPS Museum Collections Management (2000), 4.3.15 Unconditional Gifts and *Museum Handbook*, Part II: Museum Records, Chapter 2, Section E. "Acquiring Copyrights."
- Make a statement regarding delegation to the park superintendent of the responsibility for accepting title to museum collections and for their subsequent management. As appropriate, outline any park-specific acquisition procedures that supplement the Servicewide requirements.

2. What is some suggested wording for the Acquisition section?

Suggested wording for the Acquisition section is as follows:

The park acquires objects for its museum collections by gift, purchase, exchange, transfer, field collection, and loan. Museum objects must be acquired, accessioned, and cataloged in accordance with Museum Handbook, Part II, Museum Records. Acquisition of museum objects are governed by the park's ability to manage, preserve, and provide access to them according to NPS Management Policies (2001), Chapter 5; the standards for managing museum objects in Director's Order #28: Cultural Resource Management (1998), Cultural Resource Management Guideline (1997), and Director's Order #24: NPS Museum Collections Management (2000); the NPS Museum Handbook, Part I, Museum Collections and Part III, Access and Use.

In accordance with NPS policy, the park will prohibit the acquisition of gifts with restrictions or limiting conditions. Such restrictions include copyrights; the park will acquire copyrights to all incoming accessions. Incoming loans will be acquired only for a particular purpose such as research or exhibition, and for a specified period of time. Museum objects are acquired, accessioned, and cataloged in accordance with

the NPS Museum Handbook, Part II, Museum Records.

The park will not be a partner to, or encourage in any way, the trafficking in illicitly collected materials. All acquisitions must be collected, exported, imported, transported, or otherwise obtained and possessed in full compliance with the laws and regulations of the country of origin, the United States federal government (including NAGPRA), and the individual states of the United States.

The acquisition of firearms included on the Bureau of Alcohol, Tobacco, and Firearms (ATF) list of prohibited/restricted weapons requires concurrent review by the regional/SO curator and the regional/SO law enforcement specialist.

The park superintendent, by delegation, represents the Director of the National Park Service and the Secretary of the Interior in accepting title to and responsibility for museum objects. The superintendent bears the ultimate responsibility for the acquisition and proper care and management of the museum collection. The superintendent has delegated the day-to-day care of the collection to the museum curator.

All acquisitions must receive formal approval from the superintendent before they can be accepted into the museum collection. Upon receipt, all newly acquired objects and related documentation must be turned over to the museum curator. The museum curator prepares, for the superintendent's signature, all instruments of conveyance, and letters of thanks, acceptance, or rejection, and transmits them as appropriate, to the donor, lender, vendor, or other source of acquisition.

Refer to the Acquisition section of the sample Scope of Collection Statement in Appendix E, for additional help when drafting this section of your SOCS.

H. Writing the Uses of Collections Section

1. *How do I prepare the Uses of Collections section?*

When writing the Uses of Collections section, you should:

- Briefly describe the desired and acceptable uses of the museum collection and establish the limits of such uses. Possible uses include exhibits (including web features), interpretive programs, research, and other interpretive media (such as publications).
- State that the primary consideration in all uses of museum objects is the preservation of each object in question and of the museum collection as a whole.
- If applicable, state that the park may consult with local and/or affiliated Native American tribes, Native Hawaiian organizations, or Alaskan Native villages and corporations about providing access to certain items of concern.
- State that in accordance with *NPS Management Policies (2001)*, Chapters 5 and 7, the park will not exhibit Native American human remains or photographs of those remains. You should also include

language concerning the NPS management policies regarding the display of Native American grave goods or other objects considered sacred. See *NPS Management Policies* (2001), 5.3.4 “Stewardship of Human Remains and Burials,” 5.3.5.5 “Museum Collections,” and 7.5.5 “Consultation.”

- State that any interpretive use defined as consumptive must be authorized in advance, as outlined in Director’s Order #28: Cultural Resources Management (1998) and Director’s Order #6: Interpretation and Education (Draft, 2003).

The NPS prefers the use of reproductions to the consumptive use of original objects.

2. *What is some suggested wording for the Uses of Collections section?*

Suggested wording for Uses of Collections section is as follows:

The park’s museum collection may be used for exhibits, interpretive programs, research, publications, or other interpretive media. The primary considerations for the use of museum objects are the preservation of each object in question and of the collection as a whole, and accurate interpretation.

In accordance with NPS Management Policies (2001), Chapters 5 and 7, the park will not exhibit Native American human remains or photographs of those remains. Drawings, renderings, or casts of such remains will not be displayed without the consent of culturally affiliated Indian tribes and Native Hawaiian organizations. The park will consult with culturally affiliated or traditionally associated peoples to determine the religious status of any object whose sacred nature is suspected but not confirmed. These consultations will occur before such an object is exhibited or any action is taken that may have an adverse effect on its religious qualities.

*Researchers and other specialists may examine objects and archival materials under the conditions and procedures outlined in Director’s Order #24: NPS Museum Collections Management (2000), Director’s Order #28: Cultural Resource Management (1998), Cultural Resource Management Guideline (1997), and in the park’s written “Museum Collections Access Procedures.” Outside researchers must submit a research proposal to the superintendent for review by the park’s Research Committee. If applicable, the research proposal may be presented for review during consultation with the **[list all local and/or affiliated Native American tribes, Native Hawaiian organizations, or Alaskan Native villages and corporations with whom you should consult]** before access to certain items in the collection is granted.*

Any interpretive use defined as consumptive must be authorized in advance, as outlined in Director’s Order #24: NPS Museum Collections Management (2000), Director’s Order #28: Cultural Resource Management (1998), Cultural Resource Management Guideline (1997), and Director’s Order #6: Interpretation and Education (Draft, 2003). The use of reproductions is preferred to the

consumptive use of original objects.

Destructive analysis is a legitimate use of museum collections for approved research purposes when the impact is minor or when the object is common, in which case approval by the superintendent is required. If an object is rare or significant, a request for destructive analysis should be reviewed by the regional/SO curator and may be approved only by the regional director, as outlined in Director's Order #28: Cultural Resource Management (1998) and Cultural Resource Management Guideline (1997).

Objects may be loaned out to qualified institutions for approved purposes in accordance with NPS Museum Handbook, Part II, Chapter 5: Outgoing Loans. Institutions must meet accepted museum standards for security, handling, and exhibition of NPS museum objects. Sensitive materials may require additional conditions prior to a loan commitment. Expenses related to loans of museum objects, including shipping and insurance, will normally be assumed by the borrower.

Refer to the Uses of Collections section of the sample Scope of Collection Statement in Appendix E for additional help when drafting this section of your SOCS.

I. Writing the Restrictions Section

1. *How do I prepare the Restrictions section?*

You should list any restrictions on the museum collection. Restrictions that you should mention include:

- requirements for consultation with culturally affiliated and traditionally associated peoples and other cultural and community groups for whom the collection has significance in accordance with NPS *Management Policies* (2001) 7.5.5 “Consultation” and 5.3.5.5 “Museum Collections,” and DO #24: NPS Museum Collections Management (2000)
- limited public disclosure of sensitive information concerning the following NPS resources in compliance with the National Historic Preservation Act of 1966, as amended (16 USC 470 et seq.), the Archaeological Resources Protection Act of 1979, as amended (16 USC 470aa-mm), the National Parks Omnibus Management Act of 1998 (16 USC 5937) and NPS *Management Policies* (2001) 4.1.2. “Natural Resource Information” and 5.2.3 “Confidentiality”:
 - rare, threatened, or endangered species
 - commercially valuable resources
 - minerals
 - paleontological resources
 - archeological resources

- objects of cultural patrimony and sensitive ethnographic information
- intellectual property rights limitations on publication of archival and manuscript materials, works of art, and other objects (see *MH-III*, Chapter 2: Legal Issues)
- restrictions on the disposition of type specimens
- limited conditions under which endangered, threatened, or rare animals and plants may be collected in accordance with 36 CFR 2.5
- restrictions to ensure an object's preservation
- limited access to certain objects for security purposes
- any limiting conditions placed on objects when they were acquired

2. *What is some suggested wording for the Restrictions section?*

Suggested wording for this section is as follows:

In accordance with NPS Management Policies (2001) 7.5.5. "Consultation" and 5.3.5.5 "Museum Collections," and DO #24: NPS Museum Collections Management, curatorial staff should consult with traditionally associated peoples and other cultural and community groups for whom the collection has significance. Archeological objects in the museum collection shall be made available to persons for use in religious rituals or spiritual activities in accordance with 36 CFR 79, Section 79.10(c), "Curation of Federally-owned and Administered Archeological Collections." Requests to borrow non-archeological material for religious ritual or spiritual activities will be addressed on a case-by-case basis.

The park will not approve research on human remains and associated funerary objects without the consent of the affected group(s).

In accordance with the National Historic Preservation Act of 1966, as amended (16 USC 470 et seq.), the Archaeological Resources Protection Act of 1979, as amended (16 USC 470aa-mm), the National Parks Omnibus Management Act of 1998 (16 USC 5937), and NPS Management Policies (2001) 4.1.2. "Natural Resource Information" and 5.2.3 "Confidentiality," the park may withhold from the public sensitive information concerning: rare, threatened, or endangered species; commercially valuable resources; minerals; paleontological resources; archeological and other cultural resources; objects of cultural patrimony and sensitive ethnographic information; information provided by individuals who wish the information to remain confidential; the identities of individuals who wish to remain anonymous. Inquiries of this nature will be referred to the regional Freedom of Information Act (FOIA) and Privacy Act Officer for consultation and possible review.

Restrictions may be placed on the publication of images or manuscripts in the museum collection if these materials are subject to copyright, and the National Park Service does not hold the copyright.

All endangered, threatened, or rare plants and vertebrate and invertebrate animals will be collected only when accidentally killed or when dead from natural causes. The collection of threatened, endangered, or rare plant and animal species will comply with NPS Management Policies (2001), be in accordance with the provisions of the Endangered Species Act of 1973, as amended, and will be strictly limited according to the applicable rules of the U.S. Fish and Wildlife Service.

Final disposition of type specimens will be determined at the Servicewide level and will adhere to recognized conventions established for specific disciplines.

Refer to the Restrictions section of the sample Scope of Collection Statement in Appendix E for additional help when drafting this section of your SOCS.

J. Writing the Management Actions Section

1. *How do I prepare the Management Actions section?*

When you prepare the Management Actions section, you should:

- State that the park must review the Scope of Collection Statement at least every five years and revise it when necessary, to remain supportive of and consistent with the park's mission.
- Note that appropriate park staff (such as archeologists, interpreters, scientists, naturalists, and other resource management staff) and your regional/SO curator should review any revisions to the Scope of Collection Statement. The superintendent must approve any revision to the SOCS.
- Identify the need for a Collection Management Plan (CMP), if appropriate. Document this need in the park's Resource Management Plan. If this plan has already been prepared, state that fact and give the completion date. See Chapter 3 for information concerning a CMP.
- Identify any park collections that are stored in a repository outside of the park's boundaries (such as a NPS archeological or preservation center, another park, or a non-NPS repository). If this situation exists, list the name of the repository and its location.

2. *What is some suggested wording for the Management Actions section?*

Suggested wording for this section is as follows:

This Scope of Collection Statement must be reviewed every five years, and when necessary, must be revised to remain supportive of and consistent with any changes in the park's mission. Any revision to this document requires the approval of the superintendent.

The park has an approved Collection Management Plan. The plan was approved on [note date].

A number of objects from the collection are housed at repositories

outside of the park [note item type, quantity, institution name, and location].

Refer to the Management Actions section of the sample Scope of Collection Statement in Appendix E for additional help when drafting this section of your SOCS.

K. Implementing the Scope of Collection Statement

1. *Does my park need to develop an acquisition strategy?*

Yes. You should develop an acquisition strategy to fully implement your park's approved Scope of Collection Statement. An acquisition strategy will help you to:

- understand the disciplines and object types represented in the existing collection
- discover gaps in the collection
- identify excess objects not relevant to the scope of your park's collection
- limit acquisitions to only those items identified as mission-related or those deemed necessary to fill pre-determined gaps in the collection

2. *Is there a standard format for an acquisition strategy?*

No, there is no standard format. However, you should consider the following steps in developing an acquisition strategy:

- Assess the types of objects in the museum collection. Include objects, specimens, and archival and manuscript collections on loan to other institutions.
- Identify gaps by comparing the classes of objects identified in the assessment with the types of objects identified in the Scope of Collection Statement.
- Compare objects in the existing collection with object needs identified in an Exhibit Plan or a Historic Furnishings Report. These plans help you to identify objects that are required for the park's interpretive program.
- Develop a prioritized list of items needed for your park's museum collection. One method is to list specific types of collections needed under the disciplines identified in the Scope of Collection Statement. Use the following criteria in prioritizing needs:
 - Acquire objects to replace those borrowed from other parks or institutions.
 - Acquire only those objects that have a strong relationship to the mission of the park and the purpose of the collection as stated in the Scope of Collection Statement. This includes priorities established by an Exhibit Plan or a Historic Furnishings Report.

Note: In order to preserve your collection’s original site-specific objects, you should mention a strategy to acquire “duplicates” (similar objects without site association) or reproductions. You can periodically rotate the “originals” and “duplicates” or reproductions between storage and exhibit to address preservation and security concerns.

- Focus on objects associated with events and activities that took place inside your park’s boundaries.
- Study the park museum files to determine if there are any known sources available to fill identified gaps in the collection. Keep records of potential sources of objects and their locations for future acquisition by the park.

Visitors may express interest in donating or selling museum objects to your park (or they may know of items of interest). See Figure 2.2 for an example Potential Museum Acquisitions sheet that staff can use to record this information. Contact your regional/SO curator to obtain an electronic copy. You also may develop your own park-specific format for recording this information. Provide copies to staff at all visitor contact locations and be sure to train all staff in the purpose, proper use, and disposition of this information sheet.

3. *What other factors should we consider when developing our park’s acquisition strategy?*

Take into account the following issues as well:

Mandated Collections. Include archeological and certain natural history collections in your acquisition strategy. These collections are generated in response to a park’s cultural or scientific resource management requirements and research projects authorized under the Archaeological Resources Protection Act of 1979 (ARPA), 43 CFR 7.13, 36 CFR 2, and the NPS Research Permit and Reporting System. You may not be able to predict the size and scope of these collections, so be sure to work closely with park/center/regional archeologists and scientists to stay informed of the needs, including potential growth, of these collections.

Ability to Manage. Consider any deficiencies (such as the lack of a proper storage facility or inadequate staffing levels) that limit your park’s capability to properly manage additional collections.

4. *What criteria should my park use to acquire collections?*

If the acquisition of an object or objects is justified by your park’s Scope of Collection Statement, you and your superintendent may reserve the right to accept or reject objects on the basis of the following criteria:

- **Site-Specific Objects.** Give first priority to acquiring objects original to a park, as determined by the Scope of Collection Statement, over non-site-specific objects.
- **Objects that are not Site-Specific**

- Consider objects related to the themes or periods of a park, but not original to the site, as your next priority.
- Make decisions concerning the acquisition of non-site-specific objects based on their significance to the park's interpretive and resource management programs. You should also consider such factors as authenticity and their potential for use as comparative collections.
- Reproductions are considered non-site-specific objects.
- **Physical Condition.** In some cases, damage that is the result of historic use or neglect may enhance the intrinsic value of an object (such as the clock from the USS *Arizona* that was damaged in the December 7, 1941 attack on Pearl Harbor). However, a park should consider carefully the acquisition of an object whose integrity has been significantly compromised by deterioration or abuse. In general, the following questions are helpful when evaluating an object:
 - Is the object intact?
 - Are all parts present?
 - Is there evidence of deliberate or accidental damage (such as paint spilled on the object)?
 - Does the object show signs of abuse or neglect (for example, an axe that was used for prying or hammering)?
 - Is the object made of materials that are inherently unstable (such as cellulose nitrate negatives)?
- **Rarity.** If an object is considered rare, it may be advisable for the park to accept a donation regardless of defacement, damage, incompleteness, or the quantity of a class of object already in the collection. **This criterion is particularly important when considering site-specific objects.**
- **Part of a Set.** Individual items that are part of a complete set or assemblage may not be individually important, but when taken together possess importance, and should be acquired as a set.
- **Availability.** Except for objects original to the park, you should take advantage of the availability of proposed donations to augment or replace like objects already in the collection that are in poorer condition or of lower quality.
- **Authenticity.** You need to determine that the object is authentic and that the owner acquired it legally. If you aren't sure about an item's authenticity, consult appropriate subject matter experts (historians, curators, archeologists, scientists, appraisers, and others) or staff at institutions with similar collections.

- **Collections Management Issues.** You must ensure that your park has the proper resources (funding, staffing, facilities, and equipment) to properly manage and preserve the object(s).

5. *Where can I find additional information concerning acquisitions?*

Consult your regional/SO curator and refer to *MH-II*, Chapter 2: Accessioning, Section C: Acquisition Policies, for additional information.

6. *What should I do if the collection includes museum objects that are not relevant to our park?*

Use your park's approved Scope of Collection Statement as the basis for determining what objects in the current collection may not be relevant to the park. Prepare a list of these objects for deaccessioning. See *MH-I*, Part II, Chapter 6, for guidance on deaccessioning museum objects.

L. Selected Bibliography

Alexander, Edward P. "Chapter 7: The Museum as Collection." In *Museums in Motion*, 117-138. Nashville: American Association for State and Local History, 1979.

Edson, Gary and David Dean. "Chapter 5: Collections Management." In *The Handbook for Museums*. London: Routledge, 1997.

Fahy, Anne. *Collections Management*. London: Routledge, 1994.

Genoways, Hugh H. and Lynne M. Ireland. *Museum Administration: An Introduction*. Walnut Creek, CA: AltaMira Press, 2003.

George, Gerald and Cindy Sherrell-Leo. *Starting Right: A Basic Guide to Museum Planning*. Walnut Creek, CA: AltaMira Press, 1986.

Guthe, Carl E. *The Management of Small History Museums*, pp. 21-31. Nashville: American Association for State and Local History, 1982.

Kavanagh, Gaynor. *Museum Provision and Professionalism*. London: Routledge, 1994.

Lee, Welton L., Bruce M. Bell, and John F. Sutton (eds.). *Guidelines for Acquisition and Management of Biological Specimens*. Lawrence, KS: Association of Systematics Collections, 1982.

Lord, Barry and Gail Dexter Lord. *The Manual of Museum Management*. Walnut Creek, CA: AltaMira Press, 1997

Lord, Gail Dexter and Barry Lord (eds.). *The Manual of Museum Planning*. Second Edition. Walnut Creek, CA: AltaMira Press, 2000.



National Park Service
U.S. Department of the Interior

[Park name here]
National Park

[Address Line 1]
[Address Line 1]
(123) 555-1234 phone
(123) 555-2345 fax

[Park Name Here] National Park

Scope of Collection Summary

The museum collection includes both natural history and cultural collections. The natural history collection includes: mammal and bird collections; the park herbarium; paleontological collections from the Bear Valley Shale Formation; geological specimens from the Bear Valley Shale and Lewis Granite Formations. Other natural history collections within the museum collection include: fungi; reptiles and amphibians; fish; insects and arachnids. At present, these collections are relatively small, as little research pertaining to these disciplines has been conducted in the park to date.

The cultural collection includes: archeological materials systematically excavated from within the park's boundaries and associated field records (circa 1000 BCE – circa 1940); an ethnology collection of Paiute and Shoshone basketry, watercolors, beadwork, and textiles; historic objects associated with the area's 19th century miners, railroad workers, and homesteaders, and items related to the Civilian Conservation Corps and President Franklin D. Roosevelt's 1938 park vacation; archival and manuscript collections such as the Joseph Jakes papers, oral histories, photographs, and scientific and resource management records.

For additional information on the museum collection contact:

Museum Curator
[Park Name Here]
[Address Line 1]
[Address Line 2]
(123) 555-1236 phone
(123) 555-2345 fax
[museum email address here]

EXPERIENCE YOUR AMERICA

The National Park Service cares for special places saved by the American people so that all may experience our heritage.

Figure 2.1. Example Scope of Collection Summary



National Park Service
U.S. Department of the Interior

[Park name here]
National Park

[Address Line 1]
[Address Line 1]
(123) 555-1234 phone
(123) 555-2345 fax

[Park Name Here] National Park- Potential Museum Acquisitions

To Park Staff: Use this sheet to note information from visitors concerning collections that the park may wish to acquire. Complete Section A. and forward to the Curator's Office. Use the reverse or attach additional sheets if necessary. **DO NOT ACCEPT ANY ITEMS ON APPROVAL**, only the Superintendent can accept acquisitions for the collection.

A. Basic Information to be Collected by Park Staff

Contact made by: _____
Name Title Division Telephone/Radio Call #

Contact Method: In Person Letter Telephone Email

Contact Date: _____ Check One: Objects Natural History Specimens Archival Materials

Describe the item or collection (discipline(s), quantity, type of item, time periods, condition). Use the reverse if more space is needed: _____

Estimated size of collection (cubic feet, boxes, quantity, as appropriate): _____

Background history of the item/collection: _____

Name, address, telephone number, and email of owner: _____

Current location of collection: _____

Is owner willing to donate, sell, lend, or make the collection available for reproduction and on what terms: _____

B. To be completed by the Collections Advisory Committee

Should Park seek future acquisition of items: Yes No

Native American or other associated group or individual to be consulted: _____

Other Comments: _____

Figure 2.2. Example Potential Museum Acquisitions Sheet

Chapter 3: Preservation: Getting Started

A. Overview	3:1
What is preventive care?.....	3:1
What is conservation treatment?.....	3:3
B. Planning for Object Conservation	3:4
Who is responsible for museum object conservation?	3:4
What are the NPS information resources for conservation?	3:7
What are some other sources for conservation information?	3:8
What do I need to do to develop a preservation program for my park?	3:9
C. The Collection Management Plan	3:10
Why should my park have a CMP?	3:11
What is the process for having a CMP done at my park?.....	3:11
What other kinds of surveys and plans will help me preserve collections?	3:13
D. The Collection Condition Survey	3:13
How do the CCS and the CMP overlap?.....	3:14
What are the steps involved in the survey process?	3:14
What format should the CCS have?	3:16
What is the Condition Field in ANCS+?	3:17
What other information can I add to the ANCS+ collection management program?	3:18
E. Preservation of Historic Structures Housing Park Collections	3:19
F: Glossary	3:20
G: Selected Bibliography	3:22
H. Web Resources	3:22
List of Figures	
Figure 3.1. Different Roles of Curator/Archivist/Collection Manager and Conservator in Object Conservation Management in the Museum	3:6
Figure 3.2. Sample Scope of Work for Requesting a Collection Condition Survey	3:23
Figure 3.3. Sample Project Management Information System (PMIS) Statement for Requesting Conservation Treatment Based on CCS	3:26

CHAPTER 3: PRESERVATION: GETTING STARTED

A. Overview

This chapter will introduce you to one of the main goals of the National Park Service museum program — to preserve museum objects, specimens and archival collections. These collections are natural and cultural resources for our parks. They provide baseline information and are resources for on-going study and use over time. For example, historic objects and archival collections document the lives and history of people and groups throughout the nation. Natural history specimens and their associated documentation record evolving park ecosystems and provide information that helps parks manage natural resources. Archeological collections and their associated documentation record archeological activity and preserve data (artifacts, reports, photographs, maps) for future analysis.

The NPS uses the term **object conservation** to describe the activities that preserve museum collections. The use of the term “object” distinguishes these activities from conservation of the environment. Object conservation activities include examination, documentation, treatment, and preventive care, supported by research and education. You can find definitions of these and other terms in the glossary at the end of this chapter. NPS policies for the treatment of museum objects, excerpted from the NPS *Management Policies*, are in Appendix A.

This chapter will give you information on:

- preventive care and treatment for museum collections
- NPS resources for preventive care
- how to plan for object conservation
- the role of a collection management plan (CMP) in conservation planning
- the role of a collection condition survey (CCS) in conservation planning
- balancing preservation of historic structures and museum objects

We use museum object conservation to preserve objects by minimizing chemical and physical change. In the NPS, object conservation is an ongoing process of **preventive care** supplemented by **conservation treatment**.

1. *What is preventive care?*

The role of preventive care (also known as preventive conservation) is to avoid, block, or minimize the **agents of deterioration**. By using preventive care techniques you can limit the imperceptible deterioration that occurs on a daily basis (but is cumulative over time) and the catastrophic damage that occurs occasionally. Only when preventive care techniques are not implemented or objects are inherently unstable, is conservation treatment necessary.

The agents of deterioration are forces that act upon objects causing chemical and physical damage. The Canadian Conservation Institute has defined the agents of deterioration as:

- **Direct physical forces**, such as shock, vibration, and abrasion that can break, distort, puncture, dent, and scratch all types of objects. These forces may be *cumulative*, such as improper handling or support or *catastrophic*, such as earthquake, war, or shelf collapse.
- **Thieves, vandals, or careless individuals** who misplace objects. Some of these agents are *intentional*, such as criminals who steal or disfigure objects. Others are *unintentional*, such as staff or users who misfile objects.
- **Fire** that destroys, scorches, or deposits smoke on all types of objects.
- **Water** that causes efflorescence in porous materials, swells organic materials, corrodes metals, delaminates and/or buckles layered components, and loosens joined components.
- **Pests**, such as *insects* that consume, perforate, cut, graze, tunnel and/or excrete which destroys, weakens, disfigures, or etches organic materials. Pests also include *vermin* such as birds and other animals that gnaw organic materials and displace small objects, foul objects with feces and urine and *mold and microbes* that weaken or stain objects.
- **Contaminants** that disintegrate, discolor, or corrode all types of objects, especially reactive and porous materials. This includes *gases* (such as pollution, oxygen), *liquids* (such as plasticizers, grease), and *solids* (such as dust, salt).
- **Radiation**, including both ultraviolet radiation and visible light. *Ultraviolet* radiation disintegrates, fades, darkens, and/or yellows the outer layer of organic materials and some colored inorganic materials. *Unnecessary visible light* fades or darkens the outer layer of paints and wood.
- **Incorrect temperature** that can be *too high* causing gradual disintegration or discoloration of organic materials; *too low* causing embrittlement, which results in fractures of paints and other polymers; or *fluctuating* causing fractures and delamination in brittle, solid materials. Fluctuations in temperature also cause fluctuations in RH.
- **Incorrect relative humidity** that can be *damp (over 65% RH)*, causing mold and corrosion, or *above or below a critical value*, hydrating or dehydrating some minerals and corroding metals that contain salts. Organic materials will gradually disintegrate and discolor, especially materials that are chemically unstable at any RH level *above 0%*. *Fluctuating* RH will shrink and swell unconstrained organic materials, crush or fracture constrained organic materials, cause layered organic materials to delaminate and/or buckle, and loosen joints in organic components.

Most objects are affected by a variety of these agents of deterioration at the same time. As you improve preventive care of your collections, you will be addressing each of the agents of deterioration through a variety of policies and procedures. Later chapters will address how you do this.

The park curator has primary responsibility for preventive care of the museum collections. Preventive care requires vigilance by park curators to ensure that damage does not occur. This handbook contains the information you will need to protect your collection by developing a variety of park procedures and programs for preventive care. In order to carry out a proper preventive care program you should:

- know the causes and recognize the symptoms of object deterioration
- inspect collections on a regular basis
- monitor and control the museum environment (relative humidity, temperature, light, pests, dust, and other pollutants)
- practice proper techniques for the handling, storage, exhibit, packing, and shipping of objects
- provide appropriate security and fire protection for collections
- prepare and be able to implement emergency management plans for collections

This introductory chapter will describe how to identify your preventive conservation needs and develop a strong program with a Collection Management Plan (CMP). It will also tell you how to plan for object conservation treatment, using Collection Condition Surveys (CCS) when preventive care is not enough.

2. *What is conservation treatment?*

Conservation treatment is the deliberate alteration of the chemical and/or physical aspects of an item from a museum collection, in order to prolong the item's existence. Treatment may consist of stabilization and/or restoration. **Stabilization** consists of those treatment procedures applied to maintain the integrity of a museum object and to minimize further deterioration. For example, when a conservator washes paper, the washing removes acidic by-products of deterioration. This is a method of stabilization. **Restoration** consists of those treatment procedures intended to return cultural property to a known or assumed state, often through the addition of non-original material. For example, to restore a broken ceramic pot a conservator might glue broken pieces together and fill the losses with plaster.

You should consider conservation treatment in the following cases:

- when preventive care measures are not enough to reduce the rate of deterioration to a tolerable level, such as deteriorating plastic objects
- when deterioration has proceeded to a point where the object is extremely fragile and is in danger in any circumstances, such as when paint is flaking from a picture

- when stabilization or restoration is required for exhibit
- when stabilization or restoration is required for research

Work with your regional/support office (SO) curator to decide whether conservation treatment is required. In the National Park Service, following NPS Management Policies, we keep conservation treatment to a minimum. This approach reduces the chances of compromising the aesthetic, archeological, cultural, historical, physical, religious, or scientific integrity of objects. We emphasize preserving original materials and minimizing restoration.

Any person who performs conservation treatments for the NPS must agree to adhere to the American Institute for Conservation of Historic and Artistic Works (AIC) Code of Ethics and Guidelines for Practice. A copy of this Code of Ethics is included in Appendix D. You should include this requirement in all requests for proposals (RFQs) or contracts with conservators.

B. Planning for Object Conservation

1. *Who is responsible for museum object conservation?*

Preventive conservation is the responsibility of everyone who works in and around museum collections, including archivists, museum technicians, collection managers, conservators, curators, interpreters, maintenance personnel, preparators, and researchers.

The **collection management specialist (curator, archivist, collection manager)** is the person with primary responsibility for the day-to-day management of the museum collection. The duties of these professionals include:

- acquisition
- documentation
- preventive care (preventive conservation)
- interpretation and exhibits
- research and publication

A curator has expertise in material culture studies and is trained and skilled in the history and philosophy of museums, as well as the practical aspects of preventive conservation.

The **conservator** is trained and skilled in the theoretical and practical aspects of preventive conservation and conservation treatment. Most conservators specialize in the treatment of specific groups of objects (for example, archeological objects, books, ethnographic objects, natural science specimens, fine and decorative art objects, photographic materials, paintings, paper, sculpture, textiles, or wooden artifacts). There is some

overlap among these groups, so one conservator may work on a range of these materials.

The collection management specialist (such as a curator, archivist or collections manager) and the conservator work together and with other professionals to develop a successful conservation program. Conservators are responsible for recommending and carrying out conservation treatments. Untrained staff should **NOT** attempt to do treatments. However, the collection management specialist has the ultimate responsibility for deciding on the care and management of the collections.

The roles of the collection management specialist and the conservator in object conservation management are illustrated in Figure 3.1.

Scientific collections (such as natural science and archeological collections) recovered in the field are often prepared by the collector who has expertise in an academic discipline (paleontology, mammology, archeology). Many techniques are used to uncover, clean, sample, identify, stabilize, and preserve materials so they can be used for research and exhibit. For example, most reptiles and fish are prepared by stabilizing specimens in formaldehyde and storing them in alcohol in the field, so that decomposition does not occur. Archeological collections are usually washed and sometimes treated with other chemicals to remove deposits from burial so surfaces can be examined. Within the museum, individuals called preparators, often continue to work on collections— most notably with paleontological and biological collections. Many preparators also are directly responsible for collections care.

All preparation techniques used before accessioning an object, and later in the museum, directly affect the long-term preservation of the specimen or object. There are also many health and safety concerns that occur because of preparation techniques. The curator/collections manager and the conservator must work with others who prepare objects and specimens so that from the time they are collected, thoughtful choices are made that help to preserve them for the long-term. (See the *Conserve O Gram* series for information on many of these concerns.)

<i>Preventive Care</i>	
<i>Curator/Archivist/Collections Manager</i>	<i>Conservator</i>
<ul style="list-style-type: none"> • Monitors and assesses condition of collections • Monitors and evaluates museum environment and alerts staff to signs and causes of deterioration • Practices proper methods and techniques for storing, exhibiting, handling, packing and shipping of objects, and pest management • Develops and implements ongoing Integrated Pest Management (IPM), and housekeeping/maintenance program for collections • Prepares emergency operation plan for museum collections 	<ul style="list-style-type: none"> • Assesses condition of objects; conducts Collection Condition Surveys • Alerts staff to signs and causes of deterioration • Provides technical guidance on museum environment, storage, exhibits, handling, packing and shipping, pest management • Assists in development of Integrated Pest Management (IPM) and housekeeping/maintenance programs • Assists in development and preparation of emergency operation plans
<i>Conservation Treatment</i>	
<i>Curator/Archivist/Collections Manager</i>	<i>Conservator</i>
<ul style="list-style-type: none"> • Documents history, significance, value, and proposed use of each object to be treated • Develops and monitors contracts for conservation services • Assesses, in consultation with conservator, the suitability of written treatment proposals and authorizes treatments • Monitors progress of treatment for each object • Ensures continuing care for treated objects 	<ul style="list-style-type: none"> • Examines and documents conditions and problems of objects and collections • Prepares treatment proposals for curatorial review and approval • Performs suitable treatments • Documents treatments performed • Recommends methods for the future maintenance and care of treated objects • Performs analysis for research and interpretation

Figure 3.1. Different Roles of Curator/Archivist/Collection Manager and Conservator in Object Conservation Management in the Museum

2. *What are the NPS information resources for conservation?*

There are a number of information resources you can refer to when developing your knowledge of conservation and preventive care:

- *NPS Museum Handbook*, Part I (*MH-I*) has a wide variety of information on all the essential parts of your preventive conservation program. Review the chapters in this handbook for information on techniques for setting up your preventive maintenance programs, including security and fire protection, pest management, emergency planning, environmental monitoring, storage, and handling, packing and shipping. It also includes appendices with specific information on the preventive care of the variety of materials you will have to care for in your collection, such as archeological or natural history objects, metals, ceramics, and glass.
- *Conserve O Gram (COG)* leaflets are short technical leaflets on specific topics in collection care and planning, published by the Museum Management Program (MMP). These leaflets are intended to expand and update the information contained in the *MH-I*. These leaflets cover a wide range of subjects including:
 - agents of deterioration
 - archeological objects
 - archival and manuscript collections and rare books
 - ceramics, glass, and plaster objects
 - ethnographic objects
 - furniture and wooden objects
 - leather and skin objects
 - metal, and organic and metal objects
 - natural history specimens
 - museum collection preservation
 - museum collection storage
 - museum exhibits
 - paintings
 - packing and shipping museum objects
 - paper objects
 - photographs

- security, fire, and curatorial safety
- stone objects
- textile objects

The MMP provides all parks with copies of *COG* leaflets. They are also available on the web at:

<<http://www.cr.nps.gov/csd/publications/index.htm>>.

- *NPS Tools of the Trade*, published by the MMP, is a catalog of curatorial supplies and equipment. It includes museum record keeping materials and forms, storage containers, specialty curatorial items (white cotton and latex gloves, polyethylene drawer liners), natural history supplies, museum cabinetry, shelving and racks, and environmental monitoring and control apparatus. *Tools of the Trade* can also give you instructions on how to obtain museum supplies and equipment, get answers to questions about storage techniques, meet special storage requirements, properly use materials and equipment, and find source information for purchasing supplies or equipment. The MMP updates this catalog periodically. Copies have been distributed to all regional offices, parks, and centers. If you don't have this publication, contact the MMP. Keep this catalog handy for reference.
- ANCS+ is the collection management documentation system provided to all parks for cataloging and other documentation purposes. This program contains associated modules and supplemental records that will allow you to incorporate information provided by a conservator. This information includes condition description, and treatment reports and maintenance recommendations. The conservation module (to be released in 2000) helps parks and conservators efficiently incorporate survey, treatment, and analysis information into object documentation.
- There are several conservation laboratories in the NPS that work on museum objects beyond individual parks. Conservators from these labs can assist with surveys, carry out treatments and give you other advice about conservation and conservation contracting. The current labs are at:
 - Harpers Ferry Center, Harpers Ferry, West Virginia
 - Northeast Cultural Resources Center, Lowell, Massachusetts
 - Western Archeological and Conservation Center, Tucson, Arizona

3. *What are some other sources for conservation information?*

There are a wide variety of resources for information on conservation outside the NPS. To start, review the resources listed in the bibliography and web sources.

The American Institute for Conservation of Historic and Artistic Works (AIC) administers the *Guide to Conservation Services*. This free database service can provide you with the names of conservators in your region who have the expertise you need for your project. For information contact AIC at (202) 452-9545 or InfoAIC@aol.com.

There are a number of regional conservation laboratories that can help you. To locate the closest regional lab contact the MMP at (202) 343-8142 or your regional/support office (SO) curator.

4. *What do I need to do to develop a preservation program for my park?*

There are a variety of actions to take in planning and carrying out your preservation program.

Remember: *Museum preservation is an ongoing process, not a one-time effort.*

When you have a well-planned program, you use staff time and funding more efficiently. Your program should include the following actions:

- Document the collection as required by the NPS *Museum Handbook*, Part II: Museum Records (*MH-II*).
- Conduct a self-evaluation to identify deficiencies using the NPS Checklist for Preservation and Protection of Museum Collections (see Appendix F). Use the Automated Checklist Program (ACP), one of the utilities in ANCS+, to fill out and submit your Checklist. You must keep the Checklist up-to-date. The Checklist is also used for Government Performance and Results Act (GPRA) reporting requirements. Use reports from the ACP to provide the “number of standards met” and the “percentage of standards met” to report accomplishments under GPRA. To get more information about the ACP, see the *ANCS+ User Manual*, Appendix G: The Automated Checklist Program.
- Implement a program of preventive care. Start your program by correcting deficiencies in the ACP and developing programming documents to implement recommendations in a Collection Management Plan (CMP) and other surveys. As you correct each deficiency, you will develop your preventive care program. The parts of a program will include:
 - monitoring and controlling the museum environment
 - using proper techniques for the handling, storage, exhibit, and packing and shipping of objects
 - providing security and fire protection
 - planning for emergency operations
 - inspecting objects on a regular basis
 - applying for conservation treatment when necessary
- Complete a Collection Management Plan (CMP) to assess your park’s collection management program and to provide specific guidance on improving the care of the collections. Refer to Section C for additional information on the CMP.

- Complete a Collection Condition Survey (CCS) of the collection after examining the objects and assessing condition and treatment needs. Based on this report and available information regarding use and significance of each object, develop a prioritized object conservation treatment list. Refer to Section D for additional information on the CCS.
- If you have a historic structure housing museum objects, assess the condition and preservation needs of the structure. You need to ensure that the actions you take to preserve the museum objects don't harm the historic structure. You should follow the principles outlined in the New Orleans Charter for Joint Preservation of Historic Structures and Artifacts. You can find the Charter on the web at <http://palimpsest.stanford.edu/bytopic/ethics/neworlea.html>. See Section E for more discussion about preservation of collections in historic structures.
- Prepare budget documents to improve and maintain the object conservation program. You can find information on programming and budgeting in Chapter 12: Programming, Funding, and Staffing.
- Develop and implement training sessions or obtain external training for park staff who handle and work with museum objects.

The rest of this chapter will describe how to complete the Collection Management Plan (CMP) and Collection Condition Survey (CCS). Use the CMP and the CCS as planning documents to help you establish and implement a long-term, ongoing program for the preventive care and treatment of your collection. These documents will help you budget time, funds, and staff to address preservation needs. These plans, however, will only be useful if you are committed to implementing the recommended actions.

C. The Collection Management Plan

A Collection Management Plan (CMP) is a review of your park's collection management program to identify problems and make recommendations on the management and care of the collections. To prepare the plan, use consultants from outside the park that have expertise in a variety of areas. They can advise you on how to improve your program efficiently and effectively. A Collection Management Plan will give you advice on issues such as your:

Scope of Collection statement (SOCS)

- museum records and documentation
- preventive care issues, including environmental conditions, storage, fire and security protection, and emergency management
- collections accessibility and use

- staffing and funding needs
- archival and manuscript collections
- access and use

Refer to Appendix F for an example outline of a CMP.

1. *Why should my park have a CMP?*

A CMP gives you a set of guidelines and recommendations for improving the collection management at your park. You will use it as a prioritized planning document, to plan tasks and to identify long-range curatorial staffing needs. By using the CMP you will be able to develop a series of projects that will allow you to:

- document your collections
- care for them in a way that will best preserve them
- make them available for use

A CMP is a framework that will help you organize the variety of tasks that you are responsible for as the park curator.

2. *What is the process for having a CMP done at my park?*

Follow these steps to get a CMP done.

Request the plan.

Include a project statement in the park Resource Management Plan (RMP) and in the NPS Project Management Information System (PMIS). You can consult the regional/SO curator for assistance in requesting a CMP. Prepare and submit a project statement to PMIS. Refer to Chapter 12 for guidance on programming and budgeting for museum collection management.

Select a planning team.

To ensure objectivity and diversity of views, select a team of NPS or contract museum professionals with expertise appropriate to the nature and needs of the park's collections. The team is generally made up of curators or collections managers and can also include archivists and conservators. The regional/SO curator often assists with the plan. The CMP team will visit your park and collect information from park staff, the regional/SO curator, and other regional specialists, as appropriate.

Prepare and review the plan.

Assign a team coordinator from outside the park. This coordinator will have a variety of duties including:

- coordinating selection of team members and planning the site visit
- coordinating pre-visit activities, such as preparing a pre-visit questionnaire for park staff and collecting previous planning documents
- coordinating on-site activity to ensure that the team collects adequate and appropriate information

- preparing a brief summary of findings for the close-out meeting
- as requested, writing a trip report for the region and park that outlines some of the basic findings and recommendations, including those that should be implemented prior to the completion of the CMP
- reviewing and editing the draft plan and forwarding it to the park for review and approval

The duties for each team member include:

- reviewing all relevant park documents
- participating in the site visit
- evaluating collections, facilities, park procedures and record keeping
- writing assigned CMP sections and submitting them to the team coordinator by the deadline
- revising sections as necessary based on comments

The team submits a review draft of the CMP to the park and region. They may also submit a draft to the MMP and other WASO offices as appropriate. A second draft is prepared incorporating comments. The Superintendent approves the plan upon recommendation by the regional/SO curator and concurrence of the Regional Deputy Director.

Distribute the final plan.

Distribute your CMP to all offices and repositories listed in Director's Order #28: Cultural Resources Management Guideline, Appendix D: Distribution/Availability of Final Cultural Resource Reports. There may be other offices that are also designated by your park or region for distribution.

Note: Sensitive information, such as security systems and the location of museum collection storage facilities, is restricted information and not released to all offices.

Implement the plan.

The plan will list a variety of tasks that will take time, and often money, to carry out. Use these tasks to develop a series of goals that you can strive to accomplish. You will finish some tasks quickly; others require long-term planning and effort. You should review the plan regularly to be sure you are completing necessary actions. It may be necessary to update the plan as your situation changes; for example, as you add new collections or build new facilities. You should consult with your regional/SO curator about options for updating your plan.

3. *What other kinds of surveys and plans will help me preserve collections?*

There are several other planning tools that you may find useful. Each of these surveys focuses on one aspect of **preventive care** and can give you more in-depth information. Some of these reviews are requirements on the Checklist for Preservation and Protection of Museum Collections. These documents include:

- security survey, which helps you plan for appropriate security systems (Checklist question H.2). See Chapter 9: Security and Fire Protection.
- fire protection survey, leading to a structural fire management plan (Checklist question H.3). See Chapter 9: Security and Fire Protection.
- storage survey, leading to a Collection Storage Plan (CSP) (Checklist question H.7). See Chapter 7: Museum Collections Storage.
- archival survey, to identify official and non-official records, provide a collection level description of materials, develop a draft processing plan, review legal issues, identify preventive care issues for the archival and manuscript collections, and provide planning advice for future work. See *MH-II*, Appendix D: Archives and Manuscript Collections.
- general condition surveys, to evaluate the overall condition of collections and make recommendations about how to improve preventive conservation practices. This survey may be part of a CMP or a stand-alone document.
- written recommendations by a professional, for improving the museum environment (temperature, relative humidity and light) based on ongoing park environmental monitoring (Checklist question H.1). See Chapter 4: Museum Collections Environment.
- The Collection Condition Survey (CCS) **identifies condition and treatment needs** and may include preventive care recommendations (Checklist question H.6.).

D. The Collection Condition Survey

A Collection Condition Survey (CCS) is a report on the status of the condition of individual or groups of like items in a park's museum collection. Conservators specialize in different types of materials, so you should select a conservator who has the right expertise for the segment of your collection to be surveyed. For example, you can request that a conservator do a survey of your historic photographs to determine treatment needs and record baseline data for future assessment of deterioration. You might ask another conservator to examine your visitor center to evaluate the objects on exhibit for signs of deterioration and to evaluate the mounts, lighting, case design, and construction. The survey report may also include recommendations about preventive care needs, such as storage techniques, environmental conditions, and pest control.

Over a period of time, you may need several different surveys by conservators who specialize in different types of materials. Your needs will depend on the size and type of your collections and your park programs and priorities.

<p><i>You must use a qualified conservator to do a Collection Condition Survey.</i></p>
--

If you are contracting with a conservator from outside the NPS, get recommendations and descriptions of previous work to be sure the individual is qualified.

1. *How do the CCS and the CMP overlap?*

You should request a CCS only after you have a CMP. Conservation treatment is not appropriate when collections are not documented and basic preventive care programs are not in place. The CMP and the CCS can both contain information on preventive care. Preventive care must be taken into account when carrying out all of your duties with the museum collections. Recommendations on preventive care included in a CMP usually focus on general conditions in exhibit and storage areas and curatorial specialists other than conservators may make these recommendations. The preventive care recommendations in a CCS will advise you how to stop the deterioration seen in the item-by-item survey.

2. *What are the steps involved in the survey process?*

Request the survey.

If you would like to request a CCS, consult the regional/SO curator for assistance. Refer to Chapter 12 for guidance on programming and budgeting. Be sure to include the need for a conservation survey in the park's RMP and in PMIS. See Section C.2.

Select the conservator(s).

A NPS or contract conservator or team of conservators will visit your park to make observations and collect information that goes into the CCS. The size of the team depends on the types of materials to be examined at one time. Conservators conducting a CCS must be specialists in the treatment of the specific class of objects they are examining (for example, furniture, textiles, metals, archeological objects, paper, books, paintings, ethnographic objects, or natural history specimens).

You should be sure that the conservator you select has appropriate knowledge and experience to evaluate your collection. Gather information to be sure you get a conservator with appropriate expertise.

Ask the following questions:

- What kind of training do you have? Conservators get training both through academic departments and internships. They should be willing to describe to you how their training is appropriate to your park's needs.
- How long have you been a conservator? You want to work with conservators who have finished their training and worked professionally for at least three years.
- Is your business mostly conservation?
- Have you worked on this type of material/done this kind of survey before?
- What museum conservation organizations do you belong to?
- Are you available when I need you?
- Can you give me references and contacts with previous clients?

- Do you agree to follow the AIC Code of Ethics and Guidelines for Practice?

You are looking for a knowledgeable, experienced conservator who has worked on the type of material that you have in your collection. If a conservator agrees to follow the AIC Code of Ethics and Guidelines they are agreeing to follow current and generally accepted standards and practices of the conservation profession.

See Figure 3.2 for an example Scope of Work (SOW).

Conduct the survey.

The conservator will need to work directly in your collection storage area in order to see both the objects and the conditions in which they are stored. Each conservator will conduct the survey a little differently, but some responsibilities you should expect include providing:

- a staff member to work with the conservator to:
 - access collection storage rooms, vaults, cabinets, shelves, and other locations where objects are stored
 - assist in moving heavy or unwieldy objects
 - answer questions about environmental monitoring, IPM programs, preventive maintenance, collection use, plans for future acquisition and deaccessioning and other information as necessary
- a suitable workplace near the objects
- catalog, accession, and previous conservation (treatment and survey) records when required
- access to ANCS+

This would be required if the SOW requires information from the survey to be input directly into catalog records. ANCS+ is also a convenient way to provide access to catalog, accession, and conservation records that are available in the database.

Prepare and review the CCS report.

At the start of the project, agree when a draft report will be available for review. One month is usually a reasonable amount of time to produce a draft report. Review the draft carefully and request additional information and clarification where necessary. The conservator should be able to finalize the report within another month, after all NPS reviews are finished.

Distribute the report.

Distribute the CCS to the park and the regional/SO curator and to others designated by the park and region.

Implement the Collection Condition Survey report.

The CCS report documents the condition of the objects that the conservator examined, identifies treatment needs, and sets priorities for treatment based

solely on physical condition and risk. You must evaluate this information in terms of curatorial priorities, such as significance, interpretive programs, and research needs in deciding which objects to treat. Balancing preservation with access and use allows you to develop a program for conservation treatment.

Park curatorial staff should implement the preventive care recommendations in a CCS. You will need to hire a conservator to provide treatments.

Add CCS data on individual objects to collection records.

Section D.5 discusses how you can incorporate this information into ANCS+ records. Adding this information to ANCS+ ensures that it will be maintained with other information about the object for the long-term.

3. *What format should the CCS have?*

CCS reports will vary in the information they provide. Because they may give general preventive care recommendations in addition to item-by-item condition assessments, the structure will reflect the information they contain. The CCS **must** include the following information:

- **Introduction:** The report should contain a narrative introduction that gives general information about the park visit (for example, park name, dates, name of conservator(s), and explanations of all technical terms).
- **General recommendations:** If appropriate, the report will include general recommendations and preventive care tasks.
- **Item-by-item assessments:** Individual object assessments may be either in narrative or checklist format. However, they must include information to complete the Condition field on the catalog record. See a description of this field below.
- **The report should incorporate draft language that can be incorporated into Resources Management Plan (RMP) and/or Performance Management Information System (PMIS) statements.** See Figure 3.3 for examples. For additional examples, see *Project Statements for Museum Collections* prepared by the Museum Services Division, Southeast Regional Office, January 1994. This document was supplied to all parks. It is also available on disk from most regional/SO curators.

The conservation module in ANCS+ (to be released in 2000) allows you to incorporate the information on condition and maintenance collected in conservation surveys directly into ANCS+ collection management records. Guidance on using the Conservation Module is provided in the *ANCS+ User Manual*. You can also incorporate information from CCS reports manually in ANCS+.

4. *What is the Condition Field in ANCS+?*

As part of the condition assessment of the CCS ask the conservator to supply you with the standard NPS abbreviation for the Condition field on the Collection Record for each item examined. Incorporating this information into your catalog records will help parks, centers, and the Museum Management Program make more accurate estimates of the condition of all park collections. It also allows you to track change in condition over time.

For objects, use one term from each of the two criteria groups below:

Group I		Abbreviation
Complete:	100% of object present	COM
Incomplete:	more than 50% and less than 100% of object present	INC
Fragment:	less than or equal to 50% of object present	FRG
Group II		
The following descriptions are for the object in hand regardless of whether it is complete, incomplete, or fragmentary. Note that an object can be incomplete, yet still be in excellent or good condition.		
		Abbreviation
Excellent:	No damage or deterioration. No treatment needed; no change will occur with good preventive conservation practices in place (for example, a pristine porcelain plate).	EX
Good:	Minor damage and no active deterioration. No change will occur with good preventive conservation practices. Minor cosmetic treatment may be needed before exhibit (for example, many historic objects that have been used.)	GD
Fair:	Some damage and/or slow but active deterioration. Treatment may be needed to stabilize or before object is displayed (for example, a decorative ceramic object with losses to the rim, or slowly rusting iron objects).	FR
Poor:	Significant damage and/or active deterioration. Treatment is needed to prevent additional damage or deterioration (for example, a table with one leg missing, making it structurally unstable or an archeological copper alloy object with "bronze disease").	PR

Entries are made using a slash between each term, such as INC/FR.

Examples:

- An unbroken drinking glass with no surface deterioration and no deposits would be COM/EX.
- A single archeological painted ceramic sherd that had been abraded during burial would be FRG/GD.
- A chest of drawers with lifting and lost veneer would be INC/FR.
- A leather saddle with red rot would be COM/PR.

5. *What other information can I add to the ANCS+ collection management program?*

The Conservation Module of ANCS+ (to be released in 2000) provides a way for parks to easily extract data from NPS and contract conservators' condition assessments and include that data in the collection management records. Instructions for using the Conservation Module are included in the *ANCS+ User Manual*. Until this module is released there is still some information that can be included in catalog records. You can request that conservators input this data (which may add cost to the

contract), provide it in a format that can be transferred electronically, or input it into records yourself.

Condition description: Depending on the style of survey the conservator does you may be able to transfer condition description information to the Condition Description (Cons Desc) field on the catalog record. So me surveyors will use a narrative form that will be simple to cut and paste into the field. Other conservators will use a checklist form. If you want to be able to transfer information, be sure to incorporate it as a requirement in your SOW and contract. When the Conservation Module is released, this information can be incorporated automatically.

Preservation Supplemental Record: You can use the Preservation supplemental record in ANCS+ to record a treatment priority from the surveyor. For information see the NPS *ANCS+ User Manual*, Chapter 3: Supplemental Records, XIV Preservation Supplemental. You can record that the object was surveyed by using S for "Surveyed/Not Treated" in the Treatment By field. You can also record any treatment priority that the conservator supplies in the Priority field. When the Conservation Module is released, this information can be incorporated automatically.

Maintenance Associated Module: You can use this module to record regular maintenance that is recommended by the surveyor. This module will help you develop schedules for carrying out and documenting maintenance treatments. For example, if a conservator recommends monthly vacuuming of all upholstered furniture on display, you should record it here. For information see the NPS *ANCS+ User Manual*, Chapter 4: Associated Modules, VI Maintenance Associated Module. When the Conservation Module is released, this information can be incorporated automatically.

E. Preservation of Historic Structures Housing Park Collections

Your museum collections may be housed in a park structure that has great historic significance of its own. Historic structures have their own preservation needs. These needs may be different from the needs of the museum objects. For example, the environment that best preserves museum objects often differs from the best environment to preserve the fabric or envelope of the structure. While managing museum objects, you should keep in mind the nature and significance of the historic structure, too.

There are a number of examples to illustrate how using a historic structure to house museum objects may cause more wear on the structure than its original use:

- Installation of museum exhibits or storage areas may impose loads or require physical design changes to the structure in conflict with its original design and historic integrity.
- Controlling relative humidity levels to strict object standards may cause serious damage to the structure because of condensation within walls.
- Installation and operation of modern mechanical, electrical, plumbing, security, and fire detection and suppression systems may require changes that impact both the historic and structural integrity of the structure.

If you plan to alter a historic structure to improve the care of your collections, you should seek the assistance of other curators, conservators, historical architects, and preservation engineers. Consider the following factors simultaneously in your decision-making process:

- the nature, condition, and preservation needs of the museum collection
- the nature, condition, and preservation needs of the structure housing the museum collection
- the effects of the planned use (for example, interpretive programs) on the structure and the museum collections

The concerns for preserving artifacts and historic structures that house them have led to the development of a set of principles that have been published as the New Orleans Charter for Joint Preservation of Historic Structures and Artifacts. You can view the charter on the web at <http://palimpsest.stanford.edu/bytopic/ethics/neworlea.html>. Use these principles when developing your own preventive care projects for museum collections in historic structures in your park.

You must have a Historic Structure Report (HSR) completed prior to a major intervention (for example, environmental control system, intrusion detection system, fire detection/suppression system). Additionally, any

project, activity, or program that can result in changes in the character or use of historic properties that meet National Register criteria are subject to Section 106 review (36 CFR 800). Consult with your park or regional/SO office historical architect and refer to D.O. #28: Cultural Resource Management Guideline for guidance.

F. Glossary

Agents of deterioration – those agents that act upon museum artifacts to cause physical and/or chemical changes that limit their lifespan due to deterioration or damage. The agents are listed in Section A.1.

Archivist – a professional responsible for managing and providing access to archival and manuscript collections

Collections Manager – a professional responsible for managing and providing access to museum collections

Conservator (museum object) – a person trained in the theoretical and practical aspects of preventive conservation and in performing treatments to prolong the lives of museum objects. Most conservators specialize in specific classes of objects (for example, paintings, furniture, books, paper, textiles, metals, ceramics and glass, architecture, ethnographic objects, archeological objects, photographs). They formulate and implement conservation activities in accordance with an ethical code such as the AIC Code of Ethics and Guidelines for Practice.

Curator – in the NPS, a person professionally responsible for the management, preservation, and use of museum objects/specimens. Collection management responsibilities include acquisition and disposal, documentation and cataloging, preventive conservation, storage, access, interpretation and exhibition, and research and publication. Often the curator is a discipline or material culture specialist (for example, archeology, history, biology, fine arts, Civil War weapons). Curators on park staffs who work directly with collections are known as museum curators; curators in other offices generally are known as staff curators. In the absence of archivists, curators are normally responsible for historic documents.

Object Conservation – measures taken to prolong the life of a museum object and its associated data

Preservation – the act or process of applying measures to sustain the existing form, integrity, and material of an object by activities that minimize chemical and physical deterioration and damage and prevent loss of information; primary goal of preservation is to prolong the existence of cultural property

Preventive Care (or Preventive Conservation) – non-interventive actions taken to prevent damage to and minimize deterioration of a museum object. Such actions include monitoring, recording, and controlling environmental agents; inspecting and recording the condition of objects; establishing an integrated pest management program; practicing proper handling, storage, exhibit, housekeeping and packing and shipping techniques; and incorporating needed information and procedures about objects in emergency operation plans.

Reformatting – for preservation, producing a copy of an original item or copy in the same or a different format to preserve the information it contains. Making a copy negative or digital copy of an original photographic negative is an example of reformatting.

Restoration – interventive treatment action taken to bring an object as close as possible to its original or former appearance by removing accretions and later additions and/or by replacing missing elements

Stabilization – interventive treatment action taken to increase the stability or durability of an object when preventive conservation measures fail to decrease its rate of deterioration to an acceptable level or when it has deteriorated so far that its existence is jeopardized

Treatment – the deliberate alteration of the chemical and/or physical aspects of museum objects, aimed primarily at prolonging their existence; treatment may consist of stabilization and/or restoration

G. Selected Bibliography

- American Institute for Conservation of Historic and Artistic Works. "AIC definitions of Conservation Terminology." *AIC Directory*, 1998.
- Canadian Conservation Institute. *CCI Notes*. Ottawa, Ontario: Canadian Conservation Institute, n.d.
- _____. Framework for Preservation of Museum Objects (poster). Ottawa, Ontario: Canadian Conservation Institute, n.d.
- Elovitz, Kenneth M. "Practical Guide to HVAC for Museums and Historic Renovation." *ASHRAE Journal* 41, no.4, (1999): 48-98.
- Michaelski, Stephan. *A Systematic Approach to the Conservation (Care) of Museum Collections*. Ottawa, Ontario: Canadian Conservation Institute, 1992.
- Museum Management Program. *Conserve O Gram*. Washington, D.C.: National Park Service, n.d.
- National Committee to Save America's Cultural Collections. *Caring for Your Collections*. New York: Harry N. Abrams, Inc., 1992.
- National Institute for the Conservation of Cultural Property and Getty Conservation Institute. *The Conservation Assessment: A Tool for Planning, Implementation, and Fundraising*. Washington, D.C.: NIC, 1990.
- Rose, Carolyn L., Catherine A. Hawks, and Hugh H. Genoways, eds. *Storage of Natural History Collections: A Preventive Conservation Approach*. Iowa City, Iowa: Society for the Preservation of Natural History Collections, 1995.
- Thompson, John M.A. *Manual of Curatorship: A Guide to Museum Practice*. London: Butterworths, 1992.

H. Web Resources

National Park Service Resources

- Museum Management Program: <<http://www.cr.nps.gov/csd/>>
- National Center for Preservation Technology and Training: <<http://www.ncptt.nps.gov/>>
- Harpers Ferry Center Conservation: <<http://www.nps.gov/hfc/hfc-doc.htm>>

Other Resources

- Conservation On-Line: <<http://palimpsest.stanford.edu/>> (Almost all conservation and preservation resources can be reached through this site.)
- American Institute for Conservation of Historic and Artistic Works (AIC): <<http://palimpsest.stanford.edu/aic/>>
- Canadian Conservation Institute (CCI): <<http://www.pch.gc.ca/cci-icc/>>

SCOPE OF WORK (Sample)
Collection Condition Survey

[Park Name]

I. Background Statement

[Provide information on the size and breadth of collections and why a Collection Condition Survey is needed.]

The park requesting a Collection Condition Survey of collections is:

[name - address - telephone number]

II. Purpose/Objectives

A. The purpose of the work is to 1) conduct an on-site Collection Condition Survey (CCS) at [park]; and 2) produce a report identifying the conservation and preservation needs of individual objects stored and exhibited at the park. The results of the survey will provide guidance to the park and Regional curatorial staff in setting priorities for object stabilization and/or treatment, and preservation management of the park collections. The survey will also facilitate budgeting, scheduling, and subsequent communications with conservators regarding treatment. Object-specific data from the survey will be entered into ANCS+, the park's automated collections management system.

The focus of the survey is upon conservation treatment needs, i.e., on determining and recording the conditions of individual objects or groups of objects in the collection which are in need of some form of professional conservation treatment or treatment by technicians with the input of a conservator. Secondary information will include recommendations for preventive care, and improvements to storage and exhibit conditions.

B. The Surveyor must comply with the *Code of Ethics and Guidelines for Practice* of the American Institute for Conservation of Historic and Artistic Works (AIC) in all work performed.

C. A time will be set for the site visit in conjunction with the park Superintendent and the Surveyor when it is convenient for both.

D. Prior to the visit the park will provide:

- a copy of the Scope of Collection Statement (SOCS),
- any previous surveys or reports that may assist the conservator in understanding the history of park collections including:
 - Collection Management Plan
 - Collection Storage Plan
 - environmental monitoring records
 - fire protection or security surveys
 - Emergency Operation Plan (EOP)
 - Structural Fire Plan
- significance criteria, if available, for all objects to be evaluated by the conservator. This information will be entered into ANCS+ before the survey takes place.

The conservator may provide the park with a pre-visit survey that will be completed before the visit.

Figure 3.2. Sample Scope of Work for Requesting a Collection Condition Survey

- E. Except as may be additionally approved in advance by the Superintendent, the park staff will provide on-site:
- significance criteria, if available, for all objects to be evaluated by the conservator. This information will be entered into ANCS+ before the survey takes place.
 - a suitable work space
 - access to collection storage rooms, vaults, cabinets, shelves, and other locations of museum objects
 - opening and closing of storage cabinets and vault or other containers that may be locked
 - assistance with moving heavy or unwieldy objects
 - access to museum property accountability (catalog and accession) and conservation (treatment and survey) records when required
 - answers to questions about such matters as existing environmental monitoring and control, preventive care of objects, uses of objects, plans for future acquisition and disposition of objects, and the park's pest management program
 - other information as reasonably may be needed

III. Tasks

A. The conservator will conduct an entrance interview upon arrival at the park with the Superintendent with designated park staff (curatorial, maintenance and other cultural resources staff). The purpose of the interview is to explain to the staff the Surveyor's methodology and anticipated schedule for the survey and to detail any local support that may be expected.

B. Conduct a hands-on survey of collections by examining each object individually, or, as appropriate, by examining representative samples of large groups of essentially identical objects. The following factors shall be considered in determining the condition of an object and conservation treatment needs:

- The nature of the environment in which collections are stored or exhibited including building construction, temperature, relative humidity, dust, natural and artificial light sources, pests, and other agents of deterioration.
- Storage methods, mounts, and techniques including appropriateness, quality, and efficiency of use.
- Evidence of recent damage or deterioration, including failure of preservation treatments, damage to objects during their use for interpretation and study, effects of visitor handling or vandalism, and deterioration due to adverse environmental factors.
- Any other general or specific issues concerning the collection's preservation, conservation, and/or treatment needs.

C. Upon completion of the survey, the conservator will meet with the park Superintendent and designated curatorial staff to go over the results of the survey. The close-out meeting should cover substantially the same subjects and recommendations the surveyor anticipates including in his/her report. At this time, the conservator will gather any data or information not already obtained that will be required for production of the survey report.

D. The conservator will prepare a written report of the survey just completed. The report shall include the following elements:

- Brief description of the schedule, sequence, procedures, and methodology used in conducting the survey in the park; identification of person(s) conducting the survey; identification of park staff who were involved in the survey and how they were involved; a brief summary of the entrance and exit interviews.

Figure 3.2. Sample Scope of Work for Requesting a Collection Condition Survey (continued)

- Condition information on individual items or groups of items in an electronic format.

This information must be transferable to the Conservation Module in ANCS+. [Required and optional fields are described fully in the *ANCS+ User Manual*.] The contractor will provide these fields on disk using an Access template provided by the NPS or using the ANCS+ Conservation Module provided by the park. The park will transfer this information to the ANCS+ files.

E. When preventive maintenance treatment or simple treatments that can be carried out by park staff are identified, the treatment should be described briefly. When simple treatments are described, the materials to be used should also be recommended. All recommended materials should be those commonly used by conservators and selected for reversibility, stability, and ease of use. Materials should be described generically, though brand names also may be given for reference purposes.

F. Provide instructions for the park curatorial staff to follow when carrying out work that the Surveyor recommends they perform. In most instances, such instructions will have been previously prepared for another institution or will be copied from published works.

G. Provide estimate of time required for a professional conservator to carry out each recommended treatment. If possible, provide an estimate of what the treatment would cost if done by a conservator specializing in that work. The park can use this information to program funds to accomplish the work. When appropriate, note economies of cost or other benefits that might be realized by simultaneously treating similar objects, or objects with similar treatment needs.

IV DELIVERABLES AND PAYMENT SCHEDULE

A. Five copies of the draft survey report on 8 1/2" x 11" paper, single sided with each line numbered at the left side of the page shall be provided. A title page is required indicating the name of the park, the Surveyor's name, and completion date of the project. A table of contents may be necessary. Individual object information must also be provided in electronic format as described in the *ANCS+ User Manual*.

B. The Surveyor's report must be on 8 1/2" x 11" neutral pH, high alphacellulose, white paper such as Permalife Bond Paper from Howard Paper Mills or equivalent, single -sided, with page numbers in carbon-based, black laser printer ink. A title page is required indicating the name of the park, the Surveyor's name, and completion date of the project. A table of contents may be necessary. One hard copy and an electronic copy should be provided. The diskette should be labeled with the same title as the report plus the file name. Any revised individual object information must also be provided in electronic format as described in the *ANCS+ User Manual*.

C. Photographic documentation must be in black and white with both the negative and a 4" x 5" print supplied. All photographs must meet ANSI specifications (see information in Appendix R). Surveyor must sign a release form granting copyrights to all photographs to the park. (See *NPS Museum Handbook*, Part III, Figure 3.4, Assignment of Copyright by Contractor.) Surveyor may keep a copy of each image for private or educational use. Images kept by the contractor may not be used in for-profit publications, for commercial distribution, or for exhibitions by the surveyor or any other individual or institution without written permission from the Superintendent or Park Curator. The credit line shall include the following information: "Courtesy of the National Park Service," Park Name, Object Name, Object Date, Catalog Number.

D. A separate sheet of photographic captions will be prepared and the file will be on the diskette with the report. When applicable, the captions will link directly to an object's accession or catalog number. The number shall be written in carbon black ink or pencil on the non-emulsion side of the image on the border or non-image area in neat, easily readable print.

Figure 3.2. Sample Scope of Work for Requesting a Collection Condition Survey (continued)

E. Digital images shall be recorded for supplementary documentation of each object. A copy of each file, in uncompressed TIFF format, shall be provided to the park with sufficient information to allow transfer of the image into ANCS+. JPEG files or any form of lossy compression files will not be accepted.

F. Payment shall be made in two phases.

- Phase I involves the site visit and preparation of the DRAFT Collection Condition Survey. The first draft will be due 30 days following the site visit (or sooner if the Surveyor elects to do so). Upon receipt of the draft document and an invoice, 50% of the total sum will be delivered to the contractor. The park will provide government review comments within 30 days.
- Phase II includes delivery of the final document, which is due 30 days following receipt of the review comments. Phase II payment of the remaining 50% of the total sum will be delivered upon receipt and acceptance of the final documents and receipt of an invoice.

The final Collection Condition Survey shall be sent to:

[name - address - telephone number]

Figure 3.2. Sample Scope of Work for Requesting a Collection Condition Survey (continued)

Project Description:

The park has a collection of approximately 300 desiccated wood and fiber objects recovered from dry caves throughout the Southwest. These materials include basketry, sandals, textiles, cordage, and a number of small wooden artifacts. In 1998 a conservator carried out a Collection Condition Survey on this collection. Items were prioritized for treatment and a basic treatment methodology was recommended.

Needs include stabilization of loose fragments, basic cleaning, removal of deposits from burial and construction of specialized mounts. Conservation treatment will also identify fiber and wood types and construction methodology. These objects are primary sources for archeological research and conservation treatment is necessary so that the materials can safely be made available to researchers for study. Analysis carried out during treatment will add to the documentation available on these objects.

Figure 3.3. Example Project Management Information System (PMIS) Statement for Requesting Conservation Treatment Based on CCS

Chapter 4: Museum Collections Environment

A. Overview	4:1
What information will I find in this chapter?	4:1
Who should read this chapter?	4:1
What are the agents of deterioration that affect the museum environment?	4:1
B. Developing the Critical Eye	4:3
What is the "critical eye"?	4:3
What kinds of materials will I find in a museum collection?	4:4
What is deterioration?	4:5
What is chemical deterioration?	4:6
What is physical deterioration?	4:6
What is inherent vice?	4:7
Why is it important to understand the environmental agents of deterioration and how to monitor them?	4:8
C. Temperature	4:9
What is temperature?.....	4:9
How does temperature affect museum collections?.....	4:9
D. Relative Humidity	4:9
What is relative humidity (RH)?.....	4:9
What is the psychrometric chart?	4:10
How do organic objects react with relative humidity?	4:13
What deterioration is caused by relative humidity?.....	4:13
What are the recommendations for relative humidity control?	4:13
E. Monitoring and Controlling Temperature and Relative Humidity	4:14
Why should I monitor temperature and relative humidity?.....	4:14
What kind of monitoring equipment should I have?	4:15
How do I maintain a hygrothermograph?	4:18
How do I read a hygrothermograph chart or datalogger graph?.....	4:22
How do I use the hygrothermograph or datalogger data?.....	4:23
How do I organize and summarize the data from my hygrothermograph charts or datalogger graphs?	4:23
How do I summarize long-term data?	4:28
How do I control temperature and relative humidity?	4:29
What are humidistatically controlled heating and ventilation systems?.....	4:33
What is the time-weighted preservation index (TWPI)?.....	4:33
F. Light	4:33
What is light?.....	4:34
What are the standards for visible light levels?.....	4:35
G. Monitoring and Controlling Light	4:37
How do I monitor light levels?	4:37
How do I improve the lighting to minimize damage to objects on exhibit or in storage?	4:38
How do I limit light damage from research use?.....	4:39
How do I fill out the Light and Heat Measurement Record?	4:40
Is there any way to directly monitor light damage?	4:42
How do I control light levels?	4:42
H. Dust and Gaseous Air Pollution	4:43
What are particulate air pollutants?	4:44
What are gaseous air pollutants?	4:44

I. Monitoring and Controlling Particulate and Gaseous Air Pollution	4:46
How do I monitor air pollution?	4:46
Are there ways to monitor for air pollution?	4:47
How do I control air pollution?	4:48

J. Selected Bibliography	4:51
---------------------------------------	------

K. Endnotes	4:53
--------------------------	------

List of Figures

Figure 4.1. How to Use a Psychrometric Chart	4:12
Figure 4.2. Relative Humidity Optimum Ranges for Various Materials Housed in a Park's Museum Collection	4:14
Figure 4.3. Example Hygrothermograph Calibration Record	4:21
Figure 4.4. Hygrothermograph Chart that Illustrates the Relationship Between Temperature and Relative Humidity	4:24
Figure 4.5. Hygrothermograph Chart that Indicates Operation of Air Handling Equipment	4:25
Figure 4.6. Hygrothermograph Chart that Illustrates the Results of Turning off the Furnace	4:26
Figure 4.7. Museum Environmental Monitoring Record	4:27
Figure 4.8. Example Light and Heat Measurement Record	4:41
Figure 4.9. Deterioration to Museum Objects Caused by Air Pollution	4:46
Figure 4.10 Types of Materials that Can Harm Objects and Types of Materials that are Considered Safe to Use with Museum Objects for Storage and Exhibit	4:50

CHAPTER 4: MUSEUM COLLECTIONS ENVIRONMENT

A. Overview

1. *What information will I find in this chapter?*

This chapter will give you information on how to protect your collection from deterioration caused by interaction with the surrounding environment. From the moment an object is created, it begins to deteriorate. The factors that can cause deterioration are called “agents of deterioration.” See Chapter 3 for a more complete discussion of the agents of deterioration.

This chapter will address four agents that can be grouped under the term **environment**:

- temperature
- relative humidity
- light
- air pollution

Understanding how the environment affects your collection and how to monitor and control these agents of deterioration is the most important part of a preventive conservation program.

In order to understand how the agents of deterioration react with the objects in your collection, you must develop a “critical eye.” This skill allows you to identify active deterioration and its causes. How you do this is described below.

2. *Who should read this chapter?*

You should read this chapter if you are responsible for the care of the museum collections. Use this chapter to develop an understanding of how objects deteriorate. This chapter will help you develop environmental monitoring programs so you can identify and block these agents of deterioration before they can damage your collections or so you can mitigate the damage that has been caused. Every park should have an environmental monitoring program.

3. *What are the agents of deterioration that affect the museum environment?*

The agents of deterioration are forces that act upon objects causing chemical and physical damage.

- **Contaminants** disintegrate, discolor or corrode all types of objects, especially reactive and porous materials. Contaminants include:
 - *gases* (pollutants such as hydrogen sulfide, nitrogen dioxide, sulfur dioxide and ozone; oxygen)
 - *liquids* (plasticizers that ooze from adhesives, grease from human hands)
 - *solids* (dust that can abrade surfaces, salt that corrodes metals)

- Air pollution can include all these types of contaminants.
- Radiation can be:
 - *ultraviolet* radiation that disintegrates, fades, darkens, and/or yellows the outer layer of organic materials and some colored inorganic materials
 - *unnecessary visible light* that fades or darkens the outer layer of paints and wood
- Incorrect temperature can be:
 - *too high* causing gradual disintegration or discoloration of organic materials
 - *too low* causing desiccation, which results in fractures of paints, adhesives, and other polymers
 - *fluctuating* causing fractures and delamination in brittle, solid materials
- Incorrect relative humidity can be:
 - *damp (over 65% RH)* causing mold and corrosion
 - *above or below a critical value* hydrating/dehydrating some minerals
 - *above 0%* supports hydrolysis that gradually disintegrates and discolors organic materials, especially materials that are chemically unstable
 - *fluctuating*, which shrinks and swells unconstrained organic materials, crushes or fractures constrained organic materials, causes layered organic materials to delaminate and/or buckle, loosens joints in organic components.

This chapter discusses protection from incorrect temperature, incorrect relative humidity, light (electromagnetic radiation), and pollutants. Other chapters cover the other agents of deterioration. Direct physical forces are discussed in Chapter 7: Handling, Packing and Shipping. Thieves, vandals, and fire are discussed in Chapter 9: Security and Fire Protection. Pests are described in Chapter 5: Biological Infestations. Water and many of the other agents are discussed in Chapter 10: Emergency Operation Plans.

There are a variety of ways you can protect your collections from the agents of deterioration. There are four steps to stop or minimize damage:

- **Avoid the agents of deterioration.** For example, choose a site for your collection storage that is away from the flood plain of a river or

stream. Build a storage facility that is properly insulated and does not have windows in collections areas.

- **Block the agents when you cannot avoid them.** This is probably the main way most museums protect their collections in historic buildings. For example, if your collection storage area has windows, cover them with plywood. Place UV filters on fluorescent lights to block damaging radiation. Fill cracks and gaps in a building structure to limit entry to pests.
- **Test the methods you use to block agents of deterioration by monitoring.** For example, set up an Integrated Pest Management (IPM) program to find out if you have pests. Monitor relative humidity and temperature to find out if your HVAC system is working properly.
- **Respond to information you gather with your monitoring programs.** Monitoring is a waste of time if you do not review, interpret, and use the information. This chapter will tell you how to monitor temperature and relative humidity, light, and air pollution and how to respond to the data that you collect.

Only if these first four approaches fail should you have to recover from deterioration. Recovery usually means treating an object. While a treated object may *look* the same, once damage has occurred, an object will never *be* the same. Your aim in caring for your collection should be to carry out preventive tasks so that treatment is not needed.

Many objects will come to your museum collections damaged and deteriorated from use and exposure. Because of their history, even in the best museum environment, some objects will need treatment. You should develop a treatment plan for immediate problems in the collection. Your primary goal, however, is to create a facility that will minimize damage and maintain the collection through preventive measures.

B. Developing the Critical Eye

1. *What is the “critical eye?”*

The “critical eye” is a way of looking at objects to evaluate their condition and identify reasons for changes in the condition. You develop this skill over a period of time through both training and experience. You must continually ask yourself the questions:

- What is occurring?
- Why is it occurring?
- What does it mean?

The critical eye is a trained eye.

Your trained eyes will focus on the materials and structure of the object and look for visual clues to the agents of deterioration in the environment. A person with a trained eye readily recognizes danger signs, records them and

associates them with the condition of the museum collections, and implements actions to slow down or stop deterioration. Examples of problems that you will see with a trained eye include:

- sunlight falling on a light sensitive surface
- condensation forming on cold surfaces
- water stains appearing on ceilings or walls
- insect residues and mouse droppings

You must learn about the following topics to develop your critical eye:

- types of materials that make up a museum collection
- inherent characteristics of objects
- types of deterioration

The success of a preventive conservation program relies on the gathering, recording, and evaluating of all this information in order to implement solutions and to mitigate environmental factors that are harmful to a park's museum collection.

2. *What kinds of materials will I find in a museum collection?*

Museum objects are often divided into three material-type categories: organic, inorganic, and composite. You must understand the properties of each of the materials in each of these categories.

Organic Objects: Organic objects are derived from things that were once living — plants or animals. Materials are processed in a multitude of ways to produce the objects that come into your collections. Various material types include wood, paper, textiles, leather and skins, horn, bone and ivory, grasses and bark, lacquers and waxes, plastics, some pigments, shell, and biological natural history specimens.

All organic materials share some common characteristics. They:

- contain the element carbon
- are combustible
- are made of complicated molecular structures that are susceptible to deterioration from extremes and changes in relative humidity and temperature
- absorb water from and emit water to the surrounding air in an ongoing attempt to reach an equilibrium (hygroscopic)
- are sensitive to light
- are a source of food for mold, insects, and vermin

Inorganic Objects: Inorganic objects have a geological origin. Just like organic objects, the materials are processed in a variety of ways to produce objects found in your collections. Material types include: metals, ceramics, glass, stone, minerals, and some pigments.

All inorganic objects share some common characteristics. They:

- have undergone extreme pressure or heat
- are usually not combustible at normal temperature
- can react with the environment to change their chemical structure (for example, corrosion or dissolution of constituents)
- may be porous (ceramics and stone) and will absorb contaminants (for example, water, salts, pollution, and acids)
- are not sensitive to light, except for certain types of glass and pigments

Composite Objects: Composite or mixed media objects are made up of two or more materials. For example, a painting may be made of a wood frame and stretcher, a canvas support, a variety of pigments of organic and inorganic origin, and a coating over the paint. A book is composed of several materials such as paper, ink, leather, thread, and glue. Depending on their materials, composite objects may have characteristics of both organic and inorganic objects. The individual materials in the object will react with the environment in different ways. Also, different materials may react in opposition to each other, setting up physical stress and causing chemical interactions that cause deterioration.

3. *What is deterioration?*

Deterioration is any physical or chemical change in the condition of an object. Deterioration is inevitable. It is a natural process by which an object reaches a state of physical and chemical equilibrium with its immediate environment.

The types of deterioration can be divided into two broad categories: physical deterioration and chemical deterioration. Both types often occur simultaneously.

4. *What is chemical deterioration?*

Chemical deterioration is any change in an object that involves an alteration of its chemical composition. It is a change at the atomic and molecular level. Chemical change usually occurs because of reaction with another chemical substance (pollution, water, pest waste) or radiation (light and heat). Examples of chemical change include:

- oxidation of metals (rusting)
- corrosion of metals and stone caused by air pollution
- damage to pigments by air pollution or reaction with other pigments
- staining of paper documents by adjacent acidic materials

- fading of dyes and pigments
- darkening of resins
- darkening and embrittlement of pulp papers
- burning or scorching of material in a fire
- embrittlement of textile fibers
- bleaching of many organic materials
- cross-linking (development of additional chemical bonds) of plastics
- rotting of wood by growing fungus

5. *What is physical deterioration?*

Physical deterioration is a change in the physical structure of an object. It is any change in an object that does not involve a change in the chemical composition. Physical deterioration is often caused by variation in improper levels of temperature and relative humidity or interaction with some mechanical force. Examples of physical deterioration include:

- melting or softening of plastics, waxes, and resins caused by high temperature
- cracking or buckling of wood caused by fluctuations in relative humidity
- warping of organic materials caused by high relative humidity
- warping or checking of organic materials caused by low relative humidity
- shattering, cracking, or chipping caused by impact
- crushing or distortion caused by a harder material pressing against flexible material
- abrasion caused by a harder material rubbing against a softer material
- structural failure (for example, metal fatigue, tears in paper, rips in textiles)
- loss of organic material due to feeding by insects and/or their larvae
- staining of textiles and paper by mold

Physical deterioration and chemical deterioration are interrelated. For example, chemical changes in textiles caused by interaction with light also weaken the fabric so that physical damage such as rips and tears may occur.

6. What is inherent vice?

In addition to deterioration caused by the agents of deterioration, certain types of objects will deteriorate because of their internal characteristics. This mechanism of deterioration is often called ***inherent vice*** or ***inherent fault***. It occurs either because of the incompatibility of different materials or because of poor quality or unstable materials.

In nature, materials often possess characteristics that protect them from natural degradation. Their structure and composition may include features such as protective layers, insect and mold resistant chemicals, and photochemical protection. Processing during object manufacture can remove these natural safeguards. Additives may be applied to give a desired result, without concern for long-term preservation (for example, the addition of metal oxides in the manufacture of weighted silk). This processing results in inherently less stable materials or combinations of mutually incompatible substances that have damaging interaction. There are three kinds of inherent vice:

Short-lived materials: Short-lived materials are often the result of manufacturing processes that do not consider the long-term stability of the items that were produced. Many objects now in park museum collections originally were made to fulfill temporary needs. Examples of impermanent materials with inherent vice include:

- cellulose nitrate and cellulose ester film
- wood pulp paper
- many 20th century plastics
- magnetic media, including electronic records

Structural nature: Inherent vice can also be related to the structure of an object. Poor design, poor construction, or poor application of materials may cause structural failure. Examples of such damage include:

- drying cracks in paint improperly applied
- broken or lost attachments
- loose joints

History: The way an object was used or where it was stored or deposited before it comes into your collection may lead to inherent vice. Here, damage and deterioration is caused by the original function of the object, its maintenance, or its environment. Examples of inherent vice caused by history include:

- accumulation of dissimilar paint layers, such as oil and latex
- saturation in a wooden bowl that had been used as a container for oil
- deposits of soluble salts in an archeological ceramic during burial

You may have trouble identifying deterioration caused by inherent vice because often there is little or no information on the selection and processing of materials, manufacturing details, and previous use of an object. Train your critical eye by reviewing similar objects and by developing knowledge of object technology. Over time, you will become more proficient at identifying inherent vice.

7. *Why is it important to understand the environmental agents of deterioration and how to monitor them?*

If you understand basic information about the chemistry and physics of temperature, relative humidity, light, and pollution, you will be better able to interpret how they are affecting your museum collections. This chapter gives you a basic overview of these agents and describes how to monitor them. You will be able to tell how good or bad the conditions in your museum are and whether or not the decisions you make to improve the environment are working the way you expect.

The rest of this chapter gives you guidelines for deciding on the best environment that you can provide for your collections. However, because of the huge variation in materials found in collections and the extremes in geography where NPS collections are stored, no strict standards can be set. In the past, simplified standards such as 50% RH and 65°F were promoted. With research and experience, it is now understood that different materials require different environments. You must understand the needs of your collection for the long-term in order to make thoughtful decisions about proper care.

You will want to develop microenvironments for storage of particularly fragile objects. A microenvironment (microclimate) is a smaller area (box, cabinet, or separate room) where temperature and/or humidity are controlled to a different level than the general storage area. Common microenvironments include:

- freezer storage for cellulose nitrate film
- dry environments for archeological metals
- humidity-buffered exhibit cases for fragile organic materials
- temperature-controlled vaults for manuscript collections

C. Temperature

1. *What is temperature?*

Temperature is a measure of the motion of molecules in a material. Molecules are the basic building blocks of everything. When the temperature increases, molecules in an object move faster and spread out; the material then expands. When the temperature decreases, molecules slow down and come closer together; materials then contract. Temperature and temperature variations can directly affect the preservation of park collections in several ways.

2. *How does temperature affect museum collections?*

Temperature affects museum collections in a variety of ways.

- At higher temperatures, chemical reactions increase. For example, high temperature leads to the increased deterioration of cellulose nitrate

film. If this deterioration is not detected, it can lead to a fire. As a rule of thumb, most chemical reactions double in rate with each increase of 10°C (18°F).

- Biological activity also increases at warmer temperatures. Insects will eat more and breed faster, and mold will grow faster within certain temperature ranges.
- At high temperatures materials can soften. Wax may sag or collect dust more easily on soft surfaces, adhesives can fail, lacquers and magnetic tape may become sticky.

In exhibit, storage and research spaces, where comfort of people is a factor, the recommended temperature level is 18-20° C (64-68° F). Temperature should not exceed 24° C (75° F). Try to keep temperatures as level as possible.

In areas where comfort of people is not a concern, temperature can be kept at much lower levels—but above freezing.

Avoid abrupt changes in temperature. It is often quick variations that cause more problems than the specific level. Fluctuating temperatures can cause materials to expand and contract rapidly, setting up destructive stresses in the object. If objects are stored outside, repeated freezing and thawing can cause damage.

Temperature is also a primary factor in determining relative humidity levels. When temperature varies, RH will vary. This is discussed in more detail in the next section.

D. Relative Humidity

1. *What is relative humidity (RH)?*

Relative humidity is a relationship between the volume of air and the amount of water vapor it holds at a given temperature. Relative humidity is important because water plays a role in various chemical and physical forms of deterioration. There are many sources for excess water in a museum: exterior humidity levels, rain, nearby bodies of water, wet ground, broken gutters, leaking pipes, moisture in walls, human respiration and perspiration, wet mopping, flooding, and cycles of condensation and evaporation.

All organic materials and some inorganic materials absorb and give off water depending on the relative humidity of the surrounding air. Metal objects will corrode faster at higher relative humidity. Pests are more active at higher relative humidities.

We use relative humidity to describe how saturated the air is with water vapor. “50% RH” means that the air being measured has 50% of the total amount of water vapor it could hold at a specific temperature. **It is important to understand that the temperature of the air determines how much moisture the air can hold.** Warmer air can hold more water vapor. This is because an increase in the temperature causes the air molecules to move faster and spread out, creating space for more water

molecules. For example, warm air at 25°C (77°F) can hold a maximum of about 24 grams/cubic meter (g/m^3), whereas cooler air at 10°C (50°F) can hold only about 9 g/m^3 .

Relative humidity is directly related to temperature. In a closed volume of air (such as a storage cabinet or exhibit case) where the amount of moisture is constant, a rise in temperature results in a decrease in relative humidity and a drop in temperature results in an increase in relative humidity. For example, turning up the heat when you come into work in the morning will decrease the RH; turning it down at night will increase the RH.

Relative humidity is inversely related to temperature. In a closed system, when the temperature goes up, the RH goes down; when temperature goes down, the RH goes up.

2. *What is the psychrometric chart?*

The relationships between relative humidity, temperature, and other factors such as absolute humidity and dew point can be graphically displayed on a **psychrometric chart**. Refer to Figure 4.1 for an explanation of how to use this chart. The following definitions will help you understand the factors displayed on the chart and how they affect the environment in your museum.

- **Absolute humidity** (AH) is the quantity of moisture present in a given volume of air. It is not temperature dependent. It can be expressed as grams of water per cubic meter of air (g/m^3). A cubic meter of air in a storage case might hold 10 g of water. The AH would be 10 g/m^3 .
- **Dew point** (or saturation temperature) is the temperature at which the water vapor present saturates the air. If the temperature is lowered the water will begin to condense forming dew. In a building, the water vapor may condense on colder surfaces in a room, for example, walls or window panes. If a shipping crate is allowed to stand outside on a hot day, the air inside the box will heat up, and water will and condense on the cooler objects.
- **Relative humidity** relates the moisture content of the air you are measuring (AH) to the amount of water vapor the air could hold at saturation at a certain temperature. Relative humidity is expressed as a percentage at a certain temperature. This can be expressed as the equation:

$$\text{RH} = \frac{\text{Absolute Humidity of Sampled Air} \times 100}{\text{Absolute Humidity of Saturated Air at Same Temperature}}$$

Use the following example to understand how this concept relates to your museum environment.

In many buildings it is common to turn the temperature down in the evenings when people are not present. If you do this in your storage space, you will be causing daily swings in the RH. Suppose you keep the air at 20°C (68°F) while people are working in the building. A cubic meter of air in a closed space at 20°C (68°F) can hold a maximum of 17 grams of water

vapor. If there are only 8.5 grams of water in this air, you can calculate the relative humidity.

The AH of the air = 8.5 grams

The AH of saturated air at 20°C = 17.0 grams

Using the equation above

$$\text{RH} = \frac{8.5 \times 100\%}{17.0} = 50\%$$

50% RH may be a reasonable RH for your storage areas. But, if you turn down the heat when you leave the building at night, the RH of the air in the building will rise rapidly. You can figure out how much by using the same equation. If the temperature is decreased to 15°C (59°F), the same cubic meter of air can hold only about 13 grams of water vapor. Using the same equation

The AH of the air = 8.5 grams

The AH of saturated air at 15°C (59°F) = 13.0 grams

$$\text{RH} = \frac{8.5 \times 100\%}{13.0} = 65\%$$

By turning down the heat each night and turning it up in the morning you will cause a 15% daily rise and fall in RH.

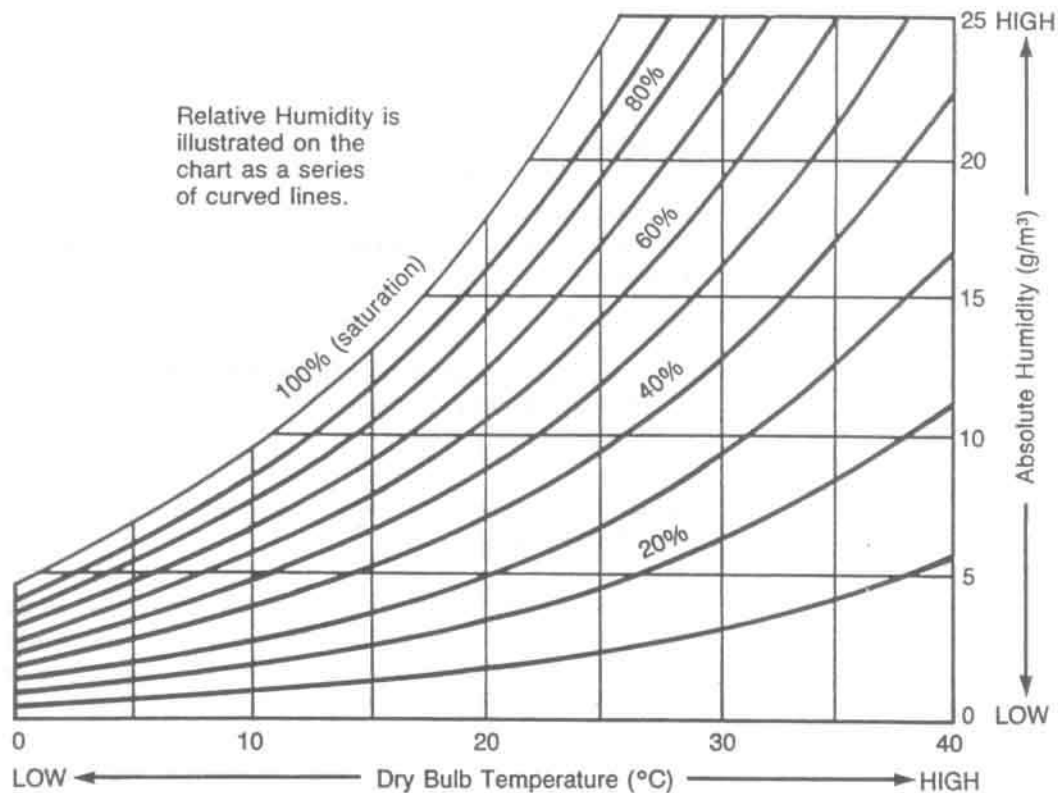

Follow any horizontal line (representing a specific amount of moisture in the air) from left to right on the chart (i.e., from lower to higher temperature levels). Note that RH decreases as temperature increases, so long as the quantity of moisture in the air does not change.

Again, follow any horizontal line, but this time from right to left (i.e., from higher to lower temperatures). Note that RH levels increase, although the amount of moisture in the air remains constant. Finally, 100% RH is reached at the left edge of the chart, when the temperature drops to the dew point. The air is now saturated and will have to give up water (e.g., as condensation) at any lower temperature.

Note that moving from left to right on the chart along the upward curving RH lines corresponds to increasing amounts of moisture in the air. This shows that maintaining a constant level of relative humidity, as the temperature rises, requires adding moisture to the air. Conversely, if the temperature falls, the downward sloping RH lines indicate that water has to be removed from the air to maintain RH at a constant level.

Turning down the heat to increase the RH may be beneficial to a museum collection if the RH is too low. On the other hand, turning down the heat in relatively damp conditions may increase the RH to the level where mold grows, or even to the dew point where condensation may harm vulnerable surfaces.

Figure 4.1. How to Use a Psychrometric Chart

3. *How do organic objects react with relative humidity?*

Organic materials are **hygroscopic**. Hygroscopic materials absorb and release moisture to the air. The RH of the surrounding air determines the amount of water in organic materials. When RH increases they absorb more water; when it decreases they release moisture to reach an equilibrium with the surrounding environment. The amount of moisture in a material at a certain RH is called the **Equilibrium Moisture Content** (EMC). Refer to Appendix N: Curatorial Care of Wooden Objects, for a further explanation of this concept. Over time, these reactions with water can cause deterioration.

4. *What deterioration is caused by relative humidity?*

Deterioration can occur when RH is too high, variable, or too low.

- **Too high:** When relative humidity is high, chemical reactions may increase, just as when temperature is elevated. Many chemical reactions require water; if there is lots of it available, then chemical deterioration can proceed more quickly. Examples include metal corrosion or fading of dyes. High RH levels cause swelling and warping of wood and ivory. High RH can make adhesives or sizing softer or sticky. Paper may cockle, or buckle; stretched canvas paintings may become too slack. High humidity also supports biological activity. Mold growth is more likely as RH rises above 65%. Insect activity may increase.
- **Too low:** Very low RH levels cause shrinkage, warping, and cracking of wood and ivory; shrinkage, stiffening, cracking, and flaking of photographic emulsions and leather; desiccation of paper and adhesives; and desiccation of basketry fibers.
- **Variable:** Changes in the surrounding RH can affect the water content of objects, which can result in dimensional changes in hygroscopic materials. They swell or contract, constantly adjusting to the environment until the rate or magnitude of change is too great and deterioration occurs. Deterioration may occur in imperceptible increments, and therefore go unnoticed for a long time (for example, cracking paint layers). The damage may also occur suddenly (for example, cracking of wood). Materials particularly at high risk due to fluctuations are laminate and composite materials such as photographs, magnetic media, veneered furniture, paintings, and other similar objects.

5. *What are the recommendations for relative humidity control?*

You should **monitor** relative humidity and implement improvements to stabilize the environment. There are many ways to limit fluctuations, not all dependent on having an expensive mechanical system. For example, good control is achievable simply by using well-designed and well-constructed storage and exhibit cases.

Ideally, fluctuations should not exceed $\pm 5\%$ from a set point, each month. You should decide on a set point based on an evaluation of your particular regional environment. Consult your regional/SO curator, a conservator or other expert in museum environments. Establish maximum and minimum levels by assessing the nature and condition of the materials in the collection and the space where they are housed. Establishing ranges is discussed in more detail in Section B. For example, if you are in Ohio you may decide on a set point of $50\% \pm 5\%$. The humidity could go as high as

55% or as low as 45% within a month. If you are in the arid southwest you might choose 35% as your set point as objects have equilibrated at much lower RH levels. Be aware though, you should not allow your RH to go as high as 65% because of the chance that mold might develop. Below 30% some objects may become stiff and brittle.

Over the year you may want to allow *drift*. Drift means that your set point varies in different seasons—usually higher RH in the summer and lower RH in the winter. Allowing drift will often save you money over the long-term as mechanical systems work less to maintain the proper environment. If your collections are housed in a historic structure, preservation of the structure may require drift. It is important to understand that these variations in RH and temperature should be slow and gradual variations (over weeks and months), not brief and variable.

Archeological Materials	
Negligible Climate-Sensitive Materials	30% – 65%
Climate Sensitive Materials	30% - 55%
Significantly Climate Sensitive Materials	30% - 40%
Metals.....	<35%
Natural History Materials	
Biological specimens.....	40% - 60%
Bone and teeth.....	45% - 60%
Paleontological specimens	45% - 55%
Pyrite specimens	<30%
Paintings	40% - 65%
Paper	45% - 55%
Photographs/Film/Negatives	30% - 40%
Other organics (wood, leather, textiles, ivory)	45% - 60%
Metals	<35%
Ceramics, glass, stone	40% - 60%

Figure 4.2. Relative Humidity Optimum Ranges for Various Materials Housed in a Park’s Museum Collection.¹

E. Monitoring and Controlling Temperature and Relative Humidity

1. *Why should I monitor temperature and relative humidity?*

You must monitor temperature and relative humidity so that you know what the environment in your storage and exhibit spaces is like over time. Monitoring helps you:

- set a baseline of temperature and humidity to see if the storage space is adequate
- identify variations in the temperature and humidity throughout collections areas

- monitor equipment to be sure it is working right
- help develop strategies to improve the environment
- identify whether your strategies are working to improve the environment

2. *What kind of monitoring equipment should I have?*

There are a variety of temperature and relative humidity monitoring tools that are available for monitoring the environment in your museum. They can be divided into two types: spot measuring devices and continuous recording devices. Each type is most effective for different specific tasks so you may need to purchase more than one of the following pieces of equipment:

- **Psychrometers:** All parks should have a psychrometer. There are two types: **sling psychrometer** and **aspirating psychrometer**. Of the two, an aspirating psychrometer is more accurate. You use a psychrometer to record daily readings (if you don't have a hygrothermograph), to make spot readings, and to calibrate dial hygrometers and hygrothermographs. See *Conserve O Gram* 3/1, "Using a Psychrometer To Measure Relative Humidity."

A psychrometer gives you the RH by comparing the temperature between a "dry bulb" and "wet bulb." The dry bulb is a mercury thermometer. The wet bulb is an identical thermometer covered with a wetted cotton wick. Because of the cooling effect of evaporating water, the wet bulb reads lower than the dry bulb. The drier the air, the faster the water evaporates and the lower the reading.

To take readings with a sling psychrometer, whirl it around for one minute to pass air over the wet and dry bulbs. Read the wet bulb immediately and record the results. Repeat the process until you get the same readings two times in a row.

The aspirating psychrometer uses a battery powered fan to steadily blow air over the bulb at a set speed. Both these instruments are accurate to $\pm 5\%$. The aspirating psychrometer is more reliable because it minimizes possible errors by the operator and ensures a constant air flow past the wick. Accuracy will also depend on the length of the thermometer and how accurately you can read the temperature.

Before you use a psychrometer, be sure to read the manufacturer's instructions. To ensure you get an accurate reading keep the following points in mind:

- keep wick closely fitted to the thermometer bulb
- do not touch the wick
- keep the wick clean
- use only deionized water to wet the wick
- be sure that the aspirating psychrometer has a good battery

Accuracy of aspirating and sling psychrometers can be affected by altitude, especially at lower relative humidities. At lower atmospheric pressure water evaporates faster, lowering the temperature of the dry bulb more. If your collections are 900 meters or more above sea level, you should obtain pressure-corrected charts, tables, or slide rules or use a pressure correction formula. See the article by Hitchcock and Jacoby (listed in the bibliography) for more information about the effects of high altitude on psychrometers, and indirectly on the equipment that you calibrate using a psychrometer.

- **Hygrometers:** You can use a hygrometer to measure relative humidity levels when you don't have a hygrothermograph or datalogger or in spaces that are too small for psychrometers (for example, inside an exhibit or a storage case). When you use a hygrometer, also record the temperature. There are three types of hygrometers: dial hygrometers, electronic hygrometers, and humidity strips.

In a **dial hygrometer**, a hygroscopic material (often paper) is attached to a hand on a dial. As the hygroscopic material absorbs or gives off moisture, it expands and contracts, causing the hand to move across the dial. Dial hygrometers can be accurate to $\pm 5\%$, but they are very inaccurate at low (<40%) and high (>80%) RH levels. Often they are hard to calibrate, so over time will drift and become inaccurate. See *Conserve O Gram 3/2*, "Calibration of Hygrometers and Hygrothermographs."

Digital hygrometers often have a built-in temperature monitor. If you purchase one of these tools be sure it can be calibrated. They are often calibrated with saturated salt solutions provided in a kit by the manufacturer. Electronic hygrometers can be used to calibrate hygrothermographs if you are sure the hygrometer is in proper calibration.

Humidity indicator strips are a special kind of hygrometer that use paper impregnated with cobalt salts. A series of patches are labeled with RH, usually in 10% increments. The color is blue at low RH levels and pink at high RH levels. Read the RH at the point of change between pink and blue. These strips are inexpensive and can give you some basic understanding of your RH levels at a variety of spots around your building. If used in a moist environment, they can become inaccurate.

- **Hygrothermographs:** Hygrothermographs have been the basic monitoring tool in museums for some time. They give you a continuous record of temperature and humidity variations over a period of 1, 7, 31, or 62 days. The instrument consists of six major components:
 - the housing
 - a temperature element, usually a bimetal strip
 - a relative humidity element, which may be a human hair bundle or a polymer membrane

- linkage arms and recording pens
- a drive mechanism, which may be spring wound or battery operated, that rotates a chart
- a chart, which may be wrapped around a cylindrical drum or be a circular disk

The temperature-sensitive element (the bimetal strip) and the hygroscopic material (for example, the human hair) are connected to arms with pens at their tips. The pens rest on a revolving chart and move up and down as the bimetal strip and the hair react to environmental changes.

Hygrothermographs are accurate within $\pm 3-5\%$ when properly calibrated. They are most accurate within the range of 30-60% RH. **Note:** You must calibrate your hygrothermograph at least quarterly; monthly is better. It is especially important to calibrate your machine if you experience sudden extremes of humidity in your collection areas. See *Conserve O Gram* 3/2, "Calibration of Hygrometers and Hygrothermographs."

- **Electronic datalogger:** Electronic dataloggers have become common in museums. There are a variety of types of dataloggers available at a range of prices. A model that records temperature, relative humidity, and light will meet typical museum needs. The data must be downloaded onto a computer. All datalogger companies provide at least basic software programs that allow you to manipulate the data to produce graphs and tables of information. Most allow you to transfer this information in ASCII format to a spreadsheet program. They require less calibration than hygrothermographs, though they must usually be sent back to the company for calibration.

Many dataloggers do not display data so you will not have any indication of what is occurring in your environment until you download the data. Some now include a liquid crystal display unit. See *Conserve O Gram* 3/3, "Datalogger Applications in Monitoring the Museum Environment" for a discussion of your options when choosing a datalogger. See *Conserve O Gram* 14/6, "Caring for Color Photographs," for information about using the Preservation Environment Monitor (PEM). The PEM is a datalogger that automatically figures the time-weighted preservation index (TWPI). The TWPI is an estimate of how long organic objects will last at a given temperature and RH. See Section F.10 for a further explanation of the TWPI.

Electronic dataloggers can be very useful instruments, but they are not exact replacements for hygrothermographs. Before purchasing all new equipment evaluate what information you need from your continuous monitoring equipment, consider these questions:

- How much can you spend?
- How many areas do you need to monitor?

- Do you need a portable monitor or will it remain in the same place all the time?
- Do you have the computer equipment and knowledge to properly use dataloggers?
- How much time do you have available for changing charts, downloading data, calibrating instruments, and manipulating data.
- How much data manipulation do you require? Can you just review charts or do you want to be able to look at and produce graphs that reflect daily, monthly, and yearly trends?
- Do you need immediate notification of the environment in an area so you can respond to changes?
- Information regarding some kinds of environmental equipment is published in the NPS *Tools of the Trade*. It is important to evaluate equipment available through a variety of other companies, as well. Electronic hygrometers and dataloggers are changing constantly and you should make yourself aware of new options before making your final choice.

3. *How do I maintain a hygrothermograph?*

In order to get the best information possible from your hygrothermograph, you must maintain and calibrate it on a regular basis. Make it a standard maintenance chore that you do at the same time each quarter, or preferably once a month when you change the recording paper.

Before using your instrument, read the manufacturer's instruction for operation and maintenance. Hygrothermographs are delicate instruments and you can easily damage yours by improper handling. See *Conserve O Gram 3/2*, "Calibration of Hygrometers and Hygrothermographs." Keep the following points in mind when changing the paper and calibrating:

- Keep the instrument clean and free of dust.
- Locate the instrument in an area that minimizes vibration, but reflects the environment throughout the room.
- Do not touch the relative humidity sensor.
- Replace the relative humidity sensor when you find you are frequently adjusting the RH calibration.
- Keep the pens clean and free flowing.
- If you have metal tipped pens, use only the glycerine based ink supplied with your instrument. Other types of ink will not work. You can also get felt-tip cartridge pens, which are easier to use. However, these pens have a shorter shelf life. If properly maintained, the metal pen points with ink are more cost effective.

When you calibrate your hygrothermograph, you will check the instrument against known relative humidity and/or temperature levels and make adjustments as necessary. **Note:** Temperature rarely goes out of calibration because the bimetal element is very stable. Use either a sling psychrometer or an aspirating psychrometer to determine the relative humidity. See *Conserve O Gram 3/1*, “Using a Psychrometer to Measure Relative Humidity.” Next adjust the hygrothermograph to match the known conditions. Use the example chart in Figure 4.3, Hygrothermograph Calibration Record, to document the calibration.

Do the calibration:

- Read and follow any suggestions made by the manufacturer concerning calibration of the instrument.
- Record the information requested on the chart: date, time of day, relative humidity reading from the hygrothermograph, and temperature reading from the hygrothermograph.
- Immediately after recording readings obtained from the hygrothermograph, operate the psychrometer **at the same location**, following the manufacturer’s instructions. Record the relative humidity and dry bulb temperature readings on the psychrometer in the spaces provided on the record.
- Adjust the hygrothermograph to match the psychrometer readings. Follow the instructions for making adjustments provided by the instrument’s manufacturer. If the average differences are found to be greater than 1% relative humidity or 1° in temperature, adjust the hygrothermograph up or down to match the calibrating instrument reading. For example, if the hygrothermograph is recording high by 5%, adjust the recording arm so that it shows the proper reading. If the hygrothermograph is recording temperature low by 4°, adjust the recording arm to the actual reading.
- If the hygrothermograph requires calibration, record the temperature and humidity difference in the appropriate spaces. For example, if the relative humidity reading on the hygrothermograph was 48% and the reading from the psychrometer was 45%, record the difference between them as “hygro high by 3% RH.” **Always record differences in terms of whether the hygrothermograph reading is higher or lower than the psychrometer reading** because you are calibrating the hygrothermograph. If there is no difference between the two readings, simply enter “0 difference” in the space.
- Wait for 15 minutes and take another psychrometer reading. Check the reading on the hygrothermograph again. You may need to adjust the instrument because the linkages often require time to equalize.
- If significant differences still exist (over 5%) after a third check, refer to the instruction manual for the hygrothermograph to determine why the instrument might be malfunctioning. Relative humidity readings most often are erroneous because of a broken or dirty hair element. Temperature readings can be in error because of dust or other fouling of the bimetal strip. **Read and follow the manufacturer’s**

**instructions for cleaning, maintaining, and repairing the
hygrothermograph.**

After the calibration has been completed and the hygrothermograph has been adjusted properly, file the calibration record form with the charts from the hygrothermograph. It is important that the forms be kept so that they can be compared to future calibration records on the same instrument in order to determine if there is a pattern of incorrect readings. If it becomes apparent that a hygrothermograph has consistently given incorrect readings, return it to the manufacturer for repairs.

**NATIONAL PARK SERVICE
HYGROTHERMOGRAPH CALIBRATION RECORD**

Hygrothermograph: **Brand** *Weathermeasure* **Model** *5020-A*
 Serial No. *008581* **Property No.** *NP0000105512*

Psychrometer: **Brand** *Cole-Parmer Thermo-hygrometer* **Model** *3309-60*
 Serial No. *942803* **Property No.** *NP0000105409*

Location of Hygrothermograph: *Museum Storage, top of Cabinet 3A*

Name and Title of Person: *Rhonda Fleming, Curator*

DATE	TIME	Relative Humidity Readings			Temperature Readings		
		HYGRO.	PSYCH.	±RH DIFF.	HYGRO.	PSYCH.	±° DIFF.
<i>4/11/99</i>	<i>1300</i>	<i>55%</i>	<i>54%</i>	<i>+1%</i>	<i>65°F</i>	<i>65°F</i>	<i>0°F</i>
<i>5/11/99</i>	<i>800</i>	<i>53%</i>	<i>54%</i>	<i>-1%</i>	<i>65°F</i>	<i>65°F</i>	<i>0°F</i>
<i>6/10/99</i>	<i>1400</i>	<i>55%</i>	<i>55%</i>	<i>0%</i>	<i>65°F</i>	<i>62°F</i>	<i>+3°F</i>

Figure 4.3. Example Hygrothermograph Calibration Record

4. *How do I read a hygrothermograph chart or datalogger graph?*

If you have spent any time inspecting hygrothermograph charts or datalogger graphs you may have observed readings that defy simple explanations. There are many variables that may account for unusual readings. Some of them include:

- the quality and condition of the building where your collection is housed (the “envelope”)
- staff activity
- public visitation
- HVAC equipment performance and failure
- barometric pressure
- weather
- the condition and accuracy of the monitoring equipment
- an unusual source for moisture such as curing concrete, underground cisterns, clogged drains

It is impossible to explain all of the patterns you may encounter in a monitoring program. However, some common patterns and causes can be explained:

- Examine the hygrothermograph chart in Figure 4.4. This pattern clearly illustrates the relationship between temperature and relative humidity. As the temperature goes down, the RH goes up. As the temperature goes up, the RH goes down. You may see this pattern most often in well-enclosed spaces with minimal human activity (for example, a storage space). A large number of people gathering in a room would probably cause an increase in both temperature (because of body heat) and relative humidity (because of perspiration and transpiration).
- Examine the hygrothermograph chart in Figure 4.5. This pattern is characteristic of changes caused by regulated air-handling equipment. In this case, a thermostat is regulating a furnace. The temperature changes are so small (2°F) and rapid that the RH does not vary enough to show up clearly on the chart until a larger, longer swing occurs and is mirrored in the relative humidity.

A similar sawtooth pattern could be seen in the RH if your building had humidification or dehumidification equipment controlled by a humidistat. Cycling is generally harmful to museum materials that respond quickly to environmental change. It is also very difficult to completely eliminate cycling from most ordinary HVAC equipment.

- Examine the hygrothermograph chart in Figure 4.6. You may find that changes in activity on the weekends result in a different pattern on your hygrothermograph charts. In this instance, the furnace was turned

down or off. Note the resulting rise in RH over the course of the weekend. Note too, the high temperatures and the resulting low RH during the week. In this instance, lowering the thermostat setting and keeping the same setting throughout the week would be much better for the museum objects and would conserve energy.

You may need more than one hygrothermograph or datalogger for your monitoring program, especially in a historic structure located in a temperate zone where summers are hot and humid and winters are cold and very dry. You may need to place a hygrothermograph or datalogger in different spaces (for example, basement, first and second floors) to gather enough data to evaluate conditions properly.

5. *How do I use the hygrothermograph or datalogger data?*

Imagine that the record reveals that the conditions within the structure are too damp for most environmentally sensitive objects (for example, furniture and wooden objects, textile and paper objects). Probably the basement will have consistently high RH levels, the first floor will be somewhat drier, and the second floor might be drier than the first floor. If you do find that the building is too damp, there may be problems in your collections. You will need to look with a critical eye for evidence of mold and insect activity and/or damage and for sources of moisture in the structure's walls and basement. For example, rainwater runoff from the roof may be entering the basement through deep window wells and masonry cellar walls.

Once you identify the problem you must take action. While waiting for modifications to correct the runoff problem, you could put a dehumidifier and fans in the basement. Be sure to seek advice on correcting the problem from others who can help including: your regional/SO curator, conservators, historic architects, cultural resources specialists, and maintenance staff.

6. *How do I organize and summarize the data from my hygrothermograph charts or datalogger graphs?*

You must organize the data recorded by each hygrothermograph or datalogger to make it useful in developing strategies. Keep a record of daily observations, noting occurrences, such as, unusual exterior climatic conditions, a leaky roof, re-calibration of the equipment, or an unusual visitation pattern. At the end of each month when you remove the hygrothermograph chart or download datalogger data, compare this information to the daily record. It may help to record unusual occurrences directly on the chart or graph so that it is easy to see how the environment affected temperature and relative humidity.

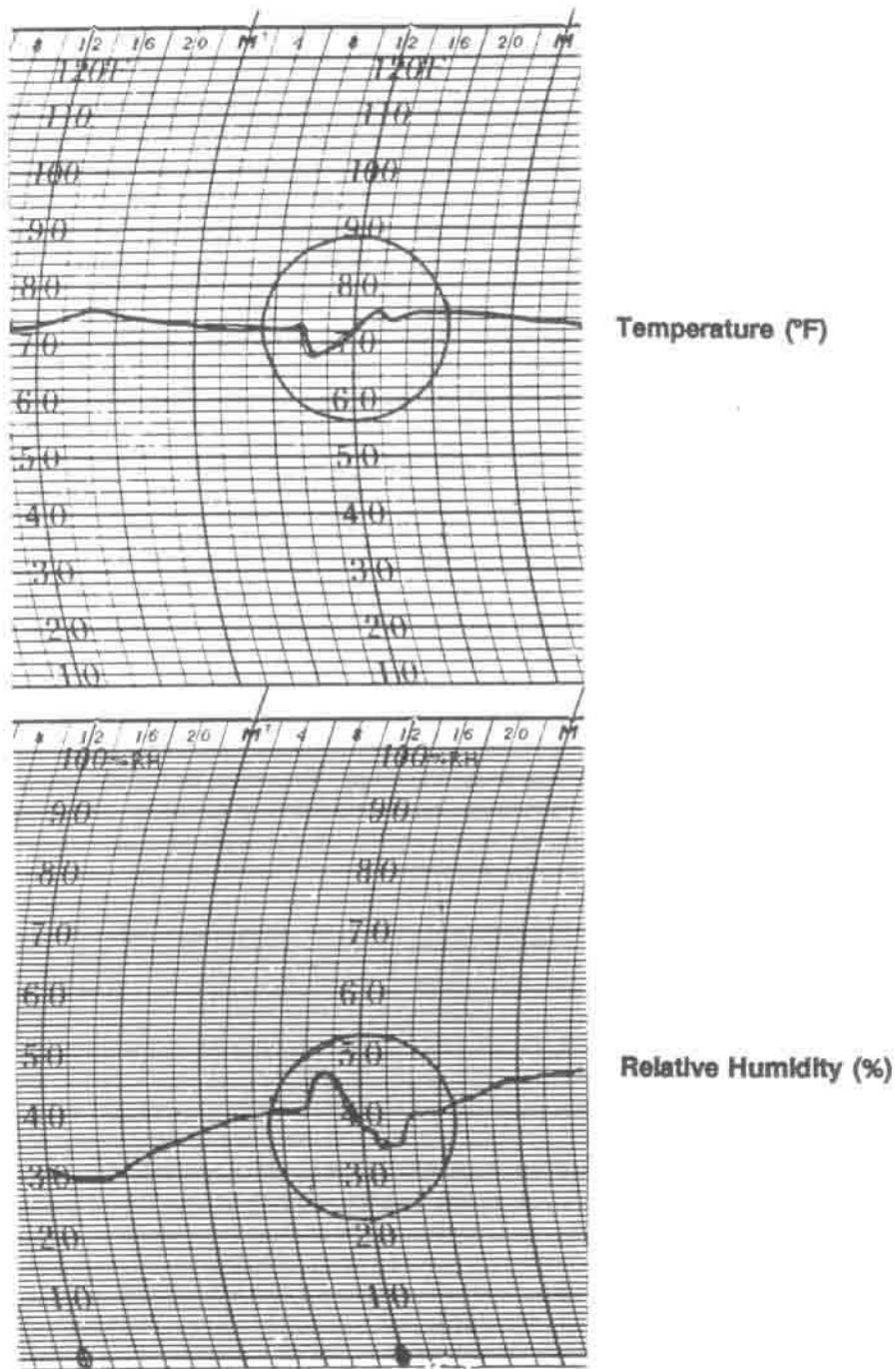

Figure 4.4. Hygrothermograph Chart that Illustrates the Relationship Between Temperature and Relative Humidity

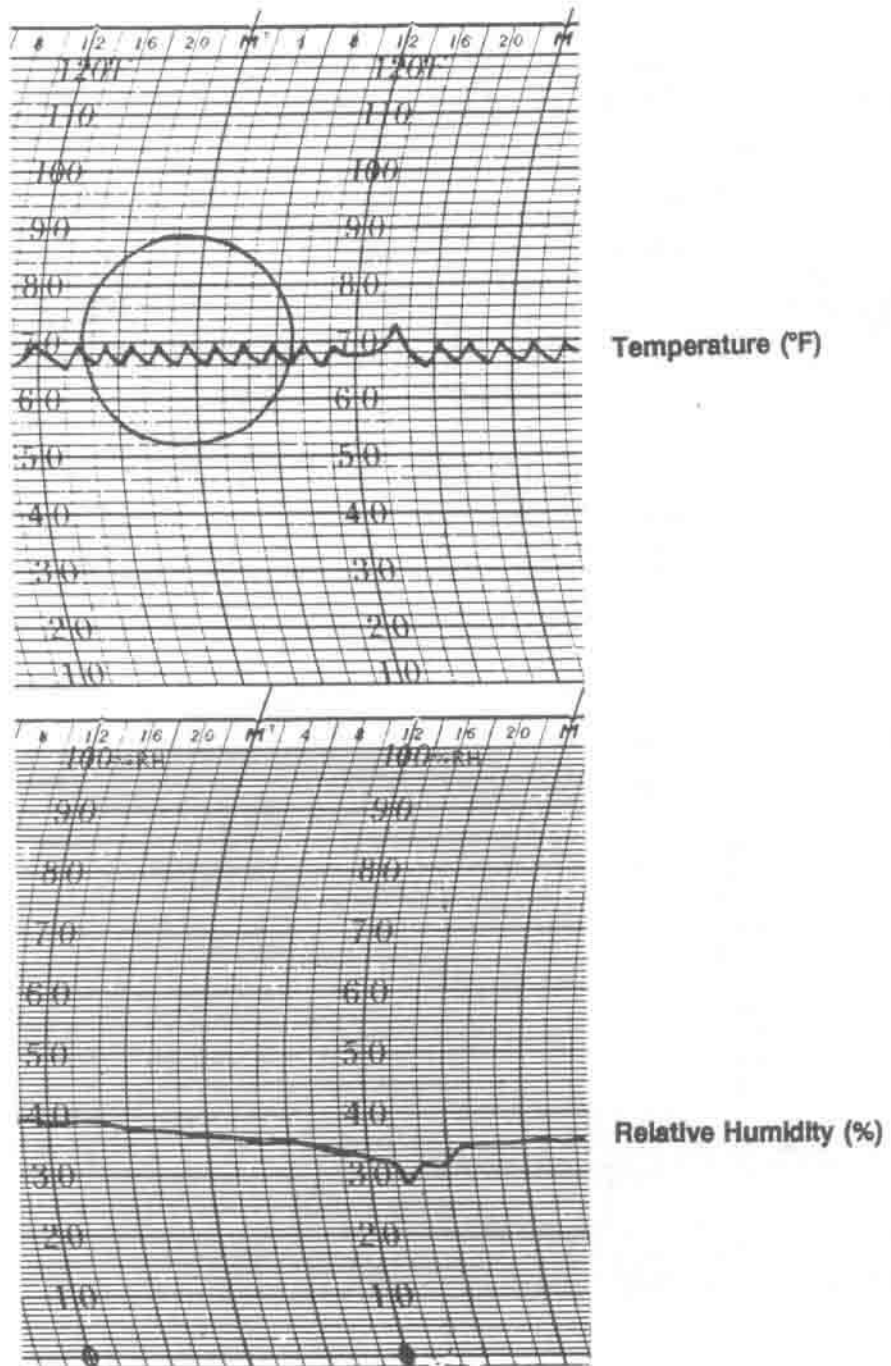

Figure 4.5. Hygrothermograph Chart that Indicates Operation of Air Handling Equipment

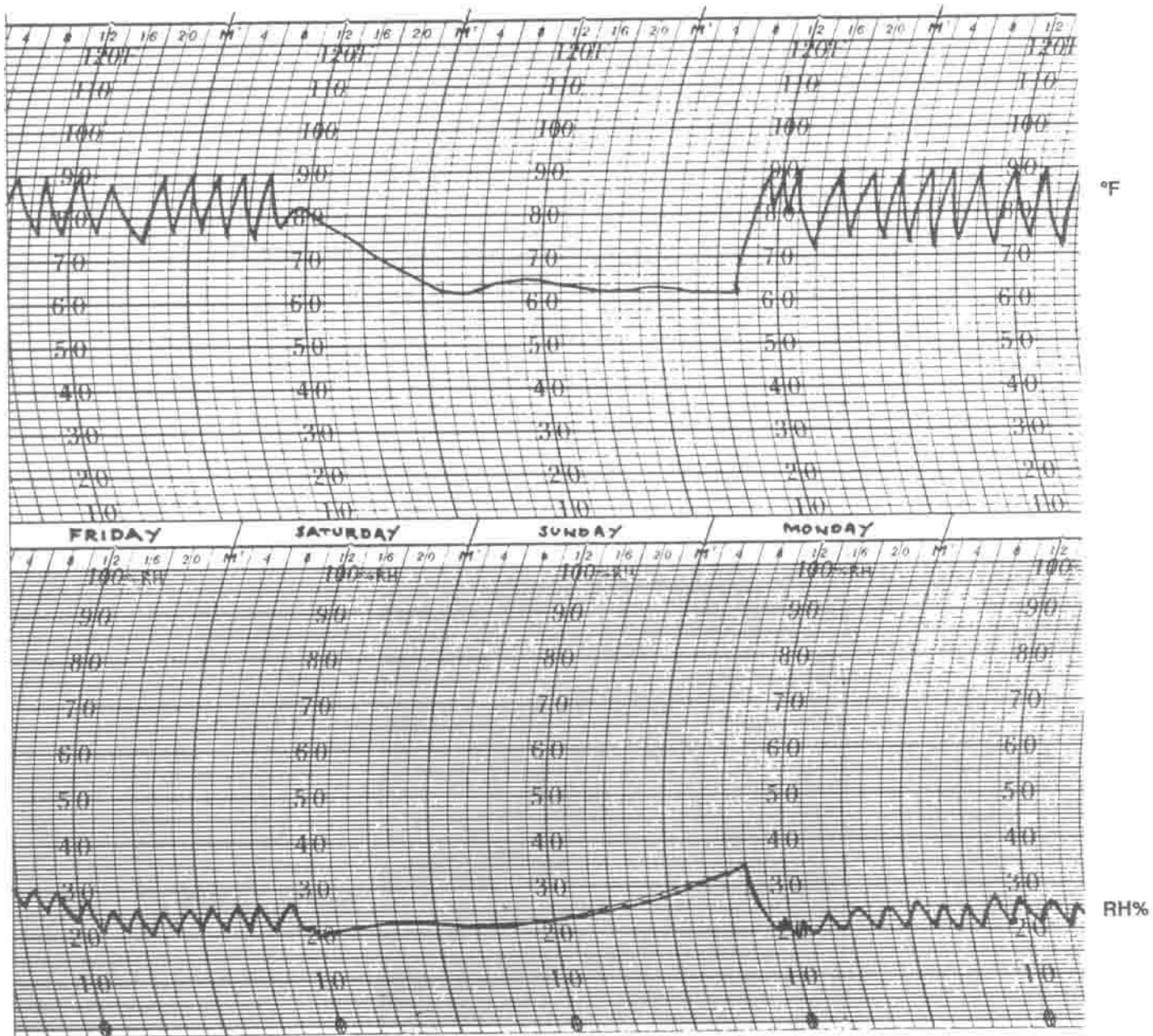

Figure 4.6. Hygrothermograph Chart that Illustrates the Results of Turning off the Furnace

7. *How do I summarize long-term data?*

You can use a table or graph to summarize relative humidity and temperature data. One way is to prepare a table that records information collected over a period of time (for example, four to six weeks). You can put the following information in a table:

- high temperature
- low temperature
- maximum diurnal (24 hour) temperature change
- high relative humidity
- low relative humidity
- maximum diurnal relative humidity change

The following example shows this information recorded for two hygrothermographs in separate museum storage spaces in the park.

Monthly Summary of Temperature and Relative Humidity			
Chart Date	Data	Storage #1	Storage #2
5/18-6/15/99	high temperature	29°C (84°F)	28°C (83°F)
	low temperature	21°C (69°F)	19°C (66°F)
	max. 24 hr. temp. change	4°F	4°F
	high RH	54%	56%
	low RH	45%	46%
	max. 24 hr. RH change	4%	3%

You can also summarize the data using graphs. You can design your graphs in a variety of ways. For example:

- Record both temperature and relative humidity on the same graph.
- Record temperature for several different floors of a historic structure.
- Compare temperature or RH parameters set for a building against recorded data.

You can also summarize data by preparing room-by-room records for a year. Each week, for each room or space:

- Record high/low readings for temperature and relative humidity.
- Record fluctuation patterns of temperature and relative humidity by correlating with the time of day.
- Note maximum diurnal RH fluctuations.

For example:

Furnished Historic Structure	
Room A	Temperature: 18°-22°C (64°-71°F)
5/18-5/24	Gradual rise in relative humidity through week; no rapid fluctuations Gradual daily fluctuations from 18°(64°F) to 22°C (71°F); low about midnight, high around 3 p.m. Relative Humidity: 22% -32% RH Maximum diurnal fluctuations: 10% RH

You should summarize data gathered from instruments and recorded on your monitoring record. This helps you evaluate long-term trends and watch for problems. Summary information helps you develop new environmental control measures.

You can summarize your data for each space by season in the same format as above. A summary gives you an idea of the variation that you have throughout the year.

Use the summary documents in a variety of ways:

- Identify problems with your environment.
- Build an argument about the need to get environmental upgrades or a new building.
- Evaluate whether or not changes you have made really do improve the environment.

8. *How do I control temperature and relative humidity?*

General considerations: When you control the climate surrounding museum objects, you provide a stable environment that eliminates rapid fluctuations and extremes in temperature and RH. When you develop a strategy to control the environment in your museum spaces, keep the following points in mind:

- NPS units are located in many different climate zones, so you must develop acceptable ranges and limits of relative humidity for your individual park. There is no general solution to controlling your relative humidity. Every situation presents different variables that you must evaluate before setting standards. Base your standards on:
 - the local climate (for example, tropical, temperate, arid)
 - the nature and condition of the materials in your collection
 - the nature and condition of the structure housing the collection

- the ability of HVAC equipment to maintain the standard
- the ability of staff to maintain equipment
- In order to develop an effective control program, you must have good information. Collect data for one year before establishing acceptable ranges and limits.
- Use a team approach in controlling relative humidity. Once you have gathered your data, discuss control strategies with your regional/SO curator, and others, such as conservators, historic architects, and mechanical engineers. Strategies for controlling levels of RH and temperature should keep energy costs in mind. Refer to Director's Order #28: *Cultural Resource Management Guideline* for guidance.
- You will need to develop both active and passive measures for controlling the environment. When adapting a historic structure explore the use of simple modifications to your structure or space and employ portable mechanical equipment (humidifier, dehumidifier, heater, and air conditioner) or passive storage controls.
- Once you have implemented strategies to improve the environment, continue monitoring to evaluate whether or not your strategies are working.

Maintain building envelope: With the help of your maintenance division examine the structure and/or museum space for possible sources of moisture. You must eliminate sources of moisture by repairing the structure or correcting drainage problems. Problems that may cause high levels of relative humidity include:

- leaking roof, ceiling, or windows
- gaps in walls, floors, or foundation vapor barrier
- leaking plumbing
- damaged gutters and downspouts
- wet walls and foundations from poor drainage
- open water sources such as sinks or toilets

Passive methods of control: There are a variety of practices that you can adopt to passively control the temperature and RH. Carefully develop a plan to use passive controls. After adopting the practice, continue to monitor to be sure that the action improves that environment the way you expect it to.

- Avoid turning HVAC equipment on during the day and off at night. This practice causes daily fluctuations in RH levels.

- Limit the number of people in a room. Large groups of people can raise the relative humidity from moisture introduced by breathing and perspiring. You may have to open doors within a building to change the circulation of the air.
- Locate sensitive objects away from spotlights, windows, exterior walls, air vents, and entrance doorways. You can also limit increased temperatures caused by the sun by using existing blinds, curtains, drapes, or exterior shutters.
- In temperate zones, reduce temperature levels during the winter. Lowering the set point of the heating equipment by several degrees raises the interior relative humidity to stabilize conditions overall. **Note:** Gradually reduce the temperature over a period of weeks. In the spring, gradually raise the temperature back to the appropriate set point. See the next section for a more in-depth discussion of humidistatic control.
- Store objects in cases, boxes, and folders. Containers are a very effective method of buffering temperature and RH fluctuations. They also limit light damage and protect collections from pests.
- To control relative humidity levels for sensitive objects (for example, some metals, textiles, paper, pyritic mineral, and fossil specimens) you may need to create a microenvironment to stabilize and maintain conditions that are different from the general museum environment. The use of a properly sealed storage cabinet or exhibit case with buffering material (for example silica gel) can provide a proper microclimate for sensitive objects. Refer to *Conserve O Gram* 1/8, “Using Silica Gel in Microenvironments” for guidance on using silica gel. There are a variety of other materials that can be used to produce microenvironments for storage of particularly sensitive objects. Consult with a conservator to discuss various options for your particular problem.
- Many materials in a museum environment absorb water and give off water. This slows changes in RH and *buffers* the environment around the object. Damage can be limited by slowing down RH changes. Natural organic materials (wood, textiles, cotton, and paper) are especially good at buffering. You can use this property to help limit changes in an environment. For example, when packing objects for shipping, wrap them in layers of paper and use pads of paper to fill the box and limit RH changes.

Active methods of control. A properly designed heating, ventilation and air conditioning (HVAC) system can maintain appropriate levels of relative humidity and temperature and filter particulate gases from the air.² Installing an HVAC system that achieves and maintains the environment to the levels described in this chapter is not easy. In some cases, especially with historic buildings, this approach can be detrimental to the historic building. Before embarking on a program to install, upgrade, or design a new HVAC system, assemble a team of experts and plan a system that protects both the collections and the museum building. Choose team

members with expertise in historic collections care, preservation, mechanical, electrical, and structural engineering.

You must have good information from your ongoing monitoring program to help you identify the needs and problems of your current system. Working from this information, your team can design a practical system that will preserve both the collection and the building.

In some cases, you may choose to use portable humidifiers, dehumidifiers, heaters, and air conditioners. In the short-term this equipment can do a lot to improve the environment in a museum collection space. It is also less expensive than installing a new HVAC system. Refer to the NPS *Tools of the Trade* for sources of equipment.

- **Humidifiers** quickly add moisture to the air. Use a humidifier in the winter to counteract the drying effect of a central heating system. Use only an unheated evaporative humidifier. This type of humidifier does not disperse minerals in the air, and if the humidistat (a switch that turns off the equipment when a certain RH is reached) malfunctions, this type of humidifier will not raise the RH level above 65-70%. Be sure air is well circulated. You may have to use fans for circulation. You must select the size and number of humidifiers based on the size of the space, the air exchange rate, differences between the inside and outside of the building, and the number of people using the room. The *Humidification Handbook*³ listed in the bibliography provides useful information about humidification.
- **Dehumidifiers** remove moisture from the air and lower the RH. Don't use this equipment as a permanent corrective measure – instead, find out why the air is so damp and work to remove the source of the water. There are two types of dehumidifiers:
 - Refrigerant dehumidifiers work on the same principle as a refrigerator. Cool air cannot hold as much moisture as warm air and it condenses within the machine. Use this type of dehumidifier in warm climates. You must drain dehumidifiers at least daily.
 - Desiccant dehumidifiers force air through a moisture-absorbing material (for example, lithium chloride) to reduce moisture. Hot air is blown over the desiccant to regenerate it. Desiccant dehumidifiers are useful in colder areas where refrigerant dehumidifiers may ice up and stop working.

The *Cargocaire Dehumidification Handbook* is a basic sourcebook for understanding dehumidification.⁴

9. *What are humidistatically controlled heating and ventilation systems?*

Humidistatic control is a way to control relative humidity in a building without using a HVAC system. The basic idea behind humidistatic control takes advantage of the inverse relationship between temperature and relative humidity.

Humidistatically controlled heating is based on the idea that if the absolute humidity of a given volume of air changes, it is possible to maintain a stable RH by manipulating and varying the temperature. A humidistat

sensor adjusts the temperature up and down to maintain a stable RH. If the RH rises above a set point, the heat is turned on until the RH drops back down. However, using this system, temperatures can drop very low, so this type of environmental control system is best used in areas that are infrequently accessed.

Humidistatically controlled ventilation is used in areas with high relative humidity. If interior RH is lower than exterior RH, dampers are opened by sensors and the air is circulated through the building. If exterior RH is too high, the dampers remain closed.

Both of these techniques may be cost effective ways of improving the environment in historic buildings that were not built to house museum collections. They are generally less intrusive to the building fabric, and maintenance and energy costs are lower than typical HVAC systems. If you are considering using humidistatic controls work with an engineer or architect who has experience with the technique.

10. *What is the time-weighted preservation index (TWPI)?*

The time-weighted preservation index is a mathematical model developed to estimate how long some organic materials will last at certain temperature and RH levels. Using the TWPI you can make educated decisions choosing a setpoint for RH and temperature in your collection.

The TWPI was developed specifically for paper-based collections and is more commonly used for archives and libraries. It may not be appropriate for mixed collections found in many NPS parks, though its use in various types of collections is being actively researched. However, you can use it to develop microenvironments, or separate storage rooms for your paper and photo collections. See the reference by James Reilly et al. (1995) for a complete discussion of the TWPI.

F. Light

Light is another agent of deterioration that can cause damage to museum objects. Light causes fading, darkening, yellowing, embrittlement, stiffening, and a host of other chemical and physical changes. This section gives an overview of the nature of light. It will help you understand and interpret monitoring data and the standards given for light levels in museum storage and exhibits.

Be aware of the types of objects that are particularly sensitive to light damage including: book covers, inks, feathers, furs, leather and skins, paper, photographs, textiles, watercolors, and wooden furniture.

1. *What is light?*

Light is a form of energy that stimulates our sense of vision. This energy has both electrical and magnetic properties, so it known as electromagnetic radiation. To help visualize this energy, imagine a stone dropped in a pond. The energy from that stone causes the water to flow out in waves. Light acts the same way. We can measure the “wavelength” (the length from the top of each wave to the next) to measure the energy of the light. The unit of measurement is the nanometer (1 nanometer (nm) equals 1 thousand millionth of a meter). We can divide the spectrum of electromagnetic radiation into parts based on the wavelength. The ultraviolet (UV) has very short wavelengths (300-400 nm) and high energy. We cannot perceive UV

light. The visible portion of the spectrum has longer wavelengths (400-760 nm) and our eyes can see this light. Infrared (IR) wavelengths start at about 760 nm. We perceive IR as heat.

The energy in light reacts with the molecules in objects causing physical and chemical changes. Because humans only need the visible portion of the spectrum to see, you can limit the amount of energy that contacts objects by excluding UV and IR radiation that reaches objects from light sources.

All types of lighting in museums (daylight, fluorescent lamps, incandescent (tungsten), and tungsten-halogen lamps) emit varying degrees of UV radiation. This radiation (which has the most energy) is the most damaging to museum objects. Equipment, materials, and techniques now exist to block all UV. No UV should be allowed in museum exhibit and storage spaces.

The strength of visible light is referred to as the *illumination level* or *illuminance*. You measure illuminance in *lux*, the amount of light flowing out from a source that reaches and falls on one square meter. We measure illuminance in museums because we are concerned with the light energy that falls on our objects, not how much light energy comes from the source. When you measure light levels (see Section H), hold your meter at the surface of the object to catch the light that is reaching that surface.

Illuminance was previously measured in *footcandles*. You may find older equipment or references that list footcandle levels. Ten footcandles equal about 1 lux.

When considering light levels in your museum you should keep in mind the “reciprocity law.”

The reciprocity law states, “Low light levels for extended periods cause as much damage as high light levels for brief periods.”

The rate of damage is directly proportional to the illumination level multiplied by the time of exposure. A 200-watt light bulb causes twice as much damage as a 100-watt bulb in the same amount of time. A dyed textile on exhibit for six months will fade about half as much as it would if left on exhibit for one year. So if you want to limit damage from light you have two options:

- reduce the amount of light
- reduce the exposure time

Note: Even small amounts of light will cause damage. Damage as a result of exposure to light is cumulative. It cannot be reversed. However, you can stop the continuation of damage by placing an object in dark storage. Cases, boxes, and folders are the first defense against light damage.

If lighting is too close to or focussed on an object, IR can raise the temperature. It may also lower the water content of porous materials. You can get heat buildup from:

- sunlight
- incandescent spotlights
- fluorescent ballasts
- lights in closed cases

Design exhibits so there is no heat buildup from IR generated by lights.

2. *What are the standards for visible light levels?*

You can protect your exhibits from damage caused by lighting by keeping the artificial light levels low. The human eye can adapt to a wide variety of lighting levels, so a low light level should pose no visibility problems. However, the eye requires time to adjust when moving from a bright area to a more dimly lighted space. This is particularly apparent when moving from daylight into a darker exhibit area. When developing exhibit spaces, gradually decrease lighting from the entrance so visitors' eyes have time to adjust. Do not display objects that are sensitive to light near windows or outside doors.

See the next section for ideas on how to control visible, UV, and IR light.

Basic standards⁵ for exhibit light levels are:

- **50 lux maximum** for especially light-sensitive materials including:
 - dyed organic materials
 - textiles
 - watercolors
 - photographs and blueprints
 - tapestries
 - prints and drawings
 - manuscripts
 - leather
 - wallpapers
 - biological specimens
 - fur
 - feathers
- **200 lux maximum** for less light-sensitive objects including:
 - undyed organic materials

- oil and tempera paintings
- finished wooden surfaces
- **300 lux** for other materials that are not light-sensitive including:
 - metals
 - stone
 - ceramics
 - some glass

In general don't use levels above 300 lux in your exhibit space so that light level variation between exhibit spaces is not too great. With this method, people's eyes will not have to keep adapting to changing light levels, and they will be able to see objects exhibited at lower levels much more easily.

These standards should serve as a starting point for developing lighting standards for your collections. In order for collections to be seen and used in various ways (for example, long-term exhibit, short-term exhibit, research, teaching) you should take into account a variety of factors:

- light sensitivity of the object
- time of exposure
- light level
- type of use
- color and contrast of object

For example, if a researcher needs to examine fine detail in the weave of a textile, but will only be working on the object for one day you should allow more light (up to 1350 lux) than if the same textile were going on exhibit for two years.

Note: These light levels are a compromise between the need to see exhibits and the need to preserve the objects. All light exposure will cause damage to sensitive objects. There is no minimum level where damage will not occur.

See references in the bibliography for more information on light and designing appropriate lighting for your exhibit and storage areas.

G. Monitoring and Controlling Light

To be sure that light levels are at required levels and to be sure that any UV filtering material is still effective, you should measure light levels at least once a year. If you change lighting fixtures, take new measurements to be sure the changes are within recommended levels. If the source of light is daylight (for example, in a historic house museum) you should measure light in the morning and afternoon throughout the seasons.

1. *How do I monitor light levels?*

You monitor light levels using specialized equipment. This equipment is necessary because your eye is not a reliable guide as it easily adapts to changes in visible light and can't see UV or IR light. Use a visible light meter to measure visible light and a UV meter to measure ultraviolet light. Use a thermometer to measure heat buildup from IR. Several different meters are available for measuring visible and UV light. See *NPS Tools of the Trade* for sources for light monitoring equipment.

- **Visible Light Meter:** Use a visible light meter to measure the visible portion of the electro magnetic spectrum. If you purchase a new meter, you should be sure to purchase one that measures in the standard unit, lux. The meter you choose should be sensitive enough to measure light levels as low as 25 to 50 lux with a reasonable degree of accuracy (10% or better).
- **Ultraviolet Meter:** The Crawford UV Monitor is the standard piece of equipment used in museums for measuring UV levels. This monitor gives UV readings in microwatts per lumen. Older models depended on adjusting a knob until one red indicator light jumped to another light, giving a fairly inaccurate measure. Newer models are more accurate, providing the reading on a direct analog scale. There are also models of UV meters from different manufacturers that will provide a digital readout.

Use a standard set of procedures when monitoring light levels with either piece of equipment. Aim the sensor toward the light source so you are catching the light that is hitting the object you are monitoring. Be sure no shadows from your hand or body are in the way. Make sure the sensor is parallel to the surface of the object and aimed toward the light source. If the object is larger than about one foot square, take several readings. Before using any equipment, carefully read the manufacturer's instructions for operation and maintenance.

2. *How do I improve the lighting to minimize damage to objects on exhibit or in storage?*

You should develop a plan of action first, to determine if a lighting problem exists, then to determine the cause, and solutions to correct the problem. To develop your plan you first need to collect information, evaluate the data, and then develop solutions to problems that you find.

Obtain and record the following information:

- types of existing lighting fixtures, ballasts, and filters
- movement of sunlight in the room throughout the day

- seasonal variations in light
- unusual events that occur (for example, filming in a historic structure, drapes removed for cleaning)

Once you have identified the types of light and variations in lighting, you need to evaluate how light may affect the objects. Identify museum objects that are most susceptible to light damage and establish monitoring sites nearby. You will use these same sites for each monitoring session. Abandon old sites and establish new ones as conditions change. Document your monitoring and any corrective actions that you take:

- Prepare a floor plan for each exhibit or storage space that indicates the location of each monitoring site.
- Record data on the Light and Heat Measurement Record illustrated in Figure 4.8.
- Note any corrective actions taken in the comments section, for example:
 - curtains drawn
 - historic awnings replaced
 - UV filtering film installed over windows or fluorescent tubes
 - electric voltage stepped down
 - light fixtures replaced
 - new procedures to turn off lights when room is not in use

3. *How do I limit light damage from research use?*

When historic objects, archival materials, and natural history specimens are used by researchers they are exposed to light. Set up separate work spaces and research rooms so that your entire collection is not exposed to light when people are working with individual objects. Incorporate the following practices into research room use to limit the damage that occurs from this use.

- Develop procedures so that collection items are exposed to light only while the researcher is using them.
 - Keep documents in boxes or folders.
 - Remove objects from cabinets only when the researcher is ready to work.
- Limit the number of times an individual document can be photocopied.

See *Museum Handbook*, Part III, Appendix D: Planning a Research Space, and *Conserve O Gram* 19/7, “Archives: Reference Photocopying,” and 4/14, “Planning a Research Space,” for more information on limiting light damage from collection use.

Evaluate the data you collect using the Light and Heat Measurement Record. Look carefully at the information and use it to decide how to minimize the damage from light. You may want to consult the regional/SO curator and/or a conservator for help with your evaluation. Think about the following:

- Which areas have acceptable levels of light for the objects? How long have objects been on exhibit in these areas? Do they show signs of damage? Remember, not all damage can be detected by visual inspection.
- Which areas have light levels that are too high? You will need to make changes in these areas and evaluate whether your changes have helped. For example, if UV filtering film is installed on glass window panes, monitor for UV before and after application. Has the UV been eliminated? Has it affected visible light? Does the visible light still exceed the standard?
- Compare existing light levels with historic lighting conditions. Do objects on exhibit receive more or less light than they did historically? Will reducing light levels in a historic structure improve the interpretation of the building and the collection, and at the same time improve preservation?
- How often are collections used? Where and how are they used? What levels and duration of light exposure do they normally receive? Can you reduce light levels in research rooms to improve preservation and still provide adequate access?
- How often are archival collections copied? Can you produce a 'duplication master' so that originals will not have to be continuously copied?

You should keep the data you collect. It can help you make a case for needed changes in lighting or removal of threatened objects. Keep a permanent file of all light monitoring data.

4. *How do I fill out the Light and Heat Measurement Record?*

Follow these instructions for filling out the Light and Heat Measurement Record shown in Figure 4.8. You should use building floor plans in conjunction with this record.

- Identify the park and structure in the appropriate blocks.
- Enter the day, month, and year, and the time of day in the appropriate blocks.
- On the building floor plan enter a number at a light measurement site. Enter this station number on the Record in the Location block.
- Record the ultraviolet light reading from the UV meter. If the reading is above 75 microwatts per lumen, you should take corrective action.

- Record the visible light reading from the visible light meter in the Lux block. If you are using a meter that records in footcandles, convert to lux by multiplying by 10 (1 footcandle = approx. 10 lux).
- Record the temperature in the Temperature block.
- Record any information about the type of light source, the weather, and other comments in the comments box. Record any unusual circumstances in this block.

NATIONAL PARK SERVICE					
LIGHT AND HEAT MEASUREMENT RECORD					
Structure: <i>Historic Exhibit Building</i>					
Date	Time	Location	UV Reading ($\mu\text{w}/\text{lumen}$)	LUX Reading	Room Temp.
4/11/99	11:00	Dining Room table in front of bay window	10	100	68
Comments: Cloudy day, drapes open					
5/10/99	11:30	Same as above	10	75	70
Comments: Bright hot day, drapes closed					
6/11/99	1:30	Same as above	100	100	68
Comments: UV filtering film is peeling in one corner of window, cloudy day, drapes open					
Comments:					
Comments:					
Comments:					
Comments:					
Comments:					
Comments:					

Figure 4.8. Example Light and Heat Measurement Record

5. *Is there any way to directly monitor light damage?*

You can directly monitor light damage by using Blue Wool light standards. Blue Wool light standards are specially dyed textiles made so that the most sensitive sample fades in half the time needed to fade the next most sensitive sample. There are eight samples to a set. You can use the Blue Wool standards in two ways:

- Place one set of standards at the place you want to measure. Place another set in total darkness.
- Place aluminum foil over one half of a set of standards.

By comparing the two sets of standards, or two halves of one set, you can determine the light fastness of a material. The standards will not help you estimate how much exposure to light a material will stand in a particular situation. You can use Blue Wool standards to help you make an argument that light damage is occurring and that changes are needed to protect museum objects.

6. *How do I control light levels?*

All light causes damage and the damage is cumulative. Therefore, you must control all light in museum spaces that contain museum objects. There are several control methods that you can use. Be creative and use a variety of strategies to minimize light. Always monitor before and after to be sure that your changes have really helped. Remember, your eye is not a good tool for measuring light levels—use monitors.

Visible light must be maintained at or below the recommended levels. You can obtain these levels using any of the control methods below:

- Use window coverings such as blinds, shades, curtains, shutters, and exterior awnings. Close window coverings as much as possible to prevent light from reaching museum spaces. If windows must be uncovered for visitors, install UV filters and work out schedules so that windows are uncovered for only part of each day.
- Use opaque dust covers (for example, cotton muslin or Gortex®) to cover light-sensitive objects, including floor coverings. Dust covers should be used whenever visitors are not present for extended periods. They are useful in storage areas and exhibit areas that are not open to the public for part of the year.
- You can use tinted light filters (for example, films or glazing) on windows or over artificial lighting. Don't use reflective films or tints that call attention to the windows or are historically inappropriate. Consult the park or regional historic architect and your regional/SO curator to be sure filters are appropriate.
- You can reduce the amount of light from fixtures by using colored filters, lowering the wattage of incandescent bulbs, using fewer fixtures, using flood light bulbs instead of spots, and turning off lights when people are not present. You can install motion detectors in exhibit areas that activate lighting only when a person is present. You can attach timers so that lights are on only for a specific period of time.
- Use incandescent lights (which produce very little UV) instead of fluorescent lights.

Ultraviolet light should be completely eliminated. All of the techniques used to limit visible light will also cut down on UV light. To block the remaining UV light:

- Install filtering material. Refer to NPS *Tools of the Trade* for sources of UV filtering material. Types of filters include:
 - UV filtering film for windows or glass on framed objects
 - UV filtering plexiglass instead of glass
 - filter sleeves for fluorescent tubes
 - UV filtered fluorescent tubes

The plastic material that carries the UV filtering coating often breaks down faster than the filtering chemical. You should replace filters whenever they begin to turn yellow or crack. Monitor UV radiation at least every five years to be sure the filtering material is still effective.

Infrared radiation (heat) generated by natural or artificial lighting should also be controlled to prevent rapid changes in relative humidity. Window coverings and filters and good air circulation systems (for example, fans and air conditioners) help control heat buildup. You can control the heat produced by artificial lighting fixtures by using filters and good air circulation systems, as well as keeping lights outside exhibit cases.

Floodlights used for professional and motion picture photography and photocopy machines can cause excessive heat buildup. Discourage photography in museum storage areas. When photography is allowed in museum areas request heat absorbing light filters and be sure the area is well-ventilated with fans or air conditioners. Lights should be turned off whenever filming is not taking place. If lighted rehearsals are necessary, use dummy objects until the final filming will take place.

H. Dust and Gaseous Air Pollution

Air pollution comes from contaminants produced outside and inside museums. Common pollutants include: dirt, which includes sharp silica crystals; grease, ash, and soot from industrial smoke; sulfur dioxide, hydrogen sulfide, and nitrogen dioxide from industrial pollution; formaldehyde, and formic and acetic acid from a wide variety of construction materials; ozone from photocopy machines and printers; and a wide variety of other materials that can damage museum collections. Air pollutants are divided into two types:

- **particulate pollutants** (for example, dirt, dust, soot, ash, molds, and fibers)
- **gaseous pollutants** (for example, sulphur dioxide, hydrogen sulphide, nitrogen dioxide, formaldehyde, ozone, formic and acetic acids)

1. *What are particulate air pollutants?*

Particulate pollutants are solid particles suspended in the air. Particulate matter comes both from outdoor and indoor sources. These particles are mainly dirt, dust, mold, pollen, and skin cells, though a variety of other materials are mixed in smaller amounts. The diameter of these pollutants is measured in microns (1/1,000,000 of a meter). Knowing the particulate size is important when you are determining the size of air filters to use in a building.

Some particles, such as silica, are abrasive. Pollen, mold and skin cells can be attractive to pests. Particulates are particularly dangerous because they can attract moisture and gaseous pollutants. Particulates can interact with gaseous pollutants and cause deterioration in three different ways. Particulates may be:

- a source for sulfates and nitrates (These particles readily become acidic on contact with moisture.)
- a catalyst for chemical formation of acids from gases
- an attractant for moisture and gaseous pollutants

2. *What are gaseous air pollutants?*

Gaseous pollutants are reactive chemicals that can attack museum objects. These pollutants come from both indoor and outdoor sources.

Outdoor pollutants are brought indoors through a structure's HVAC system or open windows. There are three main types of outdoor pollution:

- sulfur dioxide (SO₂), and hydrogen sulphide (H₂SO) produced by burning fossil fuels, sulfur bearing coal, and other organic materials
- nitrogen oxide (NO) and nitrogen dioxide (NO₂), produced by any kind of combustion, such as car exhaust as well as deteriorating nitrocellulose film, negatives, and objects
- ozone (O₃), produced by sunlight reacting with pollutants in the upper atmosphere and indoors by electric or light equipment, such as photocopy machines, printers, some air filtering equipment

When sulfur and nitrogen compounds combine with moisture and other contaminants in the air, sulfuric acid or nitric acid is produced. This acid then causes deterioration in a wide variety of objects. Ozone reacts directly with the objects causing deterioration.

The main sources of **indoor air pollution** come from building materials and include:

- wood, which can release acids
- plywood and particle board, which give off acids from wood and formaldehyde and acids from glues
- unsealed concrete, which releases minute alkaline particles

- some paints and varnishes, which release organic acids, peroxides, and organic solvents
- fabrics and carpeting with finishes, such as urea-formaldehyde, and wool fabrics that release sulfur compounds.
- glues, used to attach carpets, that can release formaldehyde
- plastics that release plasticizers and harmful degradation products such as phthalates and acids

Museum objects themselves may also contribute to indoor air pollution. For example, many plastics are inherently unstable and as they deteriorate they give off acidic by-products. Examples of sources of pollutants from museum objects include:

- celluloid and other unstable plastics used to produce many 20th-century objects
- cellulose nitrate and diacetate plastic, used for film
- pyroxylin impregnated cloth used for book bindings
- residual fumigants, such as ethylene oxide

<i>Object Materials</i>	<i>Deterioration</i>	<i>Primary Air Pollutants</i>	<i>Environmental Factors Accelerating Damage</i>
metals	corrosion/tarnishing	sulfur oxides and other acidic gases	water, oxygen, salts
stone	surface erosion, discoloration	sulfur oxides and other acidic gases, particulates	water, temperature fluctuations, salt, vibration, microorganisms, carbon dioxide
paint	surface erosion, discoloration	sulfur oxides, hydrogen sulfide, ozone, particulates	water, sunlight, microorganisms
textile dyes and pigments	fading, color change	nitrogen oxides, ozone	sunlight
textiles	weakened fibers, soiling	sulfur oxides, nitrogen oxides, particulates	water, sunlight, mechanical wear
paper	embrittlement	sulfur oxides	moisture, mechanical wear
leather	weakening, powdered surface	sulfur oxides	mechanical wear
ceramics	damaged surface	acid gases	moisture

Figure 4.9. Deterioration to Museum Objects Caused by Air Pollution

I. Monitoring and Controlling Particulate and Gaseous Air Pollution

As with problems from other agents of deterioration, you need to monitor your collections to identify whether or not air pollution is causing damage to your collections.

1. *How do I monitor air pollution?*

There are a variety of monitoring devices that can be used to directly measure pollutants in the museum. If you feel direct measurement is needed, contact your regional/SO curator for assistance. There are other steps you can take to identify and understand air pollution levels.

- Inspect storage spaces (for example, floors, open shelving, tops of cabinets and tables) for dust. Note how much dust has built-up since the last cleaning. Watch for increased insect activity using your IPM program. Increased insect activity is often related to an unacceptable accumulation of dust.
- In coastal areas, watch for pollution from chlorides by observing and noting active corrosion on metal objects. Chlorides will react with unpainted iron or steel objects, causing rust.
- Observe and document a building's air control system and the nature of the structure. Concrete walls and adobe are sources of high levels of dust. Some concrete dating from 1940-1975 contains asbestos, making it a health risk as well as a source of particulates. Improperly filtered air intakes can transfer high levels of pollutants into museum spaces.
- Identify exhibit cases, storage cabinets, and shelving made out of untreated wood or painted with the wrong paints that can outgas formaldehyde and acetic acid.
- Watch to see how much dust and dirt is tracked into spaces by visitors and employees.

Some parks have on-going air monitoring research. You can also contact the Environmental Protection Agency (EPA), Office of Air Quality Planning and Standards to obtain information on levels of ozone, sulfur dioxide, nitrogen dioxide, and particulates recorded in the park. These data will assist park staff in identifying potential pollutant problems that may exist. Areas with high concentrations of gaseous pollutants in the air will definitely want to establish a program for monitoring signs of active deterioration on objects in museum storage and exhibit areas.

2. *Are there ways to monitor for air pollution?*

There are several ways to monitor air pollutants that are simple to use in museums. Each has good points and bad points so before you choose one method, investigate each type of monitor and evaluate the type of information you want to recover. You can get advice from a conservator or your regional/SO curator. There is more information in the bibliography on using and evaluating monitoring devices.

Oddy tests: Oddy tests have been used for some time as a simple method of evaluating materials that are used in contact with objects in storage or on exhibit. In this test, metal coupons (small samples of metal) are placed in a closed container with the material being tested and a small amount of moisture. The container is slightly heated and after a set amount of time, the metal is examined for corrosion. It gives you some idea of how ‘safe’ a material is and whether or not it will cause deterioration? Problems with this test include:

- unusual reactions—because heat and moisture are raised in the container, reactions may occur that would not happen in a normal museum environment
- little reproducibility—for a variety of reasons, results from this test are widely variable

Passive sampling devices: These are devices that absorb particular pollutants. They are placed in the area you want to test for some period of time and then removed and sent to a lab to be tested for presence and levels of pollutants. Each passive sampling device measures one type of pollutant. For example, one device will measure for formaldehyde, another for acetic acid. However, there are problems with these devices:

- They may require off-site analysis.
- The devices have varying sensitivities. Use devices that can detect gaseous pollutant in parts per billion (1:1,000,000,000 ppb) or lower levels.

A-D strips. These strips detect acetic acid. They were developed to detect and measure acetate film deterioration or “vinegar syndrome” in film collections. They change color as the level of acidity increases. They are used to set priorities for film reformatting.

3. *How do I control air pollution?*

The NPS standard in the Checklist for Preservation and Protection of Museum Collections on controlling air pollution states, “Eliminate gaseous and particulate pollution to the lowest practical level.” There is no minimum acceptable level of pollution. You can do the following to reduce levels of air pollution:

- In storage spaces, keep floors, tops of cabinets, and work surfaces clean to minimize dust accumulation. Work with custodial staff to keep areas clean. Use high efficiency particulate air (HEPA) vacuums which catch more particulates. Regular vacuum cleaners simply throw many smaller particles up into the air.
- Separate office and curatorial work spaces from museum collections storage spaces. Areas that are not accessed often will stay cleaner than high traffic areas.
- Upgrade and maintain seals and weatherstripping around doors and windows to keep pollutants out.

- Store sensitive objects in appropriate museum specimen cabinets. Maintain sound gaskets on all storage cabinets. Replace old gaskets with neoprene gaskets. Refer to NPS *Tools of the Trade* for the source of retrofit gasket kits. NPS *Conserve O Gram 4/8* explains how to install the retrofit gasket kit.
- Store archival materials in boxes, map cases, and folders.
- Use dust covers to protect objects on open shelving. Dust cover material should be chemically and physically non-damaging and provide as complete a dust seal as possible, while allowing easy access. Use clear polyethylene sheeting, unbleached cotton muslin, Tyvek®, or Gore-Tex®. Refer to NPS *Conserve O Gram 4/7*, “Dust Covers for Steel Shelving,” for additional information on constructing dust covers.
- Segregate objects that outgas pollutants (for example cellulose nitrate negatives or objects, diacetate negatives, or hardwoods such as oak, birch or beechwood) from other objects.
- Store, exhibit, and transport objects in appropriate cases. Avoid using exhibit materials (for example, hardwoods) that outgas organic acids. The adhesives used in plywood and veneers may be a source of pollutants. See Figure 4.10 for a list of both harmful and safe materials.
- In areas with high air pollution levels you may want to install pollution filtering in your HVAC system. These filters extract gaseous and particulate pollutants before they get into a museum space. Work with HVAC engineers to design a system appropriate to your facility. Do not use filtering systems that generate damaging ozone.
- You can use portable air filters with activated-carbon filters to remove particulates from the air. These filters will also remove some gaseous pollutants. Refer to NPS *Tools of the Trade* for sources for this equipment.

Storage and Exhibit Construction Materials Known to Release Harmful Substances	
<i>Materials</i>	<i>Harmful Vapors</i>
wood (particularly oak, birch, beech)	organic acids
wood panel products	organic acids, formaldehyde
protein-based glues, wool	volatile sulfides
vulcanized rubber	volatile sulfides
some dyes	sulfur compounds
cellulose nitrate	nitrogen oxides
cellulose acetate	acetic acid
polyvinyl chloride	hydrogen chloride
polyurethanes	volatile additives
Storage and Exhibit Construction Materials That Appear to be Safe	
metals	
glass	
ceramics	
inorganic pigments	
polyethylene and polypropylene	
acrylic solutions (some acrylic emulsions are suspect)	
polyester fibers	
cotton and linen	

Note: while these materials are considered safe, manufacturing processes may add coatings and additives that can damage museum collections.

Figure 4.10. Types of Materials That Can Harm Objects and Types of Materials That are Considered Safe to Use with Museum Objects for Storage and Exhibit⁶

J. Selected Bibliography

- Adcock, Edward P., Marie-Therese Varlamoff, and Virginie Kremp. *IFLA Principles for the Care and Handling of Library Material*. Washington, D.C.: International Federation of Library Association and Institutions Core Programme On Preservation and Council on Library and Information Resources, 1998.
- Baer, Norbert S., and Paul N. Banks. "Indoor Air Pollution: Effects on Cultural and Historic Materials." *MM & C* 4: 9-22, 1985.
- _____. "Particulate Standards for Museums Libraries and Archives." In Air Pollution Control Association in Detroit, 1986.
- Brimblecombe, Peter. "The Composition of Museum Atmospheres." *Atmospheric Environment* 24B, no. 1 (1990): 1-8.
- Canadian Conservation Institute. "Ultraviolet Filters for Fluorescent Lamps." *CCI Notes* 2/1. Ottawa, Ontario: Canadian Conservation Institute, 1988.
- Carpenter, Jane, and Pamela Hatchfield. *Formaldehyde: How Great is the Danger to Museum Collections?* Cambridge, Mass.: Center for Conservation and Technical Studies, Harvard University Art Museums, 1987.
- Child, Robert E, ed. *Electronic Environmental Monitoring in Museums*. Denbigh, Clwyd, Wales: Archetype Publications Ltd., 1993.
- Cumberland, Donald C., Jr. "Dust Covers for Steel Shelving." *Conserve O Gram* 4/7. Washington, D.C.: National Park Service, 1985.
- _____. "Calibration of Hygrometers and Hygrothermographs." *Conserve O Gram* 3/16. Washington, D.C.: National Park Service, 1988.
- Cuttle, Christopher. "Damage to Museum Objects Due to Light Exposure." *CIBSE National Lighting Conference*, 1996.
- De Guichen, Gael. *Climate in Museums: Measurement*. 3d ed. Rome: International Center for the Study of the Preservation and Restoration of Cultural Property, 1988.
- Elovitz, Kenneth, ed. "Practical Guide to HVAC for Museums and Historic Renovation." *ASHRAE Journal* 41, no. 4 (1999): 48-98.
- Feller, Robert L. "Control of Deteriorating Effects of Light on Museum Objects: Heating Effects of Illumination by Incandescent Light." *Museum News* 46, no.9 (1968): 39-47.
- Grzywacz, Cecily M., and Norman H. Tennent. "Pollution Monitoring in Storage and Display Cabinets: Carbonyl Pollutant Levels in Relation to Artifact Deterioration." In *IIC Ottawa Congress: Preventive Conservation Practice, Theory, and Research*, pp. 164-170. Edited by Roy Ashok and Perry Smith. London: International Institute for Conservation of Historic and Artistic Works, 1994.
- Hackney, Stephen. "The Distribution of Gaseous Air Pollution within Museums." *Studies in Conservation* 29 (1984): 105-116.
- Hitchcock, Ann, and Gordon C. Jacoby. "Measurement of Relative Humidity in Museums at High Altitude." *Studies in Conservation* 25 (1980): 78-86.

- Jessup, Wendy Claire. "Conservation: A Basic Overview for the Exhibit Specialist." *Exhibitionist* (Summer 1990): 15019. Washington, D.C.: National Association for Museum Exhibition: Standing Professional Committee on Museum Exhibition of the American Association of Museums.
- La Fontaine, Raymond H., and Patricia A. Wood. "Fluorescent Lamps." *Technical Bulletin* No. 7. rev. ed. Ottawa, Canada: Canadian Conservation Institute, 1982.
- Lull, William P., and M. A. Garrison. "Planning and Design of Museum Storage Environments." *Registrar* 5, no. 2 (1988): 4-14.
- Michalski, Stefan. "Towards Specific Lighting Guidelines." *ICOM Committee for Conservation Preprints*, 1990.
- _____. "Temperature and Relative Humidity: The Definition of Correct/Incorrect Values." Technical Appendix. In Michalski, Stefan, *A Systematic Approach to the Conservation (Care) of Museum Collections*. Ottawa, Ontario: Canadian Conservation Institute, 1992.
- Padfield, Tim, David Erhardt, and Walter Hopwood. "Trouble in Store." In *Science and Technology in the Service of Conservation*, pp. 24-27, 1981.
- Park, Sharon C. "Heating, Ventilating, and Cooling Historic Buildings: Problems and Recommended Approaches." *Preservation Brief* 24. Washington, D.C. National Park Service, 1991.
- Raphael, Toby. *Exhibit Conservation Guidelines*. CD-ROM produced by Harpers Ferry Center. Harpers Ferry, W.V.: National Park Service, 1999.
- Reilly, James M. *The Storage Guide for Color Photographic Materials*. New York: The University of the State of New York, New York State Education Department, New York State Library, the New York State Program for the Conservation and Preservation of Library Research Materials, 1998.
- Reilly, James M., Douglas W. Nishimura, and Edward Zinn. *New Tools for Preservation: Assessing Long-term Environmental Effects on Library and Archives Collections*. Washington, D.C.: The Commission on Preservation and Access, 1995.
- Sheetz, Ron, and Charles E. Fisher. "Reducing Visible and Ultraviolet Light Damage to Interior Wood Finishes." *Preservation Tech Notes* 2. Washington, D.C.: National Park Service, 1990.
- Stolow, Nathan. "Chapter 2: Conservation Principles." In *Conservation and Exhibitions: Packing, Transport, Storage, and Environment Considerations*, pp. 4-24. London: Butterworths, 1987.
- Thomson, Garry. *The Museum Environment*. 2d ed. London: Butterworths, 1986.
- Thompson, John A., ed. *Manual of Curatorship*, 2d ed. London: Butterworths, 1992.
- Tétreault, Jean, and R. Scott Williams. *Materials for Exhibit, Storage, and Packing*. Technical Appendix in Michalski, Stefan. *A Systematic Approach to the Conservation (Care) of Museum Collections*. Ottawa, Ontario: Canadian Conservation Institute, 1992.
- Weintraub, Steven, and Gordon O. Anson. "Natural Light in Museum: An Asset or Threat?" *Progressive Architecture* 5 (May 1990): 49-54.
- _____. "Use Ultraviolet Filters to Neutralize an Invisible Enemy." *Museum News* 69 (1991): 85-87.

K. Endnotes

1. Relative humidity optimum ranges for materials included in Figure 4.2 are based on information from *Climate in Museums: Measurement* (3d ed.) by Gael De Guichen, and on information included in curatorial care appendices of this handbook.
2. *The ABCs of Air Conditioning: A Primer of Air Conditioning Types and Methods* outlines the types of air conditioning systems, introduces cooling load calculation, and compares the functioning of system types. A copy of this publication may be obtained from:

Carrier Air Conditioning
P.O. Box 4800
Syracuse, NY 13221
(315) 432-6000

3. *The Humidification Handbook: What, Why and How*, written by Bernard W. Morton, includes an introduction to humidity theory and measurement, and provides specification information on the determination of humidification load, methods of humidification, and system design considerations. It is available from:

Dri-Steem Humidifier Company
14949 Technology Drive
Eden Prairie, MN 55344
(800) 728-8336

4. *The Cargocaire Dehumidification Handbook* discusses methods of dehumidification, system design, and selection, and provides an introduction to calculations of moisture loads. A copy of this publication may be obtained from:

Cargocaire Engineering Corporation
79 Monroe Street
P.O. 640
Amesbury, MA 01913
(800) 843-5360

5. Illumination levels are based on information in *The Museum Environment* (2d ed.), "Light," Part I by Garry Thomson.
6. Information included in Figure 4.10 is taken from "Trouble in Store" by T. Padfield, D. Erhardt, and W. Hopwood, and "Materials for Exhibit, Storage, and Packing," by J. Tétreault and S. Williams.

Chapter 5: Biological Infestations

	<u>Page</u>
A. Overview	5:1
What information will I find in this chapter?	5:1
Who should read this chapter?	5:1
What is a museum pest?	5:1
B. Active Infestations	5:1
What do I do if I find live pests in the museum?	5:1
How do I stop an infestation?	5:2
C. Identification of Museum Pests	5:3
What are museum pests?	5:3
What are fabric pests?	5:4
What are wood pests?	5:5
What are stored product pests?	5:6
What are moisture pests?	5:6
What are General Pests (perimeter invaders)?	5:7
D. Integrated Pest Management (IPM)	5:7
What is Integrated Pest Management?	5:7
Why should I use IPM?	5:8
What types of damage can pesticides do to museum objects?	5:8
What are the components of an IPM Program?	5:9
E. Monitoring	5:9
Why should I monitor for pests and monitor the environment?	5:9
How do I know where to monitor?	5:10
What does pest damage look like?	5:10
How do I monitor for pests?	5:11
What kinds of traps should I use?	5:11
How do I establish an insect trapping program?	5:11
What actions should I take to keep pests out?	5:13
How do I know when I have a problem and must take some action?	5:14
F. Documenting and Evaluating Your IPM Program	5:14
How should I document my IPM program?	5:14
How do I know if the IPM strategy is effective?	5:14
Where can I find other information about IPM and Museum Pests?	5:14
G. Selected Bibliography	5:15
H. Web Information	5:15
List of Figures	
Figure 5.1 Sample Pest Identification Request Letter	5:16
Figure 5.2 Sample Museum Integrated Pest Management Survey Form	5:17

CHAPTER 5: BIOLOGICAL INFESTATIONS

A. Overview

- What information will I find in this chapter?*

This chapter contains information on:

 - pests that can damage museum collections
 - setting up an Integrated Pest Management (IPM) plan for museum collections
- Who should read this chapter?*

You should read this chapter if you are responsible for museum collections. You can use this chapter to develop a museum Integrated Pest Management Program yourself or to evaluate the need for IPM in your museum management strategy. IPM is an ecosystem approach to the control of pests. IPM uses a variety of techniques to prevent and solve pest problems so that pesticides are used only as a tool when other techniques will not work. Pesticides are any chemicals with an EPA registration number used to control pests of any type.
- What is a museum pest?*

A pest is an organism that jeopardizes museum resources. Dermestid beetles in a woolen rug are pests. Dermestid beetles in an animal carcass in the field are not.

B. Active Infestations

- What do I do if I find live pests in the museum?*

Follow these steps to stop an infestation and prevent it from recurring.

 - Don't panic. If you rush to kill the pests you may cause more harm to the artifact (and to yourself) than if you leave the pests alone for a short time. Be thoughtful about each step you take. Remove pests safely and set up a program to keep the infestation from recurring.
 - If an infestation is found on objects, isolate them immediately. Put the infested objects in a sealed plastic bag. Don't carry infested material through the collection without isolating it. You can drop eggs or larvae that can spread the infestation.
 - Identify the pests. You may find that insects you see are not museum pests. More information on pests and identification is included in Section C.
 - Determine the extent of the infestation. Start at the site where the first infested object was found and inspect the collections/areas in ever widening circles. Isolate infested materials as they are found and document the findings.
 - Determine the source of the infestation. If the problem is gaps in the building structure, collaborate with appropriate staff and make repairs to the building. If infested materials were brought into the collection,

evaluate and modify the policies and procedures that allowed this to happen. See Section E for more information on keeping pests out of museum collections.

- Develop a treatment strategy. Include the following steps:
 - Identify and document the pest and its development stage.
 - Identify the materials in the infested object.
- Based on these findings, answer the following questions:
 - Can you simply remove the pest?
 - Are eggs present?
 - What is the least damaging approach to treatment?
- There are a number of options for treatment described below. Only after you've considered all options should you treat the object.
- After treatment, clean the artifacts to remove dead pests and waste. Dead pests, larval skins, and nests can all attract new pests.
- Document the treatment. More information on documentation is included in section F.

2. *How do I stop an infestation?*

Use these methods to stop an infestation in objects:

- **Identification:** Identify the insect to be sure that it is a museum pest and will cause damage to museum objects. Section C has information on how to have pests identified.
- **Cleaning:** If an infestation is limited to a single object and has not progressed too far, careful vacuuming may remove the problem. Before cleaning, you should be sure the structure of the object can withstand the stress of vacuuming. Cleaning will probably not remove all eggs (some can be microscopic). Remove the vacuum bag from the building immediately so it doesn't become a source of new infestations. After cleaning, place the object in a plastic bag and isolate it from the rest of the collection. Determine the life cycle of the pest and monitor the object until you are sure no more insects will hatch.
- **Freezing:** Freezing has become the method of choice for treating most active infestations of individual objects and collections. See *Conserve O Gram 3/6, An Insect Pest Control Procedure: The Freezing Process*. Be aware that a few types of materials—lacquer, bone, painted surfaces, and some woods—can be significantly damaged by freezing. Organic and inorganic portions of composite objects will react differently and cracking may result. If you have a question about the safety of freezing an object, contact your Support Office (SO) curator or a conservator.

- **Anoxic Environments:** Replacing the air with a gas (nitrogen, argon, carbon dioxide) in a closed space can also kill insects and their eggs. A wide variety of techniques are used, some by museums, others by professional pest control companies. These techniques require special equipment and experience. For more information on anoxic environments and their use in pest control see *Conserve O Gram* 3/8, *Managing Insect Pests: Alternatives to Pesticides*, and the references listed at the end of this chapter.
- **Conventional Chemical Fumigation:** Fumigation is only appropriate if you cannot treat individual objects. It may be appropriate to fumigate a museum space. Vikane (sulfuryl fluoride) is now the only product available; all others have been banned. It is a restricted use pesticide that requires park and regional IPM approval before applications. Work with park and regional IPM coordinators to develop your IPM plan and make decisions about pesticide use.
 - Use of any pesticide requires at least regional approval.
 - Check with a SO curator or a conservator to be sure that the pesticide you choose will not harm collections.

C. Identification of Museum Pests

1. *What are museum pests?*

Museum pests are biological agents that can cause damage to museum collections. Insects, mold, mice, rats, birds, and bats are all museum pests. The damage pests do comes from feeding or nesting behavior or by attracting other types of pests. Pests that regularly damage museum collections can be roughly grouped as:

- fabric pests
- wood pests
- stored product pests
- moisture pests
- general pests

Identifying an insect and its life stage is critical in determining what is happening in the areas being monitored. This chapter gives only brief descriptions of some types of pests. Many other pests may be found. You should familiarize yourself with other resources. Refer to the NPS Integrated Pest Management Information Manual and other references at the end of the chapter. Good illustrations to help you identify pests can be found in the references by Zycherman and Schrock (1988) and Mallis (1982). To get help in identifying unknown pests, contact park and regional IPM coordinators, SO curators, or NPS Cooperative Park Study Units. You can also get assistance from entomologists in the cooperative

Extension Service, U.S. Forest Service, state departments of food and agriculture, and at local universities and natural history museums. See Figure 5.1 for a sample pest identification request letter.

You should also start your own reference collection of pests to compare to when identifying new pests that you trap. These insects can be stored on small squares cut from insect sticky traps (discussed below) and placed in small plastic boxes. You can also use small vials or boxes to store pests you find or trap using other methods.

2. What are fabric pests?

Fabric pests are protein eaters. The two main groups are carpet beetles (of the family Dermestidae) or clothes moths (of the family Tineidae). The larvae of these types of insects feed on animal products used in museum collections, such as wool, fur, feathers, and horns.

Carpet beetles are also commonly known as dermestids. Carpet beetle larvae cause damage by feeding on a wide variety of materials including fur, feathers, wool and silk cloth, wool felt, hair, study skins, and trophy mounts. They may not be seen because they hide from light, burrowing deep into artifacts. The larvae shed their skins as they grow and these skins are one of the signs of infestation to watch for. The adults are attracted to light and come out of hiding to mate. They may collect along windowsills. There are many species of carpet beetles, but the four described below are commonly found in museums. These beetles can be easily mistaken for other types of beetles that do not damage museum collections. Be sure to carefully identify the beetle before taking action.

- **Black carpet beetle** (*Attagenus unicolor*) is the most abundant and destructive of the carpet beetles. The adult is 1/8"- 3/16" long, a solid dark brown or dull black color, and more elongated than carpet beetles described below. The larva is less than 1/4" long and carrot-shaped. It is covered with golden brown hairs and has a characteristic "tail" of long hairs at the rear end.
- **Varied carpet beetle** (*Anthrenus verbasci*) is primarily a scavenger. It is common in the nests of birds, on dead animals, and in insect collections. It can damage woolens, carpets, wall hangings, hides, horns, and bone artifacts. Small populations often go unnoticed behind furniture or along baseboards, feeding on accumulated lint, hair, food crumbs, dead insects, and other organic debris. The adult is about 1/8" long, oval to round, blackish with splotches of white, yellow, and black on its back. The larva is 4-5 mm long, teardrop-shaped, and covered with rows of light brown hairs.
- **Common carpet beetle** (*Anthrenus scrophulariae*) attacks carpets, woolens, and animal products such as feathers, furs, leather, silks, mounted museum specimens, and pressed plants. The adult is about 1/8" long and black with white scales and a band of orange scales down the middle of its back. The larva is reddish-brown and covered with brown or black hairs. Larvae are active and move rapidly.
- **Furniture carpet beetle** (*Anthrenus flavipes*) attacks upholstery

(particularly old horsehair-stuffed furniture) and items made from wool, fur, feathers, silk, horns, and tortoise shell. The adult is about 1/8" long and is rounded and blackish with variable mottling of yellow and white scales on the back and yellow scales on the legs. The larva is difficult to distinguish from the common carpet beetle.

Clothes moths are small, silvery-beige moths with a wingspan of less than 1/2". They have narrow wings fringed with long hairs. Small grain- and flour-infesting moths are often confused with clothes moths, however, clothes moths have different flying habits. They avoid light and are rarely seen flying. They prefer dark corners, closets, and storage areas, and usually remain out of sight.

The primary food of clothes moth larvae is soiled woolens, but they also feed on silk, felt, fur, feathers, and hairs. In museums they often damage woolen clothes (particularly old military uniforms), feather hats, dolls and toys, bristle brushes, weavings, and wall hangings.

- The **webbing clothes moth** (*Tineola bisselliella*) and the **casemaking clothes moth** (*Tinea pellionella*) are the two most common clothes moths found in museums. The larvae are small white caterpillars with brown heads. They feed on the surface of the material infested. The webbing clothes moth produces feeding tunnels of silk and patches of silken webbing on the fabric's surface. The casemaking clothes moth is rarely seen since it constructs a cylindrical case of fabric that it carries around to hide and feed in. The color of the larval case will match the material on which it's feeding. Using this clue can help you locate infested materials.

3. *What are wood pests?*

Materials made of wood are susceptible to attack by a number of wood-infesting pests. The culprits in museums are usually woodboring beetles or drywood termites. Both can severely damage valuable artifacts while remaining invisible to the untrained eye.

Woodboring beetles are a group of beetles in the insect families Anobiidae (anobiid, furniture, and deathwatch beetles), Lyctidae (true powderpost beetles), and Bostrichidae (false powderpost beetles). The term "powderpost" comes from the fact that the larvae of these beetles feed on wood and, given enough time, can reduce it to a mass of fine powder.

Woodboring beetles spend months or years inside the wood in the larval stage. Their presence is only apparent when they emerge from the wood as adults, leaving pin hole openings, often called "shot holes," behind and piles of powdery frass (digested wood that looks somewhat like sawdust) below. Shot holes normally range in diameter from 1/32" to 1/8", depending on the species of beetle. If wood conditions are right, female beetles may lay their eggs and reinfest the wood, continuing the cycle for generations. Heavily infested wood becomes riddled with holes and tunnels packed with a dusty frass. Powderpost beetles can attack both hardwood and softwood, although lyctids only infest hardwoods.

Items in museums that can be infested by woodboring beetles include wooden artifacts, frames, furniture, tool handles, gunstocks, books, toys,

bamboo, flooring, and structural timbers.

Drywood termites, unlike their cousins the subterranean termites, establish colonies in dry, sound wood with low levels of moisture, and they do not require contact with the soil. They are primarily found in the coastal southern states, California, and Hawaii, but they are easily transported to northern states in lumber, furniture, and wooden artifacts. Drywood termites attack wooden items of all kinds. The termites feed across the grain of the wood, excavating chambers connected by small tunnels. The galleries feel sandpaper-smooth. Dry, six-sided fecal pellets are found in piles where they have been kicked out of the chambers. The pellets may also be found in spider webs or in the galleries themselves.

A swarming flight of winged reproductive termites can occur anytime from spring to fall. Most drywood termites swarm at night, often flying to lights.

4. *What are stored product pests?*

Many museums include items made in part of seeds, nuts, grains, spices, dried fruits and vegetables, and other foods. A long list of pests, traditionally called "stored product pests" or "pantry pests," can infest items containing these foods. Probably the most common of such pests in museums are the cigarette beetle and the drugstore beetle.

Cigarette beetle (*Lasioderma serricornis*) is named for the fact that it is a pest of stored tobacco, but is also a serious pest of flax, spices, crude drugs, seeds, and, most importantly for museums, books and dried plants. This beetle has been called the "herbarium beetle" because of the damage it can cause to dried herbarium specimens. It has also been found infesting rodent bait.

The adult beetle is light brown, 1/8" long, and the head is bent downward so that the beetle has a distinctive "hump-backed" look. It is a good flier. The small larva is grub-shaped and whitish, with long hairs that make it appear "fuzzy." It has yellow-brown markings on the head.

Drugstore beetle (*Stegobium paniceum*) feeds on a wide variety of foods and spices (particularly paprika or red pepper). It is also a serious pest of books and manuscripts, has been reported "feeding on a mummy," and has been known to chew through tin foil and lead sheeting.

The adult beetle is very similar to the cigarette beetle. With careful examination through a magnifying lens, the three-segmented antennal club may distinguish the drugstore beetle. The larva, too, is similar, but does not appear as "fuzzy."

5. *What are moisture pests?*

Not only is moisture a threat to museum specimens on its own, it may attract a number of moisture-loving pests that can do additional damage. Molds can be a big problem in damp conditions and can attract insects in the order Psocoptera that feed on those molds.

Molds are fungi that can cause damage or disintegration of organic matter. Basically plants without roots, stems, leaves, or chlorophyll, molds occur nearly everywhere. When moisture and other environmental conditions

are right, molds can appear and cause significant damage to wood, textiles, books, fabrics, insect specimens, and many other items in a collection. Their growth can be rapid under the right conditions.

It is important to realize that fungal spores, basically the "seeds" of the fungus, are practically everywhere. Whether molds attack suitable hosts in a museum depends almost exclusively on one factor—moisture. When moisture becomes a problem, molds will likely become a problem too.

For this reason museum objects should not be stored in humidity above 65%. Be aware, however, that some molds can grow at a lower humidity. **Psocids** are commonly called booklice, but they are not related to parasites such as head lice or body lice. They are referred to as booklice because they often infest damp, moldy books. They feed on the mold growing on paper and the starchy glue in the binding. Psocids also infest such items as dried plants in herbaria, insect collections, manuscripts, cardboard boxes, and furniture stuffed with flax, hemp, jute, or Spanish moss.

Psocids do not themselves cause damage. They become pests simply by their presence. However, their presence also indicates a moisture problem and the likely presence of damaging molds. They are tiny insects, less than 1/8" long, and range in color from clear to light gray or light brown. Most indoor psocids are wingless, looking a bit like a tiny termite.

6. *What are general pests (perimeter invaders)?*

Any household pest may become a pest in a museum. Many kinds of pests can get into a building that has not been well sealed. Cockroaches, crickets, silverfish, ants, millipedes, and other common pests can invade and infest a museum as well as a house or other structure. Mice, rats, birds and bats can also infest museum collections and buildings. They can cause direct damage to collections through nesting and feeding behavior. Their nests will also attract many other kinds of insects that can then move into the collections.

German cockroaches (*Blatella germanica*) are omnivorous. They are familiar as they are the most common cockroach found in the United States. They feed on leather, paper, glues, animal skins, and hair. Damage to objects is caused by chewing. They are especially attracted to objects stained with sweat. They can also stain objects by depositing various bodily fluids.

House crickets (*Acheta domesticus*) commonly come into buildings at the onset of cold weather. Like german cockroaches they are omnivorous and will eat protein and cellulosic materials. These include textiles (wool, silk, linen, cotton), leather, and animal skins and fur. They are especially attracted to stains.

Silverfish (*Lepisma saccharina*) and firebrats (*Thermobia domestica*) will eat fabrics, paper and sizing, and glue and paste in book bindings. They are omnivorous, so will eat protein materials as well as cellulose. They are especially damaging in dark, damp storage areas. They have a distinct carrot shaped body, short legs, long slender antennae, and three tail-like appendages.

D. Integrated Pest Management (IPM)

1. *What is Integrated Pest Management?*

Integrated Pest Management (IPM) is a decision-making process that helps you determine if, when, and where you need pest suppression. It helps you develop a strategy to keep pests from attacking collections. IPM uses a variety of techniques to prevent and solve pest problems using pesticides only as a last resort. It depends on knowledge of a pest's habits, ecology and the environment in which it thrives and survives. IPM is also site-specific and adaptable to any museum. It provides a structure in which to make responsible decisions about treating pests. Museum IPM has two goals:

- protect the museum and its collections from pests
- reduce the amount of pesticides used in collections

2. *Why should I use IPM?*

Pesticides can be health hazards for staff. Exposure to pesticides used incorrectly can cause acute symptoms such as nausea, vomiting, and breathing difficulty. Exposure can also cause chronic effects such as seizures, skin and eye irritation, and memory defects. Many pesticides are carcinogens or suspected carcinogens and human teratogens. For your own safety, as well as that of your offspring, visitors, and researchers, pesticide use should be carefully considered and only applied following label directions.

In 1980, a Presidential memorandum directed all federal agencies to adopt IPM in management policies. This memorandum and excerpts from Department of the Interior (DOI) and NPS policies on IPM are included in Appendix A. NPS-77, *Natural Resources Management Guideline*, provides guidance on pesticide use in the National Park Service.

3. *What types of damage can pesticides do to museum objects?*

Pesticides can cause the following damage:

- metal corrosion, including iron, brass, and other light color metals
- deterioration of proteins, such as fur, feathers, leather, wool, horsehair
- deterioration of paper
- shrinking, stiffening, or softening of plastics
- color change in dyes and pigments
- staining from surface and vapor contact

Museums have routinely used pesticides in collections for years. Many of these materials leave residues on museum artifacts. Search collection documentation for records of previous pesticide use. Be aware, however, that users often did not record pesticide use. Be sure to take precautions when handling the objects. See *Conserve O Grams 2/2-4* for information on the health and safety risks associated with some pesticides residues that are found on museum objects.

Many different types of pesticides have been used in museum collections. **None**

of these pesticides are now recommended for use. Pesticides that have been commonly used in museums include:

- arsenic (see *Conserve O Gram* 2/3)
- mercuric chloride
- thymol
- DDT
- ethylene oxide (see *Conserve O Gram* 2/2)
- dichlorvos (Vapona, DDVP) (see *Conserve O Gram* 2/4)
- naphthalene
- paradichlorobenzene (PDB)

4. *What are the components of an IPM Program?*

Each of these components is on-going and the whole process is cyclical in nature. To carry out an effective IPM program you should:

- ***Build consensus*** by working with other staff in the park. IPM requires coordinated strategies to be effective.
- ***Identify*** pests that can cause damage to your collections.
- ***Review NPS policy*** to understand how IPM works and your responsibilities when using chemical treatments.
- ***Establish priorities*** to focus on tasks in an organized fashion. For example, set up a monitoring program in areas of the collection that contain sensitive botanical specimens first.
- ***Establish action thresholds***. How many insects in a collection are too many?
- ***Monitor*** pests and environmental factors.
- ***Implement non-chemical management***. Modify pest habitats, use good housekeeping, and use non-chemical treatments such as freezing and anoxic environments.

If needed, review and obtain approval for an appropriate chemical pesticide. Treatments should only be done when pests have been found and identified. You must get approval from the regional IPM coordinator to use any pesticide in your park.

- ***Evaluate*** results to be sure your strategies are working.
- ***Document*** monitoring and treatments.

E. Monitoring

1. *Why should I monitor for pests and monitor the environment?*

Monitoring for pests and monitoring the environment provide you with different kinds of information.

Pest monitoring tells you . . .

Baseline information on the insects in your collection

How pests got into the museum

Where pests are in the museum

How many pests there are in the museum

If your control strategies are working

Environmental monitoring tells you . . .

Baseline information on your museum environment

If conditions will support pest activity

If your actions are changing the environment

Taken together, these two types of monitoring can help you determine strategies to eliminate future access and survival of pests in the collection. Monitoring can also help you evaluate the effectiveness of any treatment action you take. You can get more information on environmental monitoring in Chapter 4. It also provides information about environments that might help support an infestation.

2. *How do I know where to monitor?*

When developing a monitoring strategy, think about the resource that you are trying to protect and the kinds of pests that will cause damage to the resource. For example, will you expect mostly protein eaters because of lots of wool textiles? Are the collections in a historic, poorly sealed building with a damp basement?

Think through what kind of pests will be attracted to your collections. Also think about the kind of pests that will be supported in the environment in your building. Then aim your monitoring strategy to find out if those kinds of pests are present. Work with your park and regional IPM coordinators to develop a thoughtful strategy to identify pests for the collections in your park.

3. *What does pest damage look like?*

Different pests cause different types of damage. Evidence of pests includes:

- holes
- chewing marks
- hair loss
- webbing
- cast skins

4. How do I monitor for pests?

- “grazed” surfaces
- frass (insect waste, which is usually a soft powdery material)
- fecal pellets

Monitoring relies on a variety of techniques.

- **Routine inspection of objects:** Visually inspect the collection to look for cast larval skins, holes in textiles, piles of frass, cut hairs around and below artifacts. Do spot checks at least every six months; check more vulnerable objects like biological specimens and ethnographic objects more often.
- **Routine inspection of the building:** You must also routinely inspect the building to look for signs of insects that may get into your collections. Check windowsills and door jams especially carefully.
- **Trapping:** Identify pests moving into and throughout the building. Using traps allows you to “zero in” on problem areas where pests may be getting into a building, or where you have infested collections.
- **Documentation:** Document your inspection and trapping program carefully so that you have a record of problems that can be evaluated over time.

See *Conserve O Gram 3/7*, Monitoring Insect Pests with Sticky Traps, for more information on using a monitoring program.

5. What kinds of traps should I use?

There are three main types of insect traps. Use them in combination. Decide which kind of trap is most appropriate for a particular place and for the problem you have.

- **“Sticky traps”** collect bugs on an adhesive base. They are sometimes known as roach motels and come in a box or tent shape. They are available from a wide variety of manufacturers. For general purpose the tent shaped traps are the best. Replace them regularly as the adhesive will dry out and become ineffective. *Conserve O Gram 3/7* and *NPS Tools of the Trade* have information on sticky traps.
- **Pheromone traps** are usually sticky traps that include a pheromone attractant specific to one species of insect. These are only available for webbing clothes moths, drug store beetles, cigarette beetles, and the German cockroach, but more are being developed. See *Conserve O Gram 3/7*.
- **Light traps** are useful for detecting and controlling flying insects. They emit ultraviolet light (black light) that attracts flying insects, particularly flies and moths. The insects are drawn toward the light and trapped by a glue board or in a bag. Windows also act as passive light traps so windowsills should also be carefully monitored.

6. How do I establish an

Step 1. Draw a floor plan of the area you wish to monitor. Indicate the

insect trapping program?

locations of doors, windows, water and heat sources, and drains. Also include furnishings in the room, such as museum exhibit and storage cabinets and cases. Note what types of materials are stored in the cases.

Step 2. Number and date the tops of the traps for quick identification.

Step 3. Place traps throughout the area to be monitored. Keep in mind that pests like dark, warm, damp places. Where possible place the trap against the wall, as pests tend to move along this surface. Critical areas where pests are likely to be found include:

- along the perimeter walls
- in corners
- near doors
- near windows and other light sources
- under furniture
- near water sources
- near drains
- near heat sources
- inside and outside exhibit and storage cabinets

Step 4. Indicate the location of the traps on the floor plan.

Step 5. Inspect the traps on a regular schedule and record:

- the trap number
- the location of the trap
- the date inspected
- the species of insects
- the number of individuals per species found in the trap
- other useful information, including the life stage of the species, unusual conditions, and replacement date for the trap

You may devise your own survey form. See Figure 5.2 for a sample. Many museums document their pests with a simple computer spreadsheet or database program. During the initial phase of the monitoring period—usually the first three to six months—inspect the traps weekly. This will allow you to identify current problems and solve them quickly. Long-term monitoring will catch problems that develop later on and variations you

may see in different seasons of the year.

Refine the trap placement, as trapping becomes routine. Based on the evidence you find in the traps, you may want to move traps or inspect more or less often. However, don't wait too long to inspect traps, as dead insects are a food source that may attract other pests. With careful placement of traps you will be able to identify problem areas precisely.

Replace traps at least every two months, when they become full, or when the adhesive loses its tackiness—whichever comes first.

7. *What actions should I take to keep pests out?*

Cultural controls and mechanical controls are two basic types of actions you can use to prevent insects from getting into and thriving in your collection. Cultural controls are policies and procedures that you can implement. Mechanical controls are techniques to limit pest habitats and close off areas where pests get into the building.

Cultural controls include:

- inspecting any material (new accessions, loans, storage material) before it comes into collections areas
- developing good housekeeping and interior maintenance programs
- restricting food and smoking in the museum
- barring live and dried plants inside and eliminating plants and mulch next to the building
- developing environmental controls for a stable, low humidity
- putting objects into closed storage and exhibit cases whenever possible

Mechanical controls include:

- installing self-closing devices, sweeps and gaskets on exterior doors
- installing screening on floor drains
- removing ivy and plants growing on the structure
- cleaning gutters regularly
- closing windows and installing 20 mesh screening
- eliminating clutter, including cardboard, which is very attractive to insects
- minimizing dust
- using a vacuum cleaner instead of a broom to clean floors and structures

- caulking or otherwise blocking all holes in the building structure
- using sodium vapor lighting, which is less attractive to insects, for exterior fixtures

8. *How do I know when I have a problem and must take some action?*

Set a **threshold**. A threshold is the point at which you will take some action to remove or prevent the pest. Decide how many pests you must see or trap in an area before taking action. The action will usually not be a pesticide treatment. Establishing a regular vacuuming program is also an action.

The threshold is site-specific for each museum. For example, finding one insect near the door may not warrant action, but it does warrant increased vigilance. Finding an insect in a closed cabinet warrants action. You can expect to trap more insects in historic buildings than in new visitor centers. Decide on your thresholds before you start a monitoring program.

See information in Section A of this chapter for dealing with an active infestation.

F. Documenting and Evaluating Your IPM Program

1. *How should I document my IPM program?*

Use the IPM survey forms described in Section D and Figure 5.2 to document the monitoring. You can also develop your own spreadsheet or database. Use environmental monitoring forms in Chapter 4 to document the environmental monitoring that is done.

Document treatments done to objects (fumigation, freezing, cleaning). Record the treatment for each object in ANCS+ in the Preservation supplemental record. You can also file the information in the appropriate accession file or catalog folder, as outlined in the *NPS Museum Handbook*, Part II, Chapters 2 and 3. Be sure to include the brand name of insecticides and fumigants and the chemical name if known.

2. *How do I know if the IPM strategy is effective?*

Regularly evaluate your strategy. Analyze your survey forms. Are you seeing fewer pests in your traps? Have you stopped infestations?

If your strategy is working, all your time will be spent on prevention and maintenance and none on dealing with live pests and infestations in the collections.

3. *Where can I find other information about IPM and museum pests?*

Work with your park IPM coordinator. A regional IPM coordinator reviews applications for pesticide use. The regional IPM coordinator and the SO curator can help you develop IPM plans and strategies when you discover an infestation. The Associate Director, Natural Resources, and regional offices develop training in IPM. Some of the information contained in this chapter came from a National Park Service website *The NPS Integrated Pest Management Manual* <<http://www.colostate.edu/Depts/IPM/natparks/natpark.html>>. You can find more information there.

G. Selected Bibliography

- Dawson, John. "The Effects of Insecticides on Museum Artifacts and Materials." In *A Guide to Museum Pest Control*, edited by Lynda A. Zycherman and J. Richard Schrock, 135-150. Washington, D.C.: Association of Systematics Collections, 1988.
- Dawson, John, and Thomas J.K. Strang. "Solving Museum Insect Problems: Chemical Control." *Technical Bulletin* 15 (1992). Ottawa: Canadian Conservation Institute.
- Ebeling, Walter. *Urban Entomology*. Berkeley: University of California, Division of Agricultural Sciences, 1992.
- Florian, Mary-Lou. "Freezing for Museum Insect Pest Eradication." *Collection Forum* 6 (1990): 1-7, Washington, D.C.: Society for the Preservation of Natural History Collections.
- Mallis, Arnold. *Handbook of Pest Control*. Sixth Edition. Cleveland: Franzak and Foster, 1982.
- Pinniger, David B. *Insect Pests in Museums*. London: Archetype, 1991.
- Rust, Michael K., Vinod Daniel, James R. Druzik, and Frank C. Preusser. *The Feasibility of Using Modified Atmospheres to Control Insect Pests in Museums*. Marian Del Rey, Calif.: Getty Conservation Institute, 1996.
- Williams, Stephen L., and Suzanne B. McLaren. "Modification of Storage Design to Mitigate Insect Problems." *Collection Forum* 6 (1990): 27-32, Washington, D.C.: Society for the Preservation of Natural History Collection.
- Zycherman, Lynda A., and Richard Schrock, eds. *A Guide to Museum Pest Control*. Washington, D.C.: Association of Systematics Collections, 1988.

H. Web Information

- The NPS Integrated Pest Management Manual: <<http://www.colostate.edu/Depts/IPM/natparks/natpark.html>>
- Pest Management: <<http://palimpsest.stanford.edu/bytopic/pest>>
- Radcliffe's IPM World Textbook: <<http://ipmworld.umn.edu>>
- Insects Limited, Inc. homepage: <<http://www.insectslimited.com>>

[Date]

Dr. Melissa Adams
West Virginia Department of Agriculture
100 1st Street
Charleston, WV 25305-0170

Dear Dr. Adams:

The enclosed insect samples were found during monthly pest monitoring at Chris Doe Homeplace. Will you please identify the insects circled in red in the enclosed sticky traps as specifically as possible? We are particularly interested in potential pests to museum objects. Please return the specimens to me so that I can refer to them in the future.

My address is: Mark Hayden
 National Park Service
 Chris Doe Homeplace
 P.O. Box 50
 Ridgely, WV 23456-0050

Thank you very much for your help.

Sincerely,

Mark Hayden
Curator

Figure 5.1. Sample Pest Identification Request Letter

**NATIONAL PARK SERVICE
MUSEUM INTEGRATED PEST MANAGEMENT SURVEY FORM**

Park: Chris Doe Homeplace

Date Trap Set: Oct. 1, 1998 Date Trap Inspected: Oct. 15, 1998

Structure Housing Museum Collection: Big Run Visitor Center Storage

Exhibit Space? Storage Space? X

Name and Title of Inspector: Mark Hayden, Curator

List number of each type of pest.

Trap number:	#1	#2	#3	#4	#5	#6	#7
Location:	ext. door	N. wall	NE corner	SE corner	int. door	floor drain	window
dermestid beetle			1 larva				
cigarette beetle							
drugstore beetle							
powderpost beetle							
clothes moth							
silverfish						3	
cockroach	1						
termite							
spider							1
fly							5
fungal growth							
mouse							
other: cricket	1						
other:							
undetermined							
Total pests:	2	0	1	0	0	3	6

Other unusual observances (e.g., puddles, unusual level of dust, etc.).

Debris on floor around exterior door.

Figure 5.2. Sample Museum Integrated Pest Management Survey Form

Chapter 6: Handling, Packing, and Shipping

A. Introduction	6:1
B. Handling Objects	6:2
Why are careful handling practices important?	6:2
Who needs to learn safe handling practices?	6:2
What basic practices can I use to safely handle and move objects in the museum?	6:2
How should I proceed with moving an object?	6:3
What are the basic rules for handling museum objects?	6:4
What is the best way to protect an object I must pick up?	6:6
When should I wear gloves?	6:6
What should I do if I damage an object?	6:6
What personal health and safety issues should I consider when handling museum objects?	6:7
C. Moving Objects Within the Museum	6:9
What should I do before moving objects within the museum?	6:9
What do I need to know before moving objects?	6:9
D. Packing and Shipping Preparations	6:11
When would I need to pack and ship objects?	6:11
Why is it important to properly pack objects for shipping?	6:11
How can I learn how to pack museum objects?	6:11
What kind of workspace do I need for packing?	6:11
How much time should I allow for packing objects?	6:12
What do I need to consider before shipping?	6:12
How do I determine if the object can be safely shipped?	6:12
How do I ship hazardous materials?	6:13
How should I document the condition of the objects?	6:13
E. Packing and Shipping Materials	6:13
Why is it important to use the right packing and shipping materials?	6:13
What sources of packing materials are available?	6:13
What are good covering and wrapping materials?	6:14
What are good cushioning materials?	6:15
What materials make good interior boxes?	6:15
What kind of tape should I use on the box and the wrapping material?	6:16
How should I select an exterior container?	6:16
What kinds of containers do I use for objects that have different weights and sizes?	6:17
Can I build an exterior container?	6:17
Can I use a reusable shipping container?	6:17
How do I protect objects from environmental changes during shipping?	6:17
How should I store packing materials?	6:17
F. Packing for Shipping	6:18
How do I decide which way to position an object in a container?	6:18
How do I cover and wrap an object?	6:18
How should I cushion the object inside the container?	6:19
What other techniques can I use to cushion objects and provide shock absorption?	6:20
What should I do before closing the container?	6:22
Should I wrap and label the shipping container?	6:22
What should I put on the label on the exterior of the container?	6:22
What kind of identification markings should I put on the box?	6:23

G. Shipping Objects	6:23
What things should I consider if I use a professional packer/shipper?	6:23
What transportation alternatives are available for shipping museum objects?.....	6:24
When should I use the U.S. Postal Service?	6:24
When should I use commercial package delivery services?	6:24
When should I use an art shuttle van or special product truck?	6:25
When should I use airfreight?	6:25
Should I use a courier?.....	6:25
H. Receiving and Unpacking the Container	6:26
How should I unpack a container?	6:26
Should I check for insect infestation?.....	6:27
What do I do if an object is damaged, lost, or destroyed during shipping?.....	6:27
I. Selected Bibliography	6:28

List of Figures

Figure 6.1. Proper Handling Techniques.....	6:1
Figure 6.2. Carts and Trays Minimize Handling.....	6:2
Figure 6.3. Equipment and Supplies	6:3
Figure 6.4. Hold Objects at the Strongest Point.....	6:5
Figure 6.5. Wear Gloves and Use Both Hands.....	6:6
Figure 6.6. How to Lift Properly and Avoid Injury.....	6:7
Figure 6.7. The Proper Way to Lift a Chair	6:8
Figure 6.8. The Proper Way to Lift a Small, Framed Photograph.....	6:8
Figure 6.9. The Proper Way to Lift and Carry a Small Textile Object	6:8
Figure 6.10. Use Trays and Padding to Prevent Damage.....	6:10
Figure 6.11. Pad and Separate Parts.....	6:19
Figure 6.12. Wrapping, Padding, and Packing for Shipping an Object.....	6:20
Figure 6.13. Objects Double-boxed for Shipping.	6:21
Figure 6.14. Example of Written Handling Rules for NPS Park Collections.....	6:30

CHAPTER 6: HANDLING, PACKING, AND SHIPPING

A. Introduction

This chapter outlines handling, packing, and shipping guidelines for safely moving museum objects. By following these guidelines, you can prevent damage to the objects in your museum collection. The chapter includes:

- basic practices to ensure object safety
- guidelines for handling objects
- guidelines for moving objects inside the museum
- materials and techniques to properly pack for shipping
- basic directions for shipping objects
- guidelines for unpacking an object
- bibliography of references on handling, packing, and shipping museum objects

Specific guidance for handling different types of objects can be found in the appendices of this volume for each object type.



Figure 6.1. Proper Handling Techniques.
Proper handling techniques are essential to museum housekeeping practices.

B. Handling Objects

When you touch, lift, or hold an object you are handling it. When you work in a museum you will have to handle objects for a variety of tasks. To do this safely and effectively it is important to learn and practice good handling techniques.

1. *Why are careful handling practices important?*

Preventive conservation starts with careful handling. Proper handling is largely a matter of common sense and is necessary for the care and protection of objects. However, good handling techniques are not always obvious. Museum procedures require specialized handling knowledge that must be learned. For example, metals can corrode after being handled without gloves. Paintings may crack as a result of bumping and jarring during movement. Mishandling can cause obvious examples of damage, such as shattered glass in a frame, broken ceramics, torn documents, or dents and scratches in metal objects.



Figure 6.2. Carts and Trays Minimize Handling.

The use of equipment and supplies such as carts and trays minimizes the need to handle objects.

2. *Who needs to learn safe handling practices?*

Anyone who handles museum objects needs to be aware of the guidelines in this chapter. If your day-to-day responsibilities require you to handle objects, you need to be sensitive to their delicate nature. Regular activities like cataloging, photographing, housekeeping, and packing for shipment all require you to handle and work with objects.

3. *What basic practices can I use to safely handle and move objects in the museum?*

Write guidelines.

Establish written guidelines to help foster a professional attitude and respect for objects. Provide **all** staff with a set of written guidelines. Post the guidelines in museum storage areas. Be sure that all staff who handle objects read the guidelines. Researchers who handle objects should read the guidelines when they first use the collections. Staff should read the guidelines when hired and review them periodically. See Figure 6.14 for an example of handling guidelines you can use.

Train your staff.

Don't handle museum objects without training. Training should be an on-going activity, particularly when new types of objects are being handled. Make "hands-on" experience a part of all training for individuals working with collections. Re-training reminds people of the importance of proper handling techniques. You should give a special training session whenever new staff members assist in handling objects.

Use proper supplies and equipment.

Only use equipment that is of good quality and in good condition. Equipment for moving objects includes flatbeds, carts, dollies, pallet lifters, polyethylene tote pans, and object support trays. The supplies you use with the equipment to move objects include polyethylene foam pads for lining carts and trays, quilted furniture pads, acid-free tissue, and clean cotton or plastic gloves. You may need to acquire personal protective equipment such as lab coats and smocks, safety glasses, dust masks, and personally fitted respirators. Supplies and equipment are listed in more detail below.

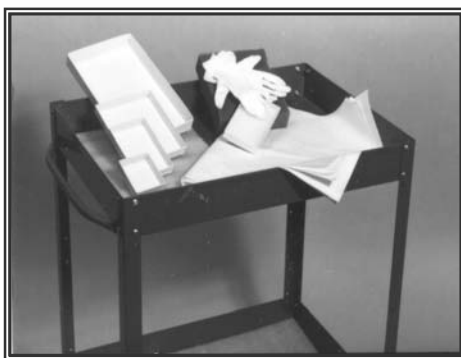

Figure 6.3. Equipment and Supplies.

Equipment and supplies for handling and moving museum objects include trays, padding, tissue, gloves, and carts.

4. *How should I proceed with moving an object?*

Consider safety first.

Before moving an object, inspect equipment to ensure that the object and the handler will be safe during the move. Do you have the proper personal protective equipment? Identify the space where you will move the object. Make sure there is room to house the object in its new location. If you have inadequate equipment, supplies, or space, postpone moving the object.

Plan your move.

Never consider moving an object routine work, even for daily housekeeping tasks. You must plan each step in the process before handling or moving a museum object. Where will you stand before picking up the object? Is there an open space to receive it? Planning helps keep handling to a minimum. When you plan, it helps you remember that each museum object is special. Keep in mind the following factors when you plan to move an object:

- ***Do you need to move the object?*** Is moving the object absolutely necessary? **If not, don't move it.**

- ***What are the object's structural characteristics and condition?*** Is it strong enough to withstand the move?
- ***Is there evidence of previous repairs?*** Review catalog records, condition reports, and photographs and examine the object to identify previous damage that may make the object especially fragile. Is there documentation that gives recommendations on moving hazards or safe moving techniques?
- ***What is the safest way to lift the item?*** How will you need to lift and carry the object to protect it from damage?
- ***How many people are required?*** Do you need help to move the object?
- ***Where is the object's new location?*** Is it large enough to properly house the object? Is the environment appropriate?
- ***What route will you use?*** Is it clear of obstructions?
- ***Will the personal health and safety of the handler be at risk?*** Do you have the proper moving equipment (for example, lumbar support belts or pallet jacks) to avoid physical strain? Do you need to wear a lab coat or dust mask?

5. *What are the basic rules for handling museum objects?*

When you handle objects use common sense and follow these basic rules to prevent damage to objects:

- Treat every museum object as if it were irreplaceable and the most valuable piece in the collection.
- Handle objects only when necessary.
- Move only one object at a time. Note: Small items can be moved together in a tote pan **if** they are separated and supported by padding.
- Never hurry.
- Take no risks.
- Never smoke, eat, or drink while handling objects.
- Avoid wearing anything that might damage objects by scratching or snagging the surface (for example, rings and other jewelry, watches, belt buckles, nametags, service badges).
- Use pencils, **not** pens, when working near objects.
- Keep hands clean, even when wearing gloves.
- Wear appropriate gloves.
 - Wear white cotton gloves when handling most objects.

- Wear plastic gloves (latex or nitrile gloves) when handling these types of objects:
 - slick objects like ceramics or glass
 - objects with oily or tacky surfaces that can attract cotton fibers
 - fragile or damaged paper or other organic materials that may catch on cotton fibers
 - some natural history specimens
- Know the condition of an object before moving it.
 - **Don't** lift by protruding handles or rims, which are often structurally weak.
 - Fragile objects should be given additional support, such as a tray or mount, before being lifted.
- Never layer or stack objects when moving them.
- Allow yourself plenty of space in which to work.
- Store objects so they can be easily moved without disturbing other objects.
- Tie on acid-free, cotton string tags or number trays, boxes, and bags so numbers can be easily seen without handling the object.
- Save all information associated with an object (for example, tags or labels).
- Remember to lift items properly.



Figure 6.4. Hold Objects at the Strongest Point. *A teapot should be handled by the base rather than by the handle or spout.*

The less museum objects are handled, the longer they will survive.

6. *What is the best way to protect an object I must pick up?*

When you pick up an object:

- Identify the strongest part of the object and hold it at this point.
- Take your time, handle only one object at a time, and use both hands.
- When an object has more than one part, for example, a teapot and lid, handle each part separately.
- Don't lift objects by protruding parts such as handles or rims.
- Stabilize any loose parts that cannot be removed.
- Move slowly and concentrate on what you're doing.
- Use a support board or tray whenever possible.

7. *When should I wear gloves?*

Gloves protect objects from contaminants such as dirt, salts, acids, and oils on your hands. Even clean hands can transfer these damaging substances. Wear clean, white cotton gloves except when handling ceramics, smooth glass, oily or tacky surfaces, fragile or damaged paper, or some natural history specimens. (Refer to Chapter 11 for a discussion of protective gloves to use when handling natural history specimens.) When handling these objects, wear tight-fitting latex or nitrile gloves for better gripping. Even when wearing cotton gloves, wash your hands frequently. Be careful not to rub your face and hair and then handle objects. Body oils may be transferred to the object and cause damage.



Figure 6.5. Wear Gloves and Use Both Hands.

Use two hands and wear gloves when handling museum objects.

Wear clean, white cotton gloves for handling many museum objects. Wear tight fitting latex or nitrile gloves when handling slick objects like ceramics or glass, objects with oily or tacky surfaces, fragile and damaged paper and other organic materials that can catch on cotton fibers, and some natural history specimens.

8. *What should I do if I damage an object?*

If you damage an object, report the damage. Damage should be recorded in the condition and condition description fields of the ANCS+ catalog record. Follow the instructions in the *ANCS+ User Manual* on reporting condition.

See *Museum Handbook*, Part II, Chapter 3, for information on how to do condition reporting.

Take photographs of the damage if possible. Save all pieces and carefully pack them so that no further damage occurs before a conservator can make repairs. Small pieces may be wrapped and bagged in self-sealing polyethylene bags labeled with the appropriate object identification information.

9. *What personal health and safety issues should I consider when handling museum objects?*

It is very important to follow health and safety precautions when handling museum objects.

- Practice safe lifting techniques. Remember to lift with your legs and not your back. Use proper personal support equipment, such as a lumbar support belt. Don't lift more than you can safely carry. See Figure 6.6 for a list of techniques that will help protect you from injury.
- Be careful how you handle potentially dangerous objects (for example, firearms, ammunition, and medicines). See *Conserve O Gram* 2/5, "Fossil Vertebrates as Radon Source: Health Update"; 2/8, "Hantavirus Disease Health and Safety Update"; and 2/10, "Hazardous Materials in Your Collection."
- Don't touch or inhale fumes or particles from objects treated with pesticides such as arsenic. See *Conserve O Gram* 2/2, "Ethylene Oxide Health and Safety Update"; 2/3, "Arsenic Health and Safety Update"; and 2/4, "Dichlorvos (Vapona) Update."

1. *Be sure you have firm footing and keep your legs apart.*
2. *Bend at the knees.*
3. *Use your leg and stomach muscles, not back muscles, when lifting from a stooped position.*
4. *Get close to the object and keep it near your body.*
5. *Avoid twisting; pivot using your feet.*
6. *Keep your back straight.*

Figure 6.6. How to Lift Properly and Avoid Injury.



Figure 6.7. The Proper Way to Lift a Chair.



Figure 6.8. The Proper Way to Lift a Small, Framed Photograph.



Figure 6.9. The Proper Way to Lift and Carry a Small Textile Object.

C. Moving Objects Within the Museum

Preventive conservation continues with the careful movement of objects. When you move objects you increase the risk of damage and loss because you are both handling them and changing their location.

1. *What should I do before moving objects within the museum?*

Before you move objects within the museum for dusting or cleaning, or any other purpose, be familiar with the rules you should follow that help reduce the risk of damage. Planning is essential before handling or moving any museum objects. Think through your plan so that you lift and move objects properly. With advanced planning, you can keep movement of objects to a minimum.

Moving puts an object at its greatest risk.

2. *What do I need to know before moving objects?*

Evaluate the object's condition and structure before moving it. Review object catalog records for condition reports, photographs, or other instructions that may provide information on the object's stability.

Know the object's condition and structure.

- Check the catalog card for any record of past damages.
- Check for loose parts or fragile surfaces. Careful examination will usually reveal if an object is not stable.
- Do I have to move the object? Constantly handling and moving objects can cause them harm.

Use safe handling practices.

Know the rules for handling museum objects. See Section B of this chapter. When lifting objects:

- Use both hands.
- Lift most objects from the base and/or close to the center of gravity.
- Don't try to push or drag objects across surfaces.
- Don't handle objects by handles or rims.
- Place objects inside containers (trays or boxes) for carrying (see Figure 6.9).
- Make sure objects are padded using museum materials (for example, polyethylene foam or acid-free tissue).
- Secure objects in separate compartments in a box or tray to prevent them from being damaged.
- Don't allow objects to stick out beyond the sides of the containers.



Figure 6.10. Use Trays and Padding to Prevent Damage.

These pipe bowls were placed in individual specimen trays within a larger tray to prevent damage during movement.

Use trained, experienced staff.

When selecting people to move objects:

- Evaluate the experience of the people handling and moving the objects.
- Assign specific tasks to each person.
- Review the move plan verbally with participants before moving the objects so that all understand their duties and assignments.

Use proper equipment.

Make sure you have the proper moving equipment so that the move is safe for both objects and people.

- Use the correct type of equipment. Useful equipment includes trays or baskets to support objects and flatbeds, carts, dollies, and pallet lifters to move objects.
- Inspect the equipment to make sure that it is safe for both the objects and the person handling the objects before you begin.
- Pad carts and other surfaces with polyethylene foam or another stable material to protect the objects.
- Postpone moving the objects if you don't have proper equipment, supplies, space, and trained helpers.
- Use rubber doorstops to prop doors open before you pass through.
- Use personal protective equipment when appropriate.

Clear the new location and the route there.

Before moving the object:

- Make sure the location is ready to safely house the object.
- Know which route to take, which equipment to use, and how much time you'll need to complete the move.
- Provide written instructions if needed.
- Be aware of all surfaces that the object may contact (for example, doors, floors, and walls).
- Study the spaces through which the object may pass (for example, doorways, stairwells, display areas).
- Avoid tight areas.
- Don't move objects during peak visitation periods or open hours, if possible.
- If transporting the object outdoors, move it when the weather conditions are good, with no rain, snow, or extreme heat. If this isn't possible, then take appropriate precautions such as waterproof coverings and packing to provide environmental buffering.
- Be aware of weather conditions at the final destination to determine the type of protective container needed.

D. Packing and Shipping Preparations

1. *When would I need to pack and ship objects?* Sometimes you must pack and ship objects to send them to a new location. For example, you may need to pack and ship objects for outgoing loans or conservation work.
2. *Why is it important to properly pack objects for shipping?* The hazards of shipping an object are numerous. Improper packing can cause an object to be permanently damaged or destroyed. A properly packed container is critical to ensure your objects arrive safely.
3. *How can I learn how to pack museum objects?* Begin by following the rules for the proper handling of objects. See Sections B and C of this chapter. The best way to learn how to pack is to work with an experienced packer. Learn to pack different types of materials, such as textiles and glass. **Each object requires a unique packing solution.** Museum professional associations often offer classes on packing and shipping.
4. *What kind of workspace do I need for packing?* You need enough room to work comfortably with the objects you are packing. For small objects you will need a table or desk; for larger objects you may need to have a portion of a room. For these larger objects, figure that you will need a space at least three times the size of the object you plan to pack. If you do a lot of packing, you should have a permanent packing area. When setting up a packing area:

- Select an area that can be cleared so you have sufficient room to safely pack the objects.
- Choose an area close to where the objects are stored to prevent unnecessary handling. Avoid continuously moving objects up and down stairways, around tight corners, or through narrow doorways.
- Pad the table with a few sheets of 1/8" polyethylene foam. Cover the polyethylene foam with 4-mil polyethylene sheeting. Securely fasten the sheeting beneath the work surface.
- When packing textile objects, pad surfaces with unbleached muslin over polyester batting.
- Remove all other tools and materials from the table while packing.

5. *How much time should I allow for packing objects?*

Packing can take several hours or even days, depending on the object. Allow yourself plenty of time to pack correctly. Don't hurry. Make sure each object is secure before moving onto the next.

6. *What do I need to consider before shipping?*

When you are preparing to ship an object, plan carefully. A lot of damage can occur during shipping. Movers may jar or drop objects. Airplane vibrations, exposure to bad weather, and rapid fluctuations in relative humidity can damage objects. Proper packing and shipping will limit these and other travel hazards including:

- shock and vibration
- sudden changes in temperature and humidity
- mishandling
- theft, vandalism, and loss

Before moving a museum object outside of the building, consider:

- the object's fragility
- the shipping method
- the climate through which the objects will travel
- the climate at the object's destination

7. *How do I determine if the object can be safely shipped?*

Carefully examine the object to see if its condition allows for safe travel. Be sure to check the condition and structure of items that can be very fragile. These include glassware, photos on glass, wooden musical instruments, paintings on wood, pastel paintings, charcoal drawings, and cracked porcelain. See the appendices in this volume for the particular problems you may find with different materials.

8. *How do I ship hazardous materials?*

To ship hazardous materials, such as nitrate film or firearms, you must follow special shipping requirements. The Bureau of Alcohol, Tobacco, and Firearms (ATF) has specific guidelines for shipping certain types of firearms. Contact the ATF's National Firearms Act Branch at (202) 927-8330 to determine the shipping requirements for your collection. Work with the company that will do the shipping to find out specific requirements for other types of hazardous materials. *Conserve O Gram* 14/8, "Caring for Cellulose Nitrate Film," gives information on shipping nitrate film.

9. *How should I document the condition of the objects?*

It is important to document the condition of an object before moving it. If an object is damaged, the documentation will help you determine the extent of the damage.

See *Museum Handbook*, Part II, Chapter 5: Outgoing Loans, for information about recording condition for loans. You may want to use the Object Condition Report (Form 10-637) to document an object's condition. For insurance and other purposes, when documenting condition:

- Use a portable light source and magnifying lens to help identify markings.
- Note and document areas that have been previously repaired.
- Carefully examine objects for pest infestation.

E. Packing and Shipping Materials

1. *Why is it important to use the right packing and shipping materials?*

Packing materials can adversely affect the object. Some materials are abrasive and can damage objects. Friable objects (for example, ancient glass, charcoal, pastel and conte crayon drawings, corroded metals) are susceptible to mechanical damage from even minor abrasion. Acidic tissue should not come in contact with objects that are acid sensitive. Some plastic bubbles and foams may leave imprints on polished metals, varnished woods, oriental lacquer and other smooth-surfaced objects. Materials that come in direct contact with the object must not stain, be abrasive or acidic, or off-gas damaging chemicals. To prevent these types of damage you should select appropriate materials for each packing situation. Never re-use packing materials on different types of objects as residues and dirt can be transferred.

This section describes materials commonly used in packing objects for transit. The bibliography lists a variety of references that can aid you in selecting proper materials and techniques. You can also contact your regional/Support Office (SO) curator or a conservator if you have questions about a specific material.

2. *What sources of packing materials are available?*

New packing products are continually appearing on the market. Contact museum packers to learn about new materials. If you choose a new material, be sure it has been tested and generally approved by the museum field. See *NPS Tools of the Trade* for some suggestions. You can obtain other supplies from the following sources:

- General Services Administration Federal Supply Schedule (look under "Cushioning Materials" or "Packaging and Packing Supplies")
- *Storage of Natural History Collections: Ideas and Practical Solutions*, put out by the Society for Preservation of Natural History Collections (listed in the bibliography)
- local telephone directories (look under "Boxes," "Packaging Containers," and "Packaging Materials")
- businesses specializing in packaging for high-tech electronic equipment

Ask your regional/SO curator if you are unsure about any materials you want to use.

3. *What are good covering and wrapping materials?*

Good covering and wrapping materials include:

- ***Acid-free glassine paper*** is stiff, translucent, and glossy in texture. You should use glassine only for short-term storage (less than 30 days). Glassine is recommended for covering paintings, bottles with labels, or objects with a friable or oily/tacky surface. Use only new glassine paper since it deteriorates and becomes acidic over time.
- ***Tyvek*** is an alternative to glassine. This material is available in soft textile-like or slick, smooth finishes. Tyvek is a type of high-density polyethylene and is stable for long-term use.
- ***Tightly woven nylon fabric*** can be used to cover cushioning foams to protect the object. Make sure nylon doesn't come into contact with the surface of delicate materials as it can be abrasive.
- ***Cotton knit*** (available in rolls) is another good covering material. It is a good, soft cover for polyethylene foam supports.
- ***Unbleached washed muslin*** can be used for wrapping sculpture and textiles. Wash muslin in hot water several times before using it to remove sizing and make it softer.
- ***Soft, unbuffered acid-free tissue paper*** is used for covering basketry, metal, and textiles. It is also good for making pads to fill empty spaces and covering appendages on objects.
- ***Mylar®*** is a clear, stable polyester film that serves as a good primary protector for paper. Mylar has an electrostatic charge. **Never use it on pastels or charcoal drawings.**
- ***Blanket pads or quilts*** are used for covering large sculpture and furniture.
- ***Acid-free folders*** are used to contain unframed prints, documents, and photographs.

Examples of when and where to use these materials can be found in the references listed in the bibliography.

4. *What are good cushioning materials?*

Cushioning materials are designed to absorb shock and buffer the humidity. These materials are usually foam products that you can use in a variety of cushioning techniques. Use each type of foam correctly to achieve adequate shock and vibration protection. Because each foam product offers different cushioning qualities, you may want to use a combination of foams. The Canadian Conservation Institute (CCI) has designed tools (The Circular Slide Rule for Cushion Design and PadCAD computer program) to help museums estimate how much cushioning material to use. These aids help you evaluate the shock that occurs when a package is dropped from a certain height. This calculation helps you determine how much and what kind of cushioning materials you should use. You can obtain these aids directly from CCI, 1030 Innes Road, Ottawa, ON KIA OM5, Canada (613) 998-3721 <<http://www.pch.gc.ca/cci-icc/>>.

A few good cushioning materials are listed here:

- **Bubble-pack™** is a plastic sheet with trapped air bubbles. Bubbles can leave impressions on an object's surface so use this product with the bubble side facing away from the object's surface. Don't use it with sharp objects that can break the bubbles. Use several layers to maximize the padding effect. Always wrap the object first with tissue or muslin to protect the surface and to buffer relative humidity.
- **Polyethylene foam sheets (Ethafom, Volara)** are light, easily handled, shock absorbing, chemically inert, and a barrier to moisture. Join sections with a heat gun, glue gun, or double-faced tape. These sheets are available in various densities, thicknesses, and textures. Use only white sheets; blue and pink sheets contain additives that may cause deterioration.
- **Polyurethane foam** is one of the best cushioning agents and it cuts easily. Its soft springy nature absorbs shock very effectively. It is very unstable, however, so use it only for **short-term** transport packing. Always put a barrier, such as acid-free tissue or Tyvek, between this foam and the object.

One packing material commonly used is **plastic "peanuts,"** which are expanded polystyrene. These are usually not appropriate for museum objects. They are messy, retain moisture, and they cling to surfaces. They are also difficult to remove if they get caught in appendages. If you must use these peanuts, do so only with small, light objects (<5 lbs.) or as a pad of peanuts collected in polyethylene bags. **Plastic "potato chips"** are a better form for providing padding.

5. *What materials make good interior boxes?*

Double boxing gives extra protection to objects (see Section F.5). The interior boxes can be made from a variety of materials. Many objects can be packed inside double-strength fiberboard boxes. You can also use polyethylene or polystyrene boxes. These plastic boxes will also protect objects from water damage.

Sometimes you may need to make a specially shaped box to pack odd-sized objects. There are several materials you can use to produce specialized interior boxes:

- **Foam-Cor®** is a polystyrene foam sandwiched between two layers of clay-worked kraft linerboard.
 - **Archival corrugated board** is an acid-free, lignin-free cardboard.
 - **Vapor barrier films** are a variety of laminate metal and plastic sheet materials that allow very little penetration of oxygen or water vapor. They make good box liners and can help maintain the interior microclimate.
 - **Cellophane and masking tape** can both be used to attach packing materials. Don't use these for closing the outside of the container, as they are not strong enough to resist damage during shipping.
 - **Pressure-sensitive plastic tape** can be used to seal the outside of the container.
 - **Water activated paper tape** can be used for sealing containers and attaching kraft paper. The 3"-width tape is best.
 - **Nylon reinforced strapping tape** should only be used for closing containers. The adhesive on this tape is very sticky and strong, so be very careful to keep it away from objects or wrapping materials that may contact objects.
6. *What kind of tape should I use on the box and the wrapping material?*

Don't allow any tape to contact the surface of objects.

7. *How should I select an exterior container?*

A quality exterior container contributes to an object's safe travel. Select containers prior to packing. Consider the following criteria:

- the physical characteristics of the item you are shipping (for example, size, weight, fragility)
- how much space the object needs inside the container for the object to fit comfortably and securely
- the method of transportation and who will handle the container
- environmental and weather changes that may require humidity and temperature buffering
- the number of times the object will be packed and unpacked

Exterior containers are fabricated from metal, wood, cardboard, fiberglass, and high-density plastics. The best exterior containers are:

- puncture proof
- light proof

- watertight
- protective against shock or vibration
- good environmental buffers

8. *What kinds of containers do I use for objects that have different weights and sizes?* You should pack objects according to their weight, height, and density. Pack light objects in double strength cardboard boxes. Heavier objects (for example, paintings, sculpture, and furniture) or valuable and fragile items need the extra support of wood, fiberglass, or high-density plastic. You may have to build a special container customized for the object or hire a professional carpenter to build one.
9. *Can I build an exterior container?* Build a container only if you have good carpentry skills and packing experience. You can use nails and glue to build the container, but use screws on the lid once the object is in the box. Never use nails on the lid because they can accidentally pierce the object. Vibrations from hammering or prying open the lid may also cause damage to the object.
- Line the interior of the container with polyethylene sheeting, Tyvek, or vapor barrier film to protect the objects from water and to help buffer the interior microclimate. Add gaskets, skids, handles, and battens as needed for protection. Use castors on large containers to facilitate movement.
- For more information on the specifics of making a box for shipping museum objects, see the references at the end of this chapter.
10. *Can I use a reusable shipping container?* If you frequently pack and ship objects you might want to purchase reusable polyethylene containers. The Museum Management Program can provide more information on reusable containers and where you can get them.
11. *How do I protect objects from environmental changes during shipping?* Containers will be exposed to temperature and relative humidity changes during the shipping process. These environmental changes can affect the object inside. Hygroscopic materials (materials that readily absorb moisture) used as packing materials can act as a buffer against relative humidity changes within the container. Wood, paper, natural fiber fabrics, and silica gel are good examples of hygroscopic materials that make good packing materials.
12. *How should I store packing materials?* Keep packing materials in a clean, dust free, controlled environment. Avoid accumulating excess packing materials if you don't have adequate storage space for them because they increase both the risk of fire and the chance of infestation. If possible, store them in an environment with stable humidity between 40-60% RH. Wood crates and packing materials absorb moisture and pollutants. If the crates absorb more moisture than is recommended, allow them to adapt to the same environment as the object for two weeks prior to shipping. Open the lid to speed the process. Before bringing packing materials into the collections area, check all materials for pest infestation.

F. Packing for Shipping

Once you have selected your packing materials and decided on the kind of interior and exterior container you will use, you need to pack your object. This section discusses how to pack and cushion an object so it will not be damaged from shock and vibration. It also describes the documentation that you should include inside the container.

1. *How do I decide which way to position an object in a container?*

Evaluate the object's shape and size before packing. Plan for the worst possible travel scenario. Consider the object's weight and center of gravity. When you position the object:

- Place the heaviest part of the object low and close to the center of the container.
- Place glass-covered framed works of art vertically with padding between each item.
- Separate parts of objects (for example, a teapot and lid) and wrap separately.
- Immobilize and dismember objects with moving parts (for example, a spinning wheel) and wrap parts separately.
- Provide additional support for heavy parts of an object.
- Pack only objects of similar weight in the same container.



Figure 6.11. Pad and Separate Parts.

Pad moveable parts and separate parts of an object to avoid damage during handling.

2. *How do I cover and wrap an object?*

Use an initial covering to protect objects from abrasive packing materials and to serve as an additional buffer. Use soft, unbuffered, acid-free tissue for most objects. If possible, don't use tape to hold the covering material closed. Instead, tuck the tissue in on itself or into an appendage. This removes the chance that tape will get stuck to the object. Don't wedge

tissue so tightly that it exerts stress on the object. **Never crumple tissue in wads.** Insert smooth pillows of tissue between parts of an object.

Wrap paintings in glassine paper or Tyvek. Don't use plastic as it can trap moisture if the temperature drops radically during shipping and condensation occurs. This moisture can support mold growth and many other types of deterioration.

After you cover the object, round off all projecting parts and handles with tissue. For example, imagine you are wrapping a teapot. Place soft, unbuffered, acid-free tissue around the spout, inside the teapot, and in the open space under the handle. The end result is a rounded-off ball of tissue where projecting parts are protected by the whole. Wrap the entire teapot in one sheet of tissue or bubble-wrap to hold padding in place. Label the exterior wrapping with object identification information (for example, object name and catalog number).

3. *How should I cushion the object inside the container?*

There are several ways to properly cushion objects inside the packing container:

- Use packing materials (for example, bubble-wrap, polyurethane, or polyethylene foam blocks) that help absorb shock and vibration and create a thermal barrier.
- Always provide at least two inches of cushioning between objects in the same container.
- Provide at least two inches of cushioning between objects and the walls of the container.
- Allow three to four inches between very fragile items like ceramics and glass and between heavy objects.
- When determining the number of objects you may pack in one container, use common sense. Consider weight, fragility, and sensitivity to environmental conditions. For example, do not pack heavy metal industrial parts with china. Likewise, environmentally sensitive ethnographic objects require more buffering material than historic metals.



Figure 6.12. Wrapping, Padding, and Packing for Shipping an Object.

4. *What other techniques can I use to cushion objects and provide shock absorption?*

There are a variety of techniques that you can use to cushion objects. These techniques include:

- double boxing
- cavity packing
- padding negative spaces
- cushioning braces

You should base your selection on the fragility, size, and construction of the object as well as the modes of transportation during shipping.

Double Boxing

Double boxing is the process of packing an object in two sequential boxes. It's an excellent way to cushion objects. Follow these steps:

- Wrap the objects and cushion them inside one box.
- Pack the first box inside a second box at least two inches larger on all sides.
- Completely fill the spaces between the boxes with newspaper or foam, or use corner blocks or plastic rings between the boxes.



Figure 6.13. Objects Double-boxed for Shipping.

The straps make it simple to remove the interior box.

Cavity Packing

Cavity packing is the process of placing small to medium-sized objects in hollows cut into layers of polyethylene foam. This technique is clean and easy to use in repacking. To cavity pack:

- Trace the shape of the objects.
- Mark the shape on the foam with a pencil.
- Cut out the contour with a bread knife or electric carving knife.
- Protect the object against abrasive polyethylene material by covering the cavity with soft, unbuffered acid-free tissue, Tyvek, or another smooth inert material.

Padding Negative Space

Use this technique for less fragile objects. Surround the object with tissue paper and then wrap it with successive layers of bubble wrap. Place the object inside the container and use pads of tissue, bags of packing peanuts, or soft foam to fill in the excess area. Allow several inches between each object and between the objects and the inner container. Larger, heavier objects will need more separation than small, lightweight objects. When using this technique for open objects (for example, pots or baskets) fill them with tissue to prevent collapse caused by the pressure of surrounding objects.

Cushioning Braces

A cushioning brace holds the object in place and may be necessary to immobilize the object when padding negative spaces. To make a cushioning brace, measure the distance between the object and the container. Build polyethylene blocks to fill in the space. Cover the polyethylene with a less abrasive material such as soft acid-free tissue to protect the object. Place packing material on top of the object to prevent it from moving during shipping, but don't overfill the box. Overfilling places too much compression on the object.

5. *What should I do before closing the container?*

Before you close the container, place packing material above the object to prevent movement if the box is overturned. Avoid too much compression so that padding material does not damage the fragile objects. Cushioning material should support and enclose but not compress the object. After you finish packing, lightly jar the container to determine if objects can shift. If they can, you must repack the container.

You should create an inventory of all contents inside the lid of each packing container. If the procedures for unpacking are complicated, include written unpacking instructions or a sequence of photographs showing the proper packing or unpacking procedure. Unpacking in an incorrect order can cause damage. Place a label with the address neatly typed or printed inside the box in case the exterior address is lost or destroyed.

6. *Should I wrap and label the shipping container?*

After a box is packed you may want to wrap it in paper to give it a finished, clean appearance. If you must wrap a box, do it carefully and neatly. A poorly constructed and shoddily wrapped container invites people to mishandle it. A neatly wrapped and properly labeled container encourages handlers to be careful. Kraft paper is an excellent exterior wrap for containers. Tape all open edges and folds of the paper.

7. *What should I put on the label on the exterior of the container?*

Prepare the exterior label as follows:

- Always print the name and address of the recipient in permanent ink.
- Write the recipient's name and address directly on the outside of the box as well as on any wrapper. This way, if the wrapper is torn, the package will not have to be opened to get the name and address of the recipient.
- Place the typed or neatly printed address in the center of the box. Place a duplicate label with this information inside the box. If the address is a P.O. Box, include the telephone number on the label.
- Always include the name of the recipient on the address label. Phone before you ship so that the recipient will be expecting the shipment.

8. *What kind of identification markings should I put on the box?*

- Write neatly on the top, "OPEN THIS SIDE."
- Put arrows on the sides to let the handlers know which end is up.
- Add necessary labels to warn handlers and give them information they may need to know to properly handle the box. For example:
 - Label the package "FRAGILE" if the contents are delicate.
 - Add the proper hazard label for nitrate film and other hazardous materials.
 - Print specific instructions such as, KEEP DRY, DO NOT TILT, HANDLE WITH CARE.
- Mark the total number of boxes on the address labels (Box 1 of 2, Box 2 of 2).
- Make sure all labels are secured with strong tape or adhesive.
- **Don't** attract thieves by writing "Works of art" or "Museum objects."

G. Shipping Objects

1. *What things should I consider if I use a professional packer/shipper?*

You may decide to contract for packing/shipping service. However, be aware that professional packers/shippers seldom have knowledge of and sensitivity to the delicacy of museum objects. Use shippers who've handled museum collections before or who specialize in museum collections. The reputation of a particular art packer or carrier is an important factor to consider. Get referrals from your regional/SO curator and other parks or local museums. Check references of any firm you plan to hire. After you select a company, discuss and confirm the following points of information about the shipment:

- size and weight limitations
- insurance coverage
- costs and payment terms
- pick up and delivery times

The park should also be specific with the carrier about meeting NPS standards. Finally, be prepared to supervise and give specific instructions for packing/shipping the objects.

Park curatorial staff should inform the regional/SO curator of positive and negative experiences with particular art packers and carriers. This information will help to maintain a current list of available packers and carriers for referral to other parks.

2. *What transportation alternatives are available for shipping museum objects?*

There are several options for transporting museum objects. These include:

- U.S. Postal Service
- package delivery services (for example, United Parcel Service (UPS) or Federal Express)
- motor freight
- airfreight
- courier

Your selection depends on:

- size
- weight
- distance
- object fragility
- extra services required

Specific features and limitations of each alternative are described below.

3. *When should I use the U.S. Postal Service?*

Use the U.S. Postal Service (USPS) for objects that are not fragile or of special significance (for example, high monetary, associational, or research value). Always mail "priority" class to reduce transit time. Send by registered mail, return receipt—the most secure service offered by the USPS. With registered mail the USPS monitors the movement of your package from the point of acceptance at the post office to delivery. You will receive a receipt when you mail your package and a delivery record is kept at the post office at the other end. When you request a return receipt, you will receive a receipt showing who signed for the item and the date that it was delivered. Completed packages must weigh less than 70 pounds and measure less than 108 inches in combined length and circumference.

4. *When should I use commercial package delivery services?*

Use commercial package delivery services such as United Parcel Service (UPS), Federal Express, or Airborne Express for shipping sturdy objects. These companies have limits on the value of objects they will ship and insure. Talk to the company you choose to find out:

- value limits (companies often will not ship objects worth more than \$50,000) For more information on appraisals, see *Museum Handbook*, Part II, Chapter 4: Inventory and Other Special Instructions.
- insurance requirements (most companies have a basic insurance coverage, but require you to purchase higher limits)
- size and weight limits

- pick up and delivery alternatives (for example next day, second day, weekend)

Be sure to require the service to sign and return an Acknowledgment of Delivery form. When shipping to a large institution, specify that a specific person or department must sign for the delivery. This is to ensure that the package is not left at a loading dock or reception desk.

5. *When should I use an art shuttle van or special product truck?*

Art shuttle vans and special product trucks offer another form of transportation for museum objects. Some national van lines and specialized art handling companies offer these services. However, they are subject to side routing, delay, and transfer between vehicles. When choosing this shipping method, discuss in detail the route and process that the transport will use. Ship only in air-ride suspension trucks that can absorb road shock. Transport objects sensitive to temperature and relative humidity changes in a climate controlled van. Cost is based on size of shipment, weight, distance, and extra services such as pick-up, non-stop delivery, climate control, and daily progress reports. You can find other information about specialized shippers in the AAM Products and Services Directory under “Shipping and Moving Companies.”

6. *When should I use airfreight?*

Airfreight is a fast transportation method, but it can be expensive. Airfreight also subjects objects to considerable handling. However, with airfreight, the object is out of your control for the least amount of time.

A typical airfreight-shipping scenario looks like this:

- 1) Truck or van transports the object to the airport.
- 2) Objects sit on the loading dock.
- 3) A forklift carries objects to the plane.
- 4) The objects fly on one or more planes.
- 5) A forklift unloads the objects. They may sit for a time on the loading dock:
- 6) A van takes the objects to the final destination (airfreight companies generally contract for pickup and delivery services).

Plan routing carefully to minimize stopovers and plane changes. This prevents unnecessary loading and unloading or an unattended crate at the loading dock. Be mindful of pressure differences between ground and flight level that may affect pressure-sensitive objects. Size limitations are related to airplane configuration. Weight and dimension of the shipment normally determine air shipment charges. Seek out an airfreight forwarder to help you coordinate air and ground transport.

7. *Should I use a courier?*

All of the above techniques have some level of risk. You can reduce this risk by using a courier. Using a courier decreases the possibility of loss. Because of the fragility, sensitivity, and high value of most museum objects, consider having a courier accompany the object during transit. A courier is also recommended if the trip is complex with many carrier changes. Someone with knowledge of conservation, museum documentation, and object handling techniques may serve as a courier. This person might be either a hired agent or a NPS employee.

As a courier on an airplane, you must:

- Make all arrangements in advance with the airline. Explain what you will be carrying, loading, and unloading.
- Check on airline size limitations before planning for a hand-carried shipment.
- Purchase an extra seat for the object if necessary.
- Secure the object (container) with a seat belt unless it will fit under your seat or overhead compartment.
- Never let the object out of your sight.
- Do not carry hand luggage that gets in the way of the object.
- Do not reveal the contents of the package to other passengers.
- Try to board before and disembark after other passengers.
- Supervise the loading and unloading of objects in the cargo hold and accompany the object from the plane to the cargo shed.
- Deliver the museum object as soon as possible.

If traveling by car:

- Be sure someone is always with the object in the vehicle.
- Stop only when necessary.

H. Receiving and Unpacking the Container

1. *How should I unpack a container?*

You should use as much care unpacking a box as you use in packing it. Follow these basic instructions:

- When you receive a shipment, don't open the box for 24 to 48 hours to allow the contents to acclimate to the new environment.
- If the box exterior is damaged, note the problem on any receipt of acceptance that you sign. This identifies the fact that damage occurred before the box arrived at the park.
- Cut tape carefully to avoid excess pressure on and damage to the object.
- Check for unpacking instructions that may be included with the box.
- Check the contents of the box against the packing list to ensure that everything is present.

- Flatten all packing materials completely to be sure that no object pieces or small items are still inside.
- If the object has to be repacked to return it, place the packing materials inside the box or crate and save the container.
- Take careful notes on the unpacking sequence and label all packing boxes and supports so they can be reused properly.
- Never permanently store museum objects in packing containers. Such containers are for short-term transportation needs.

2. *Should I check for insect infestation?*

As soon as you unpack the box you should check for pests:

- Thoroughly check the object for signs of infestation such as shed larval skins or live insects.
- If infestation is noticed, immediately isolate the object and develop a strategy for dealing with the infestation. If the item does not belong to you, contact the owner and solicit their input when developing your strategy. See Chapter 5: Biological Infestations, in this handbook, or contact your regional/SO curator for additional information.

3. *What do I do if an object is damaged, lost, or destroyed during shipping?*

All shipments should be insured with wall-to-wall insurance coverage. See *MH-II*, Chapter 4, for information about insuring shipments. If an object is damaged when it is returned, document the damage. Damage should be recorded in the condition and condition description fields of the ANCS+ catalog record. Follow the instructions in the *ANCS+ User Manual* on reporting condition. See *MH-II*, Chapter 3: Cataloging, for information on how to do condition reporting.

Take photographs of the damage if possible. Save all pieces and carefully pack them so that no further damage occurs before a conservator can make repairs. Small pieces may be wrapped and bagged in self-sealing polyethylene bags labeled with the appropriate object identification information.

If the damage occurred during shipping, report the damage to the shipping company and submit an insurance claim. You will have to provide evidence that the object was not damaged before shipment.

If an object is lost or destroyed during shipping, report the loss and deaccession the object. Follow the procedures outlined in the *MH-II*, Chapter 4: Inventory and other Special Instructions, Section III, "Reporting Loss of Museum Objects," and Chapter 6: Deaccessioning, Section H, "Loss, Theft, Involuntary Destruction, Abandonment or Destruction."

I. Selected Bibliography

- Alberta Museums Association. *Basic Principles of Artifact Care and Handling*. Edmonton, Alberta, Canada: Alberta Museums Association, 1991.
- American Association of Museum. *The Official Museum Directory, Volume 2, Products and Services*. New Providence, N.J.: National Register Publishing, 1998.
- Dudley, Dorothy. "Chapter 7: Packing and Shipping." In *Museum Registration Methods*: Washington, D.C.: American Association of Museums, 1979.
- Fall, Frieda Kay. "General Rules for Handling Art Museum Objects," *Museum News*. 43, no. 1 (1964): 33-39.
- _____. *Art Objects: Their Care and Preservation, a Handbook for Museums and Collectors*. La Jolla, Calif.: Laurence McGilvery, 1973.
- Gallery Association of New York State. *Way to Go: Crating Artwork for Travel*, Hamilton, N.Y.: Gallery Association of New York State, 1985.
- Gilmore, Jean Allman, and Rebecca A. Buck, eds. *The New Museum Registration Methods*. Washington, D.C.: American Association of Museums, 1998.
- Hansen, Greta, and Dennis V. Piechota. "The Care of Cultural Property in Transit: A Case Design for Traveling Exhibitions." *Technology and Conservation* (Winter 1982).
- Keck, Caroline K. *Safeguarding Your Collection in Travel*, Nashville, Tenn.: American Association for State and Local History, 1970.
- Lister, Joyce. "Safeguarding Museum Collections: A Review of Handling," *Museum Quarterly* (Summer 1984): 23-26.
- Mecklenberg, Marion F. *Art in Transit: Studies in the Transport of Paintings*. Washington, D.C.: The National Gallery, 1991.
- Odegaard, Nancy. *A Guide to Handling Anthropological Museum Collections*. Tucson, Ariz.: Western Association for Art Conservation, 1992.
- Powell, Brent. *Technical Drawing Handbook of Packing and Crating Methods*. Packing and Crating Information Network. Washington, D.C.: American Association of Museums, PACIN Task Force, 1993.
- _____, comp. *Soft Packing: Methods and Methodology for the Packing and Transport of Art and Artifacts*. Washington, D.C.: American Association of Museum, PACIN Task Force, 1994.
- Richard, Mervin J. "Elements for Effective Packing," *Museologist*, 45, no. 166 (Winter 1983-4).
- Richard, Mervin J., Marion F. Mecklenberg, and Ross M. Merrill, eds. *Art in Transit: Handbook for Packing and Transporting Paintings*. Washington, D.C.: National Gallery of Art, 1991.
- Rose, Carolyn, and Amparo R. de Torres, eds. *Storage of Natural History Collections: Ideas and Practical Solutions*. Pittsburgh, Pa.: Society for the Preservation of Natural History Collections, 1992.
- Rose, Cordelia. *Courierspeak: A Phrase Book for Couriers of Museum Objects*. Blue Ridge Summit, Pa.: Smithsonian Institution Press, 1993.

Rowlison, Eric B. "Rules for Handling Works of Art," *Museum News* 53, no. 7 (1975): 10-13.

Sandwith, Hermione, and Sheila Stainton, *The National Trust Manual of Housekeeping*. London: Allen Lane, 1984.

Shelley, Marjorie. *The Care and Handling of Art Objects*, rev. ed., New York: The Metropolitan Museum of Art, 1986.

Sixsmith, Mike. *Touring Exhibitions: The Touring Exhibition Group's Manual of Good Practice*. London: Butterworth-Heinemann, 1995.

Stowlow, Nathan. "Conservation and Exhibitions-Packing, Transport, Storage and Environmental Considerations," *Museum and Monuments XVII*, UNESCO, Boston: Butterworths, 1987.

Taylor, Loretta, ed. *Basic Principles of Artifact Care and Handling*. Alberta, Canada: Alberta Museums Association, 1991.

Rules for Handling Objects in Park Collections

1. AVOID wearing anything that might damage objects by scratching or snagging the surface, such as rings and other jewelry, watches, belt buckles, nametags, and service badges.
2. NEVER smoke, eat, or drink around the objects.
3. Handle objects only when necessary.
4. LOOK carefully at an object before lifting. Ask yourself:
 - Is the surface fragile?
 - Are there any clues to make me think it is damaged?
 - Where am I going to put the object, and is there a clear space set aside for it?
5. Use BOTH HANDS to lift an object.
6. If an object is in a container, lift only the container.
7. WEAR GLOVES when lifting objects
8. Wash your hands before putting on cotton gloves. Oils and acids can soak through gloves.
9. If you break something, tell the Curator.

Figure 6.14. Example of Written Handling Rules for NPS Park Collections

Chapter 7: Museum Collection Storage

	Page
A. Overview	7:1
What is museum collection storage?.....	7:1
How does collection storage fit into my park's preventive conservation program?	7:1
What is a collection storage system?	7:1
B. Standards and Requirements for Collection Storage	7:2
What are the museum collection storage standards and requirements?	7:2
Where do I start in establishing my collection storage needs?.....	7:3
What are the collection storage facility and space requirements?.....	7:3
How do I ensure that I have adequate space to store the collection?	7:3
What general building features contribute to storing the collection?.....	7:3
What design loads should my storage space or facility have?	7:5
Where do I find additional information on storage space requirements?	7:6
Why should my collection storage space be used exclusively for storing collections?.....	7:6
Where should I locate the research space?	7:6
Where should I locate work and office spaces?.....	7:6
How do I establish proper physical security for the collection storage space?.....	7:6
How important is fire protection in the storage space?	7:6
What should the collection storage environment be?	7:7
What are museum storage equipment and container requirements?	7:7
Does housekeeping have a role in collection storage?	7:7
C. Planning Collection Storage Space	7:8
How should I plan my museum storage space?	7:8
What is a Collection Storage Plan (CSP)?	7:8
What does the collection storage chapter or section of a CMP, CCS, or archival assessment contain?	7:9
Who can write a collection storage planning document?	7:9
How much does a storage planning document cost?	7:9
Where do I get funding to do a collection storage planning document?	7:9
D. Assessing Collection Storage Needs	7:10
How do I assess the collection?.....	7:10
How do I assess physical security needs?	7:10
How do I assess fire protection needs?	7:11
How do I assess environmental monitoring and control needs?	7:11
How do I assess museum storage equipment needs?	7:13
How do I assess object storage techniques and methods?	7:14
Where do I include technical supporting information and drawings such as floor plans in the storage planning document?	7:14
E. Assessing the Current Collection Storage Facility or Space	7:14
How do I assess the existing storage facility or space?.....	7:14
How do I represent and record information about the storage space and structure?.....	7:15
F. Planning a New or Upgraded Storage Space	7:16
How do I determine the storage equipment needed?	7:16
How do I determine how much space is needed to store my collection?.....	7:16
What process do I use to evaluate potential storage locations?.....	7:16
What storage space alternatives should be examined?.....	7:16

What occurs in the evaluation, development, and recommendation phases of a value analysis?...	7:18
What other storage factors should I consider?	7:18
G. Housing Museum Objects	7:19
Why is it important to use specialized museum storage equipment?	7:19
What types of equipment does the NPS use for storing museum collections?	7:19
What are some general considerations when using museum equipment?.....	7:20
H. Using Containers and Supports	7:21
Why is it important to use storage containers and supports?.....	7:21
What kinds of containers and supports should I use for storing museum collections?.....	7:21
Where do I find information on techniques for storing different types of museum objects?.....	7:22
I. Storage of Museum Collections Subject to the Native American Graves Protection and Repatriation Act of 1990 (NAGPRA)	7:22
What is NAGPRA?	7:22
What types of items subject to NAGPRA are found in NPS museum collections?.....	7:23
Are there any special storage requirements for items subject to NAGPRA?	7:23
How should I store collections subject to NAGPRA?.....	7:23
Whom should I contact for assistance?.....	7:24
J. Bibliography	7:25
K. List of Figures	7:28

CHAPTER 7: MUSEUM COLLECTION STORAGE

A. Overview

1. *What is museum collection storage?*

Museum collection storage is both a space and a process.

- It is space that you dedicate to storing museum objects, natural history specimens and archival items. It is space that is either designed or upgraded for the maximum protection and optimum use of the collection.
- It is the process of properly containing and caring for the museum collection while it is in the collection storage space. Each decision you make about storage should consider how changes would improve the protection and preservation of the museum collection.

2. *How does collection storage fit into my park's preventive conservation program?*

Good collection storage is a major component of a preventive conservation program to preserve your museum collection. A well-planned and organized storage space reduces the risk to the object. Deterioration, damage, or loss will be minimized if you have:

- proper storage techniques
- good handling practices (see Chapter 6)
- effective security and fire protection (see Chapter 9)
- appropriate environmental conditions (see Chapter 4)
- a pest free environment (see Chapter 5)

A well-planned and organized storage space also ensures that the objects are accessible. When you place an object on exhibit you usually compromise the conditions that are best for preservation. However, collection storage is a different matter. You can achieve ideal preservation conditions for objects that you keep in storage.

3. *What is a collection storage system?*

Preserving museum objects in storage involves evaluating the total museum storage system housing the collection. A collection storage system is the protective envelope surrounding the collection. It includes three levels of containment:

- the facility or space
- the equipment
- the containers

Although museum collection storage varies from park to park, the factors that need to be considered to properly house a collection remain the same. Evaluate each level of the system and adapt it to meet your park's specific collection preservation and protection needs. Be practical and evaluate the space available to house the collections as well as the cost, both in funds and staff time available.

The levels of containment in a collection storage system are illustrated in Figure 7.1. Each level adds additional protection to your collection by shielding it from the agents of deterioration.

B. Standards and Requirements for Collection Storage

1. *What are the museum collection storage standards and requirements?*

Museum collections require special storage conditions. Standards and requirements for managing museum property are based on Departmental and NPS policy and professional museum practices.

The Interior Departmental Manual, Part 411, Policies and Standards for Managing Museum Collections, Chapter 3, provides departmental standards for museum property storage.

The NPS *Management Policies* (p.5:13) states:

“The National Park Service will employ the most effective concepts, techniques, and equipment to protect cultural resources against theft, fire, vandalism, environmental impacts, and other threats without compromising their integrity or unduly limiting their appreciation by the public.”

The “NPS Checklist for Preservation and Protection of Museum Collections” provides general standards for collection preservation and protection. See Appendix F: NPS Museum Collections Management Checklists.

NPS collection storage standards can be summarized as follows:

Safe and secure storage of museum collections requires dedicated space. You must use museum storage areas only for museum collections. To the extent possible, separate museum storage from all other uses, including office space and research and work areas. Museum collections require suitable and sufficient space. The space you select for museum storage must be adequate to accommodate the particular characteristics and quantity of objects, specimens, and archival items you have in your collection and provide adequate space to accommodate reasonable growth of the collection. Organize the space to allow for the efficient use of curatorial equipment and techniques and to provide for effective access and optimum preservation of the museum collection. House objects in appropriate containers and package objects with appropriate materials.

2. *Where do I start in establishing my collection storage needs?*

Complete the “NPS Checklist for Preservation and Protection of Museum Collections.” (See Appendix F: NPS Museum Collections Management Checklists.) This checklist helps you evaluate your collection storage needs in the following areas:

- facility and space requirements
- protection requirements (physical security and fire protection)
- environmental requirements
- museum equipment and container requirements
- housekeeping requirements

You complete the checklist using the Automated Checklist Program found in the Utilities Module of ANCS+. See Appendix G in the *ANCS+ User Manual* for more information.

3. *What are the collection storage facility and space requirements?*

Facility and space requirements deal with space adequacy, construction features, and design loads for collection storage.

Make sure the collection has suitable and sufficient space for proper storage. Suitable space is planned space that has been evaluated for its adequacy for storing museum objects. Outbuildings, closets, and unimproved basements and attics are not suitable space. These inadequate spaces rarely contribute to the preservation and effective use of a collection.

The following guidance elaborates or expands on the standards in Appendix F.

4. *How do I ensure that I have adequate space to store the collection?*

The storage space must be large enough to accommodate the existing collection as well as the projected growth of the collection over the next 10 years. Your space should:

- allow use of proper storage equipment and techniques
- incorporate aisles at least 48" wide between rows of equipment; this width allows safe handling and movement of drawers, cabinet doors, and larger objects

Make sure the space allows movement of personnel, equipment and objects in and out without hindrances such as inadequately sized doors; narrow, winding, or steep stairs; or passageways with low ceilings.

Carefully plan and organize your storage space to make the collection easy to access for study, exhibition, or accountability.

5. *What general building features contribute to storing the collection?*

Collection storage facilities and spaces should be constructed to meet the following requirements:

- Make sure the storage space is not located on a 100-year floodplain. This is in accordance with Executive Order 11988, "Floodplain Management," May 24, 1977 (42 USC 4321), and Natural Resources Management Guideline (NPS-77).
- Use space that is constructed of fire-resistant or fireproof materials. Wood framed walls and ceilings should be constructed with gypsum wallboard to achieve a minimum one-hour fire rating (some codes may require a two-hour fire rating).
- Use space with as few windows and doors as practical to enhance security and environmental control, but not so few as to be in violation of health, safety and fire codes. See National Fire Protection Association *NFPA 101*, "Life Safety Codes," 1997 Edition, and *OSHA Standard 1910.36*, "General Requirements, Means of Egress."
- Use space with as few exterior walls as practical. This will minimize the chance of condensation on walls and windows during seasonal and diurnal temperature changes, enhance security, and increase energy efficiency.
- Make sure the space is free of water and sewer pipes and valves that can burst or leak and cause damage. **Note:** Water lines associated with fire suppression systems are allowed. Spaces equipped with fire sprinkler systems should have adequate floor drain(s) with backflow check valve(s).
- Make sure space is free of electric junction boxes, gas and electric meters, and gas lines. This will limit the need for access by non-curatorial staff and minimize security concerns.
- Store only collections in the space. Local and national building codes usually rate collection storage space as "storage occupancy." Locate work, office, research, and supply storage areas close to, but not within, the storage space.
- Insulate the space so it will maintain a stable environment that protects the objects from adverse temperature and relative humidity conditions and damage from biological infestations. Insulate walls to a minimum R-19 rating (usually a 6" thickness of spun glass bat insulation) and the ceiling to a minimum R-30 rating (usually a 9" thickness of spunglass bat insulation). Install a vapor barrier in walls, ceilings, and floors.
- Require woodframe walls to be a minimum of 6" thick, constructed with 6" metal or wood studs. This thickness of wood-frame wall construction provides structural strength and is capable of accommodating the required insulation.
- Use metal hollow-core or wooden solid-core doors equipped with mortise or key-in-knob and deadbolt locks for all entrances into the storage space. Door hinges should be on the interior side of the door. If exterior hinges are used, spot weld hinge pins to prevent easy removal.

- Install rigid foam insulation and a vapor barrier in concrete floors on grade. Make sure the level of the top of the concrete slab is at least 6" above the grade level of the soil.
- Seal concrete floors with a vapor-proof epoxy or urethane paint or cover with dust impervious commercial composition, quarry or ceramic tiles. Use dust impervious commercial composition, quarry or ceramic tiles as a floor finish over plywood sub floor sheathing.
- Make sure all electrical systems and equipment are UL listed and installed in full compliance with local and national electrical codes. You will need outlets to power supplemental environmental conditioning equipment, to allow for any task lighting, and to allow for use of vacuum cleaners.
- Make sure the space is free of ambient light sources that can damage objects. Use non-quartz/halogen incandescent or UV filtered fluorescent lighting and do not exceed 200 lux or 20 footcandles. Turn lights off when the storage space is unoccupied.
- Paint walls and ceiling with paint containing titanium dioxide pigment. Paint with titanium dioxide will absorb ultraviolet radiation emitted by ambient or artificial lighting.

6. *What design loads should my storage space or facility have?*

Your storage facility or space should be designed or modified to meet the following requirements and recommendations:

- Use space capable of sustaining a live floor load of 150 pounds per square foot. Floors constructed to a lesser load capacity may be considered if you install spot load supports (usually post supports from below) and arrange equipment to take advantage of existing structural supports (usually equipment arranged around the perimeter of a room close to load bearing walls). Consult a structural engineer to determine the suitability of a floor and the placement of supports and equipment. A live floor load of 200-250 pounds per square foot is recommended if you use a moveable aisle (compactor) storage system. Consult a structural engineer to determine the required load rating for a floor supporting collections of exceptional weight.
- Design and construct roofs of storage spaces or facilities to accommodate the snow load of the area.
- Design or retrofit structures in areas of seismic activity to minimize earthquake damage.
- Consider reinforced concrete or masonry construction with a wind load rating of 110 miles-per-hour or higher for new construction of stand-alone storage facilities in areas susceptible to severe wind conditions. Fasten roofs to the wall and/or foundation structural components so the roof can withstand hurricane force winds.

7. *Where do I find additional information on storage space requirements?* Refer to the bibliography at the end of this chapter and the *Conserve O Gram* series for additional information and specific guidance for planning collection storage spaces.
8. *Why should my collection storage space be used exclusively for storing collections?* Separate curatorial office, work, and research spaces from the space housing your museum collection to minimize environmental impacts on the objects and security risks. Refrain from combining storage space with other functions for the following reasons:
- Collection security generally decreases; theft, mishandling, and vandalism increase with storage room visitation and use.
 - People working in the storage area increase the number of air exchanges the area must undergo. Air exchanges cause temperature and relative humidity levels to fluctuate, resulting in the possible deterioration of objects.
 - Work areas require lighting levels that may cause damage to unprotected light-sensitive objects.
 - Movement of people into and within the area tracks in soil and disperses dust into the air, which in turn, is deposited on surfaces of equipment and objects.
 - The chance of pest infestation increases.
- Store flammable liquids and materials, curatorial supplies, audiovisual equipment, and other interpretive materials outside the museum storage space. These actions will reduce the risk of fire and lessen clutter within the storage space.
9. *Where should I locate the research space?* Locate research space convenient to, but not within, the collection storage space. Research is one of the fundamental uses of a museum collection and the space for the research function has specific requirements. Refer to the *Museum Handbook*, Part III (*MH-III*), Appendix D: Guidance on Planning for a Research Space, for information on planning your research space.
10. *Where should I locate work and office spaces?* Like research space, work and curatorial office areas should be convenient to, but not included in, the storage space for the reasons stated in number 8 above.
11. *How do I establish proper physical security for the collection storage space?* Your collection must have appropriate security. You will need to conduct an assessment of the security risks to the stored collection. Refer to Chapter 9 of this handbook for details on conducting a risk assessment and for specific security guidance.
12. *How important is fire protection in the storage space?* Collection storage houses the majority of the museum collection and that space must be assured the safeguard of early fire detection and suppression and prior planning to guarantee the safety of the collection and the personnel who use and care for it. Refer to Chapter 9 of this handbook for information on conducting a fire risk assessment and for specific fire protection guidance.

13. *What should the collection storage environment be?*

Your storage space should maintain an environment conducive to museum object preservation. A proper collection storage environment is one that:

- controls the range of temperature and relative humidity
- reduces the fluctuations of temperature and relative humidity
- prevents damage resulting from air pollutants
- prevents damage resulting from light
- eliminates biological infestations by insect and rodent pests

Refer to Chapters 4 and 5 for guidance on monitoring and controlling the collection storage environment and on establishing an Integrated Pest Management (IPM) Program to monitor pest activity.

14. *What are museum storage equipment and container requirements?*

The use of specialized storage equipment and containers will help you preserve and effectively manage your museum collection. The use of proper storage cabinets, shelves, racks, and containers will make it easier to use the space and access the collection. Storage equipment will prevent damage from agents of deterioration. Appropriate storage containers buffer the objects from their immediate environment by being chemically stable and neutral and by providing physical protection. *NPS Tools of the Trade* provides a list of materials and equipment suitable for managing museum collections. It also provides a vendor address list. Refer to Section G and the bibliography of this chapter for specifics on collection storage equipment and containers.

15. *Does housekeeping have a role in collection storage?*

Yes. Because museum objects are stored in a separate dedicated space and not always on view to staff, there is always the possibility of neglect. Good housekeeping in storage spaces is essential to a park's preventive conservation program.

You should:

- Establish and follow a museum housekeeping plan. Refer to Chapter 13 and the ANCS+ User Manual for guidance on establishing a housekeeping plan.
- Prohibit smoking, eating, and drinking in the storage space.
- Implement and follow an IPM program.
- Routinely dust and vacuum the storage area including cabinets and shelving. Vacuum using a High Efficiency Particulate Air (HEPA) vacuum and dry mop floors to reduce levels of dust and soil.

C. Planning Collection Storage Space

1. *How should I plan my museum storage space?*

Planning for museum storage is essential to ensure maximum preservation and optimum access to the collection. Planning a collection storage space will help ensure that the necessary requirements are met. The process of collection storage planning may focus on:

- the development of a new facility
- the rehabilitation or upgrading of an existing space or facility
- a specific aspect of museum storage such as determining equipment and space requirements for a collection, determining a special layout of equipment, or outlining specific techniques for housing museum objects on shelves or in cabinets

In the National Park Service, the product of collection storage planning may be a Collection Storage Plan (CSP) or a chapter or section on museum collection storage in a Collection Management Plan (CMP), a Collection Condition Survey (CCS), or an archival assessment.

Regardless of the product, some or all of the elements of a CSP, described below, are incorporated into the planning process.

2. *What is a Collection Storage Plan (CSP)?*

A Collection Storage Plan (CSP) is an official stand-alone document developed to help a park or center improve the storage conditions for a museum collection. It may be prepared to solve specific storage problems, guide renovation of an existing space into collection storage, or guide the design of a new facility.

A CSP must include the following core elements:

- a determination of the size of storage space needed
- a determination and listing of specialized storage equipment needed
- a floor plan illustrating a recommended layout of equipment
- an assessment of object storage techniques and methods and recommendations for improvement
- a solution for park-specified or urgent storage problems

A CSP may also include the following:

- an assessment of the nature of the collection
- an assessment of the existing collection storage facility and/or space(s)

- an assessment of the existing storage conditions in comparison with NPS standards and requirements for storage
- identification and discussion of storage space alternatives

The specific nature of the collection and the availability of funding and staffing are factors to consider when selecting alternative storage options.

3. *What does the collection storage chapter or section of a CMP, CCS, or archival assessment contain?*

The storage chapter or section of a CMP, CCS, or archival assessment contains some or all of the elements of a CSP. However, it is incorporated into the larger report instead of being a stand-alone document.

4. *Who can write a collection storage planning document?*

For objectivity and diversity of views, NPS curatorial staff from outside the park usually prepare a collection storage planning document. You can also procure the services of a museum professional or architectural/engineering firm with expertise in collection storage planning.

Contact the regional or support office (SO) curator for guidance on writing a storage planning document. The Museum Management Program can provide examples of a CSP.

5. *How much does a storage planning document cost?*

Producing a basic CSP (incorporating the core elements) requires funds for:

- approximately 2-4 weeks of the preparer's time
- travel and expenses for a 1-2 week site visit
- printing and duplicating the document

To produce a CSP with more than the core elements will require additional time and increased costs.

Consult the Cost Estimates Figure in Appendix F: NPS Museum Collections Checklists, for a current estimated cost to produce a CSP or storage planning document.

6. *Where do I get funding to do a collection storage planning document?*

Possible funding sources to produce collection storage planning documents include:

- Cultural Resources Preservation Program (CRPP)
- Museum Collection Preservation and Protection Program (MCPPE)
- park or center base funding
- park cooperating association donation account
- special funding initiatives that may be announced

To obtain storage planning project funding, you must identify the need for a collection storage planning document:

- in the NPS Checklist for Preservation and Protection of Museum Collections using the Automated Checklist Program in *ANCS+*.

Identifying the need in the Checklist links the project to the NPS Strategic Plan (Goal Ia6) and the Government Performance and Results Act.

- as a project statement in the Resource Management Plan (RMP).
- as a project statement in the Performance Management Information System (PMIS).

D. Assessing Collection Storage Needs

1. *How do I assess the collection?*

To assess the collection:

- Examine the entire collection with emphasis on objects designated for storage. Also consider all objects that may eventually be placed in the storage space.
- Note the types of objects, the quantities of each object type, the relative sizes, and required volumes for storage. For example, consider a hammer and a wagon. Both are historical objects and are made of more than one material, however, each object has different storage requirements and containment needs.
- Note object types by discipline and material makeup. Note the types of objects that are extremely sensitive to the influences of temperature and relative humidity, light, and air pollution.
- Identify the types and approximate quantities of objects that the park plans to acquire in the future. Study the park's approved Scope of Collection Statement for this information. In addition, consider the return of outgoing loans and temporary transfers, and future archeological and natural science research projects that may increase the size of the collection.

2. *How do I assess physical security needs?*

Use the following guidance in assessing the physical security needs:

- Conduct a physical security risk assessment as described in Chapter 9.
- Note any extant intrusion alarm system (type, location of sensors, nature of monitoring, who responds, and response time) serving the space.

- Note the construction and locking mechanisms of doorframes and doors (metal, solid-core wooden, wooden hollow core, dead bolt locks).
- Note how windows are secured (latches, plywood-covered, bars).
- Identify the park staff who have keys to storage areas and park staff who require access but are not issued keys. Note whether staff members from other divisions need to enter or pass through the area to access major junction boxes or cleaning supplies.
- Note any other functions that occur in the storage space.
- If applicable, note any areas in the storage space where security is compromised. For example, is there easy access from an adjoining space such as through a dropped ceiling.
- Note if a visitor/researcher log is used and maintained.

3. *How do I assess fire protection needs?*

Use the following guidance in assessing the fire protection system:

- Conduct a fire protection risk assessment as described in Chapter 9.
- Note any extant fire protection system. Include type of system (wet pipe sprinkler, water mist, Halon™, ionization, smoke, heat activated) serving the space.
- Determine how the detection alarm is monitored, the responsible party for responding to an alarm, and the response time.
- Check to ensure that the park's Structural Fire Plan is current and consistent with *Director's Order #58: Structural Fire Guidelines*. The plan should clearly identify the pre-suppression actions for the responding authorities (for example, how to enter the storage space, or the priority list for evacuating objects).
- Identify the number, types, and locations of hand-held fire extinguishers. Check extinguisher inspection tags and labels to be sure extinguishers are maintained.
- Identify the closest water supply available to suppress a fire.

4. *How do I assess environmental monitoring and control needs?*

In order to assess the collection storage environmental needs:

- Become familiar with the information on environmental monitoring and control found in Chapter 4.
- Note the readings at the time of the site visit for temperature, relative humidity, and light levels of the existing space.
- Note the type of existing environmental monitoring equipment (hygrothermograph, hygrometer).

- Check to ensure that environmental monitoring equipment is properly calibrated and maintained.
- Examine the data recorded on temperature and relative humidity within the storage space. In particular, note the following information:
 - annual *maximum* and *minimum* temperature readings and relative humidity levels
 - monthly *maximum* and *minimum* temperature readings and relative humidity levels
 - maximum diurnal (24 hour) fluctuation for temperature and relative humidity on a *monthly* and an *annual* basis.
- Answer the following questions:
 - Do the records indicate the maintenance of a proper environment?
 - Do building features such as the climate control system (heating, ventilating, air-conditioning [HVAC]) or superior insulation and vapor barrier contribute to maintaining the environment?
 - Do the records indicate diurnal changes if HVAC equipment is turned off after working hours?
- Note the type of HVAC (air-handling) system in use (oil-fired furnace, heat pump, central air). Note whether the system is dedicated to controlling the environment within the storage space or the entire structure. In particular, note the following information:
 - location of the thermostat
 - location of air supply and return registers
 - how the air is filtered
- Obtain manufacturer's equipment operating manual. Determine maintenance history of equipment.
- If applicable, determine if portable dehumidifiers, humidifiers, or air-purifiers have had an impact on controlling conditions.
- Examine the data on visible and UV light levels in the storage space. Check fluorescent lighting to ensure that light filters are installed. Use an ultraviolet radiation monitor to take readings to ensure that filters are blocking ultraviolet light.
- If there are windows in the space, note if:
 - the staff recorded light levels for both winter and summer months
 - blinds, curtains, or light filters have been installed

- Note levels of dust and possible sources of dust. Note the types of dust covers used to protect objects stored on open shelving (for example, plastic, muslin).
- If available, obtain measurements for sulfur dioxide, hydrogen sulfide, and oxides of nitrogen from the Environmental Protection Agency or a local agency. Attempt to identify industry in the area that could produce pollutants that affect the collection. If appropriate, examine data available on pollutant readings from a number of years. Note any trends and describe the existing and potential threats to the collections.
- Note any current evidence and history of biological infestation. Determine if the park has an Integrated Pest Management program in operation. Note data that staff has recorded on types of pests in the traps.

5. *How do I assess museum storage equipment needs?*

Use the following guidance in assessing the storage equipment:

- List the types of existing storage equipment (museum storage and specimen cabinets, map cabinets, file cabinets, shelving, painting racks, specialty racks, high density storage systems). See *NPS Tools of the Trade* for equipment types and descriptions.
- Note the manufacturer and model number of each type of equipment. If the equipment is non-standard, note its size (width, depth, and height).
- Note the condition of the equipment (operation of locks, condition of gaskets, evidence of rust, dents, holes, scratches).
- List any equipment you will need to replace.
- Note if additional museum equipment is needed. Are there museum objects that need to be contained?
- Determine if you will need specialized equipment or adaptations to equipment to house specific types of objects or make more effective use of the space. For example, additional space might be provided by installing a high density storage system or by installing racks to make optimum use of vertical storage space or to store objects on a wall.
- Determine if a rearrangement of the equipment could better use the existing space.
- Note the types and numbers of equipment used to monitor temperature and relative humidity and types of portable equipment used to achieve required environmental levels.
- Note the type of equipment that is used in the housekeeping program for the space (vacuum cleaner, mops, buckets, brooms, dust mops).

6. *How do I assess object storage techniques and methods?*

Use the following guidance for assessing object storage techniques and methods:

- Note the condition and appropriateness of equipment used.
- Note how types of objects are organized in cabinets, racks and shelves. Indicate if objects are crowded or stacked.
- Note how individual objects are contained. Indicate whether containers are appropriate and provide adequate physical protection.
 - Are objects stable and set securely in their containers?
 - Are objects adequately cushioned to prevent them from moving or sliding when being accessed?
- Make recommendations for improving storage techniques.

You may wish to use the assessment worksheet and observation/recommendation codes in Figure 7.2 to simplify the assessment process. Refer to Figure 7.2a for a sample worksheet. Refer to Figure 7.2b for assessment codes.

7. *Where do I include technical supporting information and drawings such as floor plans in the storage planning document?*

Use appendices or attachments for technical information such as product/source information, environmental monitoring data, illustrations for constructing specialized equipment, and floor plans. Preparers should consult their regional/SO curator and the Museum Management Program for assistance in gathering material for appendices.

E. Assessing the Current Collection Storage Facility or Space

1. *How do I assess the existing storage facility or space?*

Examine the existing structure(s) and space(s) within each structure that are used for museum collection storage to identify how well they meet the storage standards:

- Note the structure's construction and fabric (wood, masonry, two-story, one-story).
- Record the overall dimensions of the space and the ceiling height and type (for example, 8' dropped ceiling).
- Note the number and size of access doors (measure all doors that objects will pass through).
- Determine, with the assistance of an architect or engineer, if the structure has the strength to safely withstand the loads associated with the collections to be stored. This is especially important for second floors in a structure. **Note:** Ceramics, metals, paper, glass, and wood objects in great volumes are very heavy.

- Note any characteristics of the structure that would hinder the movement of objects or equipment. Stairs impede the movement of objects, especially large and heavy ones. Such access routes also increase the risk of accidental breakage.
- Note sizes and directional orientation of windows and types of glazing (glass, Plexiglas™ [acrylic], Lexan™ [polycarbonate]).
- Note any electrical service and plumbing fixtures and determine if existing electric service has capacity for add-on functions such as air-conditioners, humidifiers, dehumidifiers, or additional lighting.
- Note wall coverings (dry wall, plaster, brick, paneling). Some wall coverings and construction are more fire-resistant and secure than others.
- Note type and location of light fixtures (incandescent, fluorescent, combination).

2. *How do I represent and record information about the storage space and structure?*

Prepare a floorplan that indicates the following information:

- dimensions and arrangement of storage areas, including structural features that may restrict arrangements of equipment and must be worked around (structural posts, beams, conduit, drains)
- location of doors, stairs, and windows
- location of electrical service (conduit, outlets, switches, fixtures, and panel boxes) and plumbing (pipes, valves, and drains)
- dimensions and existing location of museum specimen cabinets and shelving, including aisle widths
- location of fire detectors/suppression system detectors and sprinkler heads, and fire extinguishers, stand pipes, and any other fire protection equipment
- location of environmental monitoring and control equipment

Security systems and devices are generally not indicated on the floor plan because dissemination of the plan could jeopardize security.

Refer to Figures 7.3, 7.4, and 7.5 for sample floor plans.

F. Planning a New or Upgraded Storage Space

Use the information you gathered in your assessment of storage needs (Section D) and your assessment of the current storage space (Section E) to plan your new or improved storage space.

Only after you determine how much equipment you need and the space you need to house that equipment, can you adequately assess storage locations and spaces.

1. *How do I determine the storage equipment needed?*

Refer to *COG 4/10*, “Determining Museum Storage Equipment Needs,” for guidance on determining equipment needs.

2. *How do I determine how much space is needed to store my collection?*

Refer to *COG 4/11*, “Determining Collection Storage Space Requirements,” to determine your space requirements.

3. *What process do I use to evaluate potential storage locations?*

You will need to conduct a value analysis of the collection storage function if you find that your current storage space is too small to house the collection or if for other reasons the current space is unsuitable. See *Value Engineering Guideline (NPS-90)*, for information on conducting a value analysis. In simplest terms, a value analysis is the process of defining the problem, exploring solutions to the problem, and deciding on the best solution.

Policy requires that you complete a formal value analysis for renovations or new facilities costing over \$500,000. You may also do an informal value analysis for small- to medium-sized collection storage spaces costing less than \$500,000.

A value analysis includes an informational phase, a creativity phase, an evaluation phase, a development phase, and a recommendation phase.

The informational phase includes a full examination of the collection storage function. You will need to fully understand and state the needs of the collection storage function. The standards and requirements for collection storage should guide the informational phase.

4. *What storage space alternatives should be examined?*

The creativity phase presents alternatives for achieving the collection storage requirements. There are several alternatives that you will need to consider:

- Modify or retrofit the existing storage space.

This alternative may include upgrading the space with new environmental, fire protection, and security systems; installing insulation and a vapor barrier; or rearranging the storage equipment. Use floorplans and other drawings to represent changes to the space.

Also document previous records of any changes. Describe how existing conditions can be corrected to conform to NPS requirements.

See “Prototype Artifact Storage Structure – Instructional Package,” a NPS technical publication available from the Midwest Support Office. This publication guides a park in developing or upgrading storage space in an existing historic structure. The same instructions and information also apply in a non-historic structure.

Retrofitting may also involve the use of an insulated modular structure (see description in the NPS *Tools of the Trade*) and in Section G.2.

- Locate other storage spaces in the park.

This alternative involves looking at and evaluating other spaces in the building or other buildings in the park. Provide a description of the actions needed to adapt space(s) to conform to NPS storage requirements. You may use an insulated modular structure to adapt an alternate location into acceptable space. In each instance, gather and record the pertinent information you need to assess the appropriateness of the space. Use floorplans and other drawings to detail use of the space. Refer to Section E.2 for information to be recorded on the floorplan.

- Develop new space, either in a dedicated facility or combined with other park functions such as a visitor center or research center.

Use floorplans and other drawings to detail use of the space. Refer to Section E.2 for information to put on the floorplan.

- Investigate off-site storage in new or leased space.

Use floorplans and other drawings to detail use of the space. Refer to Section E.2 for information to put on the floorplan.

- Store the collections in a NPS center or regional repository.

You may house collections in off-site storage centers or repositories. Several NPS centers specialize in storing collections from archeological projects. These centers provide space and manage materials loaned from parks. The centers also conduct archeological research and provide scholars with access to the collections. The centers that specialize in archeological collections include the Southeast Archeological Center in Tallahassee, Florida, the Midwest Archeological Center in Lincoln, Nebraska, and the Western Archeological and Conservation Center in Tucson, Arizona.

Other repositories accommodate all types of collections. It may be necessary for you to store your collection off-site in a NPS regional repository when your park lacks:

- acceptable space to house objects safely
- qualified curatorial staff to provide day-to-day care for the collection

The National Capital Region and the Alaska Region operate repositories that provide space for the storage of museum collections from parks within the region.

- Store the collections at a university, college, museum or other non-NPS institution.

The regional/SO curator can assist in making arrangements with non-NPS repositories for the storage and curation of collections.

Institutions that house park museum collections must meet NPS standards and requirements for museum object preservation and protection. NPS collections should be clearly identified and kept as separate as possible from the institution's collection.

- Consolidate storage with another park.

You may find it necessary or advantageous to arrange to store your collection with a park that has available space and staff to care for it.

- Make no changes to the existing storage space.

You should list the reasons why your current storage area meets requirements or list possible consequences to the collection if your storage area does not meet storage requirements.

5. *What occurs in the evaluation, development, and recommendation phases of a value analysis?*

In the evaluation phase you assess alternatives for meeting the storage requirements. Consider all alternative locations for museum collections storage. Visit and examine each possible location and record pertinent data. Indicate the potential of each alternative space to satisfy the collection storage requirements. You may use the evaluation process used by the NPS called "Choosing by Advantages" at this phase. Incorporate start-up and life-cycle costs. It is important to document the alternatives you evaluate.

In the development phase, you *reevaluate* the best alternatives.

In the recommendation phase, you *select* the best alternative.

6. *What other storage factors should I consider?*

Consider the following when planning collection storage:

- Phase the project to allow improvements to occur as funding becomes available. For example, rehabilitate the space one year; install environmental control equipment and security and fire protection systems in the second year; purchase replacement and new equipment in the third year.
- Prepare appropriate programming documents. Refer to Chapters 1 and 12 of this handbook for guidance on NPS planning documents for programming and funding curatorial projects.
- Maintain and store only museum collections that are identified in the park's approved Scope of Collection Statement.

- Maintain museum collections for easy access by users. As a rule, the park can make better use of the collection if it is readily accessible on site.
- Store archival and manuscript collections in boxes on shelves or in folders in map cases (for oversize items). Don't store archive collections in file cabinets or fireproof cabinets.

G. Housing Museum Objects

1. *Why is it important to use specialized museum storage equipment?*

Museum storage equipment offers “front line” protection for museum objects. Specialized museum equipment provides physical containment and isolation from many of the factors that negatively affect object condition. Museum cabinets have synthetic gaskets that create an interior microenvironment that buffers temperature and relative humidity fluctuations, prevents insect and vermin infestations, and prevents damage caused by light, dust, and pollution. Shelving units provide physical protection for objects too large, awkward, or heavy to fit within museum cabinets. Specially designed racks accommodate and provide physical protection for hard-to-store objects. Special building systems are available for creating quality space inside other structures.

2. *What types of equipment does the NPS use for storing museum collections?*

Cabinetry

The NPS uses three primary types of cabinets to form a basic modular system that facilitates efficient organization and access to the objects. Refer to *COG 4/4*, “Modular Concept of Museum Specimen Storage Cabinets.” These three cabinets are the standard museum cabinet, the doublewide museum cabinet, and the wardrobe cabinet. In addition, there are entomology and herbarium cabinets, map cabinets, large flat storage cabinets, and utility cabinets. Refer to the NPS *Tools of the Trade* for descriptions and sources of available museum cabinetry.

Shelving

Several types of shelving are available. Refer to the NPS *Tools of the Trade* for descriptions, uses, and sources of available museum shelving. Steel shelving units, pallet racks, and slotted angle racks are frequently used. Steel shelving is recommended for boxed archival and manuscript collections. Pallet racks and slotted angle racks are particularly useful for storing furnishings and other larger, heavier items. Slotted angle racks are constructed using lengths of metal angle that can be custom cut. You can configure and construct a slotted angle rack for objects with specific support or space requirements. You can use metal panels or plywood coated with a water-based, two-component epoxy or water based aliphatic urethane paint for shelf decking.

Prefabricated Modular Structures

A prefabricated building system can be used to create a collection storage facility that is economical to construct, efficient to operate, and effective in creating appropriate environmental conditions. The building system is made of superinsulated, foam-core, metal-sheathed panels. It should be used only inside a host structure. Refer to NPS *Preservation Tech Note*, “Museum Collection Storage in an Historic Building Using a Prefabricated Structure;” *CRM Supplement*, “Collection Storage – Making a Case for

Microenvironments”; *COG 4/7*, “Museum Collection Storage Space: Is an Insulated Modular Structure Right for your Collection?”; and *COG 4/8*, “Selecting Environmental Control Systems for Insulated Modular Structures,” listed in the bibliography of this chapter. These publications provide discussions and give guidance in using this special building system for museum storage. The NPS *Tools of the Trade* provides information on sources for this building system.

3. *What are some general considerations when using museum equipment?*

Consider the following when using museum storage equipment:

- In planning for cabinets and shelving, examine all objects in the collection. To the extent possible, organize objects by material type and size rather than by provenience or accession/catalog information.
- Ideally, do not install cabinets and shelving units against exterior walls. This arrangement may lead to condensation inside the cabinets.
- Ensure that museum cabinets are free of rust, have intact gaskets to provide good sealing action, have smooth operating doors, and have working keyed or combination lock mechanisms. Early museum specimen cabinets used polyurethane foam gaskets that deteriorate over time or felt gaskets that may contain toxic insecticides. You should replace these gaskets. See *COG 4/3*, “Installing the Retrofit Gasket Kit.”
- Keep loads in museum cabinet drawers below 50 pounds. Don’t stack museum cabinets more than two high. Raise museum cabinets and shelving units off the floor at least four inches (preferably six inches). Raising cabinets off the floor reduces the chances of damage to objects in case of flooding. It also facilitates the cleaning of floors and inspection for pests.
- Use closed-cell polyethylene foam in museum cabinet drawers and on shelving to cushion objects. Prevent museum objects from sliding or shifting when drawers are opened by stabilizing objects in specimen trays, by padding with foam, or by cavity packing. Refer to the NPS *Tools of the Trade* for sources of foam and museum specimen trays.
- Assign and affix a unique number to all shelving units, individual shelves, cabinets, and individual cabinet drawers. This will help you locate museum objects.

H. Using Containers and Supports

1. *Why is it important to use storage containers and supports?*

Museum storage containers and supports provide a buffer between the object and its immediate environment. Archival quality containers and supports not only increase the level of preservation, but also can help organize the collection.

2. *What kinds of containers and supports should I use for storing museum collections?*

Boxes

Archival boxes come in a variety of types, shapes, and sizes. Most are made of acid-free, buffered board. Inert, corrugated, polypropylene or polyethylene boxes are often used to store archeological materials. (The corrugated plastic boxes are stronger and give additional protection from water damage.)

Archival boxes can be used to store records, artifacts, rare books, documents, prints, photographs, and textiles. See *Museum Handbook*, Part I (*MH-I*), Appendices J, K, and R, and *Tools of the Trade*.

Specimen Trays

Specimen trays are made of buffered, acid-free board. They can be used to hold artifacts and natural history specimens in museum cabinets and for layered storage in archival boxes. A variety of sizes are available.

Alkaline-buffered paper can damage pigments and proteins in bird and mammal specimens. Use unbuffered, acid-free materials, or line buffered trays with polyethylene sheeting (to block the direct migration of alkalis). See *MH-I*, Appendix T and *Tools of the Trade*.

Folders

Archival folders are composed of acid-free, buffered cardstock material and are used to house and protect historic documents. Folders come in many types, including: file folders (both letter and legal size), manuscript folders, and map folders for oversize items. See *MH-I*, Appendix J and *Tools of the Trade*.

Photo Enclosures

Photo enclosures of acid-free unbuffered paper are used to house photographic prints and negatives. Various sizes and varieties including sleeve type (sealed on three sides) and folding type (4 fold) are available. See *MH-I*, Appendix R and *Tools of the Trade*.

Bags

Polyethylene interlocking “zipper” seal bags can be used to house archeological materials and other small artifacts for storage in archival boxes and cabinets, for cold storage of some photographic materials, and as protection from pests. (Avoid the use of bags developed for food storage and home use because of printing inks and dyes. Bags for the storage of museum objects are available through *Tools of the Trade*.) See *MH-I*, Appendix I and *Tools of the Trade*.

Liners

To protect objects from coming into contact with metal drawers or shelves, a ¼"-thick polyethylene foam such as Volara® or Plastazote® may be used as a liner. This foam is inert, closed-cell, and resistant to moisture. See *Tools of the Trade*.

Cavity Packing

Polyethylene foams can also be used to cavity pack certain objects. Cavity packing creates secure compartments for objects. Spaces the size and shapes of the objects are cut from the foam to restrict movement and give support and easy access. See *MH-I*, Appendix I and *NPS Tools of the Trade*.

Cradle Mounts

Polyethylene foams are also used to create cradle mounts. These mounts are used to support structurally weak objects in order to alleviate stress on the weakest points. The foam is cut to the shape of the object and gives it a secure base to rest on. See *MH-I*, Appendices I and P.

3. *Where do I find information on techniques for storing different types of museum objects?* The appendices in this handbook and the *Conserve O Gram* series address the curatorial care of different types of objects, specimens, and archival collections. The appendices provide guidance on techniques for housing museum objects in storage. The selected bibliography included in each appendix provides additional references for the care and storage of each type of material. *Tools of the Trade* and the appendices list the recommended materials to use. Figures 7.6–7.11 illustrate some of the equipment and techniques for storing museum objects.

I. Storage of Museum Collections Subject to the Native American Graves Protection and Repatriation Act of 1990 (NAGPRA)

1. *What is NAGPRA?* The Native American Graves Protection and Repatriation Act of 1990 (25 USC Chapter 32) addresses the rights of lineal descendants, culturally affiliated Indian tribes (including Native Alaskan villages or corporations), or Native Hawaiian organizations to certain Native American human remains, funerary objects, sacred objects, and objects of cultural patrimony with which they are affiliated. The law requires federal agencies and museums that receive federal funds to:
- conduct inventories and summaries of such items in their collections
 - repatriate (return) items identified pursuant to NAGPRA to the appropriate lineal descendants, culturally affiliated Indian tribes, or Native Hawaiian organizations if requested

Items repatriated pursuant to NAGPRA must be deaccessioned in accordance with Museum Handbook, Part II (MH-II), Chapter 6, Section N: Native American Graves Protection and Repatriation Act.

For additional information concerning NAGPRA, see *MH-I*, Appendix A, *MH-II*, Chapter 6, Section N, and *Cultural Resource Management Guideline*, Appendix R.

2. *What types of items subject to NAGPRA are found in NPS museum collections?*

Your park's museum collection may contain items subject to NAGPRA, such as human remains, pottery, beads, prayer bundles, clothing, weapons, pipes, or other funerary, sacred, and cultural objects that are determined to belong to one or more lineal descendants, Indian tribes, Native Alaskan villages or corporations, or Native Hawaiian organizations. The culturally affiliated organization or lineal descendant with standing may request the repatriation of these items.

The individual, tribe, or organization requesting repatriation may be unable to take immediate possession of the materials, or they might prefer that certain items continue to be housed at your park. Under these circumstances, the individual, tribe, or organization with standing may want to be involved in determining how the items are preserved and stored at your park. Park management and staff will need to consult with parties with standing. Confer with your park and regional NAGPRA coordinator once such a request is made.

3. *Are there any special storage requirements for items subject to NAGPRA?*

You should treat collections subject to NAGPRA with great sensitivity, because of their cultural significance, sacred importance, and the fact that many of these materials were collected without the consent of descendants, tribal leaders, elders, or traditional religious leaders.

Because of their special status, you may need to separate collections subject to NAGPRA from other museum collections. Consult with the lineal descendants, culturally affiliated Indian tribes, Native Alaskan villages or corporations, or Native Hawaiian organizations concerning access, storage, and use. Accommodate the affiliated organizations' or descendants' requirements where possible, and institute any needed revisions to your park's Museum Collection Access Procedures, planning documents, and standard operating procedures.

4. *How should I store collections subject to NAGPRA?*

Protect collections subject to NAGPRA from fire, theft, pests, and environmental and other threats as you would any other museum object. However, you may need to use additional and/or alternative handling and storage methods and materials to show sensitivity and proper respect for these items in accordance with the affiliated individual's or group's request.

Consult with the lineal descendants or culturally affiliated organization with standing. Ascertain their preferences related to proper handling and storage techniques and materials, and defer to their wishes where possible. You may be asked to use some of the following storage methods, procedures, and materials when caring for culturally affiliated items:

- Store human remains aligned in a particular direction (such as the cranium toward the east).
- Construct special storage containers (possibly using wood, plant, or animal products native to the tribe's homeland).
- Ensure that only organic materials touch the items. Possible methods to avoid direct contact with archival foams include:
 - covering the foam's surface with archival tissue paper or unbleached muslin
 - wrapping the item in archival tissue paper or unbleached muslin
- Store newly collected natural plant materials (such as bundles of tobacco) with the items. (You can construct special outer enclosures or boxes to house these materials separately from other collections and to protect against pest infestations.)
- Allow tribal members access to storage areas for relevant religious or ceremonial purposes. This may include actions to protect:
 - individuals working with or viewing the items
 - the facility, collections, and items from a negative force

These are just a few of the possible techniques and procedures that you may be asked to follow with items subject to NAGPRA. This list is not all-inclusive or universal, as one tribe's methods may not be appropriate for another. **Consult with the lineal descendants or culturally affiliated organization with standing for guidance.**

Be sure to document all new or revised procedures and guidelines for handling, storage, and use of collections subject to NAGPRA following the consultation process. This may include notations, additions, or revisions to catalog records, catalog or accession folders, planning documents, access procedures and other standard operating procedures, or other relevant park documents.

5. *Whom should I contact for assistance?*

Contact your regional NAGPRA liaison, regional/SO curator, regional ethnographer, or local tribal members for assistance. **Before you begin the consultation process, determine the proper protocol and be sure to follow it whenever you contact tribal authorities, council members, elders, and traditional religious leaders.** (Your regional NAGPRA liaison, regional/SO curator, regional ethnographer, or local tribal members can assist you with issues of protocol.)

Consult with the lineal descendant, tribe, or culturally affiliated organization with standing concerning proper handling and storage guidelines, appropriate storage materials, and other procedures related to collections subject to NAGPRA at your park.

Many tribal governments have cultural resource management specialists, NAGPRA coordinators, museum staff, or archeologists who can help you. Contact your regional NAGPRA liaison, regional/SO curator, regional ethnographer, or the appropriate tribal headquarters for contact information.

When you ask for help or guidance during the consultation process, members of the culturally affiliated organization may not provide it willingly because the discussion of such topics may be offensive or uncomfortable for them. Even within one tribe there may be different views on procedures. Be aware that this might happen and always show proper respect for these views.

J. Bibliography

- Albright, Gary. "Storage Enclosures for Photographic Prints and Negatives." *Conserve O Gram* 14/2. Washington, D.C.: National Park Service, 1993.
- Bellman, Deborah. "Ring Supports for Pottery and Round-Based Objects." *Conserve O Gram* 4/12. Washington, D.C.: National Park Service, 1998.
- Chapman, Jennifer. "Storing and Handling Plaster Objects." *Conserve O Gram* 8/2. Washington, D.C.: National Park Service, 1997.
- Clark, Thurid. "Storage Supports for Basket Collections." *Conserve O Gram* 5/1. Washington, D.C.: National Park Service, 1993.
- Cumberland, Donald R. "Museum Collection Storage in a Historic Building Using a Prefabricated Structure." *Preservation Tech Notes* 1. Washington, D.C.: National Park Service, 1985.
- _____. "Collection Storage: Making a Case for Microenvironments." *CRM Supplement* 1, no. 4. Washington, D.C.: National Park Service, 1992.
- _____. "Museum Storage Cabinets." *Conserve O Gram* 4/1. Washington, D.C.: National Park Service, 1993.
- _____. "Dust Covers for Open Steel Shelving." *Conserve O Gram* 4/2. Washington, D.C.: National Park Service, 1993.
- _____. "Installing the Retrofit Gasket Kit." *Conserve O Gram* 4/3. Washington, D.C.: National Park Service, 1993.
- _____. "Museum Collection Storage Space: Is an Insulated Modular Structure Right For Your Collection?" *Conserve O Gram* 4/7. Washington, D.C.: National Park Service, 1994.
- _____. "Selecting Environmental Control Systems for Insulated Modular Structures." *Conserve O Gram* 4/8. Washington, D.C.: National Park Service, 1994.
- _____. "Determining Museum Equipment Storage Needs." *Conserve O Gram* 4/10. Washington, D.C.: National Park Service, 1993.
- _____. "Determining Museum Storage Space Needs." *Conserve O Gram* 4/11. Washington, D.C.: National Park Service, 1997.

- _____. "Planning A Research Space." *Conserve O Gram* 4/14. Washington, D.C.: National Park Service, 1998.
- _____. *Executive Order 11988. Floodplain Management*, May 24, 1977, (44 CFR 60.3).
- Fisher, Abby Sue, and Quinn Evans/Architects. "Prototype Artifact Storage Structure: Instructional Package." NPS *Technical Publication*: National Park Service and Quinn Evans/Architects, 1996.
- Guynes, David, and Kim Robinson. "Creating A Microenvironment for Oversized Museum Objects." *Conserve O Gram* 4/4. Washington, D.C.: National Park Service, 1993.
- Hall, Kathy. "Storage Concerns for Geological Specimens." *Conserve O Gram* 11/2. Washington, D.C.: National Park Service, 1998.
- Hilberry, John D., and Susan Kalb Weinberg. *Museum Collection Storage*, *Museum News* (May 1995) 7-21; (June 1995) 5-23; and (July 1995) 49-60. Washington, D.C.: American Association of Museums.
- Johnson, E. Verner, and Joanne C. Horgan. *Museum Collections Storage*. Paris, France: United Nations Educational, Scientific, and Cultural Organization (UNESCO), 1979.
- Johnson, E. Verner, and Joanne C. Horgan. *Planning and Design of Museum Collection Storage Facilities*, Boston: E. Verner Johnson and Associates, Inc., 1990.
- Knapp, Anthony M. "Storage Techniques for Canoe Paddles and Long Handled Tools." *Conserve O Gram* 4/6. Washington, D.C.: National Park Service, 1994.
- Knapp, Anthony M. and Pam West. "Storage Screens for Paintings." *Conserve O Gram* 12/1. Washington, D.C.: National Park Service, 1993.
- Kilby, Virginia. "Buffered and Unbuffered Storage Materials." *Conserve O Gram* 4/9. Washington, D.C.: National Park Service, 1994.
- Lewis, Ralph H. *Manual for Museums*. Washington, D.C.: National Park Service, 1976.
- Merritt, Jane. "Storage Techniques for Hanging Garments: Padded Hangers." *Conserve O Gram* 4/5. Washington, D.C.: National Park Service, 1994.
- Montgomery, Allan L. "Modifying Museum Storage Cabinets." *Conserve O Gram* 4/13. Washington, D.C.: National Park Service, 1998.
- National Fire Protection Association. *NFPA 101, Life Safety Code, 1997 Edition*. Quincy, Mass.: NFPA, 1997.
- _____. *NFPA 909 Standard for the Protection of Cultural Resources including Museums, Libraries, Places of Worship, and Historic Properties*. 1997 ed. Quincy, Mass.: NFPA, 1997.
- National Park Service. *Director's Order #58: Structural Fire Management*. Washington, D.C.: National Park Service, 2001.
- _____. *Floodplain Management and Wetland Protection Guidelines*. Washington, D.C.: National Park Service, 1997.
- Occupational Safety and Health Administration. *OSHA Standard 1910.36, General Requirements, Means of Egress*. Washington, DC: OSHA, n.d.
- Ritzenthaler, Mary Lynn. *Archival Fundamental Series: Preserving Archives and Manuscripts*, Chicago: Society of American Archivists, 1993.

- Rose, Carolyn L., and Amparo R. de Torres, eds. *Storage of Natural History Collections: Ideas and Practical Solutions*. Washington, D.C.: Society for the Preservation of Natural History Collections, 1992.
- Rose, Carolyn L., Catharine A. Hawks, and Hugh M. Genoways, eds. *Storage of Natural History Collections: A Preventive Conservation Approach*. Washington, D.C.: Society for the Preservation of Natural History Collections, 1995.
- Sullivan, Brigid. "Protecting Museum Collections in Storage." *Local History Notebook* 6, no. 2 (May/June, 1990). Columbus, Ohio: The Ohio Historical Society.
- _____. "Storage Mounts for Feathered Headdresses and Soft-Sided Hats and Caps." *Conserve O Gram* 5/2. Washington, D.C.: National Park Service, 1993.
- Vogt-O'Connor, Diane. "Caring for Blueprints and Cyanotypes." *Conserve O Gram* 19/9. Washington, D.C.: National Park Service, 1995.
- _____. "Housing Archival Paper-Based Materials." *Conserve O Gram* 19/16. Washington, D.C.: National Park Service, 1996.
- _____. "How to Care for Bound Archival Materials." *Conserve O Gram* 19/18. Washington, D.C.: National Park Service, 1996.
- _____. "Storing Archival Paper-Based Materials." *Conserve O Gram* 19/15. Washington, D.C.: National Park Service, 1996.

K. List of Figures

Figure 7.1	Levels of Containment in a Collection Storage System	7:29
Figure 7.2a	Example Assessment Worksheet	7:29
Figure 7.2b	Assessment Codes for Collection Storage Techniques.....	7:30
Figure 7.3	General Floor Plan of Proposed Museum Collection and Library Center at Grand Canyon National Park.....	7:32
Figure 7.4	Floor Plan of Proposed Museum Collection Space at Grand Canyon National Park	7:33
Figure 7.5	Floor plan of Museum Collection Storage Room at Voyageurs National Park (Scale: ¼"=1'0")	7:34
Figure 7.6	Cavity Storage.	7:35
Figure 7.7	Textile Storage.....	7:35
Figure 7.8	Large Objects Housed on Steel Shelving	7:36
Figure 7.9	Map Cabinet	7:36
Figure 7.10	Racks for Large Objects	7:37
Figure 7.11	Painting Storage.....	7:37

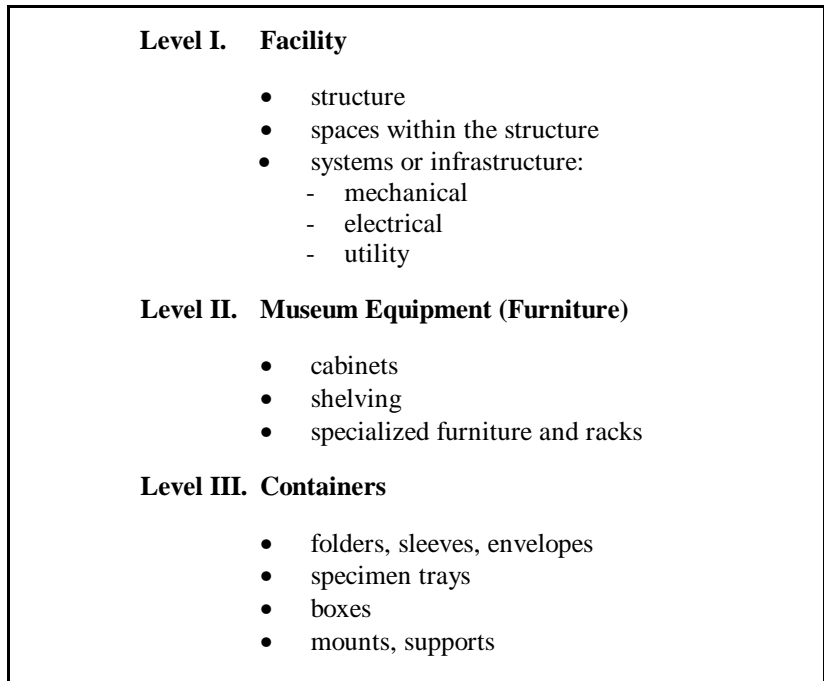

Figure 7.1. Levels of Containment in a Collection Storage System

FINDINGS AND RECOMMENDATIONS FOR UPGRADING STORAGE TECHNIQUES FOR EXISTING STORAGE UNITS		
<u>Storage Unit/Type</u>	<u>Drawer/Shelf</u>	<u>Corrections</u>
<u>Cabinet</u>		*
Standard Cabinet	1.....	M,O
	2.....	M,X
	3.....	*
	4.....	N
	5.....	K
	6.....	U
<u>Cabinet 2</u>		*
Standard Cabinet	1.....	*
	2.....	M,O,X
	3.....	X
	4.....	M
	5.....	X
	6.....	*
<u>Cabinet 3</u>		A
Standard Cabinet	1.....	*
	2.....	J
	3.....	K,S
	4.....	K,S

Figure 7.2a. Example Assessment Worksheet

Assessment Code

Cabinet/Shelving Unit Specific (indicate cabinet or shelving type.)

- A Gasket is damaged, wrong type, or ineffective. Install retrofit gasket kit. See *COG 4/3*.
- B Cabinet has no lock. Install sash lock or other locking device.
- C Cabinet or unit is damaged. Repair or replace as required.
- D Cabinet or unit is dusty or dirty. Vacuum or wipe interior and exterior of cabinet or unit.
- E Cabinet or unit paint surface is chipped, scratched or rusty. Repaint with water-based urethane or epoxy paint.
- F Cabinet is directly on floor or shelving unit bottom shelf is not adequately raised off the floor. Raise cabinets on platforms, appliance rollers, or caster bases so that they are 2"–6" off the floor. Adjust shelving unit bottom shelf to be at least six inches off the floor.
- G Wooden rack or shelving unit components are unsealed. Seal with water-based urethane or epoxy paint.
- H Drawer slipping through glides. Install water-based urethane or epoxy painted metal shims on vertical surfaces of drawer glides to center drawers.
- I Shelving unit in earthquake zone lacks shelf retainers. Install shelf retainers to prevent objects from shaking off shelves.
- J Objects in open or on shelving units are coated with dust. Install dust covers (See *COG 4/2*).

Drawer/Shelf Specific

- K Objects are loose and unprotected in drawers or on shelves. Place objects in specimen trays and/or cavity pack.
- L Objects too large for specimen trays rest directly on drawers or shelves. Place polyethylene foam pads under objects to form an inert cushioned surface on which the objects can rest.
- M Objects in cabinets or on shelving are unstable and are in danger of damage by sliding or rolling. Pad, cavity pack, or cushion objects with appropriate tissue or foam.
- N Objects are stacked and/or overcrowded. Rearrange or move objects to allow adequate separation.
- O Weight of objects exceeds 50 pound drawer limitation. Remove objects as needed.
- P Objects stored in inappropriate cabinet or rack. Place objects in appropriate cabinet, rack, or shelving unit as indicated.

Figure 7.2b. Assessment Codes for Collection Storage Techniques

Object Specific

- Q Documents or books are loose and unprotected. Place documents in archival folders or envelopes and then in document boxes. Place books in rare book boxes (see *COG* 19/2). Place document or rare book boxes in cabinet or on shelving.
- R Photo positives and negatives are loose and unprotected. Place photos in appropriate archival photo enclosures and in photo enclosure boxes. Boxes can be placed in cabinets or on shelving. See *COG* 4/9 and *Tools of the Trade* for appropriate usage of enclosures.
- S Maps and oversized prints are stored loose and unprotected. Place objects in appropriately sized archival map folders (blueprints and cyanotypes go only in unbuffered folders) and store flat in appropriate cabinet. See *COG* 19/9.
- T Framed artwork is stored horizontally or stacked leaning against each other. Place artwork on a rack that will separate pieces and store them vertically. See *COG* 12/1. Use dust covers.
- U Unframed artwork and large documents are stored loose and unprotected. Interleave items with archival bond paper and place in print boxes. Boxes can be stored either in cabinets or on shelving.
- V Artwork framed with acidic matboard. Consult with conservator regarding rematting with archival matboard.
- W Organic and inorganic materials are stored in close proximity. Separate dissimilar materials (e.g., metals from proteinaceous organics, such as leather, fur, silk) and store materials with similar requirements together (ideally in cabinets devoted to each material type).
- X Objects stored in containers or labeled with tags made of acidic materials. Replace acidic containers or tags with ones made of archival materials.
- Y Objects have active deterioration, mold or physical damage. Conservation survey should be requested.
- Z Evidence of pest infestation observed. Integrated Pest Management program needs to be implemented or improved.
- XX Other as indicated
- * Proper Storage

Figure 7.2b. Assessment Codes for Collection Storage Techniques (continued)

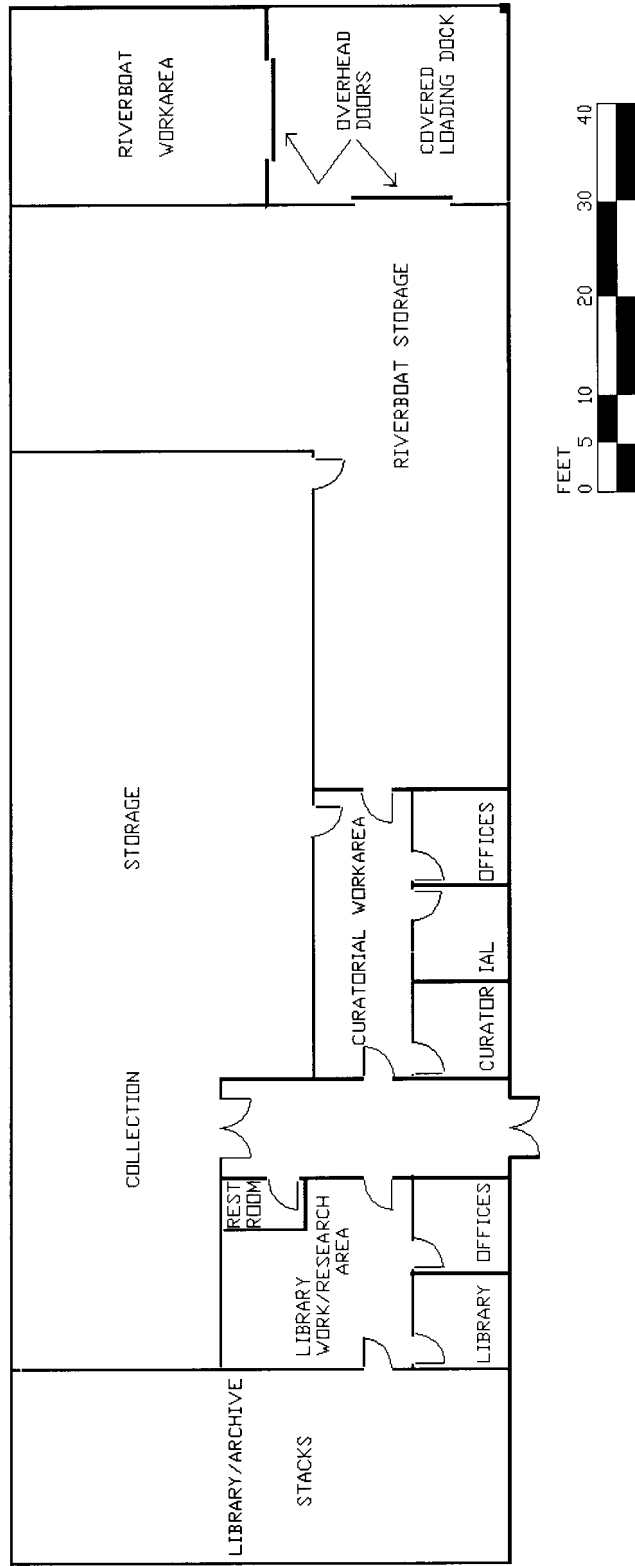

Figure 7.3. General Floor Plan of Proposed Museum Collection and Library Center at Grand Canyon National Park. *Drawn with AutoCAD® Computer Assisted Design Program.*

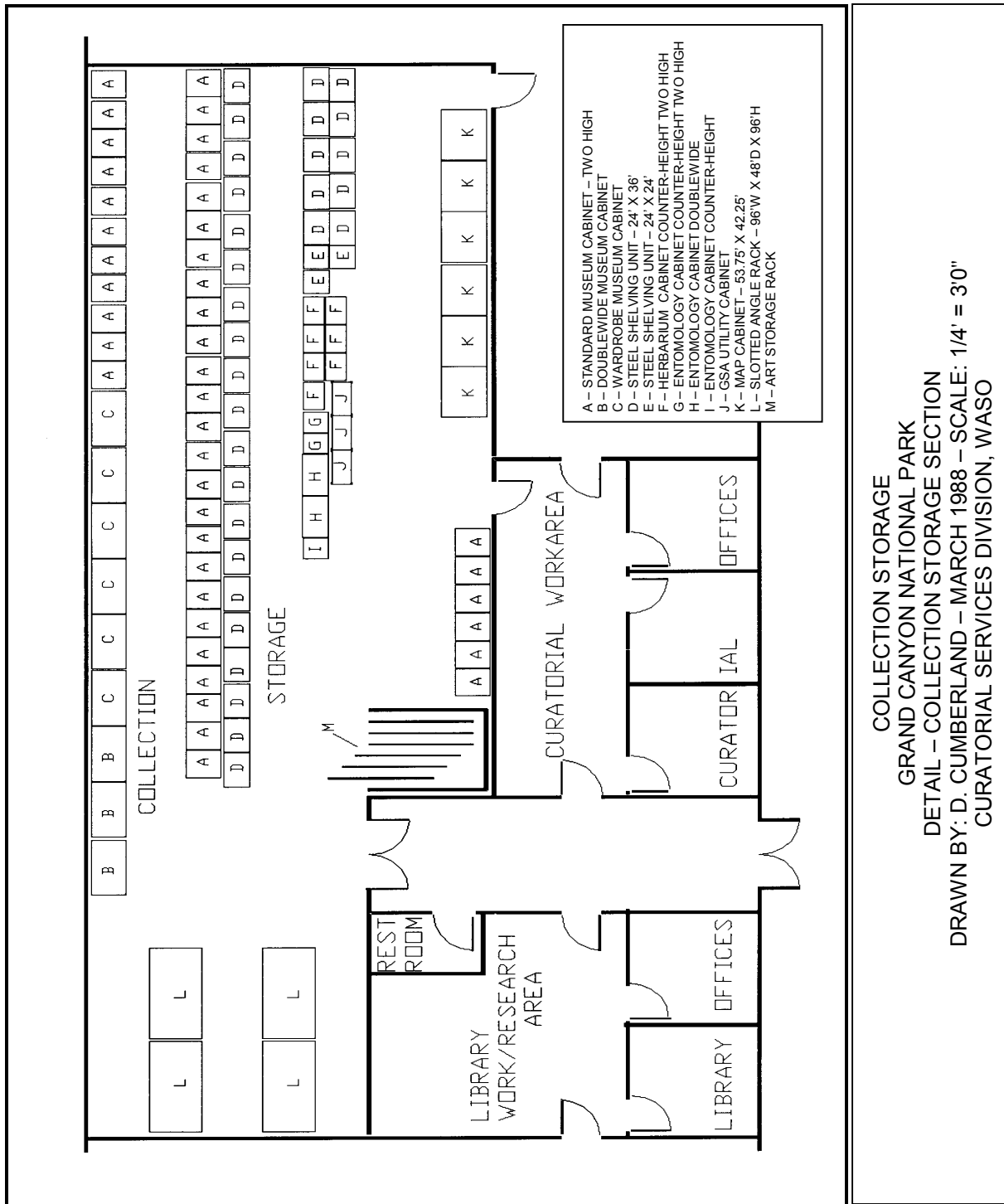

Figure 7.4. Floor Plan of Proposed Museum Collection Space at Grand Canyon National Park. *Drawn with AutoCAD® Computer Assisted Design Program.*

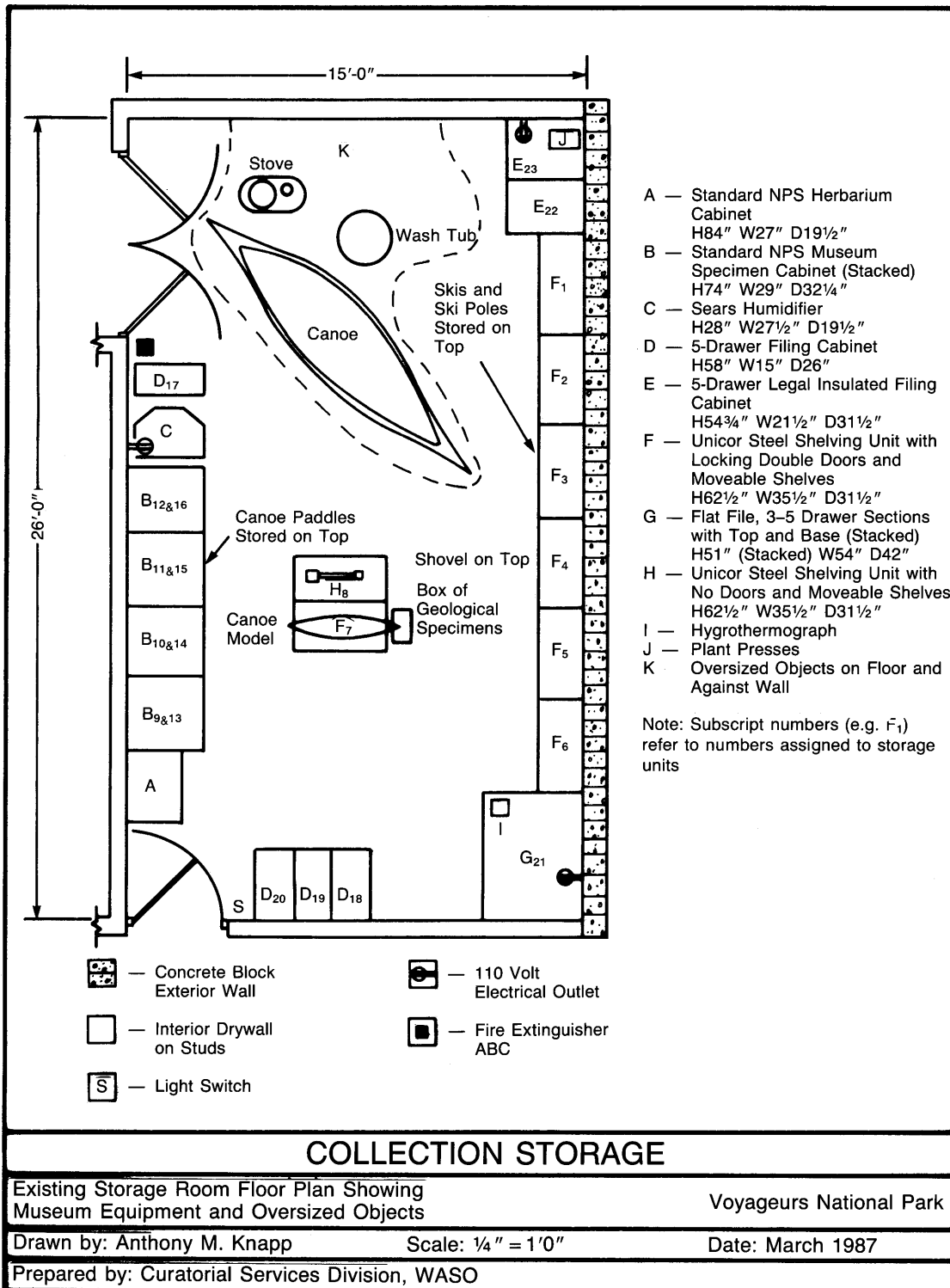

Figure 7.5. Floor Plan of Museum Collection Storage Room at Voyageurs National Park (Scale: 1/4"=1'0").
Floor plan shows existing museum equipment and oversized objects.

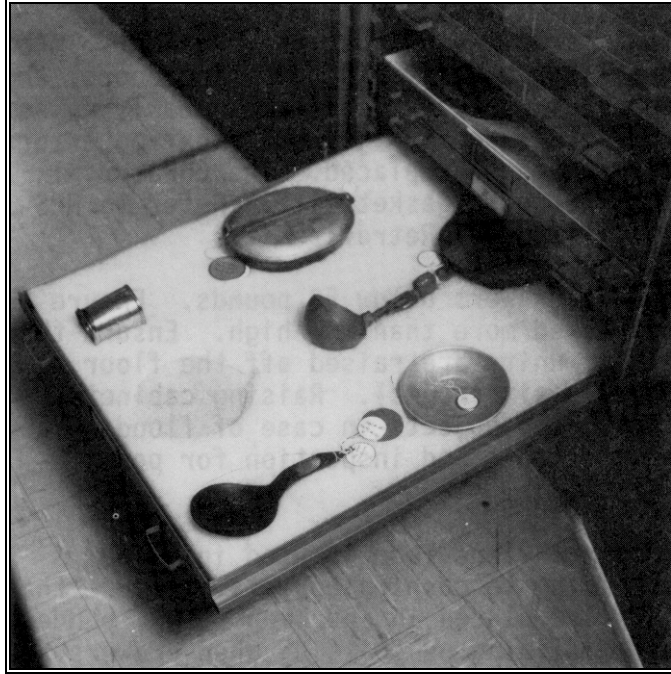

Figure 7.6. Cavity Storage. *Use cavity storage techniques to house small objects in a standard museum cabinet drawer.*



Figure 7.7. Textile Storage. *Wardrobe museum cabinet storage assemblies for rolled textile objects.*



Figure 7.8. Large Objects Housed on Steel Shelving. *Note that the metal surfaces are lined with polyethylene foam. Both plastic and muslin dust covers can be used to protect objects from dust.*

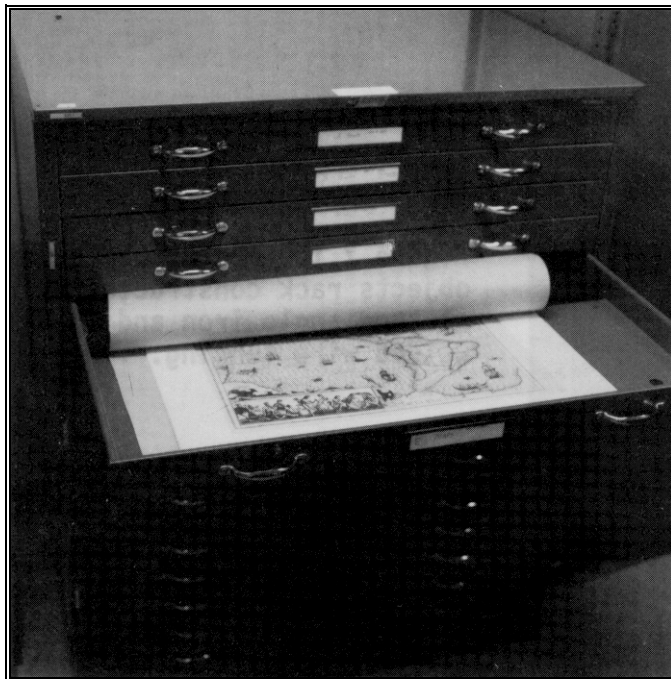

Figure 7.9. Map Cabinet. *A five-drawer map cabinet with a map enclosed in an acid-free document folder.*

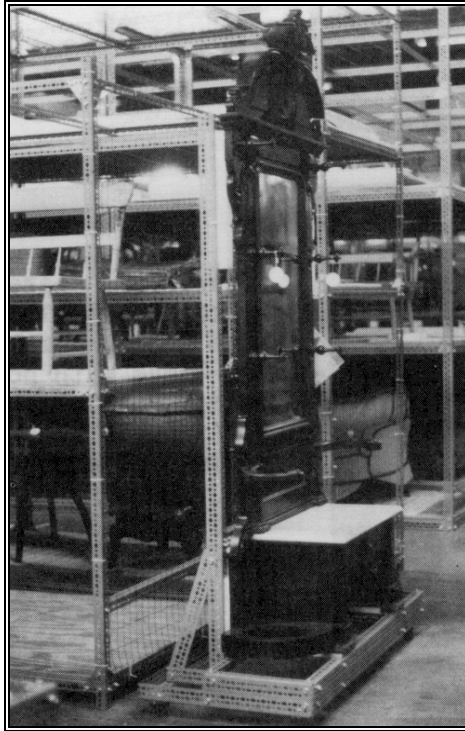

Figure 7.10. Racks for Large Objects. *Slotted angle iron can be used to construct racks for furniture and other large objects. This versatile material also can be used to fabricate custom designed storage equipment such as the rolling unit for the hallstand shown in this figure.*

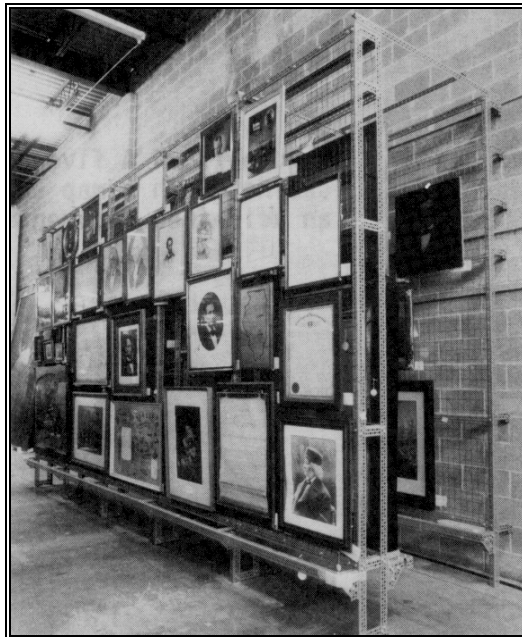

Figure 7.11. Painting Storage. *Painting and framed-objects rack constructed of slotted angle iron and 2" mesh welded wire fencing.*

Chapter 8: Conservation Treatment

A. Overview	8:1
What is treatment?	8:2
What is preservation?	8:2
What is conservation treatment?	8:2
What is stabilization?	8:3
What are restorations?	8:3
Why use reproductions?	8:3
Why should treatments be reversible?	8:3
What NPS guidance is available to help me make decisions about conservation treatment?	8:4
When do I need a conservator?	8:4
B. Factors to Consider Before Conservation Treatment	8:4
How will I know what conservation treatment is appropriate?	8:4
What guidelines should I follow when considering restoration?	8:6
What is the difference between conservation treatment and routine maintenance?	8:6
C. Documentation of Conservation Treatment	8:7
Why is conservation documentation important?	8:7
What is the ANCS+ Conservation Associated Module?	8:7
What types of conservation projects can be recorded in the Conservation Associated Module?	8:8
What kinds of documentation should I require from the conservator?	8:9
What are typical documentation steps when an object is treated?	8:11
What kinds of documentation should park staff generate on its own treatment activities?	8:11
D. Obtaining the Services of a Conservator	8:12
How do I find a conservator?	8:12
How do I decide if a suggested conservator and treatment are suitable?	8:13
What do I need to know about contracting for conservation treatment services?	8:14
What happens after the conservator is selected?	8:14
When I am evaluating a treatment proposal, what should I consider?	8:14
What are my responsibilities once the treatment proposal is approved?	8:15
Where can I find information on how to treat objects in an emergency?	8:15
E. Glossary	8:15
F. Selected Bibliography	8:16
G. Internet Resources	8:17
List of Figures	
Figure 8.1. Information Required in Conservation Treatment Documentation	8:10
Figure 8.2. Sample Narrative Examination Report	8:18
Figure 8.3. Sample Treatment Proposal	8:20
Figure 8.4. Sample Treatment Report	8:22

CHAPTER 8: CONSERVATION TREATMENT

A. Overview

This chapter explains how to get appropriate conservation treatments by experts in the conservation field. Care of NPS museum collections is based on a preventive conservation approach to preserve objects, archives, and natural history specimens. Sometimes, however, preventive measures are inadequate, and conservation treatment is necessary to preserve an object:

- If an object has inherent vice, preventive measures may not be enough to reduce the rate of deterioration to a tolerable level. An acceptable treatment can prolong the life of an object. For example, a paper conservator can wash deteriorated wood-pulp paper to remove acidic by-products.
- If an object is extremely fragile from deterioration, appropriate treatment can increase stability and durability. For example, a paintings conservator can reattach flaking paint.
- If an object will be used for exhibit, research, or publication needs, conservation treatment may be needed. For example, a textile conservator can construct a special mount for a flag to allow it to be exhibited vertically. An archeological conservator can clean a metal artifact to reveal important markings.

Conservation treatment is active ("hands-on") work to preserve and/or restore objects. Only trained conservators who have experience in the appropriate material (for example, paintings, textiles, furniture, photographs, books, paper, archeological objects, ethnographic objects, natural history specimens) should treat the objects.

If conservation treatment is required, the park staff must ensure that:

- objects, archives, and specimens receive the most appropriate treatment for their preservation and use
- treatment is appropriate by considering an object's condition, history, significance, and use
- treatments are performed by skilled, experienced conservators and documented properly

Anyone who carries out a treatment on NPS museum collections must agree to follow the principles and practices specified in the AIC Code of Ethics and Guidelines for Practice (American Institute for Conservation of Historic and Artistic Works, 1994). Refer to Appendix D for a copy of the Code of Ethics. Include this requirement in all contracts.

1. *What is treatment?*

Treatment is any action taken to prolong the existence of objects. National Park Service policy defines treatment as the following:

- preservation
- stabilization
- restoration
- reproduction

At the most basic level, preservation activities might include dusting furniture to prevent grime from becoming embedded in an important historic finish. A high level of treatment, such as restoration, might consist of cleaning a painting, filling areas of loss, and coloring the fill with new pigments to simulate the original intent of the painter.

2. *What is preservation?*

The emphasis of NPS policy is on *preservation*. NPS *Management Policies*, Section 5.3.5.5.1 states that “an item in a museum collection will be preserved in its present condition through ongoing preventive care if:

- that condition is satisfactory for exhibit or research; or
- another treatment is warranted, but it cannot be accomplished until some future time.”

Many of the chapters and appendices of the *Museum Handbook*, Part I, contain information on collection preservation. In particular, see Chapter 3: Preservation: Getting Started.

3. *What is conservation treatment?*

Conservation treatment is the deliberate alteration of the chemical and/or physical aspects of objects aimed primarily at prolonging their existence. The NPS recognizes two levels of conservation treatment:

- stabilization
- restoration

Stabilization is the first level of conservation treatment. NPS *Management Policies*, Section 5.3.5.5.1, states that “an item will be stabilized if:

- preventive measures are insufficient to reduce deterioration to a tolerable level; or
- the item is so fragile that it will be endangered under any circumstances.”

One objective of any treatment is minimal intervention to reduce the possibility of compromising the item’s integrity. Often, efforts to repair, stabilize, and restore objects have been detrimental to the long-term preservation of objects. Earlier techniques may have altered or destroyed important features of objects. In some cases, no treatment might have been a better choice. In part, this is why the preventive conservation approach has developed over the last few decades.

4. *What is stabilization?*

Stabilization or *minimal intervention* is a treatment strategy of doing the least possible to the object. The goal is to limit the possibility that conservation treatment will compromise the object's significance or result in more rapid deterioration in the future.

Information can be destroyed with any active treatment, even if done with preservation as the goal. New analytical techniques are always being developed. Later generations often re-evaluate objects and have different ideas about what makes them significant. You should understand that, even with the best of intentions, interventive treatment usually makes a permanent change to the object. Even simple cleaning is a permanent change.

5. *What are restorations?*

Restorations are treatment procedures intended to return objects to a known or assumed former state, often through the addition of non-original material. Policy on restoration is very specific (see *NPS Management Policies*, Section 5.3.5.5.2). An item may be restored to an earlier appearance if:

- restoration is required for exhibit or research purposes;
- sufficient data about that item's earlier appearance exist to enable its accurate restoration; and
- restoration will not modify that item's known original character.

Additionally:

- restoration will be accomplished using the techniques and materials that least modify the item
- restoration materials should be removable at a later time with minimal adverse effect
- restored areas should be distinguishable from original material, and documented
- restoration will take into account the possible importance of preserving signs of wear, damage, former maintenance, and other historical and scientific evidence

6. *Why use reproductions?*

The use of reproductions is a preservation strategy to make objects available for interpretive and educational presentations when the originals are too fragile, or would be subject to undue deterioration or loss. (See also *Museum Handbook*, Part III, Chapter 4: Two-Dimensional Reproductions, and Chapter 5: Three-Dimensional Reproductions.)

7. *Why should treatments be reversible?*

No treatment is completely reversible. For example, you can't "un-wash" a textile. However, conservators must use, wherever possible, materials that are removable without damage to the original material of the object. The principle of reversibility is important because objects may need to be treated again.

8. *What NPS guidance is available to help me make decisions about conservation treatment?* Review Chapter 3: Preservation: Getting Started, for information on the roles of the curator/collections manager and the conservator and for information on the Collection Condition Survey (CCS). Review the appendices in this handbook for specific information on preservation of different types of materials and collections. In addition, *Management Policies*, Chapter 5: Cultural Resource Management, discusses NPS policy for conservation treatment of museum objects.

9. *When do I need a conservator?* All interventive treatments (stabilization and restoration) **must** be undertaken by a professional conservator. A conservator is trained and skilled in the theoretical and practical aspects of preventive conservation and conservation treatment. Most conservators specialize in the treatment of specific groups of objects (for example, archeological objects, books, ethnographic objects, natural science specimens, fine and decorative art objects, photographic materials, paintings, paper, sculpture, textiles, or wooden artifacts). There is some overlap among these groups, so one conservator may work on a range of these materials. For more information on the roles that collection management specialists, curators and conservators play in the preservation of museum objects, see Chapter 3: Preservation: Getting Started.

B. Factors to Consider Before Conservation Treatment

1. *How will I know what conservation treatment is appropriate?* The treatment choices for objects and collections will vary, based on why they were collected. Share your reasons for keeping an object or collection with the conservator. You may keep objects and collections for a variety of reasons.

Appropriate treatment is developed through discussion between conservator and curator. Consider all technical, historic, scientific, cultural, religious, and aesthetic aspects of an object. Explain why you think conservation treatment is necessary. Talk about the planned use of the object. Explain where the object will be exhibited or stored. Discuss the wishes of affiliated ethnic groups. By developing a shared understanding of the object and its problems, a treatment that takes into account these many different aspects will be developed. Don't approve a treatment simply to make an object look "good" according to your standards.

Reasons for minimal intervention:

- Collections may document the history of a technology. Objects preserve various kinds of information that indicate how they were made and used. These include:
 - design features
 - composition
 - source and processing of raw materials
 - fabrication and manufacturing techniques
 - accretions

- signs of wear
- repair or alterations

In discussions with the conservator, pass on information you may have about paint, markings, residues of associated materials, grime, metallurgical features, and other easily lost remnants.

- Collections may have scientific research value.

Most archeological, natural history, and archival collections are preserved as evidence or as information for research and study purposes. Some ethnographic and historical collections may be preserved for this reason as well. For these types of collections, appropriate treatment always requires minimal intervention.

- Objects may be culturally or legally significant.

Many park collections contain objects that have special significance to Native Americans or other cultural groups. Identify the culturally relevant group, if any, for all items in your collections. Consult with a qualified ethnographer to help identify relevant groups, materials, community consultants, and questions that should be raised when considering the treatment. Consultation with representatives of Native American or other groups should be sought to help identify significant objects and determine appropriate treatments. If there are questions about the acceptability of a treatment, wait until more is known.

Collections may also have associations with eminent individuals, groups, events, or sites. You should be sure that treatment does not destroy evidence of that association. For example, you wouldn't remove bloodstains on the coat Abraham Lincoln was wearing when he was assassinated.

There may be legal issues to consider as well. For example, land records may be used as legal proof, and treatment may affect their legitimacy.

Reasons for restoration:

- Objects may have a special function.

Parks collect some objects because of a special function they perform. For example, a certain musical instrument may produce a quality of sound worth preserving. To preserve the functional capability of an object, worn out or defective parts may require replacement. When considering a treatment for this kind of object, ask "Is preservation of function more important than preservation of the original material?"

- Appearance of the object may be important.

Restoration is often carried out to improve appearance—especially when an object is prepared for exhibit. Often you will have to make a decision about whether to leave signs of wear and tear, or to restore an object closer to original appearance. Ask these questions:

- Why do I want to restore the former appearance? For example, when deciding whether to replace a missing leg on a chair to be displayed in a historic house, consider that the inhabitants probably did not use a broken chair.
- When would restoration go too far and be fraudulent or unethical? For example, overpainting original material so that some of the original is hidden would be fraudulent.

2. *What guidelines should I follow when considering restoration?*

The line between stabilization and restoration is not exact. For example, a torn document can be stabilized by encapsulation between two sheets of Mylar®. This might not be an acceptable treatment for exhibition. A conservator can mend the tear. This is stabilization, but the treatment also *restores* the original shape or format of the document.

Follow these guidelines when reviewing a treatment proposal that suggests restoration:

- Restoration should be based on known facts, not conjecture.
- Restoration should not modify the original character (shape, size, information, visual aesthetic) of an object or item.
- Restoration should be minimally interventive. Agree on techniques and materials that cause the least modification to an object and that can be removed most completely, if necessary, with minimum effect.
- Restored areas should be distinguishable from original material upon close visual inspection, but need not be conspicuous. Ensure that all restored areas are fully documented in the treatment report.
- Restoration should take into account the significance of wear, damage, former maintenance, or other historic or scientific evidence.

3. *What is the difference between conservation treatment and routine maintenance?*

Routine maintenance keeps an object in working order, while conservation treatment stabilizes the condition of an object within a museum context. Many of the objects in NPS collections were used in the everyday world. Utilitarian objects required repair and maintenance in order to function properly. However, once objects are removed from regular use, the same maintenance procedures can cause deterioration. For example, applying "leather dressings" to horse tack is important to keep pieces flexible and clean while they are being used. After accessioning, however, leather dressings will cause build up on the leather and accelerate deterioration.

In contrast to the use objects receive outside a museum, museum objects are preserved so they can be studied or exhibited. The goals for preservation are different, so the procedures and materials for care may be different. Work with a conservator to ensure that routine care and maintenance procedures are appropriate for the long-term preservation of the object. For examples see:

- *Conserve O Gram 9/1, Leather Dressing: To Dress or Not to Dress*
- *Conserve O Gram 10/3, Preparing Historic Motorized Vehicles for Storage and Exhibit*

C. Documentation of Conservation Treatment

All conservation treatment must be documented in writing. Many treatment records will also include graphic documentation (for example, photographs, drawings, analytical results, spectra, and digital images). NPS conservation treatment policy follows the guidelines for documentation in the *Code of Ethics and Guidelines for Practice of the American Institute for Conservation of Historic and Artistic Works* (AIC) (see Figure 8.1).

File all treatment documentation in the appropriate accession folder or catalog folder. You must keep a paper copy of all electronic records.

1. *Why is conservation documentation important?*

Documentation is important for these reasons:

- Conservation documentation is a written and graphic report of the work that is done. It provides the park staff with information on the condition of the object, such as how its original state has been altered, what is original material, and what is old restoration.
- It serves as a permanent record of the treatment procedures performed and the materials and methods used.
- It spells out the understanding reached between the curatorial staff and the conservator on the treatment, including the extent and type of any stabilization or restoration treatment.
- It makes possible the assessment of the success or failure of treatment methods and materials over a long period of time and provides information that will help future conservators to assess an object's condition and devise further treatment.
- It may last longer than the object itself and become the only record.

2. *What is the ANCS+ Conservation Associated Module?*

The Conservation Associated Module is a feature of ANCS+ that allows parks to incorporate conservation documentation directly into park-automated records. The module is a system that transfers copies of basic catalog information to the conservator and then easily transfers conservation documentation back into the park records.

The conservator must use templates created for Access, Excel, or ASCII formats to record survey, treatment, and analytical information. The template is required to make documentation compatible with the ANCS+ database. Complete instructions for using the Conservation Associated Module can be found in the ANCS+ User Manual, Appendix J.

Contracts with NPS and non-NPS conservators must include the requirement for using ANCS+ compatible reporting formats to ensure that data can be uploaded (see [ANCS+ User Manual, Appendix J](#)).

3. *What types of conservation projects can be recorded in the Conservation Associated Module?*

There are four types of conservation projects recorded in the Conservation Associated Module:

- Condition Survey
- Treatment Proposal
- Treatment Report
- Analysis

Parks use the Conservation Associated Module to:

- transfer basic catalog data from the park to the conservator to speed data entry and allow for improved conservation documentation
- incorporate documentation produced by conservators directly into park automated records (You don't have to enter data from paper records generated by the conservator.)
- ensure that you get documentation of critical information (The data fields guide the conservator to provide specific kinds of information in the report.)
- ensure documentation does not get lost over time (Paper reports are harder to track and keep associated with the objects over time. Data in the computer remains associated with the objects on a long-term basis. In addition, the National Catalog keeps backups from your yearly submission.)

Conservators use the Conservation Associated Module data templates to:

- facilitate incorporation of information they generate into park automated records as well as conservation lab databases
- ensure that their documentation is readily available to future curators, conservators, and researchers
- integrate conservation information in the primary database used to make management decisions about collections
- assist in managing conservation for the object, for example, the ANCS+ program facilitates:
 - simple estimation of hours for treatment projects on multiple objects
 - documentation of the amount of work accomplished in a year
 - word searches on treatment materials or types of objects treated
 - searches to find similar objects from past work
 - searches to find all work done for a park over numerous projects

Guidance for using the Conservation Associated Module is included in the *ANCS+ User Manual*, Appendix J: The Conservation Associated Module.

4. *What kinds of documentation should I require from the conservator?*

In addition to information recorded in the Conservation Module, get a copy of all documentation recorded by the conservator:

- **Written reports:** The conservation profession requires documentation of examination, scientific investigation, and treatment by creating permanent records and reports. The written reports often contain information on research into materials and technology that are beyond the scope of the Conservation Associated Module. They are prepared either in a narrative style or checklist format. See Figures 8.2–8.4 for sample reports. For multiple object treatments, summary reports may be included as well.
- **Photographs:** Most treatment documentation will include detailed photography. A complete series will include photos taken before, during, and after treatment. Photographic documentation can be archivally processed black-and-white prints or color slides. Digital images **may not** be substituted for black-and-white prints or color slides. Specialized photographic techniques are often used. These include use of:
 - ultraviolet light—some restorations fluoresce and become more visible
 - infrared light—may reveal details under layers of grime and old coatings; may improve the legibility of difficult-to-read inscriptions
 - raking light—shows surface irregularities by illuminating the surface from an acute angle
 - reflected light—shows variation in gloss or texture by recording the reflection of a light source
 - x-ray radiography—may reveal internal features
 - transmitted light—may show missing areas in translucent objects
 - photomicrography—shows details too small to see with the naked eye
- **Drawings and illustrations:** These media are used to note changes or significant features that are hard to illustrate with photographs (for example, repairs, selvage edges, changes in sewing threads in textiles).
- **Analytical records:** If analysis is undertaken to identify materials or techniques, additional types of information may be generated, such as analytical reports and interpretation, spectra, and graphs. Parks must keep complete sets of the data as part of the record of conservation work.

	MINIMUM DOCUMENTATION REQUIREMENTS	RECOMMENDED DOCUMENTATION REQUIREMENTS
All Documentation	Include: <ul style="list-style-type: none"> • purpose • documentation by (name) • date • object name • object ID/unique information • catalog number • registration number • measurements • marks/labels/features 	Include associated records such as: <ul style="list-style-type: none"> • previous treatment • excavation reports • curatorial reports • scientific reports
Examination Reports	Include: <ul style="list-style-type: none"> • observations • present condition • notation of accessory materials or associated elements • past treatment evidence • methods of examination and testing 	Include: <ul style="list-style-type: none"> • drawings/photos to illustrate condition and relevant details (include control numbers) • size scale • gray/color scale (photos) • light direction (photos) • object ID
Treatment Proposals:	Include: <ul style="list-style-type: none"> • treatment plan • materials to be used • time estimate • cost estimate (when appropriate) 	Include: <ul style="list-style-type: none"> • objectives and limitations of treatment, benefits, and risks • general description of properties of materials to be used • statement that minor variations in treatment may be required as treatment progresses
Treatment Reports:	Include: <ul style="list-style-type: none"> • conservator name • report date/treatment date • procedures used that deviate from proposal • added materials that remain on object • materials used on object that do not remain • removed materials • materials obscured by treatment • new information about object revealed in treatment (including features hidden by assembly) • changes in artifact as a result of treatment including its state after treatment • names of assisting conservators, consultants, and contractors • dated graphic documentation 	Include: <ul style="list-style-type: none"> • procedures and materials considered, but not chosen • recommendations for subsequent care and maintenance • treatment time • treatment cost (when needed)

Figure 8.1. Information Required in Conservation Treatment Documentation
(Taken from AIC Guidelines and Standards for Practice)

5. *What are typical documentation steps when an object is treated?*

Most object conservation treatment documentation will include the following steps:

- 1) Park staff provide the conservator with historical information relevant to the treatment or any record of condition or treatment.
- 2) The Conservator prepares an *examination report* (see Fig. 8.2). This examination report is often part of a Collection Condition Survey (CCS). (See Chapter 3: Preservation: Getting Started.) This may also be included as part of the treatment proposal. This report should include:
 - a description of the materials, structure, and construction of the object
 - an analysis of materials, if appropriate
 - a description of the condition of the object and evidence of past treatment, with reference to any previous documentation
 - any deductions, interpretations, or comments
- 3) The conservator prepares a *treatment proposal*. See Figure 8.3 for a sample treatment proposal. In this document the conservator outlines the proposed treatment and includes alternatives, if any. The proposal usually will not list all the technical details that are listed in the treatment report. The treatment proposal should address all the problems identified in the examination report. It should include time/expense estimates. The park curator reviews the treatment proposal and approves it with the concurrence of the park superintendent.

The conservator should discuss any significant departures from the proposal as the treatment is carried out and receive approval for those changes from the curator (and Contracting Officer's Technical Representative [COTR] if applicable).

- 4) The conservator prepares a *treatment report*. See Figure 8.4 for a sample treatment report. In this document the conservator details the steps of the treatment that were undertaken. The conservator will discuss the treatment results and often make recommendations about future care, exhibition, or storage requirements. If there are any variations from the original treatment proposal, the park will have approved the changes in writing. The conservator will also discuss treatment changes and their rationale in the final report.

6. *What kinds of documentation should park staff generate on its own treatment activities?*

Record two types of activities:

- You must keep a record of housekeeping tasks done by staff. These tasks include:
 - cleaning (method and frequency)
 - dusting
 - waxing

- maintaining proper fluid levels in wet specimens

Record this information in the ANCS+ Maintenance Associated Module. Instructions for using the module can be found in the *ANCS+ User Manual*, Chapter 4: Associated Modules. Provide this information to the conservator as part of the historical information about the object.

For more information about developing a housekeeping plan, including the documentation, see Chapter 13: Museum Housekeeping.

- You should also record any observed changes in the condition of the object. Record these in the Catalog Record in ANCS+ in the condition and condition description fields.

D. Obtaining the Services of a Conservator

When you need a conservator:

- Take time to locate an experienced, well-qualified conservator. This point is critical to the quality of treatment an object will receive.
- Prepare a scope of work (SOW) for the project. Regional/SO curators and NPS conservation laboratories can provide you with sample SOWs.
- Discuss the process with the conservator and others involved in the project to be sure each person (park manager, park curatorial staff, regional curator, and conservator) understands the others' roles.
- Be sure contract conservators understand the NPS conservation treatment policy to preserve what remains of an object in as stable a condition as possible. Provide them with NPS policy and procedural guidelines, such as pertinent sections of the *Museum Handbook* and *ANCS+ User Manual*.

1. *How do I find a conservator?*

Work with your regional/SO curator to find a NPS conservator or a conservation contractor with the appropriate knowledge and experience. The regional/SO curator can help locate possible conservators to perform the work and help you find funds for the project. They will also help set priorities and determine a time frame for the project, as well as help prepare procurement documents. Discuss the type of project (for example, treatment of a single object, treatment of a group of objects, identification of methods and materials used to create an object) with the regional/SO curator and determine:

- the nature of the object or collection (type of material and condition)
- the present use of the object or collection
- the planned use of the object or collection (for example, for research, in an exhibit, as a working piece of equipment in demonstrations)

2. *How do I decide if a suggested conservator and treatment are suitable?*

First, ensure that the treatment proposal is in response to and addresses an existing documented condition. You also can judge this by evaluating treatment recommendations against the AIC Code of Ethics. In particular, be aware of the following points in the Code:

- *The conservation professional shall practice within the limits of personal competence and education as well as within the limits of the available facilities.* Ask the conservator these questions:
 - What is your training for this sort of treatment?
 - Have you ever treated objects like this before?
 - Do you have the proper equipment to carry out this treatment?
 - What kind of security and fire protection does your facility have?
 - Can you give me references from previous clients?
- *The conservation professional must strive to select methods and materials that, to the best of current knowledge, do not adversely affect objects or their future examination, scientific investigation, treatment or function.* Ask the conservator these questions:
 - How will this treatment affect future analysis?
 - If you do this treatment, can the object be re-treated in the future? No treatment is completely reversible, but it is possible to use materials and techniques that allow for re-treatment. For example, you may not be able to remove a consolidant added to give structural strength. However, the choice of consolidant should not rule out the use of a later, alternative treatment, if the original treatment fails.
- *The conservation professional shall document examination, scientific investigation, and treatment by creating permanent records and reports.* Ask the conservator these questions:
 - What kind of photo-documentation will you do?
 - How will you ensure photographs are archivally processed?
- *The conservation professional shall recognize a responsibility for preventive conservation by endeavoring to limit damage or deterioration to objects, providing guidelines for continuing use and care and recommending appropriate environmental conditions for storage and exhibitions, and encouraging proper procedures for handling, packing, and transport.* Ask these questions:
 - How would you recommend I handle and store this object in the future?

- Do you have any recommendations for the future exhibit of this object?
- Does this object pose health and safety risks to staff or risks to nearby materials?

3. *What do I need to know about contracting for conservation treatment services?*

Work directly with your park or regional procurement officer to ensure that you prepare the proper documents for all conservation services. The procurement officer should be able to provide you with the information you need to decide on the appropriate type of procurement.

Consider taking a basic procurement course to get a background in the tasks that are required. The Federal Acquisitions Institute (FAI) sponsors on-line training in acquisition and contracts management at <<http://www.faionline.com>>.

Ask a NPS conservator to serve as the Contracting Officer's Technical Representative (COTR). The COTR is a federal employee who provides advice on the technical aspects of the work being contracted. A NPS conservator has the technical knowledge to evaluate a treatment proposal and can assist you and the contracting officer with the resolution of technical problems and help approve necessary changes that may come up during the treatment process. **Note:** Be sure the COTR has expertise in the type of material that is being treated.

A regional/SO curator, knowledgeable park curator, or NPS conservator can serve as the COTR for collection condition surveys and general preservation services provided by a conservator.

Ensure that the contract specifies “work for hire” and that the contractor transfers copyright of all documentation, including photographs (see Museum Handbook, Part III, Chapter 2, Sec. C.7 and Chapter 3, Fig. 3.4).

4. *What happens after the conservator is selected?*

Once you have selected a conservator, schedule the project. If objects will be shipped to the conservation lab, schedule the shipment dates with the conservator. Discuss packing and shipping methods to ensure the objects are not damaged in transit.

Review all examination reports and/or treatment proposals. Discuss your questions with the conservator. The person with delegated responsibility (usually the curator) must approve and sign a treatment proposal before work can begin. Get advice from the regional/SO curator or NPS conservators to ensure that the proposal describes an appropriate treatment. File a copy of the signed treatment proposal in the Catalog Folder or Accession File.

5. *When I am evaluating a treatment proposal, what should I consider?*

Before you allow conservators to carry out a treatment on an object, you must approve their written treatment proposal. When evaluating a conservation treatment proposal, consider the following factors:

- The park superintendent has ultimate responsibility for each object. Don't simply accept a recommendation, but question and evaluate its quality. Ask the regional/SO curator or a NPS conservator with expertise

in the type of object to be treated to review treatment proposals before work begins. During treatment, the curator (and COTR, if applicable) must review and approve any significant deviations from the proposal.

- Every active treatment carries inherent risk. No conservator can or will guarantee the final outcome.
- Conservators must convince you that their recommendations are governed by total respect for the physical, historic, and aesthetic integrity of an object by the explanations that they include in the treatment proposal.

6. *What are my responsibilities once the treatment proposal is approved?* Monitor the work by visiting the conservation lab or discussing progress with the conservator. After treatment is completed, the conservator will return the objects to the park. Before approving payment, ensure that all conditions of the contract or SOW were completed satisfactorily. Review electronic data provided by the conservator and incorporate accepted data into the ANCS+ Conservation Associated Module. Consider having another conservator review the work. File all documentation (reports, photographs, drawings, etc.) in the Catalog Folder or Accession File.
7. *Where can I find information on how to treat objects in an emergency?* Refer to Chapter 10: Emergency Planning, for information on planning for and recovering from an emergency. This chapter also gives you information on basic actions you can use to minimize damage. In particular, review Figure 10.13, First 48 Hours Emergency Response Checklist.

Use the Emergency Response and Salvage Wheel from Heritage Preservation (mailed to all parks in 1997) <<http://www.heritagepreservation.org/>>. This tool gives you basic steps to take after a disaster strikes.

Contact a conservator as soon as possible for advice on how to recover from the emergency.

E. Glossary

Accretion – accumulated materials not original to the object that are attached to the surface of an object. For example, calcium deposits may accumulate on buried (archeological) ceramics.

Conservation – the deliberate alteration of the chemical and/or physical aspects of objects, aimed primarily at prolonging their existence. Treatment may consist of stabilization and/or restoration.

Inherent vice – the nature of the material or the results of manufacturing techniques that cause an object to deteriorate more rapidly than normal, or that make stabilization nearly impossible. For example, 19th century silk fabrics were sometimes treated with metallic compounds that cannot be removed from the fabric, but cause the fabric to split and powder.

Intervention – taking direct, hands-on action to stabilize the condition of an object

Minimal intervention – using only those treatments necessary to stabilize the condition of an object

Preservation – all actions taken to prolong the life of an object

Preventive care – synonym for preventive conservation

Preventive conservation – non-interventive actions that can be taken to prevent damage to and minimize deterioration of museum objects

Reproduction – a copy of an item for exhibit, interpretive, educational, sale, research or other purpose, made when use of the original would be inappropriate or would cause undue deterioration or loss

Restoration – an attempt to bring museum objects closer to their original or other previous appearance by removing additions not considered historically important, replacing missing parts, renewing finishes, and/or concealing damage

Reversibility – the principle of using materials that can be removed, in so far as possible, should re-treatment of an object become necessary

Spectrum – a graphic or photographic representation of the distribution of energy emitted by a radiant source. For example, spectra might be produced by analytical techniques used to identify the type of varnish on a piece of furniture.

Stabilization – treatments applied to museum objects to increase their stability or durability when preventive conservation actions are insufficient to reduce the rate of deterioration, or when deterioration has rendered them so fragile as to be in danger under any circumstances

Treatment – methods or techniques that are usually interventive in varying degrees to preserve the condition or appearance of a museum object

Work for hire – work produced by employees as part of their responsibilities, or rights to work transferred to the employer through contractual agreement

F. Selected Bibliography

American Institute for Conservation of Historic and Artistic Works. *Code of Ethics and Guidelines for Practice of the American Institute for Conservation of Historic and Artistic Works*. Washington, D.C.: American Institute for Conservation of Historic and Artistic Works (AIC), 1994.

_____. *Commentaries to the Guidelines for Practice of the American Institute for Conservation of Historic and Artistic Works*. Washington, D.C.: American Institute for Conservation of Historic and Artistic Works (AIC), 1994.

_____. *Guidelines for Selecting a Conservator*. Washington, D.C.: American Institute for Conservation of Historic and Artistic Works (AIC), 1991.

Ball, Stephen. *Larger and Working Objects: A Guide to Their Preservation and Care*. London: Museums and Galleries Commission, 1997.

Child, Robert E. "Ethics and Museum Conservation." In *Museum Ethics*. New York: Routledge, 1997.

National Park Service. *Management Policies 2001*. Washington, D.C.: National Park Service, 2000.

Price, Nicholas Standley, M. Kirby Talley Jr., and Alessandra Melucco Vaccaro. *Historical and Philosophical Issues in the Conservation of Cultural Heritage*. Los Angeles: The Getty Conservation Institute, 1996.

Sturman, Shelley G. "Obtaining Professional Conservation Services." In *Caring for Your Collections*. New York: Harry N. Abrams, 1992.

Ward, Phillip. "The Training of Conservators." In *The Nature of Conservation: A Race Against Time*, Santa Monica, Calif.: The J. Paul Getty Institute, 1986.

Williams, Stephen L. "Preventive Conservation: The Evolution of a Museum Ethic." In *Museum Ethics*. New York: Routledge, 1997.

G. Internet Resources

American Institute for Conservation of Historic and Artistic Works: <<http://aic.stanford.edu>>.

Conservation OnLine (CoOL): <<http://palimpsest.stanford.edu/>>.

Object Examination Report

Owner:	National Park Service	Laboratory Supervisor:	
Catalog No:	WASO1	Proposed by:	Lesley Jones
Object:	Frock coat	Date Proposed:	January 5, 2001
Lab Tracking No:	11788.70	Estimated Hours:	75 hours

DESCRIPTION:

The object is a single breasted Civil War frock coat of navy blue doeskin (fulled wool) with a standing collar and long cuffed sleeves. The coat has a nine-button center front closure. It is fully lined—the body and skirt with green wool and the sleeves with natural colored twill weave cotton. There is a belt tab on the proper right (PR) side at the waist and an inner breast pocket on the proper left (PL) side of the coat. The 2.4 cm (7/8 inch) diameter brass buttons depict an eagle with a shield. The eagle holds an olive branch in his PL talons and a shaft of arrows in his PR talons; he faces to the right. Two of the same buttons adorn the back vent of the skirt at the waist; each sleeve cuff contains three smaller diameter buttons—1.5 cm (1/2 inch)—with the same eagle and shield design. The buttons have a maker's mark on the back "HORSTMANN & CO / NY & PHI." Shoulder boards of navy blue wool with sheet brass stamped to resemble gold bullion embellish both shoulders.

Dimensions:

Length: 98.9 cm (39 inches) (measured at the center back from the top of the collar to the bottom edge)
Width: 53.4 cm (21 inches) (measured at the widest point across the shoulders)

Structure or Construction:

This coat is a well-made, hand tailored garment constructed of high quality piece goods. The doeskin is fine. This coat does not have bound buttonholes. The collar is lined in black velvet.

The back is constructed in four pieces with a center back seam and two princess seams. Each front section is a single piece with a dart extending up 14.1 cm (5-1/2 inches) from the waist seam. The sleeves are constructed of two pieces with an added cuff that measures 6.5 cm (2-1/2 inches) in width. The skirt is constructed of two main pieces with small additional pieces used to form the vent in the center back. The entire coat is lined—the body and skirt with a green wool and the sleeves with natural colored twill weave cotton. The inside front panels are quilted; the quilting extends under the arms to the princess seams.

Figure 8.2. Sample Narrative Examination Report

CONDITION:

The coat is in excellent structural and aesthetic condition.

The shoulder guards are very heavy and may not be entirely original. The sheet brass appears to be attached to navy wool, which in turn has been stitched to what may be a modern, black fabric. This final layer is what has been stitched to the shoulders of the coat.

There are several small holes, a result of insect damage, scattered across the surface of the coat; they do not compromise the coat's structural integrity. There is a hole the size of a nickel in the center back along the bottom edge and slightly smaller holes on both sleeves at the elbows. There is a 1.3 cm (½ inch) tear at the PL sleeve seam in the back. The center front edge is unstitched along much of its length on both sides.

The lining is in excellent condition. There is one hole in the lining in the area of the inner breast pocket. The collar lining has come unstitched at the center back.

PREVIOUS REPAIRS, TREATMENT, MOUNTING:

Some buttons may have been re sewn. Aside from the difference in thread used, it is possible to tell the difference between original and re sewn buttons because the original buttons were sewn on before the facing was attached. As a result, the stitching does not extend through all layers and is not seen on the inside. In contrast, the stitching on re sewn buttons extends through all layers and can be seen on the inner face of the coat. Components of the shoulder boards may have been replaced.

PHOTOGRAPHIC DOCUMENTATION:

None

Figure 8.2. Sample Narrative Examination Report (continued)

Object Treatment Proposal

Owner:	National Park Service	Laboratory Supervisor:	
		Proposed by:	Lesley Jones
Catalog No:	WASO1	Date Proposed:	January 31, 2001
Object:	Frock coat	Estimated Hours:	75 hours
Lab Tracking No:	11788.70	Cost of Treatment:	

DESCRIPTION AND CONDITION:

See Object Examination Report dated January 5, 2001.

PROPOSED TREATMENT:

1. Vacuum clean coat using reduced suction.
2. Visually reintegrate areas of loss using compatible weight and color fabric to back holes.
3. Clean buttons and apply protective coating of microcrystalline wax.
4. Restitch seams requiring stitching; reinforce with Stabiltex polyester multifilament fabric as needed.
5. Examine shoulder guards. Because of their weight, explore mounting options besides stitching them to shoulder of coat.
6. Prepare custom-built mannequin on which to display coat when on exhibit.

DOCUMENTATION:

The artifact will be photographed with Ektachrome 160 Tungsten color slide film before and after treatment. Minute fiber samples will be taken and mounted on microscope slides for visual analysis.

Figure 8.3. Sample Treatment Proposal

RECOMMENDATIONS FOR SUBSEQUENT CARE:

DISPLAY REQUIREMENTS:

- Light levels should not exceed 5 lux (5 footcandles) using a Visitor Activated lighting system.
- The coat should be inspected annually for signs of pest infestation.
- The coat should be micro vacuumed while on exhibit as required. Vacuuming frequency should be determined by inspecting the textile and noting the accumulation of dust inside the exhibit case.
- The coat should be rotated off display in 2 to 3 years and allowed to remain in storage for at least 5 years before being exhibited again.

POST EXHIBITION CARE:

The coat should remain in storage, in a dark, clean, stable environment for at least 5 years after rotation. See *NPS Museum Handbook*, Part I, pages K:19-29 for preventive conservation, handling and storage procedures.

If you agree with this proposal, please sign it and return it to the conservator. Your approval of this request must be received before work can proceed. The conservator will be happy to discuss this treatment proposal with you and answer any questions. If significant changes to this proposal are anticipated once treatment has begun, the conservator will consult with you.

Prepared by: _____ Date: _____
Title: Conservator

Approved by: _____ Date: _____
Title: Curator

Concurred by: _____ Date: _____
Title: Superintendent

Figure 8.3. Sample Treatment Proposal (continued)

Object Treatment Report

Owner:	National Park Service	Laboratory Supervisor:	
Catalog No:	WASO1	Treated by:	Lesley Jones
Object:	Frock coat	Date Completed:	May 10, 2001
Lab Tracking No:	11788.70	Total Lab Hours:	75 hours

DESCRIPTION:

See Object Examination Report dated January 5, 2001.

CONDITION AND TREATMENT PROPOSAL:

See Object Treatment Proposal dated January 31, 2001.

TREATMENT:

Several small holes scattered across the surface of the coat, a result of insect damage, as well as the insect or rodent damage evident along the bottom edge of the coat in the center front, were repaired using patches of a compatible blue wool fabric placed behind the holes and secured with stitching using a thread pulled from Stabiltex, a polyester multifilament fabric. The buttons were cleaned and degreased with Stoddard solvent and a protective coating of microcrystalline wax was applied using cotton swabs. Stitching securing seams of the coat and lining that had failed in numerous areas was replaced using a thread pulled from Stabiltex. A custom mannequin was built on which to display the coat when on exhibit. Once the coat was fit on the mannequin, it was vacuumed using reduced suction.

The shoulder bars were removed from the coat and gently reshaped to better fit the shoulders of the coat. To prevent further damage to the coat, a Velcro hook was sewn to a support fabric and the fabric was sewn to shoulders of the coat with a black cotton thread, 3 S plied Z. A strip of Velcro fabric was sewn to the underside of the shoulder bars. The Velcro hook attaches to Velcro fabric securing the shoulder bars in place.

PHOTOGRAPHS:

Before:	Yes
During:	No
After:	Yes
Type Film:	Ektachrome 160T

SUPPORTING DOCUMENTATION:

Fiber Analysis: No

Figure 8.4. Sample Treatment Report

RECOMMENDATIONS FOR SUBSEQUENT CARE:

DISPLAY REQUIREMENTS:

- Light levels should not exceed 30 lux (3 footcandles) using a Visitor Activated lighting system.
- The coat should be inspected annually for signs of pest infestation.
- The coat should be micro vacuumed while on exhibit as required. Vacuuming frequency should be determined by inspecting the textile and noting the accumulation of dust inside the exhibit case.
- The coat should be rotated off display in 2 to 3 years and allowed to remain in storage for at least 5 years before being exhibited again.

POST EXHIBITION CARE:

The coat should remain in storage, in a dark, clean, stable environment for at least 5 years after rotation. See NPS *Museum Handbook*, Part I, pages K:19-29 for preventive conservation, handling and storage procedures.

Notes:

Fuller wool was a British specialty. After the cloth was woven, removed from the loom, and scoured to remove the oils used in the spinning process, fulling occurred to both felt the cloth and shrink it. Fulling was done in a fulling mill using wooden hammers or stocks to raise the nap. The cloth was first scoured with the slow motion of hammers, "leisurely without such violence as heats it much;"¹ fulling was then done with "quick heavy strokes which heat the cloth and shrink the fiber"² using an *aena*, a flat wooden implement set with spikes. In some cases the woven cloth was burlled before being fullled but after being scoured. Fuller's earth in soft water was used as a detergent in the scouring process; if Fuller's earth was not available, sig (stale urine) or swine's dung was employed instead. The scouring agent needed to be alkaline; sig provided a natural source of ammonia.

The main problem in fulling was ensuring that the textile shrank evenly. "Fine medley broadcloth made in the early eighteenth century shrank less than half its width and one-third its length." Shrinkage was proportional to the texture of the cloth and the length of the fulling process; the thinner the cloth, the less the shrinkage. Well-woven Wiltshire medleys of the eighteenth century could be finished in nine hours; the process was lengthened considerably for badly woven cloth. The degree of fulling varied by location —Gloucestershire cloth tended to be more heavily fullled.

Cloth was easily damaged during the fulling process. After emerging from the fulling mill, the cloth was hung on tenters to dry; the tenters served to stretch the wet fabric. The fulling process sometimes left the sides of the cloth longer than the middle section. Gloucestershire led in the mechanization of scouring; Wiltshire led in the mechanization of fulling. The first patent for a fulling machine was obtained in 1833; by the mid-19th century the fulling process was fully mechanized.

¹Jenkins, J. Geraint ed. *The Wool Textile Industry in Great Britain*. London: Routledge & Kegan Paul, 1972.

²Mann, J. de L. *The Cloth Industry in the West of England from 1640 to 1880*. Oxford: Clarendon Press, 1971.

Figure 8.4. Sample Treatment Report (continued)

CHAPTER 9: MUSEUM COLLECTIONS SECURITY AND FIRE PROTECTION

A. Overview

As hard as we try, nothing lasts forever. Still, an effective preservation program can delay the inevitable. Preventive conservation can slow the rate of loss to natural, expected causes, while a comprehensive security system can help limit losses from unexpected causes, such as fire, theft, natural disasters, and accidental damage. Security and fire protection are as important to the long-term survival of a collection as proper curation, storage, and conservation and must be an integral part of the day-to-day care of the collection.

1. *What is a comprehensive security system?*

A comprehensive security system combines policies, procedures, personnel, and hardware to protect museum collections from unexpected losses caused by crime, negligence, fire, or other catastrophic events. Four concepts are implicit in such a system:

- The park itself is a system, and security is one of its subsystems.
- Identifying objectives precisely and clearly is the most important step you can take in designing an effective system. A security system for museum collections, for example, has two principal objectives: to protect museum collections and associated records from catastrophic loss, and to protect the documentation related to objects in the collection, such as accession records, catalog records, conservation reports, and photographs.
- No single subsystem or component can achieve a security system's overall objectives. Subsystems must complement each other to make the system efficient and ultimately successful.
- Subsystems and components are interdependent within a system. Changes in one part affect the whole system and may have unexpected consequences. For example, placing an air handler in a museum collection storage area might be an efficient use of space, but it complicates access control, adds a potential source of ignition, and increases the risk of accidental damage to museum objects.

2. *How should I design an effective security system?*

There are no cookbook solutions for security problems, and no single recipe will turn out a perfect security system every time. Each park must develop its own system. Every park is unique, faces different threats, has different short-term objectives, and has different resources available. While security concepts are mostly common sense, applying them effectively requires care, consideration, and experience.

One way you might think about a comprehensive security system is to visualize a series of concentric circles that form a bull's-eye (see Figure 9.1). Simply stated, you should add more and tighter security precautions as

you get physically closer to a high value object, like the rings on the bull's-eye diagram. The more valuable the protected object, the more protection rings there should be, and the more they should focus on the object. The figure also shows the overlapping and complementary roles played by park boundaries, policies, procedures, the building shell, cases, electronic systems, and personnel.

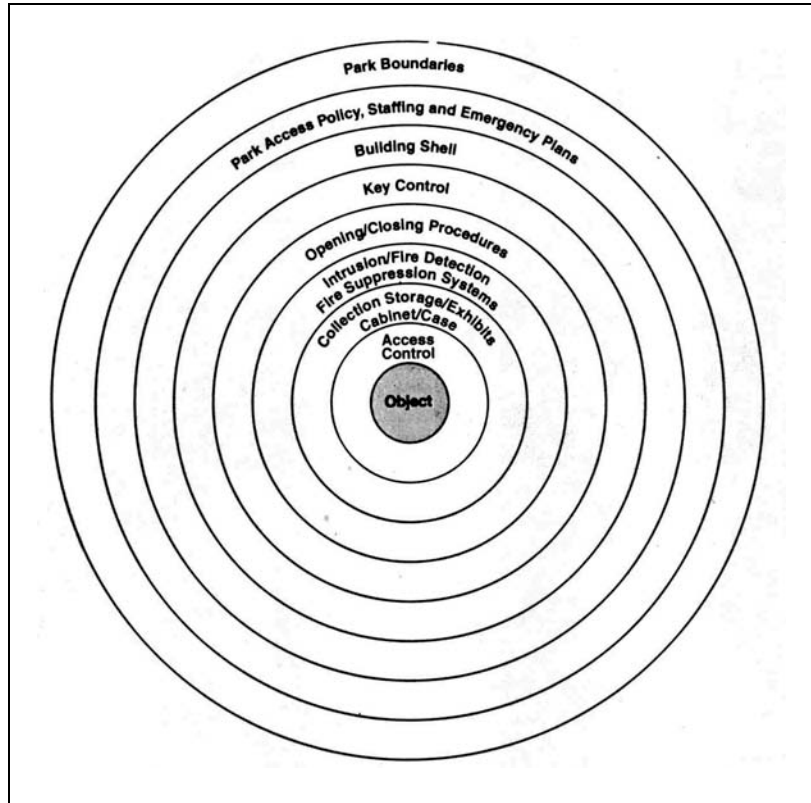

Figure 9.1. Security Bull's-Eye

3. Who is responsible for security?

Overall responsibility for protecting the park's museum collection rests with the superintendent, while museum and law enforcement staff share direct day-to-day responsibility. Nevertheless, you and all of your fellow park employees—permanent, seasonal, salaried, or volunteer—are part of the park's security system and have security responsibilities that should be reflected in the park's standard operating procedures (SOPs).

4. *What information will I find in this chapter?*

Information in this chapter will help you:

- identify threats to your collections
- assess the risk of loss
- select and implement appropriate countermeasures
- measure the effectiveness of those countermeasures

See NPS Museum Handbook, Part I, Appendix G: Protection of National Park Service Museum Collections, for NPS security and fire protection standards, glossary of terms, and sample statements of work, standard operating procedures, and agreements.

B. Legal, Regulatory and Policy Requirements

Protection of museum collections is basic to the mission of the National Park Service. The following digest of statutes and policies provides a starting point for a park's protection program. In essence, they require you to use the most effective means available to protect museum collections against fire, theft, and other threats without compromising their integrity.

1. *What laws and regulations do I need to know?*

Title 40 United States Code (USC), Public Buildings, Property, and Works Paragraph 486(c) provides statutory authority for the head of each executive agency to issue orders and directives necessary to manage the Government's property.

Code of Federal Regulations (CFR) 41 Federal Property Management Regulations Part 101, Subpart 20.5 "Physical Protection", prescribes policies and methods for physically protecting buildings and grounds operated by GSA and other Federal Executive agencies. The Department of the Interior's property management regulations are in Part 114 of CFR 41.

2. *Which parts of the Department of the Interior's Manual address protecting museum collections?*

Part 411, Chapters 1-3, sets standards and requirements for protecting museum property.

Part 444, Chapter 1, tells you how to safeguard personnel, prevent unauthorized access to Federal property and records, and safeguard against espionage, sabotage, vandalism, and theft.

3. *What sections of NPS Management Policies refer to protecting museum collections?*

Section 5.3, Stewardship concerns the protection and preservation of cultural resources. It states the National Park Service will employ the most effective concepts, techniques and equipment to protect cultural resources against theft, fire, vandalism, overuse, deterioration, environmental impacts, and other threats, without compromising the integrity of the resources. It also states that:

- Measures to protect or rescue cultural resources in the event of an emergency, disaster, or fire will be developed as part of a park's emergency operations and fire management planning processes. Designated personnel will be trained to respond to all emergencies in a manner that maximizes visitor and employee safety and the protection of resources and property.
- In the preservation of historic structures and museum and library collections, every attempt will be made to comply with national building and fire codes. When these cannot be met without significantly impairing a structure's integrity and character, the management and use of the structure will be modified to minimize potential hazards, rather than modifying the structure itself.

- When warranted by the significance of a historic structure or a museum or library collection, adequate fire detection, warning, and suppression systems will be installed. “Pre-fire plans” will be developed for historic structures and buildings housing museum or library collections, designed to identify the floor plan, utilities, hazards, and areas and objects requiring special protection. This information will be kept current and made available to local and park fire personnel.
- Park and local fire personnel will be advised of the locations and characteristics of cultural resources threatened by fire, and of any priorities for protecting them during any planned or unplanned fire incident. At parks with cultural resources, park fire personnel will receive cultural resource protection training. At parks that have wildland or structural fire programs, cultural resource management specialists will receive fire prevention and suppression training and, where appropriate, will be certified for incident management positions commensurate with their individual qualifications.
- Smoking will not be permitted in spaces housing museum or library collections, or in historic structures (except those used as residences in which smoking is permitted by the park superintendent).

4. *Which Director’s Orders address protecting museum collections?*

Several Director’s Orders contain instructions related to protecting museum collections.

Director’s Order #9: Law Enforcement Program, vests considerable authority and responsibility in law enforcement staff for protecting park resources, including museum collections. It tells you to inventory your resources and prioritize protection needs after you assess their significance and vulnerability. It also discusses crime prevention and physical security programs in parks.

Director’s Order #28: Cultural Resource Management and Cultural Resource Management Guideline, Release No. 5 (1997), which implements Director’s Order #28, addresses protecting and managing all cultural resources, including museum objects.

- *Chapter 4* provides overall guidance on protecting cultural resources. The sections on physical security and structural fire relate to protecting museum objects.
- *Chapter 9* says a systematic approach to protecting museum objects involves:
 - identifying and evaluating threats and risks
 - conducting and reconciling annual inventories of collections
 - developing and implementing good operational procedures and practices, such as key control, access control, and opening and closing procedures

- evaluating the physical security of spaces housing collections, with attention to barriers, cases, locks, doors, and windows
- installing intrusion detection systems and fire detection and suppression systems that are appropriate to the nature of collections and the structures housing them
- incorporating the special needs of collections in physical security plans, structural fire plans, and emergency operations plans
- ensuring that all incidents involving collections are reported

Director’s Order #44: Personal Property Management and Personal Property Management Handbook #44, Section 9.3 governs firearms and ammunition that are part of a museum collection.

Director’s Order #50B and Reference Manual #50B, Occupational Safety and Health Program state the installation, inspection, and maintenance of fire sprinkler systems, fire alarm systems, life safety systems, smoke detectors, fire extinguishers, and other fire protection features will be in accordance with National Fire Protection Association (NFPA) requirements.

Director’s Order #58 and Reference Manual #58, Structural Fire Management tell you how to manage a structural fire program. Structural fire management is defined as the protection of people, content, structures, resources, and the landscape surrounding the structure from the effects of fire.

C. Measuring the Effectiveness of a Security System

Past experience is an important element. Complete and accurate loss records, such as Case Incident Reports, are vital. Nevertheless, past history does not tell the whole story. You also must:

- analyze the risk comprehensively
- evaluate the effectiveness of the countermeasures intended to reduce the risk
- determine how well the security system fits the operational needs of your park

All the elements are important. And remember, a system that reduces risk but paralyzes operations is not effective.

1. *What are the threats to museum collections?*

Figure 9.2 lists the threats to museum collections.

General Category	Specific Threat
Crime	Burglary Larceny Robbery Bombing Vandalism Arson
Civil Disturbances and Warfare	
Natural Catastrophes	Earthquake Flood Landslide Fire Hurricane Tornado Tidal wave Lightning Volcanic eruption Wildlife
Industrial Disasters	Explosion Structural collapse Hazardous materials release Fire Serious employee or visitor accident Nuclear incident Power outage Loss of water, sewer, or gas service
Other Threats	Accidental damage Acts by disturbed persons Transportation accidents

Figure 9.2. Threats to Museum Collections

2. *What is risk assessment?*

In assessing risk, you must analyze a threat's probability of occurrence and the severity of its consequences. You'll need to identify the possible ways losses can occur, what the impact of the losses would be, and how you prevent or reduce the losses.

Probability

While the number of potential threats is unlimited, some are more likely than others. In general, the more ways something can happen, the higher the probability it will happen. For example, consider a park with an extensive collection of Native American artifacts--pots, baskets, and other easily sold items. If the threat is theft, any of the following conditions, or some combination, increase the probability of a loss:

- Pots and archeological fragments on exhibit are not in locked exhibit cases.
- Objects on display are not routinely inventoried.
- There are no procedures for temporarily removing objects from exhibit cases.
- Exhibit cases have plain glass and standard fasteners.
- Exhibit spaces have large windows close to the ground.
- Door locks are not strong enough to prevent forcible entry.

- The building is not protected by an intrusion detection system.

Some threats are unlikely in some parks. For example, a park in New Mexico doesn't need to plan for a tidal wave. Some threats just seem unlikely. For example, a 500-year flood may seem to be a remote threat. But if we remember that the objective of the NPS preservation program is to preserve museum objects and historically significant structures for as long as possible, a 500-year flood is a threat that deserves thoughtful planning.

Severity

Highly probable threats may not require much in the way of preventive measures if the net loss or damage they would cause is small. On the other hand, moderately probable or greater threats demand greater attention if the impact would be great. For example, it is highly probable that someone will take the ball point pen from a visitor registration desk, but it is more cost-effective to use cheap pens, and replace them, than to prevent the loss. On the other hand, a low to moderate probability of arson in an historic structure demands full protective measures because the impact could be significant.

You can measure the impact of a loss by the direct cost, or dollar value, of the lost or damaged property and the cost of its repair or replacement. Direct cost is quantifiable and can be used to evaluate the cost-effectiveness of potential countermeasures. However, it may not be the most important measure, because the indirect costs may have a more severe impact on the park's mission. Indirect costs could include:

- effects on employee morale and reputations
- effects on public relations
- loss of donations to parks that do not protect their assets
- adverse impacts on the park's interpretive program

For example, a soldier's diary may have little dollar value, but it can play a significant part in telling the story of how the soldier lived and how soldiers in general took part in the development of the country. The diary serves both as an information resource and as a tangible point of reference to help visitors relate to the story. The fact that the diary is an original object enhances the relationship. If the diary is stolen, the interpretive story suffers in ways that cannot be translated into dollars.

3. *How do I conduct a risk assessment?*

First, you need to identify the potential threats or hazards that have the greatest probability of occurring and those with the greatest adverse impact on the museum collection.

Then look for irreplaceable, valuable and particularly sensitive objects, especially those on exhibit, such as historic firearms and paintings.

Finally, analyze the nature and effectiveness of the protection currently given such objects. For example, if you want to assess how well an object is protected from theft, try to think like a thief.

- A thief has to touch an object with something--hand, stick, wire hook, an accomplice--to steal it. Look at obvious ways first. In one theft from a park, the thief removed a diary from a case by tilting up the unsecured vitrine cover.
- If the case is small or poorly mounted, the thief might take both the case and the object in it. Look carefully at how cases are mounted. The case may be strong, but the wall mounting may be weak so the thief can pull the case off the wall, or remove it by taking out a few fasteners. So ask yourself:
 - Are doors and cases locked?
 - Are cases structurally sound?
 - Are fasteners firmly in place?
- After checking the obvious, be creative. A thief is not restricted by our concept of what someone might do, only by what it is possible to do. In one incident, a thief boosted a small child over a Plexiglas™ barrier that covered all but a small space at the top of a door into a period room. The child gathered objects and escaped through another door.

4. *How can I limit the risk?*

If possible, eliminate threats; if not, reduce them by:

- **Risk Assumption** is the process of using existing resources to absorb losses as and when they occur. It may be appropriate under the following conditions:

The impact of a loss is small. For example, it is advisable to assume the risk of some forms of vandalism.

The likelihood of damage is small. For example, it takes considerable effort to damage a stone-grinding wheel. Even if the grinding wheel is original to the site it may not make sense to exhibit it in a case, or even in a building, when it is easier to see outside and the wheel's size and composition make it nearly indestructible.

- **Risk Transfer** is the process of transferring a risk to another entity for a fee. It is usually not appropriate because the NPS generally insures property only when it is borrowed from someone outside the government or another government agency.

See the Museum Handbook, Part II, (MH-II) Museum Records, Chapter 4, Inventory and Other Special Instructions for guidance on insuring borrowed objects.

5. *How often should I assess risk and what tools are available?*

Director's Order #24: NPS Museum Collections Management requires parks and centers to keep the NPS Checklist for Preservation and Protection of Museum Collections (Checklist) up-to-date in the Automated Checklist Program (ACP) in ANCS+. The Checklist records information on preservation and protection conditions (including fire and security protection) in parks and centers, identifies deficiencies, and provides estimated costs to correct deficiencies. You can use the checklist to conduct a self-assessment of your park's level of museum security and fire protection. See Appendix F: NPS Museum Collections Management Checklists, and the *Automated National Catalog User Manual*, Appendix G: Automated Checklist Program, for guidance on the checklist.

6. *How do I conduct a self-assessment?*

Conduct a **Basic Security Inspection** by using the checklist as a guide to inspect museum collection spaces. There are three steps in this inspection.

- Describe the nature of the museum collection, to include:
 - types of materials used, such as paper, wood, or stone
 - value of objects (for example, monetary, research, interpretation)
 - most significant objects in the collection (for example, letter signed by President Truman)

See the NPS Museum Handbook, Part II, (MH-II) Chapter 4: Inventory and Other Special Instructions, Section IX, Determining the Monetary Value of Museum Objects, for guidance in establishing value.

- Identify the areas where the collection is kept (such as visitor center exhibit, storage), especially the most valuable and most vulnerable objects.
- Inspect for deficiencies using the NPS Checklist for Preservation and Protection of Museum Collections.

7. *What is a security survey?*

Use a **security survey** in the on-site phase of preparing a Collection Management Plan or as a specific need in a self-assessment inspection. Do not forget to include fire protection.

A comprehensive security survey will cover:

- perimeter security
- structures housing the collection
- policies and procedures
- emergency plans
- individual object protection

- fire prevention
- personnel training programs
- structural and procedural fire hazards
- maintenance of protective systems

Either you or a contractor can conduct the survey. Whoever does so must have the following qualifications:

- experience and expertise in protecting museums and historic sites
- sensitivity to the special protection requirements in museum operations
- practical experience in applying the requirements in parks and historic sites

8. *How should I prepare for a survey?*

Write a detailed scope of work (SOW) that serves as a blueprint for the survey and as a standard against which to measure the surveyor's work. See *MH-I*, Appendix G: Protection of National Park Service Museum Collections, for a sample SOW. The scope of work should specify what the surveyor is expected to do, and when, and how to report results.

Make sure all facilities with museum collections will be available during the survey. Brief park staff on the importance of the survey and ask everyone to answer questions candidly.

Prepare the following documents for the surveyor:

- most recently-completed NPS Checklist for Preservation and Protection of Museum Collections
- reports from any earlier security surveys
- plans and drawings of all facilities that house museum collections on which the surveyor will record observations to be included with the final report
- information on installation, operation and maintenance of the existing intrusion, fire detection, and fire suppression systems

Schedule meetings with the superintendent and key security, fire protection, and museum staff at the beginning of the survey to discuss its scope and at the end to discuss findings and recommendations. Also, schedule blocks of time for key staff members to spend with the surveyor during the site visit.

9. *What should the survey report include?*

From the site visit, the surveyor will:

- identify potential threats
- perform a risk analysis

- determine which losses are most likely and which would have the greatest impact
- establish priorities for correcting deficiencies

The final report should include:

- recommended improvements
- countermeasures that correct more than one problem
- alternatives for correcting deficiencies
- estimated cost for each recommended action

10. *What is the final and most important step?*

The last and most important part of your security survey will be the corrective action plan you will develop and implement afterwards. Take corrective actions that do not require funds, such as changing operating policies or procedures, immediately. Changes that can be made at a small cost also should be made relatively soon, while changes that require significant funding must be programmed. See *MH-I*, Chapter 12: Curatorial Programming, Funding, and Staffing, for guidance on programming. Naturally, if money is available, the most serious deficiencies should be corrected first. If funding is a problem, many corrective actions can be implemented in stages, or you may want to use the funds that are available to correct several less severe risks. The combined improvement from correcting several small problems can often outweigh the effect of correcting one large one.

If you discovered weaknesses in your security system, your corrective action plan should have taken care of them. If on the other hand, your security system works, stick with it, make minor improvements on the margin, and continue to self-assess on a regular basis.

But what if you need a new security system, in whole or part? The sections that follow in this chapter will help you design effective fire protection and security systems.

D. Fire Protection

Fire can destroy a park's museum collection in a matter of minutes. While a stolen or damaged object might be recovered and stabilized, burned objects, and sometimes even those just exposed to smoke and heat, may be lost forever. Human error, arson, deteriorating electrical and mechanical systems, and congested storage areas are only a few of the conditions that can increase the threat of fire.

Museum management staff should take a hard look at the park's Structural Fire Plan to make sure it addresses the needs of the museum collections.

1. *Who is responsible for fire protection?*

Preventing fire is a fundamental responsibility for every member of the Park Service, and each employee is responsible for:

- maintaining well-organized storage and work spaces
- storing all flammable materials in approved containers outside spaces housing museum collections
- keeping fire exit routes open and clear
- enforcing a no-smoking policy in museum spaces
- controlling ignition sources, such as fires in the fireplace of a historic structure
- practicing good housekeeping
- checking electrical and mechanical equipment for defective components, improper installation, and overloaded circuits
- correcting or reporting fire hazards

Managers have the following additional responsibilities:

- Training all employees in the elements of fire safety, fire prevention, and emergency response with emphasis on:
 - duties in the event of fire or other emergency
 - how to notify the fire department and other emergency response personnel
 - procedures for evacuating visitors and employees
 - special considerations for protecting museum collections
 - location and use of fire extinguishers, fire detection equipment, and fire suppression systems, including the location of sprinkler control valves and how they operate
- Consulting with the local fire department and acquainting fire-fighting personnel with the museum collection and its special needs.
- Being aware of the major causes of fires in parks and museums, as listed below in Figure 9:3.

Major Cause	Average Fires/Year
Electrical Distribution System	22
Incendiary or Suspicious Causes	17
Other Equipment	10
Open Flame	8
Heating Equipment	7
Smoking Material (e.g., cigarette)	7
Cooking Equipment	6
Exposure (to other hostile fire)	4
Natural Causes (lightning, etc.)	4
Appliance, Tool, or Air Conditioning	3
Other Heat Source	1
Child Playing	<1
Total	89

Figure 9.3. Major Causes of Museum Fires¹

2. *What are the precautions for construction and renovation?*

The National Fire Protection Association (NFPA) Technical Committee on Protection of Cultural Resources says: "Experience shows that the hazard of fire is increased when a museum is being renovated...."²

These are only a few of the fire hazards associated with construction and renovation:

- spontaneous ignition of rags used for painting, cleaning and polishing
- careless smoking
- torches and other open flames
- escaping flammable gas
- improper storage and use of flammable and combustible liquids
- poor housekeeping

You must be vigilant during periods of construction and renovation to maintain high standards of housekeeping and to control potential ignition sources.

3. *What about open flames in structures?*

You need to recognize the increased number of fire emergencies due to open flames, such as campfires, candles, lanterns, fireplaces, and stoves that are popular elements in living history programs. You should ensure that the park has written procedures that include:

- Open flames will never be left unattended.

- At the end of the day an appropriate screen will be placed across the opening of any fireplace where there has been a fire that day.
- An appropriate fire extinguisher will be within easy reach when open flames are used inside a building.
- Staff will be trained to use open flame devices properly.
- Fires are not permitted in fireplaces or stoves with unlined chimneys.
- Active chimneys will be inspected and swept annually.

4. *What's the threat from fires?*

When a fire starts, the temperature in the room of origin can be lethal in two to three minutes, and everything combustible in the room can ignite in as little as four to five minutes. If the fire continues to build for another ten to fifteen minutes, chances are the structure will suffer significant damage.

Even a quickly extinguished fire will damage fragile objects. By the time the fire department starts manual suppression, museum objects close to the room of the fire's origin will be damaged or destroyed unless there is an automatic suppression system. When fire fighters start manual suppression, they will pump water on the fire through two or more hoses, each delivering 125–250 gallons per minute. But even a well-trained fire department located close to a burning structure requires more than 10 minutes to:

- receive the alarm
- travel to the site
- set-up equipment
- search for occupants
- find the origin of the fire
- begin manual suppression

5. *What should a structural fire plan cover?*

You need to ensure that your park's Structural Fire Plan includes protecting museum collections. The overall plan should address preventing, detecting, and suppressing fire throughout the park. The section of the plan that deals specifically with museum collections should also include the following:

- a memorandum of agreement with the local fire department calling for mutual cooperation in preparing a pre-fire plan for each structure

Curatorial staff should be involved in planning and have input into developing fire department response and salvage plans. See *MH-I*, Appendix G: Protection of National Park Service Museum Collections, for a sample memorandum of agreement.

- operating and maintaining any automatic suppression systems

- a list of personnel designated to respond to a fire involving museum objects and their specific responsibilities
- training all park staff in procedures to follow in the event of a fire to minimize damage to museum collections
- a plan to relocate important objects in the collection to a pre-designated secure location

6. *How do I limit fire risk?*

By preventing, detecting, and suppressing fire.

7. *What constitutes a good fire prevention program?*

Do these three things:

- **Prevent ignition:** The employee responsibilities listed above accomplish this. Unfortunately, people still make mistakes, and some things are always beyond our control. Between the two, fires will happen.
- **Prevent fire spread:** When a fire starts, prevent its spread by
 - limiting the amount of fuel available
 - confining the fire in a space with a limited amount of oxygen
 - activating an automatic fire suppression system

Barriers can limit the spread of fire, smoke, and other combustion products.

An enclosed stairway is an excellent example of a structural feature that serves both as a fire and a smoke barrier. Open stairways act as chimneys in a fire, drawing flame, smoke, and products of combustion from one floor to another. Well fitting doors on each floor can prevent the spread of fire and smoke, but all it takes to compromise the protection is a single chocked open door.

And more than one closed bedroom door has protected a sleeping person from the effects of smoke and carbon monoxide.

- **Prevent fire from reaching vulnerable objects:** If you've used properly designed storage containers, you can protect vulnerable objects or records from fire for a time. For example, a locking, insulated safe, filing cabinet, or vault designed to maintain an interior temperature of less than 350°F during a one-hour exposure to exterior temperatures of at least 1700°F can protect paper accession records. Similarly, a media box that will maintain an interior temperature of not more than 125°F during a one hour exposure to an exterior temperature of 1700°F can protect floppy disks or magnetic tapes, such as those used to back up the Automated National Catalog System (ANCS) data files.

8. *Is a fire detection system essential?*

Even with the best fire prevention program, you will still need a good fire detection system. Human error, natural conditions, and deterioration of buildings and systems almost guarantee a fire at some point, and life safety concerns alone demand rapid detection in an occupied structure.

Consider the following factors to determine fire detection needs:

- significance or value of the collection
- construction of the building
- nature of the collections
- number of occupants and what they are doing
- time needed to evacuate
- likely speed of fire spread
- time it will take to start suppressing a fire
- types of fire detectors available

9. *Who should monitor a detection system?*

A fire detection system only provides information. Someone who can use the information to send help must monitor it constantly. If the park does not have the staff or equipment to do this, the system should be monitored by the local fire department (if they provide this service, and someone is always there) or by a commercial central station that is listed by Underwriter's Laboratory (UL).

Sometimes parks in remote areas do not have access to a UL-Listed central station. In these instances, an unlisted facility may be adequate. You should make sure that the unlisted facility has enough staff to monitor alarms constantly, uses reliable equipment, and provides training to its staff.

10. *Why should I contact the local fire service provider?*

There are several advantages to contacting the local fire service provider. These contacts should be initiated during normal business hours so that they will not have to occur under the pressure of emergency operations. The advantages include:

- learning the availability of expertise for fire prevention inspections and code enforcement
- providing company inspections (orienting and familiarizing each shift)
- identifying the key person and contacts
- training/drills (joint activities to include day/night operations; business open/business shut down; seasonal - summer/winter)
- pre-fire planning (focusing on floor plans, access, utility shut-off locations, and sensitive items/areas)

11. *What types of fire detectors are available?* The types of fire detectors normally used to protect museum collections and historic structures are listed in Figure 9.4.

TYPE	BEST USE OF THE DEVICE	WHERE SHOULD IT BE LOCATED?	THINGS TO AVOID
Photoelectric Smoke Detector (Spot Type)	To detect slow, smoldering fires that generate large amounts of visible smoke	<ul style="list-style-type: none"> • On the ceiling or wall at least 6" from the junction of the ceiling and wall • In the path of air circulation where smoke will reach the detector 	<ul style="list-style-type: none"> • Locating detector directly in the path of air from an air supply or return grill • Hot (>100°F) or very cold (<32°F) spaces • Dead air spaces • Spaces where steam or smoke are expected-- boiler rooms • Within 8' of an active fireplace • Dusty areas • Outside <p>NOTE: New detectors have protective screens to keep out insects. Very small spiders can still get into these detectors and cause false alarms.</p>
Photoelectric Beam Smoke Detector (Line Type)	<ul style="list-style-type: none"> • Large open spaces (30'x30' or greater) with high ceilings (>12') • Slow, smoldering fires 	<ul style="list-style-type: none"> • Large gallery spaces • Auditoriums 	<ul style="list-style-type: none"> • Mounting detectors low (generally below 8') if the beam is broken or partially blocked the detector goes into alarm • Same conditions as spot type photoelectric detector
Ionization Detector (Spot Type)	To detect fast, flaming fires that may not generate much visible smoke	Same as spot type photoelectric smoke detector	Same as photoelectric NOTE: Insects are not a problem with ionization detectors, but they are much more sensitive to steam or the fine products of combustion normally found in boiler rooms.
Air Sampling Smoke Detector	Areas where very early detection is vital--these detectors are intended to react before fire reaches the flaming stage	High value areas such as vaults, or sensitive areas such as computer facilities	Where candles, fireplaces, wood stoves, or any other open flame will be used regularly
Flame Detector	Same as air sampling detector--frequently used in explosion-detection systems	Where large concentrations of flammable or combustible gas or dust are found	Same as air sampling smoke detector
Heat Detector	Spaces where environmental conditions cause unwanted alarms from smoke detectors, or where conditions (heat, cold, humidity) will damage electronic devices.	Same as spot type photoelectric or ionization detector	Where life-safety is the major concern--sleeping quarters, etc.-- Heat detectors are not approved for life-safety applications.

Figure 9.4. Types of Fire Detectors

12. *What about maintenance and testing?*

A fire detection system needs routine maintenance and testing to keep it operating as designed and expected.

- Dirty smoke detectors are the most frequent cause of unwanted alarms.
- The control panel can fail, or operate erratically, particularly in areas prone to lightning or unreliable electric power.
- Evacuation alarms may fail, or people may not be able to hear them everywhere in the building.
- Telephone lines may fail, and dialers fail regularly.

Test and maintain fire detection systems in accordance with the requirements of NFPA 72, *National Fire Alarm Code* (listed in Section K).

13. *How important is fire suppression?*

A fire detection system is effective only if detection is followed by **suppression**, such as fire extinguishers, stand-pipe, response by fire fighting personnel, or an automatic sprinkler system.

14. *Are fire extinguishers enough?*

An employee with a fire extinguisher often is the first line of defense when a fire starts. But first:

- Evacuate the building.
- Notify the fire department by the fastest available means, such as telephone, manual fire alarm.
- Fight the fire.

Fire produces carbon monoxide and other toxic gases that affect judgment and coordination and are the major killers in fires. So, attempt to fight a fire only if you are in good physical condition, are trained, and properly equipped.

15. *Who should know how to use a fire extinguisher?*

Every employee should know how to use the park's fire extinguishers and where they are located. OSHA Regulation Standard 29CFR, Standard Number 1910.157G1 states, "when the employer has provided portable fire extinguishers for employee use in the workplace, the employer shall also provide an educational program to familiarize employees with the general principles of fire extinguisher use and other hazards involved with incipient stage fire fighting." Standard 1910.157G2 states that, "the employer shall employ the education required upon initial employment and at least annually thereafter."

Training also should include instruction on the proper types for the most likely kinds of fires. Fire extinguishers have a label with a letter (**A**, **B**, **C**, or some combination) that tells the user what class fire it is designed to extinguish. See NFPA 10, *Portable Fire Extinguishers*, for additional information.

16. *What is the most common type of extinguisher?*

The **ABC** multi-purpose dry chemical extinguisher is the most common type in parks because it is safe for use on all fires except those involving combustible metal. Multi-purpose dry chemical extinguishers use a fine powder, similar to baking soda, to smother fire. Not all dry chemical extinguishers are multi-purpose. **Purple K** dry chemical extinguishers are designed for flammable liquid fires and may harm some objects.

Don't use Purple K dry chemical extinguishers in museum spaces.

17. *What about Halon extinguishers?*

Many parks, concerned about the residue from dry chemical extinguishers, installed Halon 1211 or 1301 extinguishers in museum collection spaces. Halon is an ozone-depleting substance. As of January 1, 1994, the United States, and the other signatories of the Montreal Protocol, in order to protect the earth's ozone layer, stopped manufacturing halon and added a heavy tax to new halon imported into the country. It has not been banned, and there is no immediate reason for parks to remove their halon extinguishers. Halon is still available and will be for some time. Still, in time halon will become hard to get, and it will be expensive. Prudence, as well as concern for the environment, suggests that you should replace halon extinguishers with other types (multi-purpose dry chemical or CO₂ extinguishers) as they are used or start to leak.

18. *What are the maintenance and testing requirements?*

Fire extinguishers should be checked monthly and must be inspected annually. See NFPA 10, *Portable Fire Extinguishers* (listed in Section K) for maintenance and testing requirements.

19. *What about standpipe and hose systems?*

A standpipe hose in untrained hands is a liability, can increase the amount of fire and water damage, and may place the person using it at risk of serious injury or death. Only physically capable, properly equipped, and properly trained employees should use a standpipe hose to fight a fire.

20. *What about sprinkler systems?*

A standard sprinkler system operates when a sprinkler head reaches its design operating temperature and opens. One sprinkler head opens at a time delivering about 25 gallons of water per minute to the fire. Most fires in sprinklered structures are controlled with five or fewer sprinkler heads opening. There are four types:

- **Wet pipe systems** generally are not used in spaces where the temperature drops below 32°F. An experienced fire protection specialist should evaluate the conditions before the park decides to use one of them.
- **Dry pipe systems** are designed for use in spaces where the temperature does fall below 32°F. Some museums use dry pipe systems to protect storage and exhibit spaces because there normally is no water in the pipe.
- **Pre-action systems** may be installed in areas where freezing or mechanical damage to sprinkler heads or pipes is likely. The disadvantage of a pre-action system is that when the fire detection

system fails, or is out of service, the sprinkler system can't operate automatically. Routine maintenance on a pre-action system also is more complex and time consuming than on other types of sprinkler systems

- **Cycling systems** turn off when the fire is out. If it depends on the fire detection system, it also can't operate automatically when that system is out of service. Some cycling systems have a separate detection system to control the sprinklers. In either case, maintenance of the system is complex.

Before selecting a sprinkler system, a structure's construction, environmental conditions, space, nature of museum collection, and protection priorities need to be studied. Consult with a qualified fire safety professional before deciding which type of system best suits your needs.

21. *What about water damage and accidental discharges?*

When there is a fire in a sprinklered structure, only those sprinkler heads exposed to heat (usually between 165°- 225°F) open and discharge water individually to extinguish or control the fire, thereby limiting to some extent possible water damage.

Sprinklers with higher temperature elements are available for special applications, such as protecting foundries, food preparation areas, or other higher temperature environments.

Curators frequently ask about potential collections damage from an accidental sprinkler discharge. Nearly all documented accidental discharges happened because of:

- improper design
- improper maintenance
- human error

Maintenance and testing is a particularly important element in preventing accidental sprinkler discharges. NFPA 25, *Inspection, Testing and Maintenance of Water-Based Fire Protection Systems*, lists and describes the requirements (see Section K).

A sprinkler system also has to be monitored. When the fire is out, someone has to turn the system off and restore it to service.

One way to limit the amount of water a sprinkler system discharges after the fire is out, without installing a complex cycling system, is to use on-off, or controlled flow, sprinkler heads on a wet pipe system. Although they cost 5-10 times more than a standard sprinkler head, controlled flow heads may add only 5%-15% to the total cost of the system.

22. *What about other automatic suppression systems?*

Halon 1301 systems are still being used in some NPS suppression systems and portable extinguishers. Since the Montreal Protocol, however, the NPS's policy is not to install any new halon systems and to program for replacing existing systems.

The fire suppression industry is experimenting with Halon substitutes, and several have been approved. Ansel's **Inergen™**, Dupont's **FE 13**, and Great Lakes Chemical Corporation's **FM 200™** are the most popular. However, they are not drop-in replacements. To use any substitute now available in an existing halon system, you must modify the pipes, agent storage tanks, or discharge heads.

Carbon dioxide systems extinguish fire by reducing the oxygen content of the space below the point that it will support combustion or life. Thus, people must evacuate before the gas discharges or they may suffocate. Carbon dioxide is best for suppressing surface fires in service, utility, or other unoccupied areas.

23. *What do I need to know about installing mobile compact shelving?*

As parks seek to make better use of existing space, more and more of them are installing mobile compact storage systems to store museum objects. These systems eliminate fixed aisles and can expand a room's storage capacity as much as 40%. Combustible objects, records, books, and manuscripts stored in compact shelving units increase the fuel load in the room: there is more to burn, it will burn longer, and it will burn hotter. There are considerable fire risks. Before installing such shelving:

- A qualified structural engineer should evaluate the floor load-bearing capacity of the space. If the space is above grade, assess the potential impact of a fire on the floors below and above.
- A qualified fire protection specialist should evaluate the adequacy and effectiveness of systems to detect and suppress fire considering the potential for a concentrated fire load.
- You should consider modifying opening and closing procedures to include leaving open space between mobile shelving units when the area is unoccupied.

Mobile compact shelving units in the fully closed position delay both detecting and suppressing fire inside the shelving module. Closed, the shelving modules hold smoke and heat inside and can prevent water from reaching the fire to extinguish it. In a study conducted for the General Services Administration (GSA), and in later studies conducted for the National Archives and Records Administration (NARA) and for the National Library of Canada, tests showed that a fire can burn inside a closed shelving module for an hour and a half, or more, before activating ceiling mounted smoke detectors. Sprinkler operation is delayed, as well. The NARA and Canadian studies found that when compact storage modules are completely closed, severe fire damage will occur in more than one shelving module, even when fire detection and automatic suppression systems operate as designed.

Both tests showed that a small open space between shelving units reduces fire damage. NARA uses a computer-controlled system in Archives II to leave a 9" opening between the shelf units when the facility is closed or when the fire detection system activates. The Canadians use rubber bumpers to keep an opening of 1½ - 2 inches between shelving units, and a sprinkler system that puts a large amount of water on the fire quickly. Both methods prevent the spread of fire to other shelving modules and limit damage to materials on the shelves where the fire starts.

24. *What about salvage after the fire?*

After a fire, successful salvage operations require immediate action as long as they do not hinder suppression operations or compromise life-safety.

- In a fire, the fire department is in the best position to protect museum collections from damage. Museum staff should discuss these issues with fire-fighting personnel when they are preparing, or up-dating pre-fire plans for the building. Fire-fighting personnel need to know about particularly important or vulnerable objects, and they need help establishing priorities, i.e., what should be protected first.
- The park's Emergency Operations Plan (EOP) should include the following information regarding salvage for the museum collection.
 - temporary storage for museum objects removed from the fire area
 - location of protective coverings, such as salvage covers, and how and under what circumstances they should be used
 - names and telephone numbers of contractors who can make temporary repairs, provide emergency supplies, or provide salvage services such as freeze-dry units and water extraction
 - how and where to purchase materials and supplies, how to pay for them, and how to move them
 - other sources of help (other parks, museums with similar collections that are close by, etc.)
 - instructions for placing security, fire detection and fire suppression systems back in service
 - procedures for the security, inventory and tracking of museum collections affected by the emergency
 - temporary measures to protect the collection and the structure until repairs are completed

25. *Where can I get help?*

- Consult your park or regional structural fire management officer. Specific technical assistance and information can be obtained from the following National Park Service offices:
 - Structural Fire Chief, NPS Fire Program Management Center, National Interagency Fire Center (NIFC), Boise, ID
Telephone: 208-387-5209
FAX: 208-387-5250
 - NPS Safety Engineer, Denver Service Center, Technical Expert, Safety and Codes, Denver, CO
Telephone: 303-969-2196
FAX: 303-969-2930
 - NPS Risk Management Division, Washington, DC
Telephone: 202-208-6350
FAX: 202-208-6756
- The security or protection services departments in most large museums, such as the Smithsonian Institution, give advice and answer questions.
- Invite your local fire department to inspect spaces housing museum collections. Consult regional, county and State Fire Marshall's offices and Fire Prevention Bureaus for additional information and guidance on fire safety.
- You should obtain copies of the National Fire Protection Association's recommended practices. These documents contain useful information on fire prevention, detection, suppression, and safety self-inspection. See Section K for a list of these publications.

E. Operational Security

When designing a new security system, or redesigning your existing one, you will want to reduce or remove the risks you have identified. Then you can develop and implement your day-to-day operating procedures, as well as your emergency procedures. Finally, you will need to train the staff on the new or revised system.

1. *What are some of the design issues I should consider?*

The value of cooperation in security planning is never more apparent than in the design phase of a new project--a new exhibit, a new storage facility, or refurbishing and restoring a historic structure. Working together, curators, security specialists, architects, engineers, exhibit designers, historic preservation specialists, interpreters, maintenance personnel, and fire safety professionals often can resolve security issues before they become a problem. Before you start work, prepare a written list of minimum security standards to include:

- proximity of staff to the exhibit area
- tours--size, type (self-guided versus staff-guided) and tour route

- proximity of exhibit objects to the tour path
- features that limit public access to exhibits

The Architectural Barriers Act of 1968, Section 504, and the Americans with Disabilities Act of 1990 require museums to be as accessible as practicable, both architecturally and programmatically. The NPS has installed equipment to make structures accessible to the mobility-impaired. In some historic structures, for example, access equipment is located out of public view to minimize the visual intrusion, and disabled visitors are routed through otherwise closed spaces. In the rare instances where an alternative access route goes through exhibit spaces, the planning team must consider the impact on the security of exhibit objects and their vulnerability to accidental damage.

- security issues raised by making exhibits accessible for people with disabilities
- vulnerability of exhibit objects to theft, vandalism, touching and accidental damage

You should resolve these and any other security issues before the design is approved to avoid the need to make costly corrections later.

Be aware that technology is developing so fast in some areas (such as computers and detection systems) that it may make sense to select the technology as close as possible to completion of the project, provided this does not require significant changes in the structure.

Finally, document **all** decisions.

2. *What should I cover in our day-to-day operational policies and procedures?*

The need for these detailed, day-to-day policies and procedures is to control access to vulnerable objects, a key element in your security program. The key in protecting museum collections is to allow reasonable access without creating undue risk. How? By controlling legitimate access while preventing unauthorized or unnecessary access.

Security programs depend on trusted agents, such as our Park Service employees, but even so, one individual should not have the freedom to care for and account for museum collections without routine oversight by someone who understands the system well enough to spot discrepancies. Your access control policy must include inspection, oversight, and audit safeguards to reduce the risk.

3. *What should I include in an access policy?*

When writing an access policy, include the following elements:

- statement of purpose
- general access procedures

- general guidelines for employees, scholars, researchers, visitors, service vendors, emergency response personnel, and others who are eligible for access to the museum collections
- conditions that justify access
- superintendent's signature

See *MH-I*, Appendix G: Protection of National Park Service Museum Collections, and *MH-II*, Appendix D: Museum Archives and Manuscript Collections, for sample access policy and procedures.

4. *What else should I do regarding access?*

- Know the people who have access to the collection. The more access someone has, the more you should know about him or her.
- Look for other ways for the person to accomplish his or her objective without allowing access to original pieces.
- Specify how someone receives authorization for access to collections:
 - Who is authorized to grant access?
 - How much access can they grant (i.e., escorted, unescorted)?
 - What justifies granting access?
 - When are escorts required?
- Keep access lists up-to-date and make sure they are used routinely.
- Specify minimum parcel control procedures:
 - Limit the size of parcels visitors are allowed to carry into collection areas (anything larger than 11" X 15" can be a problem).
 - Search parcels larger than 11" X 15" if they are taken into research or non-public areas by non-employee researchers.
 - Use property passes to identify personal property taken out of the building by employees.

5. *Why should I be concerned about key control?*

Barriers and locks are the most common tools used to accomplish the objectives of your access control policy. While keys are a symbol of trust, as well as a way of controlling access, the key as status symbol sometimes overrides the importance of the key as a tool for access control.

The fewer keys there are, the better.

- Keys multiply over time, particularly at the master and grand master levels. Unchecked, this quickly compromises the access control program.

- Good key control requires ongoing maintenance and cooperation by all staff.
- Lost or stolen keys to museum collection spaces, such as storage or exhibit cases, increase the risk of loss.
- Lack of accountability invites unauthorized possession and duplication of keys.

6. *How do I control keys?*

Ask your superintendent to sign written procedures that:

- Designate one person as responsible for controlling keys, including issuing or transferring keys, having keys made and inventorying keys annually.
- Designate, by name, those authorized to have keys to museum collections storage spaces and exhibit cases.
- List the responsibilities that go along with having park keys:
 - safeguarding keys
 - reporting lost keys
 - returning keys when they are no longer needed
- Require a signed and dated Receipt of Property Form, DI-105, or its equivalent, when keys are issued.

7. *What should I do to safeguard keys?*

First, decide where and how to store spare keys and operational keys that remain on-site; then, think about off-site concerns.

In an ideal world, no keys would leave the park, but this is almost never possible, therefore:

- Designate which keys employees can take off-site.
- Specify limitations on taking keys off-site (overnight versus a two week vacation).
- Restrict the number of keys that leave the park, and be sure that grand master keys never leave the park (if lost or stolen the whole key system is compromised).
- Place keys to museum exhibit cases and specimen storage cabinets in a key cabinet (located in museum storage, where possible) or some other appropriate locked container at the end of each day.
- Limit access to the curatorial key cabinet to the curatorial staff.
- Keep other keys in a key cabinet in a protected space that is convenient for opening and closing.

- Lock up any keys that are not in use.
 - Store spare removable cylinder cores and core removal keys in a safe, preferably separate from key blanks.
8. *What about access to keys in emergencies?* Specify in your key control policy who may obtain keys in an emergency, how to get them, and where they are kept.
9. *How do I ensure accountability?*
- Develop audit and inventory procedures.
 - Report results of the inventory to the superintendent.
 - Review key control records annually to make sure they are current.
 - Make sure all museum keys are returned by transferring museum employees.
10. *What should I do if a key is lost or stolen?* When a key is lost or stolen, the only sure way you can protect the facility is to rekey every lock it opens. If the missing key is a master, or grand master, then you should rekey all the locks.
11. *Are combination locks better than keyed locks?* Combination locks have many applications. File cabinets and secure areas used by a large number of employees often have combination locks. The gate to a vehicle storage area is an example. Other applications include very high security areas, such as safes and vaults, where the physical existence of the key poses a threat because of its vulnerability to loss, theft, or unauthorized use.
- Combination locks have advantages and drawbacks. For example, while it is easier and less costly to change a combination than to rekey a lock, these locks can also be greater security risks. Why? Because many find it difficult to remember random number combinations. They:
- write down the combination (a quick look around a safe or file cabinet often turns up the combination written on something close by),
 - use number combinations that are easy to defeat, or
 - use birth dates or other number combinations easily associated with the safe's custodian.
- Because of such security concerns, be sure that you change combinations annually, or when anyone with the combination transfers or quits, or whenever evidence suggests the combination has been compromised.
- Also, you will want to seal a written record of the combination in an envelope designed to show evidence of tampering and keep it in another safe. Finally, do not forget to protect change keys/wrenches and the instructions for changing combinations from unauthorized use.

12. *What should I include in opening and closing procedures?*

The best access and key control programs in the world are of no value if you do not open or close the facility properly. Written opening and closing procedures provide a checklist for transitioning from one condition to the other and, at a minimum should:

- Identify who may open or close.

If you designate who has authority to open a building or controlled area, you establish both the responsibility and the authority to control access.

- Specify locking and unlocking sequences and paths.

There should be a clearly defined entry and exit procedure. The person opening the building should enter at a designated point, and the person closing the building should leave the same way.

- Require checking for stay-behinds.

Don't forget to inspect the building for someone trying to stay behind after closing.

- Buildings often have places someone can hide (closets, stairways), so the first step to prevent a stay-behind is to keep potential hiding places locked while visitors are in the building.
- For potential hiding places that cannot be locked, consider local daytime intrusion detectors to alert staff when someone enters them.
- When closing the building it is important to search it in a systematic way--start at the top, work down and out.
- Where possible, lock areas of the building as they are inspected to prevent someone moving back into a space after it is inspected.
- Written procedures should highlight vulnerable areas for special attention.
- It may be possible in a large building to activate the intrusion detection system by areas to detect someone trying to get back into an inspected area.

See *MH-I*, Appendix G: Protection of National Park Service Museum Collections, for sample opening and closing procedures.

13. *What else should I include in the opening and closing procedures?*

Opening and closing procedures should include:

- Alarm system information--include arming and disarming sequences.

Don't include alarm codes in the written procedures.

- Doors and windows to be opened and closed.
- Mechanical system information--how to activate and secure, systems that should be on when the building is open and off when it is closed, location of controls, and how to operate them.
- Potential fire hazards--locations of coffee pots, hot plates, and other heat producing devices (all of which should be turned off and unplugged at the end of the day).
- Opening procedures, such as the need to:
 - look for signs of unauthorized entry or theft
 - inventory particularly valuable or sensitive objects
 - check for unusual conditions (e.g., leaks in roof)
 - make sure all objects on exhibit are in place
 - make sure cases are locked
- Other site-specific conditions that require attention.

14. *What about the park's crime prevention and physical security plans?*

The park's crime prevention program should include:

- leadership and participation by management in developing and operating the security program
- regular security surveys by qualified personnel and provisions for corrective actions
- orientating and training all employees (permanent, temporary, seasonal, and volunteers) in security awareness, with emphasis on each employee's security responsibilities
- an appropriate level of security for all park property-- including museum collections, capital equipment, supplies, buildings, money, firearms, and historic sites, monuments, and ruins
- procedures for guides, reception desk personnel, and cashiers to surreptitiously summon help in an emergency or when a visitor becomes unruly
- an annual review of the park's crime and security problems followed by implementing preventive measures
- appointing a full time or collateral duty Physical Security Coordinator

15. *What should I include in the Emergency Operations Plan?*

Be sure that protecting the museum collection is in the park's Emergency Operations Plan (EOP). See *MH-I*, Chapter 10: Emergency Planning, for guidance on museum collections emergency planning. Staff should be trained to act promptly in an emergency and should be prepared to remove museum collections after seeing to the safety of visitors and other staff.

The Emergency Operation Plan should include specific information regarding:

- command and control
- controlling access in an emergency
- location of emergency keys
- inventory and location of emergency supplies
- location and operating instructions for fire extinguishers, fire alarm equipment and other fire suppression and emergency response equipment
- emergency telephone numbers for assistance--both on-site (curators, conservators) and off-site (regional/SO personnel, other cooperating agencies and institutions, commercial recovery firms, and emergency response personnel)

16. *What should I include in staff training?*

The final and most important element in your operational security program is staff training. Written policies and procedures are valuable only if all employees know what they are and how to implement them. Staff training should be specific and cover all basic security practices. Hold mandatory training sessions regularly.

Be sure to include these topics in the training:

- importance of routine security measures, such as locking doors and windows when the building is unattended
- importance of routine inventories of objects on exhibit and in storage
- reminder that theft is preventable
- reminder that most thefts are spontaneous events that occur because of simple oversights
- importance of maintaining the integrity of non-public spaces by challenging those who are not members of the staff when they are in these areas without an escort
- fire safety
- routine and emergency operations
- use and maintenance of equipment

17. *Where can I get help?*

For additional information, contact your park or regional/SO protection staff and regional/SO curator. You can also consult:

- The security or protection services departments in most large museums, such as the Smithsonian Institution, for advice and answers to specific questions.
- The American Society for Industrial Security's (ASIS) Standing Committee on Museum, Library and Archive Security. Members of the Standing Committee will give advice on specific problems. Call ASIS headquarters at (703) 519-6200, or visit their website at <<http://www.asisonline.org>>. You can also order their publication *Suggested Guidelines in Museum Security*.

F. Physical Security

While the previous section of this chapter discussed the concept of designing for security, this section examines the specific physical security elements you can use to satisfy your security standards. You can also incorporate these elements into existing facilities to help remove or reduce threats.

1. *What is physical security?*

Physical security includes all measures intended to prevent acts of violence against persons and destructive or unauthorized access to or removal of property. Physical security elements deny, delay, or discourage criminal acts, and are the means for achieving the objectives of the access control policy.

Physical security is a **crime prevention** tool. Three factors have to be present for a crime to occur:

$MEANS + MOTIVE + OPPORTUNITY = CRIME$
--

The criminal brings **MEANS** and **MOTIVE** to the crime. There is little we can do to remove them from the equation. We can use physical security measures, however, to remove or limit **OPPORTUNITY**.

2. *What are the tools of physical security?*

There are many, but the primary ones are:

- barriers
- locks
- lights

3. *Why do I need barriers?*

Barriers limit access by delaying the intruder, by making the intruder visible, or both. Given enough time a determined person can breach the most elaborate barrier, but you can discourage entry by increasing the time it takes and the chances of being seen, and by encouraging the thief to look for an easier target elsewhere.

Typical barriers might include:

- Park boundaries
 - natural barriers (e.g., ravines, mountains, water)
 - fences
 - well lighted open spaces
- Building structure
 - walls
 - foundations
 - roof
 - doors
 - windows
- Interior barriers
 - storage rooms
 - cabinets
 - vaults and safes
 - cases
 - temporary or permanent exhibit barriers

4. *How many barriers are enough?*

Figure 9.1 illustrates how you can use barriers to protect valuable objects:

- Add barriers, like the rings of the bull's-eye, to protect high value objects.
- The more valuable the object, the more rings you need.
- There have to be enough barriers to delay entry until the responder arrives.

5. *Why do I need locks?*

Properly designed and installed locks are one of the first lines of defense in a museum protection program. The locking system should not rely on

- warded locks
- spring latches
- deadbolts less than ¾" long

- key-in-knob locks
- locks installed with screws ½" or less in length

A lock is no better than the door it is on or the strike and jam the bolt fits into, and even the best quality lock is of little value without an active key control program.

Most historic structures have old style locks on exterior doors. Authenticity considerations do not allow changing to modern locks in most cases. Where this is true, the park should include additional protection features, such as alarms, to supplement the locks.

6. *What criteria should I use in selecting locks?*

An effective locking system must fit the needs of the park and of the space it protects. Many types of locks are available, but they are not all equally effective in all circumstances. Isolated spaces and high security areas need heavy-duty locks.

7. *What is required for museum storage spaces?*

Museum storage spaces should have metal or solid-core wood doors. Each door should have:

- a dead bolt lock
 - 1" or longer bolt
 - exclusive non-mastered key code
- hinges located with pins are on the secured side of the door (When this is not possible, spot-weld the hinge pins so they cannot be removed, or replace the existing hinges with hinges that have non-removable pins.)

You may want to use a proprietary or regionally propriety keyway--a lock system with a keyway the manufacturer guarantees not to sell to anyone else within a specified area. Keys for a proprietary keyway must be made by the manufacturer, or the park must purchase specialized key cutting equipment. The advantage is that the local hardware store cannot duplicate the park's keys.

8. *Why is an effective lighting system important?*

Good lighting makes criminals nervous because it increases the chances of detection and identification. It has the opposite effect on employees and the public. Light increases the public's perception of the safety of an area and lets law enforcement patrols see what's going on and detect the physical signs of a break-in.

It is not the intensity of the lighting as much as the evenness of the illumination that makes a lighting system effective. The area should be free of glare and shadows. Lights close to structures should illuminate toward the structure, not out and away from the structure. A properly designed

lighting system eliminates hiding places and facilitates the ability of security patrols to observe.

9. *Is lighting always necessary?*

Under some conditions lighting may attract unwanted attention to the site. In isolated rural areas, for example, a well-lighted building in an otherwise dark landscape makes an attractive target. Some parks have found that lighting remote parking lots also can bring unwanted visitors, making the lots a local hangout. In both cases, you may want to use time-clocks so the grounds or parking lots are lighted when legitimate visitors are using them, but dark afterward.

10. *What about light for closed circuit television (CCTV)?*

Exhibit areas and visitor centers may use closed circuit television (CCTV) as a protection and control tool. A video recorder makes CCTV useful for after-hours protection by visually documenting unusual conditions. CCTV is also useful to those responding to intrusion or fire alarms. The cameras provide a quick way to survey a large building.

If exhibit objects could be damaged by light, cameras are available that need little background illumination. Infrared illuminators also are available to boost the efficiency of CCTV cameras where visible light levels must remain low.

Where CCTV is part of the protection system, after-hours lighting is an important consideration.

- Motion detectors can turn on lights and the VCR.
- In a large building, you may want to have central light controls, so specific areas, or the whole building, can be illuminated at once. Low voltage remote control switches are well suited to that purpose.

11. *What is the value of human presence?*

A human presence or response is a critical element in any physical security system. The mere presence of a person on the site is a deterrent. Of more importance, however, is a prompt response by a trained person when an attempt is made to breach the physical security of the site.

12. *Where can I get help?*

Refer to the following resources for additional information:

- NPS law enforcement and physical security specialists.
- Your regional/SO curator.
- The security or protection services departments in most large museums, such as the Smithsonian Institution, for advice and answers to specific questions.
- The American Society for Industrial Security's (ASIS) Standing Committee on Museum, Library, and Archive Security. Members of the Standing Committee will give advice on specific problems. Call the ASIS Headquarters at (703) 519-6200, or visit their website at <<http://www.asisonline.org>>. You can also order their publication *Suggested Guidelines in Museum Security*.

- Burke, Robert B. and Adeloje, Sam. *A Manual of Basic Museum Security*. Paris, France: International Council of Museums (ICOM), International Committee on Museum Security, 1986.
- Department of the Army. *Physical Security. Field Manual No. 19-30*. Washington, D.C.: Department of the Army, 1979.
- Fennelly, Lawrence J. (Editor). *Museum, Archive, and Library Security*. Boston: Butterworths, 1983.

G. Electronic Security Systems

Electronic systems (e.g., CCTV, alarm systems) are only extensions of staff eyes and ears; they only provide information. There are four important questions you should answer before selecting an electronic security system to protect museum collections.

- What is the threat?
- How vulnerable is the collection?
- Are there restrictions on the installation?
- What should the system do?

1. *What is the threat?*

Learn as much past history as possible about thefts, acts of vandalism, accidental damage, and wear and tear on furnishings.

2. *How vulnerable is the collection?*

Go through room by room and identify museum objects that are vulnerable to theft, accidental damage, and wear and tear from visitor touching (whether purposeful or inadvertent).

3. *Are there restrictions on the installation?*

With the range of technology available, devices in period rooms do not have to be intrusive. Some security specialists argue that making detectors visible acts as a deterrent. Others make the case that visible detectors give away valuable information a thief can use to defeat the system and allow the potential burglar to spot weak points. Management has to make the final decision based on the level of the threat, the value and vulnerability of the collection, and the interpretive objectives. There is no completely right or wrong answer.

If you do use visible detectors, there are several things that can be done to minimize the information the potential thief can get while walking through the building.

- Mix visible and hidden devices. Visible detectors signal the would-be thief that there is a protection system, while the hidden devices provide back-up if the thief tries to exploit perceived weaknesses.
- Many parks leave the walk-test lights active on motion detectors. These lights are there so the installer can test the detector and measure

the area it covers. Active walk-test lights give the same information to a would-be intruder. There are two schools of thought on how you might protect a space with motion detectors: position detectors to cover areas the intruder most likely will cross (creating traps), or install enough detectors so the intruder cannot move more than 6" undetected anywhere in the space.

As an added deterrent, you can also leave walk-test lights active where there is 100% saturation coverage, although such coverage is expensive and more intrusive in a period room. Designers usually specify saturation coverage for vaults and other highly protected spaces. Where detectors create traps, the walk-test lights should be disabled. On most detectors this involves changing a switch or jumper wire inside the detector. Follow the instructions that accompany the detector. If all else fails, a piece of tape covering the light serves the same purpose.

- Damage to historic fabric
 - Be sensitive in placing security devices so as to prevent unnecessary damage and ensure that necessary damage is repairable.
 - Be aware of vertical and horizontal spaces where installers can run alarm wire.
 - Know if other work is planned that will open walls or ceilings. This may help with the placement of detectors.
 - Where physical or aesthetic considerations limit the ability to run wire, consider using wireless alarm devices so you don't have to penetrate surfaces. A combination of hard-wired and wireless devices may be optimum in many historic buildings.
- Placement of furnishings
 - The location of furniture in a room greatly influences the type and location of detectors that will be appropriate. Furniture can block a detector, making it ineffective, or, used properly, furniture can help disguise a well-placed detector.

4. *What should the system do?*

- If you install a **daytime alarm system**, is it more important to deter the act or catch the person who commits the act? If deterrence is preferred—as it normally should be—the design will include audible and visual indications that the act has triggered an alarm. If apprehension is preferred, audible and visual alarms may defeat the purpose.
- A **nighttime alarm system** has both deterrent and apprehension objectives. First, decide if a silent alarm, that summons law enforcement personnel, or a noisy one, that both summons law enforcement personnel and draws attention to the site, is the most effective.

A silent intrusion detection system is more likely to lead to catching the intruder. And, in a populated area, an intrusion detection system sounding a loud horn or turning on lights may scare the intruder away empty handed. The determining factor should be a reasonable estimate of how much time the intruder needs versus the length of time before someone notices the alarm and takes action to stop the theft. If it only takes a few minutes, then doing everything reasonable to prevent the loss must take precedence over apprehension.

- **Personal Protection Alarms** allow people working in the building the ability to summon help quickly and silently, especially where assault, robbery, or harassment is a threat. (The reception desk in an urban park headquarters building located in a high crime area is a good example.)

Personal protection alarm systems (duress or panic alarms) can use small push-button radio transmitters, worn either as a pendant around the neck or on a belt, for protection of staff members who must move around in the course of their work, or fixed position transmitters for personnel at fee collection or sales shop cash registers.

5. *What factors influence a system's design?*

- Know who the responders are, where they are located, and the resources they have.
- Know how long it will take the responders to get to the site at different times of the day. Many jurisdictions have more police on duty between 4:00 p.m. and midnight than other times, but they are busier during that period. Rural areas may have only one or two officers on duty, each covering many square miles of area.

Where response time is long, the security system must include both electronic and physical security elements to be effective. If it takes the first responder 15 minutes to get to the site after the alarm sounds, then, to prevent the thief from taking an object it must be physically impossible to remove it in less than 15 minutes:

- It must be large and heavy enough to delay removal.
- It must be located in a room or vault that will withstand a determined attack for more than 15 minutes.
- It must be in a case that can withstand attack until help arrives.
- It must be some combination of the above.

Otherwise, the alarm only indicates someone entered the building and something may be gone.

- Think about what the responders know about the site. Consider access to the site, familiarity with the physical layout, and the responder's general level of training..

- Decide what information is needed by thinking about what will be done with it. Electronic systems provide all kinds of information. The more complex the system, the more costly it is to maintain, and the more important it is to maintain it regularly. Just as you would not under design an electronic security system, do not over design it.
- Determine the system's operating parameters. Some objects on display may need 24-hour individual protection. Value, replaceability, sensitivity to controversy, ease of sale, and vulnerability to damage. Precious metals, gems, firearms, edged weapons, currency, coins, jewelry, original documents, rare books, and stamps are all candidates for 24 hour protection systems.
- Identify how you will need to change operations. You can determine which changes are necessary by considering these issues:
 - Electronic systems complicate access, even for authorized personnel.
 - Electronic systems create the need for additional staff training.
 - Someone has to manage the electronic system.
 - Those operating, managing, and maintaining sophisticated electronic systems need different skills than those using less complicated systems. An electronic system may, in some cases, require more staff.
 - It is very expensive to contract out all routine maintenance and minor repairs. If no one in the maintenance division can take care of them, money must be programmed into the budget, or someone must be trained, or both.
- Consider the following park specific issues:
 - The schedule for opening and closing the structures when staff arrive and depart, and visitor hours.
 - The procedures and staffing needed for opening and closing the structure.
 - The number and location of people on duty at any given time governs the nature of the response to daytime alarms and influences where and how to display the alarms.
 - The visitor tour path and direction, the number of persons on a tour, and the number of staff with each tour group help determine daytime alarm needs.

When all visitors are in tour groups, closely monitored by staff at all times, there may be less reason to install sophisticated alarm devices. However, when visitors wander freely through a structure,

and there are not enough staff to provide surveillance, electronic protection for objects becomes more important.

- You need to know the parts of the structure that are off-limits to visitors. Define the nature and level of access control needed in those places, and identify who is allowed in and under what circumstances. Provide information about physical access control measures, such as locks, and indicate whether to incorporate card readers, numeric keypads, or other devices into the overall alarm system.
- Study the environment. Where the components will be installed determines which technology you select. For example, if the building is reinforced concrete, or has a large amount of metal in the structure (including, perhaps, metal foil backed wall paper) then a wireless system may be a poor choice. Ambient temperature, humidity, and dust levels also are important considerations.
- Consider not only who responds, but also who monitors your system. With CCTV, for example, experience shows that someone can watch a monitor for about 30 minutes before it starts to become part of the visual background. This suggests the person assigned to monitor the system should be rotated every half hour. If not, then the system must include additional devices to identify potential threats and attract the operator's attention, such as a video motion detector.
- Observe the physical characteristics of the exhibit. For example, in a museum gallery where many people are present, color CCTV displays make it easier to distinguish and describe an individual. Where the camera is located in a little-used hallway, however, less expensive black and white monitors are usually sufficient.

6. *What are the types of intrusion detection devices?*

There is no cookbook way to design an effective intrusion detection system. Each protection problem is different, and the design of the intrusion detection system must reflect this. If not, the system will not provide effective protection, or the nuisance alarm rate will destroy confidence in it. Figure 9.5 describes commonly used intrusion detectors, how they detect, where to put them and common sources of nuisance alarms.

Each detector has strengths and weaknesses so an intrusion detection system that relies on one type has all the weaknesses of the detector selected. For example, using only contacts to protect doors, windows, and cases makes the building vulnerable if the intruder breaks the glass in a window and enters through the hole without raising the sash. Glass-break or motion detectors complement and provide back up for perimeter and case protection detectors.

TYPE	WHAT IT DETECTS	WHERE TO PUT IT	COMMON SOURCES OF NUISANCE ALARMS
Passive Infrared (PIR)	<ul style="list-style-type: none"> • Movement of an infrared heat source (in the range generated by the human body) 	<ul style="list-style-type: none"> • Best located so intruder's path of travel crosses the detection zone of the detector; least effective where intruder's path of travel is directly toward or away from the detector. • Aimed at a wall, floor or ceiling with a stable background temperature located within the design range of the detector. 	<ul style="list-style-type: none"> • Heat sources (radiant heaters, hot water pipes, heat supply grills, etc.) • Surfaces heated quickly by the sun (metal doors, large areas of glass, etc.) • Aimed into open space, no stable background within detector range (for example, aiming a detector with a 50' range into a space 75' wide). Hot air moving at the detector's outer range can cause alarms. • Temperature extremes (below 32°F or above 100°F). • Small animals, such as cats, dogs, raccoons, large rats. Birds generally are not a problem. • Large amounts of dust. • Large electric motors, air compressors that cycle on and off.
Photoelectric Beam	<ul style="list-style-type: none"> • Movement of a solid object crossing the infrared light beam. 	<ul style="list-style-type: none"> • Large open spaces • Out-door applications • Period rooms or other locations where an unobtrusive detector is desirable. The transmitter and receiver can be disguised or mounted inside a wall or other structure, although the transmitter must have a clear path to the receiver. If not hidden or disguised the intruder can step over or go under the beam. 	<ul style="list-style-type: none"> • Birds or large insects. If used outside, set the beam far enough off the ground to let small animals cross the path, or the area must be fenced to keep them out. Stacked arrays or multiple beams can compensate for this. • Accumulations of dust, although more sophisticated devices compensate for gradual changes caused by environmental conditions.
Microwave Motion Detection	<ul style="list-style-type: none"> • Changes in microwave frequency. The detector transmits and receives electromagnetic energy in the microwave range (radar). Microwaves leave the transmitter, bounce off the target back to the receiver. The detector operates on the doppler effect (the frequency of the microwave energy changes as a target gets closer to or further away from the detector). 	<ul style="list-style-type: none"> • Best located so intruder travels toward or away from the device. A target that stays exactly the same distance from the device, but moves laterally to it, may not be detected. • Can be mounted behind some solids (microwaves will penetrate 1" or more of wood. Useful where visual intrusion is a concern (place detector inside a piece of furniture, behind wainscoting, etc.) • Aimed at a solid structural feature (masonry wall, etc). 	<ul style="list-style-type: none"> • Two devices in the same room operating on the same frequency. (One detects energy radiating from the other, causing unwanted alarms. Not a problem if detectors operate on different frequencies.) • Detector aimed at an outside wall fronting on a busy street, or a thin wall with foot traffic close to the building. • Aimed at a window or glass door. (Glass is invisible to microwave.) • Aimed at objects that move under normal conditions (curtains in the path of an air supply or draft from a door or window, for example).

Figure 9.5. Types of Intrusion Detection Devices

TYPE	WHAT IT DETECTS	WHERE TO PUT IT	COMMON SOURCES OF NUISANCE ALARMS
Ultrasonic Motion Detection	<ul style="list-style-type: none"> Changes in high-frequency sound. Similar to microwave, except uses high frequency sound energy. 	<ul style="list-style-type: none"> Similar to microwave, but does not penetrate solids, including glass. 	<ul style="list-style-type: none"> Strong air movement. Aimed at object that moves under normal conditions. <p>Unwanted alarms make these devices unpopular except where used with another technology (PIR or microwave in dual technology devices). Stable when used inside vitrine cases (alarms if cover is removed or broken).</p>
Dual Technology Detectors	<ul style="list-style-type: none"> Detector combines two technologies (e.g., microwave and passive infrared or ultrasonic and passive infrared), Activation of both technologies needed for alarm. Fewer unwanted alarms when used properly. 	<ul style="list-style-type: none"> Same general considerations as other motion detectors. 	<ul style="list-style-type: none"> Environmental conditions or installation that voids one of the detection technologies (see above).
Sonic Sensors	<ul style="list-style-type: none"> Sound in the frequency range associated with movement. 	<ul style="list-style-type: none"> Quiet locations such as inside a vault. 	<ul style="list-style-type: none"> Vibration, shock, and some ambient noise conditions.
Passive Audio Sensors	<ul style="list-style-type: none"> Any sound in the protected space. 	<ul style="list-style-type: none"> Quiet locations such as inside of a vault. 	<ul style="list-style-type: none"> Ambient noise.
Contact Switches	<ul style="list-style-type: none"> Opening or closing a mechanical switch—includes magnetic door and window contacts, plunger switches, and roller or ball switches. Magnetic contacts are in two parts: a magnet mounted on a movable surface and a switch mounted on a fixed surface. Moving the magnet away from the switch causes the device to go into alarm. Properly installed, they are stable with a low failure rate. 	<ul style="list-style-type: none"> Doors, windows, hatches, etc. Exhibit cases, object protection (e.g., plunger switch under a object to detect movement of the object.) If there is a large gap between the magnet and the contact switch (e.g., the door on an historic building is warped or fits loosely), a larger magnet may stabilize the alarm. If warping at the top and bottom of the door is extreme, install contacts near the latch. Mount magnetic contacts on top or bottom of door about 6" from the latch edge. Magnetic contacts mounted on the hinge edge of the door allow the door to open enough to enter without an alarm. Use roller or ball switches for this. 	<ul style="list-style-type: none"> Flimsy doors that rattle excessively in the wind Doors that shrink or swell excessively as weather and the seasons change Wide gaps between the magnet and the contact switch caused by settling of the building Overhead doors with excess up and down movement when locked.

Figure 9.5. Types of Intrusion Detection Devices (continued)

TYPE	WHAT IT DETECTS	WHERE TO PUT IT	COMMON SOURCES OF NUISANCE ALARMS
Capacitance Motion Detection	<ul style="list-style-type: none"> The device generates a capacitance field 4-6" from the protected object. Detects any electrical conductor that enters the field. Most sound a local alarm to let the person know he or she is too close. Used to prevent touching--alarm sounds before person touches the protected object. 	<ul style="list-style-type: none"> Primarily used in museums to protect high value wall hangings or paintings from touching. Must be used with physical barriers to prevent accidentally getting too close to the protected object. 	<ul style="list-style-type: none"> Lack of physical barriers to prevent visitors from accidentally getting too close to the object. Requires frequent adjustment, and is sensitive to humidity and moisture.
Pressure Mats	<ul style="list-style-type: none"> Pressure 	<ul style="list-style-type: none"> Usually placed under a rug or carpet to detect an intruder who steps into the protected space. Period rooms with a rug or floor cloth. 	<ul style="list-style-type: none"> Lack of barriers to prevent visitors from stepping into protected area accidentally.
Vibration or Shock Detection	<ul style="list-style-type: none"> Vibration or shock 	<ul style="list-style-type: none"> Attached directly to the protected object, an exhibit platform, or the structure of an exhibit case. 	<ul style="list-style-type: none"> Vibration from a train, trucks or cars on a busy highway, or an air handler that cycles on and off. Some have adjustments to screen out ambient vibration.
Glass Break Detection	<ul style="list-style-type: none"> Frequency Discriminators: A sound detector activated by frequencies generated by breaking glass. Metallic Foil or Wire: A ribbon of lead foil or small wire that acts as an electrical path. Attaches in a pattern around the outside of a window glass. Breaking the glass breaks the electrical circuit to activate an alarm. 	<ul style="list-style-type: none"> Frequency discriminators can be concealed near the protected glass. Foil must be mounted directly to the protected glass (limiting its usefulness in historic houses with original glass). 	<ul style="list-style-type: none"> Frequency Discriminators: Clicking sounds, such as the sound of a heel tap on a tile floor, air moving through supply and return grills in the HVAC system, pipes heating and cooling, and some equipment noises. Foil: Accidental damage and damage from water, sun, and temperature changes.
Strain Sensors	<ul style="list-style-type: none"> Detects elongation of the under side of a joist, floor, or platform that occurs when weight is applied to the top surface. 	<ul style="list-style-type: none"> Underside of floors, stair treads, and other surfaces an intruder might walk over. Under surfaces supporting high value objects to detect removal of the object. The sensor adjusts for weight normally on the surface. After it adjusts, the device alarms if the weight increases or decreases. 	<ul style="list-style-type: none"> Large animals with access to the protected area.

Figure 9.5. Types of Intrusion Detection Devices (continued)

7. *What are the most common causes of a false alarm?*

There is no such thing as a false alarm. An electronic detection system alarms because something approximates the conditions that one or more of the components of the system are designed to detect.

- If a rat runs in front of a microwave detector, it should alarm. The rat's movement has all the qualities that the detector was designed to detect. The alarm may be unwanted and a nuisance, but it is not false. To stop unwanted alarms like this, either select another type of detector that will not register the movement of the rat, or get rid of the rats!
- Power-induced alarms are unwanted, but power fluctuations can mimic the conditions the system is designed to register. The fix for this problem is to clean up the power supply.

The primary cause is human error. Someone either forgets to turn the system off, turns it on or off incorrectly, or accidentally triggers the system in some other way. The solution is either educating the users better or simplifying the system. Poor system design and lack of maintenance are other causes.

8. *What can I do to reduce the number of false alarms?*

Think about the conditions the system is designed to detect and then look for those conditions or conditions that mimic them. Look for patterns in the alarm records. For example, protection staff at a park noted a passive infrared detector in a loading dock often went into alarm between 6:30 a.m. and 8:00 a.m. Examining the area showed the device was aimed at a metal roll-up door facing east. As the sun came up and heated the door, infrared radiation inside the loading dock put the device into alarm. Repositioning the device cured the problem.

9. *What are other design considerations?*

Electronic access control systems can stand alone, or they can be computer controlled. Some use cards, some use keypads, and some use both. Some can be integrated with a CCTV system. The advantages are:

- You can customize a person's access to a particular area at a particular time. High security areas can be programmed to require two authorized people before entry is granted.
- A lost card can be programmed out of the system and does not have to be recovered (unlike a lock system where a lost key requires extensive and expensive rekeying).
- The system can provide a record of who entered a space and when.

Closed circuit television (CCTV) systems can improve the efficiency of the protection staff. With CCTV one person can monitor multiple and remote locations. CCTV does not replace personnel, however; someone always has to respond to prevent losses.

Lighting is also an important consideration in the design of a CCTV system. See the discussion on lighting in Section F.

Electronic exhibit and case protection systems require technical input from someone familiar with the design of exhibit and case protection systems.

Many of the detectors discussed in Figure 9.5 are useful for protecting exhibits and cases. As with intrusion detection systems, there is no cookbook way to protect cases or exhibits.

Alarm response time is critical because exhibit and storage cases are the innermost rings of the bull's-eye. They directly house the objects we most need to protect. When the thief is inside the case or exhibit, the loss is imminent. At that point only the exhibit mounting stands between the thief and the object. If vandalism is the intent, the object will already be damaged.

Electronic system maintenance components are sensitive to heat, cold, dust, lightning, power fluctuations, power outages and mechanical damage, and must have regular routine maintenance to operate as designed.

System maintenance can be contracted out, although as a rule, standard maintenance agreements do not cover damage from electrical power problems, lightning, accidental or deliberate mechanical damage, or natural disasters. Repairs not covered by the maintenance agreement usually are made on a time and materials basis. The alternative is to train or hire in-house staff to maintain the systems.

10. *Where can I get help?*

You can obtain additional assistance from:

- Park or regional/SO protection staff.
- Your regional/SO curator.
- The security or protection services departments in most large museums, such as the Smithsonian Institution, for advice and answers to specific questions.
- The American Society for Industrial Security's (ASIS) Standing Committee on Museum, Library, and Archive Security. Members of the Standing Committee will give advice on specific problems. Call ASIS headquarters at (703) 519-6200, or visit their website at <<http://www.asisonline.org>>. You can also order their publication *Suggested Guidelines in Museum Security*.
- Barnard, Robert L. *Intrusion Detection Systems: Principles of Operation and Application* 2nd rev. ed. Boston: Butterworths, 1988.

H. Protecting Collections in Transit

Museum objects are at greatest risk when in transit from one place to another. Whether in the custody of a courier, a bonded mover, or the U.S. mail, the act of transporting objects exposes them to risks not encountered in the park. Deciding how to transport a museum object safely, how much protection to provide, and how much it will cost, demands a rigorous analysis of the risk. Consider the following issues before consigning museum objects to a mover.

1. *What are the object's characteristics?*

Consider the object's value (monetary, historic significance), its vulnerability to theft or damage, and its physical characteristics, that limit the appropriate means of transportation such as size, weight, and composition.

2. *What means of transportation should I select?*

Objects that are especially vulnerable to theft or damage or that have significant value should be carried by the most secure means possible. That may mean a courier, a contract carrier, or both.

The most significant threat to an object in transit is a transportation accident. Like a fire, an accident involving the transport vehicle can destroy everything in it. The prospective transporter's safety record should be a significant factor in selecting a carrier.

3. *How should objects be handled in transit?*

Discuss special handling considerations with the transporter. For example, mechanical lifting devices, such as forklifts, should not be used for most categories of museum objects. Spell out these requirements to the transporter in advance.

4. *Is chain of custody important?*

Yes! A courier is the optimum way to handle chain of custody. However, except for very important objects, a courier may not be practical because of the cost. Nevertheless, it is vital to define how accountability transfers from one person or organization to another.

- Establish inventory procedures that do not require the objects to be unpacked when custody changes.
- When the objects are transported by a bonded mover, the contract should state that the driver will not leave the truck unattended for breaks, meals, or any other reasons.

5. *What about intermediate stops?*

Long distance movers often route objects from one place to another by way of central collection points, much as an airline routes passengers to one city via a hub in another. Intermediate loading and unloading of museum objects increases the risk of damage significantly.

If possible, museum objects should be moved directly from point A to point B with no intermediate unloading and reloading. If the values do not justify the cost of direct, non-stop routing, try to keep intermediate stops to a minimum.

If objects are placed into temporary storage along the way, the warehouse should be bonded, and the park should review the warehouse's security procedures.

6. *What about delivery time?*

When the objects reach their destination, someone should be on site to receive them. Specify in the contract that the mover will schedule the arrival of the van at a time when the receiving facility is open or staffed.

7. *Where can I get help?*

- The Registrar's Committee and the Security Committee of the American Association of Museums (AAM) provide specialized publications and referrals. Call the AAM in Washington, D.C. (202-289-1818) for a contact.

I. Reporting and Recovering Stolen Museum Objects

Time is critical after a theft because after only a few hours the likelihood of recovery for most museum objects is very small. Success depends on:

- detecting the loss quickly
- notifying law enforcement agencies rapidly
- providing a detailed description of the objects and, if possible, a photograph

1. *What should I do if I suspect a theft?*

Before calling the police, make sure that a staff member has not moved the object to another location within the park. If you cannot locate the missing object within a reasonable time, call the park law enforcement specialist and the police.

- Secure the area and do not permit anyone to enter.
- Determine exactly what is missing, but do not handle or move anything, or allow anyone else to do so. Consider everything in the area of the theft as potential evidence.
- Locate the following records:
 - Museum Catalog Record (Form 10-254) for each missing object. Make photocopies for use during the investigation.
 - A clear photograph of the missing objects.
- The park's law enforcement officer must complete a Case Incident Record (Form 10-343), with a copy of each relevant museum catalog record attached to the report.

See the NPS MH-II, Chapter 4, Inventory and Other Special Instructions, for guidance on reporting the loss of museum objects.

2. *How do I report a theft to outside agencies?*

Theft of museum objects and library, archival and manuscript materials is a serious international problem, and only 10 to 15 percent of stolen museum objects are recovered. This is because it is difficult to alert law enforcement agencies outside the area where the theft occurred about the theft. The problem is especially acute when the thief takes the stolen object over a

state or international boundary, a common occurrence with stolen museum objects.

You should notify other appropriate agencies and offices as soon as possible after notifying local law enforcement authorities and the NPS law enforcement specialist. It is vital to report all losses, because the more widely a loss is reported, the better the chance of recovery.

Depending on your arrangements with the local police, they may be the conduit for reporting crimes to the Federal Bureau of Investigation (FBI) and to the International Police Organization (INTERPOL). See NPS *MH-II*, Chapter 4, Inventory and Other Special Instructions, Section III, for a list of agencies to which you can report a theft.

3. *How should I handle the news media after a theft?*

Dealing successfully with the news media can help limit the public relations impact of a theft.

- Detail **one** person as the media spokesperson and coordinate **all** communication with the news media through that person.
- Do not discuss details of the theft with the public, news media, or other employees.
- Do not speculate about what happened, what was stolen, or the value of the missing objects.
- Prepare a statement for the news media with general information about the incident, and release it as soon as practical.

J. Museum Collection Records

Museum records are as valuable as any object in the collection and should be just as well protected.

1. *Why are the records important?*

Records, catalogs, and photographs of the park's museum collection are vital for security of the collection. For example, stolen objects are more likely to be recovered if they have been cataloged and if a full description and even a photograph of the object is available for law enforcement agencies.

2. *When should I use the camera?*

Photographs are better for describing and identifying objects than written records.

- Photograph the museum collection, or at least the more valuable or sensitive objects.
- Photograph exhibits, both as a record of the exhibit and as a quick way to inventory objects on exhibit when opening and closing for the day. Consider keeping photographs in a three ring binder as a quick reference for interpreters. Some museums and historic sites keep catalog information about specific objects in the binder as well to help interpreters answer visitor questions about the history of the objects on

exhibit. See *MH-II*, Chapter 3: Cataloging, for procedures on cataloging, and Appendix K: Photography, for guidance on photographing museum objects.

3. *Should I review my museum records protection program?*

Yes. Records are vulnerable to a wide range of threats--human error, fire, theft, mildew, mold, pests, paper deterioration, water damage, disasters and electronic media deterioration--and require constant attention.

- Keep duplicates of all museum property records in a secure location off-site. Avoid a location that will be affected by an area-wide natural disaster, such as an earthquake, that would affect both the park and the off-site location.
- Restrict access. Catalog and accession records should not be accessible to visitors, researchers, or non-museum employees except under the close supervision of the curatorial staff. Theft of an object and its associated museum records makes it extremely difficult to trace the object or to prove its ownership.
- Check environmental conditions and make sure there is an active pest management program.
- Keep records away from pipes and out of basements or flood plains. Use water or leak detection alarms where water damage is a potential threat.
- Make sure records are included in disaster and recovery plans.
- Train personnel in proper record maintenance techniques, and check work for accuracy.
- Keep important records on high quality paper (high rag content with alkaline deterioration buffer).
- Make sure electronic media are backed-up, stored properly, and access is controlled.
- Store paper records in a locking, approved UL-Rated Class C or D, as appropriate) insulated filing cabinet.

4. *Where can I get help?*

Consult the following resources for additional information:

- For detailed descriptions and applications guidelines, see the *CRM Bulletin Supplement* by John E. Hunter cited in Section K.
- Your park's fire safety officer, a local fire marshal or an NPS archivist or collection manager.
- *NPS Tools of the Trade* for sources of approved insulated files.
- *MH-II*, Chapter 2: Accessioning, for guidance on protecting museum records.

K. World Wide Web Resources

College and Research Library News (C&RL News): <<http://www.rbms.ne.edu/>> Includes:

ACRL Standards for Ethical Conduct for Rare Book, Manuscript, and Special Collections Libraries and Librarians, with Guidelines for Institutional Practice in Support of the Standards.
ACRL/SAA Joint Statement on Access to Original Research Materials.
ACRL Guidelines for the Security of Rare Books, Manuscripts, and Other Special Collections.

Museum Security: <<http://museum-security.org/>>

Fire Safety: <<http://www.nfpa.org/>>

ExLibris (list serve). Send blank message without signature with the following in the subject line:
subscribe ExLibris Your Name to <listproc@library.berkeley.edu>

Archives (list serve). Send blank message without signature with the following in the subject line:
subscribe Archives Your Name to <listserv@miamiu.acs.muohio.edu>

L. Selected Bibliography

Advisory Council on Historic Preservation. *Fire Safety Retrofitting in Historic Buildings*. Washington, D.C.: Advisory Council on Historic Preservation and the General Services Administration, 1989.

ASIS Standing Committee on Museum, Library, and Archive Security. *Suggested Guidelines in Museum Security*. Arlington, Va: American Society for Industrial Security (ASIS), 1997.

Barnard, Robert L. *Intrusion Detection Systems: Principles of Operation and Application* 2nd rev. ed. Boston: Butterworths, 1988.

Brady, Eileen E. *Library/Archive/Museum Security: A Bibliography*, 5th rev. ed. Moscow, ID: Catula Pinguis Press, 1995.

Fay, John Jay, ed. *Encyclopedia of Security Management: Techniques and Technology*. Boston: Butterworth-Heinmann, 1993.

Fennelly, Lawrence J. *Handbook of Loss Prevention and Crime Prevention*, 3rd rev. ed. Boston: Butterworths, 1996.

_____. *Museum, Archive, and Library Security*. Boston: Butterworths, 1983.

Howie, F. M. P. *Safety in Museums and Galleries*. Boston: Butterworths, 1987.

Hunter, John E. "Filing Cabinets and Safes for Protection of Paper Records, Computer Media, and Photographic Records from Fire Damage." *Cultural Resources Management Bulletin Supplement*, Volume 16, Number 5. Washington, D.C.: National Park Service, 1993.

Hunter, John E. "Fabricating Secure Hangers for Framed Works of Art." *Conserve O Gram* 2/7. Washington, DC: National Park Service, 1994.

Inland Marine Underwriters Association and Society of American Archivists. *Libraries and Archives: An Overview of Risk and Loss Prevention*. New York: Inland Marine Underwriters Association, 1994.

Layne, Stevan P. *The Cultural Property Protection Manual*. Denver: Layne Consultants International, 2002.

Liston, David (Editor). *Museum Security and Protection, A Handbook for Cultural Heritage Institutions*. New York: Routledge, Inc., 1993.

National Fire Code Standards. Quincy, MA: National Fire Protection Association (NFPA)

- NFPA 1: *Fire Prevention Code*, 2000
- NFPA 10: *Portable Fire Extinguishers*, 1998
- NFPA 13: *Installation of Sprinkler Systems*, 1999
- NFPA 25: *Inspection, Testing and Maintenance of Water-Based Fire Protection Systems*, 1998
- NFPA 70: *National Electrical Code*, 1998
- NFPA 72: *National Fire Alarm Code*, 1999
- NFPA 110: *Emergency and Standby Power Systems*, 1993
- NFPA 909: *Protection of Cultural Resources*, 2001
- NFPA 914: *Code for Fire Protection of Historic Structures*, 2001

Sable, Martin H. "The Protection of the Library and Archive: An International Bibliography." *Library and Archival Security*, (Summer/Fall), 5:2/3:1-183, 1983.

Strassberg, Richard. "Library and Archives Security." In *Preservation: Issues and Planning*. Edited by Paul N. Banks and Roberta Pilette. Chicago: American Library Association, 2000.

Wilson, J. Andrew. "Fire Fighters--An Automatic Fire Suppression System is Among Your Museum's Best and Safest Forms of Insurance." *Museum News* (November/December), 68:6:68-72, Washington, D. C.: American Association of Museums, 1989.

M. Endnotes

1. NFPA 909: *Code for the Protection of Cultural Resources*. Quincy, MA: National Fire Protection Association, 2001, p.909-31, Table A.8.1, "Causes of Structural Fires in Museums or Art Galleries (1980-1997 Annual Averages)."
2. NFPA 909: *Code for the Protection of Cultural Resources*. Quincy, MA: National Fire Protection Association, 2001, Appendix A, A-8.1, p909-31.

CHAPTER 10: EMERGENCY PLANNING

A. Overview

Museum and archival collections inevitably deteriorate over time. You, as a member of the museum staff, minimize this collection deterioration through preventive conservation such as proper housing and handling. Although you are unlikely to frequently encounter fires, floods, volcanic eruptions, and similar events, *ultimately no park is immune from emergencies*. Once neglected or handled inappropriately, an emergency goes out of control and becomes a disaster.

Your goals are to:

- 1. Identify, anticipate, and avoid preventable emergencies.*
- 2. Mitigate damage when an emergency occurs so that disaster is avoided or minimized.*
- 3. Recover from disasters as quickly and professionally as possible so that no human life is lost and minimal collection damage and loss occurs.*

Disaster is often sudden and unpredictable. Catastrophes like the Florence, Italy, flood; the Mount St. Helens eruption; and the North Ridge, California earthquake are the stuff of newspaper headlines and curatorial nightmares. This chapter explains how to:

- *assign responsibility* for emergency planning, management, and response
- *gather essential planning tools* such as those described in the bibliography and Appendix G
- *understand and manage the various generic types of risk that exist for museum collections*, including how to prepare for them, manage risks during an emergency, and survive them
- *analyze your park's own particular risk level* for the various types of hazards (potential natural and cultural threat factors) and vulnerabilities (likelihood of sustaining damage)
- *begin salvage* during the first 24 hours following an emergency
- *prepare a Museum Collection Emergency Operation Plan (MCEOP) as part of the park's Emergency Operations Plan (EOP)* to cover the protection and prioritized salvage of the park's museum and archival collections based upon all the likely contingencies that form part of the park's risk
- *stockpile essential emergency response equipment and supplies*

- *train staff* in emergency planning, management, and response activities
- *test, evaluate, and update your MCEOP*

Advance planning is the key to effective emergency response and the recovery of museum and archival collections. Your planning today will control how effectively damage is mitigated in tomorrow's emergency. No park has the equipment, supplies, and expertise necessary to cope professionally with a significant emergency without a good MCEOP. Strive for thoroughness, clarity, and practicality when preparing your plan. Keep your plan simple, flexible, and based upon existing museum routines so as to make it easy to implement.

1. *Who can help me with emergency planning?*

Emergency planning involves:

- *coordinating with the park's EOP coordinator* to ensure that the museum collections will be integrated into the park's EOP and with local emergency services agencies to identify sources of assistance. Work with the EOP coordinator to identify who will be responsible for managing and updating the museum component of the plan.
- *working with the Regional Curator and others* such as the Regional Office's Division of Ranger Activities and your regional/Support Office (SO) curator to identify individuals who should be involved in the museum component of the plan.
- *working with contract personnel* as necessary. Contractors can help you regularly reexamine assumptions about risks to collections so you can update the plan and training. See Section C and Appendix G: Museum Collections Protection.

2. *Why should I plan for emergencies?*

There are many good reasons to plan for emergencies, including:

- saving lives
- preserving collections
- saving time and resources

Practically speaking, when you are in the midst of responding to emergencies you are probably not thinking clearly. During an emergency is not the time to conduct research on how to salvage collections. You need the knowledge before the emergency, to reduce the risk of human injury and resource damage and loss.

3. *What authorities and federal guidance exist on emergency planning and disaster prevention?*

Consult the following:

- 36 CFR 1236, Vital Records During an Emergency Executive Order
- 44 CFR 101-2, Occupant Emergency Plan

- 12656, Assignment of National Security and Emergency Preparedness Responsibilities, November 18, 1988
- Executive Order 12148, *Federal Emergency Management*, July 20, 1979
- Federal Preparedness Circular 61, Emergency Succession to Key Positions of the Federal Departments and Agencies
- Federal Preparedness Circular 62, Predelegation of Emergency Authorities
- Federal Preparedness Circular 64, Continuity of the Executive Branch of the Federal Government at the Regional level during National Emergencies
- *Federal Response Plan* (Federal Emergency Management Agency)
- Federal Response Planning Guidance FRPG 01-94, *Continuity of Operations*, December 4, 1994

B. Museum Collections Hazards, Vulnerabilities, and Disaster Prevention

Museum collections risk is composed of two key elements:

- **hazards**, which are the natural factors (such as storms, fire, and flood), your park's landscape and location risk factors (proximity to a tidal river or coast, volcano, or placement in a valley or near a nuclear reactor), and social factors (such as civil unrest, terrorism, and vandalism) that threaten museum collections
- **vulnerabilities**, which is the likelihood that your collection will sustain damage, due to the:
 - composition of the park museum collection (such as ceramics, glass, and friable media)
 - structures housing your materials (such as older wooden structures or flat roofed masonry structures)
 - staff-training level (explicit or textbook-type knowledge), hands-on experience-level (implicit knowledge), and state of preparedness

Your job is to understand the hazards that afflict your region, the vulnerabilities of your structure and collection, and therefore the risks you must manage. Don't forget materials in exhibition areas, research rooms, workspaces, and separate on-site or off-site structures when planning for emergencies. Park records, particularly museum records, also must be salvaged immediately or your ability to use your collections effectively in the future will be compromised. This chapter serves as an introduction to the

various hazards, vulnerabilities, and risks of museum collections. For more information, go to the sources listed in the bibliography.

1. *What kinds of emergencies exist?*

Emergencies may take many forms, including civil unrest, earthquakes, explosions, fire, flood, hazardous materials accidents, storms, structural collapse, terrorism, transportation accidents, and utility failures. They can cause damage to museum collections from bacteria, chemical change, heat, physical damage due to movement (called kinetic damage throughout this chapter), soot, water, and many other agents.

2. *What do I need to know about fire hazards?*

Fire is the most serious single threat to all park museum collections. It may lead to loss of life, loss of collections, and loss of building structural integrity—causing great physical damage to the unburned collections. During fire suppression, water, chemical, and physical damage may all occur and mold may later result. Fire hazards vary by region, with forested areas and dry plains being at particular risk of wildfires.

Fire vulnerabilities: The museum materials most vulnerable to fire are:

- botanical collections
- black powder weaponry and similar weapons and ordnance
- nitrate (nitrate) film, including negatives, motion picture film, and X-rays (***Note:*** These are particularly dangerous if the nitrate exists in quantities greater than 35 pounds.)
- paper-based materials, including artwork, documents, and museum documentation
- plastics, particularly those with antioxidants, dyes, toxic fire retardants, and other additives (dioxin, lead, and antimony), for example, vinyl chloride plastics
- specimens in alcohol and formaldehyde
- textiles
- vehicles, motors, and equipment containing oil and gasoline
- wooden objects, particularly older wooden furniture

Classic fire damage includes:

- consumption and loss of materials, particularly organic materials
- embrittlement of most organic materials
- explosions due to nitrate fires, leading to structural collapse and collection loss
- heat and smoke from fire causing accelerated aging of materials not consumed by the fire

- loss or damage of museum records, park records, and archives and manuscript collections
- melting
- mold, insect, and vermin outbreaks in the water damaged materials following fire fighting
- oxidation of metals
- fading, scorching, charring, staining, or accelerated aging of wood, paper, and textiles
- subsidiary water damage due to fire suppression (See Water damage and Floods below.)

Fire prevention: To stop fires, you need to stop ignition sources, remove potential fuel—particularly fuel that can self-ignite such as nitrate film—and maintain a proper environment that isolates museum storage, work, exhibit, and research room spaces from other spaces that may not be as well controlled. Don't allow smoking in the museum building. Allow cooking in the museum building only when precautions are taken, such as the use of fire-resistant surfaces and evening shut-down procedures that ensure heat sources are turned off. A good fire alarm, fire extinguishers, heat and smoke detectors, and a fire suppression system, including sprinklers, are also helpful. Select fire extinguishers based on the type of collections you have and the chemicals being stored in the museum building. For guidance, see *MH-I*, Chapter 9: Museum Collections Security and Fire Protection.

Maintaining good housekeeping, preventing smoking, placing highly flammable materials such as nitrate off-site, maintaining electrical systems to standards, and removing trash often will be the most important steps in preventing fires.

Museum staff should be aware of how the alarm systems, fire extinguishers, sprinklers, and other systems work. Occupational Safety and Health Administration (OSHA) and the Code of Federal Regulations (CFR 1910.157[g][2]) mandate that all staff receive training in fire extinguisher use annually. The museum building must have two usable escape routes from all areas—whether exhibit, storage, work, or reference space. All exits must be clearly visible and labeled from all locations and points-of-view. Federal law (29 CFR 1910.36[c][2]) requires that all exits, fire doors, panic bars and bolts, fire protection, and fire detection alarm systems be fully operative while any workers are in the building. If a fire system is damaged, the MCEOP should contain information on how to contact the firm for repair work. See *MH-I*, Appendix F: Collections Management Checklists, Checklist for Preservation and Protection of Museum Collections (Checklist), Questions 1-12 under Fire Protection.

Choose fire-resistant furniture, equipment (such as UL listed appliances), and carpeting or ceramic tiles. Store museum records in fireproof cabinets. For shelved items, keep a full two feet of space between the top of the shelving unit and the ceiling to avoid blocking sprinklers and fire fighting activities. Don't store collections near vents or flammable chemicals. Keep only small, carefully labeled quantities of flammable chemicals in appropriate fire-rated storage cabinets outside of museum storage areas. Provide up-to-date OSHA surveys of the chemicals or toxic collections materials to local fire fighters and emergency workers, and include them in your MCEOP. Hazardous materials (HAZMAT) storage spaces should be labeled with the appropriate OSHA warning label. See Appendix F: Collections Management Checklists, Checklist for Preservation and Protection of Museum Collections (Checklist), Fire Protection, Question 3.

Check vents of all equipment, including computers, electrical equipment, photocopiers, and similar devices to ensure that they are not obstructed. Avoid using carpeting and map case interior dust covers that contain polyvinyl chloride (PVC). Check all appliance cords regularly and unplug them at night. Replace fluorescent light bulb ballasts—particularly those over lamps that are older than 15 years—with thermally protected Class P ballasts. Keep all brush, vegetation, and trash away from your buildings. Prohibit smoking in your buildings. Keep all walkways and aisles free to facilitate fire fighting and evacuation. **Keep exits unobstructed.**

Fire survival: If you are present during a fire, activate the fire alarm immediately. During evacuation keep close to the ground. If smoke is bad, place a wet cloth over your face. Don't open windows. Check the elevator for trapped individuals. Help disabled or injured people evacuate safely without using elevators. As you evacuate, close all doors behind you. If possible, take the visitor log and your MCEOP with you to help you account for everyone in the building. Call the fire department and park fire protection staff (a ranger, park police, or maintenance) immediately.

Your MCEOP should indicate whom to contact and list their numbers (telephone, fax, beeper) and e-mail addresses. Provide the fire fighters with your MCEOP building plans and visitor log to help them in their efforts. Check to ensure all staff and visitors have departed the building. Move to a safe distance from the affected area. Try to determine if everyone has safely evacuated the building. Alert professional rescue personnel about any missing or trapped individuals and their probable location.

Never allow a fire to get between you and the door. If the fire is very small and you have time before departing with no risk to yourself, disconnect electrical equipment. Shut down the air intake system and HVAC. Place plastic sheeting over collections. Use a handheld fire extinguisher on a small non-toxic (not plastic or nitrate burning) fire, as long as you have the appropriate type of extinguisher and have been trained in its use.

Never jeopardize your safety by trying to put out a nitrate or plastics fire. Be aware of the extreme danger posed by the off-gassing of burning materials, such as nitrate and PVC. Stay away from soot and smoke, as it may be carcinogenic. If plastic or nitrate materials are in museum storage, evacuate as fast as possible during a fire. See *MH-I*, Chapter 9: Museum Collections Security and Fire Protection, for further guidance.

Before attempting to salvage museum collections, maintenance and fire staff must determine if the space is safe to enter. Once the fire is out and the structure has been stabilized for access, the composition of the soot should be determined to ensure that no carcinogens or toxic substances, such as lead, polycyclic aromatic hydrocarbons (PAH), polychlorinated biphenyls (PCBs), hazardous residues, or lethal molds or bacteria are present. Museum staff may be expected to take samples of substances with cotton swabs, scotch tape, or agar slides for immediate delivery to the testing lab for toxicity tests.

If requested to take samples of mold or hazardous substances work with the park's hazardous materials coordinator. Wear protective clothing (nitrile gloves and a smock) and an appropriately rated breathing apparatus that has been fitted to you. The MCEOP should indicate the location of testing laboratories that can identify whether the materials encountered after the fire are potentially toxic, such as P&K Micro, Unit L, 19050 Old Cuthbert Rd, Cherry Hill, NH 08034 (Tel: 609-427-4044). If large quantities of toxic substances are found in the soot or other residues, a professional abatement team may need to be hired.

After determining that the space is safe to enter and no safety hazards exist for salvage, follow salvage procedures as described in the National Task Force on Emergency Response *Safeguarding Our Cultural Heritage, Emergency Response and Salvage Wheel* and similar sources listed in the bibliography and Figure 10.13, First 48 Hours Emergency Response Checklist. If you plan to use museum personnel in response to fire emergencies, read OSHA, Emergency Plans and Fire Prevention (1910.151, 1926.50). See *MH-I*, Chapter 9: Museum Collections Security and Fire Protection, for additional guidance. Also see the U.S. Fire Administration Website at <<http://www.usfa.fema.gov/>>.

3. *What do I need to know about water damage and floods?*

Water damage is perhaps the second most common type of museum collections damage. Floods are the most widespread form of natural disaster after fire. Floods and flash floods occur in all 50 states according to the Federal Emergency Management Agency (FEMA). Since 1900 over 10,000 people have died in flooding in the U.S. Dam failures are the most dangerous form of flood.

Water damage is often the result of fire-fighting activities, storms, and structural damage, but may also be due to flash floods; floor drainage back-ups; leaking HVAC systems, pipes, roofs, and skylights; seepage and slow-rising floods; and tidal waves. Loss of life is always the greatest risk for floods.

Flood and water damage vulnerabilities: The materials most vulnerable to water damage are:

- archival materials, such as architectural drawings, plans, and blueprints; coated paper books and documents; parchment and vellum documents; documents on heavily sized paper; documents with water soluble media, such as some ballpoint or fiber tip pen ink or friable media such as charcoal or graphite; and historic photographs and film, including nitrate

- artworks, such as chalk, charcoal, collages, conte crayon, gouache, montages, paintings (paintings on canvas or panels), polychrome sculpture, and watercolors
- bone and ivory, which are hygroscopic—particularly thin sections, which warp easily
- basket and other fibrous materials with applied paint or decoration or repairs
- furniture/wood with applied gilt, fine veneer, inlays, lacquer, or attached ironwork
- furs, leather, and skin—particularly under tension (such as drums) or with applied paint—including parchment and vellum and other alum tawed leathers
- glass and ceramics with mends or that are heavily adulterated with non-silica materials
- metal objects made of bronze, brass, copper, iron, and steel
- natural history specimens, particularly extinct or endangered species or type specimens, water sensitive geological specimens (particularly shale), and paleontological specimens
- previously moldy items
- textiles, particularly thinly woven materials
- unfired clay

Classic water damage includes:

- adhesion of art, book, paper, and photographic items to other objects of organic materials
- bleeding of color from one object to another
- corrosion and rusting of metals
- erosion of stone or masonry
- finish loss on art works, photographs, textiles, and wood
- lifting of veneers on furniture
- loss or damage to museum records, park records, and museum archives and manuscript collections
- loss of dimensional stability of paper, textiles, and wood

- mineral deposits on ceramics, metal, meteorites, minerals, and stone
- molding and rotting of animal and botanical specimens, books, furniture, paper, parchment, photographs, textiles, and vellum
- pigment and dye loss on artworks, books, paper, photographs, textiles
- ripping or splitting of animal skins, paper, photographs, and fragile textiles
- separation of emulsion layers on photographs
- splitting of skins and of leather on bound volumes
- staining and deposition of contaminants on bone, ivory, paper, shell, and textiles
- structural integrity loss for paper, plaster objects, and textiles
- swelling and pressure damage that cracks or destroys nearby objects
- warpage of board, paper, thin sections, and wood
- weakening of fibers in paper, textiles, and some wood

Flood and water damage prevention: To stop floods and water damage:

- locate your collections far from dams and flood plains
- locate collections in buildings with good structural seals (including a sound and sealed roof, windows, and basements)
- keep all storage equipment at least 4 inches off the floor, preferably 6 inches off the floor
- use only spaces that will not flood if pipes break or drains back up
- See Appendix F: Collections Management Checklists, Checklist for Preservation and Protection of Museum Collections (Checklist), Museum Collections Storage, Questions 4, 5, 7, 9, and 20.

Be aware of whether your building is located on an underground stream, a swamp, or other water source or near a tidal river or coastline area. Find out if you live in a flood-prone area from your local emergency management office or Red Cross chapter. FEMA offices are listed on the FEMA Website at <http://www.fema.gov/>. The National Oceanic and Atmospheric Administration (NOAA) Website at <http://iwin.nws.noaa.gov/iwin/nationalwarnings.html> also contains excellent flash flood and flood warnings. Know the area flood stage water table level so that you can avoid storing items below this level, thus placing them at risk.

Avoid using spaces with overhead pipes, whether for water, waste, steam, fuel, or other liquid. See Appendix F: Collections Management Checklists, Checklist for Preservation and Protection of Museum Collections, Museum Collections Storage, Questions 5 and 9. Don't store materials in particularly vulnerable spaces, such as attics or basements. Ensure that all drainage and water removal systems are functioning well. Have check valves installed in building sewer traps to prevent floodwaters from backing up in sewer drains. Know where your water and utility shut-off valves are and how to operate them. Work with park maintenance to ensure they keep your building in excellent repair, regularly checking and testing foundations, walls, windows, roofs, door seals, piping, sprinkler systems, gutters, and other structural components. In particular check to ensure that the building is firmly attached to the foundation. Work with park landscapers to ensure that the landscape drains away from the buildings.

Chose storage equipment and supplies that will not cause additional damage in case of flooding. Avoid using wooden storage equipment as it:

- floats (*Note:* Also avoid metal cases with sealed air spaces that promote floating.)
- feeds insects
- may swell and crush materials housed inside
- drains poorly, holding water
- weighs a great deal when wet, potentially leading to excessive floor loading and structural collapse

Be aware of how different decorative materials and storage furniture may hold water and humidity when designing a museum storage space. For example, wallpaper, wood furniture, and carpeting hold humidity and water, while paint, metal furniture, and tile don't. When decorating your structure, use tiles, metal storage furniture, and paint, rather than wallpaper, wooden furniture, and carpeting. Avoid using acidic cardboard housing as it may stain paper and textiles if wet. Avoid using water-soluble markers on file labels and boxes, as they may wash off. Avoid using staples and metal clips as they may rust; use plastic clips instead. Select polyethylene storage boxes, where possible, as they won't collapse spilling contents if wet. Boxes with several small vents in their bottoms to allow water to run out are ideal. Poke several small drainage holes (<3 inches) in the empty boxes.

Flood watches and warnings: Know the difference between a flood watch and a flood warning. A watch is advance notice, first announced when a threat is noticed—often up to 36 hours before the event. A warning tells you it is about to happen within the next 24 hours.

Flood watch: If you are in the museum when a flood watch is announced, listen to local emergency broadcast system radio and/or a National Weather Service (weather band) radio at 162.475 MHz-FM. Ask local disaster planning experts for their predictions. Check the

Floodcast Website at <<http://www.earthsat.com/flood/floodcast.html>> and the NOAA Website at <<http://iwin.nws.noaa.gov/iwin/nationalwarnings.html>> for predictions of areas that will flood or experience flash floods or severe thunderstorms within 24 hours. Alert the MCEOP team that they are on stand-by status. Listen for alarms and updates. Listen for emergency alarm signals. To find the other six frequencies and 530 transmitters NOAA Weather Radio uses, go to <<http://www.noaa.gov/nwr>>.

As you wait for updates, unplug all non-essential electrical equipment and secure the building. Check battery-powered equipment, alternative power and communications systems, and emergency supplies. Ensure that batteries on water alarms are fresh and in place. Place water alarms near all collection storage areas to provide you with early warnings in case of roof or window leaks or backed up drains.

Fill evacuation vehicle gas tanks. Collect clean water in jugs for clean-up activities. Secure all loose objects outside, preferably by bringing them into the building. Tape windows and then pad them with bubble wrap before closing the storm shutters. If you lack storm shutters, tape windows. Use additional tape to attach plastic sheeting over the entire window well area, attaching the sheeting to the surrounding wall to provide some additional insulation and a humidity barrier. Disconnect non-essential electrical equipment. Back-up all computer files. Move unnecessary vehicles to high ground. If time allows, prepare to evacuate collections to an alternate storage location on high ground using designated vehicles as described in the MCEOP. Be prepared to drive significantly inland to get away from washed out bridges and coastal flooding. Notify authorities of any safety problems along the route.

- ***Flood warning:*** Evacuate and close the museum. Check to ensure that everyone has left safely. Mobilize the MCEOP team. Turn refrigerators and cold storage units to the coldest settings and tape them shut as early as possible to give them some residual cold to carry them through the crisis. Move designated high-risk materials, key documentation, and one copy of your MCEOP to the upper floors of the storage structure as indicated by the museum MCEOP. If there is no time to move the rest of the collection to the upper floor, move all easily movable collection items off the floor to the highest-level storage space available within the room. Place plastic sheeting over all vulnerable collections and tape in place if necessary.

Use dehumidifiers and sump pumps as necessary in the fight to prevent water damage. Place heavy screens over floor drains to keep small items from washing away. Lock all cabinets and move equipment away from windows and out of basements. Secure non-movable items. Gather emergency supplies. Just before you leave, shut down all utilities, turn off electricity at the building's main circuit breaker, unplug all electrical equipment on lower floors, seal all doors and windows, and secure the building.

Flood survival: If you are in the museum when a flood occurs, stay in the building and go to the top floor. Contact authorities by cellular phone to alert them to your situation and request rescue. Be extremely cautious around

electrical appliances and outlets. If necessary go onto the roof as long as no thunderstorm is in progress. If time allows, take a copy of the MCEOP, protective clothing, a bright rain poncho, and a colorful blanket with you to help rescue personnel locate you.

Don't try to walk or drive through water once the flood has started. Even six inches of rapidly moving floodwaters can sweep you off your feet. If you are caught outdoors or in a car, drive to high ground. Don't stay with a stalled car in rapidly rising water. Cars can be swept away by just two feet of moving water. Flash floods can tear down trees and destroy buildings and bridges.

Don't return to the building after evacuation until it is judged safe by the individuals designated in the MCEOP, usually your maintenance liaison. The maintenance liaison may need to check the safety of floors, walls, and stairways, as well as checking to ensure that the building meets federal codes and OSHA requirements. See Section D.5. When re-entering the building, watch for broken or leaking gas lines, flooded electrical circuits, submerged furnaces and appliances, flammable or explosive materials that entered the building as a liquid, contaminants that are health hazards (gas, biological waste), and biological problems, including vermin, snakes, mold, and similar problems.

Wear nitrile gloves and use sticks or shovels when poking through debris. Working in water cooler than 75 °F (24 °C) can result in hypothermia, so avoid working alone or without heavy clothing and rubber boots. If working near floodwaters, wear a life vest.

After the flood, be prepared to remove water, commercially dehumidify the building, air dry and/or wrap and freeze designated collections in priority order according to the MCEOP. Collection removal work will have to be done speedily and in priority order, for many items must be salvaged within 48 hours to prevent significant deterioration.

Pump no more than a third of the water out each day to avoid structural collapse and allow the building to settle gradually. Be cautious when working with gas or diesel-powered pumps as they often give off carbon monoxide, and can't be operated indoors without a significant risk of suffocation.

For help, see the First 48 Hours Emergency Response Checklist (Figure 10.14) and the National Task Force on Emergency Response: *Safeguarding Our Cultural Heritage, Emergency Response and Salvage Wheel* and other sources listed in the references for guidance. Also see the Websites under ***Flood watch*** and the National Institute for Occupational Safety and Health (NIOSH) Website for warnings of hazards of flood cleanup work at<<http://www.cdc.gov/niosh/flood.html>>.

4. *What do I need to know about storms?*

Storms are perhaps the most varied form of emergency, as they include blizzards, electrical storms, hail, hurricanes, sleet, tornadoes, and other wind and winter storms. On average, the U.S. gets 10,000 thunderstorms, 1,000 tornadoes, and about 10 tropical storms annually, 2 of which develop into major hurricanes. Use the NOAA Website at <http://iwin.nws.noaa.gov/iwin/nationalwarnings.html> and the Earth Watch Weather on Demand Website at <http://www.earthwatch.com/STORMWATCH/stormwatch.html> for maps of U.S. storms and predictions of upcoming storms.

Storms may cause fires, floods, and structural collapse that threaten loss of life and damage museum collections as well as:

- explosions
- hazardous material accidents
- transportation accidents
- utility failures

Storm vulnerabilities: Storms may cause fires and floods, noted above. In addition, a storm may cause significant kinetic damage (movement, impact, or abrasion) due to high winds, structural movement, and structural damage. The materials most frequently damaged by movement due to winds include:

- artwork in frames or under glass
- bone and ivory, particularly thin sections or slices of these materials
- brittle metal objects,
- ceramics, glass (including glass photographic plates), and mirrors
- specimens in alcohol and formaldehyde and collections housed nearby
- furniture and wood
- materials under tension, such as drums
- paper and photographs, including museum archives and documentation

Classic storm damage includes:

- broken bone, ceramic, glass, ivory, metal, and mirror items
- contamination of dry collections with alcohol or formaldehyde from wet specimens
- cracked, smashed, or otherwise damaged furniture, glass plate images, herbaria, and wet specimen jars
- missing objects that have been carried away by the winds

- soaked or water damaged archeological or ethnographic specimens, archival materials, artwork, books, furniture, museum documentation, and specimens

Storm damage prevention: Know whether you are located in an area vulnerable to major storms, such as “tornado alley,” which includes parts of Arkansas, Iowa, Kansas, Missouri, Nebraska, Oklahoma, and Texas. For example, the states with the highest rate of thunderstorm-linked lightening fatalities are in the South and Southwest, particularly Arizona, Arkansas, Mississippi, and New Mexico. Tornadoes usually occur at the end of a thunderstorm. Use the FEMA Website at <<http://www.fema.gov>> and the NOAA Website at <<http://iwin.nws.noaa.gov/iwin/nationalwarnings.html>> to identify the level of risk your park has from each of the various types of storms and to track storms as they develop.

Familiarize yourself with emergency broadcast stations on television and radio (particularly the National Weather Service radio station at 162.475 MHz-FM), with the Websites listed above, and with alarm sirens. Work with your park EOP coordinator and local emergency personnel. Ensure that your park is listed as a “must call” on telephone calling trees for storm alerts and that the MCEOP team leader is on the park EOP coordinator’s “must call” list. Storms can make access to the park to assess the collection condition difficult or impossible without an all-terrain vehicle and extensive help to remove downed trees and rubble.

Protect your collections from storms by locating your collections on level plains or slight inclines, not in valleys or flood plains, or on hill or mountaintops. Install storm shutters on your windows. Install lightning rods. Place museum storage, work, exhibit, and research rooms in buildings with good structural seals on the roof, windows, and basements. Avoid using fragile historic structures, attics, or basements for museum storage. Work with park maintenance staff to ensure that the museum structure roof, HVAC, and similar large structural elements are bolted with heavy-duty fasteners. Consult with your cultural resource management specialist before making changes to historic structures.

Place pressure-sensitive UV filtering film over glass to help minimize glass shard projectiles and window breakage. Cover windows with storm shutters and secure after first padding them with a sheet of polyethylene foam or bubble wrap to prevent shock damage. Place sandbags near doors. If possible, bolt the structure itself to the foundation and install tempered glass in museum windows. Also secure all fences and outbuildings to the building and to the ground. Some of these actions have historic structure ramifications and must be coordinated with your park historic preservation or cultural resources officer.

Ensure that all drainage and water removal systems are functioning well. Request emergency power back-up systems for environmental controls when possible. Avoid placing any materials near or in the museum that might function as projectiles in a high wind, including gravel, tiles, roof slates, benches, statuary, trash cans, and outdoor displays. Cut back all dead

branches on trees near your building. Attach guy wires to large trees near the museum building to prevent them from damaging the museum during high winds.

- **Storm watch:** Hurricane watches are issued by the National Weather Service when 74 mile-per-hour winds or greater or dangerously high water and rough seas are expected within the next 24-36 hours. A severe thunderstorm watch is issued when damaging winds of 58 miles or more or hail of 3/4 of an inch or more is expected. A tornado or winter storm watch is issued when the National Weather Service identifies classic danger signs, such as approaching storm clouds or a severe thunderstorm.

If you are in the museum when the storm watch is announced, turn on an emergency broadcast (EBS) station on radio or television or listen to National Weather Service radio at 162.475 MHz-FM for information. Listen for emergency alarm signals.

Tie down loose items outside or move them indoors. Disconnect all non-essential electrical equipment. Ensure all vehicle gas tanks are full for emergency evacuation as necessary after the storm. Check all battery-powered equipment and power back-up sources and fire fighting equipment, emergency exit lights, and back-up security systems. Capture clean water in clean jugs in case you are stranded or must do emergency clean up. Locate emergency response equipment.

- **Storm warning:** A National Weather Service storm warning indicates that a storm is imminent (within the next 24 hours). For thunderstorms, tornadoes, and hurricanes, open windows very slightly on the side away from the direction of the storm's approach. Move collection items in priority order away from glass, doors, and windows and out of basements to a safe space designated in the MCEOP. Cover collections with tarps and polyester sheeting and lash down to the heaviest furniture and to wall braces if possible.

Clear away all loose items to padded storage (use polyethylene foam or bubble wrap) in cabinets or cupboards that can be secured. Cover non-movable items, such as architectural fragments and sculptures, with plastic sheeting. Shut-off electricity and gas mains. Close storm shutters, tape unprotected windows, and lock up. Shut down all utilities, including electric appliances. Evacuate to the designated storm area, taking the visitor log and the MCEOP with you. Leave as soon as possible, avoiding flooded or washed out areas and structures. You may need to drive 20-50 miles inland to avoid hurricanes and their subsequent tidal waves and flooding.

- **Storm survival:** If you are in the museum when a storm strikes, remain in the building. Don't use elevators, matches, candles, or lighters. Stay away from upper floors, windows, glass doors, overhead lighting, and areas with unsecured furniture including filing cabinets, museum storage equipment, shelving, and small-unsecured objects. For example, don't go into wood or metal shops or into offices with lots of unsecured officesupplies. **Avoid all rooms or spaces with wide span roofs** such as barns or garages, as well as attics or top floor areas. Either get into a

windowless closet toward the center of the lower floors or stay in the center of a small windowless room, as the corners tend to accumulate debris. ***Get under a sturdy piece of furniture if possible, such as a heavy desk and use your arms to protect your head and neck.***

- ***If the storm is a tornado***, go to the designated shelter, basement, or an empty interior hallway or windowless closet. Stay away from upper floors. If you are stranded on an upper floor, go to a small windowless closet or hallway. Get under sturdy furniture and hang on. ***Note:*** The Fujita tornado scale runs from F-0, winds of up to 72 miles an hour with accompanying tree and chimney damage; to F-5, with winds of up to 318 miles per hour causing complete structures to be carried off their foundations.
- ***If the storm is a hurricane***, go to the ground floor (not the basement). Get into an empty interior hallway or windowless closet. Hurricanes frequently lead to flooding so stay above the water table or flood level. Hurricanes have a lull period, called an “eye,” during which the storm seems to have ended. Instead, the storm will return with all of its original ferocity. After the “eye,” the hurricane winds will come from the opposite direction. Don’t try to evacuate during the “eye.” Get under sturdy furniture, protect your head, and hang on.
- ***If the storm is a thunderstorm***, use only battery operated equipment and avoid all telephones, televisions, bathtubs, outlets, water faucets, sinks, metal structural elements, and outlets. If you notice your hair is standing on end (which indicates lightening is about to strike), bend forward and place your hands on your knees. Keep your feet together and crouch low. To estimate your distance in miles from a thunderstorm, count the number of seconds between the flash of lightning and the next clap of thunder, and then divide by five.
- ***If the storm is a winter storm***, find blankets and emergency heating equipment, such as space heaters. Use such equipment carefully to avoid the risk of fire. Avoid evacuating until sleet and hail have ended and authorities state that roads are passable. If stranded in a car, stay with the car unless you can clearly see nearby shelter with heating.
- ***If you hear hissing or smell gas***, open a window and evacuate the building immediately. If possible, turn off the gas main valve as you leave. If you see sparks or smell smoke ensure that the power is turned off at the main fuse box or circuit breaker. If you must step through water to get to the circuit breaker, don’t attempt to do so. Take the MCEOP and visitor log with you if possible. Try to determine if everyone has safely evacuated. Notify authorities of any missing or trapped individuals and their probable location. Wait until the maintenance liaison uses a flashlight to check for broken utility lines before turning utilities back on.
- ***If outside during a storm***, don’t try to outdrive a storm. Try to get into a building. If no building is available, stay in the car for an electrical storm or winter storm, but get out and into a ditch for a

hurricane or tornado. If in a ditch, lie down facing away from the storm.

5. *What do I need to know about medical emergencies?*

Medical emergencies can happen at any time to almost anyone.

Medical emergency vulnerabilities: Staff are vulnerable if they are inadequately trained or equipped, or if they are required to work at a pace that doesn't allow them to use appropriate safeguards. Visitors may be vulnerable if the exhibit area or research areas are improperly equipped or located. For example, if the research room is on the seventh floor and there is no elevator, a visitor might either fall or have a stroke in attempting to get to the space.

Classic medical problems include:

- accidents, such as falls resulting in broken limbs or concussion
- health hazard induced medical problems, such as those resulting from working around asbestos, chemicals, mold and nitrate (respiratory damage); ticks (Lyme disease); birds (histoplasmosis), or vermin (hantavirus)
- medical conditions such as epileptic seizure or heart attack or stroke from over exertion

Medical emergency prevention: Clearly label all exits; keep the museum storage, work, exhibit, and research areas clean and unobstructed. Attach all carpeting and mats to the floor firmly. Clearly mark and light all hazards, such as uneven floors or stairs. Check all furniture and equipment regularly to ensure that it functions well. Replace old or worn-out equipment and furniture. Limit access to dangerous areas where chemicals or high voltage equipment is stored. Get first aid training. Obtain the proper protective clothing and personally fitted rated breathing apparatuses before exposure to potentially hazardous materials. Document staff exposure.

Be aware that you must not let untrained staff onto a disaster site or expose them to any equivalent health and safety risk, or you may be subject to OSHA fines and citations. All workers at a disaster site must have training, proof of comprehension of training (such as quizzes), appropriate equipment, and a written plan. For more information on OSHA requirements, see Section D.5 and the OSHA Website in the bibliography on:

- blood-borne pathogen standard
- emergency plans and fire protection
- hazardous waste operations and emergency response
- medical services and first aid
- personal protective equipment
- respiratory protection

Know which hospital is closest and who has advanced first aid training within the park. Keep a list of emergency help sources, such as local doctors and hospitals. Train staff in CPR and other basic first aid. Post a basic first aid manual and supplies in the building. Ask all staff to have a tetanus immunization. Ensure that all staff knows how to lift without hurting themselves.

Teach all staff how to identify and protect themselves from health hazards such as animal waste, asbestos- or arsenic-contaminated materials, bacteria- and virus-contaminated materials, insects, mold, nitrate fumes, and similar health hazards.

Medical emergency survival: Remain calm. Contact the hospital immediately for assistance. Tell the hospital or ambulance staff:

- the location of the victim
- your name and telephone number
- the nature and extent of the emergency
- how the emergency happened
- any hazards that might be encountered by the ambulance on route to pick up the victim

Have someone wait outside to show the ambulance staff to the victim. Avoid moving injured or ill individuals unless they are at great risk from their surroundings. Wear nitrile gloves if blood is visible on the emergency site. Assess the level and extent of injury and deal with the most endangered individuals first, unless their problems are beyond your skill level.

Don't try to administer first aid without consent unless the victim is unconscious. Don't ever try to administer first aid beyond your training and skill level. When administering first aid, check first for life threatening conditions. Clear the victim's airway, if necessary. Don't apologize or talk about the incident or its cause to the victim, the family, or the press, other than to reassure the victim or determine the extent of the injury. Complete a case incident report for future records. Follow the park medical emergency reporting and documentation requirements.

6. *What do I need to know about utility failures?*

Utility failures may make it impossible to begin emergency recovery without back-up power and water sources. Light, drinking and washing water, heat, and a bathroom facility must be established as soon as possible to allow for emergency recovery. Often it is the temporary lack of light, clean water, and heat that can incapacitate a park during the vital first 48 hours of museum collections emergency recovery, regardless of the original type of emergency. For a summary of the OSHA requirements for salvage, see D.5.

Utility failure vulnerabilities: You may injure yourself or cause physical damage while trying to find doors, emergency equipment lights, and telephones. Vulnerabilities include:

- personal safety
- all collections lacking good alarm systems with alternative sources of power and law enforcement protection
- all collections housed in buildings with inadequate emergency lighting
- all materials housed incorrectly, maintained improperly in research room areas, or kept in spaces with inadequate walkways
- items easily destroyed by mishandling, such as bone, ceramics, glass, ivory, paper, and specimens in alcohol
- all collections susceptible to motion (kinetic) damage (See the vulnerabilities section under Storms.)

Classic utility failure problems include:

- accelerated aging of most organic collections due to environmental instability
- accidents
- breakage of brittle items, such as bone, ceramics, glass, ivory, and glass jars of specimens in alcohol and formaldehyde
- contamination of other collections from shattered specimens in alcohol and formaldehyde
- failure of cold storage for nitrate and special frozen materials leading to deterioration and potential fire hazard
- medical emergencies due to dislocation and confusion in a darkened room

Utility failure prevention: To avoid utility failures, ask your maintenance staff to regularly inspect all utilities. Work with your park EOP to meet with regional utility authorities to ensure you are alerted when an outage is planned or likely. Your space should have a back-up power source for essential services, such as emergency exit lights, HVAC, and security lighting. Consider solar powered exterior lights. Test all back-up power sources on a regular basis. Set up a regular schedule for changing and checking such batteries.

Teach all staff how to evacuate in case of a power failure. Install battery-powered emergency lights near electrical, fire, and security panels and along the evacuation route. Keep bushes, leaves, trees, and trash far from the building and any outside HVAC units. Keep a log of problems. Ask staff to use UL rated surge suppressors on all major equipment. Unplug non-essential equipment at night. Keep extra supplies of fuses, bulbs, and other materials near where they are needed. Ensure that the elevator has an emergency alarm, a working phone that goes to a 24-hour monitored area, and a trap door.

Utility failure survival: If you are in the museum during a power failure, stay calm and find your flashlights. Then, move single file from room-to-room along the evacuation route, preparing to evacuate via the stairs. Take the MCEOP and visitor log with you. The first person in line should have a flashlight. The first person in line opens all window shades along the evacuation route to increase illumination. Don't open the windows themselves. The last person in line closes the shades and doors as he or she departs.

As you leave the building, check to see if anyone was caught by the outage in the elevator. If so, reassure them that you are getting help. Secure the facility and don't allow public access until regular services and security can be restored. Help the disabled or injured to safety. Once outside, assemble in the designated area and check to see if anyone is missing. Alert designated rescue staff about missing or trapped individuals. Then contact the groups designated in the MCEOP as emergency utility contacts. Be prepared to search visitor bags, coats, and parcels if the evacuation involves entering normally restricted spaces. If a theft is discovered, notify law enforcement personnel, but don't attempt to restrain the perpetrator. Instead, note down the individual's appearance, license plate number, and type of vehicle, and collect the names of witnesses.

The team leader should close fresh air ducts, intakes, vents, and secure doors and windows as you leave to help maintain the internal environment. If the utility that fails is the sewer or water supply, which is causing flooding, follow the Section on Floods and Water Damage, in Section B.3. For long-term outages, ensure that the environmental monitors are still working. Before reentering, the maintenance liaison should use a flashlight to check for downed utility lines. If the utility line is down, use the main shut-off valves to disconnect the utilities. Follow the salvage procedures designated in the MCEOP.

7. *What do I need to know about hazardous materials accidents?*

Hazardous materials accidents may result from broken fuel pipelines, civil unrest, earthquakes, explosions, fire, fuel spillage, high-level smog, smoke, storms, terrorism, transportation accidents, volcanic fumes, warfare, and other problems. These accidents can make it impossible for staff and researchers to use collections, requiring total reformatting (copying) of all materials affected.

Hazardous materials vulnerabilities: These include hazardous objects and contamination when materials are exposed to hazardous chemicals, such as:

- any item that might weaken or lose structural integrity, such as repaired or treated materials
- archival materials, such as paper and photographs, which may stain or discolor
- textiles, which can be damaged by absorption of radiation or hazardous chemicals or which may stain or dissolve
- explosive ordnance
- glass, mirrors, ivory, ceramics or metal, which may break
- images with applied color or pigment, which may dissolve
- ivory, paper, photographs, and textiles, which may stain
- metals such as brass, bronze, copper, and silver which may corrode

Classic hazardous materials damage might include:

- adhesion of art, book, paper, and photographic items to other objects
- contamination of objects, so that they can't be routinely handled and must be treated or reformatted
- corrosion and rusting of metals
- erosion of stone or masonry
- finish loss on most materials, particularly photographs, textiles, and wood
- loss of museum records and documentation
- loss of object due to explosion
- rotting of leather
- pigment and dye loss of most painted objects
- staining and deposition of contaminants on objects, particularly bone, ivory, paper, shell, and textiles
- structural integrity loss for plaster and terra cotta
- swelling and pressure damage of wood and paper

Note: The type of damage is entirely dependent upon what is spilled. Spillages can range from toxic waste, radioactive materials, and biological waste, to gasoline. Consult a conservator for specific guidance.

Hazardous materials accident prevention: To avoid hazardous materials accidents, house your collections far from chemical storage areas, construction sites, fuel storage areas, garages, highways, laboratories, and nuclear reactors. Maintain an inventory of all hazardous materials maintained in the museum, including locations and quantities. Share copies of this inventory with your local fire department, MCEOP and EOP coordinators, and park hazardous waste coordinator. Place one copy of the inventory in the MCEOP and clearly label one map with the location of the chemicals and include this also in the MCEOP.

Label the chemicals and their storage spaces according to park hazardous waste guidance and OSHA requirements. See the OSHA Website in the bibliography and Section D.5 for an overview of OSHA requirements. Inform staff of any collection materials that may be hazards in both normal use and contaminants that may appear after a disaster. Train park staff in safe handling of chemicals, including cleaning chemicals, and contaminants. Provide regular refresher hands-on training to expand staff expertise. Provide in-depth training to the MCEOP team. Gather and maintain proof of staff and MCEOP team comprehension of training, such as tests. See the *MH-I*, Chapter 11: Curatorial Health and Safety, for more detailed guidance.

Provide staff with necessary preventive equipment as required by OSHA, including fume hoods, nitrile gloves, rated breathing apparatus fitted to the user, and washable smocks. Know the properties of the chemicals you store, such as ammonia and bleach interactions. Keep only enough chemicals for a short-term use. Select fire extinguishers based upon the types of chemicals held by the museum. Maintain a local file of how to handle exposures to these materials. Establish local eyewash and shower stations and note them on the building plans in the MCEOP. Place OSHA emergency action charts on the wall near chemical usage areas.

Be aware of how your air-intake and HVAC systems function so you can turn them off to avoid bringing contaminated air into your building. Check seals on all wet specimens regularly. Place a fixed and padded railing around shelving units holding wet specimens to limit the chance of materials falling and shattering due to heavy vibration, a storm, or earthquake. Discourage use of pesticides in or around the building.

Check potentially hazardous objects or specimens in storage before handling them or providing them to researchers if you have reason to believe they may be hazardous, such as:

- arsenic contaminated taxidermy mounts
- geology specimens that are radioactive
- historical batteries or motors

- historical farming equipment with chemical residues
- historical medical equipment
- historical motors and vehicles with gasoline and lubricants still inside
- items contaminated with vermin, feces, and other biological waste
- live ammunition
- nitrate negatives and film
- war souvenirs contaminated with radiation

If you are uncertain, have them tested before providing them. Train all staff in how to identify, handle, and work with hazardous materials. Never pour chemicals into the ground or down a drain. Work with your NPS park hazardous waste coordinator.

Hazardous materials accident survival: Evacuate the area immediately, using stairs instead of elevators. Assess risks as you evacuate (spills, power lines down, fires) so you can alert authorities. Check to ensure that no one is trapped in the elevator. Help injured or disabled people. Don't open doors and windows as you evacuate. Keep the building shut down with air handling off. Contact authorities immediately. Avoid re-entering the area. Move to a safe distance from the affected area, taking your visitor log and MCEOP with you. You may have to move several miles distant if fumes are evident. Try to determine if everyone has safely evacuated the building. Alert professional rescue personnel about any missing individuals and the nature and extent of the disaster. Call the hospital for emergency medical help.

As soon as possible, set up a triage area for administration of first aid. Use nitrile gloves to remove contaminated clothing and wash affected skin with much fresh water as soon as possible. Follow the instructions under medical emergencies, but ***don't attempt mouth-to-mouth CPR on unconscious persons who may have breathed in fumes***, as you place yourself at risk. Follow the MCEOP guidelines on specific actions for the types of hazardous materials your park holds.

8. *What do I need to know about transportation accidents?*

Transportation accidents may result in standing pools of fuel, which are fire and explosion hazards; toxic fumes from fires; spillage of chemicals and hazardous wastes, and similar contaminants that can pose severe health and safety threats to staff, as well as museum collections.

Transportation accident vulnerabilities: See storm damage and hazardous materials accidents vulnerabilities.

Classic transportation accident damage: See hazardous materials accidents.

Transportation accident prevention: Don't place museum storage, work, exhibit, or research rooms within proximity to active train tracks, major airport flight paths, major highways, and similar transportation routes.

Transportation accident survival: Evacuate the building, if possible. Assess risks as you leave, for example, fires and major fuel spills. Check the elevator for trapped people. Help injured or disabled people. Contact authorities immediately. Avoid re-entering the area. Move to a safe distance from the affected area. Try to determine if everyone has safely evacuated the building. Alert professional rescue personnel about any missing or trapped individuals. Contact park and local authorities. Provide first aid assistance as necessary.

9. *What do I need to know about civil unrest, vandalism, and terrorism?*

Civil unrest, vandalism, and terrorism can limit access to collections or cause their damage or destruction. Planning for them is challenging, as it involves being aware of potential political and social issues related to your park. Try to anticipate potential problems, such as demonstrations that are symbolically or politically linked to your park. Terrorism is a relatively unlikely risk for most parks when compared to the much greater risk of fire or flood damage. However, terrorism is increasingly a force in modern life. Museums must protect themselves from such activities. The highest risks for demonstrations and terrorism are sites that embody American history or that have high symbolic value, such as the Statue of Liberty, Mount Rushmore, or the Washington Monument

Civil unrest, vandalism, and terrorism vulnerabilities: The materials most vulnerable to damage include:

- collections lacking good alarm systems and nearby onsite park police protection
- materials inadequately housed
- items easily destroyed by mishandling, such as ceramics, glass, paper, specimens in alcohol or formaldehyde, and textiles
- items in parks with employee relations problems

Classic civil unrest, vandalism, and terrorism damage includes:

- explosion damage resulting from bombs
- fire and smoke damage
- fouling of collections with food, garbage, and human waste
- graffiti marking on objects, such as paper

Civil unrest, vandalism, and terrorism prevention: To avoid problems with civil unrest, vandalism, and terrorism, house your museum collections storage, work, and research room areas in secured park areas away from ceremonial spaces or public spaces. Secure collections if demonstrations are planned. Maintain security, particularly key control and alarm systems. Ensure that you have back-up power sources for your security system and emergency evacuation lighting in case of emergency utility failures. Follow established access procedures as described in *Museum Handbook*, Part III

(*MH-III*), Chapter 1: Evaluating and Documenting Museum Collections Use. If a researcher becomes distraught, contact park police for assistance. Never physically restrain a visitor or staff member.

Civil unrest, vandalism, and terrorism survival: To survive, notify park and local authorities immediately of any incidents. Follow their instructions. Remain calm. Never argue with armed individuals. Stay away from windows and glass doors. Evacuate as instructed by authorities after first ensuring that no bombs or other hazards exist on the evacuation route. Check the area to which you are evacuating as well for hazards and bombs. Be aware that bombs often are planted to go off serially. Help injured and disabled individuals evacuate. Assess risks as you leave, for example, the number and location of armed individuals and the nature of barricades. Close all doors and windows as you leave. Check all elevators and bathrooms as you leave for trapped individuals. Take your MCEOP and visitor log with you as you leave so you can share them with bomb squad personnel. Call for medical help immediately. Have park law enforcement fill out a case incident report. Work with your park law enforcement and public relations officers on follow-up actions.

10. *What do I need to know about explosions and bombs?*

Explosions are a greater threat to most parks museum collections than terrorism. Nitrate based still photographic negatives and motion picture film are perhaps the greatest explosion threat to museum collections. Copy nitrate film, inspect it, and don't store it in parks for longer than it takes to copy it (less than 5 years). See *MH-III*, Appendix M: Management of Cellulose Nitrate and Ester Film.

Explosion and bomb vulnerabilities: See hazardous materials accidents and storm damage. Explosion vulnerabilities include:

- black powder and other weaponry or supplies, such as ordnance
- nitrate negatives or motion picture film in quantities of more than 35 pounds or that are deteriorated or largely motion picture or large format negatives and X-ray film (See Appendix M: Management of Cellulose Nitrate and Ester Film.)
- gas appliances older than 10 years that are not regularly inspected
- nearby fuel storage or transportation storage facility such as a garage or service station
- substantial wet specimens in a building where smoking is allowed
- vehicles, power tools, and motors in collections that have not been adequately drained of fuel

Classic explosion and bomb damage: See fire damage, hazardous materials damage, and storm damage.

Bomb threat: If you experience a bomb threat, listen for background noise and try to distinguish the caller's age, sex, and accent. Write down every word said, paying particular attention to when the bomb will explode, where

it is, what kind of bomb it is, and why it was placed. Contact law enforcement immediately, unless the explosion is imminent. If the explosion is imminent, evacuate immediately, sounding the fire alarm as you leave.

Otherwise, if the explosion is not imminent, investigate the evacuation route and staging area to ensure that there is no bomb there as well. Then, evacuate the area, sounding the fire alarm, if possible, and closing all doors and windows as you depart. Help handicapped or injured individuals evacuate and check all elevators for trapped individuals. Take the MCEOP and the visitor log with you as you evacuate. Immediately contact park and local police from a separate building. Keep well away from the area. Try to determine if everyone has left the building. Notify rescue personnel if anyone is missing.

Explosion and bomb survival: If you are in the museum during an explosion, take cover under a sturdy table or desk. Stay far away from windows, mirrors, exhibit cases, unsecured equipment, museum storage areas, office bookcases, and file cabinets. Watch for falling objects.

Expect additional explosions, so evacuate with care along routes that have been checked for safety to assemblage areas that have been checked for hazards and additional bombs.

Evacuate via stairs, not elevators. Help injured or disabled individuals. Don't light matches, candles, or lighters, as gas lines may be broken. Stay away from areas with small hard objects such as machine or wood shops, kitchens, or museum storage. Call authorities as soon as you are outside and safely away from the building. If a fire results, stay well clear of the fumes, particularly if the fire is a nitrate fire. Fill out a case incident report.

11. *What do I need to know about structural collapse?*

Structural collapse caused by accidents, earthquakes, explosions (particularly nitrate explosions), fires, floods, storms, terrorism, and neglect pose a significant threat to museum collections. Structural damage leads to broken, cracked, or buried items. Structural collapse may cause fires due to broken gas lines, as well as water damage to collections from broken pipes, and sewer, fuel, and power lines.

Structural collapse vulnerabilities: See Storm Vulnerabilities and Explosion Vulnerabilities.

Classic structural collapse damage: See Explosion, Fire, and Storm Damage Sections.

Structural collapse prevention: To avoid structural collapse, have your building inspected by park maintenance and the regional architect if you see any physical problems such as cracked or weakening support beams or worse, sagging floors or ceilings. See Earthquake Prevention in Section B.12 for further guidance. Avoid excessive floor loading until structural integrity and floor loading capacity can be determined. To minimize potential problems, bolt non-historic bookcases, file cabinets, and heavy equipment and furniture to walls.

Structural collapse survival: If you are in a building when it collapses, take cover under a sturdy desk or table or in a supported and reinforced doorway, preferably in the center of the building. Avoid all spaces with wide span roofs, such as auditoriums, barns, and garages. Stay away from filing cabinets, bookcases, overhead lights, electrical equipment, mirrors, glass doors, and rooms with many unsecured objects, such as metal shops. Before evacuating, inspect the evacuation route and staging area to ensure that they are safe and not in a state of collapse. Stay out of elevators, but listen for trapped individuals.

Once the collapse has stopped, evacuate cautiously using the stairs or a door or window. Don't use matches, candles, or lighters for illumination as gas pipes may be broken; use flashlights. Take the MCEOP and visitor log with you if possible. Help handicapped or hurt individuals to move to a safe and stable evacuation assemblage area that has been checked for problems. Avoid running for the stairs at the first sign of trouble, as they may be broken or full of stampeding people. Move cautiously. Be prepared for additional shocks and structural instability.

Stay away from glass windows, doors, exhibit areas, overhead lighting fixtures, and bookcases as you evacuate. Avoid tall, heavy, and unsecured furniture. Call authorities once you are safely away from the building. Try to determine if everyone has safely evacuated. Notify authorities of missing or trapped individuals and their likely location. Set up a medical triage station. Call for medical assistance. Help care for injured people to the extent of your medical knowledge and skills.

12. *What do I need to know about earthquakes?*

FEMA experts estimate that 39 out of 50 states in the U.S. are at risk of an earthquake. We can't yet predict earthquakes accurately; however, we are getting much better at estimating earthquake probabilities. For example, scientists predict a 60 percent chance of an earthquake greater than 6.7 magnitude in Southern California in the next 30 years. Based on long-term records of the U.S. Geological Survey (USGS), scientists expect about 18 major earthquakes (7.0 magnitude or greater) and one great earthquake (8.0 or greater magnitude) annually worldwide.

Of the last 15 large earthquakes in the U.S., 10 were in Alaska and 3 in California, while the others were in Hawaii and Missouri. On the continental U.S. the last 15 largest earthquakes include 8 in California; 3 in Missouri; and 2 in Nevada; with the others being in Montana and Idaho. Alaska far exceeds all other earthquake zones in the U.S., with over 82 major quakes of 7.0 or greater since records were first kept in the late 18th century.

Earthquakes may abrade, break, smash or damage items and buildings or drown them in mudslides, flooding, or under collapsed buildings. Earthquakes can also be an aftereffect of volcanic activity. Almost all kinds of damage listed under "Fire," "Flood," and other emergencies covered in this Section may happen during earthquakes as well. Generally earthquake damage levels depend upon the earthquake magnitude, duration, distance from the epicenter of the quake, the type of structure, the type of ground on which your structure rests, and the level of preparedness. **Note:** The thicker and looser the soil on which your structure rests, the more amplified the earthquake effect will be.

Earthquakes may lead to explosions from broken gas mains, floods from broken water lines, and similar damage. In addition, earthquakes may cause a major loss of original order for archeological objects and archives and records. For archeological and archival materials, the original order of the collection may provide information on the circumstances of creation or usage and relationship to other materials within the collection. Losing this arrangement through an earthquake, flood, or other disaster can significantly diminish the value of the collection.

Earthquake vulnerabilities: If your collections are housed in an unreinforced structure in an earthquake zone, you are at risk if basic prevention steps aren't taken. Vulnerability of collections is also dependent on what steps you have taken to mitigate risk, such as placing restraining bars or cords on shelving. See *MH-I*, Appendix F: Collections Management Checklists, Checklist for Preservation and Protection of Museum Collections, Question B.23. Be aware of tectonic plate fault lines in your area and of your region's estimated probability of an earthquake. In many areas experts have predicted the actual size and impact area of future earthquakes. See the Bibliography under Earthquakes for sources. Work with park architects and maintenance staff to reinforce your building and storage equipment appropriately. See Fire, Hazardous Material Accident, and Storm Vulnerability for further information.

Classic earthquake damage: See Fire, Hazardous Material Accident, and Storm Damage.

Earthquake damage prevention: Avoid placing museum storage, work, exhibit, or research spaces on or near geological fault lines. If this is impossible, follow the guidance in the resources in the bibliography on how to secure collections and furniture to avoid destruction in an earthquake. Select a building that has been built or modified to withstand an earthquake. Standard earthquake modifications include the addition of sheathing on roofs and floors and of steel braces, frames, or brackets. Reinforce walls, beams, chimneys, and damaged mortar. Securely install track-type lighting. Have the building inspected by a structural engineer and your park maintenance staff to ensure that it is structurally sound. Identify risks from surrounding structures or trees. Cut down dead limbs. If necessary, place guy wires on nearby trees.

For masonry, bolt roofs to walls and walls to foundations using steel brackets. Reinforce building openings, such as crawl spaces, doors, and windows by placing steel frames around them or steel beams in them. Repoint mortar as necessary. Check with park architect and maintenance staff for help or talk to your regional/SO curator. Keep all aisles, walkways, and doorways clear when planning your space.

Select steel shelving with welded frames and cross-braces but without tightly sealed and enclosed air pockets that may promote floating during a flood. Bolt shelving, filing cabinets, map cases, and major furniture to solid structural components, such as walls, ceilings, and floors, far from doors, escape routes, and computers. Pad all shelving with polyethylene foam sheets to limit kinetic damage. Store fragile items, such as ceramics, glass, and bone, in hollowed out blocks of polyethylene foam or use fishing line or cloth straps to hold the items to their shelves. Place small items in polyethylene padded drawers of cabinets, map cases, or small boxes. Pad large, tall, or

heavy items, then place them horizontally on bottom shelves. Use restraining bars or cords and similar devices to prevent materials from rolling off open shelves.

Remove artwork from glass-covered frames. Store unframed artwork flat in solandar boxes. If you decide not to remove artwork from frames, use steel S-hooks or double-end bolt snaps to secure framed objects at their top and bottom to storage screens. Replace glass shelves in exhibit cases and housing with tempered glass or Plexiglas. Slip a wooden rod into the handles of filing cabinets to ensure that they are held closed. Purchase Velcro type tie-downs for computers.

Earthquake survival: Stay inside. Go to a small windowless room in the center of the building. Stay out of rooms with wide span roofs, such as barns and garages, and away from museum storage areas or any space with lots of furniture and loose materials, such as metal shops or libraries. Get under a heavy piece of furniture, such as a desk. Duck, cover your head, and stay curled up until the shaking is over. Stay away from windows, overhead fixtures, bookcases, filing cabinets, loose tools, and electrical equipment. Prepare for aftershocks. Put out small fires. Follow the guidance under structural collapse (Section B.11) and fires (Section B.2) above.

13. *What do I need to know about volcanoes?*

More than 80% of the earth's surface above water is of volcanic origin. There are currently about 53 historically active volcanoes in the U.S. of which 43 are in Alaska according to *Volcanoes of the World*. According to FEMA, all parks in Alaska are at the highest level of risk. Moderate-risk parks include those in the Pacific Rim states of California, Hawaii, Oregon, and Washington. Montana and Wyoming are at a slightly lower level of risk. All other states are at a still lower level of risk with a few isolated exceptions, such as Hot Springs National Park.

Some parks have active or previously active hot springs and volcanoes, such as Capulin Volcano National Monument, Crater Lake National Park, Haleakala National Park, Hawaii Volcanoes National Park, Hot Springs National Park, Lassen Volcanic National Park, Lava Beds National Monument, Mount Rainier National Park, and Sunset Crater Volcano National Monument. Such parks need to be very alert to increased levels of risk. Besides the obvious concern of being buried by lava if museum storage is too close to lava tubes or pathways, volcanoes emit hot ash and acidic gases and cause mudslides, flash floods, tidal waves, earthquakes, rock falls, and explosive lateral blasts that shoot hot rocks for up to 20 miles. Noxious and occasionally lethal fumes can spread up to 100 miles. Acidic and corrosive ash can spread over 1,000 miles. For lists of active volcanoes see <http://www.volcano.und.nodak.edu/wvdocs/volc-images/>.

Volcano vulnerabilities include:

- *all collections on open shelves*, which can be coated with corrosive and acidic volcanic ash
- *archival materials*, particularly architectural drawings and plans, documents, electronic records, photographs and film, and sound recordings, which may suffer abrasion, embrittlement, oxidation, loss of data (magnetic and electronic), and silvering out

- *artworks*, particularly chalk, charcoal, collages, conte crayon, gouache, montages, paintings, both on canvas and on panels, polychrome sculptures, and watercolor
- *bone and ivory*, which may be discolored or lose applied color or be stained
- *baskets and similar fibrous materials*, such as sandals, which may be stained or lose color
- *ceramics*, which may be abraded or scratched or lose color
- *furniture/wood*, which may lose surface finish or suffer oxidation of attached metals
- *glass*, which may be abraded or scratched
- *metal objects*, which may be scratched or oxidized—silver may corrode due to fumes and toxic gases
- *natural history specimens*, which may be stained or covered with ash
- *textiles*, which may suffer from staining or weakening

Classic volcano damage: These volcanic gases, mud, lava, and ash pose particular threats as they:

- *corrode and oxidize* metal and photographs
- *damage surface finishes* on paper, photographs, wood, textiles, and other objects
- *destroy magnetic media*, particularly audiotapes, digital files, software, and videotapes
- *embrittle* paper, photographs, textiles, and other objects
- *fade and/or stain* art work or paper

Volcano damage prevention: Avoid placing museum storage, work, exhibit, or reading room areas near active volcanoes. Be aware of any road, or river, valley, or other geological feature that could lead the lava and mud to the museum. Purchase vacuuming equipment with a water filtration system. Check on purchasing special furnace filters for screening out particulate ash. Know how to totally shut down the museum air intake system and tape up all ducts, valves, vents, and windows.

Volcanic activity alert: If a volcanic activity alert is announced, evacuate visitors and non-essential staff first. Then work with essential staff to evacuate collections to the extent possible to a safe alternative facility at least 20 miles from the volcano. Before evacuation, staff should change into long-sleeved shirts and pants and locate goggles and dust-masks or rated breathing

apparatuses that have been fitted to each staff member. Turn off all air intake equipment and ensure that the ducts and vents are taped shut. Disconnect all electrical equipment except essential emergency equipment. Shut down utilities. Tape shut all window gaps and poorly grouted areas. Place coverings over chimneys.

Wrap fragile materials and shelves in plastic to prevent volcanic ash build-up. Remove all sources of humidity, such as dehumidifier pans and standing water, as volcanic ash combined with water can produce sulfuric acid. Try to keep the humidity low.

Check all emergency supplies and emergency equipment. Fill evacuation vehicle gas tanks. Don't leave car engines running longer than necessary as volcanic ash and fumes can destroy car and truck engines. Extinguish all fires in non-essential appliances and unplug them. Evacuate, providing assistance to disabled and injured people as necessary. Ensure that no one is left trapped in the building, such as in an elevator. Take the MCEOP and visitor log with you. Travel on high ground as much as possible, avoiding areas where potentially lethal lava, mudslides, and fumes can accumulate. Attempt to get at least 20 miles from the volcano; some danger from fumes and gases still exists up to 100 miles away. Avoid routes with numerous bridges, valleys, tunnels, or bottlenecks.

Volcanic activity survival: Evacuate as ordered when the alert occurs. Wear breathing apparatus and goggles, if possible; otherwise keep a damp cloth over your mouth and nose. People can die from breathing toxic volcanic fumes. Stay away from low lying areas and all lava flows, volcanic ashfall areas, and mudflows. Go to high ground and keep moving away from the volcano. Use a cell phone or mobile phone, if possible, to determine if your evacuation route is safe and that all bridges are still available. Assist disabled and injured individuals. Notify authorities of any trapped individuals and their likely location.

Don't return until an "all clear" is announced and park authorities indicate it is safe. Wear goggles, a scarf or hat, and an appropriately rated breathing apparatus fitted to the wearer, as well as a long-sleeved smock and slacks during recovery work. Clear roofs, gutters, and drains of ash fall as it can become heavy enough to collapse buildings. Don't turn on the air handling system until the air has cleared and ash has been removed. Keep doors and windows closed. Keep the environment very dry. Put mats outside the building to avoid tracking ash inside. Place plastic sheeting on the floors near any entry points and windows to capture ash. Vacuum everything. Wash nothing. Avoid rubbing, wiping, or washing surfaces. Change building air filters very frequently.

C. Analysis of Risk to Your Park's Museum Collections

Not all parks are at equal risk for all types of emergency. For example, Statue of Liberty National Monument is at greater risk of from flooding, storms, terrorism, than it is volcanoes and mudslides. Hawaii Volcanoes and to a lesser extent Mount Rainier are at greater risk of volcanic activity and mudslides than of terrorism.

Each park and center has a unique blend of:

- **existing hazards** (such as a river, high water table, or near-by cliff or highway), *and*
- **collection vulnerabilities** (the size and type of collection housed in each at-risk structure and the level of the loss occurring when a disastrous event of a certain magnitude and type occurs)

Taken together, hazards and vulnerabilities equal risk.

Risk assessment is a matter of:

- **analyzing the hazards and vulnerabilities** of a park's museum collections (See Figure 10.2.)
- **defining acceptable risk levels** for each type of potential emergency
- **making decisions** about acceptable prevention and mitigation (contingency response actions)

All emergencies have one common characteristic: if not dealt with rapidly, thoroughly, and thoughtfully, emergencies get significantly worse and become disasters.

1. *How do I assess the level of risk to my park for various kinds of emergencies?*

Use the risk assessment worksheet (Figure 10.2) to determine the risk and hazard factors your park faces for each type of emergency. Mitigate these risks, wherever possible. Request funding to mitigate risks that the park can't afford. If after completing the worksheet you determine that your park has many more risks for fire than for earthquake, spend your park's money on more fire mitigation than on earthquake mitigation.

2. *How do I determine which emergencies to assess?*

Read the park administrative history and talk to park staff who have been in the park the longest. Ask them if the park has ever had a problem with each type of emergency. Call your park EOP coordinator to try to discover the frequency of this type of emergency in your site's area. Talk to your local public library reference librarian for help. Use the Websites listed in the bibliography—some of which provide specific risk information on certain types of disasters, such as:

- Floodcast Website at <<http://www.earthsat.com/flood/floodcast.html>>
- U.S. Fire Administration Website at <<http://www.usfa.fema.gov/>>
- Volcano World, the active volcano site, at <http://www.volcano.und.nodak.edu/wvdocs/current_volcs/current.html/>
- National Oceanic and Atmospheric Administration's flood and storm watch and warning page at <<http://iwin.nws.noaa.gov/iwin/nationalwarnings.html>>
- Earth Watch site at <<http://www.earthwatch.com/STORMWATCH/stormwatch.html>>
- Federal Emergency Management Agency (FEMA) Website at <<http://www.fema.gov>>

3. *How do I complete the Risk Assessment Worksheets?*

Look at Figure 10.2. The worksheet is a list of risk factors (for example, having the museum storage structure on a flood plain) that relate to the 11 key types of emergencies described in this chapter. Read the list, to remind yourself of the various risks and hazards that your park faces for each type of emergency. If you wish to fully assess each facility in your park for risks and hazards, as you read the worksheet determine if each point applies to the particular facility you are assessing, then answer each question "yes" or "no." If you answer "no," this factor is a risk for the listed emergencies. Only use the NA or "not applicable" category if the risk factor has no relevance to your facility. Repeat the task until you have completed the form for each facility that houses museum collections. References to the Checklist for Preservation and Protection of Museum Collections in Appendix F within a question indicate when answers may be found in the Checklist. When checklist requirements match Risk Assessment risk factors, the Checklist section letter and question number is noted in the final column.

When you have completed the Risk Assessment Worksheet, add up the number of "no" responses that apply to each emergency type (fire, flood, etc). The more "no" responses, the greater your risk for this type of emergency.

4. *How do I determine the likelihood of a particular type of emergency?*

Use the Emergency Master Planning Worksheet (Figure 10.1a). Once the Risk Assessment Worksheet (Figure 10.2) is completed for all types of emergencies, you should have a sound grasp of what remains to be done. You can now identify the greatest risks and hazards for your collections by prioritizing your risks on the Emergency Planning Master Worksheet. You can focus the largest part of your planning energies on the likeliest forms of emergencies, buying the necessary supplies and training staff most thoroughly in activities for those types of emergencies.

Use the Emergency Planning Master Worksheet to identify the sort of mitigation you should consider undertaking for each facility. Note on the Emergency Planning Master Worksheet which facilities and what types of emergencies were assessed. Make note of mitigation actions needed. While the Emergency Planning Master Worksheet contains spaces for tracking all conceivable types of emergencies from fires and floods to volcanoes, you may already know that your park has little or no risk from certain types of emergencies. When a particular type of emergency is very unlikely, such as a volcano in Iowa, you will be able to focus on more likely types of emergencies. As you complete the worksheet, do the steps listed in C.2 (interviewing staff). Also consider the number of “no” responses when you prioritize your risks.

5. *Once I have completed the Emergency Planning Master Worksheet, what new information do I have?*

Following this exercise, you should know:

- which emergencies are most likely for your park and which are your greatest risks as noted here (your emergency priorities)
- specific situations in your park that place museum collections at risk for each type of emergency
- some basic steps for preventing these emergencies (also see Sections B.2-13)

Your MCEOP should address your emergencies in priority order as established by this risk assessment procedure. The greatest amount of attention on how to plan for, mitigate, survive, and recover from an emergency should be focused on the emergencies you are most likely to face. Secondary types of emergencies, such as volcanoes in New England or tornadoes in California, may be dealt with more generically as part of a general category of similar disasters, such as “earthquakes and volcanoes” or “storms.” Focus your planning, training, supply, and other resources on the high priority emergencies that you are likely to face.

6. *How do I limit risks to my museum collections and staff?*

After you have determined your most likely emergencies, you should begin to limit risks. There are a number of tools you can use to identify specific risk factors to mitigate. First mitigate the conditions listed on the Risk Assessment Worksheets (the “no” responses), particularly those that are on the Checklist in *MH-I*, Appendix F. Second, mitigate risks under the header “Prevention” in Sections B.2-13. Taking the steps recommended in these sections should greatly reduce the possibility of an emergency becoming a disaster.

D. Prioritization of Museum Collections for Salvage

When an emergency threatens, you may be required to:

- move materials fast:
 - to an off-site building
 - to a different building within the park
 - to a different floor of the same building
 - to the tops of existing shelving and furniture
 - to an interior area out of the path of the emergency
- salvage materials from fire, kinetic, smoke, storm, volcanic, or water damage
- send collections to cold storage, a safe workspace, or to a conservation laboratory

Prioritize park collections for recovery so you will not have to make vital relocation, salvage, or treatment decisions when you are under stress, without full information, or operating without power, lights, or automated systems.

1. *What preliminary work should I do?*

Before you begin prioritizing your collections for salvage:

- ***Evaluate your structures*** containing museum collection storage, work, exhibit, and research spaces as described in Section C.1. If you have multiple structures, determine if some of these structures face greater hazards than others. For example, is one structure in a flood plain, near a tidal river, or situated near a major highway?

If so, you may need to prioritize your various structures by the types of disaster they may experience. Review the Risk Assessment Worksheet (Figure 10.2).

- ***Review your risk assessment exercises.*** See Section C.1 and Figures 10.1, Emergency Planning Master Worksheet, and 10.2, the Risk Assessment Worksheet.
- ***Review your types of collection materials*** by walking through your collection storage, work, exhibit, and research spaces and looking at your Scope of Collection Statement, Collections Management Report (CMR) and your Collection Management Plan (CMP)
- ***Determine your criteria*** to be used in setting your MCEOP salvage and treatment priorities

- **Talk to your staff, cooperators, contractors, and collaborators** about salvage and treatment priorities

2. *What criteria might I use to set priorities?*

Many factors may be important in salvage recovery. Always the single most important criterion is prevention of loss of life. The health and safety of staff, visitors, and others comes above all collections concerns. After health and safety issues, preservation of the most valuable portions of the museum collections is essential.

Salvage priorities are almost impossible to establish during salvage. Your MCEOP should include salvage priorities. The basic rule for setting priorities is to salvage materials in affected or damaged spaces first. Within the affected spaces, follow the established salvage priorities as expressed in written labels or color codes. For example, you may wish to keep the system simple setting only three priority levels:

- **High priority materials** receive a green indicator label or the code HP.
- **Moderate priority materials** receive a blue indicator label or the code MP.
- **Low priority materials** receive a red indicator label or the code LP.

The most commonly used evaluation criteria for identifying these most valuable museum collection components are:

- **Value/Significance**, which includes factors such as:
 - **artifactual value** (intrinsic value as material culture)
 - **associational value** (direct link to eminent individuals or groups, famous events, projects, or activities)
 - **informational value** (as the material records important data on the topics, activities, individuals, groups, and places that form part of the park's Scope of Collection Statement)
 - **evidential value** (as historical or legal proof, such as land records or vital records)
 - **administrative value** (as active records used by the park for essential resource management activities)
 - **monetary value** (as determined by the marketplace)

Most museum collections have some artifactual value; some however, also have important associations to major figures and events, major value as information (such as type specimens), or evidential value for legal cases or as historical proof of a contested point. See *Conserve O Gram (COG) 19/10, Reformatting for Preservation and Access: Prioritizing Materials for Duplication*, for a fuller discussion of these types of value and how to use them for prioritization of museum collections.

- **Risk**, which includes hazard likelihood plus vulnerability due to the media, process, format, and material, and local housing and storage concerns. Again see *COG 19/10* (listed above).
- **Usage**, which includes the frequency of usage by scholarly researchers, students, and associated communities. **Note:** Usage can affect value and significance—for example an upcoming anniversary or planned exhibit may give a collection or item added temporary significance; or risk can be affected by usage—for example a traveling exhibit may provide significant additional risk. Placing an image of a valuable collection item on the Web if you lack good security can also pose a risk as you are increasing the number of people aware of its existence, a certain percentage of whom may be less than honest. Instructions on how to judge these usage levels is included in *COG 19/10*.

In determining salvage priorities for specific types of emergencies, set up a numeric chart like that in *COG 19/10*. This is a simple scale that judges each group of items being assessed as high, medium, or low for value, use, and risk. For your salvage plan when filling in the numeric chart, consider weighting your criteria giving triple weight to risk factors, so that high risk items are 9 points, medium risk items are 6 points, and low risk items are 3 points. You may score all three criteria the same (high=3 points, medium=2 points, and low=1 point) or differently as shown in the example below.

Example: If the affected items include:

- Item 1: a group of tanned Buffalo hides collected in 1950 for use in interpretive programs
- Item 2: a set of undecorated fruit gathering baskets made by a 12 year old Colonial girl in 1769
- Item 3: several veneered musical instruments including a violin once owned by John Quincy Adams
- Item 4: paleontological specimens in shale collected by the first park geologist
- Item 5: ledger books documenting the botanical collecting activities of the first park botanist
- Item 6: typewritten correspondence between the park founder and various historical figures
- Item 7: rare mineral specimens collected by John Muir
- Item 8: portrait miniatures of unidentified subjects on wood

- Item 9: metal architectural fragments (lead gutters predominantly) from the first park visitor center
- Item 10: models of lead cannons acquired from a collector

You will fill out a form like the example below, which assigns high, medium, or low numerical values for each of the categories. **Note:** Since this exercise is for emergency salvage and planning purposes, this example uses a weighted scale that places highest emphasis on risk, then value, then usage. The numerical values are as follows:

For Risk: High=9; Medium=6; and Low=3

For Value: High=6; Medium=4; and Low=2

For Use: High=3; Medium=2; and Low=1

For Total: High=13+; Medium=7-12; Low=1-6

Item Number and Descriptor	Risk Score	Value Score	Use Score	Point Total	High, Medium or Low?
1-Buffalo Hides	3	2	1	6	Low
2-Colonial Baskets	6	6	1	13	High
3-Musical Instruments	9	6	2	17	High
4-Paleontological Specimens in Shale	9	2	1	12	Medium
5-Botanist's Ledger Books	6	6	3	15	High
6-Correspondence	6	6	2	14	High
7-Mineral Specimens	3	6	1	10	Medium
8-Portrait Miniatures	6	2	3	11	Medium
9-Architectural Fragments	3	2	1	6	Low
10-Cannon Models	3	2	1	6	Low

After scoring each group of items on value, use, and risk, add the total number of points and prioritize the various groups of items by their numerical scores. The higher the score you assign, the higher the material's salvage priority. In the above example, you would remove the musical instruments (particularly the Adams violin) first, followed by botanist's ledger books, the correspondence, and the Colonial baskets.

When assigning numbers, focus on groups of materials rather than individual items. For example, assess your basket collections, your botanical specimens, your metal sculptures, against your archival materials. This procedure will be far too labor intensive to do at an item level. Review the vulnerabilities and classic damage information in Sections B.2-13 for help in judging risks. Use your researcher registration forms and logbook to judge usage. Use your curatorial judgment and the guidance above to judge value.

3. *How do I ensure my priorities are followed?*

To make it easy to follow your priorities, use color coding as described in Section B.2.

When an area or space is in an emergency situation, remove or salvage items in order by priority as expressed by the color or coded labels. If you color code, choose a logical sequence of colors.

4. *How should my plan indicate my priorities?*

Regardless of how you choose to indicate priorities, ensure that samples of your marking system are included in your emergency operations plan so that it is very clear which materials are to be removed first. See the First 48 Hours Emergency Response Checklist (Figure 10.3).

5. *How do I salvage my collection?*

OSHA requires that all work sites, including emergency salvage sites, have certain features and meet certain requirements, including:

- bathroom facilities
- washing facilities with a clean water supply
- a sound structure with no sagging floors or walls
- no uncovered gaps or holes in the floor (Gaps larger than 4 feet require a guard, railings, or covers.)
- ground fault circuit interrupters on all outlets used for power tools and tools within 10 feet of water
- a handrail along each side of stairways with more than 4 steps and a rise greater than a 30 inches
- no unidentified substances contaminating the space
- no garbage and toxic chemicals, including:
 - animal and human waste, including bodies, excrement, and other biological waste, including bird and vermin nests, used condoms, and needles

- asbestos waste from insulation; ceiling, floor, wallboard and acoustic board, and tile; some geological specimens, such as talc; historic papier mache and plaster materials, including stage backdrops; roofing materials; spackle, and wiring coatings and insulation
- lead paint waste
- moldy and mildewed items
- pesticides and chemicals, including spilled chemicals, old containers, and contaminated objects such as taxidermy specimens and pesticide-treated wood waste

If these conditions can't be met, only MCEOP staff who have had HAZMAT training, as required by OSHA, can undertake disaster recovery in the space. All staff working anywhere near any of these hazards must be verbally warned of them. Once judged structurally safe, the composition of any residue (soot or flood mud) should be identified. Look for mold growth, chemical and biological residue, carcinogens, and toxic substances. Problematic materials include:

- ***hazardous residues***, such as:
 - arsenic residue from old taxidermy specimens
 - asbestos particles (from insulation, ceiling and floor tiles, wallboard, plaster, spackle; and other building materials and some taxidermy specimens that can cause lung ailments)
 - cadmium
 - dioxin
 - blood (rickettsia, spirochetes, and viruses)
 - fire extinguishers containing carbon tetrachloride
 - gasoline
 - gun powder
 - lead powder residue (from lead shot, paint, tiles, and toys), which if it becomes dust, can cause many medical problems, including blood and brain problems
 - mercury gauges and daguerreotype equipment
 - old medicines
 - old pesticide residues on farm machinery

- polychlorinated biphenyls (PCBs) in soot
- radioactive source materials, including radium dials on old instruments
- ***dead animals, excrement, and nests***, which can cause:
 - cholera
 - dysentery
 - hantavirus (from rodent waste)
 - hepatitis
 - histoplasmosis (from bird waste)
 - salmonella enteritis
 - shigella
 - tetanus
 - toxoplasmosis
- ***microorganisms***, such as:
 - ***bacteria*** (Anthrax, Brucellosis, Campylobacteriosis, Colibacillosis, Hepatitis, Legionellosis [Legionnaire’s disease], Leptospirosis, Melioidosis, Nocardiosis, Plague, Psittacosis, Salmonella Enteritidis, Shigella, Tetanus, and Tularemia)
 - ***fungi and yeasts*** (particularly deadly Aspergillum, Blastomycosis, Candidiasis, Chromomycosis, Coccidioidomycosis, Cryptococcosis, Histoplasmosis, Ringworm, and Stachybotrys atra)
 - ***insects*** (ticks, fleas, lice, mosquitoes, sandflies, and ticks, particularly in high stagnant water situations leading to many diseases including Babesiosis [ticks], Leishmaniasis [sandflies], Lyme disease [ticks], Relapsing fever [ticks], Rocky mountain spotted fever [ticks], Tularemia [ticks], Typhus [lice])
 - ***parasites*** (Acariasis, Babesiasis, Cryptosporidium parvum, Clospora, Hymenolepiasis, Leishmaniasis, Strongyloidiasis, Toxoplasmosis)
 - ***viruses*** (Hantavirus [vermin waste], Hepatitis [skin contact with infected body fluids, needles, or substances], Herpes B [handling primate bodies], Lassa fever [rodents], Lymphocytic choriomeningitis [rodents], and Rabies [contact with infected animals or their bodies])

Museum staff may be expected to take samples of substances with cotton swabs, scotch tape, or agar slides for immediate delivery to the MCEOP-designated testing laboratory for toxicity tests. If requested to take samples of mold or hazardous substances, work with the park's hazardous materials coordinator. Wear protective clothing (nitrile gloves, goggles, and a long washable smock or Tyvek jumpsuit) and an appropriately rated breathing apparatus that has been fitted to you. The MCEOP should indicate the location of testing laboratories that can identify whether the materials encountered are potentially toxic.

If high quantities of toxic substances are found in the residue (such as soot or flood mud), a professional abatement team may be required before any other work can be done. If the laboratory reports that dangerous soot, molds, or bacteria are found in excessive amounts, don't attempt to do the work with park staff. Be particularly careful when cleaning up the dried and powdered residue of floods, as this may contain asbestos particles, chemicals, molds, bacteria, excrement, and hundreds of microorganisms.

If possible, determine the source of any water or other wet contaminant (waste water from plumbing, flood waters, or rainwater), the length of exposure, the speed and type of drying, and other materials that contributed to the flood residue, such as dead animals or asbestos tiles. Your MCEOP team should include at least one team member who can interpret the laboratory report, preferably a conservator. Follow the guidance in the:

- Emergency Planning Master Worksheet (Figure 10.1)
- Risk Assessment Worksheet (Figure 10.2)
- First 48 Hours Emergency Response Checklist (Figure 10.3)

These documents are used in judging the amount of emphasis to be given to each potential type of emergency. The original information is captured on the Risk Assessment Worksheet, which includes significant planning and prevention information. The summary of this information is transferred to the Emergency Planning Master Worksheet to determine disaster priorities.

The Emergency Planning Master Worksheet tells you where to place your time and money for best effect. Once priorities have been established, use the First 48 Hours Emergency Response Checklist to determine how to proceed on a step-by-step basis. Also see the readings provided in the bibliography, particularly:

- Southeastern Registrars Association's *Steal This Handbook! A Template for Creating a Museum's Emergency Preparedness Plan*
- National Task Force on Emergency Response. *Safeguarding Our Cultural Heritage: Emergency Response and Salvage Wheel* (mailed to all parks in 1997)

E. Preparation of a Museum Component to an Emergency Operations Plan

1. *What is an MCEOP?*

Each NPS park has an Emergency Operation Plan or EOP, which indicates how emergencies will be handled to prevent them from becoming disasters. The Museum Collection Emergency Operation Plan (MCEOP) is a museum component of the EOP. This MCEOP should be simple, flexible, and current, focusing on the key actions, resources, and organizations/individuals to be involved. The MCEOP includes:

- ***job descriptions and reporting structure*** for each emergency team member (See Section E.3.)
- ***telephone tree or calling list*** of response team members and alternates (See Section E. 4.)
- ***building floor plans*** for all structures containing museum storage, work, exhibit, and research spaces (See Section E.5.)
- ***key emergency response information***, including:
 - evacuation plan
 - quick reference checklists on prevention and preparation for emergencies, including:
 - emergency security procedures
 - emergency utility shut-off procedures
 - emergency mechanical work, such as air intake valve closures (See Section E.6.)
- ***salvage procedures***
 - Emergency Planning Master Worksheet (Figure 10.1)
 - Risk Assessment Worksheet (see Figure 10.2)
 - First 48 Hours Emergency Response Checklist (Figure 10.3)
- ***list of equipment services and supplies*** (See Section E.8.)
- ***prioritized list of collections*** in paper (not electronic) format that focuses on types of materials. For example,

Water disaster:

High priorities: photographs, leather, paper, friable media, and watercolors

Moderate priorities: herbaria, textiles, iron, brass, copper

Low priorities: stone, paleontological specimens, most metals other than iron, brass, and copper

See Section D.2.

- *bibliographies* for further information (See the Bibliography.)

2. *How do I prepare the MCEOP?*

The MCEOP can be completed as a set of lists to be contained in a master set of MCEOP loose-leaf notebooks for distribution to all MCEOP team members. Some of these MCEOP notebooks should be kept at team members' homes as well as offices to ensure ready access at all times.

Keep your plan clear, simple, and flexible.

The simplest plans are the most easily executed. Complexity can delay action and discourage flexibility. Use the plan and the planning process to communicate with all the individuals you will need to have involved in the emergency recovery process. For a sample MCEOP see the Northeast Museum Services Center *Emergency Planning and Response for Museum Collections*, 2nd edition. Boston, Mass.: Northeast Museum Services Center, 1998.

Make certain the plan identifies resources and potential sources of assistance, including park, regional, and SO staff; cooperators such as regional conservation laboratories, local universities, and selected contractors; and federal, state, and county emergency support staff. Set up collaborative or contractual relationships with local universities, state and local archives, libraries, museums, and others to respond in case of emergencies. Identify the materials to be salvaged, their location, and their salvage order. Explain how to salvage them. Indicate within the MCEOP where all the supplies and equipment necessary to salvage are located.

3. *How do I determine who should be involved?*

Keep team leadership at the park level, preferably with the museum staff. Call on park staff. To determine how many people should be involved, look at the collections size, range of types and formats, vulnerabilities, salvage priorities, distribution within various structures, exhibit space, workspaces, and research spaces, as well as off-site storage. How long would it take you to evacuate the collection in case of an emergency (earthquake, fire, flood, storm, or volcano)?

Are you likely to have to move the collection to another structure or locale? This is most likely if you are in a flood plain, near a volcano, or in a similarly hazardous area. What are the environmental and security conditions of this alternate space? Where is it? How will you wrap, document, and transport collections? Your relocation need will depend upon where and how your collection is housed and the sort of collection you have. You may wish to set up a two-tier team with a core MCEOP crew and a larger disaster response support group that includes already trained volunteers and cooperators. The core park staff MCEOP team members plan for, mitigate, supervise, and manage the emergency. The larger group provides additional hands.

You are more likely to succeed at relocating herbaria that are in a volcano's path than in moving a row of cannons or large outdoor sculptures in response to a tornado alert. Exercise judgment, knowing that all collections movement

is also potentially hazardous. Collections in boxes and on shelves are easier to evacuate than those in file cabinets or exhibit cases. Boxed collections on mobile bun rack shelving can simply be rolled onto trucks, shelving unit-by-shelving unit and transported out of harms way. How many people would you need to manage the types of emergencies you are apt to experience? How fast could the work be done? Once you establish this, you can investigate the local and regional resources at your disposal for managing emergencies.

Once you determine how many people are needed, review available park staff, particularly museum staff, records managers, librarians, historians, and similar individuals who have some expertise in working with material culture. If you do not have enough park staff for an emergency response effort, ask SO and regional staff to serve. If the staffing level is still inadequate, ask cooperators for assistance, particularly nearby university personnel, state library or archives staff, and regional conservation labs. Don't forget that you will be able to call upon some selected contractors and federal, state, and county emergency support staff in your region. Meet with these individuals now, before you need them.

As you identify MCEOP team members, remember to write descriptions for each job including:

- ***MCEOP coordinator***, who supervises emergency planning, response, and mitigation and salvage measures and coordinates with all EOP personnel
- ***emergency registrar***, who manages documentation, labeling, and treatment, and orders and manages supplies/equipment availability
- ***salvage coordinator***, who manages priority identification and object salvage, packing and relocation
- ***security coordinator***, who identifies and helps manage health, safety, and collection risks, ensures security, and cooperates with park EOP coordinator on basic utility and service recovery
- ***MCEOP team members***, who undertake the basic salvage and recovery work

Lines of authority, work assignments, and actual responsibilities should be clear for all positions. Alternates should be assigned and trained for each position.

Consider setting up cooperative agreements for mutual emergency support and recovery activities. Talk to your regional curator and SO staffs about existing mutual support activities they have already established. Work with your local or regional conservation laboratory as well as state and local archives, libraries, and museums. Ensure that the names, addresses, phone and fax numbers, and e-mail addresses of all individuals involved are incorporated into your plan.

4. *What is a telephone tree?* Your telephone tree may be one of the most important documents you create. In this section of the MCEOP you will list the fire department, hospital, police department, MCEOP team members and their alternates, giving the following:

- names
- telephone numbers
- beeper numbers
- fax numbers
- e-mail address
- address
- anticipated response time
- special skills, such as photographic documentation, heavy equipment operator, paper preservation
- assigned job title for emergencies (such as salvage registrar or photographic collections salvage team leader)

The telephone tree should be set up so that each staff member is responsible for calling several others at the time of the emergency so as to free up the team leader for emergency response actions.

5. *How do I incorporate floor plans into my MCEOP?* Your MCEOP should include a full set of floor plans for all structures that house museum storage, work, exhibit, and research spaces. All floors of all structures involved, including attics and basements, should be included.

The floor plans should be appropriately annotated to indicate locations of:

- collections, with salvage priorities marked
- park records, particularly museum documentation
- electricity shut-off valves and breaker boxes
- emergency response equipment and supply caches
- evacuation routes
- fire detectors, extinguishers, and suppression equipment
- utility (gas, water, power) shut-off valves
- HVAC equipment
- alternate power source shut-off valve

- security systems
- sprinkler system shut-off valves
- water detectors/alarms
- appliances with separate shut-off valves (water heaters, stoves, etc)

Due to the complexity of this information, you may need to use a number of different plans with grouped information. For example, keep the evacuation route on one plan, the shut-off valves on another set, and the collections information on yet another.

6. *What other museum collections emergency response planning information should I include in the MCEOP?*

There are several other basic types of emergency response information you should include in the MCEOP. Include guidance on how to:

- ***standardize safety activities*** for staff and visitors during an emergency, including such steps as:
 - setting up an evacuation system and clearly marked route
 - setting up an emergency evacuation assemblage area
 - checking the evacuation route and the emergency assemblage area for potential hazards prior to evacuation
 - avoiding elevators and windows
 - holding an evacuation roll call
 - practicing fire drills and other evacuations
 - training staff how to use equipment, wear protective clothing, and undertake salvage
 - training staff how to report and handle medical emergencies
 - testing staff to ensure comprehension of all training as per OSHA requirements
 - keeping staff tetanus shots current
- ***manage emergency shut-down and lock up procedures***, such as:
 - securing doors and key control to the extent possible
 - training staff to shut-off water, electricity, and gas
 - training staff how to close doors, windows, and blinds
 - training staff how to shut down all air intake and air handling system

- **assess the damage**, including:
 - making a list of all affected spaces
 - looking for evidence of mold and insect or pest infestations
 - checking for evidence of theft
 - checking for destruction of portions of the collection
 - watching for hazardous contaminants or conditions

See Section B, Section E.7, the First 48 Hours Emergency Response Checklist (Figure 10.3), and the National Task Force on Safeguarding Our Cultural Heritage’s *Emergency Response and Salvage Wheel* for detailed descriptions of how to act, particularly during the vital first 48 hours after an emergency. Other resources in the bibliography provide specific guidance for each type of emergency.

7. *What salvage guidance should my MCEOP include?*

Your plan indicates your salvage priorities, the location of your highest priority collections, and procedures to be taken for disaster prevention, survival, mitigation, and recovery. See Sections B.2-B.13 and Figure 10.3 and the sources in the bibliography. Some specific guidance on how to handle, pack, and freeze particular types of materials may also be useful, although most of this knowledge must be gained through disaster recovery exercises rather than through readings.

When disaster strikes, recovery operations should be second nature to staff. To be comfortable, non-threatening, and routine, build your disaster recovery procedures upon routine museum activities. Train staff through hands-on activities.

8. *What information on equipment, services, and suppliers should my MCEOP include?*

List the following equipment, services, and supplies information:

- **collections salvage supplies**, such as acetone, ammonia, bleaches, blotting paper, brooms, buckets, disinfectants, clean garbage cans, dumpsters, clothes pins, garbage bags, dust pans, ethanol, fungicides, masking tape, mops, mylar, Japanese tissue paper, paper towels, plastic sheeting, polyethylene bags, plastic milk crates or records cartons, rags, rope and twine, scoops, scouring powder, scrub brushes, shovels, sponges, towels, and wax paper
- **construction materials**, such as glue, lumber, nails, paint, plywood, screws, twine, and wire
- **documentation supplies**, such as cameras, film, paper, pencils, tripods, videotape camera and videotapes, a portable computer printer, and portable computers with ANCS+

- **emergency equipment**, such as air compressors, many batteries, battery-powered weather band radios, blotters, cellular phone, clothes pins, extension cords, flashlights, hoses, knives, ladders, portable lights, portable tables, polyurethane ice chests, rope, sand bags, pumps, scissors, shovels, squeegees, tools, tarps, tents, weights, such as glass bricks, and wet/dry vacuum cleaners. **Note:** Store copies of appropriate equipment manuals with the equipment.
- **emergency work areas and safe storage areas**, including their location, amount and type of space, security measures, and local contact person's name and number
- **environmental equipment**, such as dataloggers, dehumidifiers, fans, hygrometers, and space heaters
- **first aid equipment**, such as blankets, burn packs, first aid kits, resuscitator, stretcher, and 3-4 days of clean water. **Note:** You don't need to stockpile perishable supplies. Instead, identify commercial suppliers and make arrangements for rapid delivery of items during an emergency.
- **hand tools**, such as axes, block and tackle, bolt cutters, chain saws, crowbars, hammers, pliers, ropes, saws, screwdrivers, sledge hammers, staple guns, staples, tape measurers, tin snips, utility knives, wire cutters, wood saws, and wrenches
- **off-site salvage equipment and supplier list**, including the supplier location, telephone number, contract or cooperative agreement number or purchasing arrangements, and the contact person's name and telephone numbers for:
 - architects
 - building contractors
 - carpenters
 - chemical testing laboratories
 - cleaning services
 - commercial cold storage vaults
 - computer data recovery services
 - conservation treatment services
 - dehumidification services
 - electricians
 - environmental control services
 - fumigation services
 - glaziers
 - HVAC services
 - mycologists
 - photographic salvage and/or reprocessing services
 - plumbers
 - portable equipment suppliers
 - scientific monitoring equipment suppliers
 - security services
 - transportation rental (including freezer trucks)

- **planning tools**, such as battery-operated portable computers and calculators
- **protective clothing**, such as dust masks, fitted breathing apparatuses with cartridges for mold, goggles, life vests, nitrile gloves, old wool sweaters, rubber aprons and boots, safety goggles. **Note:** Some of this equipment must be specially fitted to the individual team member and requires training to use properly.

9. *What kinds of references should I include in the bibliography?*

Include key references from the bibliography at the end of this chapter. In particular, include:

- Southeastern Registrars Association's *Steal This Handbook! A Template for Creating a Museum's Emergency Preparedness Plan*
- National Task Force on Emergency Response. *Safeguarding Our Cultural Heritage: Emergency Response and Salvage Wheel*. (mailed to all parks in 1997)

F. Staff Training and Plan Evaluation and Revision

Train your entire emergency operations team, not just the park staff, to manage the various types of emergencies. The entire team must know each other, be capable of working together efficiently, and be aware of the authority lines within the team. Roles, responsibilities, and reporting structure must be absolutely clear. It is essential that work not be slowed because of operational disagreements or need for contracts or approval for activities. What will be done, how it will be done, and when it will be done must be agreed upon before you begin emergency preparations or salvage.

1. *How do I guarantee my team's efficiency and confidence?*

Don't wait until a disaster happens to begin training exercises. Train, train, and train again! Give the entire team some hands-on training together before you experience problems. Stage simulated disasters in cooperation with other local agencies. Many professional organizations train staff in disaster recovery through use of actual disposable materials. These simulated disasters are the ideal training ground.

While your MCEOP will be helpful, it will not teach your team how to handle wet textiles, charred documents, or metals affected by volcanic ash. Your team's efficiency will only be as good as that of the team's weakest member. Whenever a team member leaves or is replaced, train the entire team again. The team must know exactly what to do without having to think about it. Speed is essential, as is actual hands-on expertise.

2. *How do I prevent panic and ensure the health and safety of staff?*

Write your MCEOP now. Begin training your emergency team today. Don't wait! When training staff, make certain that they know that their health and safety are the most important measures of the success of the emergency plan.

Personal safety comes first, collections safety second.

To achieve staff safety, emergency team members must remain calm and alert, aware of potential dangers such as gas, electrical utility lines, loose asbestos, disease risks, contaminated water, mold, and so forth. A panicked team is useless.

3. *What role does the team leader play?*

The team leader's leadership qualities are a crucial factor in team capabilities and efficiency. An uncertain or squeamish emergency team leader can be disastrous. The first 48 hours of response time are crucial for determining what is salvaged. If major mistakes are made during the first 48 hours, many of them will be irreversible.

The team leader is ultimately responsible for:

- team composition—who serves, who remains on the team, and who doesn't
- job assignments and reporting structure on the team
- frequency of team meetings
- team performance
- team expenses
- museum component of the EOP—development, review, and updating
- training and testing team members, including drills, simulations and tests for safety in all types of emergencies
- critiquing and offering feedback on training exercises
- setting up all outside contacts, such as with the local fire and police departments and the Red Cross
- convincing park staff of the importance of the effort
- ensuring team safety, including identifying structural stability, electrical system damage, leaking gas, raw sewage leaks, mold problems, disease risks, and similar problems that must be solved before work can proceed on site
- determining when salvage must stop due to safety concerns or materials to be salvaged must be removed by HAZMAT specialists to a safe workspace
- pulling together all the necessary supplies, services, contractors, equipment, and participants
- determining salvage priorities without seeking further authorizations, if they are not readily obtainable
- ensuring that the team has all the information and training necessary to make the right decisions

- keeping the plan up to date and distributing updated copies as changes are made
 - maintaining a list of plan holders
4. *Who should evaluate the emergency operations plan?* Everyone, particularly all emergency operation team members, should evaluate the plan.
5. *How do I keep the plan current?* As you train staff you will find errors or changes you wish to make to the plan. Comments should be provided to the team leader. The team leader should establish a regular review period, preferably about every six months, but at least annually, for updating and revising the plan. Specific events may lead to a need to reissue the plan, such as changes in staff or telephone numbers, development of new park hazards and vulnerabilities, major new equipment, new cooperative relationships, and new park capabilities.
- Once evaluated and revised, the new plan must be sent out to all emergency team members, preferably in duplicate so that they have copies for both office and home. The revised plan should be accompanied by a “Record of Amendments and Changes” sheet to alert staff to changed text. Old pages should be replaced with new ones when team members receive the revised pages.
6. *Summary* Personal and team safety is the top priority of all salvage efforts. Once safety is ensured through proper training, the second priority is disaster prevention through risk assessment and mitigation activities. Preservation and disaster prevention always trump disaster recovery. Finally, disaster recovery is a team effort that builds on careful planning, prioritization, team-building, and hands-on experience, as well as on the ability to rapidly and calmly respond in the face of emergencies.

G. Bibliography

General:

- Allyn, Lord, Carolyn Reno, and Marie Demeroukas. *Steal This Handbook! A Template for Creating a Museum's Emergency Preparedness Plan*. Columbia, S.C.: Southeastern Registrars Association, 1994.
- Barton, John P., and Johanna G. Wellheiser, eds. *An Ounce of Prevention: A Handbook on Disaster Contingency Planning for Archives, Libraries, and Record Centers*. Toronto: Toronto Area Archivists Group Education Foundation, 1985.
- Buchanan, Sally. “Disaster Prevention, Preparedness, and Action.” *Library Trends* 30 (2, 1981): 241-53.
- Coleman, Christopher. “Practical Large-Scale Disaster Planning.” *Westwords* 2 (May 1992): 1-20.
- Fortson, Judith. *Disaster Planning and Recovery: A How-To-Do-It Manual for Librarians and Archivists*. New York: Neal Schuman Publishers, 1992.
- Fox, Lisa L. “Management Strategies for Disaster Preparedness.” *ALA Yearbook of Library and Information Services* 14 (1989): 1-6.

- Gennelly, Lawrence. J. *Museum, Archives, and Library Security*. Stoneham, Mass.: Butterworth Publisher, 1983.
- Gallery Association of New York State. *Insurance and Risk Management for Museums and Historic Societies*. Hamilton, N.H.: Gallery Association of New York State, 1985.
- Grant, Joan, Barbara Jones, Nancy Kranish, and Janice Maiman, eds. *Disaster Plan Workbook*. New York: New York University, Elmer Holmes Bobst Library, 1984.
- Hendriks, Klaus B., and Brian Lesser. "Disaster Preparedness and Recovery: Photographic Materials." *The American Archivist* 46, no. 1 (Winter 1983): pp 52-68.
- Jones, Barclay G., ed. *Protecting Historic Architecture and Museum Collections from Natural Disasters*. Stoneham, Mass.: Butterworth Publishers, 1986.
- Meister, Pamela, ed. *Southeastern Museums Conference 1991 Disaster Preparedness Seminar Proceedings*. No location given. 1991.
- Murray, Toby. "Disaster Preparedness: A Checklist." *Technical Bulletin* 2. Oklahoma Field Advisory Service: (October 1989)
- Myers, James N., and Denise D. Bedford, eds. *Disasters: Prevention and Coping*. Proceedings of the Conference, 21-22 May 1980. Stanford, Calif.: Stanford Universities Libraries, 1981.
- National Task Force on Emergency Response. *Safeguarding Our Cultural Heritage: Emergency Response and Salvage Wheel*. Washington, D.C.: National Institute for the Conservation of Cultural Property, Inc., 1997.
- Norris, Debra Hess. *Disaster Recovery: Salvaging Photograph Collections*. Philadelphia: Conservation Center for Art and Historic Artifacts, 1998.
- O'Connell, Mildred. "Disaster Planning: Writing and Implementing Plans for Collections-Holding Institutions." *Technology & Conservation* (Summer 1983): 18-26.
- Ogden, Sherelyn. *Preservation of Library & Archival Materials: A Manual*. Andover, Mass: Northeast Document Conservation Center, 1994.
- Rhodes, Barbara J. *Hell and Highwater: A Disaster Information Sourcebook*. New York: METRO Misc. Pub. 35: New York Metropolitan Reference and Research Libraries (METRO), 1988, 58 pp.
- Sable, Martin H. *The Protection of the Library and Archive: An International Bibliography*. New York: Haworth Press, 1983. Reprinted from *Library & Archival Security* 5 (Summer/Fall 1983)
- Special Libraries Association. *Disaster Planning and Recovery: An SLA Information Kit*. Washington D.C.: SLA, 1989.
- United States Department of the Interior: Bureau of Land Management. "Disaster Recovery Plan for Paper and Film Records." *BLM Manual Handbook* 1273-1. Washington, D.C.: Bureau of Land Management, 1988.

Earthquakes:

- Agbabian, M.F. Masri, and R.L. Nigbor. "Evaluation of Seismic Migration Measures for Art Objects." *Getty Conservation Institute Scientific Program Report* (January 1990).
- Algermissen, S.T. *An Introduction to the Seismicity of the United States*. Buffalo, N.Y.: State University of New York, 1983.

Bosai, Elmer E., Alfred Goldberg, John L. Fisher, Henry J. Lagorio, and Thomas D. Wosser. *Architects and Earthquakes*. Washington, D.C.: American Institute of Architects, 1987.

Federal Emergency Management Agency. *Earthquake Preparedness and Public Information Materials: An Annotated Bibliography*. Earthquake Reduction Series. Washington, D.C.: FEMA.

Jacob, Klaus H., and Carl Turkstra, eds. "Earthquake Hazards and the Design of Constructed Facilities in the Eastern United States." *Annals of the New York Academy of Sciences*. New York: New York Academy of Sciences, 1989.

Stover, Carl W., and Jerry L. Coffman. *Seismicity of the United States, 1568-1989*. (rev.) Washington, D.C.: USGS, Professional Paper 1527.

Note: Also call the USGS Earth Science Information Center at 415-329-4390.

Explosions:

Federal Bureau of Alcohol, Tobacco, and Firearms. *Federal Firearms Regulations Reference Guide*. ATF P5300.4; Washington, D.C.: Federal Bureau of Alcohol, Tobacco, and Firearms, n.d..

_____. *ATF Explosives Laws and Regulations*. ATF P5400.7; Washington, D.C.: Federal Bureau of Alcohol, Tobacco, and Firearms, n.d.

Fire:

Advisory Council on Historic Preservation. *Fire Safety Retrofitting in Historic Buildings*. Washington, D.C.: Advisory Council on Historic Preservation and General Services Administration, 1989.

Artim, Nicholas. "Cultural Heritage Fire Suppression Systems: Alternatives to Halon 1301." *WAAC Newsletter* 15/2 (May 1993): 34-36.

McKinnon, Gordon P. *Fire Protection Handbook*. Boston: National Fire Protection Association, 1976.

Morris, John. *The Library Disaster Preparedness Handbook*. Chicago and London: American Library Association, 1986.

Morris, John. *Managing the Library Fire Risk*. 2nd ed. Berkeley, Calif.: University of California, 1979.

National Fire Protection Association. *NFPA 909: Standard for the Protection of Cultural Resources including Museums, Libraries, Places of Worship, and Historic Properties*. Quincy, Mass.: National Fire Protection Association, 1997.

National Fire Protection Association. *NFPA 232A: Guide for Fire Protection of Archives and Records Center*. Quincy, Mass.: National Fire Protection Association, 1995.

Trinkley, Michael. "Can You Stand the Heat? A Fire Safety Primer for Libraries, Archives and Museums." Atlanta: *SOLINET*, 1991/1992.

Wilson, J. Andrew. "Fire Fighters." *Museum News* (November/December 1989): 68-72.

Flood:

Eulenberg, Julia Niebuhr. *Handbook for the Recovery of Water Damaged Business Records*. Prairie Village, Kans.: Association of Records Managers and Administrators, 1986.

Martin, John H., ed. *The Corning Flood: Museum Underwater*. Corning, N.Y.: The Corning Museum of Glass, 1977.

Nyberg, Sandra. "The Invasion of the Giant Spore." *SOLINET Preservation Program Leaflet*, no. 5. Atlanta: Southeastern Library Network, 1987.

Walsh, Betty. "Salvage Operations for Water-Damaged Collections." *Western Association for Art Conservation Newsletter* 10, no. 2 (May 1988).

Waters, Peter. *Procedures for Salvage of Water-Damaged Library Materials*. 2nd ed. Washington, D.C.: Library of Congress, 1979.

Storms:

Bomar, George. *Texas Weather*. Austin, Tex.: University of Texas Press, 1983.

Mathieson, David F. "Hurricane Preparedness: Establish Workable Policies for Dealing with Storm Threats." *Technology and Conservation* (Summer 1983): 28-29.

Trinkley, Michael. *Hurricane! Surviving the Big One: A Primer for Libraries, Museums, and Archives*. Atlanta: Southeastern Library Network, Inc. (SOLINET), 1993.

Structural Collapse:

Frens, Dale H. "Temporary Protection: Specifying Temporary Protection of Historic Interiors During Construction and Repair." *Preservation Tech Notes*, no. 2. Washington D.C.: National Park Service, 1993.

Volcanoes:

Simkin, Tom, and Lee Siebert. *Volcanoes of the World*. Tucson, Ariz.: GeoScience Press, 1994.

McClelland, L., T. Simkin, M. Summers, E. Nielsen, and T. Stein. *Global Volcanism, 1975-1985*. Washington, D.C.: Smithsonian Institution, 1993.

Web Resources:

Computer-Aided Management of Emergency Operations (CAMEO®):
<<http://www.epa.gov/ceppo/cameo/index.htm>>.

Department of Homeland Security: <<http://www.dhs.gov>>.

Disaster Recovery Journal: <<http://www.drj.com>> via e-mail at drj@drj.com article and chat forum user name: drj; password: world; questions to eab@drj.com.

Disaster Resource Guide: <<http://www.disaster-resource.com/>>.

Disaster Recovery for Records Managers: <<http://www.system.missouri.edu/records/disaster.html>>.

Earthwatch Storm Watch: <<http://www.earthwatch.com/STORMWATCH/stormwatch.html>>.

FEMA: <<http://www.fema.gov>>.

Floodcast: <<http://www.earthsat.com/flood/floodcast.html>>.

International Foundation for Cultural Property Protection: <<http://www.ifcpp.org>>.

National Earthquake Information Center: <<http://wwwneic.cr.usgs.gov/eqlists/eqstats.html>>.

National Fire Protection Association: <<http://www.nfpa.org>> or call 1-800-344-3555.

NIOSH: <<http://www.cdc.gov/niosh/flood.html>>.

NOAA Storm and Flood Warnings: <<http://iwin.nws.noaa.gov/iwin/nationalwarnings.html>>.

Resource: The Council for Museums, Archives and Libraries, "Managing Risk":
<<http://www.resource.gov.uk/action/managingrisk/managingrisk.asp>>.

Volcano World Volcano Index: <http://volcano.und.nodak.edu/vwdocs/volc_images/sorted_by_country.html>.

Worldwide Connection for Audit, Security, Control and Euro Project Professionals:
<<http://www.auditserve.com/>>.

H. List of Figures

Figure 10.1a.	Emergency Planning Master Worksheet.....	10:58
Figure 10.1b.	Sample Completed Emergency Planning Master Worksheet	10:59
Figure 10.2.	Risk Assessment Worksheet.....	10:61
Figure 10.3.	First 48 Hours Emergency Response Checklist	10:72

Facility Name:

Emergency	Prioritize Emergencies*	Reminder of Key Mitigation Actions Necessary	Reminder of Key Mitigation Actions Already Taken
Fire			
Flood and Water Damage			
Storms			
Medical Emergency			
Utility Failure			
Accident (Hazardous Material)			
Accident (Transportation)			
Civil Unrest and Terrorism			
Explosions and Bombs			
Earthquakes and Structural Collapse			
Volcanoes (includes Mudslides)			
Other (please specify)			
Other (Please specify)			
Other (Please specify)			
Other (Please specify)			

*Use numbers from 1 (most likely) to 12 (least likely) based upon conversations with long-term staff and upon research. Also consider the “no” responses on the Risk Assessment Worksheet (Figure 10.2). A large number of “no” responses for a particular emergency (e.g., fire) can mean a higher risk for an emergency to become a disaster.

Figure 10.1a. Emergency Planning Master Worksheet

Facility Name: Stayer Bldg, YAPI

Emergency	Prioritize Emergencies*	Reminder of Key Mitigation Actions Necessary	Reminder of Key Mitigation Actions Already Taken
Fire	1	<ol style="list-style-type: none"> 1. Remove nitrate negatives from museum storage, copy, and place in off-site storage 2. Remove stove from curatorial work space. 3. Have shrubs removed from front of building. 4. Obtain back-up power source for fire alarms, detectors, and suppression system. 	<ol style="list-style-type: none"> 1. Done on 5/9/99. 2. To be done on 11/15/99 3. Done on 9/9/99. 4. To be done on 11/23/99
Flood and Water Damage	2	<ol style="list-style-type: none"> 1. Relocate collections from basement to 2nd floor. 2. Fix drainage near footings. 3. Replace roof. 4. Install water detectors. 5. Clear gutters and downspouts every 4 months. 6. When selecting new furniture, select metal. 7. When refinishing space, choose tile and paint. 	<ol style="list-style-type: none"> 1. Done on 10/18/99 2. Begun on 10/30/99; due to be done on 12/15/99 3. Due to be done in Spring 2000 4. Done on 6/8/99 5. On maintenance schedule; being done regularly. 6. Due to be done in Fall 2000. 7. Due to be done in Spring 2001.
Storms	5	<ol style="list-style-type: none"> 1. Repair building structural seals around windows, doors, etc. 2. Purchase weather band radios. 3. Teach staff how to secure and shut down the building. 4. Bolt furniture to walls. 5. Check to see if near-by utility line can be moved. 	<ol style="list-style-type: none"> 1. On maintenance schedule for Fall 1999. 2. Done 5/10/99. 3. Done 4/30/99. 4. Scheduled for Fall 1999. 5. Proposed to Maintenance on 6/30/99; awaiting a decision.
Medical Emergency	6	<ol style="list-style-type: none"> 1. Train museum staff in identification of health and safety hazards. 2. Train one staff member in hazardous waste management and basic CPR. 3. Purchase first aid kits. 	<ol style="list-style-type: none"> 1. To be done on 9/5/99 at the Curatorial Retreat 2. To be done at specialized workshops in May and June of 1999. 3. Done on 2/1/99.
Utility Failure	4	<ol style="list-style-type: none"> 1. Arrange for back-up power source for security, emergency lighting, and HVAC. 2. Move boxes away from back door to free up the emergency exit. 3. Teach staff how to shut down and evacuate the building. 	<ol style="list-style-type: none"> 1. On RMP projects list as of 8/15/99. 2. Scheduled to be done by maintenance on 7/30/99. 3. Scheduled for regional collections management retreat on 4/15/99.

*Use numbers from 1 (most likely) to 12 (least likely) based upon conversations with long-term staff and upon research. Also consider the “no” responses on the Risk Assessment Worksheet (Figure 10.2). A large number of “no” responses for a particular emergency (e.g., fire) can mean a higher risk for an emergency to become a disaster.

Figure 10.1b. Sample Completed Emergency Planning Master Worksheet

Facility Name: Stayer Bldg, YAPI

Emergency	Prioritize Emergencies*	Reminder of Key Mitigation Actions Necessary	Reminder of Key Mitigation Actions Already Taken
Accident (Hazardous Material)	7	Will be addressed in 1999.	
Accident (Transportation)	10	Will be addressed in 2002.	
Civil Unrest and Terrorism	9	Will be addressed in 2001.	
Explosions and Bombs	8	Will be addressed in 2000.	
Earthquakes and Structural Collapse	3	<ol style="list-style-type: none"> 1. Museum storage cabinets and shelving must be attached to structural walls and braced with steel cross-braces. 2. All glass, ceramic, and ivory items need to be cavity packed in hollowed-out blocks of polyethylene and labeled. 3. Framed artwork should be placed on storage screens with steel "S" hooks. 4. Plexiglass exhibit cases and furniture should be purchased and used. 5. Museum cabinet drawers should be lined with polyethylene foam (except for some NH items). 	<ol style="list-style-type: none"> 1. Done on 7/16/99. 2. Done on 8/19/99. 3. Scheduled for implementation on 10/5/99 by curation and interpretation units. 4. Scheduled for replacement in January 2000 by HFC. 5. Done on 4/15/99.
Volcanoes (includes Mudslides)	12	Will be dealt with in 2004	
Other (Please specify) <i>Nuclear Meltdown and Radiation</i>	11	Will be done in 2003.	

*Use numbers from 1 (most likely) to 12 (least likely) based upon conversations with long-term staff and upon research. Also consider the "no" responses on the Risk Assessment Worksheet (Figure 10.2). A large number of "no" responses for a particular emergency (e.g., fire) can mean a higher risk for an emergency to become a disaster.

Figure 10.1b. Sample Completed Emergency Planning Master Worksheet (continued)

First 48 Hours Emergency Response Checklist	
Responsible Person	Activity
Team Leader	<p>Immediately Prior to Emergency, Plan and Prepare:</p> <ul style="list-style-type: none"> • Monitor emergency warnings and watches on radio, television, and Web sites. • Check to ensure that alarms for water, fire, and back-up power systems are working. • Check evacuation route to ensure all doors are unblocked and the route is clearly marked. • Keep in touch with authorities. • Prepare to implement MCEOP plan. • Alert MCEOP team to stand-by for emergency recovery. • Check supplies and equipment caches and back-up power sources. • Move collections to safer storage, if possible, such as to higher ground. • Follow appropriate guidance in Section B.2-13 under the appropriate type of emergency (fire or flood) and the categories “Prevention,” “Warnings,” and “Watches.”
Team Leader	<p>When Emergency Strikes, Ensure Staff, Visitor, and Collections Survival:</p> <ul style="list-style-type: none"> • Check the evacuation route for safety, then evacuate the building. Evacuate early enough so that individuals won’t be stranded. • Send all individuals to a single assembly site without using the elevators. • Shut down the building as you evacuate (Team Leader and Assistant): <ul style="list-style-type: none"> – Close doors, blinds, storm shutters, and windows as you leave – Check elevators and stairwells for trapped individuals – Turn off utilities (water, electricity, and gas) at the mains • If your safety is not compromised, deal with manageable emergencies as you evacuate (use a handheld fire extinguisher on a trash can fire, plastic wrap items near a roof leak). • Hold an evacuation roll call to ensure that all individuals have evacuated safely. • Notify appropriate authorities, including the park chain of command and the external emergency authorities such as the Fire Department of any missing individuals and of the emergency situation. • Notify the park public relations officers of the emergency so that they are ready to field public and news inquiries. • Follow guidance in Section B.2-13 under “survival” for the appropriate type of emergency and in your MCEOP plan. Start Telephone Tree calls to all MCEOP team members. Alert them to await notification to come to the park for salvage team work.
Team Leader, EOP head, and Maintenance Liaison	<p>Following an Emergency, Assess the Situation.</p> <ul style="list-style-type: none"> • Notify regional emergency officials including FEMA, regional, and SO Staff. • Determine the level of risk for MCEOP staff to begin salvage: <ul style="list-style-type: none"> – Test unknown substances for toxicity via a professional laboratory. – Check structural stability to ensure floors, walls, and stairs are safe. – Check for utility problems, which may pose life-threatening situations. – Watch for potential biological hazards, such as mold or snakes due to flood waters. Mold may require laboratory analysis to ensure it is not deadly. – Check for other contaminants, such as asbestos, gasoline, chemicals, and radiation. These materials may require laboratory analysis for toxicity. – Work with Maintenance Liaison, the park structural engineer, and EOP coordinator to determine if it is safe for MCEOP Team to proceed with salvage. – Check the route to the park or center to ensure that it is safe for team arrival. – Ensure that the salvage site meets OSHA standards for worker safety. If so, proceed by notifying the MCEOP team to assemble. • If the site doesn’t meet OSHA standards, hire HAZMAT or other professional salvage personnel who are rated to work under the existing conditions. • Contact necessary contractors and service providers to be ready to provide help.

Figure 10.3. First 48 Hours Emergency Response Checklist

First 48 Hours Emergency Response Checklist	
Responsible Person	Activity
MCEOP Team and Team Leader	<p>Get Coordinated:</p> <ul style="list-style-type: none"> • Set up emergency escape routes (two escape routes are necessary per area according to OSHA), rest rooms (including washing facilities), water sources, staff clean-up areas, rest spaces, and eating spaces. • Ensure that medical equipment and expertise is available nearby. • Make a list of all affected spaces and identify type and level of damage. • Assemble the MCEOP team. Individuals should wear appropriate clothing, and shoes, and bring fresh water, food, and any other necessary supplies. • Assemble necessary tools and supplies. • Ensure that each staff member has all necessary protective equipment and a current copy of the MCEOP. Remind staff of health and safety concerns. • Obtain priorities for salvage among the buildings, floors, spaces, types of collections, and groups of items affected based upon the priorities listed in the MCEOP from the team leader. The team leader uses the salvage priorities coding during decision-making. • Review the lines of command during the salvage operation. • Review the handling instructions, such as: <ul style="list-style-type: none"> – assemble pieces of broken objects – handle weak or damaged objects using supports – keep handling to a minimum – be careful not to transfer contaminants to your face and hair by touching • Obtain assignments from team leader. • Schedule work breaks and identify when to go for meals and down-time. • Identify work teams and remind team members of priorities for salvage and crucial issues during handling and preparation. • Prepare work stations for the various types of activities necessary for salvage, such as: <ul style="list-style-type: none"> – rinsing stations with clean running water and sponges – air-drying stations using clothes lines and plastic or rust-proof bakers racks – interleaving stations with portable metal work tables wrapped in paper – wrapping stations where materials can be boxed for transportation to cold storage – vacuum freeze-drying, or vacuum drying stations off-site – cover all work surfaces with polyethylene • Provide on-site dehumidification for pumping very dry air into the building to dry paper, books, and carpeting, wallboard, and furnishings. <i>Note:</i> Don't use this for historic structures or general museum collections. • Document the level of damage found photographically or using a video camera. • Set up a mobile communications system including walkie-talkies and/or cellular phones. • Allocate equipment and supplies.
MCEOP team and cooperators who are fully trained.	<p>Stabilize the Structural Environment:</p> <ul style="list-style-type: none"> • Remove standing water and contaminants to the extent possible as speedily as possible. • Set-up environmental controls as soon as the Maintenance Liaison judges that the electricity can be turned on again and the controls may be used safely. • Follow the <i>Secretary of the Interior's Standards for Treatment of Historic Properties</i> during work, although it may be necessary to remove carpeting, wallpaper, and wood furniture if they are holding water, hazardous chemicals, or biological contaminants, or are moldy. Ask for assistance from the park's cultural resource manager if you are uncertain how to proceed. • Set up good security including locking doors and key control to the extent possible. • Set up good air circulation and ventilation in all spaces where you will work.

Figure 10.3. First 48 Hours Emergency Response Checklist (continued)

First 48 Hours Emergency Response Checklist	
Responsible Person	Activity
MCEOP team	<p>Begin Salvage:</p> <ul style="list-style-type: none"> • Have a conservator on hand to answer questions. • Have a toxic waste disposal contractor available to remove old chemicals, unidentified or unlabeled substances, asbestos, lead paint waste, and similar items. • Have a professional waste handler on hand to remove animal and human waste, mold, dead animals, and medical waste. • Work on high priority collections first, based upon your coded tags. • If an item can't be dried in 48 hours, freeze it unless it is glass, metal, furniture, or photographic. Consult conservators and your MCEOP about what may and may not be frozen. • Do the minimum of work possible per item. Save as much as possible. • Don't attempt complex cleaning or treatment procedures during salvage. Instead transfer the materials to a conservator or stabilize items by drying them and removing them from immediate danger. • Document all work done via a disaster registration process, so that appropriate records of transfers to cold storage, conservation, and so forth can go into the museum records. • Handle objects carefully. • Where possible, work in teams. • Use the gentlest action possible, for example use an air bulb over canned air for cleaning fragile surfaces. Work from the center towards the edges.
MCEOP team	<p>Fire Damage:</p> <ul style="list-style-type: none"> • Avoid moving sooty, smoky, or fire-damaged objects without nitrile gloves and a rated breathing apparatus that has been fitted to the user for smoke and soot. Soot is carcinogenic, so be very, very cautious. • If the fire involved burning pesticide treated wood (often green in color) the soot will be highly hazardous. Use rated breathing apparatus and gloves when working nearby. • Don't touch metallic, gilded, stone or other heat absorptive items soon after a fire. They may still be hot. • Don't try to clean sooty, smoky, or fire damaged objects. Simply remove them to a conservator's care.
MCEOP team	<p>Flood Damage:</p> <ul style="list-style-type: none"> • Lower the humidity by: <ul style="list-style-type: none"> – Pumping out the water – Using dehumidifiers and room desiccants • Lower the temperature as low as the workers can handle • Improve the air circulation by opening windows and using fans. • Keep the lights on to discourage mold growth. • Remove the wettest high priority objects first to bring the humidity down. • Use a moisture meter or visual testing to determine if items are wet or damp in order to determine how best to stabilize the items. • Move wet objects in safe and sturdy containers such as polyethylene boxes with air holes poked in the bottom to encourage drainage. • Be extremely cautious in the presence of mold: <ul style="list-style-type: none"> – separate moldy objects from others and move them into cold storage until they can be treated. – avoid blotting moldy objects as you may drive the mold spores deeper or spread them. – always wear nitrile gloves and a rated breathing apparatus when working with mold

Figure 10.3. First 48 Hours Emergency Response Checklist (continued)

First 48 Hours Emergency Response Checklist	
Responsible Person	Activity
MCEOP team	<p>Flood Damage (continued):</p> <ul style="list-style-type: none"> • Air dry animal skins, baskets, bone, books, botanical specimens, ceramics, film, framed art work, furniture, geological specimens, glass plates, ivory, leather, magnetic media, metal, photographs, paper, stone, textiles, wooden objects, and so forth at <70°F and < 50% R.H. For detailed instructions see the National Task Force on Emergency Response <i>Emergency Response and Salvage Wheel</i>. • Use fans and room desiccants such as Damp Rid® to keep the humidity down when you are air drying items, but don't use heat sources such as portable heaters, to hasten the drying. Don't allow breezes to blow directly on objects. • Use wax paper, freezer paper, aluminum foil, silicone paper, or polyethylene sheets to keep objects from sticking to each other. • Use unprinted blotting paper, lint-free towels, or unprinted newsprint to interleave/blot items. Don't reuse dirty blotting materials except for the towels that must be washed in a fungicidal detergent and thoroughly dried before reuse. • If you can't air dry an item within 48 hours; place it in cold storage. Blast freezing at -20°F or less will cause the least damage to objects. • Don't blast freeze or place in a freezer magnetic media, glass plates, glass, historic wooden furniture, ceramics, stone, paintings, geological specimens, bone, shell, ivory, paleontological specimens, or metal. Air-dry these items. • Wrap and pack items for cold storage. Label every box. Keep wet materials separate from damp materials, but do not destroy the original order and provenance to do so. • If you have a lot of flood-damaged items, hire a freezer truck to transport them. Otherwise temporarily use a home freezer, or dry ice (should not touch the materials). • If a single dead mouse or bird or their nest or waste is discovered, only trained staff should deal with the materials wearing nitrile gloves, splash goggles, and a rated breathing apparatus to avoid contracting disease. • For detailed instructions on cleaning, packing, and drying, see the sources in the bibliography.

Figure 10.3. First 48 Hours Emergency Response Checklist (continued)

Chapter 11: Curatorial Health and Safety

A. Overview	11:1
What information will I find in this chapter?	11:1
What kinds of health and safety hazards will I find in museum collections?	11:1
What is the goal of a health and safety program?	11:2
What are the general categories of occupational hazards?	11:2
B. Understanding Health and Safety Issues	11:3
What basic occupational health concepts should I understand?	11:3
How will I know that I am being exposed to hazardous materials?	11:4
How does the body absorb substances?	11:4
How do I evaluate the degree of a health hazard?	11:4
What is the Job Hazard Analysis?	11:5
C. Controlling Exposure to Hazardous Substances	11:6
How do I control exposure to hazardous substances in the workplace?	11:6
How do I limit the use of hazardous material?	11:7
What kinds of ventilation systems are available?	11:7
How do I install proper ventilation?	11:8
When should I wear Personal Protective Equipment (PPE)?	11:8
What are respiratory protective devices?	11:9
How do I select a respirator?	11:9
How do I know which gloves to wear?	11:10
What good housekeeping and personal hygiene habits do I need to develop?	11:10
How do I store, handle, and label hazardous material?	11:10
How do I dispose of hazardous waste?	11:10
D. Hazardous Chemicals and Materials Used in Collections Care	11:11
What solvents are used regularly?	11:11
What fumigants and other pesticides do museums use?	11:12
What should I know about pesticide use?	11:12
Are there special precautions for using silica gel in exhibition and storage cases?	11:13
What is the Hazard Communication Standard?	11:14
What is a Material Safety Data Sheet (MSDS)?	11:14
How do I get and maintain a MSDS?	11:15
How should I label hazardous substances?	11:15
What is the NFPA Hazard Symbol?	11:16
How can I get occupational safety and health training?	11:16
E. Hazardous Objects in Collections	11:17
What type of hazardous objects are in collections?	11:17
Why should I be concerned about pesticide residues in biological specimens and organic ethnographic and historic objects?	11:17
What do I do if I have specimens contaminated with arsenic?	11:18
How do I identify specimens that are contaminated with arsenic?	11:18
What hazards will I find in geological collections?	11:19
Why are cellulose nitrate and diacetate negatives hazardous?	11:20
How can I protect myself when working with cellulose nitrate and acetate film?	11:20
What particular concerns should I have with archival records?	11:21
What do I need to know about firearms and live ammunition?	11:21
What do I need to know about small arms ammunition?	11:22
What do I need to know about unexploded munitions?	11:23

What types of hazardous medical objects and drugs/chemicals are in collections?.....	11:23
What should I do with medical objects and drugs/chemicals?.....	11:24
What should I do with original containers?.....	11:25
F. Safety Rules for Lifting and Carrying	11:26
How should I plan for lifting and moving objects?	11:26
How do I lift and carry an object safely?	11:27
How do I reach for an object safely?.....	11:27
G. Workspace Conditions	11:27
What makes a safe and healthy curatorial workspace?	11:27
When should I worry about radon?	11:27
How do I know if there is radon in my workspace?.....	11:28
What do I do if there is a radon problem in the workspace?.....	11:28
H. Glossary*	11:29
I. Web Resources	11:30
J. Selected Bibliography	11:31
K. List of Figures	11:33

CHAPTER 11: CURATORIAL HEALTH AND SAFETY

A. Overview

1. *What information will I find in this chapter?*

This chapter has information on occupational health and safety hazards that are unique to the museum work environment. You will find guidance to assist you in ensuring a healthful and safe curatorial environment.

Appendix H has additional information on laws, regulations, policies, and guidelines on the NPS health and safety program.

Review other chapters in this handbook that contain important health and safety information including:

- Chapter 9: Museum Collections Security and Fire Protection, for information on fire safety
- Chapter 7: Museum Collections Storage, for information on structural floor load limits
- Appendix M: Management of Cellulose Nitrate and Cellulose Ester Film, for information on hazards from deteriorating historic film.

2. *What kinds of health and safety hazards will I find in museum collections?*

When you work with museum collections, you may face a wide variety of potential health and safety hazards, including:

- hazardous materials used in collections care:
 - toxic and flammable solvents, such as solvents in waxes or lacquers
 - preservatives, such as alcohol and formalin, used for storing natural history specimens
 - pesticides used to kill or discourage pests
- hazardous objects and conditions in collections
 - pesticide residues from past treatment of collections, such as arsenic
 - objects with inherent vice such as unexploded ordnance or cellulose nitrate film
 - biological hazards such as mold, hantavirus, and insects/arachnids
 - sharp or broken edges on objects

You may also create safety hazards through carelessness in handling collections and supplies (for example, careless lifting and carrying).

You need to know your own susceptibility to allergens and irritants (for example, bee stings or dust) and take appropriate precautions.

You need to acquaint yourself with typical hazards and how you can ensure a healthful and safe curatorial environment.

3. *What is the goal of a health and safety program?*

The ultimate goal of your curatorial health and safety program is to reduce or eliminate occupational illness and injury.

The servicewide policy outlined in Director's Order (DO) #50B, Occupational Safety and Health, outlines a framework for establishing and implementing a Risk Management process that provides for the safety and health of NPS employees and the public. The Reference Manual 50B, Occupational Safety and Health Program, provides more detailed guidance on specific implementation requirements and strategies for the Risk Management Program in the NPS.

Also familiarize yourself with 29 CFR 1910, Occupational Safety and Health Standards for General Industry. You can find the Federal Register on the web at: http://www.access.gpo.gov/su_docs/.

Build your curatorial health and safety program on these guidance documents. Address these goals:

- Recognize and identify the hazards.
- Evaluate the hazards.
- Reduce or eliminate the hazards to the extent possible.

4. *What are the general categories of occupational hazards?*

Learn the four general categories of occupational hazards. All of these categories are present in the museum work place:

- **Chemical Hazards**—including any chemical that can cause a physical or a health hazard. Hazardous chemicals can be in the form of liquids, mists, vapors, dusts, fumes, gases, and solids
- **Physical Hazards**—including radiation, extreme temperature levels, and noise
- **Biological Hazards**—including exposures to bacteria, fungi, viruses, and parasites and allergic reactions to plants, animals, and other substances
- **Ergonomic Hazards**—including problems with the design and selection of a work environment and poor choices in tools and equipment so that excess physical strain and stress occur

Common hazardous materials you should be aware of include: asbestos, biological samples, cellulose nitrate and cellulose acetate, decaying animal matter, disinfectants and other cleaning chemicals, heavy metal-based dyes and paints, laboratory and photographic chemicals, lead-based paints, medications, munitions, oil-filled electrical equipment (such as transformers and large capacitors), pesticides, and some rocks and minerals. The sections in this chapter discuss these materials in more detail.

B. Understanding Health and Safety Issues

1. *What basic occupational health concepts should I understand?*

There are a number of basic concepts you should understand in order to develop a good safety program.

A hazardous substance is any material that can harm the body if it is absorbed in large enough quantities over a period of time. Each hazardous material, or group of materials, has specific toxic effects.

- **Toxicity** is the material's capacity to produce injury to the human body. The higher the toxicity of a substance, the smaller the quantity of this substance needed to cause injury.
- **Chronic health effects** result from a slow accumulation of small amounts of a hazardous substance. The quantities may seem insignificant; however, with daily exposure over a period of years, material can accumulate in the body. Health effects include respiratory problems, cancer, birth defects in offspring, and damage to the heart, liver and kidneys.
- **Acute health effects** result when a worker is accidentally exposed to large quantities of a hazardous substance. A few symptoms are burning eyes, dizziness, and light-headedness.
- **The exposure limit** for a substance is the highest exposure level recommended in a work area when workers are in that area without any special protection. The two most widely used criteria are:
 - **Permissible Exposure Limit (PEL):** The PEL, established by the Occupational Health and Safety Administration (OSHA), is the concentration and time of exposure that cannot be exceeded. This standard is enforceable by federal law. Many substances also have a determined ceiling for concentration and time of exposure.
 - **Threshold Limit Value (TLV):** The TLV is a guideline based on current studies of exposed animals. It is the recommended maximum average concentration of a chemical during a 40-hour week (five 8-hour days). Results of these studies are issued annually by the American Conference of Governmental Industrial Hygienists (ACGIH). It is a recommended level and is not enforceable by law. The TLV is typically more stringent than the PEL.

The NPS uses 50% of the PEL limit as an action level. If the concentration of a contaminant in a workspace is at or above 50% of the PEL, you must take action to monitor the exposure level and reduce the exposure.

2. *How will I know that I am being exposed to hazardous materials?*

Many hazardous materials have good initial warning properties that signal exposure to a potential injury:

- odor
- burning eyes
- skin, nose and throat irritation
- breathing difficulty

However, after a time, olfactory fatigue may set in, and you will no longer be able to smell the contaminant. Other hazardous materials, especially particulates, give little or no warning. These materials can cause harm when they are present in quantities too small to be detected by odor or other unpleasant indications.

You must identify all hazardous materials in the workplace.

Identifying all hazardous materials in the workplace allows you to identify ways to block and limit exposure.

3. *How does the body absorb substances?*

There are three ways your body absorbs substances:

- ***Skin Contact:*** Healthy, undamaged skin often provides an effective barrier against the absorption of many hazardous substances. Some substances, however, will dissolve or destroy the skin's protective layer. Punctures, scrapes, and cuts increase the risk of absorption. Once a substance is absorbed through the skin, it can cause systemic damage. Be aware of any burning, pain, redness, or irritation when using substances.
- ***Inhalation:*** Hazardous substances are very often airborne (for example, dusts, mists, fumes, vapors, gases). When you inhale these materials, they are absorbed into the blood stream and distributed to all parts of your body. Some materials will damage your lungs; others will pass through into your blood stream. Be aware of common warning signs, such as coughing, a burning sensation, heaviness in the chest, and wheezing or breathing difficulty.
- ***Ingestion:*** You may unknowingly absorb small quantities of a toxic substance into your gastrointestinal system from food or drink or from contaminated hands.

4. *How do I evaluate the degree of a health hazard?*

The factors that determine the degree of a health hazard from a given substance are:

- toxicity of a substance
- amount of a substance
- duration (length and frequency) of exposure

- protective measures used (for example, ventilation, respirators, gloves)
- susceptibility (your health condition at the time of exposure)
- environmental conditions at time of exposure (Temperature, airflow, and humidity affect the dispersion of a hazardous substance, its availability for absorption, and the amount and speed of absorption.)

By looking at each of these factors, you can decide how to limit the hazard to yourself and others in the workplace. For example, you may choose to use a less toxic substance. You might limit how long each day you use the substance. You could choose to wear gloves and protect yourself from direct skin exposure. Looking at each of these factors gives you a number of ways to minimize the hazard.

You should also understand the concept of the breathing zone. The breathing zone is the area around your nose and mouth. Many curatorial tasks are done near the breathing zone, including numbering objects, pulling objects from storage shelves, and dusting. When identifying concentrations of airborne contaminants in a workspace, it is important to determine concentrations in the breathing zone, not just in the general airspace.

Because exposure may occur in more than one way (for example, both ingestion and inhalation of a particulate such as arsenic), biological monitoring may be appropriate. Biological monitoring measures individual absorption by all routes of entry and may include testing of:

- exhaled breath
- urine
- blood

Contact your park safety officer to develop a plan for airborne exposure monitoring and/or biological monitoring if you are concerned about your exposures to hazardous materials.

5. *What is the Job Hazard Analysis?*

The Job Hazard Analysis (JHA) is a written document that evaluates hazards in your workspace (office, storage space, work area, laboratory and research spaces). The purpose of the JHA is to prevent or reduce the risk of job-related injuries and fatalities. The JHA is a tool you use to examine and evaluate activities in the curatorial workplace and to decide on corrective actions to take to prevent accidents. A JHA should be completed for all jobs that:

- have an associated history of injury, illness, or death
- require the use of personal protective equipment (PPE)
- involve activities that are clearly dangerous

Obvious hazards in the curatorial workspace include:

- exposure to toxic chemicals, such as pesticides, preservatives, and solvents
- exposure to dangerous microorganisms, such as hantavirus
- exposure to hazardous materials in collections (for example, nitrate film, radioactive specimens)
- falls from ladders or step stools
- injuries from power tools when constructing storage racks
- injuries from lifting and carrying objects

There may be other hazards specific to your park or its collections.

You can obtain more information about the JHA from:

- Department of Interior Manual (DM), Part 485, Chapter 14
- Reference Manual 50B, Occupational Safety and Health Program, Section 13, available on the web at: <http://www.nps.gov/riskmgmt/>
- OSHA 3071, 1998 (Revised), *Job Hazard Analysis*, an informational booklet that provides a generic overview to conducting a JHA (Available through OSHA on the web at: <http://www.osha.gov/>.)
- OSHA *Self Inspection Checklists*, 1997, checklists that use a question and answer format to guide the user in examining conditions and evaluating hazards, including sections on evaluating a safety and health program and using personal protective equipment (Available through OSHA on the web at: <http://www.osha.gov/>.)

Your park or regional safety officer can also provide specific guidance on conducting a JHA.

C. Controlling Exposure to Hazardous Substances

1. *How do I control exposure to hazardous substances in the workplace?*

When evaluating ways to control exposure in the workspace consider:

- limiting the use of hazardous materials
- installing proper ventilation (including fume hoods, when necessary)
- wearing appropriate personal protective equipment
- practicing good housekeeping and personal hygiene

- storing, handling, and labeling hazardous materials appropriately
- disposing of hazardous materials properly

2. *How do I limit the use of hazardous material?*

Where possible, use a less hazardous material, or use a different method. For example, substitute water-based paints and inks for solvent-based paints and ink. Substitute an IPM monitoring program for use of traditional museum pesticides such as paradichlorobenzene or Vapona. Nitrate negatives can be duplicated and copies provided for research use.

Limit the time of exposure to hazardous substances. Break up tasks that require exposure to hazardous substances into short blocks of time over a number of days.

Close all containers of chemicals when they are not in use. For example, keep the top on the lacquer that you use for numbering objects.

Provide waste receptacles with lids for disposal of toxic materials (especially solvents that will evaporate).

3. *What kinds of ventilation systems are available?*

There are two basic types of ventilation systems:

General or dilution ventilation is designed to keep you comfortable by heating, cooling, and controlling the air's moisture content. The HVAC system for your workspace is a general ventilation system. **Don't** rely on general ventilation to control moderate to high toxicity materials, or reduce concentrations from a "spot source" in your breathing zone.

Local exhaust ventilation captures the hazardous substance where it is generated and carries it away from your breathing zone. It is very effective in removing substances of moderate to high toxicity by using a system of fume or exhaust hoods, ducts, air cleaners, and fans. You should have local exhaust ventilation if you regularly work with hazardous materials. This is the preferred method for removal of air contaminants.

If only low concentrations of hazardous materials are used in your workspace, portable ventilators may be a practical solution. Portable fume or air scrubbers draw air through a charcoal absorption filter with a fan. The filtered air is then released back into your workspace. This is a less expensive alternative, but you must change the filter regularly for these ventilators to remain effective.

Ventilation: A Practical Guide by Clark and others (1984) provides detailed guidance on ventilation systems, including the criteria for designing an exhaust hood system. See Figure 11.1 for the advantages and disadvantages of different types of ventilation. Work with your regional risk manager and park safety manager, the regional/SO curator, and the park's maintenance staff to evaluate the need to improve ventilation in the curatorial workspace.

Ventilation is the key engineering control for protecting staff from the effects of hazardous substances. You should make proper ventilation a high priority when evaluating a curatorial workspace.

4. *How do I install proper ventilation?*

You must work with a ventilation engineer to ensure proper ventilation if a fume hood is installed. For proper ventilation:

- Make sure air in the workspace flows **away** from the breathing zone of each worker to a non-occupied area of the building or to the exterior.
- Pull contaminated air out of the workspace with an exhaust fan. If you try to use a fan to blow air out of a workspace, you will only disperse the contaminant within the workspace.
- Locate the ventilation system's exhaust opening close to the source of the contaminant. Move work to the exhaust area.
- Promote maximum effectiveness of the exhaust system by preventing cross-drafts from interrupting the direct outward flow of air.
- Be sure that the air exhausted from the workspace is replaced. This avoids negative pressure that reduces the ability of the exhaust system to remove contaminants. An engineer will know how quickly air is replaced in the space.
- Ensure that exhaust outlets are not near air intake valves that would pull the contaminant back into the workplace. Work with a ventilation engineer to be sure that outlets are placed properly.
- Avoid polluting the surrounding area with the contaminated exhausts. The level of environmental pollution from exhausts depends on the toxicity and concentration of the substance being vented. These levels must be evaluated by a ventilation engineer.
- Consult local or state environmental regulations on what materials can be directly exhausted. Some materials may require scrubbers in filters under Clean Air Act regulations.

5. *When should I wear Personal Protective Equipment (PPE)?*

Use Personal Protective Equipment (PPE) only when other management controls (for example, ventilation, adoption of an alternative procedure or substance, time limitations on exposure) are not possible. ***Never consider PPE as your primary source of protection.***

PPE includes:

- respiratory devices
- eye and face protection devices
- protective clothing

There is no personal protective equipment designed for universal use. The type of PPE you wear depends on the specific hazardous substances you are using. Material Safety Data Sheets (MSDS) (see Section C) provide specific information about appropriate types of PPE to be used with a specific hazardous substance. See OSHA CFR 1910, Section I, for requirements for PPE usage.

6. *What are respiratory protective devices?*

OSHA CFR 1910.134 specifies that you must use respiratory equipment when engineering controls are not feasible (for example, if you must work temporarily in a dusty attic or basement) or in an emergency. There are two types of respirators: supplied-air devices and air-purifying devices.

- Supplied-Air Respirators bring a fresh air supply from a pressurized tank or compressor. These respirators are complex and expensive. You will rarely need this kind of device in your workspace.
- Air-Purifying Respirators purify air drawn through filters or cartridges before you inhale it. This type of respirator may be made out of a variety of materials depending on the application.

Don't use air-purifying respirators as a substitute for proper ventilation.

7. *How do I select a respirator?*

Use the following criteria to select a respirator:

- OSHA requires a thorough medical exam for anyone who must wear a respirator. This physical must verify that the employee's health will not be at risk while breathing through a respirator.
- Work with your safety officer to select the proper respirator. Be sure it has been approved by the National Institute for Occupational Safety and Health (NIOSH).
- You must have a leak-tight seal between the face and respirator face piece. Facial hair that interferes with this seal is prohibited by law. You must be fit-tested and trained on the use and maintenance of your respirators. Consult with your safety officer for fit-test procedures.
- Choose the proper filtration system. Air-purifying respirators use two types of purifying material—a filter or a chemical cartridge. Filters trap dusts and mists. For chemical vapors you must use a cartridge. Choose a cartridge that is designed for the specific substance in your workspace. Consult the applicable MSDS for the specific type of respirator required (see Section C).
- Consider comfort. Respirators can become uncomfortable after a few hours. Some materials may be more irritating to a wearer than the presence of the contaminant.
- Consider cost and maintenance. Some respirators (for example, paper) are disposable. Others are not and require periodic maintenance and cartridge replacement.

Refer to Appendix H for sources of respirators. Good sources of information on respiratory protection can be found in *Conserve O Gram* 2/13, "An Introduction to Respirator Use in Collections Management," and on the OSHA Website at <<http://www.osha-slc.gov/SLTC/respiratoryprotection/index.html>>.

8. *How do I know which gloves to wear?* There are many types of gloves manufactured to protect against different types of materials. Consider the chemicals you are handling and the permeability rate. For example, gloves made from butyl give the best protection from acetone. You may use properly maintained butyl gloves for over 17 hours before replacing them. In contrast, neoprene gloves provide only 10 minutes of protection from acetone before it penetrates to your skin. Refer to the MSDS or check with manufacturers for each chemical that you are using to identify recommended types of gloves.

Refer to Appendix H for sources of gloves.

9. *What good housekeeping and personal hygiene habits do I need to develop?* Good housekeeping and personal hygiene can go far in protecting you and others from contact with hazardous substances. Follow these rules:

- Establish a routine program for cleaning floors and work surfaces.
- Change filters in ventilation systems regularly.
- Clean up any spills immediately.
- Don't allow smoking in workspaces.
- Don't allow eating or drinking in workspaces.
- After working with objects, wash your hands before eating, applying makeup, brushing your hair or leaving work.
- Take special note of personal habits and refrain from biting your nails or chewing on pencils.

10. *How do I store, handle, and label hazardous material?* Follow these rules:

- Store all chemicals in an approved dedicated space and only with compatible materials. Never store these materials in the same space with a museum collection.
- Store large quantities of flammable and combustible materials in special cabinets that meet OSHA and NFPA specifications. Refer to Appendix H for sources of these cabinets.
- Label all containers. Post appropriate warning signs in the storage area. Refer to Section C for information on labeling.
- Close all chemical containers when they are not being used.
- Wear appropriate personal protective equipment when using chemicals.

11. *How do I dispose of hazardous waste?* **Hazardous waste** is any hazardous solid, liquid, or contained gaseous material that you no longer use. You must recycle, discard, or store hazardous waste. Common materials that you use in museum tasks may become hazardous waste, such as alcohol and formaldehyde, pesticides, and other solvents.

Under the Federal Hazardous Waste Management Program, you will have to follow different rules depending on the amount of hazardous waste you generate in a given month. Work with your safety officer and the Regional Hazardous Waste Coordinator on proper disposal methods for all hazardous materials, including empty hazardous materials containers.

You must dispose of all hazardous waste in accordance with the Resource Conservation and Recovery Act (RCRA) of 1976. All cataloged museum objects that are disposed of because of hazards must first be evaluated and deaccessioned.

For a detailed explanation of the regulations, obtain a copy of the Environmental Protection Agency (EPA) publication, *Understanding the Hazardous Waste Rules: A Handbook for Small Businesses—1996 Update*. See *MH-II*, Chapter 6: Deaccessioning, Sections B.5 and H.

D. Hazardous Chemicals and Materials Used in Collections Care

Collections care requires the use of numerous hazardous chemicals. The following information gives you basic information about commonly used materials; however, you should evaluate your own workspace and identify all hazardous substances.

1. *What solvents are used regularly?*

You may find numerous hazardous substances in the curatorial workspace. These can include:

- paints
- varnishes
- waxes
- cleaning materials
- preservatives and consolidants
- adhesives

Some of the common hazardous solvents are: acetone, ethanol, kerosene, methanol, mineral spirits, toluene, turpentine, and xylene. Mineral spirits, V.M.&P® Naphtha, and Stoddard Solvent are used in cleaning wooden furniture. The clear and white lacquers recommended by the Supply and Equipment Program for numbering objects contain acetone. In natural history collections, formaldehyde, ethanol, and methanol are used to preserve wet specimens.

Rapid Guide to Hazardous Chemicals in the Workplace by Richard Lewis (2000) is an easy-to-use reference. It deals with the properties and harmful health effects of 700 common substances.

2. *What fumigants and other pesticides do museums use?*

Museums have traditionally used chemicals to control biological infestations, including fumigation and topical application of pesticides. In more recent years, Integrated Pest Management (IPM) has become the standard for protecting collections (see Chapter 5: Biological Infestations). However, many collections are still contaminated with residues from these past treatments.

Fumigation introduces a toxic gas into a fixed space that contains the objects. Fumigants that have been used on museum collections include:

- dichlorvos (DDVP, Vapona)
- ethylene oxide
- methyl bromide
- paradichlorobenzene
- naphthalene (moth balls)
- sulfuryl fluoride (Vikane®)
- thymol

Materials that have been applied through topical application include:

- arsenic
- DDT
- mercuric chloride

3. *What should I know about pesticide use?*

Pesticide residues are a serious problem in museum collections and the full extent of the problem is just becoming known. In many cases there is little documentation on past pesticide usage. Repatriated objects are of particular concern because they are returning to communities that may have little or no knowledge of the hazards of pesticide contamination.

Information in Chapter 5: Biological Infestations will help you to identify problems in your collections and show you how to limit or halt the future use of pesticides by using IPM techniques. Refer to Appendix H: Section E, for a list of fumigants that were traditionally used in museums and for health and reactivity information. The *Conserve O Gram* series has additional health and safety information about these materials. Review these publications to acquaint yourself with the dangers of pesticide use and how to manage contaminated collections.

Vikane (sulfuryl fluoride) is now the only fumigant that is legally available to use on collections. All others have been banned. It is a restricted use pesticide that requires park and regional IPM approval before application. See Chapter 5: Biological Infestations and the *Conserve O Gram* series for information on alternative non-toxic treatment strategies if you find an infestation in your collections. Work with your regional/SO curator and park IPM coordinator to develop alternative strategies to pesticide use.

Use of any pesticide must follow policy in NPS-77: Natural Resources Management Guideline, Integrated Pest Management (Chapter 2, p. 217-266).

You must obtain approval for using a pesticide through the Pesticide Use Proposal System (PUPS) or by telephone, as described in NPS-77. A regional/SO or WASO IPM specialist must review and approve all pesticides prior to use.

The regional/SO IPM specialist:

- consults with the regional curator to evaluate the need for pesticide use and to ensure that any approved use is an integral part of the integrated pest management process
- consults with WASO IPM specialist for concurrence if the pesticide is a restricted use product, will be used on or near an aquatic system, may affect threatened or endangered species, or is to be applied over 400 contiguous acres
- responds to park IPM coordinator within five working days with either approval or denial with suggested alternative management strategies

The park IPM coordinator:

- works with curatorial staff to ensure that pest management activities, including use of pesticides, are directed by technical experts and follow pesticide label instructions
- submits PUPS use to regional/SO IPM coordinator at end of each calendar year as directed in NPS-77

There may be times when it is appropriate to use a fumigant on museum objects. It may also be appropriate to use pest deterrent chemicals, such as crack and crevice solutions, in the museum space around collections. However, be sure you make the decision to use pesticides with the approval and advice of experienced and trained NPS staff.

4. *Are there special precautions for using silica gel in exhibition and storage cases?*

Yes. Silica gel may cause irritation to skin, eyes, and the respiratory tract. Goggles, a lab coat, vent hood (or appropriate respirator), and proper gloves should be used when working with bulk silica gel. Obtain a Material Safety Data Sheet (MSDS) from the silica gel manufacturer for further information. (Also see Sections D.5 and D.6 below.)

Cobalt impregnated silica gel should be phased out of use and replaced by Sorbead Orange, Silica Gel Yellow, or other biodegradable indicating gels. Cobalt is a skin and respiratory system sensitizer. Contact your park or regional HAZMAT coordinator to obtain information on appropriate disposal of cobalt impregnated silica gel. (See *COG 2/15*, Cobalt Indicating Silica Gel Health and Safety Update.)

5. *What is the Hazard Communication Standard?*

Your park must implement a program to communicate essential information on hazardous chemicals. This is required by OSHA's 29 CFR 1910.1200 (the Hazard Communication Standard) and NPS policy. This means you must:

- inventory all hazardous substances
- obtain and maintain a Material Safety Data Sheet (MSDS) for all hazardous chemicals
- label all hazardous substances
- receive training in the Hazard Communication Standard

6. *What is a Material Safety Data Sheet (MSDS)?*

A MSDS is a concisely written information sheet that explains the hazards of substances and how you are required to handle and use them. The OSHA standard does not require that MSDS be uniform in format; however, each sheet must contain the following information:

- product name and identification of chemicals including:
 - identification of the substance
 - manufacturer's name
 - both chemical and trade names and any synonyms
 - chemical family and chemical formula
 - name and address of the manufacturer with emergency telephone number
 - hazardous ingredients
 - percentage of each ingredient
 - recommended exposure limits for these ingredients
- physical and chemical characteristics of each hazardous chemical including:
 - physical properties (boiling point, melting point, appearance and odor threshold, solubility in water, evaporation point)
 - fire or explosion hazards (flash point, flammable limits, fire extinguishing equipment needed)
 - list of substances that cause it to burn, explode, or release toxic gases (for example, water or other chemicals)
 - list of environmental conditions that cause a dangerous reaction (for example, heat or direct sunlight)

- health hazards including:
 - known acute and chronic effects
 - exposure limits (PEL and TLV)
 - known or suspected carcinogenic effects
 - emergency and first aid procedures
 - primary route of exposure (for example, skin, nose and mouth)
- special protective information including:
 - special control measures, such as ventilation requirements
 - appropriate personal protective equipment (for example, respirators, gloves, goggles, or clothing)
- spill or leak procedures, handling and storage information:
 - special handling and storage precautions
 - procedures for cleaning up spills and leaks and disposing of resulting waste

This last information is often regulated by the U.S. Department of Transportation and by statutes and laws like the Toxic Substances Control Act and the Resource Conservation and Recovery Act. This information is especially important when you prepare your emergency operations plan (EOP).

7. *How do I get and maintain a MSDS?*

You should be able to obtain a MSDS when you purchase a hazardous chemical or a product that contains a hazardous material. If you currently have hazardous materials in your workspace and do not have a MSDS for them, you can get it by contacting the manufacturer. Always ask the manufacturer first. The manufacturer is obliged by law to provide a MSDS. There are also several institutions that maintain collections of material safety data sheets on the Web; however, they may not be the specific formulation you are using. You can search for these at <http://palimpsest.stanford.edu/bytopic/health/#msds>.

Request the MSDS whenever you make a purchase from the Government Services Administration (GSA) and other vendors. Keep the MSDS in an easily accessible file that is available to everyone in the curatorial workspace.

See Figure 11.2, Sample Material Safety Data Sheet and Figure 11.3, MSDS for Formaldehyde.

8. *How should I label hazardous substances?*

OSHA's Hazard Communication Standard requires that all chemical labels include a hazard warning. Prepare labels for chemicals you use in your daily work, such as the lacquer you use for numbering objects. Refer to Appendix H for sources of vendors who provide a variety of label materials.

Include the following information (recommended by the American National Standards Institute) on all labels:

- chemical name and any synonym
- signal word to indicate the degree of severity of a hazard (in increasing order):
 - CAUTION!
 - WARNING!
 - DANGER!
 - POISON! (used only for highly toxic chemicals)
- statement of hazard
- precautionary statement
- effects of over exposure
- first aid procedures
- chemical abstract service number

9. *What is the NFPA Hazard Symbol?*

The National Fire Protection Association (NFPA) Hazard Symbol is an effective labeling system that you should consider using. This system uses a diamond-shaped symbol to rate the health, fire, and reactivity hazard of a substance to warn personnel if there is a fire. See Figure 11.4. The hazard warning system uses a 0 to 4 rating with 0 being the least hazardous and 4 the most hazardous. You can use this label on any size container. You can also post the label on access doors to storage rooms or cabinets containing hazardous materials (for example, cellulose nitrate film). It is a warning to all employees and to firefighters. Refer to Figure 11.4 for an explanation of the NFPA warning rating system.

10. *How can I get occupational safety and health training?*

Your employer must provide you with appropriate occupational safety and health training to equip you with the knowledge and skills to safely perform your job and to respond to potential emergencies.

Contact your Regional Training Coordinator, or your Regional Safety Manager for Safety and Health for available training.

E. Hazardous Objects in Collections

1. *What type of hazardous objects are in collections?*

This section describes what to do with the most common hazards in collections including:

- pesticide residues
- hazardous geological specimens (radioactive minerals, asbestos, toxic minerals)
- cellulose nitrate and cellulose acetate film and negatives
- firearms, edged weapons, ammunition, and unexploded munitions
- medical objects and drugs/chemicals
- objects containing asbestos

You should familiarize yourself with the types of hazardous objects that are typically found in collections. Be aware of the health and safety risks. Review *Conserve O Gram* 2/10, Hazardous Materials in Your Collections, as well as references listed in Section H, to get additional information about hazardous collections and how to protect yourself.

2. *Why should I be concerned about pesticide residues in biological specimens and organic ethnographic and historic objects?*

Many historical biological specimens (birds, mammals, and plants) and ethnographic and historic organic materials were treated with pesticides. These pesticides can leave residues. See the article "Masked Hazard" listed in the references for a discussion of the problems that pesticide residues can cause.

At this time, arsenic is a residue that you can identify with a simple test. See Section E.4 below. The mercuric chloride spot tests that are currently available do not work consistently. Other pesticide residues that may be present don't have simple identification tests. A number of researchers are working in this area, and new information will be published in the *Conserve O Gram* series as it becomes available. The following *Conserve O Gram* leaflets have health and safety information on commonly used pesticides:

- 2/2, Ethylene Oxide Health and Safety Update
- 2/3, Arsenic Health and Safety Update
- 2/4, Dichlorvos (Vapona) Update
- 2/10, Hazardous Materials in Your Collection

Under no circumstances should any taxidermy mount be used for "hands-on" demonstrations for children or adults before it has been tested for the presence of arsenic.

Collect and document information on pesticide use in your collection. Talk to individuals who worked in the park in the past. Search documents such as:

- accession and catalog records
- annual reports
- maintenance records
- purchasing records
- diaries or other informal records from previous curators
- conservation records

3. *What do I do if I have specimens contaminated with arsenic?*

Arsenic can be readily absorbed through the skin, inhaled, and ingested. Arsenic can cause acute symptoms or may lead to chronic disorders. It is a known human carcinogen. In working with contaminated ethnographic and biological collections (especially bird and mammal specimens) use the following handling precautions:

- Do not touch specimens with bare skin. Wear plastic gloves and a protective smock or lab coat. Wear a dust mask rated for toxic dust. If possible, handle an object or specimen by a container or a mount.
- Always wash hands after working with specimens. Discard gloves. Keep the protective smock or lab coat clean. Do not take protective clothing home to wash—especially if you live with small children or elderly people.
- Obtain a Material Safety Data Sheet (MSDS) on arsenic and keep in the park's curatorial workspace/office. Consult the MSDS for specific information on arsenic.
- Label museum cabinets or storage spaces that house specimens contaminated with arsenic with the warning sign "ARSENIC." Also label individual specimens that have been tested. Prepare and post a written set of instructions for handling specimens contaminated with arsenic.

4. *How do I identify specimens that are contaminated with arsenic?*

You should inspect all biological collections (birds, mammals) and ethnographic objects made from organic materials (leather, basketry, textiles). These collections were typically treated with arsenic.

Test all bird and mammal specimens collected and prepared prior to the mid-1970s.

Follow these procedures to identify arsenic:

- Wear plastic gloves and a lab coat or smock while you inspect each specimen or object. Look for powdery or crystalline deposits. On bird and mammal specimens, look on the tips of feathers and hair, along

eyes, in or at the base of ears, around mouth or bill, along ventral incision, at the base of tail, and on foot pads. On ethnographic objects, look along seams, at the base and tips of feathers or hair, in areas of stitching, in folds and on the shelving beneath an object. Some application techniques, however, dispersed the arsenic as such fine powder that you may not be able to see it.

- Study each specimen and object's history. Try to determine who collected and prepared the specimen, when it was collected, and where it was collected.
- Follow the instructions for identifying arsenic residues provided in *Conserve O Gram 2/6*, Arsenic Health and Safety Update. Refer to *NPS Tools of the Trade* for sources of the EM Science arsenic test kit. Document each test with a written report and keep the reports in the museum records accession or catalog folder.
- Tag specimens and objects testing positive for arsenic with an "ARSENIC" warning sign.
- Inform the park safety office about the project and the results.
- Disclose any test results or information on suspected pesticide contamination to researchers or visitors who may touch objects and also to recipients when repatriating objects.
- Develop an emergency response plan to deal with the rescue of contaminated objects after a flood or fire. These objects are a severe health risk when wet.

5. *What hazards will I find in geological collections?*

A few types of geological specimens are hazardous. See *Conserve O Gram 11/2*, Storage Concerns for Geological Collections, for a basic discussion of health hazards. The main hazards are:

- radiation from radioactive specimens (for example, pitchblende [uraninite] is strongly radioactive)
- radon from fossils
- toxic minerals (for example, antimony, arsenic, barium, boron, copper, fluorine, lead, uranium, zinc)
- asbestos (a carcinogen)
- clay and quartz dust
- off-gassing from mercury compounds

Certain individuals may also have allergic responses, such as dermatitis, from particular minerals.

Label all known hazardous materials.

6. *Why are cellulose nitrate and diacetate negatives hazardous?*

Both aging cellulose nitrate and acetate film off-gas chemicals that can be irritants and toxic hazards. Cellulose nitrate emits nitrogen oxide gas, which has a sweet odor; cellulose acetate emits acetic acid, which has a sharp vinegar odor.

Cellulose nitrate is also volatile and flammable. Motion picture film is especially dangerous and in extreme cases has been known to self-ignite when stored improperly. The by-products can also cause deterioration of other materials stored in the same space.

Acute symptoms include:

- eye irritation
- rashes and sores on the face and skin
- vertigo
- nausea
- headaches
- swollen glands
- respiratory irritation and difficulty breathing

Repeated exposure by inhalation to the emissions of these deteriorating films may result in chronic symptoms, such as bronchia irritation or development of an emphysema-like condition. See Appendix M: Management of Cellulose Nitrate and Ester Film, for more information on the hazards of cellulose nitrate and acetate film.

In addition, the silver salts present in negative emulsions may irritate the skin.

7. *How can I protect myself when working with cellulose nitrate and acetate film?*

To protect yourself when working with nitrate and acetate film follow these steps:

- Plan for your project. Make sure you have the required work-space, equipment, and time. Identify any special protective equipment you will need.
- Ensure that the workspace has proper ventilation to remove emitted gases from your breathing zone. See Section C for a discussion of ventilation and respirators.
- Wear goggles unless proper ventilation is established. Do not wear contact lenses. Gases can concentrate under contact lenses causing eye injury and damage to the contact lens.
- Wear plastic gloves (vinyl, latex, nitrile) to minimize the risk of skin irritation. You can wear cotton gloves over the plastic gloves.
- Don't work with nitrate and acetate negatives more than two or three hours a day.

- After each work session, clean the work surface with a solution of baking soda and water. Mix one teaspoon baking soda with one pint of water. This solution neutralizes any acid that the negatives deposit.
- Keep a log in the work area. Note any odors you detect, the time spent each day on the project, and physical discomfort you have during or after work. If you experience any ill effects, notify your supervisor and the park safety officer.

8. *What particular concerns should I have with archival records?*

Other major archival health and safety issues are:

- asbestos that has contaminated records (See *Conserve O Gram* 2/11, Health and Safety Risks of Asbestos.)
- broken glass plate negatives and transparencies, which can be difficult to handle without cutting yourself
- bird, bat, insect, and rodent contaminated materials or flooded materials that may have viral or bacterial contamination, including hantavirus (See *Conserve O Gram* 2/8, Hantavirus Disease Health and Safety Update.)
- chemically or radiologically contaminated records
- mold, fungi, and yeasts, which can cause allergies, asthma, histoplasmosis, and ringworm (See *Conserve O Gram* 3/4, Mold and Mildew: Prevention of Microorganism Growth on Museum Collections.)

9. *What do I need to know about firearms and live ammunition?*

You must inspect all firearms when you acquire them to make sure they are not loaded. Until a historic firearm is examined, treat it as if it were loaded. Inspect all breach loading firearms and pistols for cartridges. Remove any cartridges that you find.

Follow these steps to check a muzzleloader for live ammunition. You will need a wooden dowel smaller in diameter than the firearm's caliber and longer than its barrel.

- Select a safe, dedicated work area. Place the firearm on a padded table. Point the muzzle so nothing will be harmed if it accidentally fires. ***Never stand in front of a firearm's muzzle.***
- Wear leather gloves and safety goggles.
- Be sure the firearm is not cocked.
- Standing to the side of the firearm, gently push the dowel into the muzzle until it stops. Hold the dowel between the thumb and forefinger so that the dowel will be propelled ***between*** the fingers should the firearm discharge. ***Do not hold the dowel in such a way that it can be propelled into your hand.***
- Place a pencil mark on the dowel where it just clears the muzzle of the barrel.

- Gently withdraw the dowel from the barrel.
- Place the dowel on top of the barrel with the pencil mark aligned with the muzzle. If the other end of the dowel extends the full length of the barrel, the weapon is not loaded. However, if the measurement indicates that the dowel stopped forward of the touch-hole, consider the firearm to be loaded with a live round.
- Inform the Park Safety Officer of the potential problem. Label the firearm as unsafe and arrange to store it in a secure space.
- Contact the regional/SO curator for instructions on disarming the weapon.

See *Conserve O Gram* 10/1, Caring for Historic Longarms: Storage and Handling Requirements, for more information on safely disarming weapons.

10. *What do I need to know about small arms ammunition?*

Small arms ammunition includes Revolutionary and Civil War paper musket cartridges; metallic cartridges used in the American West; and contemporary pistol, rifle, and machine gun ammunition from World Wars I and II. These small arms cartridges do not pose a serious risk unless they are damaged. Tests conducted by the U.S. Army, the National Rifle Association, the arms industry, and several fire and insurance companies have repeatedly demonstrated that such ammunition will not detonate by itself. This kind of ammunition requires a direct blow to its primer or a direct spark or flame to detonate the powder. If this ammunition is accidentally detonated when it's not confined within the barrel of a firearm, the pressure drops rapidly. The bullet will fly out of the cartridge with about the same velocity as a cork from a champagne bottle.

Follow these general rules for safely handling small arms ammunition:

- Never attempt to deactivate small arms ammunition. Procedures such as drilling holes in a cartridge case or pulling a bullet to remove the powder and charge can be extremely dangerous. If you must deactivate the ammunition, contact a specialist.
- As with all museum collections, prohibit smoking.
- In parks with large collections, store live cartridges in a separate museum specimen cabinet. Clearly label the cabinet with a warning sign to notify fire-fighting personnel.
- If you want to put fixed ammunition on exhibit, it must be rendered inert. Contact the regional/SO curator for guidance in rendering ammunition inert.

11. *What do I need to know about unexploded munitions?*

Unexploded munitions (e.g., cannon balls, Borman fuses, grenades, artillery projectiles) constitute a major health and safety risk.

Treat any unexploded ordnance discovered in a collection with extreme caution. Considerations for the safety of staff, visitors, and resources take precedence over the preservation of even rare ordnance.

Don't handle this material unless you have received specific training and authorization in writing by the superintendent. If you discover ordnance that you suspect is unexploded, immediately take the following steps:

- Do not move or disturb the object.
- Keep all other persons away from the object. Secure the storage space.
- Notify the Chief Park Ranger or other designated protection officer and the Park Safety Officer. Contact the regional/SO curator.
- Work with the Chief Park Ranger and the regional/SO curator to have the object(s) examined and evaluated by an appropriate authority to identify the type of ordnance, manufacturer, historic period, and significance.

If the object is rare, novel, or limited in production (for example, Whitworth projectile, Armstrong projectile, Confederate Mullane projectile) or is identified in the park's approved Scope of Collection Statement, make every attempt to defuse it and preserve the inert object in the collection.

12. *What types of hazardous medical objects and drugs/chemicals are in collections?*

Museum collections can contain a variety of hazardous medical objects and drugs/chemicals.

Handle old medical equipment and medicine or chemical bottles with extreme caution.

Knives, saws, scissors, and other objects from military and civilian medical kits may still carry viable germs and may contain active toxic substances (for example, strychnine, opium, and morphine). The active ingredients of drugs or chemicals, originally very potent, may have become even more potent over time. Drugs, medicinals, and other preparations in pharmaceutical collections may contain toxic materials and/or controlled substances (for example, narcotics). The Controlled Substances Act of 1970 regulates these types of substances. Watch for bottles containing:

- acids and other corrosive liquids (for example, nitric acid)
- fuels (for example, kerosene, naptha®)
- solvents (for example, paint thinners, turpentine)

These chemicals are hazardous and pose the threat of fire. Very often old chemicals contain such labels as "Oil of Vitriol" (sulfuric acid) and "Aqua Fortis" (nitric acid).

13. *What should I do with medical objects and drugs/chemicals?*

Survey the park's collections to determine if they contain any drugs, medicinals, or other preparations that pose potential health or safety hazards. Report findings to the park Safety Officer. If the survey identifies that such materials are in the collection, notify the regional/SO curator and regional Risk Manager and proceed with the following steps:

- Prepare an inventory of the drugs and medicinal chemicals. Start with the containers that have labels. Include the following information in the inventory:
 - name of the substance
 - all information on the label
 - type of container (for example, glass bottle, metal canister, cardboard box) and its lid or stopper
 - condition of container (for example, condition of seal; cracked, chipped bottle; rusty metal; punctured box)
 - other (for example, strong odor being emitted from container)
- List material that cannot be identified and isolate it on a separate shelf for a more detailed examination. Agents of the U.S. Department of Justice, state agencies (such as state crime labs), local pharmacists, and local pharmaceutical manufacturers can provide assistance with identifying this material.
- Conduct a detailed examination. Based on the inventory list or an examination by appropriate specialists, divide the substances into the following groups:
 - "over-the-counter" preparations that are considered non-toxic if precautions are followed and that are not controlled substances
 - non-controlled drugs or preparations that may be toxic or potentially hazardous in some applications or that would require a physician's prescription to get today
 - controlled substances (such as narcotics and dangerous drugs) as defined by the Controlled Substances Act of 1970
 - drugs that may pose a health/safety hazard because of their age or level of deterioration
- Implement an action plan. Based on your inventory and on the detailed examination, pursue the following actions:

<i>If</i> drugs, medicinals, and preparations...	Then you should...
are not controlled, are non-toxic (with usual precautions), and pose no other hazards to the rest of the collection or to the staff,	retain them.
are not controlled but may be toxic or require a prescription to obtain,	retain them only if they are stable and pose no health- hazards to the staff or risk to the rest of the collection. House this material in a locked utility cabinet.

If these materials will become a hazard in the future, consider depositing a sample with the Division of Medical Sciences at the Smithsonian Institution, National Museum of American History (NMAH) and destroying the remainder. This ensures that future staff will not be exposed to hazards from these substances. Check with the division in advance to determine what size sample to save.

- Destroy drugs and medical chemicals that are:
 - controlled substances as defined by the Controlled Substances Act of 1970
 - so toxic that their continued presence in the collection poses an unacceptable risk
 - an immediate hazard to the rest of the collection or the staff because they are dangerously unstable, corrosive, or explosive

If you must destroy material, for whatever reason, retain a small sample for research and reference purposes, and deposit it with the Division of Medical Sciences at the NMAH. Take, account for, and transmit samples of controlled substances in accordance with Drug Enforcement Administration (DEA) procedures. Contact the DEA for assistance. If the specimen to be destroyed is not a controlled substance, contact the Regional Hazardous Waste Coordinator for instruction on proper disposal of the material.

14. *What should I do with original containers?*

Take into account preservation of the original containers when saving or destroying drugs and medical chemicals in the collection. You can open an original, unopened container for the purpose of removing its contents only when:

- the act of opening will not permanently damage the container or diminish its value
- there are urgent and compelling health and safety reasons for opening the container
- the contents are endangering the container (for example, by corrosion) and removal of the contents is the only way to stop the problem

- the act of opening the container poses no safety problem (for example, container exploding or releasing toxic material)

If you are keeping substances in the collection, you may want to transfer them to modern containers. Do this if the original containers can no longer hold them safely. Preserving the original containers is a high priority.

If your collections include original, unopened containers of substances that must be destroyed to comply with the law, the containers are in good condition and thus would not have to be opened otherwise, but can't be opened without causing unacceptable permanent damage, then the containers and their contents shall be deaccessioned (out of scope) and transferred to the Division of Medical Sciences at the Smithsonian Institution.

Keep full descriptive information about the transferred objects, including one or more photographs, with the park's catalog records. Refer to *MH-II*, Chapter 6: Deaccessioning, for information on deaccessioning hazardous material.

When substances in the collection are to be destroyed, save the original containers. Previously opened containers may be emptied as necessary with routine precautions taken for their preservation. Clean emptied containers thoroughly before returning them to storage or exhibit.

If the container held a controlled substance, NO residue may remain in the container according to DEA regulations.

F. Safety Rules for Lifting and Carrying

Chapter 6 in this handbook discusses the importance of using proper techniques when lifting and carrying museum objects. Improper handling techniques may lead to accidental damage to the object. You may injure yourself by improperly lifting and carrying boxes of objects, furniture, and other large and heavy objects. Safely lifting and carrying museum objects requires planning.

1. *How should I plan for lifting and moving objects?*

Careful planning before lifting and moving objects can minimize the chance of injury. Follow these guidelines:

- Consider the size and weight of the load and ask for help if the object is too heavy or bulky to lift and carry safely by yourself.
- Examine the objects for hazards: sharp or broken edges, or contamination, such as mold, or asbestos.
- Have mechanical help at hand. Use a push cart or handtruck to move heavy or bulky objects.

2. *How do I lift and carry an object safely?*

Follow these rules:

- Get close to the object.
- Keep your back **straight** (not arched) when lifting.
- Keep head high and chin tucked.
- Keep feet apart, one foot ahead and one foot behind, to maintain a wide base of support.
- Use legs to help with the lift.
- Push or pull large, heavy objects on a cart, when possible, rather than carry them.
- Use teamwork and good communication when two or more are helping with a load.
- Pivot your feet rather than twisting them when turning with a load.

3. *How do I reach for an object safely?*

Follow these rules to avoid injury when reaching for museum objects.

- Use a step stool for objects slightly out of reach.
- Use an appropriate and sturdy ladder to reach objects on high shelves.
- Maintain proper posture when reaching overhead.
- Store heaviest objects between knee and chest height.

G. Workspace Conditions

1. *What makes a safe and healthy curatorial workspace?*

A safe and healthy curatorial work environment includes good lighting, ventilation, good housekeeping, appropriate type and number of fire extinguishers, and a comfortable chair. Consult with your safety officer on steps that you can take to improve your workspace. You can find information about creating or improving your workspace by referring to sources in Section I, Web Resources, and Section J, References.

2. *When should I worry about radon?*

Radon may be a concern in some curatorial workspaces, especially in basements or certain well-sealed spaces. The natural disintegration of uranium generates radon gas. Radon is prevalent in areas where soils and rocks naturally contain uranium, phosphates, and pitchblende. It may also be a problem where the soil is contaminated with the by-products from uranium or phosphate mining. This colorless, odorless gas seeps into structures through dirt floors, cracks in concrete floors and walls, floor drains, sumps, slab joints, and cracks and pores in concrete block walls. Radon tends to accumulate in enclosed spaces. Levels of radon depend on the structure's construction and on the concentration of radon in the soil.

Radon in the short-lived gaseous state is not harmful. However, the gas breaks down into radioactive particulates (for example, heavy metals) called "radon daughters." These radioactive decay products attach themselves to dust or exist as free ions. If you inhale these particles, they can become trapped in the lung tissues and eventually cause lung cancer. Curatorial staff should determine if there is a potential radon problem in museum collection spaces, especially in work and storage areas (for example, basements or well-sealed spaces).

3. *How do I know if there is radon in my workspace?*

Discuss a radon monitoring program with the park Safety Officer or the Regional Risk Manager. Radon may already have been identified in park structures.

If radon levels have not been determined, request a short-term screening measurement. There are numerous types of monitoring equipment. Work with an individual who has experience and training in monitoring. For assistance in finding individuals experienced in testing for radon you can contact your state radon office. Contacts are listed on the EPA website at <<http://www.epa.gov/iaq/contacts.html>>. You can also contact the EPA at: U.S. Environmental Protection Agency, Office of Radiation and Indoor Air, Indoor Environments Division (6609J), 401 M Street SW, Washington, DC 20460; (202) 564-9370; fax: (202) 565-2038.

The amount of radon in the air is measured in "picocuries of radon per liter of air," or "pCi/L." Sometimes test results are expressed in Working Levels (WL). A level of 0.02 WL is equal to about 4 pCi/L.

Practical remediation methods typically can reduce the indoor radon concentrations to well below 4 pCi/L, the current EPA action level for all occupied buildings. EPA indicates that most structures can be reduced readily to below 2 pCi/L.

4. *What do I do if there is a radon problem in the workspace?*

Work with other park staff to reduce the flow of radon into the space. The methods for reducing radon flow include covering exposed earth and sealing cracks and openings (for example, pores in concrete blocks, openings around utility pipes, joints between basement floors and walls, floor drains). This method can achieve the desired reduction in radon levels at small cost. You must implement this method before using other methods. If the radon remains at an unacceptable level, try one or both of the following methods:

- Ventilate the space with natural, forced, or heat recovery systems. Ventilation reduces radon levels by replacing radon-laden indoor air with outdoor air. Change in ventilation, however, may cause problems maintaining the appropriate environment for museum objects.
- Install a system to keep radon from entering space. These more expensive methods include drain-tile suction, sub-slab suction, and block-wall ventilation prevention of space depressurization, and space pressurization.

For a detailed discussion on radon reduction methods, get a copy of the EPA publication *Consumer's Guide to Radon Reduction: How to Reduce Radon Levels in Your Home* (1992) from the nearest EPA Regional Office, or download it from the EPA Website at <<http://www.epa.gov/iedweb00/radon/pubs/consguid.html>>.

H. Glossary*

Acute conditions: severe, often dangerous conditions in which relatively rapid changes occur

Acute exposure: intense exposure to a hazardous substance over a relatively short period of time

Boiling point: temperature at which the vapor pressure of a liquid equals atmospheric pressure or at which the liquid changes to a vapor. The boiling point is usually expressed in degrees Fahrenheit. *If a flammable material has a low boiling point, it indicates a special fire hazard.*

Breathing Zone: ambient environment in which a person performs normal respiration (around nose and mouth)

Ceiling ("C"): concentration of a substance that should not be exceeded, even for an instant. It may be written as Threshold Limit Value-Ceiling or TLV-C.

Carcinogen: substance or physical agent that may cause cancer in animals or humans

Chronic conditions: persistent, prolonged, or repeated conditions

Chronic exposure: exposure occurring over a period of days, weeks, or years

Combustible liquids: liquids with flash points at or above 100°F (37.8°C) or those that will burn. They do not ignite as easily as flammable liquids. However, combustible liquids can be ignited under certain circumstances, and must be handled with caution. (Substances, such as wood and paper are termed "ordinary combustibles.")

Flammable liquids: liquids with flash points below 100°F

Flash Point: lowest temperature at which a liquid gives off enough vapor to form an ignitable mixture and burn when a source of ignition (e.g., sparks, open flames, cigarettes) is present. Two tests are used to determine the flash point: open cup and closed cup. The test method is indicated on the MSDS after the flash point.

Hazardous material: chemical or mixture of chemicals that is toxic, highly toxic, an irritant, a corrosive, a strong oxidizer, a strong sensitizer, combustible, flammable, extremely flammable, dangerously reactive, pressure-generating, or otherwise may cause substantial personal injury or substantial illness during or as a direct result of any customary or reasonable foreseeable handling or use

Lower Explosive Limit (LEL): lowest concentration of a substance that will produce a fire or flash when an ignition source (for example, flame, spark) is present. It is expressed in percent of vapor or gas in the air by volume. Below the LEL the air/contaminant mixture is theoretically too "lean" to burn.

Mutagen: anything that can cause a change (or mutation) in the genetic material of a living cell

Narcosis: stupor or unconsciousness caused by exposure to a chemical substance

Odor threshold: minimum concentration of a substance at which a majority of test subjects can detect and identify the substance's characteristic odor

Permissible Exposure Limit (PEL): exposure limit that is published and enforced by OSHA as a legal standard. PEL may be a time-weighted-average (TWA) exposure limit (8 hour), a 15-minute short-term exposure limit (STEL), or a ceiling (C). The PELs are found in Tables Z-1, Z-2, or Z-3 of OSHA regulations 1910.1000.

Reactivity: substance's susceptibility to undergoing a chemical reaction or change that may result in dangerous side effects, such as explosion, burning, and corrosive or toxic emissions. The conditions that cause the reaction, such as heat, other chemicals, or mixing with water and dropping, will usually be specified as "Conditions to Avoid" when a chemical's reactivity is discussed on a MSDS.

Short Term Exposure Limit (STEL): maximum concentration to which workers can be exposed for a short period of time (15 minutes) for only four times throughout the day with at least one hour between exposures

Threshold Limit Value (TLV): airborne concentrations of substances established by the ACGIH that represent conditions under which it is believed that nearly all workers may be exposed day after day with no adverse effect. TLVs are advisory exposure guidelines, not legal standards, that are based on evidence from industrial experience, animal studies, or human studies when they exist. There are three different types of TLVs: Time Weighted Average (TLV-TWA), Short Term Exposure Limit (TLV-STEL), and Ceiling (TLV-C).

Time Weighted Average (TLV-TWA): average time, over a given work period (for example, 8-hour workday), of a person's exposure to a chemical or an agent. The average is determined by sampling for the contaminant throughout the time period.

Toxicity: potential of a substance to exert a harmful effect on humans or animals and a description of the effect and the conditions or concentration under which the effect takes place

Trade name: commercial name or trademark by which a chemical is known. One chemical may have a variety of trade names depending on the manufacturers or distributors involved

Upper Explosive Limit (UEL): highest concentration (expressed in percent of vapor or gas in the air by volume) of a substance that will burn or explode when an ignition source is present. Theoretically, above this limit, the mixture is said to be too "rich" to support combustion. The difference between the LEL and the UEL constitutes the flammable range or explosive range of a substance. That is, if the LEL is 1 ppm and the UEL is 5 ppm, then the explosive range of the chemical is 1ppm to 5 ppm.

Vapor: gaseous form of substances that are normally in the liquid or solid state (at normal room temperature and pressure). Vapors evaporate into the air from liquids, such as solvents. Solvents with low boiling points will evaporate readily.

* This glossary was prepared by excerpting selected terms and definitions from the Glossary (Appendix D), 1161-1234, in *Fundamentals of Industrial Hygiene* (Second Edition), edited by Julian B. Olishifski.

I. Web Resources

NPS Occupational Safety and Health Program: <<http://www.nps.gov/riskmgmt>>. (Director's Order #50B and Reference Manual 50B are also available through a link on this page.)

Department of Interior Manual, Part 485 Safety and Occupational Health Program: <http://www.nps.gov/riskmgmt/act_man.htm>.

AIC Health and Safety Guides: <<http://palimpsest.stanford.edu/aic/health/>>.

Conservation OnLine, Health and Safety Links: <<http://palimpsest.stanford.edu/bytopic/health/>>.

Environmental Protection Agency: <<http://www.epa.gov/>>.

ErgoWeb: <<http://ergoweb.com/Pub/ewhome.html>>.

National Institute for Occupational Safety and Health: <<http://www.cdc.gov/niosh/homepage.html>>.

Occupational Safety and Health Organization (OSHA), Department of Labor: <<http://www.osha.gov/>>.

OSHA information on respiratory protection: <<http://www.osha-slc.gov/SLTC/respiratoryprotection/index.html>>.

The Physical and Theoretical Chemistry Laboratory, Oxford University, Guide to Gloves:
<<http://physchem.ox.ac.uk/MSDS/glovesbychemical.html>>.

J. Selected Bibliography

American Institute for Conservation Health and Safety Committee. "Biological Monitoring in the Workplace." *AIC News* 24, no. 6 (1999).

Center for Occupational Hazards: Data Sheets:

"Safe Pest Control Procedures for Museum Collections" (1983).

"A Health and Safety Program for Conservation Laboratories" (1985).

"Emergency Plans for Museum Conservation Laboratories" (1985).

"Ventilation for Conservation Laboratories" (1985).

"Fire Prevention in the Conservation Laboratory" (1985).

"Solvents in Museum Conservation Labs" (1985).

"Chemical Storage and Disposal in the Conservation Lab" (1985).

Chure, Dan. "Fossil Vertebrates as Radon Sources: Health Update." *Conserve O Gram* 2/5. Washington, D.C.: National Park Service, 1993.

Clark, Nancy, Thomas Cutter, and Jean-Ann McCrane. *Ventilation: A Practical Guide*. New York: New York Center for Occupational Hazards, 1984.

Cumberland, Donald C. "Installing the Retrofit Gasket Kit." *Conserve O Gram* 4/3. Washington, D. C.: National Park Service, 1993.

Day, Nancy Raines. *Back to Backs: A Guide to Preventing Back Injury*. Daly City, Calif.: Kranes Communications, 1984.

Hawks, Catherine A., and Stephen L. Williams. "Arsenic in Natural History Collections." *Leather Conservation News* 2, no. 2 (1986). Austin, Texas: Texas Memorial Museum: 1-4.

Howie, F., ed. *Safety in Museums and Galleries*. London/Boston: Butterworth and Co. (Publishers) Limited, 1987.

Knapp, Anthony M. "Hazardous Materials Health and Safety Update." *Conserve O Gram* 2/1. Washington, D.C.: National Park Service, 1993.

_____. "Ethylene Oxide Health and Safety Update." *Conserve O Gram* 2/2. Washington, D.C.: National Park Service, 1993.

_____. "Arsenic Health and Safety Update." *Conserve O Gram* 2/3. Washington, D.C.: National Park Service, 1993.

_____. "Dichlorvos (Vapona) Update." *Conserve O Gram* 2/4. Washington, D.C.: National Park Service, 1993.

Kondratas, Ramunas. "The Preservation and Disposition of Hazardous Substances and Controlled Drugs." *Caduceus*, Autumn 1991, 55062.

Lab Safety Supply. *Safety and Industrial Supplies*. Janesville, Wisc.: Lab Safety Supply, 1997.

- Lewis, Richard J., Sr., ed. *Rapid Guide to Hazardous Chemicals in the Workplace*. 4th ed. New York: Van Nostrand Reinhold, 2000.
- MacLeish, A. Bruce. *The Care of Antiques and Historical Collections*. Nashville, Tenn.: American Association for State and Local History, 1985.
- McCann, Michael. *Artist Beware*. 2d ed. New York: Lyons Press, 1993.
- _____. *Health Hazards Manual for Artists*. New York: Lyons Press, 1994.
- McGiffin, Robert F., Jr. "Health Hazards and Safety Practices." In *Furniture Care and Conservation*. Nashville, Tenn.: American Association for State and Local History, 1983.
- _____. "Health and Safety in the Museum Workplace." *Museum News* 64, no. 2 (1985): 36-43.
- Merritt, Jane. "Mold and Mildew: Prevention of Microorganism Growth in Museum Collections." *Conserve O Gram* 3/4. Washington, D.C.: National Park Service, 1993.
- Montgomery, Allan L. "Caring for Historic Longarms: Storage and Handling Requirements." *Conserve O Gram* 10/1. Washington, D.C.: National Park Service, 1999.
- National Safety Council. *The Facts About the Hazard Communication Standard: A Guidebook*. Chicago, Ill.: National Safety Council, 1985.
- Olishifski, Julian B., ed. *Fundamentals of Industrial Hygiene*. 2d ed. Chicago: National Safety Council, 1979.
- Rossol, Monona. Revised OSHA Standard Affects Museums, Conservation Labs and Schools Information Sheet. New York: Arts, Crafts and Theater Safety (ACTS), 1987.
- _____. *The Artist's Complete Health & Safety Guide*. New York: Allworth Press, 1994.
- Roueche, Berton. "Annals of Medicine-Cinnabar." *The New Yorker* (December 8, 1986): 94-102.
- Sease, Catherine. "Safety." In *A Conservation Manual for the Field Archeologist*. University of California at Los Angeles: Institute of Archeology, 1987.
- Shaw, Susan D., and Monona Rossol. *Overexposure: Health Hazards in Photography: Everything You Need to Know about Photographic Materials and Processes to Make Your Workplace Safe and Comply with United States and Canadian Right-to-Know Laws*. New York: Allworth Press, 1991.
- Suits, Linda Norbut. "Hazardous Materials in Your Collection." *Conserve O Gram* 2/10. Washington, D.C.: National Park Service, 1998.
- U.S. Environmental Protection Agency (EPA). *Citizen's Guide to Pest Control and Pesticide Safety*. Washington, D.C.: Environmental Protection Agency, Office of Pesticide Programs, 1995.
- _____. *Understanding the Hazardous Waste Rules: A Handbook for Small Businesses—1996 Update*. Washington, D.C.: Environmental Protection Agency, Office of Solid Waste, 1996.
- _____. *A Citizen's Guide to Radon: The Guide to Protecting Yourself and Your Family from Radon*. 2d ed. Washington, D.C.: Environmental Protection Agency, Office of Air and Radiation, 1992.
- _____. *Consumer's Guide to Radon Reduction: How to Reduce Radon Levels in Your Home*. Washington, D.C.: Environmental Protection Agency, Office of Air and Radiation, 1992.

Vogt O'Connor, Diane. "Health and Safety Risks of Asbestos." *Conserve O Gram* 2/11. Washington, D.C.: National Park Service, 1999.

Waller, Robert, Katherine Andrew, and Jean Tétreault. "Survey of Gaseous Pollutant Concentration Distributions in Mineral Collections." *Collection Forum* 14, Nos. 1-2 (2000).

K. List of Figures

Figure 11.1. Ventilation chart	11:34
Figure 11.2. Sample Material Safety Data Sheet (MSDS).....	11:35
Figure 11.3. Material Safety Data Sheet for Formaldehyde Solution.....	11:37
Figure 11.4. The NFPA Hazard Symbol and Key to Color Code and Numbering System	11:45

Dilution Ventilation	
<i>Advantages</i>	<i>Disadvantages</i>
<ul style="list-style-type: none"> • low equipment and installation costs 	<ul style="list-style-type: none"> • does not eliminate exposure to contaminated area
<ul style="list-style-type: none"> • effective control for small amounts of low and medium toxicity solvents 	<ul style="list-style-type: none"> • should not be used for high toxicity vapors and gases
<ul style="list-style-type: none"> • effective control for flammable and combustible gases and vapors 	<ul style="list-style-type: none"> • should not be used for large amounts of gases and vapors
<ul style="list-style-type: none"> • requires little maintenance 	<ul style="list-style-type: none"> • ineffective for particulates (dust, metal particles, metal fumes)
	<ul style="list-style-type: none"> • requires large volumes of heated or cooled make-up air
	<ul style="list-style-type: none"> • not effective for handling surges of gases or irregular emissions
	<ul style="list-style-type: none"> • people working close to contaminant source can still have large exposures
Local Exhaust Ventilation	
<i>Advantages</i>	<i>Disadvantages</i>
<ul style="list-style-type: none"> • captures contaminants at source and removes them from workplace 	<ul style="list-style-type: none"> • system design and installation can be expensive
<ul style="list-style-type: none"> • can handle all types of contaminants, including dusts, metal fumes, etc. 	<ul style="list-style-type: none"> • requires regular cleaning, inspection and maintenance
<ul style="list-style-type: none"> • requires small amounts of make-up air since uses low exhaust volumes 	
<ul style="list-style-type: none"> • low on-going energy costs because of low amounts of make-up air 	
<ul style="list-style-type: none"> • only alternative for high toxicity airborne materials 	

Figure 11.1. Comparison of Dilution and Local Exhaust Ventilation (after Clark, et. al., 1984).

Material Safety Data Sheet

May be used to comply with
OSHA's Hazard Communication Standard,
29 CFR 1910.1200. Standard must be Form Approved
consulted for specific requirements. OMB No. 1218-0072

U.S. Department of Labor

Occupational Safety and Health Administration
(Non-Mandatory Form)



IDENTITY (As Used on Label and List)	Emergency Telephone Number
--------------------------------------	----------------------------

Section I

Manufacturer's Name	Emergency Telephone Number
Address (Number, Street, City, State, and ZIP Code)	Telephone Number for Information
	Date Prepared
	Signature of Preparer (optional)

Section II - Hazard Ingredients/Identity Information

Hazardous Components (Specific Chemical Identity; Common Names(s))	OSHA PEL	ACGIH TLV	Other limits Recommended	% (optional)

Section III - Physical/Chemical Characteristics

Boiling Point		Specific Gravity (H ₂ O = 1)	
Vapor Pressure (mm Hg.)		Melting Point	
Vapor Density (AIR = 1)		Evaporation Rate (Butyl Acetate = 1)	
Solubility in Water			
Appearance and Odor			

Section IV - Fire and Explosion Hazard Data

Flash Point (Method Used)	Flammable Limits	LEL	UEL
Extinguishing Media			
Special Fire Fighting Procedures			
Unusual Fire and Explosion Hazards			

(Reproduce locally)

OSHA 174, Sept. 1985

Figure 11.2. Sample Material Safety Data Sheet

Section V - Reactivity Data

Stability	Unstable		Conditions to Avoid
	Stable		
Incompatibility (<i>Materials to Avoid</i>)			
Hazardous Decomposition or Byproducts			
Hazardous Polymerization	May Occur		Conditions to Avoid
	Will Not Occur		

Section VI – Health Hazard Data

Route(s) of Entry:	Inhalation?	Skin?	Ingestion?
Health Hazards (<i>Acute and Chronic</i>)			
Carcinogenicity:	NTP?	IARC Monographs?	OSHA Regulated?
Signs and Symptoms of Exposure			
Medical Conditions Generally Aggravated by Exposure			
Emergency and First Aid Procedures			

Section VII - Precautions for Safe Handling and Use

Respiratory Protection (<i>Specify Type</i>)			
Ventilation	Local Exhaust	Special	
	Mechanical (<i>General</i>)	Other	
Protective Gloves		Eye Protection	
Other Protective Clothing or Equipment			
Work/Hygienic Practices			

Figure 11.2. Sample Material Safety Data Sheet (cont.)



Material Safety Data Sheet

Formaldehyde Solution 37%

ACC# 50002

Section 1 - Chemical Product and Company Identification

MSDS Name: Formaldehyde Solution 37%

Catalog Numbers: S74337, S74338, S80018-2, BP530-25, BP530-500, BP53025, BP531-25, BP531-500, F75P20, F75P4, F77 20, F77 200, F7720, F77200, F77200LC, F7720LC, F77P 20, F77P 4, F77P20, F77P4, F79 1, F79 20, F79 200, F79 4, F79 500, F791, F7920, F79200, F794, F79500, F79J4, F79P 20, F79P 4, F79P20, F79P4, NC9475399, S74337MF, S74338MF

Synonyms: None.

Company Identification:

Fisher Scientific
1 Reagent Lane
Fair Lawn, NJ 07410

For information, call: 201-796-7100

Emergency Number: 201-796-7100

For CHEMTREC assistance, call: 800-424-9300

For International CHEMTREC assistance, call: 703-527-3887

Section 2 - Composition, Information on Ingredients

CAS#	Chemical Name	Percent	EINECS/ELINCS
50-00-0	Formaldehyde	37	200-001-8
67-56-1	Methyl alcohol	15	200-659-6
7732-18-5	Water	48	231-791-2
Not avail.	Odor mask	0.0-1.1	unlisted

Hazard Symbols: T

Risk Phrases: 10 23/24/25 34 40 43

Section 3 - Hazards Identification

EMERGENCY OVERVIEW

Appearance: not available. Flash Point: 50 deg C. **Danger! Flammable liquid.** May cause allergic skin reaction. This substance has caused adverse reproductive and fetal effects in animals. May cause central nervous system depression. Cannot be made non-poisonous. May cause liver and kidney damage. Causes eye and skin irritation. Causes digestive and respiratory tract irritation. May be fatal or cause blindness if swallowed. Contains formaldehyde. Respiratory sensitizer. Potential cancer hazard. Vapor harmful.

Target Organs: Kidneys, central nervous system, liver.

Figure 11.3. Material Safety Data Sheet for Formaldehyde Solution (Reproduced by permission of Fisher Scientific.)

Potential Health Effects

Eye: Causes eye irritation. May cause chemical conjunctivitis and corneal damage.

Skin: Causes skin irritation. May cause skin sensitization, an allergic reaction, which becomes evident upon re-exposure to this material. May cause cyanosis of the extremities.

Ingestion: May be fatal or cause blindness if swallowed. Causes gastrointestinal irritation with nausea, vomiting and diarrhea. May cause liver and kidney damage. May cause central nervous system depression, characterized by excitement, followed by headache, dizziness, drowsiness, and nausea. Advanced stages may cause collapse, unconsciousness, coma and possible death due to respiratory failure. May cause central nervous system depression.

Inhalation: Inhalation of high concentrations may cause central nervous system effects characterized by headache, dizziness, unconsciousness and coma. Causes respiratory tract irritation. May cause asthmatic attacks due to allergic sensitization of the respiratory tract. Aspiration may lead to pulmonary edema. Vapors may cause dizziness or suffocation. May cause burning sensation in the chest.

Chronic: Repeated exposure may cause skin discoloration and thickening and nail decay. Repeated inhalation is associated with nasal and nasopharyngeal cancer.

Section 4 - First Aid Measures

Eyes: Flush eyes with plenty of water for at least 15 minutes, occasionally lifting the upper and lower eyelids. Get medical aid immediately. Do NOT allow victim to rub or keep eyes closed.

Skin: Immediately flush skin with plenty of soap and water for at least 15 minutes while removing contaminated clothing and shoes. Get medical aid if irritation develops or persists. Wash clothing before reuse. Destroy contaminated shoes.

Ingestion: Do NOT induce vomiting. If victim is conscious and alert, give 2-4 cupfuls of milk or water. Never give anything by mouth to an unconscious person. Get medical aid immediately.

Inhalation: Get medical aid immediately. Remove from exposure to fresh air immediately. If not breathing, give artificial respiration. If breathing is difficult, give oxygen.

Notes to Physician: Treat symptomatically and supportively.

Section 5 - Firefighting Measures

General Information: As in any fire, wear a self-contained breathing apparatus in pressure-demand, MSHA/NIOSH (approved or equivalent), and full protective gear. Water runoff can cause environmental damage. Dike and collect water used to fight fire. Vapors may form an explosive mixture with air. Vapors can travel to a source of ignition and flash back. Will burn if involved in a fire. Use water spray to keep fire-exposed containers cool. Containers may explode in the heat of a fire. Flammable Liquid.

Figure 11.3. Material Safety Data Sheet for Formaldehyde Solution (cont.) (Reproduced by permission of Fisher Scientific.)

Extinguishing Media: For small fires, use dry chemical, carbon dioxide, water spray or alcohol-resistant foam. For large fires, use water spray, fog, or alcohol-resistant foam. Use water spray to cool fire-exposed containers. Water may be ineffective. Do NOT use straight streams of water.

Section 6 - Accidental Release Measures

General Information: Use proper personal protective equipment as indicated in Section 8.
Spills/Leaks: Absorb spill with inert material, (e.g., dry sand or earth), then place into a chemical waste container. Avoid runoff into storm sewers and ditches, which lead to waterways. Clean up spills immediately, observing precautions in the Protective Equipment section. Remove all sources of ignition. Use a spark-proof tool. Provide ventilation. A vapor suppressing foam may be used to reduce vapors.

Section 7 - Handling and Storage

Handling: Wash thoroughly after handling. Remove contaminated clothing and wash before reuse. Use only in a well-ventilated area. Ground and bond containers when transferring material. Use spark-proof tools and explosion proof equipment. Avoid contact with eyes, skin, and clothing. Empty containers retain product residue, (liquid and/or vapor), and can be dangerous. Keep container tightly closed. Avoid contact with heat, sparks and flame. Avoid ingestion and inhalation. Do not pressurize, cut, weld, braze, solder, drill, grind, or expose empty containers to heat, sparks or open flames.

Storage: Keep away from heat, sparks, and flame. Keep away from sources of ignition. Store in a cool, dry, well-ventilated area away from incompatible substances. Flammables-area. Keep containers tightly closed.

Section 8 - Exposure Controls, Personal Protection

Engineering Controls: Facilities storing or utilizing this material should be equipped with an eyewash facility and a safety shower. Use adequate general or local exhaust ventilation to keep airborne concentrations below the permissible exposure limits.

Exposure Limits

Chemical Name	ACGIH	NIOSH	OSHA - Final PELs
Formaldehyde	C 0.3 ppm	0.016 ppm TWA; NIOSH Potential Occupational Carcinogen - see Appendix A Potential NIOSH carcinogen.	0.75 ppm TWA PEL; 2 ppm STEL; 0.5 ppm TWA action leve
Methyl alcohol	200 ppm; 250 ppm STEL; skin - potential for cutaneous absorption	200 ppm TWA; 260 mg/m ³ TWA 6000 ppm IDLH	200 ppm TWA; 260 mg/m ³ TWA
Water	none listed	none listed	none listed

Figure 11.3. Material Safety Data Sheet for Formaldehyde Solution (cont.) (Reproduced by permission of Fisher Scientific.)

OSHA Vacated PELs: Formaldehyde: 3 ppm TWA (unless specified in 1910.1048) Methyl alcohol: 200 ppm TWA; 260 mg/m³ TWA Water: No OSHA Vacated PELs are listed for this chemical.

Personal Protective Equipment

Eyes: Wear appropriate protective eyeglasses or chemical safety goggles as described by OSHA's eye and face protection regulations in 29 CFR 1910.133 or European Standard EN166.

Skin: Wear appropriate protective gloves to prevent skin exposure.

Clothing: Wear appropriate protective clothing to prevent skin exposure.

Respirators: Follow the OSHA respirator regulations found in 29CFR 1910.134 or European Standard EN 149. Always use a NIOSH or European Standard EN 149 approved respirator when necessary.

Section 9 - Physical and Chemical Properties

Physical State: Liquid

Appearance: not available

Odor: None reported

pH: Not available.

Vapor Pressure: Not available.

Vapor Density: >1.0

Evaporation Rate:Not available.

Viscosity: Not available.

Boiling Point: 212 deg F

Freezing/Melting Point:32 deg F

Decomposition Temperature:Not available.

Autoignition Temperature: Not applicable.

Flash Point: 50 deg C (122.00 deg F)

NFPA Rating: Not published.

Explosion Limits, Lower:Not available.

Upper: Not available.

Solubility: soluble in water

Specific Gravity/Density:Not available.

Molecular Formula:Mixture

Molecular Weight:Not available

Section 10 - Stability and Reactivity

Chemical Stability: Stable under normal temperatures and pressures.

Conditions to Avoid: Incompatible materials, ignition sources, excess heat, oxidizers.

Incompatibilities with Other Materials: Strong oxidizing agents.

Hazardous Decomposition Products: Carbon monoxide, oxides of phosphorus, irritating and toxic fumes and gases, carbon dioxide, toxic fumes of sodium oxide.

Hazardous Polymerization: Has not been reported.

Figure 11.3. Material Safety Data Sheet for Formaldehyde Solution (cont.) (Reproduced by permission of Fisher Scientific.)

Section 11 - Toxicological Information

RTECS#:

CAS# 50-00-0: LP8925000

CAS# 67-56-1: PC1400000

CAS# 7732-18-5: ZC0110000

LD50/LC50:

CAS# 50-00-0:

Inhalation, mouse: LC50 = 400 mg/m³/2H;

Inhalation, rat: LC50 = 203 mg/m³;

Oral, mouse: LD50 = 42 mg/kg;

Oral, rat: LD50 = 100 mg/kg;

Skin, rabbit: LD50 = 270 mg/kg; <BR.

CAS# 67-56-1:

Inhalation, rat: LC50 = 64000 ppm/4H;

Oral, mouse: LD50 = 7300 mg/kg;

Oral, rabbit: LD50 = 14200 mg/kg;

Oral, rat: LD50 = 5628 mg/kg;

Skin, rabbit: LD50 = 15800 mg/kg; <BR.

CAS# 7732-18-5:

Oral, rat: LD50 = >90 mL/kg; <BR.

Carcinogenicity:

CAS# 50-00-0:

ACGIH: A2 - suspected human carcinogen

California: carcinogen; initial date 1/1/88

NIOSH: occupational carcinogen

NTP: Suspect carcinogen

OSHA: Possible Select carcinogen

IARC: Group 2A carcinogen **CAS# 67-56-1:** Not listed by ACGIH, IARC, NIOSH, NTP, or OSHA. **CAS# 7732-18-5:** Not listed by ACGIH, IARC, NIOSH, NTP, or OSHA.

Epidemiology: No data available.

Teratogenicity: No data available.

Reproductive Effects: No data available.

Neurotoxicity: No data available.

Mutagenicity: No data available.

Other Studies: No data available.

Section 12 - Ecological Information

Ecotoxicity: Not available.

Environmental Fate: Not available.

Physical/Chemical: Not available.

Other: Not available.

Figure 11.3. Material Safety Data Sheet for Formaldehyde Solution (cont.) (Reproduced by permission of Fisher Scientific.)

Section 13 - Disposal Considerations

Chemical waste generators must determine whether a discarded chemical is classified as a hazardous waste. US EPA guidelines for the classification determination are listed in 40 CFR Parts 261.3. Additionally, waste generators must consult state and local hazardous waste regulations to ensure complete and accurate classification.

RCRA P-Series: None listed.

RCRA U-Series: CAS# 50-00-0: waste number U122. CAS# 67-56-1: waste number U154; (Ignitable waste).

Section 14 - Transport Information

	US DOT	IATA	RID/ADR	IMO	Canada TDG
Shipping Name:	FORMALDEHYDE, SOLUTIONS, FLAMMABLE				No information available.
Hazard Class:	3				
UN Number:	UN1198				
Packing Group:	III				

Section 15 - Regulatory Information

US FEDERAL

TSCA

CAS# 50-00-0 is listed on the TSCA inventory.

CAS# 67-56-1 is listed on the TSCA inventory.

CAS# 7732-18-5 is listed on the TSCA inventory.

Health & Safety Reporting List

None of the chemicals are on the Health & Safety Reporting List.

Chemical Test Rules

None of the chemicals in this product are under a Chemical Test Rule.

Section 12b

None of the chemicals are listed under TSCA Section 12b.

TSCA Significant New Use Rule

None of the chemicals in this material have a SNUR under TSCA.

SARA

Section 302 (RQ)

CAS# 50-00-0: final RQ = 100 pounds (45.4 kg) CAS# 67-56-1: final RQ = 5000 pounds (2270 kg)

Section 302 (TPQ)

CAS# 50-00-0: TPQ = 500 pounds; RQ = 100 pounds (does not meet toxicity criteria but because of high production volume and recognized toxicity is considered a chemical of concern)

Figure 11.3. Material Safety Data Sheet for Formaldehyde Solution (cont.) (Reproduced by permission of Fisher Scientific.)

SARA Codes

CAS # 50-00-0: acute, chronic. CAS # 67-56-1: acute, flammable.

Section 313

This material contains Formaldehyde (CAS# 50-00-0, 37%), which is subject to the reporting requirements of Section 313 of SARA Title III and 40 CFR Part 373. This material contains Methyl alcohol (CAS# 67-56-1, 15%), which is subject to the reporting requirements of Section 313 of SARA Title III and 40 CFR Part 373.

Clean Air Act:

CAS# 50-00-0 is listed as a hazardous air pollutant (HAP). CAS# 67-56-1 is listed as a hazardous air pollutant (HAP). This material does not contain any Class 1 Ozone depleters. This material does not contain any Class 2 Ozone depleters.

Clean Water Act:

CAS# 50-00-0 is listed as a Hazardous Substance under the CWA. None of the chemicals in this product are listed as Priority Pollutants under the CWA. None of the chemicals in this product are listed as Toxic Pollutants under the CWA.

OSHA:

CAS# 50-00-0 is considered highly hazardous by OSHA.

STATE

CAS# 50-00-0 can be found on the following state right to know lists: California, New Jersey, Florida, Pennsylvania, Minnesota, Massachusetts.

CAS# 67-56-1 can be found on the following state right to know lists: California, New Jersey, Florida, Pennsylvania, Minnesota, Massachusetts.

CAS# 7732-18-5 is not present on state lists from CA, PA, MN, MA, FL, or NJ.

The following statement(s) is(are) made in order to comply with the California Safe Drinking Water Act: WARNING: This product contains Formaldehyde, a chemical known to the state of California to cause cancer. California No Significant Risk Level: CAS# 50-00-0: no significant risk level = 40 ug/day

European/International Regulations**European Labeling in Accordance with EC Directives****Hazard Symbols:**

T

Risk Phrases:

R 10 Flammable. R 23/24/25 Toxic by inhalation, in contact with skin and if swallowed. R 34 Causes burns. R 40 Possible risks of irreversible effects. R 43 May cause sensitization by skin contact.

Safety Phrases:

S 26 In case of contact with eyes, rinse immediately with plenty of water and seek medical advice. S 36/37 Wear suitable protective clothing and gloves. S 45 In case of accident or if you feel unwell, seek medical advice immediately (show the label where possible). S 51 Use only in well-ventilated areas.

WGK (Water Danger/Protection)

CAS# 50-00-0: 2

CAS# 67-56-1: 1

CAS# 7732-18-5: No information available.

Figure 11.3. Material Safety Data Sheet for Formaldehyde Solution (cont.) (Reproduced by permission of Fisher Scientific.)

Canada

CAS# 50-00-0 is listed on Canada's DSL/NDSL List.

CAS# 67-56-1 is listed on Canada's DSL/NDSL List.

CAS# 7732-18-5 is listed on Canada's DSL/NDSL List.

This product has a WHMIS classification of B2, D1A, D2B.

CAS# 50-00-0 is not listed on Canada's Ingredient Disclosure List.

CAS# 67-56-1 is not listed on Canada's Ingredient Disclosure List.

CAS# 7732-18-5 is not listed on Canada's Ingredient Disclosure List.

Exposure Limits

CAS# 50-00-0: OEL-ARAB Republic of Egypt: TWA 2 ppm (3 mg/m³) OEL-AUSTRALIA: TWA 1 ppm (1.5 mg/m³); STEL 2 ppm (3 mg/m³); CAR OEL-BELGIUM: TWA 1 ppm (1.2 mg/m³); STEL 2 ppm (2.5 mg/m³); CAR OEL-CZECHOSLOVAKIA: TWA 0.5 mg/m³; STEL 1 mg/m³ OEL-DENMARK: STEL 0.3 ppm (0.4 mg/m³); Carcinogen OEL-FINLAND: STEL 1 ppm (1.3 mg/m³); Skin OEL-FRANCE: STEL 2 ppm (3 mg/m³) OEL-GERMANY: TWA 0.5 ppm (0.6 mg/m³); Carcinogen OEL-HUNGARY: STEL 0.6 mg/m³; Carcinogen OEL-JAPAN: TWA 0.5 ppm (0.61 mg/m³); Carcinogen OEL-THE NETHERLANDS: TWA 1 ppm (1.5 mg/m³); STEL 2 ppm (3 mg/m³) OEL-THE PHILIPPINES: TWA 5 ppm (6 mg/m³) OEL-POLAND: TWA 2 mg/m³ OEL-RUSSIA: TWA 0.5 ppm; STEL 0.5 mg/m³; Skin OEL-SWEDEN: TWA 0.5 ppm (0.6 mg/m³); STEL 1 ppm (1. mg/m³) OEL-SWITZERLAND: TWA 0.5 ppm (0.6 mg/m³); STEL 1 pp (1.2 mg/m³) OEL-THAILAND: TWA 3 ppm; STEL 5 ppm OEL-TURKEY: TWA 5 ppm (6 mg/m³) OEL-UNITED KINGDOM: TWA 2 ppm (2.5 mg/m³); STEL 2 ppm (2.5 mg/m³) OEL IN BULGARIA, COLOMBIA, JORDAN, KOREA check ACGIH TLV OEL IN NEW ZEALAND, SINGAPORE, VIETNAM check ACGI TLV

CAS# 67-56-1: OEL-ARAB Republic of Egypt: TWA 200 ppm (260 mg/m³); Skin OEL-AUSTRALIA: TWA 200 ppm (260 mg/m³); STEL 250 ppm; Skin OEL-BELGIUM: TWA 200 ppm (262 mg/m³); STEL 250 ppm; Skin OEL-CZECHOSLOVAKIA: TWA 100 mg/m³; STEL 500 mg/m³ OEL-DENMARK: TWA 200 ppm (260 mg/m³); Skin OEL-FINLAND: TWA 200 ppm (260 mg/m³); STEL 250 ppm; Skin OEL-FRANCE: TWA 200 ppm (260 mg/m³); STEL 1000 ppm (1300 mg/m³) OEL-GERMANY: TWA 200 ppm (260 mg/m³); Skin OEL-HUNGARY: TWA 50 mg/m³; STEL 100 mg/m³; Skin JAN9 OEL-JAPAN: TWA 200 ppm (260 mg/m³); Skin OEL-THE NETHERLANDS: TWA 200 ppm (260 mg/m³); Skin OEL-THE PHILIPPINES: TWA 200 ppm (260 mg/m³) OEL-POLAND: TWA 100 mg/m³ OEL-RUSSIA: TWA 200 ppm; STEL 5 mg/m³; Skin OEL-SWEDEN: TWA 200 ppm (250 mg/m³); STEL 250 ppm (350 mg/m³); Skin OEL-SWITZERLAND: TWA 200 ppm (260 mg/m³); STEL 400 ppm; Skin OEL-THAILAND: TWA 200 ppm (260 mg/m³) OEL-TURKEY: TWA 200 ppm (260 mg/m³) OEL-UNITED KINGDOM: TWA 200 ppm (260 mg/m³); STEL 250 ppm; Skin OEL IN BULGARIA, COLOMBIA, JORDAN, KOREA check ACGIH TLV OEL IN NEW ZEALAND, SINGAPORE, VIETNAM check ACGI TLV

Section 16 - Additional Information

MSDS Creation Date: 7/12/1999

Revision #6 Date: 8/02/2000

The information above is believed to be accurate and represents the best information currently available to us. However, we make no warranty of merchantability or any other warranty, express or implied, with respect to such information, and we assume no liability resulting from its use. Users should make their own investigations to determine the suitability of the information for their particular purposes. In no way shall Fisher be liable for any claims, losses, or damages of any third party or for lost profits or any special, indirect, incidental, consequential or exemplary damages, howsoever arising, even if Fisher has been advised of the pos

Figure 11.3. Material Safety Data Sheet for Formaldehyde Solution (cont.) (Reproduced by permission of Fisher Scientific.)

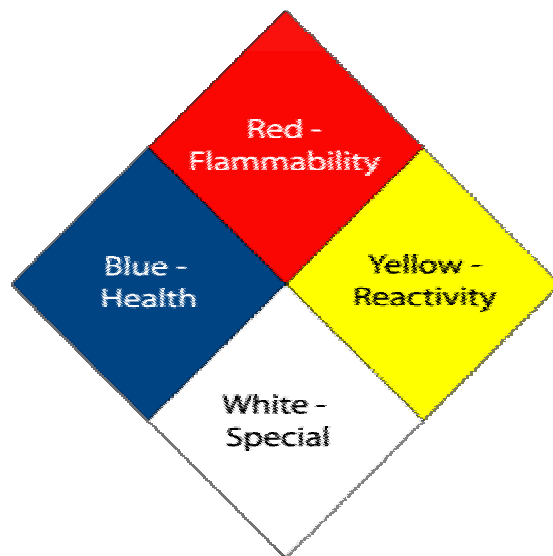

General Rating Summary

Health (Blue)

- 4 **Danger** May be fatal on short exposure. Specialized protective equipment required.
- 3 **Warning** Corrosive or toxic. Avoid skin contact or inhalation.
- 2 **Warning** May be harmful if inhaled or absorbed.
- 1 **Caution** May be irritating.
- 0 No unusual hazard.

Flammability (Red)

- 4 **Danger** Flammable gas or extremely flammable liquid.
- 3 **Warning** Flammable liquid flash point below 100° F.
- 2 **Caution** Combustible liquid flash point of 100° to 200° F.
- 1 Combustible if heated.
- 0 Not combustible.

Reactivity (Yellow)

- 4 **Danger** Explosive material at room temperature.
- 3 **Danger** May be explosive if shocked, heated under confinement, or mixed with water.
- 2 **Warning** Unstable or may react violently if mixed with water.
- 1 **Caution** May react if heated or mixed with water but not violently.
- 0 **Stable** Not reactive when mixed with water.

Special Notice Key (White)

- W Water Reactive
- OX Oxidizing Agent

Figure 11.4. The NFPA Hazard Symbol and Key to Color Code and Numbering System

Chapter 12: Curatorial Funding, Staffing, and Reporting

	<u>Page</u>
A. Overview	12:1
B. Basic Museum Program Management Issues	12:1
How do I determine my park's museum collections management needs?	12:1
What should my next steps be?	12:2
What plans are useful to identify needs and justify funding requests?	12:3
Where do I document needs?	12:4
What is a Resource Management Plan?	12:4
What is the Project Management Information System?	12:5
How can I learn more about museum management programming using PMIS?	12:5
What is the Operations Formulation System?	12:5
How does the budget process work?	12:6
C. Developing Funding Requests	12:7
What are the characteristics of a good funding request?	12:7
How do I prioritize short-term and long-term collection management needs?	12:8
How do prioritize specific projects?	12:9
How do I determine which curatorial activities can be accomplished with current staff and funding?	12:9
What kinds of activities require project funding?	12:10
What resources are available to assist in preparing funding requests?	12:10
D. Sources of Funding for Collections Management	12:11
What are the funding sources for NPS collections management?	12:11
How are base funds used?	12:11
What cultural resource project funds are available for museum collections?	12:11
What natural resources funding programs directly support museum collections?	12:13
Are there any collections management requirements for projects that generate collections?	12:13
What other NPS fund sources can be used to support museum projects?	12:13
Are there any other sources of funding for park museum programs?	12:15
How does the construction program address collections management needs?	12:15
E. Documenting Results and Performance	12:16
What is performance management?	12:16
What is strategic planning?	12:16
How does GPRA relate to NPS collection management programs?	12:17
Are there any other mission goals relevant to museum management?	12:17
How do parks estimate 1a6 goal and performance targets?	12:17
How do parks estimate 1b2D goal and performance targets?	12:17
What is the Performance Management Data System?	12:18
How do I get GPRA credit for long-term goal 1a6 and 1b2D accomplishments?	12:18
F. Staffing	12:18
What are the discipline tracks in NPS museum management programs?	12:18
What are the different occupational titles within the career tracks?	12:18
What are the qualifications for these positions?	12:19
What are the typical duties in each career area?	12:19
How do I know what staffing or career goals are needed at my park?	12:20

Are there alternative sources for staffing?.....	12:20
What is collateral duty?	12:21
G. Training and Development	12:21
How is competency defined?.....	12:22
How do I find out about training in museum management?.....	12:23
H. Resources	12:23
I. Figures.....	12:25
List of Figures	
Figure 12.1 NPS Acronyms Related to Funding, Programs, & Planning.....	12:25
Figure 12.2 Sample PMIS Project Statement	12:26
Figure 12.3 Sample OFS Statement.....	12:29

CHAPTER 12: CURATORIAL FUNDING, STAFFING, AND REPORTING

A. Overview

This chapter will introduce you to:

- **Program** documents required to obtain funding
- **Funding** categories available to pay for preservation, protection, and documentation needs
- **Staffing** requirements for collections care activities
- **Reporting** requirements related to strategic planning

Museum program management requires careful planning. For additional information on NPS museum management planning, see:

- Director's Order #2: Park Planning
 - Director's Order #24: NPS Museum Collections Management
 - Director's Order #28: Cultural Resource Management and *Cultural Resource Management Guideline* (1997)
-

B. Basic Museum Program Management Issues

1. *How do I determine my park's museum collections management needs?*

- Become familiar with the park's museum collection. Determine the following:
 - present size and scope, as well as potential growth
 - status of accountability and documentation (accession and catalog records, inventories, and similar materials)
 - security and environment of storage and exhibit spaces
 - use of the collection
 - condition of the collection

Two effective ways to get to know your collection are to:

- conduct a 100% inventory
 - refer to the Introduction section of your park's Scope of Collection Statement (SOCS) for information concerning the significance of your collection
- Update the NPS Checklist for Preservation and Protection of Museum

Collections (Museum Checklist). The Museum Checklist is a facility report that rates all museum areas (exhibit, storage, administrative) at a park according to Servicewide preservation and protection standards. Director's Order #24: NPS Museum Collections Management, requires that all parks with museum collections have an up-to-date Museum Checklist.

Having an up-to-date Museum Checklist will help you to:

- better understand the museum conditions at your park
- identify preservation and protection deficiencies
- set priorities to address preservation and protection needs

Project funding for preservation is tied to deficiencies reported on the Museum Checklist. Be sure that your Checklist is as complete and accurate as possible. Include detailed information concerning:

- the nature of each deficiency
- the action needed to address the deficiency
- accurate cost estimates (see Appendix F, Figure 1, Cost Estimates)
- cross-referencing of applicable project proposals
- any additional comments

See Appendix F: NPS Museum Collections Management Checklists, and the *ANCS User Manual*, Appendix G: Automated Checklist Program, for additional information.

- Refer to your park's Collections Management Report (CMR) to determine estimated backlogs and cataloging needs.
- Prepare a list of projects for correcting deficiencies. Divide the list into two categories:
 - needs that can be met by existing park funds and staff (such as revising the Scope of Collection Statement, obtaining pest traps for monitoring, cataloging new accessions, key control and rekeying cabinets)
 - needs that require additional funds and staff (such as building a new collections storage area, assistance with an Emergency Operations Plan, conservation treatments, installing fire and security systems, cataloging the backlog of uncataloged items)
- Prioritize both lists. Begin working on those projects that can be accomplished with existing resources.

2. *What should my next steps be?*

Refine the list of needs that require additional resources to accomplish:

- Develop accurate cost estimates. See Appendix F, Figure 1, Cost

Estimates. Consult your regional/SO curator and park maintenance staff for additional information.

- Integrate these needs into appropriate park planning documents, such as Project Management Information System (PMIS) Project Statements, Resource Management Plan (RMP), General Management Plan (GMP), Exhibit Plans, and Long-Range Interpretive Plan (LRIP).
- Ensure that collections management project statements are included in the park's Strategic and Performance Plans. Include such project statements in PMIS. Additional information may be contained in the park RMP if that document is being used (see B.5 below). Examples of project statements are:
 - Assess and Catalog Park Archival Holdings
 - Catalog Museum Objects
 - Complete Conservation Treatments
 - Conduct an Appraisal of Museum Property
 - Conduct Collection Condition Survey
 - Conduct Curatorial Training
 - Construct a New Museum Storage Facility
 - Perform Conservation Treatment
 - Prepare Collections Management Plan
 - Prepare/Implement a Historic Furnishings Report
 - Install Fire Detection and Suppression Systems
 - Install Intrusion Alarm System
 - Install Security Systems
 - Store Museum Collections
 - Upgrade Exhibits

These are but a sampling of the many potential projects that your park may require. Contact your regional/SO curator for additional assistance preparing necessary project statements.

3. *What plans are useful to identify needs and justify funding requests?*

The results and recommendations of various plans and surveys provide justification for operational support and project funding needed to develop a professional museum management program. In addition to the Collections Management Report and Museum Checklist, the most common plans and surveys used to identify collection management needs are:

- Collection Management Plan (CMP)

- Collection Condition Survey (CCS)
- Collection Storage Plan (CSP)
- Emergency Operations Plan (EOP)
- Exhibit Plan
- Integrated Pest Management (IPM) Plan
- Historic Furnishings Plan (HFP)
- Housekeeping Plan
- Security and Fire Protection Survey
- Structural Fire Plan

You also may seek funding to support these plans and surveys if they are out-of-date or do not exist for your unit.

4. *Where do I document needs?*

Programming documents are the key to obtaining funds for a project. A well-prepared document results from good planning. At the park level, the GMP, Performance Plan, Strategic Plan and RMP serve as the foundation for park resources management programs. At the Servicewide level, staff document these needs using:

- Project Management Information System (PMIS)
- Operations Formulation System (OFS)

5. *What is a Resource Management Plan?*

The Resource Management Plan (RMP) is a planning document that contains the park's natural and cultural resource management actions. The RMP includes:

- a summary of the resource status evaluating the condition and documentation of the resources and major threats to them
- an action program based on legislative and executive mandates including:
 - NPS *Management Policies* (2001)
 - NPS Director's Orders (DO): DO #24: Museum Collections Management, DO #28: Cultural Resource Management, and DO #77: Natural Resources Management
 - management zoning and provisions of related planning documents
- individual project statements

6. *What is the Project Management Information System?*

The Project Management Information System (PMIS) is a Servicewide Intranet-based database. Parks and offices use the program to manage information about requests for project funding. With PMIS, you can submit project proposals to be reviewed, approved and prioritized at park, regional, and Washington Office (WASO) levels.

Project funding is “one-time” money used to support park management goals. Some projects (design projects and others taking more than one year) can be phased, though all project funds have finite time limits.

PMIS allows staff to identify project funding needs and report accomplishments. All NPS employees can search the system. Only designated persons in each park and office can make changes and set priorities. Your regional/SO curator and your park’s administrative and maintenance staff will be familiar with PMIS and can probably answer any questions that you may have.

7. *How can I learn more about museum management programming using PMIS?*

The PMIS program is a good place to see how other parks are managing similar projects and to get ideas to enhance your proposals. After you access the system, you can use keywords within the search function to view a variety of projects. You can search any of the various funding sources, such as Backlog Cataloging, Museum Collection Preservation and Protection, or others. You can also search by park, region, state, or a variety of other criteria. The search function allows you to access project narratives, cost estimates, and information on whether projects have been funded and completed.

Another resource is your regional office staff. Each regional office has subject matter experts in various program areas who are available to assist with planning projects, writing and reviewing PMIS project statements, estimating costs, and identifying targeted funding sources. These individuals will be familiar with program criteria, and the funding process particular to your region. Your regional/SO curator will be able to assist you with your collection management projects and help direct you toward other program managers if your project is interdisciplinary.

Access PMIS on the web at: <<http://www.nps.gov/pmis>>.

8. *What is the Operations Formulation System?*

The Operations Formula System (OFS) is an Intranet-based system designed to meet the needs of parks, regions, and WASO in the development and identification of operating increases needed to support the mission and strategic plan of the NPS.

The OFS system contains all unfounded budgetary requirements of the Service for ongoing or operational needs for the next five fiscal years. OFS does not contain requests for funding of individual projects; PMIS contains all the unfounded project requirements. Both systems contain a limited amount of historical information on funded requests.

The system is interactive and normally available 24 hours a day, seven days a week. After reviews are complete, parks and other program managers should be able to prepare new requests and revise most of the existing requests on their own timetables.

All needs or requests for funding should be represented in either the OFS or PMIS system. The information contained in OFS and PMIS serves as the sole source for formulating the three formal NPS budget requests (to the Department of the Interior, the Office of Management and Budget, and the Congress). In addition, the information will serve as the official NPS response to all internal and external inquiries about unfounded budgetary needs and strategies for addressing these needs.

The superintendent, in consultation with the management staff, generally develops OFS submissions. Ask your administrative staff when the OFS call comes out, and take the opportunity to advocate for your programs if you need more staff.

You can search OFS at <<http://www.nps.gov/ofs>>.

Don't wait until the OFS call comes out to begin advocating for curatorial needs. Be sure to keep your superintendent, division chief, and administrative staff up-to-date at all times concerning museum programming needs.

9. *How does the budget process work?*

The budget process can last 21 months or more. At any given time, the NPS is engaged in activities related to three separate fiscal year budgets; one enacted by Congress and those proposed for the next two fiscal years. The proposed budgets include the next fiscal year's Appropriations Bill (not yet enacted) and the following fiscal year's NPS budget proposal.

Each fall the NPS issues a Servicewide Comprehensive Call (SCC) for project and operating increase requests. Parks, regions, and offices enter their requests through the PMIS and OFS systems. They tie their requests to their Government Performance Results Act (GPRA) goals, strategic plans, and business plans. Although requests can be added to the systems at any time, review, approval and prioritization occur in response to the schedule set by the SCC.

The WASO budget office coordinates the entire process for the NPS. Procedures vary from region to region, but the general process from the park perspective is as follows:

- Superintendents and division chiefs identify additional resources needed to operate and maintain the park. They set priorities based on recommendations from park staff.
- Regional associate directors, the regional budget office, and the regional director review the park requests (with assistance from program managers and subject matter experts). They add requests for region-wide programs and regional office staff, and then set regional priorities.
- WASO associate directors and program managers submit projects and increase requests for their office and Servicewide programs.
- The Department and Office of Management and Budget (OMB) provide initial guidance and review of the NPS budget and pass back

required changes.

- The President submits the budget to Congress.
- At the Congressional level, House and Senate Sub-Committees and Committees hold hearings to determine what will be included in the appropriations. Votes of the House and Senate result in an appropriations bill that is sent to the President for signature.

Background and current information on the NPS budget process can be found on the Web at: <<http://www.nps.gov/budget>>.

C. Developing Funding Requests

1. *What are the characteristics of a good funding request?*

A well-written request (project statement) should provide a concise description and justification, and identify expected results. Conduct research to determine how much time the project will take. Contact colleagues in other parks who have conducted similar projects, or contact your regional/SO curator and regional program specialists to help with costs estimates. When writing a project statement, answer the following questions:

- What is the project?
- Why is the project important?
- What problems, needs, or deficiencies will the project address?
- How much will the project cost?
- How will the funds be spent?
- What is the schedule for completion?

Make sure to do the following:

- Be certain that project statements address all criteria outlined in the SCC, the regional budget call and related guidance from Washington associate directors.
- Enter the eligible funding source(s) for each project in PMIS.
- Plan ahead to allow time for internal and external review of your project statement.
- Link desired results to your annual GPRA goals (see Section E. below).

See Figure 12.2 for a sample PMIS project statement and Figure 12.3 for a sample OFS statement.

Remember: The person reviewing these documents won't be familiar with the problem. Submit clear and detailed project statement to have a better chance of being approved.

2. *How do I prioritize short-term and long-term collection management needs?*

Short-term and long-term priorities depend on your park's mission, existing resources (staffing and funding), and resource management goals. Your Collection Management Plan, Museum Checklist, and Collections Management Report will help you start to identify and prioritize short-term and long-term funding needs.

Review the following park reports, surveys, and planning documents to help set priorities:

- General Management Plan (GMP)
- Development Concept Plan (DCP)

Museum Plans:

- Archival Assessments (see the *Museum Handbook*, Part II, Appendix D)
- Collection Condition Surveys (see *Museum Handbook*, Part I [MH-I], Chapter 3)
- Collection Storage Plans (see *MH-I*, Chapter 7)
- Environmental Surveys (see *MH-I*, Chapter 4)
- Emergency Operations Plan (see *MH-I*, Chapter 10)
- Fire Protection Surveys (see *MH-I*, Chapter 9, and Appendix G)
- Historic Furnishing Reports (see *Museum Handbook*, Part III, Chapter 8 [forthcoming]).
- Housekeeping Plans (see *MH-I*, Chapter 13)
- Integrated Pest Management Plan (see *MH-I*, Chapter 5)
- Security Surveys (see *MH-I*, Chapter 9, and Appendix G)
- Structural Fire Plans (see Director's Order #58: Structural Fire Management, *MH-I*, Chapter 9, and *MH-I*, Appendix G)

These reports generally provide a list of priorities in their recommendations. You can probably accomplish some of these recommendations using base funds (see Section D., below). Others will require special funding. When contracting for these reports and plans, include a requirement for a list of prioritized recommendations with funding estimates in the project Scope of Work.

Planning documents developed in other park divisions, such as Interpretation, History, and Maintenance will often have an impact on collections management. Examples are:

- Archeological Overview and Assessment
- Long-Range Interpretive Plan
- Historic Resource Studies
- Historic Structures Reports

Review these documents to ensure that applicable collections management needs are addressed. Also, be sure to brief these same divisions on museum activities that may affect their operations, or if you require their assistance in implementing your programs.

3. *How do I prioritize specific projects?*

You may want to ask your regional/SO curator to help you identify priorities for your park. In some cases, projects need to take place in a specific progression. For example, a condition assessment is needed prior to conservation treatment, and a security survey is needed prior to the installation of a security system. For additional information concerning the relationships among the various planning documents see Chapter 3: Preservation: Getting Started, Chapter 9: Museum Collections Security and Fire Protection, Chapter 10: Emergency Planning, Chapter 13: Museum Housekeeping, Appendix F: NPS Collections Management Checklists, and Appendix G: Protection of National Park Service Museum Collections.

4. *How do I determine which curatorial activities can be accomplished with current staff and funding?*

Parks with museum collections have a curator, museum specialist, museum technician, archivist, archives technician, or a person assigned collection management responsibilities as a collateral duty. Ongoing tasks should be conducted by park staff with base funds. Examples include:

- routine housekeeping in exhibit and storage areas
- monitoring for pest activity
- monitoring environmental conditions
- accessioning newly acquired objects
- cataloging objects in ANCS+
 - new acquisitions
 - backlog acquired since 1987 (pre-1987 backlog items are eligible for Backlog Cataloging funds)
 - re-cataloging
- completing and updating the Museum Checklist and Collections Management Report
- answering research requests

- developing project statements for improvements to the park's collections management program
- providing access to collections, such as mounting new exhibits (including Web-based) or assisting researchers

Document the ongoing curatorial workload, accomplishments, and related costs as follows:

- identify the major museum collections management work activities that need to be done
- maintain a general accounting of the hours spent on each major activity
- assess whether the work was fully, partially, or not completed
- keep a record of the costs of curatorial supplies and materials

Use these data annually to help identify any funding needed to fully complete the major work activities. This information supports OFS requests for increased park base funding.

5. *What kinds of activities require project funding?*

Additional funds are often required to prepare planning documents, surveys, or reports. Other special projects requiring funding include:

- designing and constructing new storage facilities
- improving existing storage
- contracting for exhibit design and fabrication
- contracting for Web-based exhibit design, production, and launch
- obtaining conservation treatment
- installing environmental systems
- contracting for cataloging

6. *What resources are available to assist in preparing funding requests?*

Obtain assistance in preparing documents by:

- researching successfully funded projects in the PMIS and OFS databases
- requesting assistance from your regional/SO curator
- contacting colleagues who have completed similar park projects

D. Sources of Funding for Collections Management

1. *What are the funding sources for NPS collections management?*

NPS funding is divided into two categories:

- Park Operations (also called Park Base)
- Project Funds

2. *How are base funds used?*

Base funds should support ongoing requirements for collection management, including curatorial staff, clerical support, curatorial supplies and equipment, and travel to training courses and professional conferences. The park's collection management program should have a sufficient funding base to complete all major curatorial activities. Ongoing operations should not be financed with project funds.

The size, nature, and complexity of a park's museum collection are major factors in determining workload. Base funds should be directed at:

- program accountability, documentation, and record keeping
- preventive conservation for objects in storage and on exhibit
- maintenance of security and fire protection systems
- providing for access and use of the collections

Submit requests for base increases in OFS (see Section B.8).

3. *What cultural resource project funds are available for museum collections?*

Project funding is available for cultural resource projects that support the *NPS Strategic Plan* long-term goals and address museum collections. Specific funding programs are:

- **Cultural Cyclic Maintenance.** Projects include repair of a historic property, when its condition warrants, with the least degree of intervention including replacement in-kind, or replacing an entire feature in-kind when the level of deterioration or damage of materials precludes repair. For archeological sites it includes work to moderate, prevent, or arrest erosion. For museum objects it includes actions to prevent damage and to minimize deterioration by practicing preventive conservation or by performing suitable treatments on objects themselves. Such work is performed less than once a year.
- **CRPP—Cultural Resources Preservation Program Base.** Projects include inventory, evaluation, documentation, research, stabilization, and conservation of park resources, including completion of the systemwide resources databases and preparation and publication of professional reports not addressed under other funding sources. Preferred projects include those that provide basic inventory and evaluation data for planning, treatment, protection, management, and interpretation needs; provide National Register documentation; address common resource needs of multiple parks; and respond to accepted findings of the General Accounting Office (GAO) and Inspector General (IG). Projects produce archival material and sometimes

objects that must be cataloged into the museum collections and properly stored. Review cultural resource projects to ensure that these costs are included.

- **CRPP—Museum Collections Backlog Cataloging. (For Post-1987 Collections).** Projects are to catalog previously uncataloged collections. The backlog must be identified on the previous year's Collections Management Report on file with Museum Management Program (MMP), National Center for Cultural Resources. Costs should be consistent with the range of costs in the *Museum Handbook*, Part II, Appendix B. Costs at variance should be explained in the PMIS statement. This activity supports the *NPS Strategic Plan* long-term goal Ib2D. Regions should give priority to projects that commit to mounting the resulting catalog data on the *Web Catalog* and projects that catalog nitrate film that must be cataloged prior to reformatting. **Note:** These funds address the needs of the post-1987 collections acquisitions.
- **Museum Collections Backlog Cataloging. (For Pre-1987 Collections).** Projects include the cataloging of the backlog of uncataloged objects acquired prior to January 1, 1987. Projects include activities essential to cataloging, such as completing catalog worksheets, entering catalog data in the Automated National Catalog System (ANCS+), photographing objects as part of the cataloging process, and purchasing computer equipment to accomplish these tasks. The backlog must be identified on the previous year's Collections Management Report on file with the MMP. Costs should be consistent with the range of costs in the *Museum Handbook*, Part II, Appendix B. Costs at variance should be explained in the PMIS statement. This activity supports the *NPS Strategic Plan* long-term goal Ib2D.
- **CRPP—Systemwide Archeological Resources Inventory (SAIP).** Projects include archeological overviews and assessments, identification and evaluation studies, database documentation using the Archeological Sites Management Information System (ASMIS), National Register nominations and other activities consistent with program requirements, standards and priorities set forth in the *National Park Service's Systemwide Archeological Inventory Program* publication (October 1992), and the priorities established in each region's archeological inventory plan. Projects produce archival material and sometimes objects that must be cataloged into the museum collections and properly stored. Review cultural resource projects to ensure that these costs are included.
- **Museum Collections Preservation and Protection.** Projects include correcting preservation and protection deficiencies identified in each park's and center's Checklist for Preservation and Protection of Museum Collections. Parks and centers must have an up-to-date Museum Checklist on file with MMP. Costs should be consistent with the range of costs in the *Museum Handbook*, Part I, Figure F.1. Costs at variance should be explained in the PMIS statement. This activity supports the *NPS Strategic Plan* and long-term goal Ia6.
- **Park Native American Graves Protection Projects.** Projects include cultural affiliation and lineal descendent studies; consultations related

to inadvertent discoveries, repatriation, planned excavations, modifications in the Summary and Inventory, and development of Memoranda of Understanding and preparation of Written Plans of Action regarding planned excavations and inadvertent discoveries per 43 CFR 10.5 (e); updating of related ANCS+ records. For additional information see *Museum Handbook*, Part II (*MH-II*), Chapter 6: Deaccessioning, Section N, Native American Graves Protection and Repatriation Act and *Cultural Resource Management Guideline*, Appendix R, NAGPRA Compliance.

Access the current National Park Service Strategic Plan on the web at: <<http://www.nps.gov/performance>>.

4. *What natural resources funding programs directly support museum collections?*
- There are no natural resource management funds that support the curation or long-term care and maintenance of existing natural history collections. However, in accordance with Director's Order #24: NPS Museum Collections Management, you must ensure that all project budgets include funding for the basic management of any project-generated collections. Basic collections management includes cataloging, labeling, conservation, examination, treatment, specimen preparation, initial storage of objects and specimens, and organization and storage of project documentation.
5. *Are there any collections management requirements for projects that generate collections?*
- Yes, as noted above, Director's Order #24 requires all project budgets to include funding for the basic management of any project-generated collections. Archeological projects generate field records (archives) [see *MH-II*, Appendix D for additional information] and often recover objects that must be accessioned as museum collections. These field records and objects must be cataloged and stored properly for long-term preservation and access. Likewise, other resource management projects such as fire effects projects, inventorying and monitoring projects, Historic Landscape Reports, Ethnobotanical Studies, Historic Resource Studies, oral histories, Ethnographic Overview and Assessments, National Register nominations, and Historic Structure Reports generate archival collections (and may also generate objects and specimens) that must be accessioned and curated in an appropriate facility. Be sure to include adequate funding for cataloging and curation in all project cost estimates.
6. *What other NPS fund sources can be used to support museum projects?*
- Additional funding programs that you can use to support museum projects include:
- **Challenge Cost-Share.** This program provides a maximum of 50% cost-share grant to expedite and complete mutually beneficial projects with outside sources. The purpose is to increase awareness and participation by both neighboring communities and the public at large in the preservation and improvement of NPS recreational, cultural, and natural resources. Park partners include individuals, groups, companies, corporations, state and local agencies, and other non-federal entities that will donate funds, equipment, supplies, or in-kind labor to complete a park project. Projects are generally intended to be small, able to be completed in one year, and consistent with park planning documents.

- **Concessions Franchise Fees.** Fees for concessioner activities are retained entirely by the NPS (80% by the collecting park) for training, the repair and rehabilitation of facilities (including historic structures used by concessioners and NPS exhibits within concession buildings), roads, and utility systems, and other concessions-related projects.
- **Donations.** Although parks cannot solicit donations, they are authorized to accept and use donated funds to meet the purposes of the National Park Service. Use of these funds is strictly controlled, must be consistent with legislative authority, and must meet with the approval of the grantor. Individual park accounts are established for specific-purpose donations (such as a museum management account). A general donation account, not specific-purpose in nature, is also available.

Director's Order #21: Donations and Fundraising, Section 3.1 states that "...neither the NPS nor its employees has authority to solicit donations."

- **National Parks Pass.** Fees collected from the sale of the National Parks Pass (minus administrative costs) are retained by the NPS (70% by the collecting park) and are available to fund various park projects, including museum and other cultural resource management projects. Funds not retained by the collecting parks (30% of the total) are available to finance various projects at other parks that do not sell the National Parks Pass.
- **Exhibit Rehabilitation and Preservation.** Projects include the repair, rehabilitation or replacement of films, videos, and equipment and visitor center or wayside exhibits. Funding also provides for the preservation of artifacts and museum specimens, and the acquisition of historic furnishings.
- **Recreational Fee Demonstration Program.** Fees collected at participating parks are retained by the NPS (80% by the collecting park) and are immediately available to fund various park projects, including museum and other resource management projects. Funds not retained by the collecting parks (20% of the total) are available to finance various projects at other parks not involved in the Recreational Fee Demonstration Program.
- **Regular Cyclic Maintenance.** Funds are used to maintain park roads, trails, buildings, utility systems, and other facilities on a fixed periodic basis as long as the cycle is longer than one year but no longer than ten years. Budget submissions for the cyclic maintenance program are extracted from the park's ten-year cyclic maintenance program. The work may require the preparation of simple designs and specifications and is performed by contract or day labor. Funding may not be used for new construction without clearance from the regional office and WASO.
- **Repair and Rehabilitation.** Funding is used to cover the cost of repair and rehabilitation of existing facilities, roads, trails, and utility systems.

Funding may not be used for new construction without approval from the regional office and WASO.

- **Save America's Treasures.** Grants are available for preservation and/or conservation work on nationally significant intellectual and cultural artifacts and nationally significant historic structures and sites. A grant requires a dollar-for-dollar non-Federal match. The minimum grant request for collections projects is \$50,000 Federal share; the minimum grant request for historic property projects is \$250,000 Federal share. The maximum grant request for all projects is \$1 million Federal share.
- **Volunteers-in-Parks (VIP).** Funding is available for incidental expenses such as uniforms, period clothing, local travel, supplies, lodging, meals, and other direct costs chargeable to the Volunteers-in-Parks Program. **This fund also provides for the training of volunteers.**

Contact your park and regional/SO budget staff for additional information concerning project eligibility standards, criteria, and funding sources that you may utilize in support of museum projects.

7. *Are there any other sources of funding for park museum programs?*

Yes. Additional sources of potential funding include:

- Cooperating Associations
- Friends Groups
- Park Partners
- Grants

Contact your regional/SO curator for help identifying additional sources of funding.

Support, donations, and other assistance provided to the Service by cooperating associations, friends groups, park partners, and others must comply with the policies contained in Director's Order #21: Donations and Fundraising and Director's Order #32: Cooperating Associations.

8. *How does the construction program address collections management needs?*

There are several categories of facilities maintenance and construction funds that can be used to address collections management needs:

- Repair of a failing fire alarm and/or existing sprinkler system is a **Critical Health and Safety Deferred Maintenance Need** (a facility deferred maintenance need that poses a serious threat to public or employee safety or both).
- Installation of a fire alarm system in a public building where one did not previously exist is a **Critical Health and Safety Capital Improvement Need** (a condition that poses a serious threat to public or

employee safety or health and can only be reasonably abated by the construction of some capital improvement).

- Repairs to a building housing a museum collection that is threatened because of the poor building condition is a ***Critical Resource Protection Deferred Maintenance Need*** (a facility deferred maintenance that poses a serious threat to natural or cultural resources).
- Installation of a fire sprinkler system for the protection of a building or its contents is a ***Critical Resource Protection Capital Improvement Need*** (a condition that poses a serious threat to natural or cultural resources).

All construction projects must be entered in the PMIS system. Consult with regional construction professionals to develop an appropriate project statement. Estimate costs carefully and refer to cost information provided on the Construction Program Management Intranet site at: construction.den.nps.gov/html/BenchmarkCosting.htm.

E. Documenting Results and Performance

1. *What is performance management?*

Performance management ensures that established goals guide daily actions. Performance measures help us know both how effective we are in fulfilling our mission, and how efficient we are in using the least input (time, materials, dollars, and staffing) to achieve the greatest outcome (intended consequences and effects resulting from our activities). Your park will develop a mission statement and long-term and annual performance goals for all major programs, then measure and report on the actual park performance.

The Government Performance and Results Act of 1993 (GPRA) (31 USC 1115) requires federal employees to use performance management in all aspects of daily operations. The strategic planning process is the heart of performance management.

Performance management focuses on the results of efforts rather than the efforts themselves.

2. *What is strategic planning?*

Strategic planning sets goals to achieve an institution's mission. The *National Park Service Strategic Plan* implements performance management, a business system that:

- provides a Servicewide performance agreement with the public
- sets measurable goals that directly support the NPS mission
- aligns activities and human resources to accomplish the goals
- shows where the NPS can fulfill its mission with current resources and where it cannot

The *National Park Service Strategic Plan* defines success for the Service

and provides Servicewide direction. The NPS developed its strategic plan with public meetings and questionnaires, in consultation with the Office of Management and Budget, Congress, and the Department of the Interior. Each park, program, and central office also has its own strategic plan.

3. *How does GPRA relate to NPS collection management programs?*

The Servicewide Strategic Plan includes two mission goals and long-term goals that are specific to NPS museum management. Long-term goals stem from mission goals and include a date by which to achieve the goal.

- **Mission Goal Ia** states, “natural and cultural resources and associated values are protected, restored and maintained in good condition and managed with their broader ecosystem and cultural context.”

Long-term goal Ia6 states that a certain percentage of preservation and protection standards for park museum collections will be met. (For example, *By September 30, 2005, 73.4% of preservation and protection standards for park museum collections are met.*)

- **Mission Goal Ib** states, “the National Park Service contributes to knowledge about natural and cultural resources and associated values; management decisions about resources and visitors are based on adequate scholarly and scientific information.”

Long-term goal Ib2D states that the number of museum objects cataloged increases by a certain percent. (For example, *By September 30, 2005, museum objects cataloged are increased by 35.9% from 37.3 million to 50.7 million*)

4. *Are there any other mission goals relevant to museum management?*

Yes. They include:

- **Mission Goal IIa**, which states, “Visitors safely enjoy and are satisfied with the availability, accessibility, diversity, and quality of park facilities, services, and appropriate recreational opportunities.”
- **Mission Goal IIb**, which states, “Park visitors and the general public understand and appreciate the preservation of parks and their resources for this and future generations.”

5. *How do parks estimate Ia6 annual and long-term goal and performance targets?*

This goal corresponds directly to the number of standards met on the Museum Checklist. This number is reported as a percentage of standards met as compared to the number of applicable standards. You can use the Automated Checklist Program deficiency report (see the *ANCS+ User Manual*, Appendix G) to get your current status. To estimate a target, use the sum in the standards met column, and then decide which additional standards you think that you can meet. An example of a goal would be, “By September 30, 2005, 76% of applicable preservation and protection standards are met for the park’s museum collections.”

6. *How do parks estimate Ib2D annual and long-term goal and performance targets?*

This goal corresponds directly to the Collections Management Report (CMR). In your most recent CMR, check the “Objects Cataloged” total under the “Total Collection Summary for All Years.” This is how many cataloged objects you currently have. Calculate how many objects you want to catalog by the end of the current fiscal year (annual goal), subsequent years (annual goals), and at the end of five years (long-term goal).

7. *What is the Performance Management Data System?*

The Performance Management Data System (PMDS) is an Intranet database that identifies all of the agency's performance management efforts. Performance management requires that you depict the work you do in terms of measurable outcomes. PMDS records data to measure performance relative to Servicewide and park and/or program-specific long-term goals.

Parks use the Museum Checklist (ACP) and CMR in ANCS+ to submit required electronic reports to the Museum Management Program by November 1 each year. The MMP certifies the data to the Strategic Planning Office, which incorporates it into PMDS.

*For more information, access the PMDS website at:
<<http://www.nps.gov/performance/>>.*

8. *How do I get GPRA credit for long-term goal Ia6 and Ib2D accomplishments?*

Your park PMDS coordinator will report your accomplishments in relation to Goals Ia6 and Ib2D in PMDS. You need to provide the park PMDS coordinator with a copy of your **defrpt.frx** report from the ACP and a copy of your CMR so that person can enter the correct data. In PMDS, the park's data and the certified data entered in Washington should be identical since they come from the same ACP and CMR reports.

F. Staffing

1. *What are the discipline tracks in NPS museum management programs?*

There are four discipline tracks:

- Collections Management
- Curation
- Archives
- Conservation

2. *What are the different occupational titles within the career tracks?*

NPS museum management career tracks include the following nine occupational groups:

- Museum Technician (GS-1016)
- Museum Specialist (GS-1016)
- Museum Registrar (GS-1001)
- Collections Manager (GS-1015)
- Museum Curator (GS-1015)
- Archives Technician (GS-1421)
- Archives Specialist (GS-1421)

- Archivist (GS-1420)
- Museum Conservator (GS-1001)

3. *What are the qualifications for these positions?*

Refer to the list of the principal occupational series in the OPM *Qualification Standards for General Schedule Positions*, available on the web at: <<http://www.opm.gov/qualifications/sec-iii/a/num-ndx.htm>>.

4. *What are the typical duties in each career area?*

Collections Manager: Collections managers provide front-line management of collections at parks and centers. Collections managers often begin their careers as museum technicians, and may eventually move on to the:

- curator track
- conservator track

Occasionally, this path can lead to the archivist track. Typically, the collections manager will have an academic degree in museum studies, museology, archeology, natural science, or a related field.

Curator: Curators are responsible for the acquisition, documentation, preservation, and use of collections. Typically, the support office, regional, or center curator will provide technical assistance to field staff in carrying out their responsibilities. Within this track there are three separate sub-tracks or specializations:

- program management
- exhibit development
- subject matter expert

Typically, the curator will have an academic background in American studies, anthropology, history, a natural science discipline, museum studies, or a related field. Experience in addition to education is necessary at the developmental level. As their careers progress, curators should obtain additional education and experience in museum management, exhibit development, or their subject matter specialization.

Archivist: Archivists evaluate, survey, acquire, preserve, arrange, describe, use, and manage archival and manuscript collections. Such collections can include audio-visual, electronic, and textual records. Typically, archivists at the entry or developmental level have a masters degree in library science or history with a specialization in archives management. Archivists gain extra training through a combination of education and experience. They also will have considerable additional experience under the tutelage of another professional. The Society of American Archivists (SAA) and the Academy of Certified Archivists (ACA) both formally endorse archival certification and the hiring of certified archivists.

Conservator: Conservators provide specialized experience in preventive conservation and treatment of collections. Typically, conservators have graduated from a recognized conservation training program. At the entry level, conservators will have both academic training and considerable

experience in either a broad range of conservation issues or a narrowly focused group of materials

5. *How do I know what staffing or career goals are needed at my park?*

Review planning documents and work with your regional/SO curator to develop guidelines for determining the appropriate staff mix for your collection. Consider your collection's size, complexity, and uses. Be sure to build a trained museum staff adequate to your needs in order to comply with museum management requirements.

In general, for museum-related jobs such as curator (1015), museum specialist (1016), registrar (1001), and archivist (1420), the grade at which the individual acts independently is the GS-11 level. At lower grades, the incumbent requires guidance from a higher graded individual in the same series (or another museum-related classification). It's best if this higher graded person is located in the same park, but they may work in a nearby park or center, or in the regional or support office.

The classifier determines the appropriate classification and grade for a position by:

- working with the supervisor and the description of duties
- following Office of Personnel Management classification standards

Use the Resources Careers Benchmark Position Descriptions (available on the web at <http://www1.nrintra.nps.gov/careers>) to facilitate this process.

Communication is essential! Be sure that your superintendent is aware of the value and potential uses of the archival and museum collections. Stress the concept of highly visible and unique natural and cultural resources collections and documentation associated with the site's history and resources to support staffing needs. Collections should be used as a powerful outreach and public relations tool (as well as being resources themselves) while preserving the history and resources of the park.

6. *Are there alternative sources for staffing?*

Many parks use alternative sources for staffing their museum management programs. Full time museum staff may not be necessary in a park with a small collection; however, all collections require ongoing documentation, preservation, protection, and access. Alternative sources of staffing for museum management include:

- using collateral duty staff (see below)
- contracting specialized tasks or projects that can be accomplished in a given fiscal year
- establishing cooperative agreements with universities or local museums for collections storage and curatorial staffing
- recruiting volunteers and mentors

- offering internships and fellowships

Generally, cooperative agreements are formed to maintain a portion of a museum collection (e.g. archeology or entomology) that provides mutual benefit to the park and the agency or institution where the collection is housed.

Other sources of staffing include volunteers from the community and student interns. Volunteers and interns can provide assistance with:

- identifying objects and specimens
- cataloging
- photographing
- organizing storage spaces
- museum housekeeping
- assisting researchers and park staff
- conducting collections research

For volunteer programs to work effectively, park staff must provide all volunteers with proper training, supervision, and support.

7. What is collateral duty?

Collateral duty is a term used when a person has multiple and highly varied responsibilities in his/her official position description. A collateral duty is secondary to the primary duties that determine the job classification. Often collateral duties for museum management are assigned to a park ranger or a resources management specialist, such as a biologist, historian, or archeologist. Many collateral duty staff bring prior training in museum management to their positions, while others are trained on the job. Collateral duty museum staff should be trained by a full-time curator or museum specialist (GS-1015 or GS-1016), and receive ongoing guidance from a nearby park curator (at GS-11 or above) and/or the regional/SO curator.

G. Training and Development

The NPS is committed to the professional growth and continuous learning of all its employees. It provides them with a comprehensive, competency-based, and mission focused training and development program. The strength of competency-based training is that it is *outcome-based* and *learner-driven*.

The NPS Training and Development Program develops and delivers learning opportunities that provide the knowledge and skills needed by employees to better perform their jobs. These opportunities include:

- formal education

- life experiences
- traditional classroom courses and workshops
- seminars and conferences
- on-the-job experience and training
- technological enhanced learning (TEL), including:
 - self-paced computer courses
 - satellite broadcast courses

For more information on the NPS Training and Development Program, see the NPS “Learning Place” at: <<http://www.nps.gov/training>>.

1. *How is competency defined?*

Note: At present, the competencies are to be used only for training and development purposes. They should not be used for hiring and promoting employees. OPM must validate the competencies before the NPS decides how to integrate them into the full NPS Human Resources Performance Process.

The NPS Training and Development Program defines competency as follows:

- **Competency**—“a combination of knowledge, skills, and abilities in a particular career field, which, when acquired, allows a person to perform a task or function at a specifically defined level of proficiency.”
- **Essential Competency**—“a competency that forms part of the vital knowledge, skills, and abilities for an individual career field. An essential competency is critical for an employee to perform effectively at his or her level in a Career Field.”

Eight essential competencies are common to all employees in and associated with the Cultural Resources Stewardship Career Field. They are:

- Professional Discipline
- Preservation Law, Philosophy, and Practice
- Research and Inventory
- Preservation, Treatment, and Maintenance
- Program and Project Management
- Writing and Communications

- Training
- Safety

Knowledge, skills, and abilities (KSAs) are identified for each competency.

For more information on NPS museum management competencies, see the Cultural Resources Stewardship Career Field Web site: <<http://www.nps.gov/training/crs/crs.home.htm>>.

2. *How do I find out about training in museum management?*

There are a number of sources of museum management training, including:

- **Training and Development Program** develops and delivers Servicewide training and development opportunities. For further information, see the Learning Place website at: <<http://www.nps.gov/training>>.
- **Museum Management Program** works with the Training and Development Program to develop training related to new policies and procedures concerning NPS museum collections management, such as ANCS+ training.
- **Regional offices** offer training in museum management basics and ongoing professional training, including training in NPS procedures. Contact your regional employee development officer and regional/SO curator for further information.

Other museum training opportunities are presented by various local, state, and national organizations. To learn more, refer to:

- the MMP Web site at: <<http://www.cr.nps.gov/museum>> to access a monthly list of museum conferences, courses, seminars, and other opportunities.
- Appendix C: Professional Organizations
- your regional/SO curator

H. Resources

Most of the important NPS resource documents referenced in this chapter are on the Internet. See *Conserve O Gram* 1/7, Useful World Wide Web Resources.

NPS Web Resources

Cultural Resources <<http://www.cr.nps.gov>>.

The Learning Place <<http://www.nps.gov/training/nponly/npscom.htm>>.

Museum Management Program <<http://www.cr.nps.gov/museum>>.

National Park Service Strategic Plan <http://www.nps.gov/planning/NPS_strategic_plan.pdf>.

Project Management Data System <<http://www.nps.gov/performance/>>.

Project Management Information System <<http://www.nps.gov/pmis/>>.

Resources Careers <<http://www1.nrintra.nps.gov/careers/index.htm>>.

Other Web Resources

American Association of Museums <<http://www.aam-us.org/>>.

American Association of State and Local History <<http://www.aaslh.org>>.

American Institute for Conservation of Historic and Artistic Works <<http://aic.stanford.edu>>.

Campbell Center for Historic Preservation Studies <<http://www.campbellcenter.org>>.

Canadian Conservation Institute <http://www.cci-icc.gc.ca/main_e.shtml>.

Society of American Archivists <<http://www.archivists.org>>.

Special Libraries Association <<http://www.sla.org>>.

Texas Historical Commission's Winedale Museum Seminar
<<http://www.thc.state.tx.us/museums/muswinedale1.html>>.

I. Figures

General	DOC	Division of Conservation
	DSC	Denver Service Center
	HFC	Harpers Ferry Center
	MMP	Museum Management Program
	MMPC	Museum Management Program Council
Contracting	IDIQ	Indefinite Delivery Indefinite Quantity
	RFP	Request for Proposal
	RFQ	Request for Quotation
	SOW	Scope of Work
Funding Sources	BACAT	Backlog Cataloging
	CR-MAP	Cultural Resources Management Assessment Program
	CRPP	Cultural Resource Preservation Program
	CYCC	Cultural Cyclic
	MCPP	Museum Collection Preservation and Protection
Planning and Budget	GPRA	Government Performance and Results Act
	OFS	Operations Formulation System
	PMDS	Project Management Data System
	PMIS	Project Management Information System
Recurring Museum Management Reports	ACP	Automated Checklist Program (Museum Checklist)
	AIP	Automated Inventory Program
	CMR	Collections Management Report
Program Planning	CBA	Choosing By Advantage
	CCS	Collection Condition Survey
	CIP	Comprehensive Interpretive Plan
	CLR	Cultural Landscape Report
	CMP	Collection Management Plan
	CSP	Collection Storage Plan
	DCP	Development Concept Plan
	EPD	Exhibit Plan and Design
	EIS	Environmental Impact Statement
	GMP	General Management Plan
	HFR	Historic Furnishings Report
	HRS	Historic Resource Study
	HSR	Historic Structure Report
	IPM	Integrated Pest Management
	LRIP	Long Range Interpretive Plan
	RMP	Resource Management Plan
	SOCS	Scope of Collection Statement
	VA	Value Analysis

Figure 12.1. NPS Acronyms Related to Servicewide Funding, Programs, and Planning for Museum Collections

Project Identification - PMIS 50283	
Project Title: Purchase Museum Storage Equipment (region-wide)	Project Total Cost: \$114,300.00
Park/Unit: Alaska Regional Office	Region: Alaska
States: AK	Congressional District: 01
Old Package Number:	Reference Number:
Project Type: Non-facility	Financial System Package Number: AKRO 050283
Contact Person: Betty Knight	Contact Phone: 907-257-2656
Project Status - PMIS 50283	
Date Created: 08/09/99	Review Status: Region-Reviewed on 11/30/2001
Date of Last Update: 05/29/03	Updated By: Stephanie Stephens (SStephens)
Project Narratives - PMIS 50283	
<p>Description</p> <p>This combines PMIS 50287 with this project (50283).</p> <p>Purchase and install museum cabinets, shelving units, media safes, fireproof filing cabinets and other specialized curatorial storage units throughout the region. Museum quality supplies, as well as the personnel to perform the upgrade are included in these projects.</p> <p>This will be an annually recurring account of up to \$63,000 through 2005.</p>	
<p>Justifications</p> <p>Alaska parks' collections are experiencing major growth, improvement of storage facilities, decompression of objects with improvements of storage conditions. Concurrently management is recognizing the wealth of unique cultural and natural history collections we manage. As the storage facilities are improved and expanded, at last there is room for more of the specialized equipment required. Additionally, we have been assessing archival resource and anticipate major expansion in that area as well as collections resulting from a resource initiative to inventory and monitor paleontological resources.</p>	
<p>Measurable Results</p> <p>Collection storage equipment is available in sufficient quantity and condition to meet standards at 10 collection storage facilities. As a result, GPRA Goal 1b2D will show an increasing percentage of standards met on a regional basis.</p>	

Figure 12.2 Sample PMIS Project Statement

Project Activities, Assets, Emphasis Areas and GPRA Goals - PMIS 50283	
Activities <ul style="list-style-type: none"> Maintain or Treat Cultural Resources Resource Protection 	Assets <ul style="list-style-type: none"> Museum Object and Specimen
Emphasis Areas <ul style="list-style-type: none"> Cultural Resource Protection Museum Property Natural Resource Protection Seismic 	GPRA Goals and Percent Values <ul style="list-style-type: none"> Museum Collections (Servicewide), 0%
Project Prioritization Information - PMIS 50283	
Unit Priority: 7	Unit Priority Band: LOW
Project Funding Component - PMIS 50283A	
Funding Component Title: Purchase Museum Storage Equipment (region-wide)	Funding Component Request Amount: \$114,300.00
Funding Component ID: 50283A	Funding Component Type: Non-recurring , Deferred Status Confirmed
Funding Component Description:	
Initial Planned FY: 2000	Requested Funding FY: 2003
Review Status: Region-reviewed on 11/30/2001	Funded Amount: \$63,000.00
Date of Park Submission:	Submitted By:
Upper-level Review Status:	Fee-demo Submission Number:
Formulated FY: 2004	Funded FY: 2003
Formulated Program: Other Program	Funded PWE Accounts: 9791-0304-UOC, 9865-0311-UOC, 9922-0302-UOC
Formulated Funding Source: Museum Collections Preservation and Protection	Funded Funding Source: Museum Collections Preservation and Protection
Component Cost Estimates	
Estimated By: Ruth Poff - AKRO	Date of Estimate: 03/28/2001
Estimate Good Until: 09/30/2001	Class of Estimate: A

Figure 12.2 Sample PMIS Project Statement (continued)

Item	Description	Qty	Unit	Unit Cost	Item Cost
supplies	[ITEM DESCRIPTION]	1	Lump	\$35,300.00	\$35,300.00
museum quality supplies	Yearly need for supplies within region.	1	Lump	\$7,000.00	\$7,000.00
Museum quality supplies	Yearly need for supplies within region.	1	Lump	\$7,000.00	\$7,000.00
museum quality supplies	Yearly need for museum supplies for repositories in region.	1	Lump	\$7,000.00	\$7,000.00
Storage upgrades throughout region in FY03	Correct deficiencies identified in the Automated Checklist at ARCC, KEFJ, WRST, WEAR and KATM.	1	Lump	\$58,000.00	\$58,000.00
Component Funding Request					\$114,300.00
Eligible Funding Sources and Funding Priorities					
Funding Source	Unit Priority at Formulation	Regional Priority	National Priority	Year Unit-Prioritized	
CRPP - Cultural Resources Preservation Program Base	7			2003	
Museum Collections Preservation and Protection	7	1		2003	
NRPP - Natural Resource Management	7			2003	
Component Start Date: 10/01/2003		Component Completion Date:			
Completion Status: Project Started		Accomplishment Reported By: Stephanie Stephens (Sstephens)			

Figure 12.2 Sample PMIS Project Statement (continued)

**Operations Formulation System
Request Detail Sheet**

Contact: Susan Hurst

Unit/Office: Golden Gate National Recreation Area **Region/Directorate:** Pacific West

Title of Funding Request: Manage Cultural Resources and Museum Collections

Total \$ Requested: 500,000	Recent Budget: FY 2003 - \$13,882,000	Last Operational Increase: FY 2002 - \$750,000
------------------------------------	--	--

Total FTE Requested: 7	Recent FTE: FY 2002 - 210	Request Type: Park Base
-------------------------------	----------------------------------	--------------------------------

OFS Number: 7356A	Date Created: 05/01/1999
--------------------------	---------------------------------

Servicewide Initiative:

Park Priority: 21.0	Date Last Modified: 02/18/2003	Budget Driver(s): 100% Threats to Resources
----------------------------	---------------------------------------	--

Regional Priority: 416.0	Earliest Year of Funding: 2003	Status: WASO Locked Approved By Region 03/18/2003
---------------------------------	---------------------------------------	---

Funding Component	PWE	FTE	Pers.	Other	Total	Recur.	Priority	GPRA Goal/Results
Provide Historical Architecture Services	CZS	1.0	85,000	3,000	88,000	Yes	1.0	1a5 / 50
Research-Historical Significance	CZH	1.0	85,000	3,000	88,000	Yes	2.0	1a5 / 50
Manage Cultural Landscapes	CZL	1.0	85,000	3,000	88,000	Yes	3.0	1a7 / 3
Manage Museum Collection	CZC	3.0	185,000	9,000	194,000	Yes	4.0	1a6 / 57
Provide Clerical Support	CZS	1.0	40,000	2,000	42,000	Yes	5.0	1a5 / 50

Figure 12. 3. Sample OFS Statement

GPRA Goal	Measurable Results	Performance Measure
Ia5	50	Each structure
Ia5	50	Each structure
Ia5	50	Each structure
Ia6	57	Each applicable standard
Ia7	3	Each landscape

Concise Description and Justification:

Golden Gate contains a nationally significant collection of cultural resources including over 1,250 historic structures, 7 cultural landscapes, 4 National Historic Landmark Districts and 6 National Register Districts. Professional expertise is required to manage all aspects of these resources including providing technical direction to maintenance and park partners to guide the repair and rehabilitations of structures and maintenance of cultural landscapes, managing A/E projects and processing compliance actions. In addition, Golden Gate's museum and archival collection of over 4.9 million items, including historic, archival, archeological and biological objects and specimens is the second largest such collection in the NPS. Insufficient resources exist to properly manage and care for this large, significant collection. Funds would provide for an enhanced level of professional management and protection of these irreplaceable cultural resources.

Supporting Information: None

Figure 12. 3. Sample OFS Statement (continued)

Chapter 13: Museum Housekeeping

	<u>Page</u>
A. Overview	13:1
What information will I find in this chapter?	13:1
What is a Museum Housekeeping Plan?	13:1
Why is museum housekeeping important?	13:2
Who is responsible for museum housekeeping?	13:3
What is museum housekeeping?	13:3
What is the goal of museum housekeeping?	13:4
What is the goal of cleaning?	13:5
How does museum housekeeping differ from housekeeping at home?	13:5
How often should I clean?	13:6
How do I find out the correct techniques for cleaning objects?	13:6
Where can I get training to learn more about housekeeping?	13:6
B. The Museum Housekeeping Plan	13:7
What are the components of a Museum Housekeeping Plan?	13:7
How do I prepare the title page?	13:7
How do I write the narrative section?	13:7
What are reference file sheets?	13:8
How do I complete the reference file sheet for environmental concerns?	13:8
How do I complete the reference file sheet for equipment or supplies used to monitor and control the environment?	13:8
What are housekeeping plan task sheets?	13:9
How do I prepare a task sheet?	13:10
What is a housekeeping schedule?	13:11
How do I prepare a housekeeping schedule?	13:12
Will ANCS+ help me develop my Museum Housekeeping Plan?	13:12
C. Selected Bibliography	13:13
D. List of Figures	13:15

CHAPTER 13: MUSEUM HOUSEKEEPING

A. Overview

1. *What information will I find in this chapter?*

Information in this chapter will help you to:

- understand the importance of museum housekeeping
- identify the elements of museum housekeeping
- write a Museum Housekeeping Plan
- find additional sources of information

The chapter includes sample formats for a Museum Housekeeping Plan. This format is not required. You can contact your Support Office curator for other sample housekeeping plans that parks have used.

This chapter will not tell you how to clean objects. That specific information is available from a variety of other sources listed in the references. You can also contact your Support Office curator for help.

2. *What is a Museum Housekeeping Plan?*

In the National Park Service, a written housekeeping plan is required for every space that houses museum collections, such as storage spaces, furnished rooms in a historic structure, indoor and outdoor exhibit spaces, curatorial offices, and work and reference spaces. See Cultural Resource Management Guideline (formerly NPS-28), 1997, Chapter 9, D.2.a, Preventive Conservation. Museum objects and historic spaces are cleaned in a different way than modern buildings and equipment that may house museum objects.

A staff curator, collateral duty curator, or contractor who has expertise in the preventive care of museum objects should write the housekeeping plan. The production of the plan should include all staff who will have housekeeping responsibilities. If the plan is written by someone other than the curator, the plan should be reviewed and recommended by the curator before approval by the superintendent. You can use the sample format presented here or contact your Support Office curator for other formats that have been used successfully in parks.

The Museum Housekeeping Plan sets up a schedule for preventive treatments. It serves as a reminder of what needs to be done and, generally, how often it needs to be done. The Museum Housekeeping Plan:

- considers the nature and condition of museum collections
- identifies the location of museum collections
- identifies both routine housekeeping tasks and special housekeeping projects
- identifies equipment, materials, and techniques for carrying out housekeeping tasks

- identifies staff persons responsible for carrying out housekeeping tasks
- establishes a schedule for completing the tasks
- records completed tasks

An approved Museum Housekeeping Plan provides a framework for consistent care of museum objects. It institutionalizes a preventive conservation program. The preservation of the museum collection depends on adherence to the plan by the entire park staff over time. No single employee is responsible for care of the objects. The plan is based on the idea that preventive conservation is an ongoing process—not a product.

A well-written Museum Housekeeping Plan is the basis for your park's preventive conservation program.

3. *Why is museum housekeeping important?*

Preventive conservation, the *primary goal of housekeeping*, aims to prevent damage to museum collections. See Chapter 3, Preservation: Getting Started, for a discussion of preventive conservation. Housekeeping is essential to your preventive conservation program.

From the moment an object is created, it begins to deteriorate as a result of its interaction with the environment. At certain points in its life, a museum object may require the knowledge and skills of a conservator to stabilize its condition. You can minimize the need for conservation treatment by implementing a museum housekeeping program in all spaces that house museum objects, such as:

- exhibit spaces
- historic furnished rooms
- storage spaces
- curatorial offices
- research services spaces
- other work spaces

Each space will require a slightly different approach to cleaning that takes into account how objects are stored and used. For example, exhibit spaces with closed cases may require only annual dusting of objects. Historic furnished rooms, with objects on display in the open air, will require daily or biweekly cleaning.

Preventive Conservation	
Curator/Collateral Duty Curator	Other Park Staff
<ul style="list-style-type: none"> • Monitors and assesses the condition of objects • Monitors and evaluates the museum environment • Practices proper methods and techniques for storing, exhibiting, handling, packing and shipping of objects • Develops and carries out an ongoing housekeeping program for collection spaces • Prepares an emergency management plan for the museum collection • Prepares an Integrated Pest Management program for the museum collection • Coordinates park's Museum Housekeeping Plan 	<ul style="list-style-type: none"> • Provide guidance, in their area of expertise, on effective means of achieving preservation standards for museum objects • Alert curator to impending activities that may impact museum collections but are not addressed in the Museum Housekeeping Plan • Prepare parkwide emergency management plan • Prepare the parkwide Integrated Pest Management plan • Assist in development and annual review of the Museum Housekeeping Plan • Implement the actions of the Museum Housekeeping Plan for which they are responsible

Figure 13.1. Curator and Other Park Staff Roles in Preserving Museum Collections

4. *Who is responsible for museum housekeeping?*

The park superintendent delegates responsibility for the day-to-day management of museum objects to a permanent full-time, part-time, or collateral duty curator. Non-curatorial staff may also play significant roles in preserving museum objects. For example, keeping air filters clean in a heating, ventilation, air conditioning (HVAC) unit is a preventive conservation action that may be carried out by non-curatorial staff, but that task has significant impact on the long-term preservation of museum objects. This shared responsibility requires close cooperation and open communication between the curatorial and maintenance staff. Although the superintendent may delegate duties, housekeeping must be a primary concern of site management; sound housekeeping practices are significant for the visitor experience and visitor safety, as well as for resource preservation.

Good museum housekeeping needs the contributions of all park staff including maintenance personnel, interpreters, historians, architects, and other cultural resources staff. Individual parks will divide these responsibilities differently. Curatorial staff must keep close watch over the effects of cleaning, informing maintenance when methods or frequency seem harmful. Maintenance and other staff have a reciprocal obligation to consult the curator and take advice or work out acceptable alternatives. See Figure 13.1 for shared roles in preserving museum collections.

5. *What is museum housekeeping?*

In the context of museum collections management, the term "housekeeping" is defined as all of the ongoing actions (tasks) to preserve museum objects, archives, and museum records. Housekeeping is planning and monitoring, as much as it is hands-on collections care. Housekeeping requires *looking* as much as *doing*. Knowing when *not* to clean is as important as knowing when and how to clean. Housekeeping involves such tasks as:

- building and site care
- monitoring the effectiveness of environmental controls
- monitoring and recording light, temperature, and relative humidity levels
- monitoring for pests
- cleaning or replacing filters in air handling units
- monitoring the condition of museum objects
- dusting
- vacuuming
- applying protective waxes

Housekeeping is a major, and very challenging, part of a collections management program.

- It will greatly increase or greatly decrease the life of museum objects.
- It requires direct contact with museum objects.
- It is time consuming.

6. *What is the goal of museum housekeeping?*

Good museum housekeeping minimizes deterioration of objects by focusing on preventive care. Housekeeping relies on blocking the agents that deteriorate artifacts, such as pests, pollutants, and UV light, and monitoring to be sure that preventive actions are working. It enables you to inspect your collection on a routine basis so that deterioration can be detected early. Only when preventive techniques have failed, will cleaning need to be carried out.

If you approach housekeeping with this preventive approach in mind, instead of as a series of hands-on tasks, you will minimize damage to artifacts. In the long run you will also save a lot of time.

For example:

You can place floor mats at the entrance into historic houses where objects are exhibited, limiting the amount of dirt brought into the space that can be kicked up as dust. If you use a HEPA (high efficiency particulate air) filter vacuum when you clean, you minimize the amount of dust blown out into the air. Making sure doors and windows are tight limits the amount of dust blown in from outside. If all these preventive measures are taken, then the amount of dust that collects on objects and the amount of time and energy needed for cleaning will be minimized. With less cleaning and handling the chance that an object will be damaged is curbed.

You must work with and educate other park staff to improve preventive care and limit the amount of cleaning you must do. Effective care requires the cooperation of all staff members that work with and around collections.

7. *What is the goal of cleaning?*

The goal of cleaning is to preserve museum collections. Most of the traditional housekeeping tasks, such as dusting and vacuuming, are tasks also done at home. As a museum professional, you also dust and vacuum in museum exhibits, storage rooms, and furnished structures.

However, you should keep in mind that the significant difference between housekeeping at home and housekeeping in museums is the goal of preservation. Approach cleaning spaces that house museum collections from a different point of view. Consider:

- the nature and condition of objects
- cleaning materials and methods appropriate to object preservation
- signs of object deterioration
- interpretive effects in exhibits and furnished historic rooms

8. *How does museum housekeeping differ from housekeeping at home?*

Think about and understand why you are undertaking a certain housekeeping task. At home, the primary concern is usually aesthetics. You may want home furnishings and fixtures to look clean and shiny with the least amount of effort, so scrubbing and polishing may be done in haste. At a museum, these tasks are undertaken primarily to preserve collections. Cleaning must be careful, gentle, and thorough. If you simply clean for appearance, as you may do at home, then damage to collections will inevitably occur.

Express your museum housekeeping attitude through careful, thoughtful, and gentle actions.

“Clean” in museums means that enough collected dirt has been removed so that deterioration will not take place. It does not mean spotless or “white glove” or “squeaky” clean. Evaluate the situation each time cleaning is done and decide first, if it is necessary and second, how far you must clean. Careful museum housekeeping requires using the correct supplies and equipment with proper techniques for the preservation of a museum collection. For example:

- When *dusting*, apply minimum pressure, move carefully, and frequently change to a clean dust cloth.
- When *vacuuming*, don't allow the vacuum cleaner, including cords and attachments other than the brush, to come into contact with museum objects.

See the references listed at the end of this chapter for more explanations of cleaning techniques and supplies for all types of materials.

Understand what each housekeeping task will accomplish. What are you doing and why you are doing it? A neat and clean museum will be the result of housekeeping, but it is not the only goal. Think of museum housekeeping as preventive conservation. You and your staff are trying to prevent damage to museum objects before it occurs.

Museum housekeeping requires an objective approach. Before beginning your daily tasks, ask yourself, “Am I prolonging the life of the object?” You need to *think preservation*.

9. *How often should I clean?*

There is no typical time period for cleaning. You might only have to vacuum a secure storage area that you monitor for pests once a month, or twice a year. However, you may need to vacuum the floor once a day in a poorly sealed log cabin that gets many visitors. Unnecessary and frequent cleaning can damage objects and may lead to their consumptive use.

To decide on how often to clean, think critically. Take into account how dirt, pests and other contaminants get into a space. Think about how many people go through an area. Walk through and carefully look at the space to see where dirt collects and how quickly.

A park can decide if cleaning should be done during operating hours when the public can see you care for the collections, or at times when spaces are closed to the public. Explaining housekeeping tasks can be a part of your resource preservation message.

10. *How do I find out the correct techniques for cleaning objects?*

There are a variety of information sources available that give overviews of housekeeping and describe specific techniques and materials. You should obtain books and videos listed in the bibliography and keep them available as references.

Watch the following NPS sources for new information and techniques:

- NPS *Conserve O Gram (COG)* series
- cc:Mail NPS *Museum Management Newsletter*
- NPS *Museum Handbook*, Part I, Curatorial Care Appendices

11. *Where can I get training to learn more about housekeeping?*

There are a variety of places you can find more information about housekeeping.

- The NPS Curatorial Bulletin Board lists advertisements for courses that are taught at various institutions around the country.
- A variety of written references and videos are available. See the bibliography for specific references.
- Contact your Support Office curator for more information.

B. The Museum Housekeeping Plan

1. *What are the components of a Museum Housekeeping Plan?*

There are a variety of ways to format a MHP. The format described here is one example. For other examples contact your Support Office curator.

The Museum Housekeeping Plan illustrated here includes:

- Title Page
- Narrative Section
- Reference File Sheets
- Task Sheets
- Schedules

2. *How do I prepare the title page?*

The title page includes the:

- title
- full name of park
- review and approval signature lines

A table of contents is helpful for people using the plan. You may add additional sign-off lines and circulate the plan through each appropriate division. This practice documents in writing each division's commitment to implement its part of the plan. The superintendent provides final approval. Figure 13.2 illustrates the proper format for the Title Page.

3. *How do I write the narrative section?*

State the purpose of the Museum Housekeeping Plan. Sample language for this section follows. Append additional park-specific language as needed.

Preventive conservation is the ongoing activity of non-invasive actions taken to prevent damage to and minimize deterioration of museum objects. Housekeeping, executed faithfully and with professional judgment, is a crucial component of preventive conservation. The park has developed this Museum Housekeeping Plan to ensure consistent, long-term care of its museum collections. The plan is the product of a cooperative effort between all involved divisions and has the support of the superintendent.

The narrative outlines a cohesive program of care that the plan documents. You can include information on:

- the locations for museum housekeeping
- the tasks to be performed
- the appropriate techniques for accomplishing the tasks
- the frequency of each task
- the title and name of person(s) responsible for performing the tasks
- the appropriate supplies and equipment

4. *What are reference file sheets?*

Reference file sheets can help you collect all the information dispersed in a variety of documents on equipment and supplies and environmental concerns. Using the reference file sheets you collect all this information once, instead of having to find it repeatedly. Documents that contain

information collected in reference file sheets include the Collection Management Plan, (CMP), Collection Condition Survey (CCS), historic furnishings reports, equipment handbooks, and environmental monitoring records.

Complete reference file sheets for:

- environmental concerns
- equipment to monitor and control the environment
- supplies to monitor and control the environment

Reference file sheets provide data necessary to complete the task sheets.

5. *How do I complete the reference file sheet for environmental concerns?*

The reference file sheet for environmental concerns identifies ongoing issues for maintaining environmental standards, and lists tasks necessary to maintain or work toward those standards for each location containing museum objects.

See Figure 13.3 for a suggested format for the reference file sheet.

- Under "Location," enter the park acronym and common name of structure.
- Summarize for each space the existing environmental factors (temperature, relative humidity, light, pest infestation, and dust/pollution).
- List sources from which data were derived.
- List all tasks relevant to the preservation of the museum objects.

6. *How do I complete the reference file sheet for equipment or supplies used to monitor and control the environment?*

Prepare a reference file sheet for equipment and supplies used to monitor and control the environment. Describe the equipment, give model numbers, and location of manuals and supplies. Also list tasks necessary to maintain the equipment.

See Figure 13.4 for a suggested format for a reference file sheet for equipment and supplies used to monitor or control the environment.

- Under "Location," enter the park acronym and the common name of the structure/space.
- List type, size, quantity, and brand of portable equipment (such as vacuum cleaners, humidifiers, dehumidifiers, hygrothermographs, dataloggers).
- State the location of the equipment in the space. You may want to attach a floor plan of the space that indicates the location.
- State the location of operational and maintenance manuals, warranties and additional supplies.

- List all sources for the information on the reference file sheet.
- List all tasks relevant to maintaining the equipment or supply described. Include tasks such as changing vacuum filters and reconditioning silica gel.

Record the quantity of supplies used throughout the year. Keep extra vacuum cleaner bags and cleaning supplies in stock. Track and quantify the expenditure of supplies to ensure that you have sufficient quantities.

Mark or label supplies and equipment used for preventive conservation. Use them only for that purpose. Limiting use prevents the unintentional introduction of dirt and residues into spaces that house museum collections.

7. *What are housekeeping plan task sheets?*

Complete task sheets for all tasks listed on reference file sheets (see no. 4 above). When preparing the sheets, you need to involve discipline and job specialists, as appropriate, from all divisions. Working with other staff members to develop the tasks will identify all the aspects of care that must be addressed. A cooperative approach to preventive care will begin to develop when you work with all staff members involved in caring for collections.

Task sheets and schedules provide a mechanism for tracking the costs of preserving and protecting museum objects. Task sheets can also be used to support the need for additional staff or funding to carry out necessary housekeeping tasks. The task sheets:

- provide detailed procedures to be followed such as specialized handling techniques
- identify appropriate equipment and supplies for each task
- determine the frequency of performance, which must be critically evaluated each time the task is performed

The objectives of the task sheets and schedules are to ensure that no task is overlooked, and to avoid duplication of effort through:

- efficient dove-tailing of divisional responsibilities
- judicious use of limited resources

Review and revise the task sheets at least once a year and whenever other park planning or operational documents (such as the Emergency Operations Plan) are updated.

8. *How do I prepare a task sheet?*

See Figures 13.5-8 for samples of task sheets. You may use this suggested format or design your own reports. Adjust time and cost estimates based on staff experience.

See Section E for a list of MH-I, Curatorial Care Appendices that provide guidance on preventive care and cleaning techniques for specific material and object types.

For each task sheet:

- List the location.

Include the park acronym and common name of structure.

- Identify the task.

Option 1: For each task, object, or piece of equipment, use one task sheet. Vacuuming in a historic house could have one task sheet. If one table has an unstable veneer and requires special handling techniques, it should have its own task sheet. Include a task sheet to maintain the equipment. For example, mops and dust cloths must be washed, dried, and put away carefully.

Option 2: Use one task sheet for several identical objects. For example, all the upholstered furniture may be cared for using the same procedures and techniques.

- State how often a task should be performed (frequency). Be sure to include statements on how to evaluate whether the task needs to be performed. Your observations and experience will influence the frequency for each task. Each time the task is performed, it should be reevaluated. The frequency may also be affected by the interpretive goal of an exhibit or furnished historic structure.

- Describe procedures.

Describe how the task will be accomplished safely, appropriately, and effectively. **Consult conservators and discipline specialists and refer to professional publications to confirm that procedures are appropriate and current.**

- State cautions.

Identify any physical hazards associated with the task (such as heavy lifting). When chemicals (even detergents) are used for cleaning, attach a copy of the applicable Material Safety Data Sheet (MSDS) to the task sheet, or state where it may be obtained elsewhere in the park.

- Provide current staff assignment(s). List the name and title of the staff member currently responsible for completing the task.

- Identify skills and training needed.

Describe the skills or training required to perform the task. Staff should practice only those preventive conservation techniques and procedures for which they are trained. For example, only staff who have been trained by a conservator may undertake treatments such as removing or re-applying wax or lacquers. See Chapter 3 for a discussion of the roles of the curator and conservator.

The hands-on care of collections, including activities that occur near museum objects (such as vacuuming), requires special care and aptitude. If you are involved in such activities, you need to demonstrate sensitivity for the objects as well as the physical coordination needed to handle objects safely. Training and re-training are important elements in developing and improving these skills, and should be addressed in a separate task sheet.

- Identify supplies and equipment needed for each task.

Provide a common descriptive name that distinguishes between similar pieces of equipment (such as a double filter vacuum or wet-vac). List identification numbers if necessary. See *NPS Tools of the Trade* for information on obtaining museum supplies and equipment.

- State sources used to develop each task sheet. Include published works and personal communications.
- Provide information on who prepared tasks sheets and when.

9. *What is a housekeeping schedule?*

Museum housekeeping schedules are an important part of the plan. The schedules are guides that:

- remind you when to do tasks (Season and visitation variations may affect the frequency of tasks.)
- chart the progress and provide a means of tracking the status of the housekeeping program
- prevent tasks from being crowded out or forgotten

10. *How do I prepare a housekeeping schedule?*

Combine information on specific tasks and procedures (identified on task sheets) into a schedule for each responsible staff member.

- Allot each task adequate time at the proper intervals. (Refer to frequencies compiled in the task sheets.)
- Organize tasks on the schedule as follows:
 - daily
 - weekly
 - monthly
 - quarterly
 - semi-annually
 - cyclically (less or more often than annually)
 - as needed

- List all tasks concisely.
- Use a chart to format your schedule.
- File all completed charts for future reference.

Provide a space for initials or check-off and dates to document each time a task on the schedule is carried out. You may wish to add other useful information such as cost for the task and account numbers to be charged.

See Figures 13.9-12 for sample formats. You can use these formats as is, or adapt them to your particular park needs as you write your housekeeping plan.

11. *Will ANCS+ help me develop my Museum Housekeeping Plan?*

The task sheets and schedules described in this chapter can be generated using the Maintenance associated module and Maintenance supplemental record in ANCS+. You can find information on using the Maintenance associated module in Chapter 4 and the Maintenance supplemental record in Chapter 3 in the ANCS+ User Manual (1998).

C. Selected Bibliography

Applebaum, Barbara. *Guide to Environmental Protection of Collections*. Madison, Conn.: Sound View Press, 1991.

Butcher-Youngmans, Sherry. *Historic House Museums: A Practical Handbook for their Care, Preservation, and Management*. New York: Oxford University Press, 1993.

Canadian Conservation Institute. *CCI-ICC Notes*. Ottawa, Canada: Canadian Conservation Institute.

Cassar, May. *Environmental Management: Guidelines for Museums and Galleries*. London: Routledge, 1994.

Centre de conservation du Québec, Canadian Conservation Institute and Université du Québec à Montréal. *Preventive Conservation in Museums, Video Handbook*. Ottawa, Canada: Canadian Conservation Institute.

_____. *Preventive Conservation in Museums*, series of 19 videocassettes. Available from Université du Québec à Montréal, Audiovisual Department, Production Services, Box 8888, Station Centre-Ville, Montréal, QC H3C 3P8, Tel. (514) 987-6195.

Chambers, J. Henry. *Cyclical Maintenance for Historic Buildings*. Washington, D.C.: National Park Service, Interagency Historic Architectural Services Program, Office of Archeology and Historic Preservation, 1976.

Fred Woods Productions. *Housekeeping for Historic Sites*. National Park Service; New York State Office of Parks, Recreation and Historic Preservation; and Society for the Preservation of New England Antiquities, 1996, videocassette. Available from Society for the Preservation of New England Antiquities Merchandise Department, 141 Cambridge Street, Boston, Mass. 02114; Phone: (617) 227-3956, Fax: (617) 227-9204.

National Park Service. *Museum Handbook*, Part I, Museum Collections. Washington, D.C.: National Park Service, Museum Management Program, 1990.

Appendix I: "Curatorial Care of Archeological Objects"

Appendix J: "Curatorial Care of Paper Objects"

Appendix K: "Curatorial Care of Textile Objects"

Appendix L: "Curatorial Care of Paintings"

Appendix M: "Curatorial Care of Cellulose Nitrate Negatives"

Appendix N: "Curatorial Care of Wooden Objects"

Appendix O: "Curatorial Care of Metal Objects"

Appendix P: "Curatorial Care of Ceramic, Glass, and Stone Objects"

Appendix R: "Curatorial Care of Photographic Collections" (1996)

Appendix S: "Curatorial Care of Objects Made from Leather and Skin Products" (1996)

_____. *Conserve O Gram* series. Washington, D.C.: National Park Service, Museum Management Program, 1993.

Sandwith, Hermione, and Sheila Stainton. *The National Trust Manual of Housekeeping* (Second Edition). London: Penguin Book, 1988.

Schultz, Arthur W., ed. *Caring for your Collections*. New York: National Institute for the Conservation of Cultural Property, Harry N. Abrams, 1992.

Simonson, Kaye Ellen, compiler. *Maintaining Historic Buildings: An Annotated Bibliography*. Washington, D.C.: U.S. Department of the Interior, National Park Service, Preservation Assistance Division, 1990.

D. List of Figures

Figures 2-12 illustrate sample formats for writing your Museum Housekeeping Plan.

- 13.1 Curator and Other Park Staff Roles in Preserving Museum Collections
- 13.2 Sample MHP Title Page
- 13.3 Sample MHP Reference File Sheet: Environmental Concerns
- 13.4 Sample MHP Reference File Sheet: Equipment/Supplies Used to Control the Environment
- 13.5 Sample MHP Task Sheet: Dusting
- 13.6 Sample MHP Task Sheet: Pest Monitoring
- 13.7 Sample MHP Task Sheet: Review Housekeeping Plan
- 13.8 Sample MHP Task Sheet: Special Uses
- 13.9 Sample MHP Tracking Schedule: Daily
- 13.10. Sample MHP Tracking Schedule: Weekly
- 13.11 Sample MHP Tracking Schedule: Quarterly
- 13.12 Sample MHP 5-Day Schedule

You can use these Sample plans as is or adapt them when preparing your own Museum Housekeeping Plan. MHP Task Sheets, and MHP Daily, Weekly, and Quarterly Schedules can be produced using the Automated National Catalog System (ANCS+). Using ANCS+ to generate your plans will help you track maintenance treatments on individual objects.

DEPARTMENT OF THE INTERIOR
NATIONAL PARK SERVICE
PARK NAME
STRUCTURE NAME
MUSEUM HOUSEKEEPING PLAN

Prepared by:	_____	_____
	Title	Date
Recommended by:	_____	_____
	Park Curator	Date
Approved by:	_____	_____
	Superintendent	Date

Figure 13.2. Sample MHP Title Page

**NATIONAL PARK SERVICE
MHP REFERENCE FILE SHEET
ENVIRONMENTAL CONCERNS**

Location: CHDO, Visitor Center, Exhibit Space

Temperature: Gradual fluctuations occur seasonally within a 5° - 10°C range (60°-70°F). Maintenance staff makes adjustments to climate control equipment only after consultation with curatorial staff.

Relative Humidity: Relative humidity is poorly controlled. Front entrance doors provide immediate access to the outdoors, allowing air and humidity to flood the exhibit area whenever visitors enter. Microclimates in exhibit cases must be maintained to compensate for unacceptable levels of RH. Construction of a separate entrance alcove is planned for FY1999 (refer to Resources Management Plan Project Statement #14 and Development/Study Package Proposal Form 10-238 #93-1).

Light: Applied light tint solar control film to exterior windows in June 1990. Filters remove 96% of UV, and 30-40% of visible light.

Pest Infestations: With the exception of an annual influx of yellow jackets, no insect infestations have been recorded to date. Park curatorial staff arranges for removal of these insects from collection areas.

Dust/pollution: Dust levels are relatively low because concrete sidewalks provide access to the structure. Interpreters bring walking tours from the historic trace road, which is dirt, into the Visitor Center through the side door and across a dust mat.

Source: Environmental monitoring records, curator's office, Cabinet 4, Drawer 3.
CHDO IPM Plan, 1991, p. 44.

Tasks:

- Monitor temperature and relative humidity. Weekly.
- Monitor sticky traps for pests. Weekly.
- Monitor silica gel tiles in cases, and recondition regularly. Monthly.
- Monitor condition of objects, especially those located nearest the entrance. Weekly.
- Monitor progress of Development/Study Package Proposal (Form 10-238) #93-1. Quarterly.
- Monitor condition of UV filters and replace when needed. Quarterly.
- Inspect case seals. Annually.
- Inform interpretive staff of rationale and procedures for following established tour routes at seasonal and permanent staff training sessions. Annually in May.

Prepared by: Nathan Santiago

Title: Museum Curator

Date: June 17, 1992

Figure 13.3. Sample MHP Reference File Sheet: Environmental Concerns

*Information provided for specific tasks on these samples should not be regarded as standards.
See Section A above for a discussion of the decision-making process that goes into developing these sheets.*

**NATIONAL PARK SERVICE
MHP REFERENCE FILE SHEET
EQUIPMENT/SUPPLIES USED TO CONTROL THE ENVIRONMENT**

Location: CHDO, Visitor Center, Storage Space

Type of Equipment/Supplies: HEPA vacuum

Size: Medium, 16" x 12" x 12"

Quantity: 1

Brand: Nilfisk GS80I

Location in Space: See attached floor plan.

Location of Manuals: Operational and repair manual is in Curator's Office, File Cabinet 1, Drawer 2, File "Equipment." Note: The curator's manual is the only copy on site.

Location of Supplies: Replacement bags and filters are in Storage Cabinet 4, Shelf B in the curatorial supplies storage area. Order one year's supply of bags (12) and one HEPA exhaust filter annually in January.

Sources: Nilfisk product information. Duplicates available from Nilfisk (610) 647-6420.

Tasks:

- Purchase replacement bags and filters. January.
- Change bags. Monthly, and more often if necessary.
- Change HEPA filter. January.

Prepared by: Betty Ann Kinitz

Title: Museum Tech

Date: April 1, 1988

Figure 13.4. Sample MHP Reference File Sheet: Equipment/Supplies Used to Control the Environment

You may create a separate sheet for each piece of equipment or combine all equipment on one reference sheet if appropriate.

**NATIONAL PARK SERVICE
MHP TASK SHEET
DUSTING**

Location: CHDO, LCS#101, Room 101, Wall Cabinet (Chris Doe Homeplace, Front Parlor)

Task: Clean wall cabinet, dust objects in cabinet

Frequency: Monthly. Before dusting, carefully inspect objects and cupboard to decide if cleaning is necessary.

Procedure:

- Prepare space on table to receive objects.
- Remove objects from cupboard.
- Check pest trap on lower shelf. Replace with new trap.
- Dust wooden cupboard with soft dust cloth. Give special attention to molding, using a soft artist's brush to dust. Dust ceramics and glass with brush.
- Replace items using sketch from HFR (attached).
- Incorporate pest trap findings into IPM records. (Forward to Curator.)
- Wash dust clothes and brushes in non-ionic soap at first sign of darkening.

Cautions:

- Lid on stein is not attached; handle top and base separately.**
- Use surgical gloves when handling china.

Currently Assigned to: Adam Karlson, Museum Technician

Special Skills/Training: Watch curatorial handling video.

Supplies/Equipment:

- Soft artist's brush
- Soft dust cloth
- Pest trap
- Surgical gloves

Sources:

- Chris Doe House, Historic Furnishings Report, Harpers Ferry Center, 1997.
- Museum Handbook, Part I, Appendix P, "Curatorial Care of Ceramic, Glass, and Stone Objects"

Prepared by: Nathan Santiago

Title: Museum Curator

Date: July 16, 1992

Figure 13.5. Sample MHP Task Sheet: Dusting

*You can prepare one sheet for all dusting tasks or divide them as needed for your park.
The Maintenance associated module in ANCS+ can help you generate these task sheets.*

**NATIONAL PARK SERVICE
MHP TASK SHEET
PEST MONITORING**

Location: CHDO, Visitor Center, Exhibit Space

Task: Monitor for pests

Frequency: Weekly

- Procedure:**
- Prepare new pest traps; write the location and number on each trap. Where necessary for clarity, draw a rough sketch of the room or wall.
 - Collect traps from previous week. Place carefully inside plastic bags and seal.
 - Put new traps into position.
 - In work area (outside of storage room), count numbers of each specimen type and record data on data sheets or enter into database.
 - If action thresholds have been exceeded, take appropriate action. Report action to PCM Coordinator and park IPM Coordinator (Marc Johnson, Resources Management Specialist). Action thresholds listed in CHDO IPM Plan.
 - Incorporate new specimens into the IPM reference collection.
 - Initial and date schedule.

Cautions:

- Mouse traps were placed in the southwest corner of the Visitor Center on May 31. If a mouse has been caught, discard trap and mouse, and replace trap, notify IPM Coordinator.

Currently Assigned to: Dr. Joachim Kapp, Volunteer

Special Skills/Training: Identify insects and rodents.

Supplies/Equipment:

- Pest traps
- Microscope
- Record sheets and/or database access

Sources: CHDO IPM Plan

Prepared by: Marc Johnson

Title: Resources Management Specialist

Date: June 3, 1991

Figure 13.6. Sample MHP Task Sheet: Pest Monitoring

The Maintenance associated module in ANCS+ can help you generate these task sheets.

**NATIONAL PARK SERVICE
MHP TASK SHEET
REVIEW HOUSEKEEPING PLAN**

Location: FOLA, Officer's Quarter #14

Task: Review Housekeeping Plan

Frequency: Annually (January)

- Procedure:**
- Assess currency of plan. If changes, based on observation and experience with plan, are needed to improve implementation, circulate the revised plan to appropriate reviewers on-site.
 - If necessary, revise to keep plan current with changes in technology and procedure. Make copies for formal review. Reviewers may include: Curator, Park Architect, Building and Utilities Foreman, Conservator, Volunteers involved in implementing the plan, Support Office Curator, Interpretive Staff.
 - Distribute plan for review. Allow a minimum of six weeks for review.
 - Incorporate comments as appropriate into plan.
 - Route for formal signature.
 - Distribute copies of revised plan.
 - Initial and date schedule.

Cautions: A memo reminding staff of impending review is recommended as a courtesy to staff.

Currently Assigned to: Team: Lenore O'Doul, IPM Coordinator and Nathan Santiago, Museum Curator

Special Skills/Training: Familiarity with museum objects and the structure and their respective requirements.

Supplies/Equipment: None

Sources: Housekeeping Plan for Officer's Quarters #14

Prepared by: Nathan Santiago

Title: Museum Curator

Date: October 19, 1992

Figure 13.7. Sample MHP Task Sheet: Review Housekeeping Plan
The Maintenance associated module in ANCS+ can help you generate these task sheets.

**NATIONAL PARK SERVICE
MHP TASK SHEET
SPECIAL USES**

Location: CHDO, LCS #101, Chris Doe Homeplace

Task: Plan evening tours of Homeplace, CHDO Birthday Weekend

Frequency: Annually in September-October

Procedure:

- Review interpretive plans. **Consumptive use of original furnishings as part of the tours is specifically prohibited (e.g., sitting on chairs or using tables as writing surfaces).** If reproductions are substituted, schedule staff and time to move furnishings and to restore rooms to their normal arrangement. No less than one month before event.
- Review security plan for event with Law Enforcement and Interpretive staff supervisors. Give special attention to opening and closing procedures. Two weeks before event.
- Consult Interpretive Supervisor. Schedule an adequate number of staff/VIPs to protect objects. No less than two people per floor. Curator and Museum Technician to be stationed at Homeplace during the event. Two pay periods before event.
- Review security plan with staff and volunteers assigned to homeplace tours no more than one week before event.
- Install VARDA motion detection units in each room. See attached sheet for locating units out of visitors' sight.
- Ensure special event supplies and equipment are in homeplace and operational.
- Clean-up.
- Conduct visual inventory each evening after tours.
- Implement weekly housekeeping procedures each day of event, as needed.

Cautions:

- Attendance at tours has averaged 1500 visitors per night.
- Use of lighted candles inside the building is specifically prohibited.**

Currently Assigned to: Lenore O'Doul, IPM Coordinator

Special Skills/Training:

- Familiarity with security plan.
- Training in park radio procedures.
- Training in crowd control/observation in special events.

Supplies/Equipment:

- 3 Flashlights, extra batteries.
- Park radio.
- 8 VARDA units.

Sources: Chris Doe NP Interpretive Prospectus, (revision in progress).

Prepared by: Nathan Santiago

Title: Museum Curator

Date: June 12, 1987

Figure 13.8. Sample MHP Task Sheet: Special Uses
The Maintenance associated module in ANCS+ can help you generate these task sheets.

CHRIS DOE HOMEPLACE
Location

FEBRUARY 1991
Month - Year

JOHN ENGLAND
Staff Name

Daily	1	2	3	4	5	6	7	8	9	10	11	12	13	14	15	16	17	18	19	20	21	22	23	24	25	26	27	28	29
Dust mop entrance	✓	✓	✓	✓	✓	✓	✓	✓	✓	✓																			
Clean ext. exhibit cases	✓	✓	✓	✓	✓	✓	✓	✓	✓	✓																			
Vacuum doormats	✓	✓	✓	✓	✓	✓	✓	✓	✓	✓																			
Clean restrooms	✓	✓	✓	✓	✓			✓	✓	✓																			
Remove trash/food	✓	✓	✓	✓	✓	✓	✓	✓	✓	✓																			

Comments: Restrooms flooded on the 6th and 7th.

Figure 13.9. Sample MHP Tracking Schedule: Daily
The Maintenance associated module in ANCS+ can help you generate schedules.

Weekly	1	2	3	4	5	6	7	8	9	10	11	12	13
Change hygrothermograph charts	✓	✓											
Check pest traps	✓	✓											
Dust objects in historic rooms	✓	✓											
Buff waxed floors	✓	✓											

Comments:

Figure 13.10. Sample MHP Tracking Schedule: Weekly
The Maintenance associated module in ANCS+ can help you generate schedules.

Quarterly	1997				1998				1999			
	1 st Qtr.	2nd Qtr.	3rd Qtr.	4th Qtr.	1st Qtr.	2nd Qtr.	3rd Qtr.	4 th Qtr.	1st Qtr.	2nd Qtr.	3rd Qtr.	4 th Qtr.
Vacuum silk sofa	✓											
Dust lamp shades	✓											
Measure visible light readings	✓											
Measure UV light readings	✓											
Vacuum beneath beds	✓											
Turn open book pages	✓											
Dust lighting fixtures	✓											

Comments:

Figure 13.11. Sample MHP Tracking Schedule: Quarterly
The Maintenance associated module in ANCS+ can help you generate schedules.

SUMMER

5-DAY SCHEDULE

MONDAY	TUESDAY	WEDNESDAY	THURSDAY	FRIDAY
V.C. EXHIBIT Clean floor Damp wipe door knobs Dust Pest check Clean glass on cases	Clean floor Vacuum all floors & baseboards Clean glass on cases Change hygrothermograph chart	Clean floor Damp wipe door knobs Clean glass on cases Clean window sills, ledges, tops of door	Clean floor Clean text & graphics Clean doormats Dust Clean glass on cases	Clean floor Vacuum flies Vacuum all floors & baseboards Damp wipe door knobs Clean glass
WORKSHOP Clean floor Damp wipe door knobs Clean glass on cases Record thermo-hygrometer	Clean floor Dust Pest check Clean glass on cases Record thermo-hygrometer	Clean floor Clean window sills, ledges, tops of door Damp wipe door knobs Clean glass Record thermo-hygrometer	Clean floor Clean text, graphics & railings Clean glass Record thermo-hygrometer	Clean floor Dust exhibit cases & furniture Clean glass Damp wipe door knobs Record thermo-hygrometer
STORAGE Inspection Pest Check	Change hygrothermograph charts			Sweep floors Straighten
HOMEPLACE Dust mop entrance Clean exterior exhibit cases Vacuum doormats Clean restrooms Remove trash/food	Change hygrothermograph charts Dust mop entrance Clean exhibit cases Vacuum doormats Clean restrooms Remove trash/food	Check pest traps Dust mop entrance Clean exhibit cases Vacuum doormats Clean restrooms Remove trash/food	Dust objects in historic rooms Dust mop entrance Clean exhibit cases Vacuum doormats Clean restrooms Remove trash/food	Buff waxed floors Dust mop entrance Clean exhibit cases Vacuum doormats Clean restrooms Remove trash/food

Figure 13.12. Sample MHP 5-Day Schedule

Appendix A: Mandates and Standards for NPS Museum Collections

	<u>Page</u>
A. Overview	A:1
B. Laws, Regulations, and Conventions – NPS Cultural Collections	A:1
Laws related to NPS cultural collections	A:1
Regulations related to NPS cultural collections	A:4
International conventions related to NPS cultural collections	A:5
Contacts for laws, regulations, and conventions – NPS cultural collections	A:6
C. Laws, Regulations, and Conventions – NPS Natural History Collections	A:6
Laws related to NPS natural history collections	A:6
Regulations related to NPS natural history collections	A:8
International conventions related to NPS natural history collections	A:8
Contacts for laws, regulations, and conventions – NPS natural history collections	A:9
D. Policies and Standards	A:9
Governmentwide and departmental policies and standards related to NPS museum collections	A:9
NPS management policies for museum collections	A:10
NPS Director’s Orders and guidance for museum collections	A:14
E. List of Figures	A:16

APPENDIX A: MANDATES AND STANDARDS FOR NPS MUSEUM COLLECTIONS MANAGEMENT

A. Overview

In this appendix you will find information on:

- appropriate laws, regulations, and conventions related to NPS museum collections
 - governmentwide and departmental standards related to NPS museum collections
 - NPS management policies and servicewide standards for museum collections
 - mandates and policies for NPS integrated pest management programs
-

B. Laws, Regulations, and Conventions – NPS Cultural Collections

1. *Laws related to NPS cultural collections*

These laws provide the legal mandates for NPS management of museum collections.

- Act for the Preservation of American Antiquities, June 8, 1906 (“The Antiquities Act”) (16 USC 431-433):
 - authorizes the President to declare national monuments to protect sites and objects
 - authorizes federal departments to grant permits for survey and excavation and to enforce protection of archeological sites and objects under their jurisdiction
 - requires that excavated materials be permanently preserved in public museums
- Organic Act of 1916 (16 USC 1 et seq.):
 - authorizes the creation of the National Park Service
 - states that the mission of the NPS is “...to conserve the scenery and the natural and historic objects...therein and to provide for the enjoyment of the same in such a manner and by such means as will leave them unimpaired for the enjoyment of future generations”
- Historic Sites Act of 1935 (16 USC 461-467) authorizes the Secretary of the Interior through NPS:
 - to preserve and maintain objects of national historical or archeological significance
 - to establish and maintain museums

- Museum Properties Management Act of 1955, as amended (16 USC, Sect. 18 [f]) authorizes the Secretary of the Interior through NPS:
 - to acquire collections through donation, bequest, and purchase and through transfer from other federal agencies
 - to exchange collections
 - to accept and make loans of museum collections
 - to deaccession collections by transfer to qualified federal agencies, conveyance (donation) to qualified tax exempt private institutions and non-federal governmental agencies, and destruction

See Figure A.1 for the complete text of this law.

- Reservoir Salvage Act of 1960, as amended (16 USC 469 - 469C):

provides for the recovery and preservation of “historical and archeological data (including relics and specimens)” that might be lost or destroyed as a result of the construction of dams and reservoirs.
- Archeological and Historic Preservation Act of 1974 (16 USC 469-469C):

extends the application of the Reservoir Salvage Act of 1960 to recover and preserve “historical and archeological data (including relics and specimens)” that might be lost or destroyed as a result of any federal construction project or federally-licensed activity or program.
- National Historic Preservation Act of 1966, as amended (16 USC 470 - 470t, Sect. 110):

directs the Secretary of the Interior to issue regulations that ensure that significant prehistoric and historic artifacts, and associated records, subject to Section 110 of this Act, the Reservoir Salvage Act (as amended), and the Archaeological Resources Protection Act are deposited in an institution with adequate long-term curatorial capabilities.
- Archaeological Resources Protection Act of 1979 (ARPA) (16 USC 470aa-mm):
 - defines archeological resources as any material remains of human life or activities that are at least 100 years of age, and which are capable of providing scientific or humanistic understandings of past human behavior, cultural adaptation, and related topics through the application of scientific or scholarly techniques
 - requires that a permit be obtained before conducting archeological studies on public and Indian lands
 - requires that information on the nature and location of resources on public and Indian lands remain confidential if its release may harm the resources

- establishes civil and criminal penalties for the excavation, removal, or damage of resources on public and Indian lands without a permit (materials lawfully acquired prior to the passage of the law are not subject to the penalties)
- requires that materials excavated from public lands and Indian lands and associated records be preserved in a suitable repository
- gives the Secretary of the Interior authority to issue regulations for the proper curation of federally-owned and administered archeological collections
- American Indian Religious Freedom Act of 1978 (42 USC 1996):
reaffirms the constitutional right of “freedom to believe, express, and exercise the traditional religions of the American Indian, Eskimo, Aleut, and Native Hawaiians, including but not limited to access to sites, use, and possession of sacred objects, and the freedom to worship through ceremonials and traditional rites”
- Native American Graves Protection and Repatriation Act of 1990 (NAGPRA) (25 USC 3001-13):
 - states that lineal descendants or culturally affiliated Indian tribes or Native Hawaiian Organizations may claim ownership or control of Native American human remains, funerary objects, sacred objects, and objects of cultural patrimony that are excavated or discovered on federal or tribal lands after passage of the law
 - establishes criminal penalties for trafficking in remains or objects obtained in violation of the law
 - requires federal agencies and museums that receive federal funding to inventory Native American human remains and associated funerary objects in their possession or control and identify their cultural and geographical affiliations within 5 years
 - requires federal agencies and museums that receive federal funding to prepare summaries of information about Native American unassociated funerary objects, sacred objects, or objects of cultural patrimony within 3 years

Note: The inventories and summaries provide for repatriation of items when lineal descendants or Native American groups request it.
- National Parks Omnibus Management Act of 1998 (16 USC 5937) Sec. 5937:
 - establishes the confidentiality of sensitive information regarding certain types of museum objects and other resources
 - mandates a program of inventory and monitoring for NPS resources
 - allows the withholding of information (in response to a Freedom of Information Act request) on the nature and specific location of resources (specimens) that are endangered, threatened, rare, or commercially valuable, mineral or paleontological, and of objects of cultural patrimony

2. *Regulations related to NPS cultural collections*

The following regulations include major requirements for NPS museum collections management. Many other regulations may apply in specific situations.

- 43 CFR Part 3 “Preservation of American Antiquities” (implementing regulations for the Antiquities Act):
 - authorizes federal land managers to seize materials recovered illegally from archeological resources located on federal lands
 - directs federal land managers to dispose of seized materials by depositing them in the proper national depository or by other means
 - requires that every collection recovered under the Antiquities Act be preserved in the public museum designated in the Antiquities Act permit, and be accessible to the public
 - states that the Secretary of the Smithsonian Institution must approve in writing the removal (deaccession) of an Antiquities Act collection
 - mandates that deaccessioned Antiquities Act collections must be transferred to another public museum
 - requires that an Antiquities Act collection revert to the national collections whenever a museum holding such collections ceases to exist
- 43 CFR Part 7 “Protection of Archeological Resources: Uniform Regulations”:
 - requires that repositories proposed by ARPA permit applicants to certify in writing their willingness to assume curatorial responsibility for the collections
 - requires that, for resources located on public lands, repositories must certify that they will safeguard and preserve the collections as property of the United States
 - requires that ARPA permit applicants certify that, not later than 90 days after the final report is submitted to the federal land manager, the collections will be delivered to the repository named in the ARPA permit
 - requires that federal land managers specify in ARPA permits the name of the repository in which collections are to be deposited
 - states that archeological resources excavated or removed from public lands remain the property of the United States
 - states that archeological resources excavated or removed from Indian lands remain the property of the Indian or Indian tribe having rights of ownership over such resources
 - authorizes the Secretary of the Interior to issue regulations for the curation of federally-owned and administered collections. In the absence of such regulations Federal land managers are authorized

to provide for the exchange of collections among suitable repositories

- restates the confidentiality requirement specified in ARPA
- 36 CFR Part 79 “Curation of Federally-Owned and Administered Archeological Collections”:
 - states the responsibilities of federal agencies to manage and preserve collections
 - identifies methods for federal agencies to use to secure and fund curatorial services
 - states terms and conditions for federal agencies to include in contracts, memoranda, agreements, and other written instruments with repositories for curatorial services
 - establishes standards for federal agencies to use to determine when a repository has the capability to provide long-term curatorial services
 - provides guidelines for collections use
 - specifies procedures and guidelines for conducting periodic inspections and inventories of collections

3. *International Conventions related to NPS cultural collections*

The following international convention applies to NPS cultural collections.

- 1970 UNESCO Convention on the Means of Prohibiting and Preventing the Illicit Import, Export, and Transfer of Ownership of Cultural Property (implemented in the United States by P.L. 97-446 in 1983, 19 USC 2601). Signatory nations agree to work to prevent the import of and trade in archeological and ethnographic materials (when requested) and in stolen cultural collections. This convention:
 - was ratified by the United States and 90 other nations by 2000.
 - provides protection for archeological and ethnographic materials when the home nation requests that other signatories not import these materials. (As of 2000, Bolivia, Cambodia, Canada, Cyprus, El Salvador, Guatemala, Mali, and Peru have had such requests approved.)
 - provides protection for stolen property, including cultural and natural history collections, that have been taken from a museum or public institution (including churches, monuments, and archeological sites) To be covered, the materials must have been previously inventoried as part of the institution’s collection.
 - exempts objects imported for temporary exhibits

Note: The United States and France are the only major art-importing countries to sign the convention to date; Canada, Korea, and Australia are also signatories. It is enforced in the United States by the Customs Service.

4. *Contacts for laws, regulations, and conventions – NPS cultural collections*

Direct questions relevant to laws and regulations about cultural collections to the regional/support office (SO) curator, the regional archeologist, historian, archivist, and ethnographer.

For information on the 1970 UNESCO Convention on the Means of Prohibiting and Preventing the Illicit Import, Export, and Transfer of Ownership of Cultural Property, contact:

Cultural Property Advisory Committee
United States Department of State
SA 44, Room 247
Washington, DC 20547

Telephone: 202-619-6612
Fax: 202-619-5177
Email: culprop@usia.gov
<http://exchanges.state.gov/education/culprop>

C. Laws, Regulations, and Conventions – NPS Natural History Collections

1. *Laws related to NPS natural history collections*

These laws relate to NPS natural history collections.

- Lacey Act of 1900 (18 USC 43-44):
 - makes the violation of any state, federal, or foreign wildlife law a federal offense
 - places stipulations on the importing and labeling of wildlife and their parts
 - poses complex problems for museums in relation to the acquisition and deaccession of wildlife materials and the sale of wildlife materials in museum shops because it is hard to prove the legal history of such pieces
 - requires proof of intentional violation for enforcement, but ignorance of the relevant state, federal, or foreign statutes is not excusable.

Note: The Black Bass Act of 1930 (16 USC 851) added fish to the list of wildlife under the Lacey Act.

- Migratory Bird Treaty Act of 1918 (16 USC 703-711):
 - protects birds flying between the United States and Canada, Mexico, and Japan
 - covers all wild, native birds not legally hunted by state law
 - clarifies that some non-native species may be covered by state law and, therefore, by the Lacey Act

- makes it illegal to kill, capture, collect, possess, buy, sell, ship, import, or export listed species including their parts, nests, and eggs
- allows museums and non-commercial institutions to get permits for legal possession, collection, and transportation of objects, but permits impose extensive record-keeping requirements
- states that only museums and other specified institutions can purchase any protected bird or part thereof, and the seller must possess a federal permit for a legal sale
- Bald Eagle Protection Act of 1940 (16 USC 668a), amended in 1962 to include golden eagles:
 - prohibits taking, buying, selling, trading, possession, importation or exportation of eagles or their parts, nests, eggs, or products made of them
 - authorizes permits for taking, possessing, and transporting eagles and their parts for scientific, exhibition, and Native American religious purposes
 - exempts possession and transportation of eagles held prior to the law
 - requires permits for any materials acquired by museums after the law was established
- Marine Mammal Protection Act of 1972 (16 USC 1361-1407):
 - places a moratorium on the killing of marine mammals by United States citizens
 - restricts the possession, sale, purchase, importation, or transportation of the animals and their products and parts
 - requires permits for exhibiting marine mammals and their parts and for holding them in storage.
 - allows Native peoples to use such parts for the manufacture and sale of handcrafts as long as the sale is handled by a licensed dealer
 - exempts museums from permit requirements for pre-Act materials or to purchase legitimate handcrafts, although they should consider getting permits for all other marine mammal materials.
- Endangered Species Act of 1973, as amended (16 USC 1531-1543):
 - prohibits harassing, harming, or killing listed species
 - prohibits the purchase, sale, or use of listed species or parts thereof in the course of an interstate commercial activity. Intra-state transactions are allowed if pre-Act ownership can be proven.
 - doesn't apply to fossils and objects greater than 100 years old, but age must be verified

- requires park museums to have a permit to purchase more recent objects that contain parts of endangered or threatened species
- allows gifts of endangered or threatened specimens to museums if there is proof of pre-Act ownership and if the objects have not been offered for sale since the date of this law.
- allows loans or gifts between educational institutions. In such instances permits are not required, even if the objects cross state lines.

2. *Regulations related to NPS natural history collections*

The following regulations apply to NPS museum collections.

- 36 CFR, Section 2.5 (Revision effective April 30, 1984), “Research Specimens” Section 2.5(g) states: “Specimen collection permits shall contain the following conditions:
 - Specimens placed in displays or collections will bear official National Park Service museum labels and their catalog numbers will be registered in the National Park Service National Catalog.
 - Specimens and data derived from consumed specimens will be made available to the public and reports and publications resulting from a research specimen collection permit shall be filed with the superintendent.”

Note: A revision to 36 CFR 2.5 is in progress.

- 50 CFR, Sections 17.11 and 17.12, “Endangered and Threatened Wildlife and Plants.” These annually revised sections provide lists of names of all the species of wildlife and plants determined to be endangered or threatened.

3. *International conventions related to NPS natural history collections*

The following international convention applies to NPS natural history collections.

- Convention on International Trade in Endangered Species of Wild Fauna and Flora (CITES):
 - protects endangered species of plants and animals by regulating imports and exports
 - was ratified by the United States in 1974, and by 150 other nations by 2000
 - allows for certificates of exemption for the import or export of items acquired before CITES, and for non-commercial exchange between institutions
 - is enforced in the United States by the Fish and Wildlife Service
 - includes three appendices that protect materials of varying degrees of scarcity:

Appendix I. Species are in danger of extinction and there is no commercial trade in them. Any international transport of these materials requires permits from both the exporting and importing nations.

Appendix II. Species require strict regulation to prevent the danger of extinction and/or look like Appendix I species. Permits for international transport are issued by the exporting nation, and are allowed for any purpose not detrimental to the species.

Appendix III. Species are protected only within their native countries. They require permits for export even if they are plentiful elsewhere.

4. *Contacts for laws, regulations, and conventions – NPS natural history collections*

Direct questions relevant to the Endangered Species Act, and other laws and regulations about natural history collections to the regional/SO curator and the regional chief of natural resources management (or equivalent).

For information on CITES and other wildlife laws, including procedures and applications for getting permits to have endangered or threatened wildlife and plants in a park's museum collection, contact:

U.S. Department of the Interior
Fish and Wildlife Service
Office of Management Authority
4401 North Fairfax Drive, Room 700
Arlington, VA 22203

Tel: 703-358-2104
<<http://international.fws.gov/global/cities.html>>

CITES Secretariat
15 chemin des Anemones
1219 Chatelaine-Geneva
Switzerland

<<http://www.cites.org>>

D. Policies and Standards

1. *Governmentwide and departmental policies and standards related to NPS museum collections*

The following governmentwide and departmental policies and standards apply to NPS museum collections:

- 41 CFR 101 Federal Property Management Regulations (FPMR) prescribes regulations, policies, procedures, and delegations of authority about the management of federal property.
- Interior Property Management Regulations, *Departmental Manual* Part 410, Personal Property Management (Subpart 114-60):
 - prescribes policies, procedures, and responsibilities governing the receipt, accountability, record-keeping, management, and survey of personal property in the Department of the Interior (DOI)
 - applies to all personal property acquired by all DOI bureaus and offices
 - ensures the safeguarding of government property against waste, fraud, and abuse

- references the management of museum collections, noting exceptions to normal property procedures. These references are summarized in Figure A.2.
- *Departmental Manual* Part 411, Museum Property Management, Chapters 1-3:
 - defines the types of museum property
 - establishes organizational responsibilities, policies, and standards for the preservation, protection, and documentation of museum property
 - establishes organizational responsibilities for developing plans to implement these policies and standards
 - identifies mandatory procedures, reports, and data
- *Departmental Manual* Part 517, Chapter 1, Pesticide Use Policy, outlines the pesticide use policy of the Department of the Interior. It is the policy of the Department:

“To use pesticides only after full consideration of alternatives - based on competent analyses of environmental effects, safety, specificity, effectiveness, and costs. The full range of alternatives including chemical, biological, and physical methods, and no action will be considered. When it is determined that a pesticide must be used in order to meet important management goals, the least hazardous material that will meet such goals will be chosen.”

2. *NPS management policies for museum collections*

Excerpts from *NPS Management Policies* (1988) that are specifically relevant to museum objects are as follows (chapter and page references appear in parentheses). This section will be updated when the revised *Management Policies* is issued (anticipated fall 2000).

Chapter 5 - Cultural Resource Management

Inventories (Page 5:1)

“The following cultural resource inventories will be maintained for the national park system: ...(3) a National Catalog of Museum Objects encompassing all cultural and natural history objects in NPS collections.”

Preservation of Data and Collections and Protection of Research Potential (Page 5:3)

“Field data, objects, specimens, and features of structures retrieved for preservation during cultural resource research and treatment projects, together with associated records and reports, will be managed within the park museum collection. Where practical, the features of sites and structures will be left in place.”

Treatment of Museum Objects (Pages 5:9-10)

“Preservation. A museum object will be preserved in its present condition through ongoing preventive conservation if (1) that condition is satisfactory for exhibit or research, or (2) another treatment is

warranted but cannot be accomplished until some future time. Interventional measures will be taken when preventive conservation measures are insufficient to reduce deterioration to a tolerable level, or when the object is so fragile as to be endangered under any circumstances. Intervention will be minimized to reduce the possibility of compromising the object's integrity.

Restoration. A museum object may be restored to an earlier appearance if (1) restoration is required for exhibit or research purposes, (2) sufficient data exist to permit restoration with minimal conjecture, and (3) restoration will not modify the object's known original character. Restoration will be accomplished using the techniques and materials that least modify the object and in such manner that the materials will be removable at a later time with minimal adverse effect. Restored areas will be distinguishable from original material and documented. Restoration will take into account the possible importance of preserving signs of wear, damage, former maintenance, and other historical and scientific evidence.

Reproduction. Museum objects needed for interpretive presentations will be reproduced for such use when the originals are unavailable or would be subject to undue deterioration or loss. The National Park Service will observe copyright laws with respect to reproduction."

Acquisition, Management, and Disposition of Museum Objects (Page 5:10)

"Objects and related documentation essential to achieving the purposes and objectives of the parks will be acquired and maintained in accordance with approved Scope of Collection Statements for each park. Archeological objects systematically collected within a park and natural history specimens systematically collected within a park for exhibit or permanent retention will be managed as part of the museum collection. Museum collection management and care will be addressed at all appropriate levels of planning.

Museum objects will be acquired and disposed of in conformance with legal authorizations and current NPS curatorial procedures. The National Park Service will acquire only collections having legal and ethical pedigrees, and each park will maintain complete and current accession records to establish the basis for legal custody of the objects in its possession. Museum catalog records will be prepared by each park to record basic property management data and other documentary information for museum objects. Objects will be inventoried in accordance with current procedures."

Historic Furnishings (Page 5:10)

"When the historic furnishings of a structure are present in their original arrangement, they will not be moved or replaced unless required for their protection or preservation, or unless the structure is designated for another use in an approved planning document. A structure may be refurnished in whole or in part if (1) its history is significantly related to a primary park theme, (2) refurnishing is the best way to interpret that history to the public, and (3) sufficient evidence of furniture design and placement exists to refurnish with minimal conjecture. Reproductions will be used only when prototypes exist to ensure the accurate re-recreation of historic pieces."

Archives and Manuscripts (Pages 5:10-11)

“Archival and manuscript collections are considered museum property and will be managed in ways that preserve them intact for the future while providing current access.

When an archival collection not owned by the National Park Service falls within a park’s approved Scope of Collection Statement, every reasonable effort will be made to acquire it if (1) an appropriate storage facility will be provided by the Park Service or a cooperating institution, (2) the facility will be staffed by at least one archivist, curator, librarian, or other person experienced in caring for documentary materials, and (3) the collection will be made available to serious researchers under conditions that maximize both preservation and use and ensure security against theft and vandalism.

Parks will retain notes or copies of records significant to their administrative histories when they periodically ship their official records to federal record centers.”

Fire Detection and Suppression (Page 5:14)

“When warranted by the significance of a historic structure or of the museum objects in a nonhistoric structure, adequate fire detection, warning, and suppression systems will be installed. Fire-fighting personnel will be advised of any peculiarities or dangers inherent in a structure and any objects to be given priority for protection or rescue. Park personnel will receive training in fire prevention and suppression with hand-held extinguishers at historic structures and museums, and designated personnel will be trained to respond to all emergencies involving museum collections.

Smoking will not be permitted in spaces housing museum collections or in historic structures other than those adapted for modern residential and administrative uses.”

Pest Management (Page 5:14)

“The National Park Service will follow the integrated pest management approach in addressing pest problems related to cultural resources. All feasible nonchemical methods will be exhausted before resorting to the use of chemicals. Any use of pesticides for cultural resources will conform to the NPS pesticide use policy.”

Chapter 4 - Natural Resource Management

Natural Resource Collections (Page 4:4)

“Natural resource collections include nonliving and living specimens and associated field records. If placed in exhibits or retained in permanent collections, nonliving specimens and their associated field records will be cataloged into a park’s museum collection. Management standards for such collections are specified in the *Cultural Resource Management Guideline* and the *Museum Handbook*.”

Integrated Pest Management Procedures (Page 4:13)

Integrated pest management (IPM) procedures will be used to determine when to control pests and whether to use mechanical, physical, chemical, cultural, or biological means....

The choice to use a chemical pesticide will be based on a review by regional and Washington office coordinators of all other available options and a determination that these options are either not acceptable or not feasible; cost or staffing considerations alone will not be adequate justification for use of chemical control agents. Chemical pesticides that are not specifically exempt from reporting (regardless of who the applicator is) will be used only with prior approval by the Director on an annual basis. The application of such pesticides is subject to the Federal Insecticide, Fungicide, and Rodenticide Act (7 USC 136 et seq.), Department of the Interior policies and procedures (DM 517),...Environmental Protection Agency regulations in 40 CFR, and Occupational Safety and Health Administration regulations.”

Paleontologic Resource Management (Page 4:19)

“Management actions will be taken to prevent illegal collecting and may be taken to prevent damage from natural processes such as erosion. Protection may include construction of shelters over specimens for interpretation in situ, stabilization in the field, or collection, preparation, and placement of specimens in museum collections. The localities and geologic settings of specimens will be adequately documented when specimens are collected.”

Chapter 7 - Interpretation and Education

Interpretation and Native Americans (Page 7:5)

“The National Park Service will not exhibit native American disinterred skeletal or mummified human remains or photographs or replicas of them. There will be no display of grave goods or other objects if native Americans who are culturally associated with them object to such exhibit. Associated native American tribes and groups will be consulted to determine the religious status of any object, the sacred nature of which is suspected but not confirmed, before it is exhibited or before any action is taken.”

Chapter 8 - Use of the Parks

Research and Collection Activities (Pages 8:15-16)

“Research activities by non-NPS personnel that, in the superintendent’s judgment, might disturb resources or visitors or that require the waiver of any regulation may be allowed in parks only pursuant to the terms and conditions of an appropriate permit. Scientific collecting activities that involve the removal of plants, animals, minerals, or archeological, historical, or paleontological objects will be allowed only if they are (1) proposed in conjunction with authorized research activities and (2) authorized and conducted in accordance with all applicable legislation, regulations, and guidelines....”

Chapter 9 - Park Facilities

Curatorial Facilities (Page 9:15)

“Park curatorial facilities should be adapted to the needs of each park. They may share space in visitor centers or administrative office buildings or be housed in completely separate buildings; however, incorporation with maintenance facilities should be avoided because of the heightened danger of fire, chemical spills, and similar accidents. Curatorial facilities will meet the collection’s special requirements for security, fire suppression, and environmental controls.”

Chapter 10 - Concessions Management

Merchandise and Handcrafts (Pages 10.8-9)

“Concessioners may not sell merchandise that violates conservation principles. The sale of original prehistoric or historic archeological artifacts or vertebrate paleontologic specimens is prohibited. Clearly labeled replicas of such artifacts and specimens may be sold.”

3. *NPS Director’s Orders and guidance for museum collections*

Director’s Order #28: Cultural Resource Management

Director’s Orders supplement the *NPS Management Policies*. All Director’s Orders are on the Web at <<http://www.nps.gov/refdesk/DOorders/>>.

Director’s Order #28: Cultural Resource Management, is implemented through Release No. 5 of the *Cultural Resource Management Guideline* (1997). The *Cultural Resource Management Guideline* gives guidance on how to apply policies and standards. The *Cultural Resource Management Guideline* applies to museum objects and archival and manuscript collections that are housed in parks, archeological and preservation centers, and other NPS organizational units. Excerpts from this guideline follow:

Research

- Each park has an approved stand-alone Scope of Collection Statement defining the purpose and prescribing limits and use of its museum collection.
- Every museum object is accessioned as soon as it is in NPS custody and cataloged promptly thereafter. Paper museum records and ANCS+ magnetic media are kept in secure fire-resistant storage.
- All materials resulting from systematic research projects associated with an accession are housed at the same repository, except when on temporary loan for specific use elsewhere. Within that repository, objects and records composing an accession may be stored or filed separately from related objects and records to the extent required for security, fire protection, enhanced or reduced access, preservation, fiscal control, or exhibition.
- Each park has consulted with affected Native Americans on any acquisitions that involve human remains and associated funerary objects, unassociated funerary objects, sacred objects, or objects of cultural patrimony.

- Archival and manuscript collections are surveyed, appraised, accessioned, cataloged, rehoused, arranged, and described according to procedures and guidelines contained in the *Museum Handbook*, Part II, Appendix D.
- Archival and manuscript collections are arranged and described by or under the guidance of an archivist in accordance with professional standards and procedures. A preliminary finding aid is produced as described in the *Museum Handbook*, Part II, Appendix D.
- Museum objects not relevant to a park according to its SOCS are deaccessioned as permitted by current NPS procedures.
- Archeological objects and natural history specimens systematically collected within a park are deaccessioned only if lost or so deteriorated that they no longer have scientific value.
- Objects and archival and manuscript collections in a park's museum collection are made available to qualified researchers who can demonstrate a need to use them. Access is permitted under conditions designed to ensure the security and preservation of the materials, including adequate staff supervision. Copyright is respected in accordance with guidance in the *Museum Handbook*, Part I, Chapter 2; the *Museum Handbook*, Part II, Chapter 2 and Appendix D.
- Each outgoing loan is documented by an outgoing loan agreement. All loaned museum objects are cataloged unless loaned to NPS repositories for collections management and storage purposes. Conditions for preserving, handling, and shipping and an itemized list of museum objects are included in a loan agreement.

Planning

- Plans for park management, development, exhibits, interpretation, and research address the proper documentation, protection, preservation, and use of objects.
- Each park and center has a collection management plan to guide proper management and care of its museum collection and a separate collection storage plan if necessary.
- Each park and center has one or more collection condition surveys to detect problems with the condition of museum objects and determine conservation treatment priorities.
- Proposals for environmental control measures in historic structures are based on data from environmental monitoring for at least one year.
- Each park ensures that the cataloging and curation of objects, specimens, and associated records recovered from archeological and scientific projects are accomplished.
- Each park ensures that approved museum plans and reports are entered in the Cultural Resources Management Bibliography (CRBIB).

Stewardship

- Each park and center has identified threats to the security and protection of its museum collection and has taken appropriate measures to deal with them, including emergency planning.
- Each park and center has implemented a preventive conservation program whereby museum objects are exhibited, handled, and stored with sensitivity to their specific environmental needs and vulnerabilities and are regularly inspected for evidence of deterioration.
- Preservation and use of museum objects accords with Director's Order #24: NPS Museum Collections Management; the *Museum Handbook*, Part I; and National Archives and Records Administration standards.
- Conservation treatment required to stabilize or restore museum objects entails the least intervention necessary to satisfy treatment goals.
- Inventories of museum objects and status reports on collections are completed and submitted in accordance with current NPS museum property procedures and other administrative requirements.
- Any use of museum objects likely to damage them or hasten their deterioration is undertaken only after careful review and approval.

*Director's Order #24: NPS
Museum Collections
Management*

Director's Order #24: NPS Museum Collections Management, gives requirements for managing park museum collections. It is supplemented by the *Museum Handbook*, Parts I-III. Director's Order #24 is reprinted in full in Figure A.3.

E. List of Figures

Figure A.1. Museum Properties Act of 1955 as Amended November 12, 1996.....	A:17
Figure A.2. References to Museum Collections Management in Interior Property Management Regulations.....	A:18
Figure A.3. Director's Order #24: NPS Museum Collections Management	A:19

16 USC Sec. 18f Management of museum properties

The purpose of this section and sections 18f-2 and 18f-3 of this title shall be to increase the public benefits from museums established within the individual areas administered by the Secretary of the Interior through the National Park Service as a means of informing the public concerning the areas and preserving valuable objects and relics relating thereto. The Secretary of the Interior, notwithstanding other provisions or limitations of law, may perform the following functions in such manner as he shall consider to be in the public interest:

- (a) Donations and bequests—Accept donations and bequests of money or other personal property, and hold, use, expend, and administer the same for purposes of this section and sections 18f-2 and 18f-3 of this title;
- (b) Purchases—Purchase museum objects, museum collections, and other personal properties at prices he considers to be reasonable;
- (c) Exchanges—Make exchanges by accepting museum objects, museum collections, and other personal properties, and by granting in exchange therefore museum property under the administrative jurisdiction of the Secretary which is no longer needed or which may be held in duplicate among the museum properties administered by the Secretary, such exchanges to be consummated on a basis which the Secretary considers to be equitable and in the public interest;
- (d) Accepting loans of museum objects—Accept the loan of museum objects, museum collections, and other personal properties and pay transportation costs incidental thereto, such loans to be accepted upon terms and conditions which he shall consider necessary; and
- (e) Making loans of museum objects—Loan to responsible public or private organizations, institutions, or agencies, without cost to the United States, such museum objects, museum collections, and other personal property as he shall consider advisable, such loans to be made upon terms and conditions which he shall consider necessary to protect the public interest in such properties.

Sec. 18f-1. [Does not apply to the National Park Service.]

Sec. 18f-2. Additional functions

- (a) Museum objects and collections—In addition to the functions specified in section 18f of this title, the Secretary of the Interior may perform the following functions in such manner as he shall consider to be in the public interest:
 - (1) Transfer museum objects and museum collections that the Secretary determines are no longer needed for museum purposes to qualified Federal agencies, including the Smithsonian Institution, that have programs to preserve and interpret cultural or natural heritage, and accept the transfer of museum objects and museum collections for the purposes of this section and sections 18f and 18f-3 of this title from any other Federal agency, without reimbursement. The head of any other Federal agency may transfer, without reimbursement, museum objects and museum collections directly to the administrative jurisdiction of the Secretary of the Interior for the purpose of this section and sections 18f and 18f-3 of this title.
 - (2) Convey museum objects and museum collections that the Secretary determines are no longer needed for museum purposes, without monetary consideration but subject to such terms and conditions as the Secretary deems necessary, to private institutions exempt from Federal taxation under section 501(c)(3) of title 26 and to non-Federal governmental entities if the Secretary determines that the recipient is dedicated to the preservation and interpretation of natural or cultural heritage and is qualified to manage the property, prior to any conveyance under this subsection.
 - (3) Destroy or cause to be destroyed museum objects and museum collections that the Secretary determines to have no scientific, cultural, historic, educational, esthetic, or monetary value.
- (b) Review and approval—The Secretary shall ensure that museum collections are treated in a careful and deliberate manner that protects the public interest. Prior to taking any action under subsection (a) of this section, the Secretary shall establish a systematic review and approval process, including consultation with appropriate experts, that meets the highest standards of the museum profession for all actions taken under this section.

Sec. 18f-3. Application and definitions

- (a) Application—Authorities in this section and sections 18f and 18f-2 of this title shall be available to the Secretary of the Interior with regard to museum objects and museum collections that were under the administrative jurisdiction of the Secretary for the purposes of the National Park System before November 12, 1996, as well as those museum objects and museum collections that may be acquired on or after November 12, 1996.
- (b) Definitions—For the purposes of this section and sections 18f and 18f-2 of this title, the terms “museum objects” and “museum collections” mean objects that are eligible to be or are made part of a museum, library, or archive collection through a formal procedure, such as accessioning. Such objects are usually movable and include but are not limited to prehistoric and historic artifacts, works of art, books, documents, photographs, and natural history specimens.

Figure A.1. Museum Properties Act of 1955 as amended November 12, 1996

- 114-60.100(b) All museum property is accountable with no dollar threshold.
- 114-60.100(e) Museum property is not capitalized.
- 114-60.100(n) Definition of museum property
- 114-60.100(bb) Sensitive property shall, at a minimum, include firearms...
- 114-60.200(a) (1)...museum property will not be controlled in a general ledger control account. All items in a museum collection will be controlled through accessioning and cataloging.
- 114-60.401(c) All museum property is controlled through accessioning and cataloging, regardless of value.
- 114-60.503(e) An Accession Receiving Report will be used to document receipt of museum property.
- 114-60.601(b) Because permanent marking of museum property is potentially damaging, items of museum collections are exempted from the marking requirements of this subpart. Bureaus and offices having museum collections will develop and implement procedures: (NPS procedures are outlined in the *NPS Museum Handbook*, Part II).
- 114-60.802-1(a) A Certificate on Unserviceable Property will not be issued for...museum property.
- 114-60.811-2(f) Examples of property irregularities include...loss or theft of a firearm or weapon.

Figure A.2. References to Museum Collections Management in Interior Property Management Regulations, *Departmental Manual Part 410, Personal Property Management (Subpart 114-60)*

Figure A.3. Director's Order #24: NPS Museum Collections Management



National Park Service

DIRECTOR'S ORDER #24: NPS MUSEUM COLLECTIONS MANAGEMENT

Approved: /s/ Robert Stanton (original on file)
Director, National Park Service

Effective Date: August 21, 2000

Sunset Date: August 21, 2004

This Director's Order supplements NPS *Management Policies* and, augmented by procedures in the *Museum Handbook*, supercedes Special Directives 80-1, "Guidance for Meeting NPS Preservation and Protection Standards for Museum Collections"; 87-3, "Conservation of Archeological Resources," as it pertains to museum collections; 91-4, "Ensuring that Natural Resource Projects Fund the Curation of Collections"; 94-6, "Ensuring that Projects Generating Museum Collections Fund Cataloging and Basic Preservation"; 93-2, "Preserving NPS Cellulose Nitrate Film Collections"; and Staff Directive 87-1, "NPS Clearinghouse Procedures and Requirements Regarding Disposal and Acquisition of Excess and Needed Museum Objects."

1. Background and Purpose

The National Park Service is custodian in perpetuity of irreplaceable and priceless museum collections that include objects, specimens, and archival and manuscript materials (textual, electronic, and audio-visual documents), representing cultural and natural resources in the United States, including but not limited to the disciplines of archeology, biology, ethnology, geology, history, and paleontology. NPS museum collections are part of the natural and cultural heritage of the country and are collected, preserved, and interpreted for public benefit.

NPS museum collections inform and enhance every aspect of park work, from resource management and interpretation, to research and public accountability. Featured in exhibits, interpretive programs, films, and print and electronic publications, NPS museum collections are key resources for educators, students, researchers, park managers, park neighbors, and the general public. Accessibility of museum collections is a prime component of museum management.

The NPS *Management Policies* lay the foundation by which the NPS meets its responsibilities toward these museum collections. This Director's Order provides further policy guidance, standards, and requirements for preserving, protecting, documenting, and providing access to, and use of, NPS museum collections.

2. Authority for this Director's Order

Authority for issuing this Director's Order is found in 16 U.S.C. 1 through 4, and delegations of authority contained in Part 245 of the Department of the Interior Manual. Additional key related authorities are found in the Antiquities Act of 1906 (16 U.S.C. 431-433), the Historic Sites Act of 1935 (16 U.S.C. 461-467), the Management of Museum Properties Act of 1955, as amended (16 U.S.C. 18f), the Archaeological Resources Protection Act of 1979 (16 U.S.C. 470aa-mm), the Native American Graves Protection and Repatriation Act of 1990 (25 U.S.C. 3001), and the Departmental Manual 411 DM, Managing Museum Property.

3. Objectives

The objectives of this Director's Order, in conjunction with the accompanying Level 3 *Museum Handbook*, are to:

- Ensure that NPS managers and staff have information on the standards and actions for successfully and ethically complying with NPS *Management Policies* on museum collections.
- Provide a means of measuring and evaluating progress in preserving, protecting, documenting, accessing, and using museum collections.

4. Responsibilities

4.1 Associate Director, Cultural Resource Stewardship and Partnerships

The Associate Director, Cultural Resource Stewardship and Partnerships, with the assistance of the Chief Curator, has the following responsibilities:

4.1.1 Code of Ethics: Follow the Code of Ethics for the museum management program.

4.1.2 Museum Handbook: Develop, issue, and periodically update a *Museum Handbook* containing the information park managers need to know to comply with laws, departmental and Service-wide policies, regulations, professional standards, and a code of ethics applicable to museum collections management. Include in the *Museum Handbook*, as a supplement to this Director's Order, specific guidance for collecting, preserving, protecting (including security and fire protection), documenting, accessing, and using museum collections, clearly distinguishing between those actions that are mandatory requirements and those that are discretionary. Cite those laws, policies, and regulations in relevant sections.

4.1.3 Strategic Plans: Develop strategic plans and goals to improve and maintain the management of NPS museum collections Service-wide, consistent with the Government Performance and Results Act of 1993 (31 USC 1115).

4.1.4 National Catalog: Maintain for management and public benefit a National Catalog of Museum Objects, consisting of electronic and paper catalog records, with accession and catalog data for all parks. Develop and maintain an automated collections management program (the Automated National Catalog System [ANCS+ and its successor]) for use by parks, centers, and offices Service-wide, as well as the general public.

4.1.5 Report Requirements and Analysis: Identify reports that are required annually, or at other times, to further museum collections management. Reporting requirements will be kept to the minimum necessary. Maintain, analyze, and report on data submitted by parks, centers, and regions, including: the Collections Management Report, the NPS Checklist for Preservation and Protection of Museum Collections; funding distributions and accomplishments; and other required reports and surveys.

4.1.6 Annual Inventory: Review regional certifications of annual inventories, and take any necessary corrective action.

4.1.7 Museum Supplies, Equipment, and Technologies: Research products and facilitate park and center acquisition and use of appropriate supplies, forms, equipment, and technologies for management of museum collections.

4.1.8 Service-wide Initiatives: Develop and coordinate Service-wide initiatives and funding to improve museum management.

4.1.9 Technical Information: Publicize and disseminate technical information on museum management, including conservation and archival collections management.

4.1.10 Information Access: Develop and maintain access to Service-wide information on NPS museum collections through various media (for example, ANCS+ and World Wide Web).

4.1.11 Professional Qualifications and Training: Evaluate Service-wide professional competencies and training needs in museum management, and develop strategies, guidelines, and curricula to meet those needs. Coordinate training to address new technologies, programs, and initiatives.

4.1.12 Plan Review: Review draft park plans that receive Washington Office review, such as General Management Plans, for appropriate coverage of museum management.

4.1.13 Technical Assistance: Provide technical assistance and advice to park and center managers regarding acquiring, preserving, protecting, documenting, accessing, and using museum collections. Provide this assistance and advice at the request of regions.

4.2 Regional Directors and WASO Associate Directors with Museum Collections Responsibility

Regional directors (assisted by regional museum support staff), and WASO associate directors accountable for museum collections, have the following responsibilities:

4.2.1 Code of Ethics: Follow the Code of Ethics for the museum management program.

4.2.2 Plan and Performance Review: Use the strategic and annual performance planning processes, the park planning process, and the performance management system to ensure that superintendents and center managers meet their responsibilities to manage museum collections according to this directive. Review park plans for appropriate coverage of museum collections management, and to ensure consistency with NPS requirements.

4.2.3 Technical Assistance: Provide technical assistance to parks and centers to assist them in meeting NPS museum management requirements, and in providing for access and use of collections.

4.2.4 Staffing and Training: Evaluate museum management staffing and training needs, and develop and provide training to park and center staff. Regional directors will alert the Associate Director, Cultural Resource Stewardship and Partnerships, about regional training needs that may apply Service-wide.

4.2.5 Plans, Priorities, and Reports: Develop plans and set priorities (including funding priorities) for managing museum collections based on all approved planning documents and information provided through Service-wide reports and requirements, including the Collections Management Report, NPS Checklist for Preservation and Protection of Museum Collections, and Automated Inventory Program. Review reports to ensure that parks and centers meet reporting requirements.

4.2.6 Annual Inventory Certification: Annually certify to the Associate Director, Cultural Resource Stewardship and Partnerships, Attention: Chief Curator, no later than September 30 each fiscal year, that parks and centers have completed their annual inventories. Review park and center annual inventories and take any necessary corrective actions. Establish a regular schedule for parks in the region to submit the inventories.

4.2.7 Destructive Analysis and Consumptive Use: After careful review, if the benefits can be clearly shown to outweigh the resulting or potential damage or loss, approve destructive analysis of rare or highly significant objects, specimens, and archival items, and any consumptive use of museum collections.

4.2.8 Unconditional Gifts: Grant exceptions to the unconditional gift policy on a rare, and case-by-case basis.

4.3 Park Superintendents and Center Managers

Park superintendents, center managers, and others who manage collections (with the assistance of museum management staff) have the following responsibilities:

4.3.1 Code of Ethics: Follow the Code of Ethics for the museum management program.

4.3.2 Standards: Meet museum management standards in the NPS *Museum Handbook* (Parts I-III) for:

- acquiring, preserving, protecting, documenting (including accessioning, cataloging, lending, deaccessioning), accessing, and using museum collections; and
- completing actions specific to archival and manuscript collections (appraising, arranging, describing, producing finding aids, and providing reference and duplication services).

4.3.3 Procedures: Follow procedures in the *Museum Handbook*.

4.3.4 Ongoing and Corrective Actions: Provide ongoing funding for recurring museum management functions and take appropriate action to correct identified preservation, protection, documentation, and access and use deficiencies, including programming for funding to correct such deficiencies. Complete Project Management Information System (PMIS) and Resource Management Plan (RMP) project statements that identify all preservation, protection, documentation, access and use needs.

4.3.5 Staffing and Training: Evaluate and address museum management staffing and training needs according to established personnel qualifications standards and Service-wide professional competencies.

4.3.6 Scope of Collection: Approve and keep current a Scope of Collection Statement to identify the scope of collecting activities and define the purpose of the collection. Ensure acquisitions are consistent with the Scope of Collection Statement. Deaccession objects inconsistent with the Scope of Collection Statement.

4.3.7 Collection Management Plan: Approve, keep current, and implement a Collection Management Plan to:

- evaluate issues of preserving, protecting (including security and fire protection), documenting, accessing and using collections;
- address issues specific to archival and manuscript collections (appraising, arranging, describing, producing finding aids, and providing reference and duplication services); and
- propose a strategy to address the issues, including staffing and cost estimates.

4.3.8 Housekeeping Plan: Approve, keep current, and implement a Housekeeping Plan for every space that houses museum collections, to ensure that housekeeping routines are sensitive to museum collections preservation needs.

4.3.9 Integrated Pest Management: Approve, keep current, and implement an Integrated Pest Management Plan that addresses the museum collections.

4.3.10 Emergency Operation: Approve, keep current, and implement a Museum Collections Emergency Operations Plan, as part of the park's Emergency Operations Plan, that identifies museum collection vulnerabilities to events (such as fire, earthquakes, and floods), and identifies responses that will protect resources without endangering human health and safety. Ensure staff is practiced and prepared for emergency response.

4.3.11 Job Hazard Analysis: Complete a Job Hazard Analysis (JHA) for all museum jobs that have an associated history of injury, illness, or death; or that require the use of personal protection equipment, such as respirators; or that involve activities that are clearly dangerous, such as handling collections with mold, working with toxic or flammable chemicals, or operating heavy machinery.

4.3.12 Collection Condition: Monitor and record information about the environment in spaces housing collections and manage the environment to maximize preservation. Complete Collection Condition Surveys, as needed, to assess conditions in spaces housing museum collections, to record the condition of objects or groups of objects, and to determine treatment needs and priorities. Incorporate survey data in ANCS+ and in accession or catalog files.

4.3.13 Accession and Catalog Records: Accession collections upon acquisition to establish basic accountability. Catalog the collections immediately following acquisition, or program to catalog them in the

near future. Survey, appraise, rehouse, arrange, and describe archival and manuscript collections and prepare finding aids. Develop park archival duplication and reference procedures. Have PMIS statements in place to address eliminating any archival processing backlog.

4.3.14 Accession and Catalog Backup: Maintain a complete current backup of all electronic accession and catalog records at a location that is not vulnerable to the same catastrophic events as the computer workstation. Submit a complete annual backup to the National Catalog in Harpers Ferry, West Virginia.

4.3.15 Unconditional Gifts: Accept only unconditional gifts and bequests, and, where possible, obtain applicable copyrights and releases with acquisitions. Obtain regional director's approval for rare exceptions, on a case-by-case basis.

4.3.16 Project-generated Collections: Require project budgets to include funding for the basic management of collections that are project-generated. Collections management includes cataloging; labeling; conservation examination and treatment (including specimen preparation); initial storage of objects and specimens; and organization and storage of project documentation, including appraisal, arrangement, description, finding aid production, and appropriate archival housing.

- Before starting, permitting, or contracting a project, specify in writing in the task directive, proposal, agreement, permit, or contract, the parties responsible, the designated NPS or non-NPS repository, the collections management tasks, and a time schedule for completion.
- Fund subsequent ongoing maintenance costs of collections management from the operating base of the responsible park, center, or other repository.
- If project-generated collections cannot be accommodated in available storage space, and new storage space construction is necessary, program to construct new space to accommodate the expanded collection. If interim storage is needed, specify in the project task directive the location of that storage, and state that it must meet NPS standards. Identify the funding source for interim storage.

4.3.17 Systematic Collections: Add collections made through systematic research to the museum collection. House those associated with a single accession at the same repository to facilitate research and use. As appropriate, lend these collections for exhibit, research, conservation, and other approved uses. Superintendents may authorize housing of collections from the same accession at different repositories if by so doing preservation, research, and use will be improved.

4.3.18 Collections Management Report: Annually complete the automated Collections Management Report (CMR), using ANCS+. The report provides information on accessions, deaccessions, cataloging, backlogs of objects to be cataloged, use of museum collections, and total collection size. The report must include all collections, whether kept in park facilities, other NPS facilities, or in non-NPS repositories. Submit the CMR using ANCS+.

4.3.19 Annual Inventory: Conduct an annual collection inventory on a regular schedule using the Automated Inventory Program (AIP) in ANCS+ and reconcile the results with existing accession and catalog records. Take any necessary corrective action.

4.3.20 Checklist: Keep the NPS Checklist for Preservation and Protection of Museum Collections (Checklist) up-to-date in the Automated Checklist Program (ACP) in ANCS+. The Checklist records information on preservation and protection conditions in parks and centers, identifies deficiencies, and provides estimated costs to correct deficiencies.

4.3.21 Treatment Documentation: Document treatment of collections, and record that information in ANCS+ and retain reports and documentation in accession or catalog files.

4.3.22 Cellulose Nitrate and Cellulose Ester Film: Identify cellulose nitrate and cellulose ester film, and take steps to preserve the visual information contained by duplicating the images onto safety film. After inspecting the copies, evaluate and either deaccession and destroy or provide for long-term storage of the original film according to the criteria in *Museum Handbook*, Part I, Appendix M, "Management of Cellulose Nitrate and Ester Film."

4.3.23 Access and Use: Promote access to cataloged collections for research and interpretive purposes through a variety of means and media, such as exhibits, interpretive programs, loans, publications, film and television, the World Wide Web, archival finding aid production and distribution, and posting of finding aids and repository-level guides for archival and manuscript collections in the National Union Catalog of Manuscript Collections (NUCMC).

- Ensure that access and use are consistent with the laws and NPS policies pertaining to Freedom of Information Act disclosures, copyright, privacy, publicity, obscenity and pornography, defamation, and resource protection.
- Document access and use with a researcher logbook, signed access policy statement, researcher registration, copyright and privacy restriction statement, and duplication forms.

4.3.24 Consultation: Consult with affiliated groups in managing collections, including Native American groups when managing collections subject to the Native American Graves Protection and Repatriation Act.

4.3.25 Preservation vs. Destructive Use: Manage objects to preserve their condition, including using reproductions when originals may be damaged by use. Authorize in writing destructive analysis of collections, except for rare or highly significant objects, specimens, and archival materials. Obtain regional director approval for destructive analysis of rare or highly significant objects, specimens, and archival materials and for any consumptive use of collections.

4.3.26 Exhibits: Exhibit collections according to an approved exhibit plan, accompanied by maintenance instructions. Ensure that all exhibits meet the standards in the NPS Checklist for Preservation and Protection of Museum Collections.

4.3.27 Objects in Historic Structures: Document furnishings that are exhibited in their associated historic structures with an approved Historic Furnishings Report. Consider the preservation requirements of both objects and historic structures when objects are on exhibit or in storage in historic structures.

4.3.28 Exhibit of Human Remains: Never exhibit Native American human remains or photographs, drawings or renderings, or casts of the remains. Exhibit non-Native-American human remains and photographs, drawings or renderings, or casts of the remains only in consultation with traditionally associated groups.

4.3.29 CRBIB: Ensure that approved museum plans are entered in the Cultural Resource Management Bibliography (CRBIB).

5. Submissions and Deadlines

5.1 Collections Management Report: Parks and centers will submit the CMR for the previous fiscal year by **November 1** simultaneously to the Regional Director, Attention: Regional Curator, and to the Museum Management Program (MMP), National Center for Cultural Resources. The MMP will prepare this information for the strategic planning and annual reporting processes and compile and distribute cluster, regional, and Service-wide reports.

Parks and MMP use CMR data to report on Strategic Plan Goal Ia6 in compliance with the Government Performance and Results Act.

5.2 Checklist: Parks and centers will update their Checklist in the ACP by **November 1** to show changes as of the end of the previous fiscal year. Parks and centers will submit their Checklist data using the ACP simultaneously to the Regional Director, Attention: Regional Curator, and to the MMP. The MMP will compile and distribute cluster, regional, and Service-wide reports.

Parks and MMP use Checklist data to report on Strategic Plan Goal Ib2D in compliance with the Government Performance and Results Act.

5.3 Annual Inventory: Parks and centers will annually submit the inventory generated using the AIP to the regional director, according to a schedule that the region approves. The regional director will certify the completion of the inventories to the Associate Director, Cultural Resource Stewardship and Partnerships, Attention: Chief Curator, no later than **September 30** each fiscal year.

5.4 National Catalog Submissions: Parks and centers will annually submit to the National Catalog complete electronic backups of their ANCS+ accession and catalog records, identifying new or modified records. The submission for the previous fiscal year is due in **November, December, or January**, according to the schedule established in the *Museum Handbook*, Part II. The National Catalog will print and store archival paper copies of the catalog records. The National Catalog will print and send paper copies of catalog records to parks and centers upon request.

--- End of Director's Order ---

Appendix B: Accreditation

A. Overview	B:1
What is museum accreditation?.....	B:1
What institutions are eligible to apply?.....	B:1
Why should a park museum apply for accreditation?	B:1
What does accreditation involve?	B:2
How long will accreditation take?	B:2
How much will accreditation cost the park?.....	B:3
What funds are available for accreditation?	B:3
Where can I get an application and further information?.....	B:3
B. Accreditation Step-by-Step	B:4
Step 1: Consultation	B:4
Step 2: Regional Director Approval.....	B:4
Step 3: Application	B:4
Step 4: Self-Study	B:4
Step 5: Accreditation Commission Review of Self-Study.....	B:5
Step 6: Selection of Visiting Committee	B:5
Step 7: Scheduling the Visiting Committee Visit.....	B:5
Step 8: Visiting Committee Visits Park.....	B:5
Step 9: Visiting Committee Report.....	B:5
Step 10: Accreditation Commission Review.....	B:5
Step 11: Subsequent Accreditation.....	B:6
List of Figures	
Figure B.1 Attachments Required for Self Study: AAM Documents and NPS Equivalents.....	B:7

APPENDIX B: ACCREDITATION

A. Overview

1. *What is museum accreditation?*

In the United States, the American Association of Museums (AAM) operates a museum accreditation program. The program assesses how well a museum meets current professional standards. The assessment process involves self-study by the museum as well as peer review. The AAM Accreditation Commission, composed of appointed members of the museum community, grants accreditation status to museums that meet the generally accepted standards. The Commission reviews an accredited museum's status every five to ten years.

2. *What institutions are eligible to apply?*

Applicants must meet eligibility criteria and demonstrate the characteristics of an accreditable museum as published by the AAM. Application information is on the AAM Web site at <http://www.aam-us.org/museumresources/accred/apply.cfm>. See Section A.8 for additional information.

Park museums that have been open for at least two years, have public exhibits, and are operating according to NPS policies and procedures are likely to meet the AAM accreditation eligibility criteria.

In addition, NPS requires that parks meet the following requirements before applying for accreditation:

- All collections are accessioned.
- All collections are cataloged *or* the park has an approved action plan that addresses cataloging of the backlog (park-approved Project Management Information System [PMIS] Project Statement for backlog cataloging).
- Collections are adequately stored, secured, and protected by fire detection and suppression systems, *or* the park has approved program management plans (such as the park resource stewardship strategy and the Collection Management Plan) that address the correction of deficiencies identified on the NPS Checklist for Preservation and Protection of Museum Collections (Museum Checklist).
- An approved Scope of Collection Statement is in effect.
- Exhibits are relevant to the park mission and adequately maintained.

3. *Why should a park museum apply for accreditation?*

Accreditation provides review and recognition of the park's museum programs and operations by the museum profession. It offers the benefits of ongoing critical self-evaluation and peer review. Accreditation gains public recognition, which attracts volunteers and visitors. It also facilitates loans, traveling exhibitions, and fundraising to support park museum operations.

4. *What does accreditation involve?*

The accreditation process involves the following steps:

- Park reviews information about accreditation, including tips for preparedness, tools for determining readiness, and eligibility criteria, on the AAM Web site.
- Park consults with regional curator about accreditation.
- Park requests approval to apply and Regional Director grants approval or identifies improvements needed.
- Park completes and submits the application form. When the application is accepted, the AAM will bill the park for the application fee of \$400. The park should pay this fee with the charge card.
- Park completes self-study.
- AAM Accreditation Commission reviews self-study and grants interim approval, tables interim approval pending submission of clarifying information or correction of deficiencies within six to twelve months, or denies interim approval. Interim approval is necessary to continue in the accreditation process.
- Park reviews list of potential Visiting Committee members that AAM provides, noting any conflicts of interest.
- AAM selects the Visiting Committee Team Contact who then selects a second team member and schedules the visit directly with the park superintendent.
- Visiting Committee visits park.
- Visiting Committee submits report to AAM Accreditation Commission.
- Accreditation Commission reviews the report and grants accreditation, tables the decision pending correction of identified concerns within one year, denies accreditation, or defers a decision pending submission of additional clarifying information.
- AAM initiates mandatory subsequent review of accreditation within ten years (or within five years if the museum was identified for early subsequent review at the time of accreditation).

See Section B for step-by-step procedures in the accreditation process.

5. *How long will accreditation take?*

Generally, the initial accreditation process requires 31-43 months and the subsequent review takes 27-38 months. The process varies for each museum depending on such factors as the:

- time the park takes to prepare the documents

- scheduling of Accreditation Commission reviews and follow-up actions if tabling, denials, or deferrals are involved
- time required to schedule the Visiting Committee

See the “Quick Reference Guide to the Accreditation Review Process” on the AAM Web site.

6. *How much will accreditation cost the park?*

The accreditation process represents a significant commitment of park staff time. In addition, the park pays accreditation fees and travel expenses.

AAM bills the park for accreditation fees and the park uses the charge card to pay:

- a non-refundable one-time application fee billed following acceptance of the application (\$400; subject to change). This fee is not required for subsequent reviews.
- an annual participation fee billed each January for accredited museums and applicants (\$200 for members; \$500 for non-members; both subject to change).

For the Visiting Committee’s travel expenses, the park must issue a purchase order to the AAM in advance of the visit for the Visiting Committee’s services. The cost estimate should be based on the anticipated travel expenses of the Visiting Committee. Following the visit, the AAM will bill the park for the Visiting Committee’s costs.

7. *What funds are available for accreditation?*

Parks may use appropriated funds and donated funds, including cooperating association funds, to pay accreditation fees.

8. *Where can I get an application and further information?*

Complete information on the Accreditation Program, a downloadable application form, and information on ordering an Accreditation Resource Kit are on the AAM Web site at <http://www.aam-us.org/museumresources/accred/apply.cfm>.

The Accreditation Resource Kit includes the following publications:

- *A Higher Standard: The Museum Accreditation Handbook*. This publication is the definitive guide to the accreditation process and a preview of what is expected of an accredited institution.
- *The Accreditation Self-Study Guide*. This booklet provides a framework for the institution to conduct a self-evaluation of its operations and for application to the accreditation program.
- *The Accreditation Self-Study Guide on CD-ROM*

You may also order the Accreditation Resource Kit from the AAM

Bookstore by mail, telephone, or via the online catalog:

AAM Bookstore
1575 Eye Street, NW, Suite 400
Washington, DC 20005
(202) 289-9127
E-mail: bookstore@aam-us.org
<http://www.aam-us.org/bookstore/index.cfm>

AAM Accreditation Program
1575 Eye St. N.W., Suite 400
Washington, DC 20005
(202) 289-9116
E-mail: accreditation@aam-us.org

If you are interested in gaining accreditation for the park museum, be sure to consult the regional curator as far in advance as possible. The region may have additional guidelines and procedures for the park to follow. Also, the regional curator can provide helpful information, insight, and support throughout the process.

B. Accreditation Step-by-Step

Step 1: Consultation

Consult with the regional curator about the park's readiness to apply for accreditation. Confirm that the park meets AAM and NPS eligibility criteria. See Section A.2. If the park doesn't meet the eligibility criteria, correct the deficiencies and repeat Step 1.

Note: During the application or accreditation process the park, regional office, or the Accreditation Commission may identify deficiencies that the park needs to correct before going to the next step.

Step 2: Regional Director Approval

Request Regional Director approval to apply for accreditation. The Regional Director, upon the recommendation of the regional curator, grants approval for the park to apply for accreditation, or identifies deficiencies that the park needs to correct.

Step 3: Application

Study information on the AAM Web site at <http://www.aam-us.org/museumresources/accred/index.cfm>. Download and complete the application. Consult the regional curator and submit the application to the AAM. Pay the application fee when the AAM bills the park. See Section A.6.

Step 4: Self-Study

The AAM sends the Accreditation Self-Study Questionnaire to the park. Complete the self-study in consultation with the regional curator. Submit the self-study and supporting documents to the AAM within one year of the application. Use Figure B.1, “Attachments Required for Self-Study: AAM Documents and NPS Equivalents,” to select supporting documents for submission with the questionnaire.

Step 5: Accreditation Commission Review of Self-Study (first-time applicants only)

The Accreditation Commission reviews the self-study and takes one of the following actions:

- Grants interim approval: the park may proceed to the next step.
- Denies interim approval: the park must withdraw its application but may reapply in the future.
- Tables the decision: the park must provide further information or clarification within six to twelve months. Upon reviewing the additional information, the Accreditation Commission will grant interim approval or deny accreditation.

Step 6: Selection of Visiting Committee

The AAM will send the park a roster of potential Visiting Committee members. Work with the regional curator to identify any conflicts of interest and return the list by the due date (generally one month). AAM selects the Visiting Committee team contact who then selects a second team member.

Step 7: Scheduling the Visiting Committee Visit

The team contact works with the park superintendent to schedule the Visiting Committee’s visit. The park issues a purchase order to AAM to cover the travel expenses of the Visiting Committee. See Section A.6.

Step 8: Visiting Committee Visits Park

The Visiting Committee visits the park. AAM bills the park to cover the committee’s travel expenses.

Step 9: Visiting Committee Report

The Visiting Committee submits its report to the AAM Accreditation Commission within four weeks of the visit.

Step 10: Accreditation Commission Review

The Accreditation Commission reviews the self-study and the report and takes one of the following actions:

- Grants accreditation (usually for ten years, but may be granted for only five years if the Commission has concerns)
- Denies the award
- Tables its decision for specific concerns or deficiencies to be addressed within one year
- Defers a decision if additional information is needed

The Accreditation Commission Chair sends a written notification to the park superintendent stating the decision and providing a copy of the Visiting Committee's report. The AAM separately returns the self-study materials to the park. If the park museum is accredited, the notification states the date to initiate subsequent accreditation.

Step 11: Subsequent Accreditation

On a cycle of ten (or five) years, as specified at the time of accreditation, the AAM notifies the park of the need to review the park's accredited status. This review involves Steps 4-10. (The Accreditation Commission reviews the self-study only in Step 10.) This process is called subsequent accreditation.

Attachments Required for Self-Study: AAM Documents and NPS Equivalents	
Required AAM Documents	NPS Equivalents
Note: See links to document descriptions at http://www.aam-us.org/museumresources/accred/document-list.cfm	Note: For documents on the Web, provide the URL rather than hardcopy when submitting attachments for the Self-Study.
Institutional code of ethics	NPS <i>Museum Handbook</i> , Part I, Appendix D, Code of Ethics for NPS Museums (2006) at http://www.cr.nps.gov/museum/publications/index.htm .
Mission statement	NPS Mission Statement at http://www.nps.gov/legacy/mission.html . Park mission statement (Foundation Statement) is in the park's General Management Plan and in the park's strategic plan posted on the park Web site.
Institutional plan	Strategic plans show goals and accomplishments—see Park Strategic Plan available on park Web site, NPS Strategic Plan at http://www.nps.gov/refdesk/policies.html , Department of the Interior Strategic Plan at http://www.doi.gov/gpra/ (see Resource Protection Goal 3). Provide the park's Annual Performance Plan based on GPRA goals and performance using data from the Performance Management Data System at http://www.nps.gov/performance/ . If the Annual Performance Plan is on the park's Web site, provide the URL. As needed, ask the park Government Performance and Results Act (GPRA) coordinator to assist. Park's General Management Plan
Articles of incorporation, charter, or enabling legislation	NPS Organic Act (1916) (16 USC 1) at http://www4.law.cornell.edu/uscode/html/uscode16/usc_sup_01_16_10_1.html . Park's enabling legislation.
Bylaws, constitution, or will	NPS <i>Management Policies</i> at http://www.nps.gov/refdesk/mp/index.html .
IRS letter of notification regarding tax-exempt status	Not applicable to US Government.

**Figure B. 1. Attachments Required for Self-Study:
AAM Documents and NPS Equivalents**

Required AAM Documents	NPS Equivalents
<p>If the museum has a parent organization: Documentation regarding the importance of the museum to the parent, expressing its commitment to support the museum (e.g., resolution of permanence passed by parent, parent organization's by-laws or organizing documents, memorandum of understanding, or management agreement between the parent and the museum)</p>	<p>Park's enabling legislation.</p> <p>The following are optional references that may be submitted:</p> <p>NPS Organic Act (1916) (16 USC 1) at http://www4.law.cornell.edu/uscode/html/uscode16/usc_sup_01_16_10_1.html.</p> <p>Museum Act (1955) (16 USC 18f–18f-3) at http://www.cr.nps.gov/museum/laws/lawregad.html.</p> <p>NPS <i>Management Policies</i> at http://www.nps.gov/refdesk/mp/index.html</p>
<p>Documentation of operational relationships with other organizations integrally connected to the museum's governance or operations (e.g., written memorandum of understanding or other type of formal agreement)</p>	<p><i>Management Policies</i>, Chapter 7, section 7.6.2, Cooperating Associations, and Chapter 10, section 10.2, Concessions, at http://www.nps.gov/refdesk/mp/index.html.</p> <p>Cooperating Association Agreement.</p> <p>Concessions Contract.</p>
<p>List of current members of the governing authority</p>	<p>Secretary of the Interior; Director, National Park Service; Regional Director.</p>
<p>Evidence of delegation of authority for day-to-day operation of the museum to the museum director or the equivalent position</p>	<p>Department of the Interior, Departmental Manual, Part 145, National Park Service, Chapter 2, Basic Organization, showing delegation of authority from Director to park superintendent at http://elips.doi.gov/app_dm/act_getfiles.cfm?relnum=3642. Park superintendent is equivalent to the museum director.</p>
<p>Table of contents of the governance manual (i.e., reference manual assembled for use by members of the governing authority to assist with orientation, training, and ongoing work)</p>	<p>Table of Contents of Department of the Interior Departmental Manual available at http://elips.doi.gov/app_dm/index.cfm?fuseaction=home.</p> <p>National Park Service <i>Management Policies</i> and Director's Orders available at http://data2.itc.nps.gov/npspolicy/index.cfm.</p>
<p>Organizational chart(s) (including parent organization, governing authority, partner organization, advisory board, supporting organizations, staff, and volunteers as applicable)</p>	<p>NPS organization chart available at http://elips.doi.gov/app_dm/act_getfiles.cfm?relnum=3642.</p> <p>Park organization chart.</p>

Figure B. 1. Attachments Required for Self-Study: AAM Documents and NPS Equivalents (continued)

Required AAM Documents	NPS Equivalents
List of principal professional and administrative staff positions (including the following for each: title, incumbent's name, salary, and employment category)	Park staff list for all supervisors showing title, name, salary, job classification series.
Position descriptions and current resumes for principal professional and administrative staff (both current and vacant positions)	Position descriptions and personal resumes for key positions in chain of command with oversight for museum operations, including superintendent.
List summarizing staffing levels (numbers) by category (e.g., administrative, curatorial, education, security, physical plant, visitor services, etc.)	Same
Personnel policies manual	Department of the Interior, Office of Human Resources, policy guidance at http://www.doi.gov/hrm/guidance/curronly.htm
Repository agreement for objects in custody without title (required for some museums)	Repository Agreement and/or incoming loan agreement if park manages collections for a non-NPS entity.
Visual images to illustrate the scope of the museum's collections	If available, provide URLs for images of the park's collection on the park's Web site, in the Web Catalog at http://www.museum.nps.gov/ , or on the Museum Management Program Web site at http://www.cr.nps.gov/museum/ . Otherwise, provide a CD of images illustrating the scope of the museum's collections (no more than 20-30 images). If possible, combine all image requirements from this chart on a single CD.
Collections management policy and loan policies (custodial care and borrowing policies for museums that do not own or manage collections, but borrow and use collections for exhibits, education, or research)	Director's Order #24, NPS Museum Collections Management at http://www.nps.gov/policy/DOrders/DOrder24.html . <i>NPS Museum Handbook</i> , Parts I-III; <i>Automated National Catalog System User Manual</i> ; and <i>Conserve O Gram</i> at http://www.cr.nps.gov/museum/publications/index.htm .
Sample copy of completed collections documentation record(s) (with accession, catalog, and inventory information)	Copies of the following records with information completed: a Catalog Record (10-254) and an All Fields Report for each of the major disciplines represented in the park's collection (archeology, ethnology, history, archives, biology, geology, paleontology); an Accession Receiving Report (10-95); an Accession Folder Cover Sheet (10-255); a Deed of Gift (10-830); a Receipt for Property (DI-105); the most recently completed annual inventory forms (10-349).

Figure B. 1. Attachments Required for Self-Study:

AAM Documents and NPS Equivalentents (continued)

Required AAM Documents	NPS Equivalents
If the museum is authorized to deaccession, a copy of a deaccession form or other written documentation used for deaccessioning purposes (a completed form if applicable, otherwise a blank form)	Copy of completed Deaccession Form (10-643).
Sample copy of a completed outgoing loan agreement	Copy of completed Outgoing Loan Agreement (10-127) with Conditions (10-127a).
Sample copy of a completed incoming loan agreement	Copy of completed Incoming Loan Agreement (10-98) with Conditions (10-98a).
Sample copy of completed condition report form	Copy of completed Condition Report (10-637)
List of titles and dates of the museum's exhibit offerings during the last three years (long-term, temporary, traveling exhibits)	List of long-term, traveling, and temporary exhibits that the park has shown in last three years. Give titles, dates, and locations for exhibits.
Images of exhibits to illustrate various exhibition design techniques used (in galleries, other interiors, interpreted landscapes, other exterior settings)	Provide images of exhibits, historic structures, interiors of furnished historic structures, park features, and landscapes to illustrate exhibit design and visitor-presentation techniques. Include wayside exhibits. Exhibit producers (Harpers Ferry Center or contractors) are good sources of images. If possible, include all image requirements from this chart on a single CD.
Images that illustrate the museum's live interpretive activities in action (e.g., programs, outreach, demonstrations, tours, interpreters, classes, etc.)	Images of the park's interpretive programs (personal services). Contact the park's Chief Interpreter. If possible, combine all image requirements from this chart on a single CD.
List of museum publications and non-print media projects (print, audio, electronic) produced in the past three years (list name, format, and date)	Work with the Chief Interpreter and Chief of Resources Management to identify relevant NPS and cooperating association publications and non-print media projects, such as films, slide shows, postcards, and CDs produced in last three years. List name, media format, and date.
If the museum does original research: List of staff research results published in publications (e.g., books, popular or scholarly journals) other than the museum's in the last three years	Work with the Chief of Resources Management to identify published research results for the last three years. Contact the Inventory and Monitoring Network and the region's Archeological Center for publications relevant to the park.

**Figure B. 1. Attachments Required for Self-Study:
AAM Documents and NPS Equivalents (continued)**

Required AAM Documents	NPS Equivalents
Most recent museum program/exhibit/events calendar	Coordinate with the Public Affairs Officer and Chief of Interpretation for the most recent park events calendar.
Samples of: promotional materials (e.g. program announcements, exhibit brochures, etc.) that illustrate the scope of the museum's interpretive offerings; materials that illustrate the range of programs for students and teachers; museum publications and/or non-print media materials (Four maximum for each category)	Same
Current year operating budget and non-operating expenditures	Provide a copy of the park's current financial plan and information on any construction program activities or other non-operating expenditures.
Audited financial statements for two years plus management letters (if most recent year is not yet available, submit unaudited year-end financial report)	<p>NPS Performance and Accountability Reports are posted at http://www.doi.gov/pfm/burrept.html. The independent auditors' report is at the back of each year's report.</p> <p>Cross-reference the park's Annual Performance Plan provided above. Provide the park's Annual Performance Report based on GPRA goals and data from the Performance Management Data System at http://www.nps.gov/performance/. If this document is on the park's Web site, provide the URL.</p>
Floor plan and/or site map	Official park brochure, plus other site maps and museum floor plans, if available.
Emergency/disaster preparedness plan (covering staff, visitors, and collections)	Park Emergency Operations Plan including the Museum Collections Emergency Operations Plan component (see <i>Management Policies</i> 8.2.5.2 and Director's Order #24, 4.3.10).
Images of the museum's public and non-public areas, both indoors and outside (e.g.: grounds, exteriors, galleries/exhibit spaces, classrooms/studios/programming spaces, sales areas, food service areas, collections processing/storage, mechanical areas, laboratories, offices, workshops, loading dock/receiving area, etc.)	Same. Provide a CD with these images. If possible, combine all image requirements from this chart on a single CD.

**Figure B. 1. Attachments Required for Self-Study:
AAM Documents and NPS Equivalents (continued)**

AAM Documents, If Available	NPS Equivalents, If Available
<p>Samples of tools the museum uses to assess whether it has achieved its goals (e.g., visitor satisfaction surveys, exhibition evaluations, program evaluations, focus group questions/reports, community surveys, financial/other performance indicators, etc.)</p>	<p>Strategic plans show goals and accomplishments, see Park Strategic Plan available on park Web site, NPS Strategic Plan at http://www.nps.gov/refdesk/policies.html, Department of the Interior Strategic Plan at http://www.doi.gov/gpra/ (see Resource Protection Goal 3).</p> <p>Recent results for Visitor Survey Card (park reports posted at http://www.psu.uidaho.edu/vsc.schedule.htm, see http://www.psu.uidaho.edu/ for additional information).</p> <p>Office of Management and Budget NPS Visitor Services Assessment at http://www.whitehouse.gov/omb/expectmore/detail.10003723.2005.html.</p> <p>Other park-specific surveys.</p>
<p>Vision/value statement(s)</p>	<p>Same</p>
<p>Documentation regarding any internal, non-governing groups that serve in an advisory capacity (e.g., resolution of the board establishing this group, statement of purpose, operating guidelines, etc.)</p>	<p>General information on NPS advisory and operating committees at http://www.nps.gov/policy/advisory/boardscomms.htm.</p> <p>National Park System Advisory Board documentation at http://www.nps.gov/policy/advisory/advboard.htm.</p> <p>Park-specific information, as applicable.</p>
<p>Table of contents of volunteer manual</p>	<p>Director's Order #7, Volunteers in Parks at http://www.nps.gov/policy/DOrders/DO-7.htm.</p>
<p>Collections plan</p>	<p>Park's Collection Management Plan; Scope of Collections Statement.</p>
<p>Conservation plan</p>	<p>Park's Collection Management Plan and Collection Condition Survey.</p>
<p>Interpretive plan or education master plan</p>	<p>Park's Comprehensive Interpretive Plan.</p>
<p>Furnishing plan</p>	<p>Park's Historic Furnishings Report, as applicable.</p>
<p>Investment policy</p>	<p>Not applicable to US Government.</p>
<p>Annual reports produced within the last three years</p>	<p>Cross-reference the park's Annual Performance Plan and Annual Performance Report provided above.</p>

**Figure B. 1. Attachments Required for Self-Study:
AAM Documents and NPS Equivalents (continued)**

AAM Documents, If Available	NPS Equivalents, If Available
Printed descriptive materials pertaining to any membership/donor programs (should include dues and benefits structure for each program)	Information on National Park Foundation at http://www.nationalparks.org/Home.asp .
Individual donor support policy	Director's Order #21, Donations and Fundraising, http://data2.itc.nps.gov/nspolicy/DOrders.cfm .
Business support policy	Director's Order #21, Donations and Fundraising, http://data2.itc.nps.gov/nspolicy/DOrders.cfm .
Completed RC-AAM Standard Facility Report	Completed NPS Checklist for Preservation and Protection of Museum Collections (from Automated Checklist Program in ANCS+).

Note: A complete Accreditation Self-Study consists of a detailed questionnaire plus the attachments. The Self-Study Questionnaire is not available on the AAM Web site. Accreditation Program participants can get a copy by calling 202-289-9116 or e-mailing accreditation@aam-us.org. The questionnaire is available to others by purchasing the Accreditation Resource Kit from the AAM Bookstore.

**Figure B. 1. Attachments Required for Self-Study:
AAM Documents and NPS Equivalents (continued)**

Appendix C: Professional Organizations and Societies

	Page
A. Overview	C:1
B. National Museum Organizations	C:1
C. Regional Museum Conferences and Associations	C:3
D. Regional Conservation Guilds and Associations	C:4
E. Museum Journals and Technical Publications.....	C:5
F. Funding Organizations	C:6

APPENDIX C: PROFESSIONAL ORGANIZATIONS AND SOCIETIES

A. Overview

There are several organizations and societies that are involved in various aspects of museum work. This appendix provides a list of the major organizations and societies that provide professional guidance to individuals and institutions in the functions of museum and archival work.

B. National Museum Organizations

- *The American Association of Museums (AAM)*, founded in 1906, addresses the concerns of the country's museum community as a whole and represents art and natural history museums, zoos, botanical gardens, arboretums, planetariums, science and technology centers, nature centers, children's museums, and historic museums, sites, and societies. Members include museum directors, curators, registrars, educators, marketing and development directors, public relations personnel, and others. The AAM's Accreditation Program (refer to Appendix B) has long been a leader in establishing professional standards for museums and museum professionals. Publications include a bi-monthly journal, *Museum News*, and a monthly newsletter *Aviso*. The AAM bookstore stocks publications that address such topics as collections management, museum ethics, conservation, marketing, and fund raising. The association holds an annual meeting. Write, call, or visit the AAM Website for information on membership, publications, and other programs.

American Association of Museums
1575 Eye Street, NW, Suite 400
Washington, DC 20005

Tel: (202) 289-1818
<<http://www.aam-us.org>>

- *The American Association for State and Local History (AASLH)* is a national non-profit organization that serves agencies and people who work to preserve and interpret history, including historical societies, museums, historic sites, parks, libraries, archives, historic preservation organizations, and schools and colleges. The association has adopted and published the "AASLH Statement of Professional Ethics." Publications include a quarterly magazine, *History News*, and a monthly newsletter, *Dispatch*. The association's sales program provides publications and educational materials (e.g., books, technical leaflets, reports, and video programs) on the documentation, preservation, and interpretation of

history, including the care and conservation of museum objects.

The association sponsors seminars, workshops, and an annual meeting. Write, call, or visit the AASLH Website for information on membership, publications, and other programs.

American Association for State
and Local History
1717 Church Street
Nashville, TN 37203

Tel: (615) 320-3203
<<http://www.aaslh.org>>

- ***The American Institute for Conservation of Historic and Artistic Works (AIC)*** addresses the concerns of the conservation profession. Members include conservators who practice in all of the material specialties (e.g., paintings, books and paper, textiles, wood, photographic materials, and objects of leather, ceramic, glass, and stone) and conservation scientists. Librarians, archivists, and curators may also be members. This organization has adopted and published the “AIC Code of Ethics and Guidelines for Practice” for the conservation profession in the United States (refer to Appendix D). Publications include the *Journal of the American Institute for Conservation* (published three times a year) and the bimonthly newsletter, *AIC News*. The newsletter includes information from the various specialties, health and safety updates, preventive conservation information, and a list of conferences, courses, and seminars. The association sponsors an annual meeting, including a pre-meeting workshop. The association also publishes an annual directory of its membership. Write, call, or visit the association’s Website for membership or other information.

American Institute for Conservation
of Historic and Artistic Works
1717 K Street, NW, Suite 200
Washington, DC 20006

Tel: (202) 452-9545
<<http://aic.stanford.edu>>

- ***The Society of American Archivists (SAA)***, founded in 1936, promotes the preservation and use of records materials (e.g., manuscripts, films, maps, photographs, sound recordings, and machine-readable records). This organization provides a wide range of educational workshops, maintains an active publications program, and promotes cooperation, growth, and development in the archival field. The society has adopted and published “A Code of Ethics for Archivists with Commentary.” Publications include a semi-annual journal, *American Archivist*, and a bimonthly newsletter, *Archival Outlook*. The SAA’s publication program offers basic manuals on the arrangement, description, access, conservation and care, and exhibition of archival collections. The society sponsors an annual meeting. Write, call, or visit the SAA

Website for information on membership, publications, and other programs.

Society of American Archivists
527 South Wells Street, 5th Floor
Chicago, IL 60607

Tel: (312) 922-0140
<<http://www.archivists.org>>

- ***The Society for the Preservation of Natural History Collections (SPNHC)*** represents the interests of natural history collections and the people associated with the management and care of these collections. Membership includes individuals from the fields of anthropology, botany, geology, paleontology, and zoology and others interested in the development and preservation of natural history collections. Publications include a journal, *Collection Forum*, a newsletter, *SPNHC Newsletter*, and the “Guidelines for Care of Natural History Collections.” The journal, published twice a year, provides up-to-date technical and documentary information on the care of natural history collections. The society conducts annual meetings that include formal presentations and workshops. Write, call, or visit the SPNHC Website for membership information.

Society for the Preservation
of Natural History Collections
PO Box 797
Washington, DC 20044

Tel: (202) 786-2426
<<http://www.spnhc.org>>

C. Regional Museum Conferences and Associations

- Association of Midwest Museums
PO Box 11940
St. Louis, MO 63112

Tel: (314) 454-3110
<<http://www.midwestmuseums.org>>
- Mid-Atlantic Association of Museums
PO Box 27151
Baltimore, MD 21230

Tel: (410) 223-1194
<<http://www.midatlanticmuseums.org>>

- Mountain Plains Museum Association
PO Box 8321
Durango, CO 81301

Tel: (970) 259-7866
<<http://www.frontier.net/~mpma/mpmainindex.htm>>
- New England Museum Association
Boston National Historical Park
Charlestown Navy Yard
Boston, MA 02129

Tel: (617) 242-2283
<<http://www.nemanet.org>>
- Southeastern Museums Conference
PO Box 3494
Baton Rouge, LA 70821

Tel: (225) 383-5042
<<http://www.semcdirect.net>>
- Western Museums Association
PO Box 13314
Suite 578
Oakland, CA 94661

Tel: (510) 428-1380
<<http://www.westmuse.org>>

For a list of other regional, state, national, and international museum organizations, contact the American Association of Museums (AAM), or visit the AAM Website at <<http://www.aam-us.org>>.

D. Regional Conservation Guilds and Associations

There are several regional conservation associations located throughout the country. These groups usually hold monthly meetings that address special topics in conservation including museum environment and other preventive conservation issues. Contact the regional/SO curator or write to or call the American Institute for Conservation for a current list of the names and addresses of these regional associations.

E. Museum Journals and Technical Publications

- ***ASC Newsletter***

This bimonthly publication is available by subscription from the Association of Systematics Collections (ASC). The newsletter contains articles on systematic natural history collections, as well as brief notes on funding sources, meetings and conferences, and book reviews. For information on subscribing to this newsletter, write or call:

Association for Systematics Collections
1725 K Street, NW
Suite 601
Washington, DC 20006

Tel: (202) 835-9050
<<http://www.ascoll.org>>

- ***Curator: The Museum Journal***

This journal, published quarterly by the California Academy of Sciences and Altamira Press, is available by annual subscription. *Curator* provides timely articles on philosophical issues concerning the museum profession, documentation, and care of museum collections, and specific articles on solving storage and exhibit problems. For subscription information write to:

Curator: The Museum Journal
15200 NBN Way
Blue Ridge Summit, PA 17214

Tel: (717) 794-3800 ext. 3154

- ***Canadian Conservation Institute (CCI/ICC) Notes and Newsletter***

The Canadian Conservation Institute (CCI) publishes a series of technical notes, *CCI Notes* (similar to NPS Conserve O Grams), on museum collections care topics (e.g., the museum environment; disaster management; equipment; and techniques of caring for specific types of objects, including paintings, leather, skin, ethnographic materials, textiles, photographic materials). In addition to *CCI Notes*, the institute also publishes the semiannual *CCI Newsletter*, periodic *Technical Bulletins*, books, and other publications. For additional information contact CCI at:

Canadian Conservation Institute
1030 Innes Road
Ottawa, Ontario K1A 0M5
Canada

Tel: (613) 998-3721
<<http://www.cci-icc.gc.ca>>

F. Funding Organizations

In addition to National Park Service funding programs, parks can apply for other funding to support museum programs. The park's cooperating association may apply for federal funding for a museum collections project on behalf of a park. Parks may also apply to foundations, charitable organizations, and other outside organizations for museum funding. Consult with the regional/SO curator.

Parks can contact the following organizations for further information on the types of grants available:

Federal Programs

- Institute of Museum and Library Services
Office of Museum Services
1100 Pennsylvania Avenue, NW
Suite 609
Washington, DC 20506

Tel: (202) 606-8536
<<http://www.imls.gov>>

- National Endowment for the Arts
1100 Pennsylvania Avenue, NW
Washington, DC 20506

Tel: (202) 682-5400
<<http://www.nea.gov>>

- National Endowment for the Humanities
1100 Pennsylvania Avenue, NW
Washington, DC 20506

Tel: (202) 606-8400
<<http://www.neh.gov>>

Non-Governmental Programs

- ***The Foundation Directory***, published by the Foundation Center, lists foundations that provide grants to museums. For a copy of this directory, write to the following address:

The Foundation Center
79 Fifth Avenue
New York, NY 10003

Tel: (212) 620-4230
<<http://www.fdncenter.org>>

Appendix D: CODE OF ETHICS FOR NPS MUSEUMS

A. Overview	D:1
What information will I find in this appendix?.....	D:1
What is ethics in the museum context?	D:1
What is a code of ethics?	D:1
What is a code of ethics for museums?.....	D:1
Does the museum profession have a single code of ethics?.....	D:1
How does a code of ethics relate to law?	D:1
B. Federal Standards of Ethical Conduct Applicable to NPS Museums	D:2
What codes of ethics apply to all NPS employees with responsibility for museum collections?	D:2
What does the Ethics Guide for Employees of the Department of Interior cover?	D:2
Where can I find additional information on ethics for NPS employees?	D:3
C. Code of Ethics for NPS Museums	D:3
What is the Code of Ethics for NPS Museums?	D:3
How do NPS policies relate to the Code of Ethics for NPS Museums?.....	D:3
Who follows the Code of Ethics for NPS Museums?	D:3
What ethics principles do I follow if I am responsible for governance and administration of NPS museums?	D:3
What ethics principles do I follow if I am responsible for the direct management of collections?.....	D:6
What ethics principles do I follow if I am responsible for interpretation or education programs in the park museum or involving the museum collection?....	D:10
What should I do if the Code of Ethics for NPS Museums conflicts with another code of ethics?	D:10
Where can I find assistance in resolving ethics issues specific to the Code of Ethics for NPS Museums?.....	D:11
D. Codes of Ethics for Professional Organizations	D:11

APPENDIX D: CODE OF ETHICS FOR NPS MUSEUMS

A. Overview

1. *What information will I find in this appendix?*

This appendix summarizes Federal standards of ethical conduct applicable to NPS museums and provides a Code of Ethics for NPS Museums in section C. It also references codes of ethics statements from the American Association of Museums (AAM), Society of American Archivists, American Institute for Conservation of Historic and Artistic Works (AIC), and other related professional organizations.
2. *What is ethics in the museum context?*

Ethics is a system of moral principles that governs the behavior of individuals and groups, for example, museum employees individually and as a group in a single or multiple museums. It is about what is right, fair, truthful, honest, beautiful, or, in one word, good. Ethics derives from a general moral consciousness affecting individual and group choices about what is best for the common welfare.
3. *What is a code of ethics?*

A code of ethics is a systematic collection of moral principles that a group believes will benefit the whole. There is agreement in the subscribing group that individual choices must be governed by these principles in order for the individual to contribute to the common good. Codes of ethics may evolve over time, as a group (for example, a society, a community, a profession, or a team) collectively identifies and refines its understanding of what is best for the group.
4. *What is a code of ethics for museums?*

A code of ethics for museums identifies principles that govern the conduct of museum employees and the choices that museums make in order to benefit the societal good. The principles must address the choices made by individuals in the museum organization, as well as groups of individuals, and the museum as a whole.
5. *Does the museum profession have a single code of ethics?*

No. Diverse professional organizations of museum workers, such as archivists, conservators, and curators, as well as individual museums, have different codes of ethics. Professional organizations representing individual disciplines, such as anthropology, history, and paleontology, also have codes of ethics. The AAM has issued a Code of Ethics for Museums that applies exclusively to museums, including botanical gardens, planetariums, and zoos. Museums also subscribe to codes of ethics that apply to specific functions and

disciplines represented in the museum. See Section D for references to codes of ethics for museums and other professional organizations. The AAM requires all accredited museums to have a formally approved, separate and distinct institutional code of ethics.

6. *How does a code of ethics relate to law?*

The law protects specific interests, such as property rights and freedoms, in service to the common good. The law sets a minimum standard. A code of ethics often goes beyond the law in establishing principles for the common good. For example, although bleaching an 18th century quilt so that it is bright white may be legal, doing so would not be consistent with the AIC Code of Ethics and Standards of Practice. Such severe treatment would accelerate the deterioration of the quilt, and diminish the public benefit. The legal rights of individuals may come into conflict with ethics and the common good as well. For example, although a museum curator might legally purchase for his own collection paintings of the same type that the museum has, most museum codes of ethics would consider this a conflict of interest and prohibit or place restrictions on this activity.

B. Federal Standards of Ethical Conduct Applicable to NPS Museums

1. *What codes of ethics apply to all NPS employees with responsibility for museum collections?*

All NPS employees with responsibility for museum collections and functions must follow the:

- Standards of Ethical Conduct for Employees of the Executive Branch (5 CFR 2635)
- Employee Responsibilities and Conduct (43 CFR 20), Department of the Interior
- Supplemental Standards of Ethical Conduct for Employees of the Department of the Interior (5 CFR 3501)
- Criminal Conflict of Interest Statutes (18 USC 201, 203, 205, 207-209)
- Code of Ethics for NPS Museums (see Section C)

2. *What does the Ethics Guide for Employees of the Department of the Interior cover?*

Making Ethics a Part of the Workplace: Ethics Guide for Employees of the Department of the Interior, available at <http://www.inside.nps.gov/waso/custommenu.cfm?lv=3&prg=37&id=3889>, provides plain language guidance to the ethics

laws and regulations that apply to employees of the Department of the Interior (DOI). It addresses actions and responsibilities of the individual employee as follows:

- Basic obligation of public service
- Governmentwide ethics laws
- Department ethics prohibitions
- Accepting gifts
- Traveling for the Department
- Outside work and activities
- Seeking non-Federal employment
- Using Government property, time, and information
- Restrictions that apply after you leave Federal service
- Disclosure of financial interests
- Ethics training and contacts

3. *Where can I find additional information on ethics for NPS employees?*

For all questions concerning ethics, consult your servicing ethics official. Following advice from an ethics official gives an employee a “safe harbor” from disciplinary action. Further information on ethics is in Chapter 9 of *Cultural Resource Management Guideline* (NPS-28, Release No. 5, 1997). In addition, you may want to consult your supervisor, regional curator, or the organizations listed in this appendix. DOI is developing a chapter in the Departmental Manual to address the integrity of scientific activities and a code of scientific conduct.

C. Code of Ethics for NPS Museums

1. *What is the Code of Ethics for NPS Museums?*

The Code of Ethics for NPS Museums is a set of principles that guide the decisions of employees and volunteers who manage or work with NPS museum collections or perform other museum functions. The Code of Ethics was first issued in 1990 in Museum Handbook, Part I (MH-I), Chapter 1. It is reviewed and updated every five years, or more frequently as needed.

2. *How do NPS policies relate to the Code of*

The principles in the Code of Ethics for NPS Museums are

Ethics for NPS Museums?

addressed in all levels of NPS policy. The policy documents include NPS Management Policies, the Director's Order (DO) series, and handbooks. The Code of Ethics for NPS Museums consolidates the ethics information specific to museums.

3. *Who follows the Code of Ethics for NPS Museums?*

The Code of Ethics for NPS Museums applies to NPS employees and volunteers whose actions and decisions directly affect the management of NPS museum collections and/or museum-related functions. It applies to superintendents, managers, museum curators, museum technicians, museum aids, archivists, archives technicians, conservators, housekeepers, maintenance staff, interpreters, park rangers, cultural and natural resource specialists, and all other staff with museum-related functions. It also applies to other staff and volunteers when their jobs interface with museum operations.

4. *What ethics principles do I follow if I am responsible for governance and administration of NPS museums?*

If you are a superintendent, manager, or other employee with administrative responsibility for NPS museums or direct responsibility for museum collections, following NPS Management Policies and Director's Orders you will:

Acquisition, Disposal, and Documentation

- Acquire and dispose of collections consistent with the park's mission and Scope of Collection Statement and in accordance with the Museum Act (16 USC 18f), the Native American Graves Protection and Repatriation Act (25 USC 3001-3013), and NPS policies and procedures.
- Acquire items only if the park can manage them according to NPS policies and standards.
- Acquire items for the museum collections only when you have determined that they have a legal and ethical pedigree. Avoid acquiring, borrowing, and retaining (if previously acquired) any object that has been acquired, exported, or imported contrary to the laws of its country of origin, or any intermediary country, or contrary to the laws and treaties of the United States, including Nazi-era objects that were unlawfully appropriated without subsequent restitution.
- Accept only unconditional gifts for the museum collections, unless the regional director makes exception on a case-by-case basis.
- Avoid conflict of interest and the appearance of conflict of interest when acquiring, borrowing, or disposing of collections and making other decisions affecting collections, including avoiding personal collecting in the same subject area as the museum.
- Follow the prescribed order of preference when deaccessioning,

giving preference to NPS, other DOI bureaus, other Federal agencies, and then non-Federal museums.

See 18 USC 208, Acts Affecting a Personal Financial Interest; 5 CFR 2635.502, Personal and Business Relationships; Management Policies, 5.3.5.5.4 Acquisition, Management and Disposition; DO #24: NPS Museum Collections Management (DO #24), 4.3.2 Standards, 4.3.6 Scope of Collection, 4.3.15 Unconditional Gifts; Cultural Resource Management Guideline, Chapter 9, B.2 Acquisition, B.3 Documentation, and B.7 Deaccessioning; MH-II, Chapter 2 Accessioning, Chapter 6 Deaccessioning.

Preservation and Protection

- Preserve and protect collections while also providing public access.
- Maintain a current Museum Collections Emergency Operations Plan identifying actions required for preparedness and response to protect collections and human health and safety under all risks.
- Authorize conservation treatment consistent with the American Institute for Conservation of Historic and Artistic Works Code of Ethics (AIC)
- Keep information about the security of the museum or of private collections and locations visited during official duties confidential, except to assist law enforcement authorities.

See Management Policies, 5.3.5.5.1 Preservation, 8.2.5.2 Emergency Preparedness and Emergency Operations; DO #24, 4.3.10 Emergency Operation; MH-I, Museum Collections.

Access and Exhibits

- Actively promote appropriate access to collections and data about the collections in order to increase public benefit.
- Ensure that merchandise sold or provided by concessions promotes the park's theme and servicewide mission and values.
- Ensure that concession operations
 - do not sell or offer for sale original objects, artifacts, or specimens of a historic, archeological, paleontological, or biological nature;
 - include with geological merchandise appropriate educational material and a written disclaimer that the items are not from within park boundaries;

- clearly label replicas.

See Management Policies, 10.2.4.5 Merchandise, 10.2.4.6 Artifacts and Specimens; DO #24, 4.3.23 Access and Use; Museum Handbook, Part III (MH-III), Access and Use.

Management

- Ensure that all decisions involving donations to NPS maintain integrity, impartiality, and public confidence as established by the review process in DO#21, Donations and Fundraising (DO #21). Avoid soliciting donations. Avoid accepting donations of money, collections, or services from sources that would contribute to creating a conflict of interest or the appearance of a conflict of interest, including:
 - organizations in which an NPS employee has a leadership role
 - entities that have litigation pending with the Department of Interior, unless that litigation is sufficiently removed so that the donation does not appear to be an attempt to influence the litigation outcome.
 - companies that hold or are seeking concessions contracts or are otherwise engaged in business with the park
 - sources that would identify NPS with alcohol or tobacco products
 - parties that offer donations in order to state or imply the NPS endorsement of a product, service, or entity.
- Authorize fundraising efforts (including marketing relationships with businesses or corporations) to benefit park programs in accordance with DO #21.
- Maintain donation boxes on NPS property only if 100% of the donations go to NPS.
- Avoid naming features or facilities for a donor.
- Provide an annual report on donations.
- Seek and allocate funds sufficient to preserve, document and provide access to the collections and associated documentation.

- Expend funds according to established criteria.

See 5 CFR 2635.201, Gifts from Outside Sources; 5 CFR 2635.502, Personal and Business Relationships; 5 CFR 2635.702, Use of Public Office for Private Gain; 5 CFR 2635.808, Fundraising Activities; 5 CFR 3501.105, Outside Employment and Activities; DO#21, 6.1.1 Maintaining the Integrity and Impartiality of, and Public Confidence in, NPS and the Department of the Interior, 6.1.2 Reviewing Direct Donations, 6.3.1 Donation Boxes, 10.2.6 In-Park Displays, Name Plaques, and Plates; DO#24, 4.3.4 Ongoing and Corrective Actions, 4.3.16 Project-generated Collections.

Human Resources

- Avoid requiring museum staff to act in conflict with this code of ethics or other international, national, or relevant professional codes of ethics.
- Ensure that employees, volunteers and visitors working with museum collections are informed of hazards inherent to the collections (such as pesticides) and protective measures.
- Ensure that all employees with direct responsibility for museum collections management have the knowledge, skill, and ability to perform assigned jobs.
- Foster a cooperative relationship between park cooperating associations and park staff in the interest of the museum collection.

See DO #24, 4.2.4 Staffing and Training, 4.3.11 Job Hazard Analysis.

5. *What ethics principles do I follow if I am responsible for the direct management of collections?*

In addition to the ethics principles in Sections B and C.4, your actions and decisions will follow the ethics principles below.

Acquisition, Disposal, and Documentation

- Fully and accurately document items in the museum collection and ensure that the documentation is current.
- Verify that all acquisitions and incoming loans have a legal and ethical pedigree, including required permits. Document in writing research related to this verification.
- Never traffic in objects and specimens originating on public lands.
- Avoid making any judgment for another party about the value of an object, archival document, or specimen. You may provide

information on obtaining appraisals, but not recommend any single appraiser.

- Cooperate with other institutions to ensure the preservation of significant cultural and natural heritage and avoid competing for acquisitions if such competition would endanger the integrity or safety of such materials.
- Make all deaccession actions open to public scrutiny.

See DO#24, 4.3.2 Standards, 4.3.13 Accession and Catalog Records; MH-II, Museum Records, Chapter 4 Inventory and Other Special Instructions, Section IX, Determining the Monetary Value of Museum Objects, Chapter 6 Deaccessioning.

Preservation and Protection

- Protect and preserve the integrity of collections.
- Avoid using methods and materials that may adversely affect museum collections or their future examination, scientific investigation, treatment or function.
- Document examination, scientific investigation, and treatment of collections for preservation purposes.
- Protect collections against physical threats and unauthorized access.
- Store, handle, use, and exhibit objects to maximize their long-term preservation unless destructive analysis or consumptive use is specifically authorized in writing according to DO#24, 4.2.7 Destructive Analysis and Consumptive Use, 4.3.25 Preservation vs. Destructive Use.

See Management Policies, Chapter 5 Cultural Resource Management; DO #24; MH-I.

Access and Exhibits

- Encourage use of the collections and data for research, exhibits, and education in order to increase public benefit. See also Section C.6.
- Ensure fair and equitable public access to collections, associated documentation, policies, and technical information.
- Maintain the confidentiality of data about the nature and specific location of 1) a national park system resource which is endangered, threatened, rare, or commercially valuable; 2) mineral or paleontological objects within units of the national park system; or 3) objects of cultural patrimony within units of the national park system,

unless the Secretary determines that disclosure would further NPS purposes and would not create an unreasonable risk of harm, theft or destruction of the resource or object, including individual organic or inorganic specimens, and disclosure is consistent with other applicable laws protecting the resource (National Parks Omnibus Management Act of 1998 [16 USC 5937]).

- Ensure that access is consistent with the laws and NPS policies pertaining to Freedom of Information Act disclosures, copyright, privacy, publicity, obscenity and pornography, defamation, and resource protection.
- Never use objects from the museum collection or museum venues for personal purposes, and inform your relatives that they are similarly restricted.
- Never exhibit Native American human remains or photographs of the remains. You may exhibit drawings, renderings or casts of remains with the consent of culturally affiliated Indian tribes and native Hawaiian organizations.
- Borrow and lend museum collections consistent with the Museum Act (16 USC 18f).
- Provide accurate, well-researched information to the public, and maintain accurate documentation about the collections in files and databases.
- Inform researchers of parallel research by others, and supply names if agreeable to the parties involved.
- Avoid borrowing and exhibiting collections from individuals who may have a conflict of interest or an appearance of a conflict of interest (for example, park staff).
- Ensure that reproductions, replicas, and copies are permanently marked as facsimiles to avoid confusion with the original.

See Management Policies, 4.1.2 Natural Resource Information, 5.2.3 Confidentiality, 5.3.4 Stewardship of Human Remains and Burials; DO #24, 4.3.28 Exhibit of Human Remains; MH-II, Chapter 2 Accessioning, Chapter 5 Outgoing Loans; MH-III, Chapter 1 Evaluating and Documenting Use, Chapter 2 Legal Issues, Chapter 4 Two-Dimensional Reproductions, Chapter 5 Three-Dimensional Reproductions.

Management

- Consult with affiliated parties in managing collections, including parties subject to the Native American Graves Protection and Repatriation Act.

See Management Policies, 5.2.1 Consultation; DO #24, 4.3.24 Consultation.

Professional Conduct

- Act in the best interests of the museum collection.
- Maintain current knowledge of and follow relevant professional standards and ethics.
- Seek the expertise and advice of colleagues when such input will benefit the museum collections and programs.
- Share information with colleagues and co-workers in order to benefit the museum profession at large, and credit sources for information received.
- Act only within the scope of your knowledge, and seek training to acquire needed knowledge and skills to perform your job.
- Maintain current knowledge of the safety of materials and procedures, and take appropriate protective measures when handling hazardous materials.
- If you perform personal research using NPS collections, inform your supervisor of the research; do the research on your own time, during regular hours when other members of the public also have access, and inform others doing parallel research.
- Obtain a permit in accordance with 36 CFR 2.5 to personally collect in a park for non-official purposes, and do such collecting off-duty. For information on permits and conditions see <http://science.nature.nps.gov/research/ac/ResearchIndex>.
- Avoid conflict of interest or apparent conflict of interest in pursuing professional activities outside your NPS job responsibilities. Some outside activities may benefit the NPS museum program, such as teaching; participating as an AAM Museum Assessment Program consultant or accreditation team member; or serving a local, regional, national, or international museum association, but be mindful of restrictions in 18 USC 208, Acts Affecting a Personal Financial Interest, and the appearance of a conflict of interest in personal and business relationships as described in 5 CFR 2635.502.
- Clear outside professional activities with your supervisor and servicing ethics official when done on official time. Such activities involving a professional organization may require an ethics Memorandum of Understanding (MOU) between NPS and the organization and/or a waiver in accordance with 18 USC 208(b)(1).
- Avoid using your official title when not representing NPS.

- When you obtain information while performing duties as a Government employee, avoid using that information for personal research or other outside activities, except when that information is also available to the general public.
- Avoid revealing or profiting from information gained through work with restricted collections.
- Have no personal business with dealers who also sell objects to parks.
- Avoid dealing (buying or selling for personal profit) in natural and cultural resources.
- Avoid personal collecting in the same subject area as the museum. If such a collection exists prior to park employment, you should:
 - provide the superintendent with a current inventory
 - keep the private collection in your residence or off of public lands
 - avoid lending items from the private collection for park use
 - avoid adding to the private collection while employed by the park
 - offer the park first option to buy any objects that you propose to sell from your private collection, in order to avoid the appearance of a conflict of interest.
- Never acquire anything for yourself that has formerly been part of any park museum collection. Inform your relatives that they are similarly restricted.
- Avoid using your official title, position, or authority to endorse a product, service, or enterprise, except in furtherance of a specific statutory authority authorizing such endorsement, such as in support of authorized fundraising efforts of friends groups and cooperating associations.
- Avoid irresponsible criticism of other museum professionals or institutions. Address complaints about professional or ethical behavior directly to the individual or institution.

See 18 USC 208, Acts Affecting a Personal Financial Interest; 5 CFR 2635.502, Personal and Business Relationships; 5 CFR 2635.702, Use of Public Office for Private Gain; 5 CFR 2635.703, Use of Nonpublic Information; DO #21, 3.1 Ethical Considerations.

6. *What ethics principles do I follow if I am responsible for interpretation or education programs in the park museum or involving the museum collection?*

Persons responsible for interpretation or education programs that involve the park museum and/or the museum collections will ensure that services:

- Focus on the park's resources and themes and park and servicewide mission.
- Present factual material that is accurate and based on current scholarship and science, and that maintains the intellectual integrity of the information.
- Are accessible to wide audiences, including those with impairments.
- Are available without discrimination. (See 43 CFR 17, subpart E.)
- Consider factors that might influence an individual's needs and interests, such as age, physical and intellectual ability, level of education, ethnicity, religion, social/economic status, sexuality, and gender.

See Management Policies, Chapter 7 Interpretation and Education; DO #6, Interpretation and Education.

See also section C.4 and 5, Access and Exhibits.

7. *What should I do if the Code of Ethics for NPS Museums conflicts with another code of ethics?*

Follow the Code of Ethics for NPS Museums, unless the conflict is with the Standards of Ethical Conduct for Employees of the Executive Branch, the Employee Responsibilities and Conduct, the Supplemental Standards of Ethical Conduct for Employees of the Department of the Interior, or the criminal statutes (see B.1). These regulations and statutes always take precedence.

8. *Where can I find assistance in resolving ethics issues specific to the Code of Ethics for NPS Museums?*

Contact the sources in section B.3. Ethics officials at the park, region, and Washington Office are specifically trained to address ethics issues of all types. As necessary, they will consult with the DOI ethics staff in the Office of the Solicitor before advising you. Regional curators will be especially helpful on ethics issues unique to museum collections or the museum profession. Contact information for park, regional, servicewide center, and Washington Office ethics officials is at <http://www.inside.nps.gov/waso/custommenu.cfm?lv=3&prg=37&id=4451>.

D. Codes of Ethics for Professional Organizations

American Association of Museums (AAM)

The AAM Code of Ethics for Museums is available at <http://www.aam-us.org/museumresources/ethics/coe.cfm>. Guidelines on specific ethics-related issues are available at <http://www.aam-us.org/museumresources/ethics/index.cfm>. The AAM publication entitled *Codes of Ethics and Practice of Interest to Museums* has codes from all the AAM Standing Professional Committees as well as standards and policy statements from related organizations. This publication and others on ethics are available through the AAM online bookstore at <http://www.aam-us.org/bookstore/index.cfm> or by contacting the AAM Bookstore at:

American Association of Museums
1575 Eye Street, NW, Suite 400
Washington, DC 20005
(202) 289-1818
Fax (202) 289-6578
E-mail bookstore@aam-us.org

The Curator's Committee of the American Association of Museums has a Curators Code of Ethics available at <http://www.curcom.org/ethics.php>.

The Society of American Archivists (SAA)

The SAA Code of Ethics for Archivists is available at http://www.archivists.org/governance/handbook/app_ethics.asp. Publication information is online at <http://www.archivists.org/catalog/index.asp>. For further information contact the SAA at:

The Society of American Archivists
527 S. Wells St., 5th Floor
Chicago, IL 60607
(312) 922-0140
Fax 312/347-1452
E-mail info@archivists.org

The American Institute for Conservation of Historic and Artistic Works (AIC)

The AIC Code of Ethics and Guidelines for Practice is available at <http://aic.stanford.edu/about/coredocs/index.html>. For further information on ethics, using a keyword, you can search the AIC Web site, including posted publications, such as

the *Journal of the American Institute for Conservation*. For additional information contact the AIC at:

The American Institute for Conservation of Historic and Artistic Works
1717 K Street, NW
Suite 200
Washington, DC 20006
(202) 452-9545
Fax (202) 452-9328
E-mail info@aic-faic.org

American Association for State and Local History (AASLH)

The AASLH Statement of Professional Standards and Ethics is available at <http://www.aaslh.org/ethics.htm>. For additional information contact the AASLH at:

American Association for State and Local History
1717 Church Street
Nashville, TN 37203-2991
(615) 320-3203
Fax (615) 327-9013
E-mail membership@AASLH.org

International Council of Museums (ICOM)

The ICOM Code of Ethics for Museums is accessible at http://www.icom.org/ethics_rev_engl.html. Using the Web site keyword search function, you may access additional sources on ethics. Further information is available through AAM or from ICOM headquarters at:

International Council of Museums
Maison de l'UNESCO
1, rue Miollis
75732 Paris cedex 15
France
+33(0) 1 4734 0500
Fax +33(0) 1 4306 7862
E-mail secretariat@icom.museum

Other Organizations

Many other organizations devoted to the preservation,

protection, and interpretation of natural and cultural resources have adopted codes of ethics for their members. Some organizations you might contact for additional information are:

American Anthropological Association
2200 Wilson Blvd, Suite 600
Arlington, VA 22201
(703) 528-1902
Fax (703) 528-3546
<http://www.aaanet.org>

American Institute of Biological Sciences
1444 I Street, NW, Suite 200
Washington, DC 20005
(202) 628-1500
Fax (202) 628-1509
E-mail admin@aibs.org
<http://www.aibs.org>

American Institute of Professional Geologists
1400 W 122nd Avenue, Suite 250
Westminster, CO 80234
(303) 412-6205
Fax (303) 253-9220
E-mail aipg@aipg.org
<http://www.aipg.org>

American Library Association
50 E. Huron
Chicago, IL 60611
1-800-545-2433
(312) 944-2641
E-mail membership@ala.org
<http://www.ala.org>

Archaeological Institute of America
Located at Boston University
656 Beacon Street, Fourth Floor
Boston, MA 02215-2006
(617) 353-9361
Fax (617) 353-6550
E-mail aia@aia.bu.edu
<http://www.archaeological.org>

Ecological Society of America
1707 H Street, NW, Suite 400

Washington, DC 20006
(202) 833-8773
Fax (202) 833-8775
E-mail esahq@esa.org
<http://www.esa.org>

The Geological Society of America
P.O. Box 9140
Boulder, CO 80301-9140
1-888-443-4472
(303) 357-1000
Fax (303) 357-1070
E-mail gsaservice@geosociety.org
<http://www.geosociety.org>

National Council on Public History
327 Cavanaugh Hall – IUPUI
425 University Boulevard
Indianapolis, IN 46202
(317) 274-2716
Fax (317) 278-5230
E-mail ncph@iupui.edu
<http://www.ncph.org>

National Education Association
1201 16th Street, NW
Washington, DC 20036-3290
(202) 833-4000
Fax (202) 822-7974
<http://www.nea.org>

Natural Science Collections Alliance
PO Box 44095
Washington, DC 20026-4095
(202) 633-2772
Fax (202) 633-2821
E-mail general@nscalliance.org
<http://www.nscalliance.org>

The Paleontological Society
P.O. Box 7075
Lawrence, KS 66044-7075
(785) 843-1235
Fax (785) 843-1274
E-mail paleosoc@allenpress.com
<http://www.paleosoc.org>

Society for American Archaeology
900 Second Street NE #12
Washington, DC 20002-3560
(202) 789-8200
Fax (202) 789-0284
E-mail headquarters@saa.org
<http://www.saa.org>

Society for Historical Archaeology
15245 Shady Grove Road, Suite 130
Rockville, MD 20850
(301) 990-2454
Fax (301) 990-9771
E-mail hq@sha.org
<http://www.sha.org/>

Society for the Preservation of Natural History Collections
See Web site for current contact information.
<http://www.spnhc.org/>

Society of Vertebrate Paleontology
60 Revere Dr., Suite 500
Northbrook, IL 60062
(847) 480-9095
Fax (847) 480-9282
E-mail svp@vertpaleo.org
<http://www.vertpaleo.org>

The Wildlife Society
5410 Grosvenor Lane
Bethesda, MD 20814-2144
(301) 897-9770
Fax (301) 530-2471
E-mail membership@Wildlife.org
<http://www.wildlife.org>

Appendix E: Scope of Collection Statement

	<u>Page</u>
A. Overview	E:1
What information will I find in this appendix?	E:1
Who can assist me in writing or revising my park's Scope of Collection Statement?	E:1
Are there any other resources that can help me prepare or revise my park's Scope of Collection Statement?	E:1
B. Evaluating Your Scope of Collection Statement	E:1
How do I evaluate a Scope of Collection Statement?	E:1
How do I use the Scope of Collection Statement checklist?	E:1
Where do I find the Scope of Collection Statement checklist?.....	E:2
C. List of Figures	E:2
Figure E.1 Example Approved Scope of Collection Statement.....	E:3
Figure E.2 Example Scope of Collection Summary	E:24
Figure E.3 Checklist for Evaluating Scope of Collection Statements.....	E:25

Appendix E: Scope of Collection Statement

A. Overview

1. *What information will I find in this appendix?*

You will find a Scope of Collection Statement checklist that you can use to review a draft or approved Scope of Collection Statement (SOCS). You also will find a sample completed SOCS. This appendix is a supplement to Chapter 2: Scope of Museum Collections.
2. *Who can assist me in writing or revising my park's Scope of Collection Statement?*

Contact your regional/SO curator for examples of approved SOCS that show how different parks have written their statement. If you have questions about what types of collections to include in the Types of Collections section, contact your park's interpretive staff, resource management staff, and other subject matter experts, as well as your regional/SO curator and other regional/SO discipline specialists.
3. *Are there any other resources that can help me prepare or revise my park's Scope of Collection Statement?*

Yes. Figure E.1 includes an example Scope of Collection Statement and Figure E.2 includes an example Scope of Collection Summary. These documents are available in electronic format. Contact your regional/SO curator to obtain copies that you can use as templates when developing or revising your park's Scope of Collection Statement and Scope of Collection Summary.

Refer to Chapter 2: Scope of Museum Collections, the resources listed in the bibliography of Chapter 2, and your regional/SO curator for additional information.

B. Evaluating Your Scope of Collection Statement

1. *How do I evaluate a Scope of Collection Statement?*

Use the Scope of Collection Statement checklist included in Figure E.3 to review a draft or approved SOCS.
2. *How do I use the Scope of Collection Statement Checklist?*

To use the Scope of Collection Statement checklist:

 - Enter the unit's complete name. A unit is a park, center, or office with a museum collection. Place an "X" in either the draft or approved block. Enter the date (month, day, and year) of the draft or approved document. Enter the name of the reviewer and date reviewed.
 - Place a checkmark in the "YES" column to indicate that the required wording is in the SOCS, that the wording is accurate, and that it is in the appropriate section.
 - Place a checkmark in the "NO" column to indicate that the required statement does not appear in the SOCS.
 - Place a checkmark in the "N/A" column to indicate that the question is not applicable to the SOCS.
 - Place an "X" in the "Note" column to indicate that there is an attached note pertaining to this question.

- There may be times when the reviewer cannot determine the answer to a specific checklist question. If this is the case, print “ND” meaning “Not Determined” in the “YES” column.

3. *Where do I find the Scope of Collection Statement Checklist?*

See Figure E.3 for the checklist. An unpunched full size checklist accompanies this appendix. Keep the full size checklist as a master and make copies for your use.

C. List of Figures

-
- Figure E.1 Example Approved Scope of Collection Statement
Figure E.2 Example Scope of Collection Summary
Figure E.3 Checklist for Evaluating Scope of Collection Statements

DEPARTMENT OF THE INTERIOR
NATIONAL PARK SERVICE
LEWIS MOUNTAINS NATIONAL PARK

Scope of Collection Statement

Prepared/Recommended by: _____
Museum Curator Date

Concurred by: _____
Chief of Resource Management Date

Approved by: _____
Superintendent Date

Figure E.1. Example Approved Scope of Collection Statement

TABLE OF CONTENTS

I. INTRODUCTION	1
A. Executive Summary.....	1
B. Purpose of the Scope of Collection Statement.....	1
C. Legislation Related to National Park Service Museum Collections.....	1
D. Park History, Significance, Purpose, Themes, and Goals	1
E. Laws, Regulations, and Conventions Related to Museum Collections.....	4
F. Structures, Landmarks, and Other Park Resources Listed on National or International Registries	5
II. TYPES OF COLLECTIONS	5
A. Cultural Collection	5
1. Archeology Collection.....	6
a. Artifacts and Specimens.....	6
b. Associated Field Records.....	7
2. Ethnology Collection.....	7
3. History Collection.....	8
4. Archival and Manuscript Collection.....	10
B. Natural History Collection.....	11
1. Biology Collection.....	12
a. Flora.....	12
b. Fungi.....	12
c. Mammals.....	12
d. Birds	13
e. Reptiles and Amphibians	13
f. Fish.....	13

Figure E.1. Example Approved Scope of Collection Statement (continued)

g. Insects and Arachnids	13
h. Other Invertebrates	14
i. Associated Field Records.....	14
2. Geology Collection	14
a. Rocks and Minerals.....	14
b. Associated Field Records.....	14
3. Paleontology Collection.....	14
a. Fossil Specimens.....	15
b. Associated Field Records.....	15
III. MUSEUM COLLECTIONS SUBJECT TO THE NATIVE AMERICAN GRAVES PROTECTION AND REPATRIATION ACT OF 1990.....	15
IV. ACQUISITION	15
V. USES OF COLLECTIONS	16
VI. RESTRICTIONS.....	17
VII. MANAGEMENT ACTIONS.....	18

Figure E.1. Example Approved Scope of Collection Statement (continued)

I. INTRODUCTION

A. Executive Summary

The park's museum collection includes both natural history and cultural collections. The park's natural history collection includes: mammal and bird collections; the herbarium, which includes nearly all species of vascular plants that occur in the park; paleontological collections from the Bear Valley Shale Formation; geological specimens from the Bear Valley Shale and Lewis Granite Formations; associated project documentation and reports. Other natural history collections within the museum collection include: fungi; reptiles and amphibians; fish; insects and arachnids. At present, these collections are relatively small, as little research pertaining to these disciplines has been conducted in the park to date.

The cultural collection includes: archeological materials systematically excavated from within the park's boundaries and associated field records (circa 1000 BCE – circa 1940); an ethnology collection of Paiute and Shoshone basketry, watercolors, beadwork, and textiles; historic objects associated with the area's 19th century miners, railroad workers, and homesteaders, and items related to the Civilian Conservation Corps and President Franklin D. Roosevelt's 1938 park vacation; archival and manuscript collections such as the Joseph Jakes papers, oral histories, photographs, and scientific and resource management records.

B. Purpose of the Scope of Collection Statement

This Scope of Collection Statement defines the scope of present and future museum collection holdings of Lewis Mountains National Park that contribute directly to the understanding and interpretation of the park's purpose, themes and resources, as well as those objects that the Service is legally mandated to preserve. It is designed to ensure that the museum collection is clearly relevant to the park.

C. Legislation Related to National Park Service Museum Collections

The National Park Service's (NPS) legal mandate for acquiring and preserving museum collections is contained in the Antiquities Act of 1906 (16 USC 431-433); the Organic Act of 1916 (16 USC 1 et. seq.); the Historic Sites Act of 1935 (16 USC 461-467); the Management of Museum Properties Act of 1955, as amended (16 USC 18f); the Reservoir Salvage Act of 1960, as amended (16 USC 469-469c); the National Historic Preservation Act of 1966, as amended (16 USC 470 et seq.); the Archeological and Historic Preservation Act of 1974, as amended (16 USC 469-4691-2); the Archaeological Resources Protection Act of 1979, as amended (16 USC 470aa-mm); the National Parks Omnibus Management Act of 1998 (16 USC 5901).

D. Park History, Significance, Purpose, Themes, and Goals

The enabling legislation (45 Stat. 616) which established Lewis Mountains National Park on June 12, 1928, states that the park was established to "...preserve from injury or spoliation the Lewis Mountains, Bear Valley, and Shawnee Lake..." as well as "...the structures, other works, and relics of prehistoric cultures contained therein..."

The Bear Valley Lodge, constructed by the Union Pacific Railroad in 1920, was acquired by the park in 1962 through the Mountain Foundation. Additional lands from the adjoining Lewis National Forest were added to the park in 1964 to "...preserve the historical, paleontological, and geological resources of the Buffalo Valley" (63 Stat. 981).

Figure E.1. Example Approved Scope of Collection Statement (continued)

Efforts to assemble a museum collection within the park began in 1929 when Superintendent Charles Jackson established a small museum within one room of the ranger station. The museum was very popular with visitors, and the collection quickly grew due to local donations of Native American, ranching, mining, and other “pioneer” materials as well as natural history specimens collected by the park staff. It was soon apparent that a separate museum building was needed to house this growing collection, and in 1934 the Civilian Conservation Corps (CCC) constructed the Bear Valley Museum.

In 1969, the Henderson Visitor Center (which includes museum exhibit galleries and collection storage space) was completed and the museum collection was moved to that building. Additional exhibit and collection storage space was added to the structure in 1992. Native American history exhibits that were determined through consultation to be offensive to traditionally associated groups (including NAGPRA-identified items) were removed from the museum in 1993. A new permanent exhibit focusing on Paiute and Shoshone tribal culture was developed in consultation with the two tribes and opened in 1995.

In 1988, the park hosted its first annual CCC Reunion. In the years since, the park has received numerous donations of park-related CCC museum objects. In 1998, these collections were moved to the newly renovated Bear Valley Museum, which reopened to the public as a CCC museum and reference library.

The park’s natural history collection originally included the herbarium, mammal, and bird collections. The majority of these specimens were collected in the 1930s, 1940s, and 1950s. A limited number of specimens were added to the collection over the next twenty years, primarily herbarium specimens collected by researchers from Boise State University. Since 1992, the natural history collection has experienced tremendous growth, a result of various resource management projects conducted within the park. These include inventory and monitoring, fire effects studies, ethnobotanical studies, historic landscape reports, and studies conducted by researchers from Boise State University, Oregon State University, the Smithsonian Institution, Stanford University, and the University of Utah. It is anticipated that this collection will continue to grow due to park resource management activities, the Inventory and Monitoring program, and other scientific research activities.

The park’s purpose, identified in the General Management Plan (1998) is to:

1. Preserve and protect the scenic beauty and unique geologic features of the Lewis Mountains and Bear Valley: jagged mountain peaks; alpine lakes and meadows; remarkable canyons; volcanic phenomena; fossiliferous deposits; rare sedimentation.
2. Preserve and protect the rare paleontological resources of the Buffalo Valley.
3. Preserve the archeological features that pertain to the prehistoric inhabitants of America and the ancestral Native American tribes.
4. Preserve the entire area intact for the purpose of scientific research.
5. Provide a variety of opportunities for visitors to learn about and enjoy the resources without degrading those resources.

The park’s General Management Plan (1998), Long-Range Interpretive Plan (1999), and Resource Management Plan (1998) state that the purpose of the park’s museum collection is to:

1. Increase knowledge, inspiration, and an awareness of preservation and stewardship among present and future generations through the effective use of exhibits, research, programs, and publications that are related to the park’s interpretive themes and resource management objectives and goals.

Figure E.1. Example Approved Scope Collection Statement (continued)

2. Support scientific research and resource management.
3. Assist in the establishment of a permanent database of all organisms found in the park.
4. Preserve important or locally significant species collected in response to specific research or interpretive needs.
5. Guarantee the protection of objects whose in-situ preservation cannot be assured.

The park's museum collection should also support the park's interpretive themes, identified in the Long-Range Interpretive Plan (1999):

1. Human Use

- a. Past Human Use: prehistoric and historic North American native cultures including Paleo and Archaic Indian, Shoshone, and Paiute (to 1928); Euro-American trappers, traders, and immigrants (1820–1928), Union Pacific Railroad (1870-1955); early National Park Service (1928-1940).
- b. Contemporary Human Use: a sanctuary with provisions for scientific use and controlled pursuits compatible with the park's purpose and significance.
- c. Desired Future Use: a sanctuary, but with an increased awareness on the part of citizens of their share in the responsibility of such protection. Future improvements to park infrastructure will serve as examples of sustainable design and construction.

2. Geologic History

Park geology and morphology span the last 250 million years: deposition, the uplift of the Lewis Mountains, creation of the Bear and Buffalo Valleys, lava flows during the past one million years (that created Shawnee Lake), and earthquakes.

3. Paleontological History

Within its many geologic formations, the park hides evidence of past life: from mountaintop fossilized seashells to dinosaur bones and footprints along the Buffalo River, from single ferns to petrified logjams.

4. Biological Diversity, Natural Processes, and Wilderness

- a. The park contains many diverse organisms. It preserves ongoing natural processes: geological and biological, which we deem inherently valuable.
- b. The park's many diverse and scientifically valuable resources are located in a wild land with few modern, man-made improvements. As such, they provide outstanding opportunities for preservation, study, and enjoyment.
- c. Wilderness is its own reason for existence. It provides a time capsule of processes and resources which should, to the greatest degree possible, be managed and preserved unencumbered by human intervention.

Figure E.1. Example Approved Scope Collection Statement (continued)

The park's Resource Management Plan (1998) identifies the following resource management objectives and goals:

Management Objectives

1. The park's resources and natural processes are defined, inventoried, and understood by park staff and form a basis for management strategies to fulfill the park's mission.
2. The public and visitor understand and support the missions of the park and the National Park Service. They are advocates of the goals to preserve the nation's heritage and enhance environmental citizenship.
3. The park is managed to assure long-term protection of cultural and natural resources. This includes monitoring impacts of human use in and around the park.
4. The park is managed as a part of a greater regional ecosystem and recognizes the needs of the park, other land management agencies, and private landowners.
5. Management of all park resources, including employees, visitors, and natural resources is recognized and valued worldwide and is a model for national and international managers.

Management Goals:

1. Identify, inventory, and assess the park's natural and cultural resources and natural processes in order to form the basis for management strategies.
2. Manage park resources through a regional ecosystem approach and through cultural contexts.
3. Identify and evaluate the effects of human-caused impacts to park resources to form the basis for implementing management strategies.
4. Based on management strategies, provide a variety of visitor experiences compatible with resource protection.

E. Laws, Regulations, and Conventions Related to Museum Collections

Archeological collections, except inalienable and communal property (as defined by the Native American Graves Protection and Repatriation Act of 1990 [25 USC 3001-13]), recovered from within park boundaries through systematic collection are Federal property and must be retained in the park's museum collection in accordance with 43 CFR 7.13 and NPS *Management Policies* (2001).

In accordance with the NPS Research Permit and Reporting System, permits to collect natural resource specimens state that retained specimens remain Federal property, are incorporated into the park museum collection and, as required by 36 CFR 2.5g, must bear official National Park Service museum labels and their catalog numbers will be registered in the National Park Service National Catalog.

Other laws, regulations, directives and conventions pertinent to the acquisition of museum collections at the park include: the Lacey Act of 1900 (18 USC 43-44); the Migratory Bird Treaty Act of 1918 (16 USC 703-711); the Bald Eagle Protection Act of 1940, as amended (16 USC 668-668d); the Federal Property and Administrative Services Act of 1949, as amended (40 USC 483[b]); the Federal Records Act of 1950, as

Figure E.1. Example Approved Scope Collection Statement (continued)

amended (“Records Management by Federal Agencies” [44 USC 3101 et. seq.]); the Freedom of Information Act of 1966, as amended (5 USC 552); the Marine Mammal Protection Act of 1972 (16 USC 1361-1407); the Endangered Species Act of 1973, as amended (16 USC 1531-1543); the Privacy Act of 1974 (5 USC 552a); the Copyright Act of 1976 (17 USC 101 et seq. [1988 & Supp. V 1993]); the American Indian Religious Freedom Act of 1978 (42 USC 1996); the Native American Graves Protection and Repatriation Act of 1990 (NAGPRA) (25 USC 3001-3013); Federal Property Management Regulations (FPMR), 41 CFR 101; 410 Departmental Manual, Interior Property Management Regulations (IPMR); 411 Departmental Manual, “Managing Museum Property,” Chapters 1-3; “Curation of Federally-Owned and Administered Archeological Collections,” 36 CFR 79; NAGPRA Final Regulations, 43 CFR 10; “Disposition of Federal Records,” 36 CFR 1228; “Protection of Archeological Resources”, 43 CFR 7; “Preservation of American Antiquities”, 43 CFR 3; “Preservation, Arrangement, Duplication, Exhibition of Records” (44 USC 2109); “Disposal of Records” (44 USC 3301 et seq.); Director’s Order #19: Records Management; Director’s Order #24: NPS Museum Collections Management; Director’s Order #28: Cultural Resource Management; Director’s Order #44: Personal Property Management; the 1983 Convention on International Trade in Endangered Species of Wild Fauna and Flora (CITES); the 1970 UNESCO Convention on the Means of Prohibiting and Preventing the Illicit Import, Export, and Transfer of Ownership of Cultural Property (implemented in the United States by P.L. 97-446 in 1983, 19 USC 2601).

F. Structures, Landmarks, and Other Park Resources Listed on National or International Registries

Historic resources within the park listed on the National Register of Historic Places include: Buffalo Valley Archeological District; Shawnee Lake Rendezvous Site; Lewis Mountain Railroad Tunnel; Shawnee Lake Mine Historic District; Bear Valley Lodge; Bear Valley Ranger Station, Museum, Maintenance Facility, Ranger’s Residence, Comfort Station, and Amphitheater; East Entrance Sign, Checking Station, and Ranger’s Residence; Lewis Mountain Highway and Tunnel.

The park was designated a Biosphere Reserve in 1984.

II. TYPES OF COLLECTIONS

The interpretive themes and resource management goals and objectives stated in the introduction provide direction for the acquisition of museum objects. The following guidelines will prevent arbitrary and excessive growth of the collection, while ensuring that it remains relevant to the park’s mission.

A. Cultural Collection

The purpose of this collection is to increase knowledge and inspiration among present and future generations through exhibits, research, and interpretive programs; support research, resource management and education; provide baseline data of park cultural resources; document changes these resources are undergoing because of internal park conditions and external effects; to guarantee the protection of important objects whose in-situ preservation cannot be assured.

Objects and archival collections with a direct association to the park are more desirable for inclusion within the collection than similar items without such primary significance. The cultural collection is subdivided into four disciplines: archeology, ethnology, history, and archives and manuscripts. The following list identifies, by discipline, object types appropriate to the park’s museum collection and, as needed, notes current representation.

Figure E.1. Example Approved Scope Collection Statement (continued)

The cultural collection must support these goals. This will ensure that only relevant objects and archival materials are accessioned into the collection. Future growth of the collection should be restricted to items related to:

1. Interpretive and/or research needs identified in the park's General Management Plan (1998), Resource Management Plan (1998), Long-Range Interpretive Plan (1999), historic furnishings reports, exhibit plans, and other applicable park planning documents and resource studies.
2. Enhancing understanding of and promoting increased stewardship of the park's cultural resources.
3. Cultural resources baselines/inventorying and monitoring activities.
4. Regulatory and compliance activities such as those mandated by the National Historic Preservation Act of 1966, as amended and the Archaeological Resources Protection Act of 1979 (ARPA).

1. Archeology Collection

Archeological collections are generated in response to cultural resource management requirements related to legal mandates, to development of park facilities, to preservation-related activities, to research requirements, and to interpretive needs. The archeological collection includes artifacts, human remains, and other materials obtained using archeological methods.

As per 43 CFR Part 7, any archeological materials discovered within the park (except inalienable and communal property, as defined by NAGPRA) are the property of the United States and will be maintained as a part of the park's museum collection.

a. Artifacts and Specimens

Archeological research projects within the park may result in the collection of artifacts, ecofacts, or other data.

Park staff and visitors should be discouraged from picking up surface artifacts. It is preferred that surface artifacts be left in-situ and their location documented. If materials are collected and brought to park staff, appropriate measures must be taken to ensure that the visitor collects no more material, that precise provenience information is recorded, if possible, and that the objects/data are promptly given to the curatorial staff upon receipt by staff members.

The park's archeology collection includes:

- 1) **Prehistoric Material.** The collection contains 2000 prehistoric Native American items (projectile points, flaked stone, ground stone, and pottery sherds), including twenty items associated with Paleo and Archaic Indian sites within the park.
- 2) **Historic Material.** The collection contains material from sites related to the settlement of the lands within the park during the historic period (through 1942), and sites associated with early park development, from circa 1920 through 1942. Materials from both Native American sites and Euro-American sites are included in this category. This collection consists of over 4,000 artifacts, including knives, projectile points, flaked stone, ground stone, pottery, household items, tools, glass, porcelain and ceramic sherds, objects related to mining and railroads, and other items.

Figure E.1. Example Approved Scope Collection Statement (continued)

3) **Confiscated Archeological Objects.** These are objects recovered from unauthorized and illegal activities. They might include unearthed artifacts, ecofacts, and human remains illegally excavated or uncontrolled surface collecting by unauthorized individuals within the park boundaries. The museum curator should be consulted as soon as possible to ensure proper handling and transportation of these materials. Such objects might be held temporarily as evidence if legal action is to be taken, but should be formally turned over to the museum curator as soon as possible. Once all legal questions are resolved, the objects and all associated documentation will be added to the museum collection.

b. Associated Field Records

All records associated with archeological collections are retained as part of the museum collection. These records include field notes and catalogs, daily journals, drawings and maps, photographs and negatives, slides, sound recordings, raw data sheets, instrument charts, remote sensing materials, collection inventories, analytical study data, conservation treatment records, computer documentation and data, as well as any other documents generated through archeological activity.

2. Ethnology Collection

The park has important ties to both the Paiute and Shoshone tribes. The ethnology collection is an important component of the park's interpretive and resource management programs and furthers the park's mission. The collection is noted in the Long-Range Interpretive Plan (1999) and is an important element of the plan's Human Use section. The collection's importance is also noted in the General Management Plan (1998), especially concerning tribal consultation and traditional uses of park resources by tribal members.

a. Objects. Acquired, mostly through gifts between 1928 and 1976, the ethnology collection presently includes examples of Native American material culture from the Great Basin, Northwest, and adjacent culture areas. These artifacts illustrate the cultural continuity of the Native American cultures of the area, as well as their cultural adaptation and change as seen through their material culture. They also illustrate Native American artistic traditions in the vicinity and provide examples of the arts and crafts of groups with whom the park has been associated.

The collection consists primarily of Paiute basketry, watercolors, beadwork, and textiles. There are also several fine examples of Shoshone basketry, beadwork, and textiles, most notably the Lillian Wood Collection, acquired by loan in 1976.

b. Associated Records. All records associated with ethnographic collections are retained as part of the museum collection. These records may include field notes; interview schedules, tapes (video and audio), interview transcripts; negatives, prints and slides; data sheets (all subject to restrictions of confidentiality, if any); artifact inventories; analytical study data; computer documentation and data; reports generated by ethnographic investigations; as well as any other documents generated through ethnographic field work.

c. Future Collections Activity. The park will continue to acquire ethnographic material from the Paiute and Shoshone tribes, as well as other Native American groups that have aboriginal, historic, or religious ties to park lands, if such collections will address an interpretive and/or research need identified in the Ethnographic Overview and Assessment (1996), Long-Range

Figure E.1. Example Approved Scope Collection Statement (continued)

Interpretive Plan (1999), Resource Management Plan (1998), cultural affiliation studies, exhibit plans, or other park planning documents. All such future collections activities will proceed in close cooperation with Paiute and Shoshone tribal councils, cultural resource management officers, and councils of Elders.

1) **Lillian Wood Collection**

The entire collection of Shoshone material culture items consists of the Lillian Wood Collection, which is on loan to the park. This collection is a superb representation of the area's Shoshone culture, circa 1840-1950, and is a vital component of the park's interpretive and research programs. Mrs. Wood's estate is committed to the collection remaining at the park, and the Shoshone tribe and Council of Elders concur. However, the park may be required to purchase the items in order to ensure that they remain at the park. To this end, the park's cooperating association, the Lewis Mountains Association and the Friends of the Lewis Mountains have established a fund-raising campaign to enable the park to purchase the collection outright.

2) **Modern Works**

During the General Management Plan process, the park and its stakeholders determined that the then-current ethnology collection did not include more recent representations of the area's Paiute and Shoshone material cultures. In response, both the General Management Plan (1998) and Long-Range Interpretive Plan (1999) stress the importance of acquiring a limited number of modern works "...to illustrate the endurance of the area's original Native Peoples, and the continuation and evolution of their culture, arts, and livelihoods through to the present era." The park has since acquired three modern Paiute baskets and two paintings in consultation with Paiute tribal authorities and Elders. Recent consultations with Shoshone Elders determined the need to obtain modern Shoshone textiles and paintings to address these interpretive deficiencies.

3. **History**

The history collection is an important component of the interpretive and resource management programs and supports the mission of the park. The collection's importance is noted in the Human Use section of the Long-Range Interpretive Plan (1999). The General Management Plan (1998) states that the collection is a "vital element in the interpretation and resource management of historic structures, sites, and other indicators of human use within the present boundaries of the park."

Only historic material that has a direct association with the park is included in the museum collection. When a large quantity of an object type is available, priority is given to acquiring the best-preserved examples. The history collection is based on the park's themes used to establish the following collecting categories:

- a. **Historic Era: Native American Inhabitants, Euro-American Exploration, Fur Trade, Railroad, Mining, and Homesteading (Pre-1920).** There are few objects directly associated with historic era Native American inhabitants, Euro-American exploration, and the fur trade in the collection. It is unlikely that such material of this type will become available, however

Figure E.1. Example Approved Scope Collection Statement (continued)

the park should attempt to obtain an early 19th Century beaver trap to fulfill a deficiency noted in the Henderson Visitor Center Exhibit Plan (1992).

The collection includes several outstanding examples of excavation equipment, tools, and other items associated with the area's 19th century miners, railroad workers, and homesteaders, including the Jakes Collection (first family of homesteaders in the area, now part of the park).

- b. Early Park Development (1920-1940).** Material in this category includes a Union Pacific/Bear Valley Lodge bus, historic furnishings, staff personal items (e.g., Superintendent Jackson's badge, 1928-35). The park will continue to collect staff members' personal items, furnishings, and other materials that address an interpretive and/or research need identified in an interpretive plan, exhibit plan, or other park planning document.
- c. Civilian Conservation Corps (CCC, 1933-1942).** The CCC played an important role in the development of the park and in the preservation of its resources. Items in the museum collection from this period include: historic furnishings, copies of administrative records, construction drawings, photographic documentation of projects, tools, artwork (exhibition illustrations, personal sketches and watercolors), and architectural features. If additional material documenting park CCC activities becomes available, it should be collected when it does not duplicate what is presently available. Areas where documentation is incomplete include camp life, identification of personnel in the photographic records on hand, and copies of camp publications such as the *Bear Valley Camp News*.

Many of the park's administrative, maintenance, and residential buildings were either constructed or significantly modified during the CCC period, and are listed on the National Register of Historic Places.

Some works of art, created as exhibition illustrations, have been included in the museum collection. Other important examples remain in the exhibits and these, along with some individual exhibits (dioramas in the Bear Valley Museum) should become part of the museum collection.

- d. Commemorative Events.** Memorabilia from important current or commemorative events are included in the museum collection. Materials related to President Franklin D. Roosevelt's 1938 park vacation and the park's 75th anniversary have been included. Materials from these types of important park activities will continue to be preserved as they become available.
- e. Historic Fabric.** When original fabric is removed from a historic structure during a preservation or repair project, a representative portion of the fabric will be preserved and accessioned into the museum collection, along with any associated documentation.
- f. Future Collections Activity.** Future collections activity in this area will concentrate on the acquisition of outstanding examples of objects currently not represented in the collection, which meet the criteria referenced above and clearly correct an interpretive or research deficiency noted in the park's General Management Plan (1998), Long-Range Interpretive Plan (1999), future exhibit plans, or other planning documents. This will ensure that the history collection is relevant to the interpretive and research needs of the park.

Figure E.1. Example Approved Scope Collection Statement (continued)

4. Archival and Manuscript Collection

The park's archival collection includes oral histories with local residents (including oral histories conducted in 1955 with Mrs. Elsie Johnson and other tribal elders); duplicate copies of administrative records such as Superintendent's Reports and Chief Naturalist's Reports; photographic prints, negatives, and slides; photographs, blueprints, specifications and other items documenting facility development; materials related to scientific studies and resource management activities (Peregrine Falcon studies, mine preservation studies, wilderness areas, etc.); the Josiah Jakes Papers (personal papers of the first Euro-American homesteader in Bear Valley).

Policy and procedures for archival collections and records management are outlined in NPS *Management Policies* (2001), Director's Order #19: Records Management (2001), the *Museum Handbook*, Part II, Appendix D: Archives and Manuscript Collections, and the NPS *Records Disposition Schedule* (1986).

Library Materials

A small number of library materials (e.g., rare books and manuscripts) are included in the museum collection. The park library contains other rare books (e.g., Jonas Fredericson's 1881 publication *Travels Through the Lewis Mountains*) that should also be included in the museum collection. Rare books and original manuscripts, having direct association with the park will continue to be included in the museum collection.

The park's library includes a large number of books that are out of print, technical references, and administrative documents. This material, though valuable, will not be included in the museum collection and will continue to be managed under the park's library management plan. The library and printed matter in the museum collection both support the park's research, interpretive, and resource management programs.

Future Collections Activity

In accordance with Director's Order #19: Records Management (2001) and the NPS *Records Disposition Schedule* (1986), the park Records Management Committee examines all current park files before they are transferred to the National Archives and Records Administration or disposed of, to ensure the retention of copies of important official records in the park. Other materials to be retained include materials related to scientific studies and resource management activities; oral histories, historic resource studies, and similar reports; photographs, blueprints, specifications and other items documenting facility development. Retained materials are managed as part of the museum collection.

In 2002, park staff learned of the existence of two diaries and several letters (circa 1860) kept by Betsy Jakes, niece of Josiah Jakes. These items are currently in the possession of Mrs. Dorothy Samuels of Santa Barbara, California. As these materials document many previously unknown aspects of the area's Euro-American settlement, acquisition of them by the park would constitute an important addition to the collection. The park recently obtained copies of these materials, and Mrs. Samuels has expressed willingness to bequeath the originals to the park. Obtaining these items is a high priority and park staff will continue to work with Mrs. Samuels in this regard.

Figure E.1. Example Approved Scope Collection Statement (continued)

B. Natural History Collection

Purpose

The purpose of this collection is to support scientific research, resource management and education; provide baseline data of park natural resources; document changes these resources are undergoing because of internal park conditions and external effects; provide a database for researchers concerned with resources use by the park's prehistoric occupants; preserve important or locally significant species collected in response to specific research or interpretive needs; to guarantee the protection of important paleontological specimens whose in-situ preservation cannot be assured.

The natural history collection must support these goals. This will ensure that only well-documented and appropriate specimens are retained. Future growth of the collection should be restricted to specimens and associated records generated through:

1. Authorized scholarly research and selective acquisition based on:
 - Needs identified in the park's General Management Plan (1998), Resource Management Plan (1998), and other applicable park planning documents and resource studies
 - Servicewide initiatives such as the Natural Resource Challenge
 - Enhancing understanding of and promoting increased stewardship of the park's ecosystem
2. Inventorying and Monitoring Activities
3. Regulatory and compliance activities such as those mandated by the National Environmental Policy Act of 1969 (NEPA), as amended

Scholarly research may be conducted by park or non-park scientists. All collecting activities must be in compliance with 36 CFR 2.5, the Research Permit and Reporting System, Director's Order #77: Natural Resource Protection (under development), and NPS *Natural Resources Management Guideline* (1991). All researchers must comply with applicable state and Federal laws regulating collecting, documenting collections, and other associated activities. No collector (including park staff) can work in the park without first obtaining a signed permit. The collections section of the permit application must be completed, documenting where collections of specimens and associated records will be housed. Questions related to collecting within the park should be addressed to the park's research coordinator.

Three separate areas of the park, with a total of 8,100 acres, were designated as wilderness in 1973. Alpine Meadow received designation as a "Research Natural Area" in 1969. All collecting of natural resource specimens that impacts these areas must take into consideration restrictions in effect because of these special designations.

Natural resource specimens collected outside the park boundaries will not be included in the collection unless the specimens are required to illustrate interpretive exhibits, to augment specific park-related research projects, or to demonstrate effects on park resources. Written permission from landowners or appropriate officials is obtained when collecting occurs on their land. This documentation or copies must become part of the museum collection's accession file.

Figure E.1. Example Approved Scope Collection Statement (continued)

Taxidermy “mounts” and freeze-dried specimens will be obtained only when a specific need (such as for an exhibit) is identified. Specialty collections such as frozen or other types of tissue samples are beyond the capability of the park to preserve. If they are collected and held by other repositories, they will be accessioned and cataloged in the park’s collection. Archived soils and other strictly environmental monitoring samples will only be collected as part of authorized research projects.

This collection is divided into three disciplines: biology, geology, and paleontology. The following list identifies the categories of specimens that are to be included in the museum collection and notes their current representation.

1. Biology

- a. **Flora.** Major herbarium collections of vascular plants were made in the 1940s and 1960s. Thus, nearly all species are represented in the herbarium. The non-vascular flora are not well represented in the herbarium. One research project has been conducted in this area; a lichen study was conducted in 1981. Specimens from this project are stored in the park’s herbarium. Duplicate specimens are on a repository loan to the University of Utah. It is anticipated that the herbarium collection will continue to grow as a result of park resource management activities (inventory and monitoring, fire effects, etc.) and authorized scholarly research.

Two state-listed rare plant species have been identified in the park: *Spiranthes diluvialis* and *Astragalus aquilonius* (Barneby) Barneby. Researchers must comply with all regulations governing these species.

Note: A teaching collection of herbarium specimens has been developed by the park’s interpretive staff. This collection consists of specimens located in the park’s Discovery Center, the Environmental Education Center, and additional specimens used for interpretive programs. This collection is managed for consumptive use by the Division of Interpretation; it is not part of the museum collection.

- b. **Fungi.** The fungi collection currently consists of fifty-two specimens collected in 1998 by a researcher from Stanford University. These specimens are currently housed at Stanford University. It is anticipated the fungi collection will continue to grow in the future, as a result of inventory and monitoring, other park resource management activities, and authorized scholarly research.
- c. **Mammals.** The majority of the mammal specimens in the collection were collected in the 1930s. Not all species found in the park are represented. A major research study of small mammals was conducted from 1989-1994. The study included the collection and preservation of small mammal species found in the park. It is anticipated the collection will continue to grow in the future, as a result of inventory and monitoring, other park resource management activities, and authorized scholarly research. The mammal collection is housed at the park.

No known endangered, threatened, or rare species are known in the park.

Note: A teaching collection of mammal specimens has been developed by the park’s interpretive staff. These specimens include animals accidentally killed on nearby roads, seizures of illegal game by the state Department of Fish and Game and U.S. Fish and Wildlife Service, and skeletal materials. The collection consists of specimens located in the park’s

Figure E.1. Example Approved Scope Collection Statement (continued)

Discovery Center, the Environmental Education Center, and additional specimens used for interpretive programs. This collection is managed for consumptive use by the Division of Interpretation; it is not part of the museum collection.

- d. **Birds.** The majority of the bird specimens presently in the collection were collected in the 1930s. Not all species found in the park are represented. It is anticipated the collection will continue to grow in the future, as a result of inventory and monitoring, other park resource management activities, and authorized scholarly research.

Two threatened, endangered, or rare species have been recorded in the park. These are: *Haliaeetus leucocephalus* and *Falco peregrinus*. Researchers must comply with all regulations governing these species.

Note: A teaching collection of bird specimens has been developed by the park's interpretive staff. These specimens include animals found dead, specimens seized by the state Department of Fish and Game and U.S. Fish and Wildlife Service, abandoned eggs and nests, and skeletal materials. The collection consists of specimens located in the park's Discovery Center, the Environmental Education Center, and additional specimens used for interpretive programs. The collection includes two examples of *Haliaeetus leucocephalus* and one *Aquila chrysaetos*. This collection is managed for consumptive use by the Division of Interpretation; it is not part of the museum collection. All required permits are maintained by the Division of Interpretation.

- e. **Reptiles and Amphibians.** Few species of reptiles and amphibians are currently represented in the museum collection. No major scientific studies involving reptiles and amphibians in the park have been undertaken to date. It is anticipated this collection will grow in the future, as a result of inventory and monitoring, other park resource management activities, and authorized scholarly research.

No known threatened, endangered, or rare species are found in the park.

- f. **Fish.** The Bear River flows through the central portion of the park. Other bodies of water in the park include Shawnee Lake and numerous other small lakes and streams. The aquatic life found in these bodies of water in the park have not been studied to date. It is anticipated this collection will grow in the future, as a result of inventory and monitoring, other park resource management activities, and authorized scholarly research.

- g. **Insects and Arachnids.** The park's insect collection dates from the 1970s. It is a fairly extensive collection resulting from a cooperative agreement with Oregon State University. The collection also includes insect larvae and soft-bodied arachnids preserved in 70% ethanol.

It is anticipated that this collection will grow in the future, as a result of inventory and monitoring, other park resource management activities, and authorized scholarly research. Species of importance in park management (such as parasites, museum pests, and others potentially requiring control measures) should be similarly represented. This collection is stored at the park.

No known rare, threatened, or endangered species are found in the park.

Figure E.1. Example Approved Scope Collection Statement (continued)

Note: A teaching collection of insect specimens has been developed by the park's interpretive staff. These specimens include those located in the park's Discovery Center, the Environmental Education Center, and additional specimens used for interpretive programs. This collection is managed for consumptive use by the Division of Interpretation; it is not part of the museum collection.

- h. Other Invertebrates.** Invertebrates other than those referred to above, both aquatic and terrestrial, are not well documented in the park. A small collection of dried land snail shells was made in the 1930s. It is anticipated that this collection may grow in the future, as a result of inventory and monitoring, other park resource management activities, and authorized scholarly research.
- i. Associated Records.** All records associated with specimens collected in conjunction with biological research are retained in addition to the specimens as part of the museum collection. Archival collections supplement future researchers' understanding of these collected specimens. These records include field notes; daily journals; maps and drawings; photographic negatives, prints, and slides; videotapes; sound recordings; raw data sheets; remote sensing data; copies of contracts; correspondence; repository agreements; specialists' reports and analyses; reports and manuscripts; specimens inventories and field catalogs; analytical study data; computer documentation and data; tabulations and lists; reports on all scientific samples lost through destructive analysis.

2. Geology

- a. Rocks and Minerals.** The collection contains a number of hand specimens, soil specimens, and mineral specimens that document the major rock types, formations, soils, and minerals found in the park. Additional specimens may be added to the collection as a result of resource management activities or other authorized scientific research.

Note: A small teaching collection of rock and mineral hand specimens has been developed by the park's interpretive staff. These specimens include those located in the park's Discovery Center, the Environmental Education Center, and additional specimens used for interpretive programs. This collection is managed for consumptive use by the Division of Interpretation; it is not part of the museum collection.

- b. Associated Records.** All records associated with specimens collected in conjunction with geological research are retained in addition to the specimens as part of the museum collection. Archival collections supplement future researchers' understanding of these collected specimens. These records include field notes; daily journals; maps and drawings; photographic negatives, prints, and slides; videotapes; sound recordings; raw data sheets; remote sensing data; copies of contracts; correspondence; repository agreements; specialists' reports and analyses; reports and manuscripts; specimen inventories and field catalogs; analytical study data; computer documentation and data; tabulations and lists; reports on all scientific samples lost through destructive analysis.

3. Paleontology

Uncontrolled surface collecting by visitors and park staff is prohibited. Fossils found on the surface by visitors should not be removed from their original location by the finder. They should be reported to park staff. If materials are turned in to park staff, appropriate measures must be

Figure E.1. Example Approved Scope Collection Statement (continued)

taken to ensure that the visitor collects no more material, that precise provenience information is recorded, if possible, and that the objects/data are promptly given to the museum curator upon receipt by staff members.

- a. **Fossil Specimens.** The collection contains a representative and well-documented collection of invertebrates, mainly from the Bear Valley Shale Formation that were collected in the 1950s and 1960s. An additional twenty-nine specimens were collected in 1992, and are located at Boise State University. It is anticipated that this collection may grow in the future, as a result of park resource management activities and authorized scholarly research.
- b. **Associated Records.** All records associated with specimens collected in conjunction with paleontological research are retained in addition to the specimens as part of the museum collection. Archival collections supplement future researchers' understanding of these collected specimens. These records include field notes; daily journals; maps and drawings; photographic negatives, prints, and slides; videotapes; sound recordings; raw data sheets; remote sensing data; copies of contracts; correspondence; repository agreements; specialists reports and analyses; reports and manuscripts; specimen inventories and field catalogs; analytical study data; computer documentation and data; tabulations and lists; reports on all scientific samples lost through destructive analysis.

III. MUSEUM COLLECTIONS SUBJECT TO THE NATIVE AMERICAN GRAVES PROTECTION AND REPATRIATION ACT OF 1990

The Native American Graves Protection and Repatriation Act of 1990 (NAGPRA), 25 USC 3001-13, requires, in addition to other actions, a written summary of unassociated funerary objects, sacred objects, and objects of cultural patrimony. The park's holdings that fall into these NAGPRA categories are listed in a Servicewide summary that was distributed to all Indian Tribes, Alaska Native villages, and Native Hawaiian organizations on October 27, 1993. An updated copy of this summary is on file at the park.

NAGPRA requires a written, item-by-item inventory of human remains and associated funerary objects to be completed no later than November 16, 1995. The park has human remains and associated funerary objects subject to NAGPRA in its museum collection. A detailed listing of these items is contained in the park's NAGPRA Inventory, completed October 10, 1995. An updated copy of this inventory is on file at the park.

IV. ACQUISITION

The park acquires objects for its museum collections by gift, purchase, exchange, transfer, field collection, and loan. Museum objects must be acquired, accessioned, and cataloged in accordance with *Museum Handbook*, Part II, Museum Records. Acquisition of museum objects are governed by the park's ability to manage, preserve, and provide access to them according to *NPS Management Policies* (2001), Chapter 5; the standards for managing museum objects in Director's Order #28: Cultural Resource Management (1998), *Cultural Resource Management Guideline* (1997), and Director's Order #24: NPS Museum Collections Management; the *NPS Museum Handbook*, Part I, Museum Collections and Part III, Access and Use.

In accordance with NPS policy, the park will prohibit the acquisition of gifts with restrictions or limiting conditions. Such restrictions include copyrights; the park will acquire copyrights to all incoming accessions. Incoming loans will be acquired only for a particular purpose such as research or exhibition,

Figure E.1. Example Approved Scope Collection Statement (continued)

and for a specified period of time. Museum objects are acquired, accessioned, and cataloged in accordance with the NPS *Museum Handbook*, Part II, Museum Records.

The park will not be a partner to, or encourage in any way, the trafficking in illicitly collected materials. All acquisitions must be collected, exported, imported, transported, or otherwise obtained and possessed in full compliance with the laws and regulations of the country of origin, the United States federal government (including NAGPRA), and the individual states of the United States.

The acquisition of firearms included on the Bureau of Alcohol, Tobacco, and Firearms (ATF) list of prohibited/restricted weapons requires concurrent review by the regional/SO curator and the regional/SO law enforcement specialist.

The park superintendent, by delegation, represents the Director of the National Park Service and the Secretary of the Interior in accepting title to and responsibility for museum objects. The superintendent will ensure that all collections acquired are in keeping with this Scope of Collection Statement before accepting the items as part of the permanent collection. The superintendent bears the ultimate responsibility for the acquisition and proper care and management of the museum collection. The superintendent has delegated the day-to-day care of the collection to the museum curator.

All acquisitions must receive formal approval from the superintendent before they can be accepted into the museum collection. Upon receipt, all newly acquired objects and related documentation must be turned over to the museum curator. The museum curator prepares, for the superintendent's signature, all instruments of conveyance, and letters of thanks, acceptance, or rejection, and transmits them as appropriate, to the donor, lender, vendor, or other source of acquisition.

V. USES OF COLLECTIONS

The park's museum collection may be used for exhibits, interpretive programs, research, publications, or other interpretive media. The primary considerations for the use of museum objects are the preservation of each object in question and of the collection as a whole, and accurate interpretation.

In accordance with NPS *Management Policies* (2001), Chapters 5 and 7, the park will not exhibit Native American human remains or photographs of those remains. Drawings, renderings, or casts of such remains will not be displayed without the consent of culturally affiliated Indian tribes and Native Hawaiian organizations. The park will consult with culturally affiliated or traditionally associated peoples to determine the religious status of any object whose sacred nature is suspected but not confirmed. These consultations will occur before such an object is exhibited or any action is taken that may have an adverse effect on its religious qualities.

Researchers and other specialists may examine objects and archival materials under the conditions and procedures outlined in Director's Order #24: NPS Museum Collections Management, Director's Order #28: Cultural Resource Management (1998), Cultural Resource Management Guideline (1997), and in the park's written "Museum Collections Access Procedures." Outside researchers must submit a research proposal to the superintendent for review by the park's Research Coordinator and other staff as appropriate. If applicable, the research proposal may be presented for review during consultation with the Paiute and Shoshone tribes before access to certain items in the collection is granted.

Any interpretive use defined as consumptive must be authorized in advance, as outlined in Director's Order #24: NPS Museum Collections Management, Director's Order #28: Cultural Resource Management (1998), *Cultural Resource Management Guideline* (1997), and Director's Order #6: Interpretation and Education (Draft, 2002). The use of reproductions is preferred to the consumptive use of original objects.

Figure E.1. Example Approved Scope Collection Statement (continued)

Destructive analysis is a legitimate use of museum collections for approved research purposes when the impact is minor or when the object is common, in which case approval by the superintendent is required. If an object is rare or significant, a request for destructive analysis should be reviewed by the regional/SO curator and may be approved only by the regional director, as outlined in Director's Order #24: NPS Museum Collections Management, Director's Order #28: Cultural Resource Management (1998) and *Cultural Resource Management Guideline* (1997).

Objects may be loaned out to qualified institutions for approved purposes in accordance with NPS *Museum Handbook*, Part II, Chapter 5: Outgoing Loans. Institutions must meet accepted museum standards for security, handling, and exhibition of NPS museum objects. Sensitive materials may require additional conditions prior to a loan commitment. Expenses related to loans of museum objects, including shipping and insurance, will normally be assumed by the borrower.

Photographs of museum objects are made available to the public to provide an indirect use of the museum collection through publications and exhibits (including exhibits on the park website). Many of the park's artifacts have been illustrated in publications.

All exhibits containing museum objects must have proper security, appropriate environmental controls, and proper mounts to ensure the long-term preservation and protection of the objects.

VI. RESTRICTIONS

Restrictions in addition to those applying to the use of the museum collection outlined in Section IV of this statement are as follows:

In accordance with NPS *Management Policies* (2001) 7.5.5. "Consultation" and 5.3.5.5 "Museum Collections," and DO #24: NPS Museum Collections Management, curatorial staff should consult with traditionally associated peoples and other cultural and community groups for whom the collection has significance. Archeological objects in the museum collection shall be made available to persons for use in religious rituals or spiritual activities in accordance with 36 CFR 79, Section 79.10(c), "Curation of Federally-owned and Administered Archeological Collections." Requests to borrow non-archeological material for religious ritual or spiritual activities will be addressed on a case-by-case basis.

The park will not approve research on human remains and associated funerary objects without the consent of the affected group(s).

In accordance with the National Historic Preservation Act of 1966, as amended (16 USC 470 et seq.), the Archaeological Resources Protection Act of 1979, as amended (16 USC 470aa-mm), the National Parks Omnibus Management Act of 1998 (16 USC 5937), and NPS *Management Policies* (2001) 4.1.2. "Natural Resource Information" and 5.2.3 "Confidentiality," the park may withhold from the public sensitive information concerning: rare, threatened, or endangered species; commercially valuable resources; minerals; paleontological resources; archeological and other cultural resources; objects of cultural patrimony and sensitive ethnographic information; information provided by individuals who wish the information to remain confidential; the identities of individuals who wish to remain anonymous. Inquiries of this nature will be referred to the regional Freedom of Information Act (FOIA) and Privacy Act Officer for consultation and possible review.

Restrictions may be placed on the publication of images or manuscripts in the museum collection if these materials are subject to copyright, and the National Park Service does not hold the copyright.

Figure E.1. Example Approved Scope Collection Statement (continued)

All endangered, threatened, or rare plants and vertebrate and invertebrate animals will be collected only when accidentally killed or when dead from natural causes. The collection of threatened, endangered, or rare plant and animal species will comply with NPS *Management Policies* (2001), be in accordance with the provisions of the Endangered Species Act of 1973, as amended, and will be strictly limited according to the applicable rules of the U.S. Fish and Wildlife Service.

Final disposition of type specimens will be determined at the Servicewide level and will adhere to recognized conventions established for specific disciplines.

The park will not knowingly be a partner to or encourage in any way the trafficking in illicitly collected materials.

VII. MANAGEMENT ACTIONS

This Scope of Collection Statement must be reviewed every five years, and be revised when necessary, to remain supportive of and consistent with any changes in the park's mission. Any revision to this document requires the approval of the superintendent.

The park has an approved Collection Management Plan. The plan was approved on August 2, 1996.

A number of objects from the collection are housed at repositories outside of the park:

1. 493 nitrate film negatives are stored at the Western Archeological and Conservation Center in Tucson, Arizona.
2. Twenty-nine paleontological specimens are located at Boise State University in Boise, Idaho.
3. Ninety-one mammal specimens (collected at the park in the 1930s and 1950s) are housed at the Utah Museum of Natural History, University of Utah, in Salt Lake City.
4. 200 lichen specimens collected in 1981 are stored at the Utah Museum of Natural History, University of Utah, in Salt Lake City.
5. Fifty-two fungi specimens collected in 1998 are housed at Stanford University, in Stanford, California.

The park staff is compiling data on collections in other institutions that were removed from sites within the park. Natural history collections and archeological materials were removed from sites presently within the park boundaries before its creation in 1928 and during the first two decades of the park's existence. The list of institutions in the United States that have important collections from the park include: the Idaho Museum of Natural History in Pocatello, the Smithsonian Institution, the University of Colorado in Boulder, and the University of Utah in Salt Lake City. These collections still contain a wealth of information that has not been fully analyzed to date.

Recall of objects loaned to the park is a possibility. The park needs to seek replacements for exhibited objects on long-term loan in order to prevent potential disruption of exhibits.

Figure E.1. Example Approved Scope Collection Statement (continued)



National Park Service
U.S. Department of the Interior

Lewis Mountains
National Park

PO Box 100
Bear Valley, Idaho 83301
(208) 555-8142 phone
(208) 555-1767 fax

Lewis Mountains National Park

Scope of Collection Summary

The park's museum collection includes both natural history and cultural collections. The park's natural history collection includes: mammal and bird collections; the herbarium, which includes nearly all species of vascular plants that occur in the park; paleontological collections from the Bear Valley Shale Formation; geological specimens from the Bear Valley Shale and Lewis Granite Formations. Other natural history collections within the museum collection include: fungi; reptiles and amphibians; fish; insects and arachnids. At present, these collections are relatively small, as little research pertaining to these disciplines has been conducted in the park to date.

The cultural collection includes: archeological materials systematically excavated from within the park's boundaries and associated field records (circa 1000 BCE – circa 1940); an ethnology collection of Paiute and Shoshone basketry, watercolors, beadwork, and textiles; historic objects associated with the area's 19th century miners, railroad workers, and homesteaders, and items related to the Civilian Conservation Corps and President Franklin D. Roosevelt's 1938 park vacation; archival and manuscript collections such as the Joseph Jakes papers, oral histories, photographs, and scientific and resource management records.

For additional information on the museum collection contact:

Museum Curator
Lewis Mountains National Park
PO Box 100
Bear Valley, Idaho 83301
(208) 555-8142 phone
(208) 555-1767 fax
lemo_curator@nps.gov

EXPERIENCE YOUR AMERICA

The National Park Service cares for special places saved by the American people so that all may experience our heritage.

Figure E.2. Example Scope of Collection Summary



National Park Service
U.S. Department of the Interior

CHECKLIST FOR EVALUATING SCOPE OF COLLECTION STATEMENTS

Unit's Name: _____

Draft _____ Approved _____ Date: _____

Reviewed by: _____ Date: _____

	Name	Title	YES	NO	NA	Note*
A. Does the SOCS have TITLE PAGE?			_____	_____	_____	_____
1. Is Title Page format correct?			_____	_____	_____	_____
2. Does Title Page include all required signatures and dates?			_____	_____	_____	_____
B. Does the SOCS have INTRODUCTION section?			_____	_____	_____	_____
1. Does SOCS have an Executive Summary?			_____	_____	_____	_____
2. Is purpose of SOCS stated?			_____	_____	_____	_____
3. Are NPS legal authorities (laws) to acquire and preserve museum objects cited?			_____	_____	_____	_____
4. a. Is unit's mission stated?			_____	_____	_____	_____
b. Is unit's enabling legislation cited?			_____	_____	_____	_____
c. If applicable, is subsequent legislation cited?			_____	_____	_____	_____
5. If applicable, is there a statement indicating that a museum collection is mandated by the unit's enabling or subsequent legislation?			_____	_____	_____	_____
6. Unit's Interpretive Themes:						
a. Are interpretive themes listed?			_____	_____	_____	_____
b. Are interpretive periods listed?			_____	_____	_____	_____
c. If available, are appropriate planning documents (title/date) cited?			_____	_____	_____	_____
7. Unit's Resource Management Goals and Objectives:						
a. Are pertinent cultural and natural resource management goals and objectives listed?			_____	_____	_____	_____
b. Are planning documents (title/date) cited?			_____	_____	_____	_____
8. Mandated Collections:						
a. Is statement, citing 43 CFR 7.13 and NPS <i>Management Policies</i> (2001), made that archeological collections are managed as part of the unit's museum collection?			_____	_____	_____	_____
b. Is there a statement citing permit conditions and curatorial requirements pertaining to 36 CFR 2.5g?			_____	_____	_____	_____
9. Is there a discussion of the significance and history of the collection?			_____	_____	_____	_____

*See additional notes pertaining to this question on attached pages.

Page 1 of 5

Figure E.3. Checklist for Evaluating Scope of Collection Statements

	<u>YES</u>	<u>NO</u>	<u>NA</u>	<u>Note*</u>
10. Are other laws, regulations, conventions, and special directives relevant to acquisition of museum objects cited?	_____	_____	_____	_____
11. If applicable, are any special unit designations (e.g., Biosphere Reserve, National Historic Landmark, World Heritage Site) that may be pertinent to museum collection cited?	_____	_____	_____	_____
C. Does the SOCS have TYPES OF COLLECTIONS section?	_____	_____	_____	_____
1. Is there a brief profile of the unit's museum collection?	_____	_____	_____	_____
2. Is there an introductory statement indicating that the INTRODUCTION section states the purpose of collection?	_____	_____	_____	_____
3. Is section divided into two major categories: Natural History Collection and Cultural Collection?	_____	_____	_____	_____
4. Natural History Collection Category:				
a. If appropriate, is there a statement that the unit does not collect/maintain a natural history collection for its own purposes?	_____	_____	_____	_____
b. If unit collects/maintains a natural history collection is there an introductory paragraph that briefly outlines the purpose of this collection?	_____	_____	_____	_____
c. Is major category subdivided into disciplines (Biology, Geology, Paleontology) pertinent to unit?	_____	_____	_____	_____
d. Is each discipline subdivided into collecting categories that reflect unit's purpose for collection?	_____	_____	_____	_____
e. If appropriate, under each collecting category:				
1) Is current representation of object types described?	_____	_____	_____	_____
2) Are priorities established to fill identified deficiencies (gaps) in existing collection?	_____	_____	_____	_____
3) Are limits (quantities) defined?	_____	_____	_____	_____
f. Is there a collecting category for "associated records" under each discipline?	_____	_____	_____	_____
g. Does paleontology discipline include a statement relevant to uncontrolled surface collecting?	_____	_____	_____	_____
5. Cultural Collection Category:				
a. Does introductory paragraph include a statement that describes the purpose of this collection?	_____	_____	_____	_____
*See additional notes pertaining to this question on attached pages.				
NPS Checklist for Evaluating Scope of Collection Statements				Page 2 of 5

Figure E.3. Checklist for Evaluating Scope of Collection Statements (continued)

	<u>YES</u>	<u>NO</u>	<u>NA</u>	<u>Note*</u>
b. Does introductory paragraph state that an object or archival/manuscript collection from site or directly associated to person(s) or event(s) commemorated by the unit is more desirable than a similar object without such primary association?	_____	_____	_____	_____
c. Is major category subdivided into disciplines pertinent to the unit (Archeology, Ethnology, History, Archives)?	_____	_____	_____	_____
d. Is each discipline subdivided into collecting categories that reflect the unit's purpose for collection?	_____	_____	_____	_____
e. If appropriate, under each collecting category:				
1) Is current representation of object or archival types described?	_____	_____	_____	_____
2) Are priorities established to fill identified deficiencies (gaps) in existing collection?	_____	_____	_____	_____
3) Are limits (quantities) defined?	_____	_____	_____	_____
f. Does archeology discipline include collecting categories for "artifacts and specimens" and "associated records"?	_____	_____	_____	_____
g. Does archeology discipline include a statement relevant to uncontrolled surface collecting?	_____	_____	_____	_____
D. Does the SOCS have MUSEUM COLLECTIONS SUBJECT TO THE NATIVE AMERICAN GRAVES PROTECTION & REPATRIATION ACT OF 1990 section?	_____	_____	_____	_____
1. Does section contain appropriate statement regarding the required summary of unassociated funerary objects, sacred objects, and objects of cultural patrimony?	_____	_____	_____	_____
2. Does section contain appropriate statement regarding the required inventory of human remains and associated funerary objects?	_____	_____	_____	_____
E. Does the SOCS have ACQUISITION section?	_____	_____	_____	_____
1. Is there a statement describing types of potential acquisition sources?	_____	_____	_____	_____
2. Does section include statement that acquisition of objects is governed by the unit's capability to preserve its museum collection in accordance with NPS <i>Management Policies</i> (2001), DO #28, and the NPS <i>Museum Handbook</i> , Part I?	_____	_____	_____	_____
3. Is there a statement that prohibits gifts with restrictions or limiting conditions?	_____	_____	_____	_____
*See additional notes pertaining to this question on attached pages.				
NPS Checklist for Evaluating Scope of Collection Statements				Page 3 of 5

Figure E.3. Checklist for Evaluating Scope of Collection Statements (continued)

	<u>YES</u>	<u>NO</u>	<u>NA</u>	<u>Note*</u>
4. Does section state that acquisition of firearms included on the Bureau of Alcohol, Tobacco, & Firearms (ATF) list of prohibited and restricted weapons requires concurrent review prior to acceptance by regional/SO curator and regional/SO law enforcement specialist?	_____	_____	_____	_____
5. Does section state that museum objects must be acquired, accessioned, and cataloged in accordance with NPS <i>Museum Handbook</i> , Part II?	_____	_____	_____	_____
6. Is there a statement regarding delegation of authority to the unit's superintendent to accept title to and responsibility for museum collections?	_____	_____	_____	_____
7. Does this section outline any park-specific acquisition procedures that supplement NPS policies?	_____	_____	_____	_____
F. Does the SOCS have USES OF COLLECTIONS section?	_____	_____	_____	_____
1. Is there a description of desired and acceptable uses?	_____	_____	_____	_____
2. Is there a statement regarding conservation as a primary consideration when determining uses?	_____	_____	_____	_____
3. In accordance with the NPS <i>Management Policies</i> (2001), Chapter 7, does section state that unit shall not place skeletal or mummified human remains, photographs of skeletal or mummified human remains, grave goods, or other objects considered sacred on display?	_____	_____	_____	_____
4. Is there a statement regarding access to museum collection?	_____	_____	_____	_____
5. Does section reference DO-24, DO-28, and DO-6 relevant to potentially consumptive uses of museum objects?	_____	_____	_____	_____
6. Does section reference DO-24, DO-28, and <i>Cultural Resource Management Guideline</i> relevant to research/destructive analysis of museum objects?	_____	_____	_____	_____
G. Does the SOCS have RESTRICTIONS section?	_____	_____	_____	_____
1. Does section include a statement regarding consultation with tribal governments, Native Hawaiian organizations, Alaskan Native Corporations, and traditional religious leaders?	_____	_____	_____	_____
2. Does section state NPS policy relevant to disclosure of information on location, nature, and character of cultural resources?	_____	_____	_____	_____
*See additional notes pertaining to this question on attached pages.				
NPS Checklist for Evaluating Scope of Collection Statements				Page 4 of 5

Figure E.3. Checklist for Evaluating Scope of Collection Statements (continued)

	<u>YES</u>	<u>NO</u>	<u>NA</u>	<u>Note*</u>
3. Does section state NPS policy relevant to keeping confidential identities of community consultants and information about sacred and other culturally sensitive places and practices?	_____	_____	_____	_____
4. Is there a statement regarding use of objects subject to copyright?	_____	_____	_____	_____
5. If appropriate, is there a statement relevant to the collecting of endangered, threatened, or rare species?	_____	_____	_____	_____
6. Is there a statement concerning the disposition of type specimens?	_____	_____	_____	_____
7. Does section identify any legal restrictions on disposition or uses of the unit's museum collection?	_____	_____	_____	_____
H. Does the SOCS have a MANAGEMENT ACTIONS section?	_____	_____	_____	_____
1. Are there statements that require the following:				
a. Periodic review of SOCS?	_____	_____	_____	_____
b. SOCS remains supportive of and consistent with unit's mission?	_____	_____	_____	_____
c. Unit superintendent's approval of any revisions to SOCS?	_____	_____	_____	_____
2. Does section document existence of or need for a Collection Management Plan?	_____	_____	_____	_____
3. If any collections are located outside the unit's boundaries, is a brief description of each collection and name and location of each repository identified?	_____	_____	_____	_____
I. Comments/Recommendations (If needed, attach additional pages.):				
_____ See attached copy of unit's approved or draft Scope of Collection Statement for editorial comments.				
_____ Revise the SOCS to correct the deficiencies noted on this checklist. See <i>NPS Museum Handbook</i> , Part I, (<i>MH-I</i>) Chapter 2, Scope of Museum Collections (2003), Sections D-J, for guidance on writing a Scope of Collection Statement. You can also consult the sample Scope of Collection Statement in <i>MH-I</i> , Appendix E, Scope of Collection Statement (2003) for additional assistance.				
_____ See additional notes on attached pages.				
*See additional notes pertaining to this question on attached pages.				
NPS Checklist for Evaluating Scope of Collection Statements				Page 5 of 5

Figure E.3. Checklist for Evaluating Scope of Collection Statements (continued)

Appendix F: NPS Museum Collections Management Checklists

A. Overview	F:1
B: NPS Checklist for Preservation and Protection of Museum Collections	F:1
What is the purpose of the Checklist?	F:2
What additional tools do I need to address the ongoing (day-to-day) needs of the museum collection?	F:2
How do I complete the Checklist?.....	F:2
What data do I collect and record with the Checklist?.....	F:3
How are NPS preservation and protection standards reflected in the Checklist?	F:3
How is the Checklist organized?	F:4
How do I determine costs for correcting deficiencies identified in the Checklist?.....	F:4
How do I use the information in the Checklist?.....	F:5
How is the Checklist used for GPRA?	F:5
Who else uses the information in the Checklist?	F:5
C. NPS Collection Management Plan Team Site Visit Checklist	F:6
D. NPS Collection Management Plan Team Reference Document Checklist	F:24
E. List of Figures	F:27

APPENDIX F: NPS MUSEUM COLLECTIONS MANAGEMENT CHECKLISTS

A. Overview

This appendix includes three Checklists that support the preservation of NPS collections.

- NPS Checklist for Preservation and Protection of Museum Collections
- NPS Collection Management Plan Team Site Visit Checklist
- NPS Collection Management Plan Team Reference Document Checklist

The NPS Checklist for Preservation and Protection of Museum Collections is submitted using the Automated Checklist Program (ACP) in the Automated National Catalog System (ANCS+). This Checklist is the responsibility of park museum employees. The information in Figure F.1 will assist you in estimating costs to correct deficiencies identified in the checklist.

The 1996 manual version of the Checklist (before it was incorporated into ANCS+) is in Figure F.2. This version is provided for easy reference to Checklist questions. Though the ACP questions are identical, the ACP allows you to track additional information. Parks and centers must submit their Checklist using the ACP.

The other two checklists (Sections C and D) in this Appendix are used by Collection Management Plan (CMP) teams and serve as outlines for the information that the CMP team collects, reviews, and distributes.

B. NPS Checklist for Preservation and Protection of Museum Collections

The NPS Checklist for Preservation and Protection of Museum Collections (Checklist) has gone through several revisions. It was first issued in 1986 as the Inspection Checklist for Museum Storage and Exhibit Spaces. The Department of the Interior adopted the checklist and in 1992 the NPS used a version entitled the DOI Checklist for the Preservation, Protection and Documentation of Museum Property, Part I: Preservation and Protection of Museum Property (as amended for use by the National Park Service, February 28, 1992). In 1996 it was automated in a DOS-based computer program and submitted by parks in electronic format for the first time. At that time it assumed its current name and the automated program was called the Automated Checklist Program (ACP). Since the issuance of ANCS+ in 1998, the Checklist is submitted using the Windows-based ACP, a utility in ANCS+.

1. *What is the purpose of the Checklist?*

Each unit (park, center, or office) is required to conduct a self-assessment in order to update progress on how well it is preserving and protecting the museum collections in its custody. The Checklist is designed as a tool to facilitate this self-assessment. It will assist you in identifying the preservation and protection needs of your unit's museum collection. The Checklist can help your unit to obtain funding from the servicewide Museum Collections Preservation and Protection Program (MCP) and other funding sources to correct deficiencies in your:

- facilities
- equipment
- supplies
- planning

You also use the Checklist to report accomplishments regarding NPS Strategic Plan Goal Ia6 for the Government Performance and Results Act (GPRA).

2. *What additional tools do I need to address the ongoing (day-to-day) needs of the museum collection?*

The Checklist provides some data on managing the preservation of museum collections, but does not address all of the needs (including staffing) of your museum collection. The daily responsibilities include accessioning, cataloging, and inventorying; housekeeping; monitoring and controlling the environment and pests; storage; security; fire protection; conservation treatment; access; research; publication; and exhibits (both traditional and Web-based).

In addition to the Checklist, you need to use other planning and budgeting tools to identify the total base funding needs of the collection:

- Collection Management Plan (CMP)
- Resources Management Plan (RMP)
- Resources Management Assessment Program (R-MAP) – includes Natural Resources and Cultural Resources
- Performance Management Information System (PMIS)
- Operations Formulation System (OFS) – documents funding and staffing needs

3. *How do I complete the Checklist?*

To complete the Checklist you must use the Automated Checklist Program (ACP) included in the ANCS+ collection management package. The ACP generates the Checklist for your park, center, or office. Instructions for completing the Checklist using the ACP are in Appendix G: The Automated Checklist Program of the *ANCS+ User Manual* issued in 1998. The *ANCS+ User Manual* is issued to each park and center with ANCS+. You can download extra copies of the manual from the Museum Management Program website at <www.cr.nps.gov/museum/publications/ancs.html>.

4. *What data do I collect and record with the Checklist?*

The Checklist identifies basic preservation and protection deficiencies when you answer a list of questions for each facility in your unit.

A **unit** is defined as a park, center, or office with museum collections. You answer one group of questions (Section H. Professional Assistance and Museum Planning) just for the unit.

A **facility** is defined as a space that houses museum collections, for example, a visitor center, rooms in a historic structure, a barn, or park headquarters. A single building can have more than one facility (or space) where museum objects are located. For example, the exhibit area, the storage room, and the administrative office that houses museum objects or archives could each be a separate facility within one building.

You must answer “YES” or “NO” or “NOT APPLICABLE” to each question and record the following information where appropriate:

- description of the deficiency
- cost estimate to correct the deficiency
- description of the action that will be taken to correct the deficiency
- comments
- funding spent in the previous fiscal year
- previous estimates for cost that have been recorded in the Checklist
- percentage of the deficiency that has been corrected, if not complete

5. *How are NPS preservation and protection standards reflected in the Checklist?*

The NPS standards, or basic requirements, for managing museum collections are represented by each question in the Checklist. You complete this self-assessment to determine which standards your park meets. If the unit does not meet a standard (that is, you answer “NO” on the Checklist), then the unit has a deficiency for that standard. The Checklist has standards in eight categories:

- Administrative offices
- Museum collections storage
- Exhibits
- Museum environment
- Security
- Fire protection
- Housekeeping
- Professional assistance and museum planning

6. *How is the Checklist organized?*

The standards under each category (except professional assistance and museum planning) are organized under the following sub-categories:

- Operations (procedural)
- Museum facility
- Equipment and supplies

You will answer different questions on the Checklist depending on the type of facility (Unit, Administrative, Storage, or Exhibit). These questions will come up automatically in the ACP.

<i>If type of space is . . .</i>	<i>Then . . .</i>
Unit	answer Section H. Professional Assistance and Museum Planning
Administrative	answer Section A. Administrative Offices
Storage	answer Sections B. Museum Collection Storage D. Museum Environment E. Security F. Fire Protection G. Housekeeping
Exhibit	answer Sections C. Exhibits D. Museum Environment E. Security F. Fire Protection G. Housekeeping

7. *How do I determine costs for correcting deficiencies identified in the Checklist?*

The information in Figure F.1 will assist you in estimating costs to correct deficiencies identified in the Checklist. All categories and subcategories in the table correspond to the Checklist. The costs shown are average costs that may be increased or decreased in your cost estimates depending on your unit's needs and geographic location.

With two exceptions, you must correct all deficiencies listed under the sub-category "Operations (procedural)" with base funding. Procedural deficiencies have minimal cost and can be corrected with changes in procedures. The two exceptions are under Category E, Security, question 1 (key issuance) and question 8 (Emergency Operation Plan).

Consult with park maintenance and protection staff as well as the regional/SO curator for assistance with estimating costs. If numerous deficiencies are identified, it may be necessary to rehabilitate an existing facility or to construct a new facility. Review programming documents for cost estimates. Look at documents such as the Project Management Information System (PMIS) projects and plans for new construction and repair/rehabilitation of museum collection storage and exhibit facilities.

Prices of equipment and supplies don't include shipping. Units should contact vendors for estimates of shipping to the site. Pricing, except where covered by contracts, is approximate and based on current prices from a range of acceptable models, types, or materials from several vendors. Refer to the NPS *Tools of the Trade* for descriptions and vendor sources of equipment and supplies.

Estimates should be calculated and as close to the real cost as possible. These estimates are important. Servicewide plans and long-range programming and budgeting are based on these data.

8. *How do I use the information in the Checklist?*

Use the reports generated in the Checklist to help you plan improvements to the preservation and protection of your museum collections. As you carry out projects that remove the deficiencies on the Checklist, you will:

- improve the care given to the collections
- meet NPS museum standards
- ensure the continued survival and accessibility of NPS collections
- enhance access and use of NPS museum collections

9. *How is the Checklist used for GPRA?*

The NPS has developed a Servicewide Strategic Plan in response to the Government Performance and Results Act (GPRA). Your park also has a Strategic Plan. The NPS tracks annual performance on the goals in these plans. Goal Ia6, "X% of preservation and protection conditions in park collections meet professional standards," uses Checklist data to track performance.

10. *Who else uses the information in the Checklist?*

The Museum Management Program (MMP) and regional and support offices use the information to:

- track conditions in spaces housing collections at servicewide, regional, cluster, and park levels
- measure strategic plan progress for GPRA goal Ia6
- help determine servicewide funding distributions for correcting identified deficiencies
- prepare budget justifications and develop funding requests
- prepare reports for park, cluster, and regional management; the Director, the Department of the Interior, Congress, and public inquiries

Regional and support offices may collect information from parks to help them organize more local strategies for support and funding.

C. NPS Collection Management Plan Team Site Visit Checklist

A Collection Management Plan is one of the primary planning documents for park museum collections. Each park must have a CMP. A CMP assesses a park's museum collection management program to identify problems and makes recommendations to improve the care of the collection.

When a Collection Management Plan (CMP) team visits your site, it will consider a wide range of topics in evaluating your museum program. The checklist in this section provides a detailed outline of a typical CMP. The broad categories may include:

- history of park and museum collection
- scope of collection
- documentation, including records and information management systems
- archival and manuscript collections
- security
- environment
- storage
- exhibits
- housekeeping and cyclic maintenance
- access and use
- staffing
- planning, programming, and funding

Under each category the checklist provides details of the types of topics that may be addressed by the team members. Each park and its museum collections are unique. The topics and depth of detail addressed in each park's CMP depends on the size, content, and condition of the museum and archival collections.

The checklist may be provided to the park staff in advance of the CMP team's visit to the park. It serves to orient the park superintendent and staff on the types and depth of information that the team will require when preparing a plan that will be useful to the park. The team members use the

checklist as a reminder of topics to cover.

A CMP team may include a variety of professionals depending on the types of collections in the park. Types of professionals who may be on a CMP team include:

- Archeologists
- Archival specialists and technicians
- Archivists
- Collections managers
- Conservators
- Curators
- Historians
- Natural scientists
- Registrars
- Security specialists
- Structure fire management specialists

See Chapter 3: Preservation: Getting Started, for more information on the CMP process and how the CMP relates to the Collection Condition Survey (CCS). See *Museum Handbook*, Part II, Appendix D: Museum Archives and Manuscript Collections, for guidance on incorporating a collection-level survey description of your archival materials into a CMP.

**NATIONAL PARK SERVICE
COLLECTION MANAGEMENT PLAN (CMP) TEAM
SITE VISIT CHECKLIST**

I. HISTORY OF PARK AND MUSEUM AND ARCHIVAL COLLECTION

- Enabling legislation/authorization
- Purpose of site/park
- Cultural and natural significance of park
- Provenance/source of collection
- Significance of collection and relationship to the park
- Size of collection
 - Numbers and types of objects and specimens in collection
 - disciplines
 - object classifications
 - Number and types of archival collections
 - total number of separate archival collections (by provenance)
 - linear feet of records
 - types of documents (electronic? photos? films? audio/videotapes?)
 - inclusive dates of archival collections
- Visitation
 - Recent visitor statistics
 - Peak season/time
 - Visitor impact on collection (annual statistics)
 - number of duplicates provided
 - number of research requests (NPS and external) from Collections Management Report
 - number of research room visits (individual visits), if available
 - number of research room visitors (distinct visitors as opposed to visits), if available
 - number of publications, exhibitions, interpretive sessions, films, etc. produced using collections, if available
 - number of FOIA requests

II. SCOPE OF COLLECTION

- Review the Scope of Collection Statement by theme, types of materials, historical era, and geographical coverage to ensure it covers all necessary materials. (Use NPS Checklist for Evaluating Scope of Collection Statements. See Appendix E: Scope of Collection Statement.)
- Acquisition strategies
- Gaps in collection by theme, type of material, association, historical era, geographical coverage
 - Collections development strategy (cooperative acquisition planning with other local/national organizations)
 - Priorities for collecting

- Status of records management program in park
- Disposition strategies
 - Objects outside scope of collection
 - Deaccession proposal(s)
 - Status of official records disposition, if relevant to collections
- Identification strategies for park collections held outside the NPS
 - Where managed
 - How managed—preservation, arrangement, description, and access issues

III. MUSEUM DOCUMENTATION (RECORDS AND INFORMATION MANAGEMENT)

- Records storage and preservation
 - Fire-rated, insulated file cabinet with lock
 - load limitation
 - need for back-up
 - Magnetic media safes, files, boxes
 - floor load
 - need for back-up
 - refreshing/migration needs
 - Location
 - physical and intellectual access
 - sensitive data
 - vital records security
 - Acid-free photocopies of one-of-a-kind records
 - Use of high-quality storage materials
 - Condition
 - reformatting needs
 - other treatment needs
- Accession records
 - Accession Book
 - first and last entries/dates
 - consecutive entries and pages
 - catalog numbers
 - received from/how acquired
 - recording of multiple objects in single accession
 - Accession folders
 - proof of ownership (title documents and physical custody documentation)
 - correspondence on acquisition

- ___ correspondence on donor and legal restrictions, including copyrights, privacy, and publicity rights
- ___ correspondence on consultations with affiliated groups relating to potential cultural sensitivities
- ___ model releases, interview releases, permissions, and licenses relating to accessions
- ___ checklist
- ___ Accession Receiving Report (Form 10-95)

- ___ Source of accession file (optional)

- ___ Unaccessioned objects
 - ___ Number and type
 - ___ Official/non-official, active/inactive records

- ___ Catalog records
 - ___ Copies
 - ___ electronic copy for National Catalog submission
 - ___ blue "working copies" in post binders (optional)
 - ___ classification and location files (optional)
 - ___ first and last catalog records (number/dates)
 - ___ backup copy of ANCS+ data stored off-site
 - ___ Registration and catalog data in ANCS+
 - ___ all mandatory data complete and accurate
 - ___ classifications correct
 - ___ descriptions sufficiently detailed
 - ___ condition indicated and current
 - ___ locations current
 - ___ values current and updated periodically
 - ___ ANCS+
 - ___ percent of collection in ANCS+
 - ___ type of equipment
 - ___ Retrievability of objects and information
 - ___ objects marked with catalog numbers correctly
 - ___ acronyms used
 - ___ NH labels
 - ___ Cataloging backlog
 - ___ number and type of objects (available on CMR)
 - ___ Catalog folders or ANCS+ supplemental records
 - ___ condition reports
 - ___ object treatment requests and reports
 - ___ appraisals
 - ___ research information
 - ___ restrictions
 - ___ routine maintenance
 - ___ location, status, and catalog history

- ___ Inventory records
 - ___ 100% inventory, if applicable

- ___ Automated Inventory Program
 - ___ Random Sample Inventory
 - ___ Controlled Property Inventory
 - ___ Accessions Inventory
- ___ Missing objects
 - ___ Report of Survey (DI-103)
- ___ Collections Management Report
 - ___ Accurate
 - ___ Center records included
 - ___ Non-NPS repository records included
 - ___ Loans included and accurate
- ___ Loan records
 - ___ Incoming (number, location, and renewal)
 - ___ Outgoing (number, location, and renewal)
 - ___ Loan agreements
 - ___ Loan folders and files
 - ___ Loan tracking
- ___ Deaccessions
 - ___ Number and type
 - ___ Disposition documents
- ___ Photographs
 - ___ Object photos
 - ___ room/exhibit installation photos
 - ___ record photos
 - ___ digital photos in ANCS+

IV. ARCHIVAL AND MANUSCRIPT COLLECTIONS

___ Archival collecting history

___ Synopsis should include:

___ When and why archival and manuscript collecting began

___ The focus (thematic, temporal, and geographic) of early archival collecting

___ Names and titles of major records/archival manuscript collection creators/collectors

___ The history of records management in the park, if known

___ An abstract of the park archival and manuscript collections at the repository level, including:

___ number of separate archival/manuscript collections

___ number of collections with finding aids

___ number of collections cataloged at the archival collection level in ANCS+

___ inclusive dates of total archival holdings

___ volume of total archival holdings

___ major types and estimates of quantities of materials included (e.g., photographs, architectural drawings, sound and video recordings, maps, electronic media, and manuscripts)

___ brief description of any exceptionally significant groups of materials

___ major gaps in archival collections, if known (e.g., nothing on a particular era, theme, region, group, or entire categories of records, for example, diaries, maps, or photos)

___ identification of the various buildings and spaces containing archival materials

___ determination of whether an Archival Assessment has been done (all archival and manuscript collections and park records have been surveyed and described at the collection level with recommendations)

___ attached copy of any archival assessment or other collection-level survey of park records and manuscripts

___ Records management

___ Does the park have the following:

___ a clear file plan

___ trained records management staff

___ all official records located and labeled with clear disposition plan (to NARA) and cut-off dates

___ all inactive non-official records located, compared to the SOCS, and materials for the museum collections transferred and cataloged or disposed of appropriately

___ Procedures

___ Archival processing plan indicating:

___ prioritized lists of collections for arrangement, description, preservation, reformatting, and finding aid work

___ documentation on major collection risks (preservation, legal, and theft/vandalism)

___ definition of resource (staffing, supply, and funding) needs

___ staff training needs

___ archival storage, work, and reference room improvements necessary

___ steps necessary to achieve better access to collections

___ Processing guidance including standard operating procedures for:

___ archival collection preservation

- ___ archival handling
- ___ archival rehousing and storage
- ___ archival reformatting and/or treatment
- ___ archival description and cataloging (including ANCS+ cataloging and description in Collections Management and Archives Module):
 - ___ descriptive rules (archives, personal papers, and manuscripts),
 - ___ descriptive format (MARC format)
 - ___ vocabularies (Library of Congress Subject Headings and AAT)
 - ___ personal and corporate names (Library of Congress name authorities)
- ___ finding aid and guide creation, indexing, and production procedures
- ___ procedures for mounting finding aids on Web
- ___ procedures for sending guides and finding aids to National Union Catalog of Manuscript Collections (NUCMC).
- ___ archival arrangement, including
 - ___ preparatory research work
 - ___ identification of provenance and original order,
 - ___ identification of restrictions
 - ___ how to identify and arrange series
 - ___ how to identify and arrange file units
 - ___ when and how to weed
 - ___ how to resolve problems

- ___ A collections documentation strategy identifying any gaps in collections and indicating how they will be filled

___ Access and use

- ___ Catalog records at the archival collection-level in ANCS+ Collections Management System
- ___ Collections processed (arranged and described) by a professional archivist
- ___ Major collections cataloged within the ANCS+ Archives Module at the series and/or file unit and/or item-level.
- ___ Item level records linked to an appropriate collection-level record in the ANCS+ Collections Management System
- ___ Indexed finding aids for each archival or manuscript collection in the park
- ___ Master guide to all collections with a single index to names, subjects, and formats (document types)
- ___ Entries in the NUCMC on park collections

___ Equipment

- ___ On-site freezer, or off-site storage for nitrate film
- ___ Book trucks to transfer materials to research room

V. MUSEUM SECURITY (Use Survey Checklist) See Chapter 9:“Security and Fire Protection” and Appendix G: “Museum Collections Protection.”

- Procedures
- Risk assessments
- Physical and electronic security
- Fire prevention, detection, and suppression
- Emergency management, planning, and response

VI. MUSEUM ENVIRONMENT

- Temperature and relative humidity
 - Local climate
 - mean/extreme temperature and RH
 - frost season
 - annual precipitation
 - Measurements
 - room-by-room
 - outside
 - past logs/charts and analyses
 - Equipment
 - psychrometer (sling/aspirating)
 - hygrothermographs
 - dial thermohygrometers
 - dataloggers
 - calibration frequency
 - Climate control
 - HVAC system (type and location of air handlers, vents)
 - portable humidifiers and dehumidifiers (location and number)
- Light
 - Measurements (seasonal)
 - ultraviolet
 - visible
 - Light sources
 - natural (doors, windows)
 - artificial (fluorescent, incandescent)
 - Protection
 - UV-filtering film on windows
 - UV sleeves on fluorescent lights
 - curtains, shades, shutters
- Dust and air pollution

- ___ Local air pollution levels
 - ___ monitoring in park (by EPA or other agency)

- ___ Source of dust air pollution
 - ___ highways
 - ___ industry
 - ___ unexcavated basement
 - ___ asbestos containing materials in building
 - ___ visitors

- ___ Air filtration/purification system
 - ___ HEPA filter
 - ___ activated charcoal filters
 - ___ portable air purifiers

- ___ Protective measures
 - ___ entrance mats
 - ___ weather-stripping

- ___ Biological infestation
 - ___ Past infestation
 - ___ pests identified (insects, birds and mammals, mold)
 - ___ action taken
 - ___ damage to collection
 - ___ evidence of current infestation (frass and droppings, tunnels and holes, nests, mold)
 - ___ staging area and freezer for dealing with infested materials

 - ___ Park IPM Program
 - ___ park IPM Coordinator involvement with museum collections
 - ___ monitoring program
 - ___ periodic inspections
 - ___ written log and analyses

 - ___ Potential attraction and harborage sites
 - ___ kitchen (food storage)
 - ___ appliances
 - ___ plumbing/water source
 - ___ cracks and gaps
 - ___ trash removal (overnight)

 - ___ Pesticides
 - ___ unauthorized use of any pesticide
 - ___ potential hazards from past pesticide use

- ___ Hazardous materials and response
 - ___ Labeled hazards
 - ___ cellulose nitrate film
 - ___ collections with pesticide residues
 - ___ firearms, armaments, edged weapons, ammunition
 - ___ medical, dental, veterinary equipment
 - ___ heavy metals in textiles
 - ___ hazardous rocks/fossils
 - ___ radiation

- toxic materials used in construction of objects
- asbestos
- flammable supplies
- moldy materials
- pest residues

- Safety equipment
 - rated breathing apparatus, for mold, hantavirus and asbestos fitted to staff who need them
 - smocks, neoprene gloves, goggles

VII. STORAGE

- Existing storage condition
 - Location of storage
 - hazardous location (fault line, cliff, near water, near highway)
 - attic
 - basement
 - water pipes/roof leaks/open water source overhead/storm drain in or above space
 - available space (square footage)
 - 10 year expansion needs
 - additional space needed for current collection (compactor system, superinsulated building)
 - load limitations
 - space utilization (aisle widths, cabinet arrangement)
 - multiple building use
 - off-site storage
 - collections split, consider all locations

 - Dedicated storage
 - non-museum items or functions that don't belong in collections storage
 - restricted access

 - Exclusively curatorial functions
 - percent of collection in storage
 - type of museum objects
 - organization of storage (by material, provenience or object type)
 - range in size of objects stored

 - Storage equipment
 - number of cabinets/shelves
 - type of cabinets/shelves
 - standard/double specimen cabinets
 - wardrobe/jumbo GL-C cabinets
 - visual storage cabinets
 - entomology cabinets
 - herbarium cabinets
 - map cabinets
 - security gun vaults
 - art storage racks
 - mobile shelving-either bakers rack or installed
 - fire-insulated file cabinets
 - steel shelving
 - equipment needed
 - condition of cabinet gaskets seals
 - cabinet locks

- ___ Storage methods
 - ___ stored correctly using proper equipment
 - ___ elevated off floor >4"
 - ___ polyethylene drawer liners/shelf pads
 - ___ polyethylene foam cavity packing
 - ___ stacking/crowding
 - ___ dust covers made of stable materials, where appropriate
 - ___ labels

- ___ Curatorial workspace
 - ___ separate from storage area
 - ___ examining table
 - ___ other equipment
 - ___ no food or open water sources

- ___ Research room
 - ___ separate from storage and curatorial work areas
 - ___ totally and easily visible from the curatorial work space
 - ___ lockers or coat rack and storage space nearby
 - ___ ANCS+ terminal available
 - ___ adequate space
 - ___ good lighting at low levels using incandescent spot lights
 - ___ stable environment similar to storage space
 - ___ continuous staff supervision during operation

- ___ Off-site storage
 - ___ leased space for park collections
 - ___ regional NPS repositories
 - ___ non-NPS repositories (documented loans)
 - ___ cellulose nitrate and cellulose ester cold storage

- ___ Condition of objects, archival and manuscript materials and specimens in storage
 - ___ Collection Condition Survey needed

 - ___ Storage materials
 - ___ inert, archival quality
 - ___ acid-free, buffered or unbuffered
 - ___ cabinets vs. shelves
 - ___ specimen trays
 - ___ padding

 - ___ Periodic inspection for deterioration
 - ___ frequency
 - ___ evidence of deterioration
 - ___ conservation treatment needed
 - ___ reformatting and retirement or treatment of original

 - ___ Proper storage to maintain condition
 - ___ archeological bulk collections
 - ___ baskets
 - ___ books
 - ___ ceramics and glass
 - ___ costumes
 - ___ electronic records

- entomology specimens
- firearms
- fossils
- freeze-dried/taxidermy specimens
- furniture
- herbarium specimens
- manuscripts and archival textual materials
- magnetic media
- maps
- metals
- motion picture film
- paintings and framed graphics
- phonograph records
- photographic images
- skins
- textiles
- unframed graphics
- wagons, carriages, canoes
- wet specimens
- other

VIII. EXHIBITS

- Evaluation of collection use in exhibits
- Existing exhibit conditions
 - Locations
 - visitor center
 - other exhibits
 - Furnished historic structures
 - approved historic furnishing report
 - tour arrangements (average group size, guided/self-guided)
 - placement of objects away from vents/light and potential handling/touching
 - Exhibit cases and construction
 - UV glass or Plexiglas
 - UV shields on lights
 - inert materials
 - curatorial access
 - security (tamper-free)
 - air tight (gasket seals)
 - object mounts
 - Exhibit lighting
 - low-voltage, cool lights (see also Museum and Archival Environment)
 - Exhibit maintenance manual
 - Rehabilitation needed
- Condition of objects on exhibit
 - Collection Condition Survey needed

- Neutral barriers between objects of dissimilar materials (Mylar, acid-free matboard)
- Neutral barriers between objects and audience
- Park procedures limiting smoking, eating, and receptions in exhibit spaces
- Evidence of deterioration
 - conservation treatment needed
 - weekly/daily inspections
 - objects that should not be exhibited
- Exhibit maintenance
 - manuscripts and books (rotated/turned - copies used where possible)
 - textiles and costumes (refolded/rotated)
 - wood furniture (waxed)
 - silver (polished or lacquered)
 - iron and steel (microcrystalline wax)
 - other
- Reproductions
 - cataloged
 - substituted for fragile original in exhibits and for reference
- Objects accessible for visitors to touch
 - consumptive use approved

IX. HOUSEKEEPING AND CYCLIC MAINTENANCE

- Existing conditions
 - Dust
 - Clutter
- Written housekeeping manual
 - Cleaning methods
 - Cleaning materials
 - Schedule (documented in ANCS+ Maintenance Module)
- Equipment
 - Vacuums (HEPA, backpack, portable)
 - Other equipment and supplies
- Proper handling of museum and archival objects
- Cyclic preventive building maintenance
 - Maintenance Management System (Facility Management Software system, effective FY2000)

- ___ Personnel
 - ___ Maintenance staff (supervisor)
 - ___ Curatorial staff
 - ___ Training in curatorial housekeeping
- ___ Storage of cleaning supplies and equipment

X. ACCESS AND USE

- ___ Procedures for evaluating museum collections use
 - ___ Forms
 - ___ access procedures and rules governing use statement
 - ___ researcher registration form
 - ___ copyright and privacy restrictions statement
 - ___ researcher duplication form
 - ___ researcher log
 - ___ Checklist: Evaluating a Request to Use Museum Objects
 - ___ Standard operating procedures
 - ___ access procedures
 - ___ research and reference standard operating procedures
 - ___ handling procedures
 - ___ monitoring research space
 - ___ duplicating and reformatting
- ___ Research space
 - ___ Conditions
 - ___ dedicated space
 - ___ security
 - ___ adequate space
 - ___ location adjacent to work and storage space
 - ___ adequate equipment and utilities
 - ___ disabled access
- ___ Restrictions and legal issues
 - ___ Restrictions
 - ___ donor
 - ___ sensitive data
 - ___ Legal issues and compliance
 - ___ copyright
 - ___ privacy and publicity
 - ___ Archaeological Resources Protection Act
 - ___ National Historic Preservation Act
 - ___ Endangered Species Act
 - ___ Public Law 105-391, Title II-National Park System Resource Inventory and Management
 - ___ Freedom of Information Act
 - ___ Native American Graves Protection and Repatriation Act

___ Publications

___ Forms

- ___ intellectual property permission request
- ___ assignment of copyright by contractor
- ___ cooperative publishing agreement
- ___ model release form
- ___ Memorandum of Agreement or contract with publisher

___ Standard operating procedures

- ___ publication project checklist
- ___ digital publications project checklist
- ___ Museum Management Program editing checklist

___ Reproductions

___ Forms

- ___ reproduction order notification sheet
- ___ permission to publish
- ___ agreements and contracts for reproductions
- ___ standard operating procedures for 2-D and 3-D reproductions

___ Special uses

___ Forms

- ___ special use permit
- ___ hold harmless or liability clause to be included in a special use permit
- ___ conditions included in special use permit for spaces housing museum collections

___ Procedures

- ___ filming and photography in spaces housing museum collections
- ___ special events in exhibit spaces
- ___ keeping objects in working order
- ___ museum objects used in performance, sound production or demonstration
- ___ museum objects used in educational and interpretive programs

___ Research

___ Staff knowledge of library research techniques

- ___ basic research
- ___ special sources on archives
- ___ special sources on museum objects

___ Staff knowledge of museum research techniques

___ Staff knowledge of archival research techniques

___ Staff knowledge of Web searching techniques

___ Staff knowledge of how to interview potential researchers

X. STAFFING

___ Archives Technician (1421 series)

___ Archivist (1420 series)

___ Curator (1015 series)

- Museum and Archival Aid
- Museum Technician (1016 series)
- Park Ranger with collateral duty
- Supervisor/park division (Interpretation/Resource Management)
- Registrar (1001)
- VIPs and student interns

- Training and experience of incumbent(s)
 - Training needs
 - Basic curatorial training
 - Archives management knowledge including: arrangement, description, handling, rehousing, deterioration and preparation for treatment, reformatting, reference services and research, cataloging in ANCS+ (including descriptive standards), finding aid production, archival guide production, intellectual property rights (copyrights, privacy, and publicity) and restrictions issues
 - ANCS+ training
 - Conservation management including identifying deterioration and treatment needs, project planning, working with a conservator, contract requirements for survey, treatment and analysis, using the Conservation Module in ANCS+

- Adequate positions for workload

XII. PLANNING, PROGRAMMING, AND FUNDING

- Park planning documents include collections
 - General Management Plan (GMP)
 - Park Strategic Plan
 - Annual Performance Plan
 - Resources Management Plan (RMP)

- Funding sources
 - Backlog Cataloging (BACAT)
 - Cooperating associations
 - Cultural Cyclic Maintenance Funds
 - Cultural Resources Preservation Program (CRPP)
 - Museum Collections Preservation and Protection (MCPPE) Program
 - ONPS (base funding)
 - Recreational Fee Demonstration Program
 - other

**D. NPS Collection
Management Plan Team
Reference Document
Checklist**

The checklist in this section provides a list of park related documents (e.g., legislation, park-specific plans, general park information, park museum operational procedures, curatorial budget, curatorial position descriptions and performance standards) that the team members will need to review and evaluate. Some of these documents (for example, Scope of Collection Statement, General Management Plan, Park Strategic Plan, Annual Performance Plan, Resources Management Plan, NPS Checklist for Preservation and Protection of Museum Collections, Collections Management Reports) may be requested before the team's site visit.

**NATIONAL PARK SERVICE
COLLECTION MANAGEMENT PLAN TEAM REFERENCE DOCUMENT CHECKLIST**

Legislation

- Enabling legislation, presidential proclamation, or executive order
- Subsequent legislation
- Congressional background reports
- Other:

General Information

- Brochure(s)
- Handbook
- Other:

General Park Plans

- General Management Plan
- Strategic Plan
- Annual Performance Plan
- Resources Management Plan (Cultural and Natural - including project statements related to collections and facilities housing them)

Plans and Documentation Specific to Museum Collections

- Scope of Collection Statement
- Collection Management Plan
- Annual Inventory of Museum Property
- Exhibit Plan(s) (including list of objects)
- Historic Furnishings Report(s)
- Collection Condition Survey(s)
- Collection Storage Plan
- Collections Management Report (Form 10-94)
- Checklist for Preservation and Protection of Museum Collections

Other Pertinent Resource Management Plans

- Historic Resource Study
- Historic Structure Report(s)
- Inventory and Condition Assessment Program (ICAP)
- Ethnographic plans
- Archeological plans
- Other:

Park Museum Collection Management Procedures

- Procedures for access and use of museum collection
- Opening and closing procedures for museum exhibit and storage spaces
- Housekeeping plans/schedules
- Park's Emergency Operation Plan (including Structural Fire, Physical Security, Disaster/Emergency Plans)

- ___ Integrated Pest Management Plan
- ___ Building/facility cyclical maintenance manuals/schedules

Other Park Procedures and Documents Relevant to Collection Management

- ___ Construction drawings or blue prints for buildings housing museum collection (visitor centers, storage rooms, furnished historic structures, etc.)
- ___ Basic operating plan
- ___ Staffing/organization chart
- ___ Position description(s) for staff assigned curatorial responsibilities
- ___ Performance standards for staff assigned curatorial responsibilities and supervisor
- ___ Current budget
- ___ Cooperative agreements
- ___ Project Management Information System (PMIS) Statements
- ___ Current permits (36 CFR 2.5g), if expected to generate specimens for the museum collection
- ___ Performance Management Data System (PMDS) entries for collections-related Strategic Plan goals (Ia6, Ib2D, others)

E. List of Figures

F.1. Cost Estimates	F:28
F.2. NPS Checklist for Preservation and Protection of Museum Collections.....	F:32

Cost Estimates (2005)

NOTE: \$/SF = costs per square foot

Administrative Offices (For costs, see appropriate categories below.)

Museum Collections Storage

Dollars

Museum Facility

- Renovating an existing facility 68-113/SF
- Constructing a new facility (DSC designed and coordinated project, does not include site preparation)..... 248-363/SF
- Insulated Modular Structures (IMS) - recommended only for use inside an existing structure. (See *COGs* 4/7 and 4/8). Costs range from small structures without HVAC, security, and fire protection systems that are assembled by unit staff to large structures with HVAC, security, and fire protection systems that are assembled by a contractor. 60-145/SF
- IMS within an enclosing wood frame or masonry structure built specifically to accommodate the IMS. The cost includes climate control, security and fire protection systems. 106-220/SF
- Park-built structures, including climate control, security and fire protection systems 100-175/SF
- Contractor-built structures, including climate control, security and fire protection systems. 100-200/SF

NOTE: Construction costs vary with the type, size, and configuration of the structure; the locality (costs in Alaska could double those cited); the difficulties of site preparation; and the complexity of the HVAC, security, and fire protection systems. Costs for systems range from \$4-15/SF for fire detection/suppression systems, \$4-6/SF for intrusion detection systems, and \$22-44/SF for HVAC systems. The cost for architectural and engineering planning such as facility preliminary design (Title I) and design and specifications (Title II) may be absorbed in the overall cost of the building (if contractor or park designed and constructed), cost up to \$20/SF if obtained separately, or be 17% of the overall project cost if DSC designed and constructed.

Equipment and Supplies

- Retrofit gasket kit 40
- Sash lock 12
- Standard museum cabinet w/10 drawers 775-1,410
- Doublewide museum cabinet w/10 drawers 1,315-1,984
- Wardrobe cabinet w/specialized storage interiors (depends on interior) 1,700-3,300
- Herbarium cabinet, counter height (12 compartments)..... 567
- Herbarium cabinet, full height (26 compartments)..... 765
- Entomology cabinet, counter height (15 drawer openings)..... 680
- Entomology cabinet, full height (24 drawer openings)..... 1,185-2356
- Cornell drawers for entomology cabinets..... 41
- Security gun vault with acrylic museum assemblies 2,000
- High density moveable-aisle storage systems 125/SF
- Slotted metal angle for constructing large shelving units (bundles of 10 – 12' angle pieces with 75 nuts and bolts) (2 bundles are needed for unit of 3 shelves measuring 4' x 8'; 3 bundles are needed for unit of 5 shelves measuring 4' x 8') 160/Bundle
- 5/8" – 3/4" plywood sheets for shelving..... 40/Sheet

Figure F.1. Cost Estimates (2005)

	<u>Dollars</u>
• Steel shelving units.....	250/unit
• Map cabinet 5-drawer unit (need 2 units for counter height).....	760
• Map cabinet base units.....	250
• Sanitary platform for standard museum cabinet.....	68
• Sanitary platform for doublewide museum cabinet.....	87
• Sanitary platform for wardrobe cabinet.....	128
• Safety stacking rim for standard cabinet.....	35
• Lumber, plywood and paint to construct wooden platform (labor not included) for	
Standard museum cabinet.....	45
Doublewide and wardrobe cabinet.....	55
• Flammable liquid cabinet (various sizes).....	200-700
• GSA utility cabinet for forms and museum supplies.....	240
• Costs for polyethylene foam, specimen trays and specialized containers as listed in <i>NPS Tools of the Trade</i> vary greatly. Call vendors listed in <i>Tools of the Trade</i> for current prices. Units may order modest quantities of these materials through the Museum Supply and Equipment Program, Museum Management Program.	
 NOTE: The costs for equipment do not include shipping. Shipping costs can be as high as 1/3 of the cost of the equipment when shipped in the contiguous United States, higher when shipped to Alaska, Hawaii, Guam and other locations outside the continental United States.	
 Museum Exhibit	
<u>Equipment and Supplies</u>	
• Replacing an exhibit case	
Table top or pedestal exhibit case.....	2,800-11,000
Walk-in-style exhibit case.....	11,000-33,000
• Retrofitting existing exhibit case	
Retrofit of exhibit case, e.g., surfaces/paints, graphics/furniture replacement.....	2,200-5,500
Retrofit of exhibit case structure, e.g., physical security, lighting component.....	3,000-11,000
Retrofit of object mount, e.g., single mount, garment manikin.....	550-3,300
 NOTE: Exhibit replacement and retrofitting costs vary with the size and complexity of the exhibit case. Factors affecting cost include whether or not there is a need for specialized humidity control, lighting, security and museum mount features; the availability of specialized contractors; and the proximity of contractors to the park.	
 Museum Environment	
<u>Museum Facility</u>	
HVAC System.....	24-46/SF
 <u>Equipment and Supplies</u>	
• Hygrothermograph.....	625
• Datalogger (temperature and RH recording).....	55-565
• Remote probe for datalogger (for use in exhibit cases).....	200
• Datalogger computer software for setting up instruments and analyzing data.....	95-140

Figure F.1. Cost Estimates (2005) (continued)

	<u>Dollars</u>
• Electronic thermohygrometer (depending on brand and style).....	325-1,000
• Sling psychrometer.....	25-125
• Aspirated psychrometer.....	423
• Hygrometer.....	30-100
• Portable dehumidifier (refrigerant type).....	300
• Portable dehumidifier (desiccant type).....	1,000
• Humidifier.....	300
• Portable air purifier with HEPA and activated carbon filters.....	450
• Visible light meter.....	150
• UV (ultraviolet radiation) meter.....	1,500
• Vacuum cleaner (HEPA).....	600-1,100
• UV fluorescent filtering sleeves.....	7
• UV filtering acrylic (Plexiglas [®] , OP-2 [®] , or similar)	
8" x 10" sheet.....	10
20" x 24" sheet.....	45
4' x 8' x 1/4" sheet.....	300
• UV filtering film professionally installed on windows.....	10/SF
Security	
<u>Museum Facility</u>	
Intrusion detection system (approximate minimum \$2,000).....	5-7/SF
<u>Equipment and Supplies</u>	
• Recoring locks (contact locksmith or maintenance staff for costs)	
• Locking key boxes.....	40-60
• Metal or solid core doors.....	275-450
• Deadbolt locks.....	50
Fire Protection	
<u>Museum Facility</u>	
• Fire detection system.....	5-7/SF
• Fire suppression system	
Wet pipe system (includes smoke or heat detection system).....	10-15/SF
Dry pipe system (includes smoke or heat detection system).....	12-16/SF
NOTE: Costs increase if the system requires the installation of a new dedicated National Fire Protection Association (NFPA) approved 4" or 6" water line or if there is a need for a water storage reservoir. Specific estimated costs for installation of water line and storage reservoir include:	
• Pipe installation.....	43/LF
• Backflow preventer.....	12,650
• Gate valve.....	1,330-2,100
• Water meter and box.....	11,400
• Connection to existing line.....	2,900
• 10,000 gallon steel on-grade storage reservoir.....	40,250
(Prices vary with capacity and type of construction.)	

Figure F.1. Cost Estimates (2005) (continued)

Equipment and Supplies

- ABC fire extinguisher (20 pound unit).....70
- ABC fire extinguisher (10 pound unit).....50
- Flammable liquid cabinet (various sizes)..... 200-700
- Four-drawer insulated file cabinet 840
- Media vault 245
- Media safe (various sizes)..... 3,000-16,000

Professional Assistance and Museum Planning

- Assistance with establishing optimum relative humidity and temperature levels3,500-6,000
- Security Survey 9,000-12,000
- Fire Protection Survey 9,000-12,000
- Collection Management Plan12,000-25,000
- Collection Condition Survey..... 10,000-20,000
- Collection Storage Plan 7,000-13,000
- Integrated Pest Management Plan 10,000-15,000
- Housekeeping Plan 10,000-15,000

Figure F.1. Cost Estimates (2002) (continued)

**NATIONAL PARK SERVICE CHECKLIST
FOR PRESERVATION AND PROTECTION
OF MUSEUM COLLECTIONS**

**Department of the Interior
National Park Service
National Center for Cultural Resources
Park Museum Management Program**

(Park/Center Acronym)

1

**NATIONAL PARK SERVICE
CHECKLIST FOR PRESERVATION AND PROTECTION
OF MUSEUM COLLECTIONS**

CHECKLIST COVER SHEET

Please complete and attach this cover sheet to your completed checklist.

Unit Name: _____

Unit Address: _____
(Street Address)

(P.O. Box Number)

(City, State, Zip Code)

Telephone Number: _____ Fax Number: _____

Completed by: _____ Date: _____
(Print/Type Name)

(Print/Type Title)

(Print/Type Name) Date: _____

(Print/Type Title)

Reviewed/Approved by: _____
(Print/Type Park Superintendent/Center Manager Name)

(Park Superintendent/Center Manager Signature) Date: _____

Figure F.2. NPS Checklist for Preservation and Protection of Museum Collections (continued)

CHECKLIST

TABLE 1: UNIT FACILITIES HOUSING MUSEUM COLLECTIONS

Facility Code	Name and Type of Facility	Type of Museum Space
A	Museum Collection Building (<i>Example Entry</i>)	S
B	Visitor Center (<i>Example Entry</i>)	E
C	Visitor Center (Park Headquarters Offices) (<i>Example Entry</i>)	A
1		
2		
3		
4		
5		
6		
7		
8		
9		
10		
11		
12		
13		
14		
15		
16		
17		
18		
19		
20		
21		
22		

Figure F.2. NPS Checklist for Preservation and Protection of Museum Collections (continued)

CHECKLIST

(Park/Center Acronym)

3

A. ADMINISTRATIVE OFFICES

Are framed artwork or other museum objects (e.g., furniture) on display in one or more administrative offices of the unit?

YES ___ NO ___

If the response is YES, complete this section of the checklist.

Operations (Procedural):

1. Issuing keys to office spaces housing museum objects is strictly controlled by the use of a signed hand receipt. YES ___ NO ___
2. Opening and closing procedures are written, approved, and practiced. YES ___ NO ___
3. If time allows in a pending disaster (e.g., storm, flood, fire), there are instructions that provide guidance for the prioritized safe and secure evacuation of artwork. YES ___ NO ___
4. Smoking is prohibited in offices housing museum objects. YES ___ NO ___
5. Levels of relative humidity and temperature are monitored and recorded. YES ___ NO ___
6. The placement of artwork is away from heating and air-conditioning vents. YES ___ NO ___
7. The visible spectrum of light is monitored for illuminance level and duration, is controlled, and meets the standards outlined in the NPS *Museum Handbook*, Part I (Sep 90). YES ___ NO ___
8. The placement of artwork is such that outside light does not directly fall on object(s). YES ___ NO ___
9. Handling and dusting of museum property is performed only by staff who have received appropriate training. YES ___ NO ___
10. Three-dimensional materials are displayed in areas that minimize accidental damage. (If there are no three-dimensional materials on display, respond NA indicating not applicable.) YES ___ NO ___
NA ___

Equipment and Supplies:

11. Ultraviolet (UV) radiation is controlled by a filtering material that has UV absorbing properties. YES ___ NO ___

Deficiency:

Cost: \$ _____

Figure F.2. NPS Checklist for Preservation and Protection of Museum Collections (continued)

	_____ (Park/Center Acronym) 4
CHECKLIST	
12. Artwork is properly framed and is securely hung on the wall.	YES___ NO___
Deficiency:	Cost: \$ _____
<u>Professional Assistance and Museum Planning:</u>	
13. Through a Collection Condition Survey (CCS), conservators have provided the unit a condition assessment of artwork and other museum property in administrative offices and guidance on setting priorities for care and conservation treatment.	YES___ NO___
Deficiency:	Cost: \$ _____
B. MUSEUM COLLECTIONS STORAGE	
Are museum collections stored in a facility located within the unit? If the response is YES, complete this section of the checklist.	YES___ NO___
<u>Museum Facility:</u>	
1. The museum storage area is used solely for storage of museum objects.	YES___ NO___
Deficiency:	Cost: \$ _____
2. The curatorial office and research/reference and work areas are separated from the museum collections storage space.	YES___ NO___
Deficiency:	Cost: \$ _____

Figure F.2. NPS Checklist for Preservation and Protection of Museum Collections (continued)

CHECKLIST		(Park/Center Acronym) 5
3.	Flammable liquids and materials, audiovisual equipment and other interpretive materials, and curatorial forms and supplies are stored outside the museum storage space in an appropriate cabinet.	YES___ NO___
	Deficiency:	Cost: \$ _____
4.	The space is outside the 100-year floodplain.	YES___ NO___
	Deficiency:	Cost: \$ _____
5.	The space is in an area that will not flood if pipes break, or drains back up.	YES___ NO___
	Deficiency:	Cost: \$ _____
6.	The space is appropriately insulated to help maintain environmental conditions.	YES___ NO___
	Deficiency:	Cost: \$ _____
7.	If space has windows, they are blocked (e.g., covered with plywood sheets) and insulated. (If space has no windows, respond NA indicating not applicable.)	YES___ NO___ NA___
	Deficiency:	Cost: \$ _____

Figure F.2. NPS Checklist for Preservation and Protection of Museum Collections (continued)

CHECKLIST		(Park/Center Acronym) 6
8.	Space has as few doors as possible to enhance security and environmental control, but has enough to meet requirements for employee safety. Deficiency:	YES___ NO___ Cost: \$ _____
9.	Space is as free of water, steam, drain, and fuel pipes as is practical. Deficiency:	YES___ NO___ Cost: \$ _____
10.	Space is free of water, gas, or electric meters, electrical panels, and utility valves that require monitoring and servicing by non-curatorial personnel. Deficiency:	YES___ NO___ Cost: \$ _____
11.	Space is sufficient for the movement of staff, equipment, and objects in and out without hindrances (e.g., low ceilings; inadequately sized doors; or narrow, winding, or steep stairways). Deficiency:	YES___ NO___ Cost: \$ _____
12.	Space is large enough to accommodate the current museum collection and any anticipated growth. Deficiency:	YES___ NO___ Cost: \$ _____

Figure F.2. NPS Checklist for Preservation and Protection of Museum Collections (continued)

CHECKLIST		(Park/Center Acronym)
		7
13. Space is organized in a way that allows for easy access to museum objects and use of proper storage equipment.	YES___ NO___	
Deficiency:	Cost: \$ _____	
<u>Equipment and Supplies:</u>		
14. Sufficient equipment (e.g., quantities, sizes, and appropriateness of cabinets, shelving units, and specialized racks) is used to store and contain museum objects without crowding.	YES___ NO___	
Deficiency:	Cost: \$ _____	
15. Museum storage cabinets are in good condition (e.g., are free of rust, have gaskets intact to provide good sealing action, have smoothly operating doors) and have working, keyed or combination lock mechanisms.	YES___ NO___	
Deficiency:	Cost: \$ _____	
16. Museum cabinet drawers are not loaded beyond the manufacturer's recommended weight capacity.	YES___ NO___	
Deficiency:	Cost: \$ _____	

Figure F.2. NPS Checklist for Preservation and Protection of Museum Collections (continued)

CHECKLIST		(Park/Center Acronym) 8
17. Museum cabinets are stacked no more than two high.	YES___ NO___	
Deficiency:	Cost: \$ _____	
18. Open shelving is free of burrs, splinters, exposed nails, screws, and bolts that can damage museum objects.	YES___ NO___	
Deficiency:	Cost: \$ _____	
19. Museum objects that are stacked are protected by appropriate containers or cushioning materials.	YES___ NO___	
Deficiency:	Cost: \$ _____	
20. Museum cabinets are raised off the floor at least 4" (preferably 6") as a precaution against potential flooding and to facilitate cleaning of floors and inspection for pest problems. Bottom shelves of shelving units are raised off the floor 4" to 6".	YES___ NO___	
Deficiency:	Cost: \$ _____	
21. Open shelving is stabilized to prevent it from tipping over.	YES___ NO___	
Deficiency:	Cost: \$ _____	

Figure F.2. NPS Checklist for Preservation and Protection of Museum Collections (continued)

CHECKLIST	(Park/Center Acronym) 9
22. The unit is in an earthquake zone.	YES___ NO___
23. Restraining bars or cords are attached to edges of shelves to prevent objects from falling off shelves during an earthquake. (If your response to item 22 is NO, respond NA indicating not applicable.)	YES___ NO___ NA___
Deficiency:	Cost: \$ _____
24. Closed cell polyethylene foam is used in museum cabinet drawers and on shelving to cushion objects. (<u>Exception</u> : If natural history specimens are to be used for analysis of organic chemicals, do not use any kind of plastic in storage containers.)	YES___ NO___
Deficiency:	Cost: \$ _____
25. Objects in museum cabinets are placed in specimen trays, padded or otherwise prevented from shifting when drawers are opened and closed.	YES___ NO___
Deficiency:	Cost: \$ _____
26. Museum objects and archival materials are housed in storage containers or on mounts (e.g., boxes, folders, envelopes, herbarium paper) that are made of museum/archival quality materials.	YES___ NO___
Deficiency:	Cost: \$ _____

Figure F.2. NPS Checklist for Preservation and Protection of Museum Collections (continued)

CHECKLIST		(Park/Center Acronym) 10
27. Natural history specimens stored in fluids are housed in a space that provides appropriate ventilation. (If there are no specimens stored in fluids, respond NA indicating not applicable.)	YES___ NO___ NA___	
Deficiency:		Cost: \$ _____
28. Natural history specimens stored in fluids are housed separately from dry specimen collections. (If there are no specimens stored in fluids, respond NA indicating not applicable.)	YES___ NO___ NA___	
Deficiency:		Cost: \$ _____
29. Nitrate film is housed in buffered sleeves or envelopes, placed in Ziplock™ polyethylene bags, and stored in appropriate frost-free freezers in separate space from all other collections. (If there is no nitrate film, respond NA indicating not applicable.)	YES___ NO___ NA___	
Deficiency:		Cost: \$ _____
30. Spaces and/or cabinets housing specimens stored in fluids, specimens treated with pesticides, rocks/minerals/fossils that are radioactive, or nitrate film are identified by appropriate health/safety sign. (If there are none of these materials, respond NA indicating not applicable.)	YES___ NO___ NA___	
Deficiency:		Cost: \$ _____

Figure F.2. NPS Checklist for Preservation and Protection of Museum Collections (continued)

CHECKLIST	(Park/Center Acronym) 11
 C. EXHIBITS	
Are museum collections exhibited in a facility located within the unit? If the response is YES, complete this section of the checklist.	YES ___ NO ___
<u>Operations (Procedural):</u>	
1. Exhibit plans and historic furnishings reports are reviewed by curatorial staff to ensure that preservation, protection, and maintenance needs of museum objects are adequately addressed.	YES ___ NO ___
Deficiency:	
 <u>Museum Facility:</u>	
2. The space is outside the 100-year floodplain.	YES ___ NO ___
Deficiency:	Cost: \$ _____
3. The space is in an area that will not flood if pipes break, or drains back up.	YES ___ NO ___
Deficiency:	Cost: \$ _____
 <u>Equipment and Supplies:</u>	
4. Exhibit cases are designed and fabricated in a manner that ensures the security and preservation of museum property (e.g., uses tamper-resistant screws; minimizes heat build up; controls light, relative humidity, dust levels; and prevents access by insects). (If there are no exhibit cases, respond NA indicating not applicable.)	YES ___ NO ___ NA ___
Deficiency:	Cost: \$ _____

Figure F.2. NPS Checklist for Preservation and Protection of Museum Collections (continued)

	_____ (Park/Center Acronym) 12
CHECKLIST	
5. Exhibit cases are designed and fabricated in a manner that facilitates maintenance (i.e., ease of access for inspection, inventory, cleaning, rotation of sensitive materials). (If there are no exhibit cases, respond NA Indicating not applicable.) Deficiency:	YES___ NO___ NA___ Cost: \$ _____
6. Where needed, mounts constructed of museum quality material are used to support objects and specimens. (If there are no mounts, respond NA indicating not applicable.) Deficiency:	YES___ NO___ NA___ Cost: \$ _____
7. Freestanding museum objects on exhibit are protected by physical barriers, alarm detection systems, or staff on duty. (If there are no freestanding objects, respond NA indicating not applicable.) Deficiency:	YES___ NO___ NA___ Cost: \$ _____
D. MUSEUM ENVIRONMENT	
<u>Operations (Procedural):</u>	
1. Levels of relative humidity and temperature in storage and exhibit spaces are monitored on a daily basis to provide an accurate and complete picture of all changes in both of these environmental factors during each year. (If response is NO and unit does not have monitoring equipment, include equipment purchase cost in item 11.) Deficiency:	YES___ NO___

Figure F.2. NPS Checklist for Preservation and Protection of Museum Collections (continued)

CHECKLIST

(Park/Center Acronym)

13

2. A record of daily observations, noting occurrences such as unusual exterior climatic conditions, leaky roof, re-calibration of equipment, or an unusual visitation pattern, is maintained to help explain any variations in relative humidity and temperature readings. YES___ NO___

Deficiency:

3. Records of relative humidity and temperature readings and of daily observations are permanently retained in the unit's curatorial files. YES___ NO___

Deficiency:

4. Records of relative humidity and temperature readings and of daily observations are reviewed and analyzed monthly to determine relative humidity and temperature highs, lows, and means; and the frequency and extent of fluctuations. YES___ NO___

Deficiency:

5. The visible spectrum of light is monitored and recorded for illuminance level and duration. (If response is NO and unit does not have a light meter, include purchase cost under item 11.) YES___ NO___

Deficiency:

6. Levels of natural light (daylight) have been recorded quarterly for one year to establish seasonal variations. YES___ NO___

Deficiency:

Figure F.2. NPS Checklist for Preservation and Protection of Museum Collections (continued)

CHECKLIST		(Park/Center Acronym)
		14
7.	The unit has a record of annual seasonal variations and periodically spot checks to ensure that levels do not exceed the upper limits for sensitive objects. Deficiency:	YES___ NO___
8.	UV filtering material is periodically monitored to ensure its continued effectiveness in meeting the standard in the NPS <i>Museum Handbook</i> , Part I (Sep 90), Chapter 4. (If there is no UV filtering material, respond NA indicating not applicable.) Deficiency:	YES___ NO___ NA___
9.	Monitoring (inspections) for evidence of insect, mold, and rodent infestations is conducted on an ongoing basis with especially close inspection of museum objects on a monthly basis. Deficiency:	YES___ NO___
10.	The monitoring and control of pests is coordinated with the unit's Integrated Pest Management Program. Deficiency:	YES___ NO___

Figure F.2. NPS Checklist for Preservation and Protection of Museum Collections (continued)

CHECKLIST

(Park/Center Acronym)

15

Equipment and Supplies:

11. The unit has appropriate equipment (e.g., hygrothermograph, datalogger, visible light meter, UV monitor) to implement and maintain an ongoing environmental monitoring program. YES___ NO___

Deficiency: Cost: \$ _____

12. The park has installed equipment/system in each space housing museum collections to control relative humidity and temperature. YES___ NO___

Deficiency: Cost: \$ _____

13. The visible spectrum of light is controlled to meet the standard in NPS *Museum Handbook*, Part I (Sep 90), Chapter 4. YES___ NO___

Deficiency: Cost: \$ _____

14. Ultraviolet (UV) radiation is controlled by a filtering material that has UV absorbing properties. YES___ NO___

Deficiency: Cost: \$ _____

15. Dust covers are used on open shelving when objects are not otherwise protected from dust (e.g., in boxes). (If there is no open shelving, respond NA indicating not applicable.) YES___ NO___
NA___

Deficiency: Cost: \$ _____

Figure F.2. NPS Checklist for Preservation and Protection of Museum Collections (continued)

CHECKLIST		(Park/Center Acronym) 16
16. Particulates (dust) in museum storage and exhibit spaces are controlled.	YES___ NO___	
Deficiency:	Cost: \$ _____	
E. SECURITY		
<u>Operations (Procedural):</u>		
1. Keys to museum storage spaces, exhibit cases, and work and research/reference spaces are issued to only those employees having direct responsibility for the collections.	YES___ NO___	
Deficiency:	Cost: \$ _____	
2. Issuing of keys to museum storage spaces and exhibit cases is strictly controlled by the use of a signed hand receipt (e.g., DI-105 or equivalent form).	YES___ NO___	
Deficiency:		
3. Written, approved procedures for controlling access to the museum collections by non-curatorial staff, outside researchers, and visitors are implemented.	YES___ NO___	
Deficiency:		

Figure F.2. NPS Checklist for Preservation and Protection of Museum Collections (continued)

CHECKLIST		(Park/Center Acronym) 17
<p>4. All researchers, visitors, and non-curatorial staff who enter the storage area are escorted at all times by unit curatorial staff. (For exhibit spaces, respond NA indicating not applicable.)</p> <p>Deficiency:</p>	<p>YES___ NO___ NA___</p>	
<p>5. A visitor/researcher sign-in log is used to record name and address of visitor, date of visit, time entered and time departed, and reason for visit. (For exhibit spaces, respond NA indicating not applicable.)</p> <p>Deficiency:</p>	<p>YES___ NO___ NA___</p>	
<p>6. Opening and closing procedures for museum spaces are written, approved and practiced.</p> <p>Deficiency:</p>	<p>YES___ NO___</p>	
<p>7. Museum objects in exhibit spaces are given additional protection at times of high risk, such as during times of crowding or of special activities. (If there are no exhibits, respond NA indicating not applicable. For storage spaces, respond NA indicating not applicable.)</p> <p>Deficiency:</p>	<p>YES___ NO___ NA___</p>	
<p>8. The special needs of museum collections and records are incorporated into the unit's Emergency Operation Plan (EOP).</p> <p>Deficiency:</p>	<p>YES___ NO___</p>	<p>Cost: \$ _____</p>

Figure F.2. NPS Checklist for Preservation and Protection of Museum Collections (continued)

CHECKLIST

(Park/Center Acronym)

18

9. Installed intrusion detection systems are inspected and maintained on a regular schedule to ensure that they are fully operational. (If there are no intrusion detection systems, respond NA indicating not applicable.) YES___ NO___
NA___

Deficiency:

10. The unit has determined the extent to which museum collections and associated museum records are at risk from the threats listed in the NPS *Museum Handbook*, Part I (Sep 90), Chapters 9 and 10. YES___ NO___

Deficiency:

Museum Facility:

11. Entrances to museum spaces are equipped with metal or solid-core wood doors that have deadbolt locks. YES___ NO___

Deficiency:

Cost: \$ _____

12. Intrusion detection systems appropriate to the risks involved and to the nature of the museum collection are installed and operable in museum storage and exhibit spaces. YES___ NO___

Deficiency:

Cost: \$ _____

Figure F.2. NPS Checklist for Preservation and Protection of Museum Collections (continued)

CHECKLIST

(Park/Center Acronym)
19

Equipment and Supplies:

13. Small, highly sensitive and valuable museum objects, archival documents, and natural history type specimens housed in museum storage spaces are kept in locked cabinets with keyed or combination locks. (If there are none of these objects, respond NA indicating not applicable.)
- YES ___ NO ___
NA ___

Deficiency: _____ Cost: \$ _____

14. Irreplaceable or particularly sensitive or valuable objects used in exhibits are protected in cases or by other means that provide protection from theft or vandalism, without making curatorial access impractical. (If there are none of these objects, respond NA indicating not applicable.)
- YES ___ NO ___
NA ___

Deficiency: _____ Cost: \$ _____

F. FIRE PROTECTION

Operations (Procedural):

1. Fire detection and suppression systems are inspected and maintained on a regular schedule to ensure that they are fully operational. (If unit has no fire detection or suppression systems, respond NA indicating not applicable.)
- YES ___ NO ___
NA ___

Deficiency: _____

2. Fire extinguishers are inspected annually to ensure that they are operational.
- YES ___ NO ___

Deficiency: _____

Figure F.2. NPS Checklist for Preservation and Protection of Museum Collections (continued)

CHECKLIST		(Park/Center Acronym) 20
3.	Staff are trained in the use of fire extinguishers. Deficiency:	YES___ NO___
4.	Museum objects on top of shelving or museum cabinets do not obstruct the discharge heads for fire suppression systems and are not closer than 18" to the ceiling. (If there is no fire suppression system, respond NA indicating not applicable.) Deficiency:	YES___ NO___ NA___
5.	The special needs of museum objects and museum records are incorporated in the unit's Structural Fire Plan. Deficiency:	YES___ NO___
6.	Orientation on the location, nature, significance, and specific needs of museum property has been provided to NPS and non-NPS fire fighting entities who are responsible for responding to the suppression of a fire. Deficiency:	YES___ NO___
<u>Museum Facility:</u>		
7.	Spaces housing museum collections and their structural components (e.g., walls, floors, ceilings, doors and windows) are made fire-resistant to the extent possible, given the nature of the structure. Deficiency:	YES___ NO___ Cost: \$ _____

Figure F.2. NPS Checklist for Preservation and Protection of Museum Collections (continued)

CHECKLIST		(Park/Center Acronym) 21
8. Fire detection and suppression systems appropriate to the risks involved, to the nature of the museum collection, and to the structure housing the collections <u>are installed and operable</u> .	YES___ NO___	
Deficiency:		Cost: \$ _____
 <u>Equipment and Supplies:</u>		
9. An appropriate number and type of fire extinguishers are installed according to the anticipated types of fires, the nature of the collection, and the size of the protected area.	YES___ NO___	
Deficiency:		Cost: \$ _____
10. Flammable liquids and materials are housed outside museum storage spaces and, regardless of where stored, such materials are housed in approved flammables storage cabinets with proper ventilation. (For exhibit spaces, respond NA indicating not applicable.)	YES___ NO___ NA___	
Deficiency:		Cost: \$ _____
11. All <u>paper museum records</u> are kept in a locking, insulated safe, file, or vault with equivalent or better protection that will maintain an interior temperature of less than 350°F during a one-hour exposure to exterior temperatures of at least 1700°F.	YES___ NO___	
Deficiency:		Cost: \$ _____

Figure F.2. NPS Checklist for Preservation and Protection of Museum Collections (continued)

CHECKLIST

12. If the container described in item 11 is housed on a level of a building above grade, the container also is rated to withstand a drop of 30 feet. (If there is no container or if the container is housed below grade, respond NA indicating not applicable.) YES___ NO___
NA___

Deficiency: Cost: \$ _____

13. Magnetic media (floppy disks and tapes) that back up NPS Automated National Catalog System (ANCS) data files and other collection data files are stored in a container (e.g., media safes, media files, mixed media files, and media boxes) that will maintain an interior temperature of not more than 125°F during a one hour exposure to an exterior temperature of 1700°F. (NOTE: Media boxes are acceptable only when inserted in an appropriately rated insulated records file as described in item 11.) YES___ NO___

Deficiency: Cost: \$ _____

G. HOUSEKEEPING

Operations (Procedural):

1. Housekeeping in museum storage and exhibit spaces is performed according to a plan's established schedule. YES___ NO___

Deficiency:

2. Written rules and procedures are available to provide staff with guidance on the handling and moving of museum objects. YES___ NO___

Deficiency:

Figure F.2. NPS Checklist for Preservation and Protection of Museum Collections (continued)

CHECKLIST

(Park/Center Acronym)
23

3. Smoking, drinking, and eating and displaying living plants, fresh flowers, and foodstuffs in museum storage and exhibit spaces and in research, working, and research/reference spaces are prohibited in writing. YES___ NO___

Deficiency:

4. Relative humidity and temperature monitoring equipment is calibrated quarterly. (If there is no monitoring equipment, respond NA indicating not applicable.) YES___ NO___
NA___

Deficiency:

5. If a hygrothermograph is used to monitor relative humidity and temperature, it is regularly maintained (e.g., linkage is cleaned, ink is replenished). (If a hygrothermograph is not used, respond NA indicating not applicable.) YES___ NO___
NA___

Deficiency:

6. The housekeeping plan for museum spaces is reviewed annually and is revised as necessary. (If there is no housekeeping plan, respond NA indicating not applicable.) YES___ NO___
NA___

Deficiency:

Figure F.2. NPS Checklist for Preservation and Protection of Museum Collections (continued)

CHECKLIST

(Park/Center Acronym)

24

H. PROFESSIONAL ASSISTANCE AND MUSEUM PLANNING

1. Working with museum environment specialists, the unit has established optimum relative humidity and temperature levels and acceptable highs and lows based on data recorded from ongoing monitoring program. YES___ NO___

Deficiency: _____ Cost: \$ _____

2. The unit has conducted a security survey. (If the response is NO, and there is a need for this survey, complete the deficiency and cost blocks below. If there is no need for a security survey, respond NA indicating not applicable.) YES___ NO___
NA___

Deficiency: _____ Cost: \$ _____

3. The unit has conducted a fire protection survey. (If the response is NO, and there is a need for this survey, complete the deficiency and cost blocks. If there is no need for a fire protection survey, respond NA indicating not applicable.) YES___ NO___
NA___

Deficiency: _____ Cost: \$ _____

4. The needs of the museum collection are adequately addressed in project statements that are included in the unit's Resources Management Plan (RMP). YES___ NO___

Deficiency: _____

Figure F.2. NPS Checklist for Preservation and Protection of Museum Collections (continued)

CHECKLIST		(Park/Center Acronym) 25
5. The unit has an approved Collection Management Plan (CMP). Deficiency:	YES___ NO___ Cost: \$ _____	
6. Through a Collection Condition Survey (CCS) or multiple surveys, conservators have provided the unit with an assessment of the condition of material specific objects on exhibit and in storage and have provided guidance on setting priorities for conservation treatment. Deficiency:	YES___ NO___ Cost: \$ _____	
7. The unit has an approved Collection Storage Plan (CSP). (If the response is NO, and there is a special need for this plan, independent of a CMP, complete the deficiency and cost blocks. If there is no need for a Collection Storage Plan, respond NA indicating not applicable.) Deficiency:	YES___ NO___ NA___ Cost: \$ _____	
8. An Integrated Pest Management Plan for all spaces housing museum collections has been written. Deficiency:	YES___ NO___ Cost: \$ _____	
9. A housekeeping plan has been written for museum storage, exhibit, work, and research spaces. Deficiency:	YES___ NO___ Cost: \$ _____	

Figure F.2. NPS Checklist for Preservation and Protection of Museum Collections (continued)

CHECKLIST**TABLE 2: ESTIMATE OF TOTAL FUNDING NEEDED TO CORRECT DEFICIENCIES**

Checklist Categories and Sub-Categories	Costs*
ADMINISTRATIVE OFFICES	\$
MUSEUM COLLECTIONS STORAGE	
Museum Facility	\$
Equipment and Supplies	\$
EXHIBITS	
Operations (Procedural)	Base Funding**
Equipment and Supplies	\$
MUSEUM ENVIRONMENT	
Operations (Procedural)	Base Funding**
Equipment and Supplies	\$
SECURITY	
Operations (Procedural)	\$
Museum Facility	\$
Equipment and Supplies	\$
FIRE PROTECTION	
Operations (Procedural)	Base Funding**
Museum Facility	\$
Equipment and Supplies	\$
HOUSEKEEPING	
Operations (Procedural)	Base Funding**
PROFESSIONAL ASSISTANCE AND MUSEUM PLANNING	\$
UNIT'S ESTIMATED TOTAL COST	\$

* Enter total cost for all items in this checklist category.

** These deficiencies are to be corrected using the unit's base funding.

Figure F.2. NPS Checklist for Preservation and Protection of Museum Collections (continued)

APPENDIX G: PROTECTION OF NATIONAL PARK SERVICE MUSEUM COLLECTIONS

A. Overview

This appendix contains information that supports the guidance we provide in *NPS Museum Handbook*, Part I, Chapter 9, Museum Collections Security and Fire Protection and Chapter 10, Emergency Planning. In this appendix you will find:

- NPS standards for security and fire protection
 - Definitions of security and fire protection terms
 - Sample statements of work for security and fire protection surveys
 - Sample standard operating procedures and agreements
 - Mandates and requirements for emergency management
-

B. NPS Standards for Security and Fire Protection

1. *What general standards do I need to meet?*
 - Identify all threats that may affect the museum collection and take steps to counter those threats.
 - Ensure that the park's museum protection program applies to everyone on the staff.
 - Implement a thorough and vigorously enforced fire prevention program in buildings housing museum collections and museum records.
 - Ensure that systems for detecting and controlling access meet Underwriters Laboratories (UL) standards and systems for detecting and suppressing fires meet UL and National Fire Protection Association (NFPA) standards.
 - Establish a process for evaluating plans for building and exhibit construction and rehabilitation to ensure that security and fire protection objectives will be met.

The NPS Checklist for Preservation and Protection of Museum Collections (1996) includes mandatory standards for museum security and fire protection. See *MH-I*, Appendix F: NPS Museum Collections Management Checklists, Section A for guidance.

2. *What security standards do I need to meet?*
 - Issue keys to storage rooms and exhibit cases only to those employees who have a frequently (at least daily) recurring need for direct, unaccompanied access to collections.
 - Control the issuing of keys strictly by using signed hand receipts (Form DI-105, "Receipt for Property" or its equivalent).

- Write and implement procedures for access to museum collections.
- Ensure that researchers or qualified visitors entering a space housing museum objects are accompanied at all times by someone on the park museum staff.
- Maintain a visitor log to record non-museum staff entries into museum storage and work areas.
- Write and implement opening and closing procedures for museum exhibit, storage, research and work spaces.
- Equip museum storage rooms with secure metal or solid-core wooden doors in substantial frames. Equip those doors with deadbolt locks and other appropriate security hardware, such as non-removable pin hinges.
- Install and maintain intrusion detection systems appropriate to the nature of the facility, the nature and value of the collection, and to the known threats.
- Ensure that intrusion detection systems are inspected and maintained on a regular schedule.
- House highly sensitive and valuable objects (such as firearms) in storage cabinets of an appropriate design with keyed or combination locks.
- Protect irreplaceable or particularly sensitive or valuable objects on exhibit by using appropriate mounts, cases, or security electronics (or some combination of the three) or by other means that will protect them from theft or vandalism without making curatorial access or visitor viewing impractical or difficult.
- Give museum objects, especially those on exhibit, additional protection at times of high risk, such as during special events or when exhibit galleries are particularly crowded, or when uniquely threatened, such as by terrorist threats or attack or during times of civil unrest.

3. *What fire protection standards do I need to meet?*

- Incorporate the needs of museum objects and museum records in the Structural Fire Plan.
- Keep all museum property records (paper and electronic) in appropriate locking fire-resistant filing cabinet, safe, or walk-in vault.
- Protect spaces housing museum collections by automatic fire detection and suppression systems appropriate to the risks involved, the nature of the collection, the nature of the fires that could occur in those spaces (including attention to fuel types and loading), the nature of the structure, and the capabilities and timeliness of responding forces.
- Protect spaces housing collections by appropriately rated, sized, and located portable fire extinguishers.

- Instruct designated park staff in proper techniques to prevent and suppress fires and in emergency evacuation and protection of people, structures, and collections.
 - Ensure that storage shelves and cabinets and exhibit cases do not obstruct discharge of a suppression agent. Minimize potential damage to objects from agent discharge by ensuring that objects are in cabinets or under protective covers.
 - Keep flammable solvents and supplies in museum work spaces only when kept in UL approved safety containers stored inside UL approved flammable storage cabinets. Never house flammable solvents and supplies in collection storage spaces.
 - Prohibit smoking and open flames in collection storage, work, and exhibit areas.
 - Store cellulose nitrate photographic negatives and motion picture film and other flammable or hazardous objects separately from the rest of the museum collection.
 - Construct storage areas and, where possible, exhibit areas of fire-resistant materials.
-

C. Museum Security and Fire Protection Surveys

1. *What are the subjects that I need to address in a security survey?*

The outline below lists subjects that may be addressed during a protection survey.

- The Park or Facility
 - Name or other identifier
 - Function or purpose
 - Location (including proximity to other facilities and communities)
 - Physical nature of the facility and its surroundings
 - Climate
 - Staffing (including nature and size of staff, hours, seasonal variations)
 - Visitor access (including visitor use characteristics, numbers of visitors, hours, seasonal variations)
 - The law enforcement situation (including type of jurisdiction, reaction/response times)
 - Site loss history (including nature/impact of past criminal activity, nature/impact of other loss events, subsequent mitigating/preventive actions, current loss control policies, programs, procedures)

- Perimeter Security (External)
 - Perimeter barriers and access points: nature and effectiveness (including fences, natural barriers, clear zones, underground passages)
 - Cover (such as vegetation) for possible illegal activity
 - Lighting (including nature, location and areas of coverage, maintenance and testing, power supply, circuit, and switching reliability, tamper resistance, operation)
 - Access points (including controls such as gates, locks, and surveillance)
 - Patrols (including nature, frequency, and seasonal variations)
 - Intrusion detection system (including type of system, power supply, tamper resistance, signal transmission method(s) and supervision)
 - Inspection, testing, and maintenance, operating procedures and instructions, and monitoring of alarms

- The Structure Housing Museum Collections
 - Perimeter security (such as doors, windows, loading docks, walls, roofs, floors, basements, attics, and underground tunnels)
 - Interior security (such as connecting doors and pass-throughs, walls and interior windows, ceilings and spaces above them, floors and crawl spaces, duct work, storerooms, closets, utility rooms, vaults, storage cabinets, elevators and stairwells, and hiding places)
 - Locks and related hardware (including types, mounting, and cylinders and keys)
 - Interior lighting (including security, emergency types, mounting, and cylinders and keys, lighting reliability)
 - Intrusion detection system (including detectors, controls, tamper resistance of wiring and components, alarm transmission methods and supervision, inspection, testing, and maintenance, operating procedures and instructions, monitoring of alarms)
 - Fire detection systems (including detectors, controls, power supply, tamper resistance of wiring and components, alarm transmission methods and supervision, inspection, testing, and maintenance, operating procedures and instructions, monitoring alarms)
 - Fire suppression systems (including appropriateness relative to threats, reliability, supervision, inspection, testing, and maintenance, response to activation)
 - Fire prevention programs (including policies and procedures, housekeeping, staff training, evacuation)

- Safes, vaults, and media containers (including type, location, capacity, and use)
- Procedures
 - Key and combination control (including policies and procedures, documentation/records, and security of keys and cores)
 - Building opening and closing (including policies and procedures, checklists, and monitoring by management)
 - Housekeeping practices
 - Employee screening, investigation, and identification
 - Package and material control
 - Visitor control (including control of visitors to staff-only areas, passes, records of visits, and ID's for contractors, tradesmen, utility workers)
 - Visitor surveillance and inspection
 - Protection of administrative records
 - Security of cash and valuables
 - Control of access to restricted areas or facilities (including museum and non-museum staff)
 - Property inventory and control
 - Security communications (including methods, reliability, back-up power, employee operation, and efficiency and speed)
 - Incident reporting (including timeliness, accuracy, and records creation and maintenance)
- Individual Object Protection
 - Storage spaces (including physical construction, access control, housekeeping practices, storage cabinets and shelves, inventory and material movement, and intrusion detection systems)
 - Exhibit spaces (including case construction and object mounting, lighting of space and cases, surveillance by the staff, intrusion and tamper detection systems, inventory, and object removal/movement procedures)
 - Furnished rooms (including access control, intrusion detection systems, housekeeping practices, and inventory)

2. *Where can I obtain a sample scope of work for a security and fire protection survey?*

Figures G.1 and G.2 provide suggested language for a scope of work (SOW) statement for a security survey and a fire protection survey. When contracting for a combined security and fire protection survey, the two documents can be merged and redundant language eliminated. In the sample SOWs, the square brackets [] denote alternative words or phrases, one of which must be chosen and the other deleted, depending upon the situation. Square brackets also mark off optional words and phrases that may be applicable. The text for these sample statements of work is available on diskette or via cc:Mail from your SSO Curator.

D. Park Museum Protection Standard Operating Procedures and Agreements

1. *How do I organize museum standard operating procedures?*

In preparing park-level policy statements and procedures, it is important to distinguish between policies and procedures. Policies express what is allowed and not allowed. Procedures express how to carry out the policies (how, when, by whom, and under what circumstances you put the policies into effect.)

Museum facility standard operating procedures (SOPs) share certain common elements with all standard operating procedures. They all include the following information:

- **Why** the required actions should be performed. When the purposes for having the SOP are made clear, and when the responsible staff fully understand why they must do certain things, the procedures become more valuable.
- **Who** is to perform the required actions. Depending on the circumstances, the SOP may indicate responsibility by name or by position title. The SOP will say that the procedures are to be followed by staff who have the duty by virtue of some roster or work schedule (which you must identify in the SOP). Regardless of how it is done, it is essential that the SOP assign specific responsibility.
- **When** the required actions are to be performed. Usually, specific times are given for either initiating or completing the procedures. The times may vary seasonally or according to the day of the week. It may not be necessary to set a specific time for initiating each action. Simply setting a time to begin the procedures or a time by which they are to be completed will suffice.
- **Where** the required actions are to be performed. For example, an opening SOP might designate which building entrance is to be opened first, indicate where the intrusion detection system keypad and light switches are located, direct the sequential unlocking of specific emergency exit or other doors, specify where items needed during the procedure, such as flags, are to be found, and indicate which exhibit cases are to be checked.
- **How** the required actions must be performed or, as appropriate, may be performed. Unless there is a clear need for an action to be performed in a certain way, however, it is best to allow the responsible persons

flexibility in how they carry out their tasks. When an action must be performed in a certain way, as with operating an intrusion detection system or certain high-security locks, the SOP then should be as specific and detailed as necessary to ensure that it is done that way.

- **What** the results of the actions should be. For example, it is not sufficient to say something like "Check all exhibit cases." Instead, the SOP should say "Visually examine exhibit cases 4-13 for evidence of burglary or tampering during the night and for objects and graphics that might have fallen or come loose from their mounts. Inspect exhibit case access doors to ensure that they are still locked and that the locks are in good condition."

2. *Where do I find sample museum standard operating procedures and agreements?*

Figures G.3 through G.8 provide suggested format and language for park collection opening and closing procedures, access policies and procedures, and an agreement with a fire department. The sample documents are designed to cover all elements that normally need to be considered in most parks. You generally should follow the sample formats. However, the language may vary depending on your park's specific requirements and problems.

The electronic Museum Management Newsletter, issued by the NPS Museum Management Program, National Center for Cultural Resources Stewardship and Partnership publishes lists of park museum SOPs that are available upon request. Contact parks for copies of their SOPs. Some SOPs are available as WordPerfect files and can be furnished on disks or via cc:Mail either from the originating parks or your System Support Office (SSO).

3. *Where do I find additional help with preparing access policies and procedures?*

- MH-II, Appendix D, Museum Archives and Manuscript Collections
 - Section T. Providing Access to Archival and Manuscript Collections
 - Section U. Identifying Appropriate Restrictions for Archival and Manuscript Collections.
 - Section V. Implementing Access and Usage Policies for Archival and Manuscript Collections.
 - Section W. Monitoring and Tracking Researcher Use of Archival and Manuscript Collections
 - Figure D.16. Researcher Registration Form (Sample)
- MH-I, Chapter 6, Handling, Packing, and Shipping Museum Objects
 - Section C. General Rules for Handling Museum Objects

4. *Where do I find a sample visitor log?*

See Figure G.6 for a sample visitor log. An unpunched, full size visitor log accompanies this appendix. Keep the full size visitor log as a master and make copies for your use.

5. *Where do I find conditions for access to museum collections?*

See Figure G.7 for conditions for access to museum collections. An unpunched full size conditions for access to museum collections accompanies this appendix. Keep the full size document as a master and make copies for your use.

E. Mandates and Requirements for Emergency Management for Museum Collections

1. *What laws and regulations do I need to know?*

Emergency preparedness is addressed in a number of Federal laws and regulations. The focus of these laws and regulations is on protecting visitors or on broad, general issues of park management and resource protection. See U.S. Code Citations: USC 12 & 17; 16 USC 1a-6, 1b-1, and 3; 28 USC 1346 & 2672; and 31 USC 6483; and 36 CFR 1.5.

2. *What do the NPS Management Policies tell me?*

Chapter 5, Cultural Resource Management, requires:

- Emergency Management [Page 5:14]: "The emergency operations plan for each park with cultural resources will address their protection or rescue in the event of an emergency or disaster."

Chapter 8, Use of the Parks, outlines:

- Emergency Preparedness and Emergency Operations [Page 8:6]: "The National Park Service will develop a program of emergency preparedness in accordance with the Federal Civil Defense Act (50 USC 2251 et seq.), National Security Decision Directive 259 (Feb. 4, 1987), departmental policy, and other considerations at the Washington, region, and park levels. The purpose of the program will be to maximize visitor and employee safety and the protection of property. This program will include a systematic method for alerting visitors to potential disasters and evacuation procedures.

Superintendents may assist other agencies with emergencies outside parks. To the extent practicable, written agreements with such other agencies in accordance with the Federal Assistance and Interagency Agreements Guideline (NPS-20) must first be in effect. NPS employees who are outside the area of their jurisdiction and who are directed by their supervisors to provide emergency assistance to other agencies will be considered to be acting within the scope of their employment.

NPS emergency operations will be conducted utilizing the Incident Command System (ICS) of the National Interagency Incident Management System (NIMS). Each park superintendent will develop and maintain an emergency operations plan to ensure an effective response to all types of emergencies that can be reasonably anticipated."

3. *What NPS guidelines do I need to know?*

NPS-28, Cultural Resource Management Guideline, is the general guideline for protecting and managing all cultural resources, including museum objects.

- Chapter 4 provides general guidance on including cultural resources in the Emergency Operation Plan (EOP).

4. *What are the NPS standards for museum emergency management?*

- Chapter 9 states that the needs of collections are incorporated in emergency operation plans and that EOPs identify protection and recovery priorities for the most significant objects in the collection.
- Identify all disasters and other emergencies that could cause damage to or loss of the museum collection, in whole or in part.
- Include in the EOP a description of methods for protecting collections in time of emergency or write a separate museum emergency plan that describes such methods.
- Identify methods to mitigate against disaster-related damage, to the extent possible, and develop procedures for responding to and recovering from damages resulting from events that cannot be mitigated against.
- Stockpile emergency materials for use during and after a disaster and take other appropriate preparedness measures in anticipation of emergencies.
- Prioritize in the EOP museum objects according to their value and importance. Ensure that following a disaster, the most valuable or significant objects are given highest priority for emergency treatment.
- Ensure that secure on-site or off-site storage is available for protecting collections if regular storage or exhibit space becomes unusable following a disaster. Keep arrangements for the emergency use of non-NPS space such as freezer plants, current at all times.
- Establish cooperative or other agreements with local law enforcement, civil defense, and emergency response agencies, with other governmental and non governmental agencies, and with nearby NPS units regarding mutual aid in time of disaster.

F. Glossary

- **Air Sampling Smoke Detector:** A device that draws air through small diameter (generally less than 1/8") tubing into a detector unit that uses either the ionization, photoelectric, or cloud chamber principle to analyze the quantity of smoke or combustion products in the sample. (Also called Early Warning or Very Early Warning detectors.)
- **Arson:** The malicious burning of or attempt to burn property. Generally, an entire building will be affected rather than specific objects or property contained within.
- **Automatic Sprinkler System:** A network of overhead pipes with spaced outlets (sprinkler heads) that open at a predetermined temperature to discharge water onto a fire.
- **Barriers:** Tools for physical security designed to prevent, restrict, or delay access to a protected area or object.
- **Burglary:** Breaking and entering with the intent to commit a felony, usually theft, although vandalism also is common.

- **Capacitance Motion Detector:** A motion detector designed to detect motion close to a protected object, generally used to detect and discourage touching of high value exhibits, such as wall hangings or paintings. The device generates a capacitance field 4-6" from the protected object that detects any electrical conductor that enters the field.
- **Central Station:** A privately owned alarm monitoring system monitored by personnel who will report alarms to the police or fire department and to designated members of the staff of the protected site. A central station may be owned by the protected site (proprietary) or by a commercial business (commercial central station).
- **Civil Disturbances:** Disturbance of civil order and the peace. This activity may be organized or spontaneous; may be indiscriminate, involving the park as a consequence of its location, or discriminate, involving the park as a planned target; and may be a prelude to other criminal activity, especially vandalism and larceny and possibly robbery and assault.
- **Class A Fire:** A fire in ordinary combustibles (such as wood, paper, rubbish, and many plastics).
- **Class B Fire:** A fire in petroleum products, flammable gases and other flammable liquids (such as paints, thinners, and solvents).
- **Class C Fire:** A fire in energized electrical equipment and wiring, where the non-conductivity of the extinguishing agent is important.
- **Contact Switch:** A normally open or normally closed electrical switch that triggers an alarm when the switch changes position. Examples include magnetic door and window contacts, plunger switches, and roller or ball switches.
- **Crime Prevention:** Anticipating, recognizing, and appraising the risk of a crime and initiating actions to remove or reduce the risk.
- **Cycling Sprinkler System:** A sprinkler system similar to a Preaction System, except that a separate heat detection system both opens and closes the control valve at predetermined temperatures. After the valve closes, if the fire rekindles, it reopens and water again flows from the opened heads. The valve will continue to open and close in accordance with the temperature sensed by the heat detection system.
- **Dry Pipe Sprinkler System:** A sprinkler system used in areas where temperatures below 32° F are expected. Pipes are filled with air or nitrogen under pressure. When fire opens a sprinkler head, air pressure in the system drops, releasing a valve, letting water flow into pipes and discharge from the open sprinkler(s).
- **Dual Technology Motion Detector:** A motion detector that combines two detection technologies (such as microwave/passive infrared or ultrasonic/passive infrared) to minimize unwanted alarms. Both technologies must detect motion before the device signals an alarm.
- **Duress Alarm:** A personal protection device (also known as a panic or hold-up alarm) consisting of a manually operated switch that triggers a local or remotely monitored alarm to summon assistance.
- **Embezzlement:** Appropriating fraudulently to one's own use or benefit property entrusted to one's care. The property stolen might be sold (fenced) or retained for the personal use of the embezzler.
- **Fire Protection Survey:** A survey of fire prevention and personnel training programs, structural and procedural fire hazards, maintenance of protective systems, and overall effectiveness of the fire protection program.
- **Flame Detector:** Device that detects radiant energy (such as infrared, ultraviolet, or both) that may or may not be visible to the human eye, such as glowing embers or coals, as well as flames.

- **Glass Break Detector:** Device that detects breaking glass. There are two types: frequency discriminators and metallic foil or wire. Frequency Discriminators detect the high frequency sounds generated when glass breaks. Metallic Foil or Wire is a ribbon of lead foil or small wire that carries an electrical current. It is attached to the glass around the perimeter of a window so when the glass breaks, the foil or wire breaks, breaking the electrical circuit, causing an alarm.
- **Heat Detectors:** Heat-responsive devices either of the spot or line type, designed to respond when the operating element reaches a predetermined temperature (Fixed Temperature), when the temperature rises at a rate exceeding 15°F per minute (Rate-of-Rise), or when the temperature of the air surrounding the device reaches a predetermined level, regardless of the rate of temperature rise (Rate Compensation). Some have both fixed temperature and rate-of-rise features.
- **Industrial Disasters:** Involves an explosion, structural collapse, hazardous materials release, fire, a major accident, nuclear incident, major power outage or utility loss, and a serious break in water, sewer, or gas line.
- **Ionization Detectors:** A device that detects small combustion particles generated in the flame stage of a fire.
- **Larceny:** Unlawful taking or stealing of property or articles of value without the use of violence or fraud. There is a presumption that the property was not entrusted to the care of the person committing the theft. A presumption of theft also can be raised by possession of recently stolen property.
- **Line-Type Heat Detector:** A heat sensitive wire or tube, which triggers an alarm when the temperature in the protected space increases at a rate of 15°F, or greater, in a minute.
- **Line-Type (Photoelectric Beam) Smoke Detector:** A device that projects a beam of light (in the infrared range) to a receiver across an open area. The receiver measures light diffraction to detect smoke. These detectors often are used to protect large gallery-type spaces with high ceilings.
- **Local Alarm System:** A fire or intrusion detection system that causes an audible or visual alarm at the protected site, but which is not monitored off-site.
- **Magnetic Contact:** A detection device that uses a magnet mounted on a movable surface to open or close a contact switch mounted on a fixed surface.
- **Microwave Motion Detector:** A device that transmits electromagnetic energy in the microwave range (radar). The device measures the amount of energy reflected back to it and detects motion based on the doppler effect (a frequency shift that occurs as an object moves toward or away from the detector).
- **Natural Catastrophe:** Involves an earthquake, volcanic eruption, landslide, flood, hurricane, tornado, tidal wave, lightning, or wildfire.
- **On-Off Sprinkler Head:** A sprinkler head used on a standard wet-pipe system that makes the system act like a Cycling Sprinkler System. The difference is that each individual sprinkler head contains a temperature-sensitive device that opens the head at a predetermined temperature and closes it automatically when the temperature falls to a preselected point. Systems with on-off sprinkler heads operate independently of the fire alarm system.
- **Passive Audio or Sonic Sensors:** Audio and sonic sensors detect sound. An Audio Sensor is a sound activated microphone that transmits sounds from the protected space to a loud speaker in the monitoring station so the person monitoring the sensor hears what is going on in the protected space. Sonic Sensors are frequency discriminators that detect sound in the frequency range associated with movement.
- **Passive Infrared Motion Detector (PIR):** A device sensitive to infrared heat in the range generated by the average human body. The detector transmits no energy, but uses a series of heat sensitive elements to cover the protected area in a pattern of zones resembling the fingers on a hand. The device detects motion when a heat source moves from one detection zone to another. Everything has an infrared signature, and many mimic that of the human body (for example, a large animal or a radiant heater).

- **Photoelectric Beam Motion Detector:** A device with a transmitter that projects a beam of infrared light across an open space to a receiver. The receiver may be located directly across from the transmitter, or the light beam can be directed around the room with a series of small mirrors. Photoelectric beam devices may use just one beam or, to minimize unwanted alarms, several beams (stacked array).
- **Photoelectric Detector:** A device that detects large combustion particles in visible smoke.
- **Physical Security:** All measures intended to prevent acts of violence against persons and destructive or unauthorized access to, or removal of, property.
- **Preaction Sprinkler System:** A type of dry pipe sprinkler system with the water supply controlled by a fire detection system (either smoke or heat detection) wired so an alarm opens a valve to let water flow into the system piping. After the supply valve opens, the preaction system operates like a wet-pipe system.
- **Pressure Mat:** A pressure-sensitive mat, usually placed under a rug or carpet, to detect an intruder stepping into the protected space.
- **Probability:** The likelihood of a threat becoming an actual loss event.
- **Risk:**
 - **Conventional Risk:** A condition that entails both the possibility of loss and gain, such as investing in the stock market.
 - **Pure Risk:** A condition that is loss-only oriented. Among the pure risks that threaten park assets are crimes, natural disasters, civil unrest, and accidents.
- **Risk Assumption:** Using existing resources to absorb losses as and when they occur.
- **Risk Management:** The process of identifying, evaluating, and eliminating as many risks as possible by selecting and implementing effective countermeasures.
- **Risk Transfer:** The process of transferring a risk to another entity for a fee. A known cost, such as an insurance premium, may be substituted for the chance of a greater loss.
- **Robbery:** Theft by violence or threat of violence to one's person. Also included under this heading is the taking of a hostage to force someone on the museum staff to open the building or a secure area within the building.
- **Security:** Security includes all techniques, procedures, equipment and planning intended to prevent loss of or damage to collection objects from criminal activity, negligence, fire, or other catastrophic events.
- **Security Survey:** The National Institute of Law Enforcement and Criminal Justice describes the security survey as "a critical on-site examination and analysis of an industrial plant, business or home, public or private institution to ascertain the present security status; to identify deficiencies or excesses; to determine the protection needed; and to make recommendation to improve the security."
- **Severity:** The impact or effect upon the assets or upon the organization if a loss does occur.
- **Shoplifting:** A specific type of larceny that involves theft of merchandise for sale. This threat is a concern when there are sales operations within the park.
- **Spot-Type Smoke Detector:** A device that detects products of combustion by either the ionization or photoelectric principle, covering a defined area (generally no more than 900 square feet per detector in an open space with ceiling height less than 15 feet).

- **Standpipe System:** A piping system in a building to which hoses are connected for emergency use by building occupants or by the fire department. Standpipe systems intended for fire department use normally do not have hoses permanently attached; responding fire personnel provide the hose and use the standpipe connection to reduce the amount of hose they must carry into the building. Such systems may be charged with water by fire department pumpers. Standpipe systems intended for occupant use will have hoses, usually 1½ inches in size, already attached. Such systems usually are permanently charged with water.
- **Strain Sensor:** A device that detects the distortion that occurs on the under side of a joist, floor, or platform when weight is applied to the top surface.
- **Threat:** A potential to inflict harm or cause damage or loss.
- **Ultrasonic Motion Detector:** Similar to the microwave motion detector, except the device uses high frequency acoustic (sound) energy that will not penetrate solids.
- **Vandalism:** Willful or malicious destruction or defacement of objects, exhibits, or structures. This crime may be random and indiscriminate or directed toward a particular object, building, or exhibit. Vandalism is called sabotage if committed to hinder operations.
- **Vibration or Shock Detector:** A device that attaches directly to a protected object, an exhibit platform, or the structure of an exhibit case, which detects vibration, such as might occur when someone moves the protected object or strikes the protected exhibit case.
- **Warded Lock:** A lock with gates to which the correct key aligns to allow movement of the bolt and with internal wards, or obstructions, that block the entry or turning of an incorrect key.
- **Wet Pipe Sprinkler System:** A sprinkler system in which the piping permanently contains water.

G. List of Figures

Figure G.1	Sample Scope of Work for a Security Survey	G:15
Figure G.2	Sample Scope of Work for a Fire Protection Survey	G:20
Figure G.3	Sample Furnished Historic Structure Opening and Closing Procedures.....	G:25
Figure G.4	Sample Museum Collections Storage Opening and Closing Procedures.....	G:28
Figure G.5	Sample Park Museum Collection Access Policy and Procedures.....	G:29
Figure G.6	Sample Visitor Log	G:32
Figure G.7	Conditions for Access to Museum Collections.....	G:33
Figure G.8	Sample Memorandum of Understanding Between a Park and a Fire Company.....	G:34

SCOPE OF WORK
Museum Security Survey
[Park Name]

Purpose of Work

The work consists of conducting a museum security survey of the [facility/facilities] described below. There are two purposes for the survey. The first is to reveal and identify weaknesses in existing protection systems, equipment, procedures, policies, and operations that could result in the loss of such museum resources as collections, collection records, and exhibits, as well as the museum [structure/structures] [itself/themselves]. The second purpose is to identify alternatives to correct any weaknesses or deficiencies that may be found. The ultimate goal of performing the survey[s] and of implementing corrective actions is protecting museum property against all forms of losses.

Description of Site[s] to be Surveyed

[Here describe the buildings--visitor center, furnished historic structure, storage facility--to be surveyed. Characterize it/them in terms of location, size, functions, construction, and nature of contents. Provide whatever information is deemed necessary for the contractor to have in advance. In particular, indicate the nature of exhibits to be surveyed, making clear whether they are conventional exhibits or furnished rooms or both. In most cases, the Scope of Work (SOW) statement will become part of the request for proposal sent out to prospective contractors. It is important that prospective contractors have sufficient information about the site and facilities to be surveyed to permit them to make responsive proposals. You may wish to attach more detailed information, such as park brochures, to the SOW to avoid having to put a lot of detail in this section.]

Scope of Work

The Contractor will survey the structures or facilities described above, identify security weaknesses and deficiencies, and make recommendations for their correction in a separate formal report. [If more than one park is involved, you should request a separate report for each park. Only rarely might you specify a separate report for each structure in the same park.] The Contractor will visit and survey operations and conditions at [the site/each site] for [number of days]. In addition, the Contractor will return to [the site/each site] an additional one-half day to orally present his/her findings and recommendations to the site staff[s]. After completion of the return visit, the final report[s] will be revised as necessary based on comments made during the oral presentation and submitted to the park.

In carrying out this work, the Contractor will perform at a minimum the following tasks:

1. Prior to identifying himself/herself to the staff, tour public spaces in each of the specified facilities as an ordinary visitor and observe conditions and activities affecting protection of the collections and the structures. [If visitors normally have to pay a fee for admission to the site, indicate in this paragraph that fees paid will constitute a cost-reimbursable expense.]
2. Meet with management and staff at each site including [Here specify by title each of the site staff that the contractor must meet. At a minimum, the contractor should meet with the superintendent, the chief ranger, and the park curator.] [At each site other/Other] staff may be interviewed as deemed appropriate by the local manager or necessary by the Contractor and as may be arranged by the local staff.

Figure G.1. Sample Scope of Work for a Security Survey

3. Evaluate the physical security of each building in both public and non-public areas. Note problems with perimeters, including doors, windows, air intakes, roof hatches, and other penetrations. Evaluate perimeter lighting, locks, hardware, hinges, and other security equipment and devices. Evaluate the ease with which someone could penetrate the perimeter with or without being detected. Observe and evaluate perimeter security during the daytime and after dark. Before conducting surveys after hours, inform the local superintendent or site manager of when and how they will be carried out; that will preclude harm to the Contractor or site staff and ensure cooperation of staff on the night shift.
4. Examine and evaluate the electronic alarm systems, including controls, detectors, exhibit case sensors, panic devices, alarm and signaling devices, remote monitoring equipment, remote alarm transmission media (including line supervision), and other pertinent components. Test the proper functioning of the systems and evaluate their operation and maintenance. Evaluate [contract/proprietary] central station services (monitoring, response, premises security, and maintenance support).
5. Examine security staffing for adequacy. Review staffing levels, position descriptions, performance standards, standard operating procedures, training, and delegations of responsibility for all personnel and staff components directly responsible for museum security. Evaluate protection of all areas by security personnel. Review the scheduling and conduct of security patrols. Evaluate adequacy of protection provided by interpreters during interpretive tours or programs. Evaluate the interpretive operations plan in respect to how well it incorporates security concerns into the responsibilities of interpreters. If guards are used on the night shift, evaluate their effectiveness and response capabilities and the extent to which they may be vulnerable to personal injury, attack, or accident during their rounds.
6. Evaluate security training or security awareness programs provided at the site for both security and non-security personnel.
7. Evaluate policies for and staff compliance with access and parcel controls in use at the site[s], particularly in office and work areas, in exhibit areas, and in collections storage.
8. Evaluate security policies and procedures, including standard operating procedures, delegations of authority, and memoranda of agreement or understanding with local police and emergency agencies.
9. Evaluate key control and retrieval. Evaluate the adequacy of locking systems, key documentation, and key security. Determine whether card access or similar control systems would be appropriate and practical for securing or controlling access to buildings and to high-security areas, such as collections storage.
10. Evaluate internal security programs, particularly procedures to account for objects taken outside of collection storage and exhibit areas, such as in offices and workrooms or in transit.
11. Evaluate security for objects on exhibit and in storage, including case design, security hardware, detection systems, locks, keying, accountability procedures, and other internal control procedures and systems. In particular, evaluate the ease with which objects may be stolen from exhibits [and furnished rooms] without immediate detection of the act. Evaluate the ease with which objects on exhibit [and in furnished rooms] may be vandalized, with or without immediate detection.

Figure G.1. Sample Scope of Work for a Security Survey (continued)

- 12 *[This paragraph is needed only when historic structures are to be surveyed.]* All recommendations for improvements to or replacements of systems and hardware will take into account and be sensitive to the historic nature of the structure[s]. As appropriate, alternative recommendations for equipment and/or installation techniques will be made to allow for maximum preservation of historic fabric.
- 13 Evaluate the timeliness, effectiveness, and accuracy of how the [site/sites] report[s] criminal or other incidents involving collections.
- 14 Observe and comment on other security problems that may be noted during the survey[s]. Evaluate park policies and documentation for all security procedures not otherwise specified above.

Standards

The following published documents shall be considered the standards against which Contractor shall evaluate security at the site[s]. The first [qty] items are available for loan to Contractor upon request. The remaining items are standard industry publications, which should already be available to Contractor.

[Here list relevant documents, such as: NPS Museum Handbook, Part I; NPS-28 "Cultural Resource Management Guideline"; NPS-44 "Personal Property Management Guideline"; NPS-50 "Loss Control Management Guideline"; NPS Management Policies; Special Directive 80-1 and NPS Checklist for Preservation and Protection of Museum Collections; and any other NPS documents that may be relevant. List the American Society for Industrial Security (ASIS) Suggested Guidelines in Museum Security; and other industry publications.]

Protection of Information

All information and documentation gathered or produced by the Contractor during the course of this work shall be held in strictest confidence and shall be fully protected from access by unauthorized persons. Any documentation furnished by the site[s] and retained by the Contractor during the course of the work or thereafter shall be secured in a locked filing cabinet or safe at a minimum. During the initial visit to the site[s], the Contractor shall indicate to the superintendent[s] the manner in which he/she intends to secure any documentation the site[s] may furnish; the superintendent[s] will have the prerogative to specify when more stringent security must be provided for any particular documentation furnished to the Contractor. Documentation that cannot be secured to the superintendent's[s'] satisfaction still will be furnished to the Contractor, but only for on-site use.

Notes and other information produced by the Contractor, including all versions and copies of his/her report and any drawings that may be produced, shall be secured in a locked filing cabinet or safe, at a minimum. Word processor and other computer files shall be secured in an equivalent manner, such as by retaining files only on diskettes kept in a safe, rather than on a hard drive, and by the use of passwords or encryption. During the initial visit to the site[s], the Contractor shall indicate to the superintendent[s] the manner in which he/she intends to secure computer data generated during the course of the work; the superintendent[s] will have the prerogative of specifying that additional security measures be taken whenever circumstances so dictate.

Figure G.1. Sample Scope of Work for a Security Survey (continued)

Products, Deliverables, and Performance

1. Contractor should discuss his/her findings and recommendations with protection and museum staff at [the/each] site during the initial visit[s], and is encouraged also to discuss recommendations for corrective actions, but is not obliged to do so. Contractor has an ethical obligation to verbally point out serious protection weaknesses as they are encountered, if such weaknesses could, in his/her judgment, result in imminent loss of park resources.
2. Contractor shall prepare and submit a written report of survey [*for each site visited*]. The report shall present findings and recommendations for each applicable subject listed above in the Scope of Work and shall be organized in a logical, easily comprehended manner. [*The/Each*] report shall include an executive summary, a discussion of observations and problems (organized according to areas within [*the/each*] structure or according to each security issue, e.g., training, staffing, and hardware), a list of recommendations and possible alternative solutions for problem areas, a comprehensive prioritized list of recommendations, a list of recommended suppliers of security hardware and systems and cut sheets or other manufacturer's literature on recommended hardware or system components, and a bibliography of recommended readings on the specific protection problems and solutions presented in the report[s].
3. Submit draft reports to the park according to the schedule below. Reports will be reviewed promptly and returned with comments. Contractor will be expected to incorporate each comment into the report or be prepared to explain why doing so is not appropriate.
4. After approval of the second draft, return to [*the/each*] park for a followup visit. Orally present findings and recommendations to the assembled park staff. Orally respond to questions, comments, and concerns from the staff. [*The/Each*] presentation[s] should include a walk-through of the surveyed [*facility/facilities*] as necessary to make findings and recommendations clear. In order to ensure sufficient time for the presentation[s], [*it/they*] should be scheduled to allow for one-half day [*per site*].

Time for performance is [*number of months*]. [*The*] Initial site visit[s] must be completed within [*number of days*] from award of contract. The final report must be completed within [*number of days*] after completion of the initial visit[s]. [*The following schedule of completion is suggested. Modify as instructed by your contracting officer.*]

<u>Work Element</u>	<u>Completion Time After Award</u>
Initial site visits	[<i>number of days</i>]
Submit first draft of report[s] to park	[<i>number of days</i>]
Correct report[s] by Contractor	at Contractor's discretion

Figure G.1. Sample Scope of Work for a Security Survey (continued)

<u>Work Element</u>	<u>Completion Time After Award</u>
Followup site visit[s] and present report[s] to park staffs	[number of days]
Complete final report[s]	at Contractor's discretion
Submit final report[s] to park staffs	[number of days]
<u>Schedule of Partial Payments</u>	
Partial payments will be made upon successful completion of each successive phase of the work, as outlined below:	
Initial site visit[s]	50%
Submit second draft[s] of report[s]	25%
Submit final report[s]	25%
<u>Inspection and Acceptance</u>	
[Insert Name and Title] shall serve as the Contracting Officer's Technical Representative (COTR) on this project. The COTR is empowered to inspect and evaluate all work of this Contract for compliance with terms of this Scope of Work Statement.	
Acceptance of the work of this contract and any changes to the terms of this contract shall be made in writing only by the Contracting Officer.	

Figure G.1. Sample Scope of Work for a Security Survey (continued)

SCOPE OF WORK
Fire Protection Survey
[Park Name]

Purpose of Work

The work consists of conducting a museum fire protection survey of the [facility/ facilities] described below. There are two purposes for the survey. The first is to reveal and identify weaknesses in existing protection systems, equipment, procedures, policies, and operations that could result in the loss of such museum resources as collections, collection records, and exhibits, as well as the museum [structure/structures] [itself/themselves]. The second purpose is to identify how to correct any weaknesses or deficiencies that may be found. The ultimate goal of performing the survey[s] and of implementing corrective actions is the protection of museum property against all forms of losses due to fire or to fire fighting activities.

Description of Site[s] to be Surveyed

[Here describe the buildings--visitor center, furnished historic structure, storage facility--to be surveyed. Characterize it/them in terms of location, size, functions, construction, nature of contents. Provide whatever information is deemed necessary for the contractor to have in advance. In particular, indicate the nature of exhibits to be surveyed, making clear whether they are conventional exhibits or furnished rooms or both. In most cases, the scope of work (sow) statement will become part of the request for proposal sent out to prospective contractors; it is important that prospective contractors have sufficient information about the site and facilities to be surveyed to permit them to make responsive proposals. You may wish to attach more detailed information, such as park brochures, to the SOW to avoid having to put a lot of detail in this section.]

Scope of Work

The contractor will survey the structures or facilities described above, identify fire prevention, detection, and suppression weaknesses and deficiencies, and make recommendations for their correction in a separate formal report. *[If more than one park is involved, you should request a separate report for each park. Only rarely might you specify a separate report for each structure in the same park.]* The contractor will visit and survey operations and conditions at [the site/each site] for [number of days]. In addition, the contractor will return to [the site/each site] an additional one-half day to orally present his/her findings and recommendations to the site staff[s]. After completion of the return visit, the final report[s] will be revised as necessary based on comments made during the oral presentation and submitted to the park.

In carrying out this work, the contractor at a minimum will perform the following tasks:

1. Meet with management and staff at each site including *[Here specify by title each of the site staff that the contractor must meet. At a minimum, the contractor should meet with the superintendent, the chief ranger, the chief of maintenance, the structural fire coordinator, and the park curator.]* *[At each site other/Other]* staff may be interviewed as deemed appropriate by the local manager or as necessary by the Contractor and as may be arranged by the local staff.
2. Evaluate fire prevention policies, programs, and procedures in each building in both public and non-public areas. Examine existing policies and the extent to which they are appropriate to the resources being protected and actually are being followed. Examine the effectiveness of programs and procedures in preventing fires from starting.

Figure G.2. Sample Scope of Work for a Fire Protection Survey

3. Examine and evaluate fire detection and alarm systems, including sensors and detectors, manual pull stations, water flow and position indicating alarms, system controls, standby power, alarm and signaling devices, remote monitoring and annunciation equipment, remote alarm transmission media (including line supervision), and other pertinent components. Determine the extent to which systems comply with current National Fire Protection Association (NFPA) standards for the installation, operation, maintenance, and testing of fire alarm signaling systems (NFPA 72, National Fire Alarm Code). Report on the extent to which system components are listed by Underwriters Laboratories (UL). Test the proper functioning of the systems and evaluate their operation and maintenance. Evaluate [contract/proprietary] central station services (monitoring, response, premises security, and maintenance support).
4. Examine and evaluate the types, sizes, locations, etc. of hand-held fire extinguishers currently in use in the [facility/facilities] being surveyed. Determine whether different types or sizes would be more appropriate and whether existing extinguishers should be relocated or augmented with additional extinguishers. When extinguishers are concealed for aesthetic reasons, determine whether concealment poses the potential for such problems as delayed access or failure to use an otherwise available extinguisher. Evaluate procedures, programs, and schedules for testing fire extinguishers; determine whether proper records are created and maintained when extinguishers are tested.
5. Examine and evaluate the appropriateness, capacity, spacing, temperature rating, and hazard rating of fixed sprinkler systems. Examine and evaluate hose and standpipe systems inside the [facility/facilities] being surveyed. Examine and evaluate the suitability and locations of fire hydrants near the [facility/facilities] being surveyed. Determine whether different types or sizes of automatic and manual suppression systems would be more appropriate and whether additional units are required. Determine if water supplies provide the necessary flow rate and volume. Examine the maintenance and protection of fire department connections and the protection of water supply control valves.
6. Examine the adequacy of current staff in respect to their ability to prevent, detect, respond to, and suppress fires. Review staff size, position descriptions, performance standards, standard operating procedures, training, and delegations of responsibility for all personnel and staff components directly responsible for any aspect of fire protection. Determine the adequacy of fire patrols and of those aspects of facility closing procedures that are intended to prevent after hours fires. Evaluate adequacy of protection provided by interpreters during interpretive tours or programs. Evaluate the interpretive operations plan in respect to how well it incorporates fire prevention or awareness concerns into the responsibilities of interpreters. If guards or patrols are used at night, evaluate their effectiveness and the extent to which they are able to detect fires and provide or summon appropriate response.
7. Evaluate training provided to the [site's/sites'] fire brigade[s] and general staff fire protection awareness programs provided at the [site/sites]. Determine whether the right staff are being trained. Determine the extent to which training requirements of NPS-58, Structural Fire Guideline, Chapter 7, are being met. In particular, examine training in the use of hand-held fire extinguishers and fire hoses.
8. Evaluate fire suppression policies and procedures, including standard operating procedures, delegations of authority, and memoranda of understanding with local fire and emergency agencies for fire inspection or suppression services. Memoranda must comply with NPS-58 and with applicable federal regulations.

Figure G.2. Sample Scope of Work for a Fire Protection Survey (continued)

9. Evaluate pre-fire planning and the extent to which such planning is in accordance with NPS-58, Chapter 6. In particular, examine whether pre-fire planning takes into account the special needs of museum objects, records, exhibits, storage areas, and work spaces, as noted on pages 1 and 3 of Chapter 6. Also determine whether pre-fire planning strikes a proper balance between protecting museum resources and the structures housing them. *[When historic structures are involved, you may wish to strengthen this paragraph by adding the issue of protecting historic structures themselves.]*
10. Determine quality of the structural fire inspection programs and extent of compliance with NPS-58, Chapter 5.
11. Evaluate the timeliness, effectiveness, and accuracy of post-fire investigation and reporting. Evaluate reporting in terms of requirements set forth in NPS-58, Chapters 11 and 12.
12. *[This paragraph is needed only when historic structures are to be surveyed.]* All recommendations for improvements to or replacements of systems and hardware will take into account and be sensitive to the historic nature of the structure[s]. As appropriate, alternative recommendations for equipment and/or installation techniques will be made to allow for maximum preservation of historic fabric.
13. Observe and comment on other fire protection problems that may be noted during the survey[s]. Evaluate park policies and documentation for all fire prevention, detection, and suppression procedures not otherwise specified above.

Standards

The following published documents must be considered the standards against which Contractor shall evaluate security at the site[s]. The first [qty] items are available for loan to Contractor upon request. The remaining items are standard industry publications which should already be available to Contractor.

[Here list relevant documents, such as: NPS Museum Handbook, Part I; NPS-28, Cultural Resources Management Guideline; NPS-58, Structural Fire Guideline; NPS Management Policies; Special Directive 80-1 and NPS Checklist for Preservation and Protection of Museum Collections; and any other NPS documents that may be relevant. List National Fire Protection Association (NFPA) and Factory Mutual (FM) guidelines; fire protection industry publications.]

Products, Deliverables, and Performance

1. Contractor should discuss his/her findings and recommendations with administrative and resources management staff at [the/each] site during the initial visit[s], and is encouraged to also discuss recommendations for corrective actions. Contractor has an ethical obligation to verbally point out serious protection weaknesses as they are encountered, if such weaknesses could, in his/her judgement, result in imminent loss of park resources.
2. Contractor shall prepare and submit a written report of survey [for each site visited]. The report shall present findings and recommendations for each applicable subject listed above in the Scope of Work and shall be organized in a logical, easily comprehended manner. [The/Each] report shall include an executive summary, a discussion of observations and problems (organized according to areas within [the/each] structure or according to each fire protection issue, e.g., training, staffing,

Figure G.2. Sample Scope of Work for a Fire Protection Survey (continued)

hardware), a list of recommendations and possible alternative solutions for problem areas, a comprehensive prioritized list of recommendations, a list of recommended suppliers of fire protection hardware and systems and cut sheets or other manufacturer's literature on recommended hardware or system components, and a bibliography of recommended readings on the specific protection problems and solutions presented in the report[s].

3. Submit draft reports to the park according to the schedule below. Reports will be reviewed promptly and returned with comments. Contractor will be expected to incorporate each comment into the report or be prepared to explain why doing so is not appropriate.
4. After approval of the second draft, return to *[the/each]* park for a follow-up visit. Orally present findings and recommendations to the assembled park staff. Orally respond to questions, comments, and concerns from the staff. *[The/Each]* presentation[s] should include a walk-through of the surveyed *[facility/facilities]* as necessary to make findings and recommendations clear. In order to ensure sufficient time for the presentation[s], *[it/they]* should be scheduled to allow for one-half day *[per site]*.

Time for performance is *[number of months]*. *[The]* Initial site visit[s] must be completed within *[number of days]* from award of contract. The final report must be completed within *[number of days]* after completion of the initial visit[s]. *[The following schedule of completion is suggested. Modify as instructed by your contracting officer.]*

<u>Work Element</u>	<u>Completion Time After Award</u>
Initial site visits	<i>[number of days]</i>
Submit first draft of report[s] to park	<i>[number of days]</i>
Correct report[s] by Contractor	at contractor's discretion
Submit second draft of report[s] to park	<i>[number of days]</i>
Correct report[s] by Contractor	at contractor's discretion
Followup site visit[s] and present report[s] to park staffs	<i>[number of days]</i>
Complete final report[s]	at contractor's discretion
Submit final report[s] to park	<i>[number of days]</i>

Figure G.2. Sample Scope of Work for a Fire Protection Survey (continued)

Schedule of Partial Payments

Partial payments will be made upon successful completion of each successive phase of the work, as outlined below:

Initial site visit[s]	50%
Submit second draft[s] of report[s]	25%
Submit final report[s]	25%

Inspection and Acceptance

The [*Insert Name and Title*] shall serve as the Contracting Officer's Technical Representative (COTR) on this project. The COTR is empowered to inspect and evaluate all work of this Contract for compliance with terms of this Scope of Work Statement.

Acceptance of the work of this contract and any changes to the terms of this contract shall be made in writing only by the Contracting Officer.

Figure G.2. Sample Scope of Work for a Fire Protection Survey (continued)

NATIONAL PARK SERVICE

[Park's Name]

To: All Park Personnel

From: Superintendent

Subject: Opening and Closing Procedures for [Structure's Name]

Purpose: To establish responsibilities for security and daily opening and closing procedures of [Structure's Name].

Policy: Park personnel assigned to [Structure's Name] will follow established guidelines to ensure proper security of the site and protection of the resource.

Guidelines:

The intrusion detection system will be activated during all non-business hours. Generally this is from 4:30 PM to 7:30 AM daily. Hours may vary slightly on weekends.

On days when it is not open to the public, the Curator is responsible for arming the intrusion detection system at the end of the workday. On days when the furnished historic structure is open to the public, it is the responsibility of the interpretive staff to arm the system. Generally the furnished historic structure is open on weekends and [days] during the summer.

Each morning, it is the responsibility of the Park Ranger staff to disarm the intrusion detection system. The guards on duty will turn off the systems during the early morning patrol at about [Time].

It is the responsibility of the Curator and custodian to maintain security on days when the house is not open to the public. Exterior doors should remain locked at all times and the house should be secured and alarmed at the end of each workday.

It is the responsibility of the Interpretive staff to secure the structure on weekends and on other days that the furnished historic structure is open to the public. The closing procedures should include inspecting the entire furnished historic structure, not just the areas used by the public.

The evening ranger patrol will include an inspection to ensure that the structure has been properly secured. Before entering, the park ranger will patrol around the exterior of the furnished historic structure shining the flashlight on each of the windows to ensure that they are closed. Only if all appears secure, will the ranger enter the structure alone to complete the inspection.

Closing Procedures:

The following steps are taken by designated interpretive or museum staff. As you walk through the house, note maintenance or safety concerns or questions about museum object security.

1. Ensure that visitors are out of the house. Record tour and visitation statistics when the house has been open to the public.

Figure G.3. Sample Furnished Historic Structure Opening and Closing Procedures

2. Place the moveable "entrance" signs inside the Conservatory when the house has been open to the public.
3. Lock all exterior doors. Exterior doors are located in:
 - Conservatory (2 doors)
 - Front entrance
 - Atrium or Small Conservatory
 - Den
 - Kitchen Pantry Hall
 - Servants' Hallway
4. Close all windows and fasten those that can be locked. Check windows in the Conservatory and on all three floors of the house.
5. Pull down the window shades as you check each window.
6. Put the two tripods with fire detectors in their proper position in the Foyer and the Dining Room. Poles should be extended so the detector heads are as close to the ceiling as possible.
7. Close the following interior doors:
 - Front double doors (dead-bolted top & bottom & chained)
 - Basement electrical room
 - First floor Servants' Hall door to Basement
 - Second floor hall door between Servants' Wing and Staircase (Intrusion alarm does not arm properly if they are open.)
 - Basement Furnace Room
 - Third floor door to Attic stairs
8. Close the following interior doors, if possible:
 - All basement room doors except fire control panel room
 - Both doors to China Storage area
 - Servants' Hall door to Front Foyer(NOTE: Closing these doors reduces the chances for false alarms.)
9. Leave night lights on in the following areas:
 - Laundry Room, above the sinks
 - Kitchen, above the sink
 - Servants' Hall, above the radiator
 - Dining Room, one light on each of the two sconces
 - Entrance Hall, inner chandelier globe. (NOTE: The switch is in closet.)
 - Second floor Servants' Hall staircase
10. Activate the two intrusion detection system panels in the Laundry Room. Remember the Servants' Wing exit must be closed before the system is armed. Exit the house through the Servants' Wing door.
11. Make a final patrol around the outside of the house to check doors and windows. Do not jiggle doors or windows from the outside. (Doing so might cause an intrusion alarm.)

Figure G.3. Sample Furnished Historic Structure Opening and Closing Procedures (continued)

Opening Procedures:

Intrusion detection systems are disarmed each morning by the park ranger staff. The systems will be off prior to the time that other park staff need to enter the house.

1. Before entering, walk around the outside of the house and check for signs of entry. If anything looks suspicious do not enter. Report the observation to the protection staff immediately.
2. Enter through the Servants' Wing door. Lock the door behind you.
3. Check the status lamps and alarms on both alarm system panels in the Laundry Room and report any malfunctions.
4. Make a walk-through visual inspection of the entire house, including the basement and upper floors. Make particular note of signs of attempted entry, safety or maintenance needs, and the location of museum objects. Report concerns or problems to the appropriate protection or museum staff.
5. Take down the two portable fire detectors in the Foyer and Dining Room, when the house is open to the public. Place them in the Hall Closet.
6. Prepare the rooms along the tour route by opening shades and turning on the appropriate lights, if the house is to be open to visitors. Make a special note of safety and security concerns in these visitor use areas.
7. Prepare for greeting visitors by placing the entrance signs outside. Establish tour assignments, prepare the visitor statistic sheet and ensure that a supply of park folders is available.
8. In summer, when temperatures are hot, visitors will enter through the front door. When weather is cool, the Conservatory will be opened as a waiting area for visitors. If the Conservatory is to be opened, clean up the room, place literature out on display, and unlock both exit doors from the room.
9. Call the Park's Visitor Center desk to let them know that the house is ready for visitors and to check for any special tours or activities.
10. Throughout the day, be certain that all doors into the house are locked unless you can observe them. Generally, the only doors that should be unlocked during the day are those in the Conservatory when it is being used as a visitor waiting area.

Figure G.3. Sample Furnished Historic Structure Opening and Closing Procedures (continued)

NATIONAL PARK SERVICE
[Park's Name]

To: All Park Personnel

From: Superintendent

Subject: Opening and Closing Procedures for [*Storage Facility's Name*]

Purpose: To establish responsibilities for security, fire prevention and daily opening/closing procedures for the park's museum collection storage facility.

Policy: Park personnel who are assigned responsibility for the park's museum collection are required to follow the established guidelines to ensure the proper security of the site and protection of the resources.

Guidelines

Opening Procedures:

1. Before entering the facility, check for any unusual circumstances (e.g., signs of illegal entry, vandalism or maintenance problems). If anything looks suspicious **DO NOT ENTER**. Report any problems to the appropriate staff person in law enforcement, maintenance and/or supervisor immediately.
2. Unlock exterior doors. Turn off the intrusion detection system.
3. Turn on museum workspace lights.
4. Unlock collection storage space door (when needed) and turn on lights.
5. Inspect museum workspace and collection storage space for unauthorized entry, fire hazards, or other unusual happenings (such as roof leaks, fire suppression system leaks, pests, and damaged objects).

Closing Procedures:

1. Inspect the collection storage space to be sure all museum objects and associated records are returned to their proper locations; dust covers are in place; all storage cabinets are closed and locked, and that all tools, equipment, reference books have been returned to their proper places.
2. Check that all museum storage cabinets that were used during the day are locked. Return all storage cabinet keys to keybox and secure it.
3. Check the workspace and collection storage space to be sure that all staff or any other persons are out of the facility.
4. Turn off lights. Make sure that collection storage space door is locked.
5. Turn off all computer equipment, other electrical equipment, and lights in adjacent office spaces.
6. Lock windows in office spaces.
7. Turn on the intrusion detection system.
8. Lock exterior doors.

Figure G.4. Sample Museum Collections Storage Opening and Closing Procedures

NATIONAL PARK SERVICE

[Park's Name]

To: All Park Personnel

From: Superintendent

Subject: Museum Collection Access Policy and Procedures

Purpose: To establish park policy and procedures for access to the museum collection. It is the policy of the National Park Service, and of *[Name of Park]*, that its natural and cultural resources shall be made available for educational and research purposes, as long as this access doesn't:

- endanger the item's preservation and security
- conflict with Federal legislation (such as the Copyright Act, the Freedom of Information Act) or state legislation (such as privacy and public laws)

NPS museum collections possess internal administrative importance, as well as importance to educational, research, and publishing communities both inside and outside the Service. Protecting these valuable resources, while making them available to the widest possible audience, requires the park museum staff to manage access to the museum collection.

Times of Operation: Normal hours of access to the park's museum collection are *[Days and Hours]*.

General Access Procedures:

1. Except as otherwise noted, this written procedural statement applies equally to museum objects, archival and manuscript materials, museum collection records, and information about such park resources prepared by the staff in the course of their official duties.
2. Access to objects in the collection, to storage cabinets and exhibit cases, and to keys to locks on storage rooms, storage cabinets, and exhibit cases, will be strictly controlled by the Superintendent or designee. These areas shall be designated as secure areas, and except for emergencies, access shall be limited to authorized park staff. Park staff are discouraged from routinely using museum storage space as work or reference room space.
3. Only those persons authorized in writing by the superintendent (authorized park staff) will be permitted unaccompanied access to secure areas, including museum storage, work, and reference/study room spaces, under normal conditions. All other persons must be accompanied by authorized staff while in a secure area. In an emergency, designated emergency response personnel may have access to secure areas in accordance with the provisions of the park's Emergency Operations Plan. An authorized person will continuously supervise anyone in a secure area who is not on the list of authorized park staff.
4. Granting of access to a secure area does not automatically include access to museum objects, archival materials, or museum records kept in those areas. Only persons with a legitimate need to use collection items will be granted access to them.
5. Anyone requesting access to secure areas or to museum collections must agree to comply with the provisions of the park's "Conditions for Access to Museum Collections."
6. These procedures will be reviewed every two years and revised as necessary.

Figure G.5. Sample Park Museum Collection Access Policy and Procedures

Eligibility for Access to Museum Collections:

Access to the collections should be granted by the Superintendent or designee to the following individuals:

1. **Individuals seeking to use collection for research or study.** An individual may request to conduct research on the collection by registering and making an appointment with the park museum staff.
2. **National Park Service staff from the Field Area Office, System Support Office, the Washington Office, centers, or other parks who are visiting the park on official business.** The nature of their work must require them to evaluate, inspect, or work with the collections or the rooms, cabinets, or cases housing the collections or with park records on the collections. Persons granted access under this category of eligibility do not necessarily have to be accompanied by park staff at all times; a decision in that respect will be based on their reasons for needing access and on other factors that the Superintendent may consider germane at the time.
3. **Representatives of Indian Tribes or Native Hawaiian organizations having official business with the park staff for examining archeological or ethnographic objects in the collections.** The Superintendent should ascertain if the individuals are official tribal representatives. Under this category, individuals will have access to collections associated with their own tribes.
4. **Non-museum park employees, including volunteers, who are being oriented to the park and their work or who require access to collections as part of their internal training.**
5. **Park maintenance and protection staff in the performance of their official duties.** Except in the most unusual circumstances, such personnel shall have access only to rooms in which collections are kept, not to storage cabinets or exhibit cases or to key boxes or other places where keys to cabinets and cases are secured. As provided below, other means shall be made available to these personnel for emergency access. Persons granted access under this item of eligibility do not necessarily have to be accompanied by curatorial staff, but should be whenever possible.
6. **Individuals or representatives of organizations, institutions, or corporations desiring to use objects or records in the collection for commercial or publicity purposes.** Such persons must satisfy the Superintendent that their purposes are legitimate and that the proposed uses are in keeping with park purposes and the NPS mission and will not reflect adversely on the park, the National Park Service, or a Native American tribe, if the request is for tribal materials. Access should not be granted solely on the grounds that access to the park's collection would be more economical or "easier" for them than access to another collection. When the park provides access, it is not authorizing publication, distribution, derivative works, exhibitions, reproductions, or other non-research activity.
7. **Employees of construction or service companies who require access to collection storage or exhibit areas in order to service or maintain the building or its utilities, including alarm systems.** Such persons will be allowed access only under the terms of a contract or purchase order issued by or for the park and only to those areas where they are supposed to work. Under no circumstances shall such persons be allowed unsupervised access to objects kept in storage cabinets and exhibit cases. Except as may be

Figure G.5. Sample Park Museum Collection Access Policy and Procedures (continued)

otherwise provided in the language of the contract or purchase order, all persons granted access under this item of eligibility must be accompanied at all times by authorized staff. The Superintendent or designee shall have the authority to restrict access otherwise granted by this paragraph, under such circumstances where it is deemed advisable.

8. **Other persons or groups of persons may be allowed limited access to the collections, on determination by the Superintendent or designee that such access will be to the mutual benefit of the persons or groups and the park.** Examples of circumstances to which this item of eligibility might apply include: tours for school classes, tours for members of museum organizations or historical societies, tours for families of park employees, orientation for local political/ governmental officials, orientation for visiting Park Service employees not on official business, and tours for non-NPS museum personnel, teachers, and prospective researchers who are considering applying for permission to use or view the collection.

Figure G.5. Sample Park Museum Collection Access Policy and Procedures (continued)

U.S. Department of the Interior
National Park Service

VISITOR LOG

By signing this visitor log I acknowledge that I have read and agreed to conditions listed on the reverse of this log.

DATE	TIME IN TIME OUT	NAME (Print) (Signature)	ORGANIZATION (Name, Address, Telephone Number)	AREA AND ITEMS OF INTEREST
-------------	-----------------------------	-------------------------------------	---	---------------------------------------

Figure G.6. Sample Visitor Log

**U.S. Department of the Interior
National Park Service**

CONDITIONS FOR ACCESS TO MUSEUM COLLECTIONS

1. Access to collections and/or to a secure area by researchers is by appointment. Any limitations imposed on access due to collection conditions, staff availability, and security considerations must be imposed equally on all users, including park staff's personal research. Persons needing to have access are urged to make their requests known to the Superintendent or designee as far in advance as possible.
2. Prospective visitors should be aware that the park staff is extremely busy at certain times of the year and that authorized staff may not be available to assist them at those times. Accordingly, it is suggested that persons needing access make an appointment and be prepared to discuss alternative times with the staff when they submit their requests.
3. The park's decision to allow access may depend upon the condition of the materials, the availability of space for the requester to work, and appropriate supervisory staff. The park keeps space and staff available for visiting researchers.
4. The park requires registration of all researchers (including those inquiring through the mail, on the phone, or Internet). Registration information needs to include full name, address, telephone number(s), institutional affiliation, research topic and publication plans. This information must be updated yearly to remain valid. A valid picture identification card must be shown at the time of the visit. All materials requested by the user are recorded.
5. All non-staff visitors and all staff visitors who are not designated as authorized staff will be accompanied at all times by authorized staff when in museum collection storage areas, when working in open exhibits, or when working with original museum and archival materials.
6. All visitors must sign in and out of museum collection storage area(s) and reference/study rooms on the park's "Visitor Log."
7. Smoking, drinking, and eating are prohibited in collection storage and work spaces and reference/study rooms. Suitcases, briefcases, overcoats, plants, and animals, except guide dogs, are not allowed in collection storage and study areas. Researchers must use pencils/paper or portable computers for taking notes.
8. All guidelines for handling objects and archival and manuscript materials must be read and signed by all collection users, whether staff or non-staff. These guidelines are published separately and may be requested in advance of a visit. A copy of the guidelines also will be provided to each user at the time he/she arrives.
9. The park reserves the right to the following as a condition for granting access to the collections:
 - a. The researcher must agree to abide by any copyrights and state privacy and publicity legislation as well as duplication, publication, and citation policies.
 - b. The park, as a courtesy, requests two copies of completed research papers; publications; CD-ROMs; screen captures of World Wide Web work, derived from work on the collections, or which contain photographs of objects in the collections or copies of documents in the archival collections. Copies of formal reports and other published materials shall be provided at the researcher's expense. Copies of drawings, photographs, and other products of research shall be provided at the researcher's expense, except when doing so constitutes an economic burden, in which case the Superintendent can elect to defray those costs or waive the requirement for the researcher to provide the materials.

Figure G.7. Conditions for Access to Museum Collections

MEMORANDUM OF UNDERSTANDING

BETWEEN

[Name of Park]

and

[Name of Fire Company]

[City, State]

Article I

Background and Objectives

WHEREAS, *[Name of Fire Company]* hereinafter *[Department/Company]* and the National Park Service (hereinafter Service) and more particularly the *[Name of Park]*, hereby enter into an Agreement to provide mutual aid and assistance for occurrences of structural fires, *[As applicable, insert language to identify other needs, such as wildfires, emergency medical services and hazardous materials spills for those occurrences]* on or within the boundary of said Park, a unit of the National Park System, United States Department of the Interior, that are within the response area of the *[Name of Fire Company]*; and

WHEREAS, pursuant to 16 U.S.C. 450bb, the Service administers the Park that was established as a unit of the National Park System, United States Department of the Interior; and

WHEREAS, pursuant to 16 U.S.C. 1b.(1), the Service may provide for the rendering of emergency rescue, fire fighting and cooperative assistance to nearby fire prevention agencies and for related purposes outside of the National Park System; and

WHEREAS, pursuant to 42 U.S.C. 1856a, the Service is authorized to enter into reciprocal agreements for mutual aid to furnish fire protection with any fire organization maintaining fire protection facilities in the vicinity of Service property and for other property for which said agency normally provides fire protection; and

WHEREAS, the Service and Company have determined that the Memorandum of Understanding herein described is compatible with the public interest.

NOW, THEREFORE, pursuant to 42 U.S.C. 1856a, both parties do mutually understand and agree as follows:

Figure G.8. Sample Memorandum of Understanding Between a Park and a Fire Company

Article II
Statements of Work

The Memorandum of Understanding (MOU) herein made is subject to the following terms and conditions:

General

(1) The purpose of this MOU is to provide mutual aid and assistance between [*Name of Park*] and the [*Name of Fire Department/Company*] of [*Name of city or county and state*], should emergency medical services be needed in structural fires [*as applicable, include wildfires or hazardous materials spills*] that occur on, or threaten or endanger property under the protection of either agency.

(2) The area of Park property covered by this MOU will be that area within the [*Name of Fire Department/Company*] response area of [*Name of city or county and state*].

(3) In the execution of this MOU, employees or agents of the company are not considered employees of the park or NPS.

(4) The Service, Park and the [*Department/Company*] waive all claims against each other for compensation for any loss, damage, personal injury, or death occurring in consequence of activities pursuant to this MOU.

(5) All structural fire suppression personnel will meet, as a minimum, the requirements found in NPS-58, Structural Fire Guidelines.

(6) The Park and [*Department/Company*] agree to notify the other of available training the areas identified in No. (8) below and participate in joint training exercises when possible.

(7) Park and Company representatives will meet Quarterly (January, April, July, October) to discuss mutual aid operations and to evaluate the MOU for revisions and renewal. Any revisions of this Agreement must be in writing, receive proper approval, and be signed by the parties hereto. Renewals will be subject to regulations existing at the time of renewal and such other terms and conditions deemed necessary to protect the public interest.

(8) The provisions of this MOU are divided into the following sections: Structural Fire; [*as applicable, include other sections, such as Wildfire (Forest Fire); Emergency Medical Service/Search and Rescue; and Hazardous Materials.*]

Structural Fire

(1) As an aid to implementing this MOU, selected members of the [*Department/Company*] (including the Fire Chief and the Ambulance Chief) will, at least annually, visit the Park and, accompanied by the Park Superintendent or designated representative, survey park buildings for the purpose of developing a Building Pre-Plan. Special fire fighting procedures necessary to safeguard museum objects and archival and manuscript collections housed within the structure will be identified in the Building Pre-Plan. Current floor plans of Park buildings will be provided to the Company Fire Chief.

**Figure G.8. Sample Memorandum of Understanding Between
a Park and a Fire Company (continued)**

(2) The Company will respond to all reported structural fires in the Park (within the [Department's/Company's] response area) as promptly as possible and with due regard for the safety of all persons. Upon arrival at the scene of the reported structural fire:

(a) *Park Ranger not at the scene.* The Officer-in-Charge for the [Department/Company] will check the perimeter of the building for signs of fire. If sign of a fire is detected, he/she will assume direction of all fire fighting activities until relieved by a superior officer or until the fire is extinguished and declared out. If no sign of a fire is detected, he/she will wait for arrival of a Park Ranger.

(b) *Park Ranger at the scene.* If the ranger has already checked the structure for sign of fire and the alarm system, he/she will so advise the Officer-In-Charge of the [Department/Company]. If not, the ranger and the Officer-In-Charge will jointly check the structure for sign of fire. If sign of a fire is detected, the Officer-In-Charge for the Company will assume direction of all firefighting activities until relieved by a superior officer or until the fire is extinguished and declared out. If the structure has been identified in the Building pre-Plan as requiring special precautions necessary to safeguard museum objects and archival and manuscript collections within the structure, the ranger will so notify the Officer-In-Charge. The ranger will notify the officer-in-charge of any hazardous materials in the collection (such as cellulose nitrate film).

(3) Each party to this MOU will furnish such equipment and personnel to aid the other party with a structural fire as can be made without jeopardizing the fire protection of its own area of responsibility.

(4) All requests for Park Aid to assist with a structural fire must originate from the Company's senior fire official at the scene of the fire to the Park Superintendent or designated representative.

[As appropriate, include language on wildfire (forest fire), emergency medical service/search and rescue, and hazardous materials.]

Article III

Term of Memorandum of Understanding

The Memorandum of Understanding hereby made shall terminate one (1) year from the effective date hereof, at noon, [Name of State] time, unless prior thereto it is relinquished, abandoned, or otherwise terminated pursuant to the provisions of this MOU or of any applicable Federal law or regulation. In addition, the MOU will expire at the end of the specified term unless formally reaffirmed or rewritten if necessary. The effective date of this MOU shall be the date of its execution by the Superintendent, [Name of Park].

Unless relinquished, abandoned, or otherwise terminated pursuant to the provisions of the MOU or of any applicable Federal law or regulations, the MOU will be considered for renewal.

Figure G.8. Sample Memorandum of Understanding Between a Park and a Fire Company (continued)

Article IV
Key Officials

This Memorandum of Understanding is subject to the conditions of the Superintendent or representative, and shall comply with the regulations of the Secretary of the Interior and other applicable conditions as outlined herein.

Superintendent
[Name of Park]
[Complete Address]

The President and Fire Chief of [Name of Fire Department/Company] will direct operations according to the conditions agreed to in this MOU.

[Name of President]	[Name of Fire Chief]
[Name of Department/Company]	[Name of Department/Company]
[Complete Address]	[Complete Address]

Article V
Reports

Each party is responsible for its respective timekeeping and other required records and reports.

Article VI
Termination

This Memorandum of Understanding may be terminated upon breach of any of the conditions herein or at the discretion of either party. Termination shall be done by providing ninety (90) days written notice to the other.

Article VII
Required Compliance

All activities pursuant to this Memorandum of Understanding shall be in compliance with the requirement of Executive Order 11246, as amended; Title VI of the Civil Rights act of 1964 (78 Stat. 252: 42 U.S.C. 2000d et seq.); and with all other federal laws and regulations prohibiting discrimination on grounds of race, color, national origin, handicap, religion, or sex in employment and in providing facilities and services to the public.

No member or delegate to Congress, or resident Commissioner, shall be admitted to any share or part of this agreement, or to any benefit that may arise therefrom, but this provision shall not be construed to extend to this agreement if made with a corporation for its general benefit.

**Figure G.8. Sample Memorandum of Understanding Between
a Park and a Fire Company (continued)**

This Memorandum of Understanding is subject to the provisions of 18 U.S.C. 1913, which provide:

No part of the money appropriated by any enactment of Congress shall, in the absence of express authorization by Congress, be used directly or indirectly to pay for any personal service, advertisement, telegram, telephone, letter, printed or written matter, or other device, intended or designed to influence in any manner a Member of Congress, to favor or oppose, by vote or otherwise, any legislation or appropriation by Congress, whether before or after the introduction of any bill or resolution proposing such legislation or appropriation; but this shall not prevent officers or employees of the United States or of its departments or agencies from communicating to Members of Congress on the requests for legislation or appropriations which they deem necessary for the efficient conduct of the public business.

Whoever, being an officer or employee of the United States or of any department or agency thereof, violates or attempts to violate this section, shall be fined not more than \$500 or imprisoned not more than one year, or both; and after notice and hearing by the superior officer vested with the power of removing him, shall be removed from office or employment.

Nothing contained in this Memorandum of Understanding shall be construed as binding the Service to expend in any one fiscal year any sum in excess of appropriations made by Congress for the purposes of this Memorandum of Understanding for that fiscal year, or as involving the Service in any contract or other appropriation for the further expenditure of money in excess of such appropriations.

IN WITNESS WHEREOF, the Superintendent of [*Name of Park*], acting on behalf of the National Park Service, in the exercise of the delegated authority from the Secretary of the Department of the Interior, has caused this Memorandum of Understanding to be executed this [Date] day of [month], [year].

[*Name of Superintendent or Manager*]
[*Name of Park or Center*]

ACCEPTED THIS [Date] DAY OF [Month], [Year].

[*Name of Fire Department/Company*]

[*Name of Fire Chief*]
[*Name of Fire Department/Company*]

**Figure G.8. Sample Memorandum of Understanding Between
a Park and a Fire Company (continued)**

Appendix H: Curatorial Health and Safety

	Page
A. Laws, Regulations, and NPS Policies and Guidelines	H:1
B. Sources of Assistance	H:2
Federal agencies and cooperators for health and safety.....	H:2
Professional organizations for health and safety management	H:3
Other organizations.....	H:4
C. Sources of Health and Safety Equipment and Supplies	H:5

APPENDIX H: CURATORIAL HEALTH AND SAFETY

A. Laws, Regulations, and NPS Policies and Guidelines

The following authorities and guidelines cover curatorial health and safety in the NPS:

- The Occupational Safety and Health Act of 1970 provides the requirements on which each federal agency's safety and health program is based. See <http://www.osha-slc.gov/oshAct_data/OSHACT.html>.
- The Comprehensive Drug Abuse Prevention and Control Act of 1970 establishes the mechanisms for reducing the availability of controlled substances and the procedures for bringing a substance under control.
- The Resource Conservation and Recovery Act (RCRA) of 1986 directs the Environmental Protection Agency to develop and implement a program to protect human health and the environment from improper hazardous waste management practices. See <<http://www.epa.gov/epahome/laws.html>>.
- Executive Order 12196 (1980) directs each federal agency to provide a safe and healthful working environment for its employees. See <<http://www.nara.gov/fedreg/eos/e12196.html>>.
- 29 CFR 1910.134 provides guidance regarding the use of respirators. See <<http://www.osha.gov/comp-links.html>>.
- 29 CFR 1910.1000, Subpart Z provides tables listing toxic and hazardous substances and maximum exposure levels. See <<http://www.osha.gov/comp-links.html>>.
- 29 CFR 1910.1200 (Revised 1987) provides specific guidance on implementing the Occupational Safety and Health Administration (OSHA) Hazard Communication Standard. See <<http://www.osha.gov/comp-links.html>>.
- 29 CFR 1910.1450 (Effective 5/1/90) provides guidance relevant to occupational exposure to hazardous chemicals in laboratories. See <<http://www.osha.gov/comp-links.html>>.
- 29 CFR 1910.1047 (Revised 1985) regulates the use of the fumigant ethylene oxide. See <<http://www.osha.gov/comp-links.html>>.
- 29 CFR 1960 provides basic program direction for Federal Employee Occupational Safety and Health Programs. See <<http://www.osha.gov/comp-links.html>>.
- The *Department Manual*, Part 485, establishes the Department of the

Interior (DOI) safety and health program. See <<http://elips.doi.gov/>>.

- Director's Order #50B: Occupational Safety and Health, covers the occupational safety and health of NPS employees. The NPS Risk Management Program has been developed to establish and implement a continuously improving and measurable risk management process. See <<http://www.nps.gov/refdesk/DOrders/index.htm#manuals>>.
- Director's Order #83: Public Health, and *Reference Manual 83*, outline what the NPS will do to ensure compliance with prescribed public health policies, practices, and procedures. See <<http://www.nps.gov/refdesk/DOrders/index.htm#manuals>>.

B. Sources of Assistance

1. *Federal agencies and cooperators for health and safety*

The following federal agencies regulate aspects of the National Park Service health and safety program:

- The ***Occupational Safety and Health Administration (OSHA)***, part of the US Department of Labor, publishes and enforces safety and health regulations for most businesses and industries in the United States.

U.S. Department of Labor
Office of Public Affairs, Room N3647
200 Constitution Avenue
Washington, DC 20210

Tel: 202-693-1999
<<http://www.osha.gov>>

- The ***National Institute for Occupational Safety and Health (NIOSH)*** trains occupational health and safety professionals, conducts research on health and safety concerns, and tests and certifies respirators for workplace use.

Hubert H. Humphrey Building
200 Independence Avenue, SW, Room 715H
Washington, DC 20201

Tel: 1-800-35-NIOSH
<<http://www.cdc.gov/niosh/homepage.html>>

- The ***Environmental Protection Agency (EPA)*** administers laws to control and/or reduce pollution of air, water, and land systems and regulates use and labeling of pesticides in accordance with the Insecticide, Fungicide and Rodenticide Act of 1972.

1200 Pennsylvania Avenue, NW
Washington, DC 20460

Tel: 202-260-4048
<<http://www.epa.gov>>

- The ***U.S. Department of Transportation (DOT)*** regulates the labeling and transportation of hazardous materials.

Research and Special Programs Administration
Office of Hazardous Materials Safety
400 7th Street, SW
Washington, DC 20590

Tel: 202-366-8553
<<http://www.dot.gov>>

- The ***National Pesticide Telecommunications Network*** provides objective pesticide information to any caller.

333 Weniger Hall
Oregon State University
Corvallis, OR 97331

Tel: 800-858-7378
<<http://www.ace.orst.edu/info/nptn/>>

2. ***Professional organizations for health and safety management***

In addition to the above federal agencies and cooperators, park staff should be aware of the following professional organizations that are involved in health and safety management:

- The ***American Conference of Governmental Industrial Hygienists (ACGIH)*** develops and publishes recommended occupational exposure limits each year called Threshold Limit Values (TLVs) for hundreds of chemicals, physical agents, and biological exposure indices.

1330 Kemper Meadow Drive, Suite 600
Cincinnati, OH 45240

Tel: 513-742-2020
<<http://www.acgih.org/>>

- The ***American Industrial Hygiene Association (AIHA)*** provides information on occupational and environmental health and safety issues and controls, anticipates, and evaluates environmental factors arising in or from the workplace that may result in injury, illness, or impairment, or affect the well-being of workers and members of the community.

2700 Prosperity Avenue, Suite 250
Fairfax, VA 22031

Tel: 703-849-8888
<<http://www.aiha.org>>

- The ***National Fire Protection Association (NFPA)***, a voluntary membership organization, promotes and improves fire protection and prevention. The NFPA publication *Standard No. 704: Identification of the Fire Hazards of Materials*, rates the hazard of a variety of materials

during a fire.
Batterymarch Park
Quincy, MA 02269

Tel: 617-770-3000
<<http://www.nfpa.org>>

- The *National Safety Council* educates and influences people to adopt safety and health policies, practices, and procedures to prevent losses caused by accidents and hazardous occupational or environmental exposures.

444 North Michigan Avenue
Chicago, IL 60611

Tel: 312-527-4800
<<http://www.nsc.org/>>

- The *American National Standards Institute (ANSI)*, a voluntary membership organization, develops consensus standards nationally for a wide variety of health and safety devices and procedures.

1420 Broadway
New York, NY 10018

Tel: 212-354-3300
<<http://www.ansi.org>>

3. *Other organizations*

In addition to the Park Safety Officer, the Regional Safety Officer, the regional/SO curator, the WASO Risk Management Division, and the Museum Management Program, National Center for Cultural Resources, the following organizations have extensive experience in dealing with occupational health and safety issues/problems in museum environments:

- The *American Institute for Conservation (AIC)* Health and Safety Committee has produced information directly related to museum and conservation laboratory safety.

1717 K Street, NW, Suite 200
Washington, DC 20006

Tel: 202-452-9545
<<http://aic.stanford.edu/health/>>

- *Arts, Crafts and Theater Safety (ACTS)* is a not-for-profit corporation dedicated to providing health and safety services to the arts.

Ms. Monona Rossol, President
181 Thompson Street, #23
New York, NY 10012

Tel: 212-777-0062
<<http://www.caseweb.com/ACTS>>

C. Sources of Health and Safety Equipment and Supplies

There are several sources for obtaining desk fans, fume hoods, portable fume hoods and fume scrubbers, laboratory protective clothing and gloves, respirators, chemical storage cabinets, health and safety publications, hazard warning labels, signs and charts, and other supplies. NPS parks and centers should contact the Museum Management Program for current sources of health and safety equipment and supplies. *Tools of the Trade* is periodically updated with new information on health and safety equipment and supplies.

Appendix I: Curatorial Care of Archeological Objects

	<u>Page</u>
A. Overview	I:1
What is an archeological object?.....	I:1
What does this appendix cover?	I:2
What makes archeological objects different from other materials commonly found in museum collections?	I:2
How can I minimize deterioration of archeological objects?	I:3
B. Handling and Cleaning of Archeological Objects	I:3
How should I handle the objects?	I:3
How should I clean the artifacts in museum collections?	I:4
C. Storage Conditions for Archeological Objects	I:4
How should I organize archeological collections in storage for best preservation?	I:4
What are the environmental requirements?.....	I:5
What are the storage requirements for each of the three levels of climate sensitivity?	I:6
D. Storage Techniques for Archeological Collections	I:7
What type of storage container should I use to store archeological objects?.....	I:7
Why is silica gel often used in archeological storage?	I:8
How should I cushion my objects?.....	I:8
How should I organize the box contents?	I:8
How do I keep track of what's in the box?	I:9
How do I protect and store larger archeological objects?	I:9
How should I store very weak and fragile objects?.....	I:11
How and when should I design special containers?	I:13
How should I store items subject to the Native American Graves Protection and Repatriation Act of 1990 (NAGPRA)?	I:13
E. Selected Bibliography	I:19
List of Figures	
Figure I.1. Deterioration of Archeological Objects through Time	I:2
Figure I.2. Vertical Stacking of Small Objects within Standard Containers	I:7
Figure I.3. Organization and Layering of Objects within a Storage Box	I:9
Figure I.4. A Support Tray for Fragile Material	I:10
Figure I.5. Customized Support Blocks for a Fragile Glass Bottle to be Fitted in a Museum Specimen Tray	I:10
Figure I.6. Cavity Packing Technique for Small Objects.....	I:11
Figure I.7. Construction of a Cradle Mount for Objects with Round Bases	I:12
Figure I.8. Construction of a Portfolio Mount for Archeological Textile Fragments	I:14
Figure I.9. Recommended Storage Materials	I:15

APPENDIX I: CURATORIAL CARE OF ARCHEOLOGICAL OBJECTS

A. Overview

1. *What is an archeological object?*

Archeological objects are the result or product of an activity in the past that has been recovered from an archeological site. Archeological objects may have originated in the ancient past or quite recently. Depending upon the soil and climate of the site, a wide variety of materials may be excavated.

- ***Inorganic*** artifacts include:
 - metal
 - ceramics
 - glass
 - stone
- ***Organic*** artifacts include:
 - leather
 - basketry
 - textiles
 - modern plastics and other synthetics
 - bone
 - teeth

Archeological collections may also contain non-artifactual samples, such as botanical material, soils, pollen, phytoliths, oxylate crystals, snails, insect remains, and parasites.

While some individual archeological objects are found in NPS collections, the majority have been recovered as part of systematic archeological excavation. Preservation and care of individual objects must also consider the impact on the collection as a whole.

An important part of archeological collections are the associated archival records (for example, field notes, photographs, maps, digital documentation). For information on managing and preserving these archival records see *Museum Handbook*, Part II (*MH-II*), Appendix D: Museum Archives and Manuscript Collections and *Museum Handbook*, Part I (*MH-I*), Appendix J: Care of Paper Objects, Appendix M: Management of Cellulose Nitrate and Cellulose Ester Film, and Appendix R: Curatorial Care of Photographic Collections.

2. *What does this appendix cover?*

This appendix provides guidance only on the care of objects excavated from the ground. For guidance on collections from marine excavations, consult an archeological objects conservator with experience in the treatment of waterlogged materials. See Chapter 3: Preservation: Getting Started, Chapter 8: Introduction to Museum Object Conservation Treatment, and Conserve O Grams 6/1-6/6 for more information.

This appendix does not cover field treatment of objects when first excavated. Good sources of information on this topic include Sease (1987) and Watkinson and Neal (1998) listed in the references.

3. *What makes archeological objects different from other materials commonly found in museum collections?*

What makes archeological objects different is that at some point they were lost or abandoned and buried underground or in water.

The condition of these objects depends entirely on their reaction with the environmental conditions to which they have been exposed through time. Underground the object reaches a kind of equilibrium with the surrounding soil. Then, when the object is excavated, it must adjust to a new and radically different environment. Reactions can involve both physical and chemical changes. Regardless of the condition of the object before excavation, the moment it becomes exposed it is vulnerable to rapid deterioration. Figure I.1 illustrates the deterioration rate of archeological objects through time.

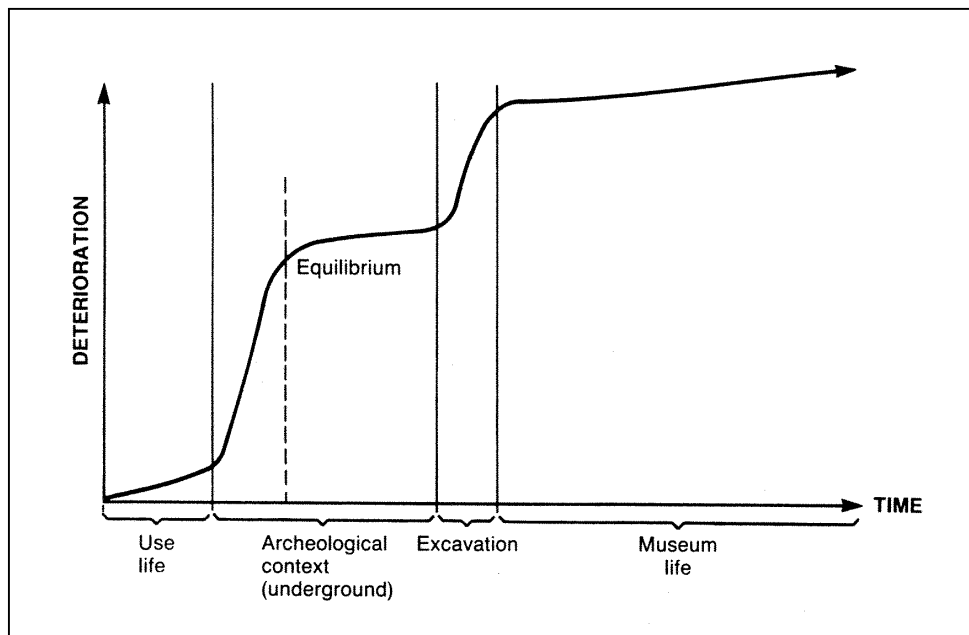

Figure I.1. Deterioration of Archeological Objects through Time

4. *How can I minimize deterioration of archeological objects?*

Preservation of archeological collections is a collaboration between archeologists, curatorial staff and conservators. Each person brings a different perspective and expertise to the problem. It is important to understand the concerns and needs of these other professionals when making decisions about how to care for archeological objects.

Preservation must begin in the field. Curatorial staff should work with archeologists depositing collections to make sure that preservation concerns are addressed during archeological procedures at the site and in the processing laboratory. Work with conservators both in the field and at the repository to ensure preservation choices are based on current research. Follow through with proper curatorial care in museum collections storage.

Refer to Director's Order #28 and Chapter 6: Management of Archeological Resources of the *Cultural Resources Management Guideline*, for guidance on the responsibilities of the archeologist before selecting a repository and depositing collections. See Director's Order #24, NPS Museum Collections Management, for park management's responsibility to ensure appropriate care and management of archeological collections.

C. Handling and Cleaning of Archeological Objects

1. *How should I handle the objects?*

Because the research value of archeological material may be lessened or destroyed by unnecessary handling and inappropriate treatment, preservation of these materials should be based on preventive care. Careful handling, packaging, and storing of archeological objects are crucial for the survival of the material as an artifact. Mishandling and storage will encourage deterioration and can reduce the material to nothing more than powder.

Archeological objects can have a deceptive appearance of strength when first uncovered. All excavated materials have undergone some form of alteration during the equilibration process underground and during the recovery process. This alteration has physically weakened the object. While underground, objects are supported by the surrounding soil, and when excavated, they may be unable to support their own weight. For this reason, archeologists and conservators often use specialized lifting techniques to excavate fragile and potentially fragile objects. During and after excavation, continue to support these objects on a tray or pallet or in a container that distributes weight properly.

An archeological object must always be fully supported. Use both hands, a tray, or a supporting container to lift and carry an object, whether it is large or small. Always assume that an excavated object is weak.

Review the guidelines for handling museum objects in Chapter 6: Handling, Packing, and Shipping Museum Objects.

2. *How should I clean the artifacts in museum collections?*

Cleaning of archeological material should be kept to a minimum. The cleaning process may destroy important archeological evidence such as surface decorations and composite or associated materials that often exist only as impressions on the surface of the object or in the surrounding soil. Original surfaces of metal objects may lie within layers of corrosion. Evidence of use (for example, food residue in containers, pigment traces on stone palettes, or blood traces on stone projectile points) may be removed by unnecessary cleaning.

Cleaning may also interfere with scientific analysis. For example, the use of acid to remove deposits on ceramics may also remove acid-soluble compounds in the ceramic paste and as a result, invalidate compositional analysis used to determine the prehistoric source of clay. See *Conserve O Gram* 6/6, "Long-term Effects of Acid-Cleaning Archeological Ceramics." Water can also remove amino acid traces used to date bone. Washing may also hasten deterioration of salt-contaminated material and can be disastrous to metal objects if they are not carefully and completely dried afterward.

Avoid any treatment that alters the chemical or physical integrity of the artifact. Don't risk losing valuable information or inflicting irreversible damage.

Once an object has reached the repository and is in curatorial care, remove only loose dust and dirt by dry brushing or vacuuming. ***Don't*** wash the object and ***don't*** apply pressure. The surface of an archeological object is often fractured or friable and may be easily dislodged by rubbing. Carefully assess an object's surface ***before*** you start to clean it. If additional cleaning, stabilization, or repair is necessary, consult an experienced conservator.

D. Storage Conditions for Archeological Objects

1. *How should I organize archeological collections in storage for best preservation?*

Archeological collections are often large and contain a variety of materials with different environmental storage requirements and with different research values. Physical organization of the collections by research values, such as source or cultural affiliation, will not necessarily meet preservation needs. It is better to organize the materials by environmental requirements and maintain the research integrity of the collection through good museum records.

Ideally, all archeological objects should be stored in climate-controlled areas, but this often is not practical. Most archeological collections are large and not all storage facilities have enough climate-controlled storage space to house entire collections. In such cases, it is possible to maximize preservation while minimizing utility costs by implementing a storage strategy based on the environmental requirements of various archeological materials.

2. *What are the environmental requirements?* See the chart below for a system to organize archeological material by environmental sensitivity.

Organization of Archeological Material	
<i>Level I: Negligibly climate-sensitive materials</i>	
<p>Materials:</p> <ul style="list-style-type: none"> • stable stone and fired ceramics • stable inorganic architectural materials (plaster, mud, daub, brick, and stone) • dry pollen, flotation, and unprocessed soil samples • faunal remains 	<p>Required Climate: Gradual daily and seasonal fluctuations of temperature and relative humidity can be tolerated.</p> <ul style="list-style-type: none"> • Relative Humidity: Above 30% and below 65%. Mold may become a problem above 65%. • Temperature: Freezing to 100°F. Moderate and cool temperatures are preferred. High temperatures increase deterioration of all materials.
<i>Level II: Climate-sensitive materials</i>	
<p>Materials:</p> <ul style="list-style-type: none"> • stable metal • stable glass • worked bone, antler, and shell • botanical specimens • textiles • wood • skin, leather, and fur • feathers and horn • natural gums, resins, and lacquer • human remains 	<p>Required Climate:</p> <ul style="list-style-type: none"> • Relative Humidity: Determine a stable point based on the object's environmental history and current regional climate. If the materials will be stored near the collection site, you may follow these guidelines. 30-40%--semi-arid areas and deserts 40-50%--central and eastern plains and woodlands 45-55%--seacoast and lakeshore <p>Keep conditions as stable as possible. Many organic materials are more sensitive to fluctuations of relative humidity than to any one unchanging level in the moderate range. Do not allow daily fluctuations of more than 3%. From summer to winter, keep the change to no more than a slow 10% drift.</p> <ul style="list-style-type: none"> • Temperature: Above 50° F and below 75° F. You may adjust the temperature slightly to control the relative humidity, but do not exceed changes of 5° daily.
<i>Level III: Significantly climate-sensitive materials</i>	
<p>Materials:</p> <ul style="list-style-type: none"> • unstable (salt-contaminated) ceramics, stone, and bone • unstable glass (glass that appears damp or "weeping") • unstable metal, particularly iron • mummified human and animal remains • composite objects (objects made of several different materials) 	<p>Required Climate:</p> <ul style="list-style-type: none"> • Relative Humidity: Keep the RH within the restricted range determined by the object's composition and condition. Follow these guidelines. <ul style="list-style-type: none"> – metal—under 30%. Unstable iron is best stored below 15%. – unstable glass—30% to 40% – naturally mummified animal remains—15% to 20% – unstable ceramics, stone and bone (salt contaminated)—below 50% (<i>Note:</i> Keep the RH as steady as possible to avoid damage by the hydration cycling of soluble salts.) • Temperature: Choose a point between 60° and 72° and keep the temperature steady. Allow it to fluctuate only enough to keep the RH in check.

3. *What are the storage requirements for each of the three levels of climate sensitivity?*

Each level of climate sensitivity requires a different type of storage.

- **Level I:** General storage for Level I materials should meet the *minimum* overall standards for all NPS storage spaces as outlined in Chapter 7: Museum Collections Storage.

- Store materials that do not need special attention in boxes on open shelves.
- Store loose material, including the following, in bags within boxes:
 - bulk botanical specimens
 - unprocessed soil samples
 - dry pollen and flotation samples
 - slag
 - unworked bone
 - lithic cores and debitage
 - ceramic sherds

Make sure the bags are strong and will not tear or puncture. Bags made of Tyvek®, a strong spun polyethylene plastic that allows water vapor to escape, are a good choice. Canvas bags and resealable polyethylene bags can also be used.

- **Level II:** Climate-controlled storage for Level II materials should comply with the *optimum* standards for NPS storage areas as outlined in Chapter 7.

If your park has no currently available area where the environment can be controlled, consider putting up a prefabricated, climate-controlled structure. See *Conserve O Gram 4/7*, “Museum Collection Storage Space: Is an Insulated Modular Structure Right for your Collection?” Consult your regional or support office curator, conservators specializing in environmental or preventive conservation, or the Museum Management Program for guidance in developing an acceptable storage area.

- **Level III:** Microclimate storage for some Category III materials can be created within the climate-controlled storage area used for Category II materials.
 - Place objects requiring an extremely stable environment within a closed well-gasketed museum cabinet that will shield them from even slight fluctuations in relative humidity.
 - Place metals and unstable glass, which require a relative humidity quite different from other objects in storage, in tightly sealed boxes with moisture-sensitive materials called *sorbents*. Sorbents, such as *silica gel*, buffer the interior of the container against changes in the relative humidity of the enclosed objects.

E. Storage Techniques for Archeological Collections

1. *What type of storage container should I use to store archeological objects?*

There are many different types of standard boxes and bags that are appropriate for general storage. **Note: These are not for microclimate storage.** See Chapter 4 for information on microclimate storage.

- Use acid-free boxes with lids rather than self-closing boxes with flaps that will wear out over time.
- Store small objects like lithic points and nails in boxes manufactured for the storage of archival and photographic collections.
- Use small resealable polyethylene bags for individual specimens and stack them vertically within each section of the box. You can staple them to acid-free index cards to make them easier to stack. If the objects are not numbered, include an acid-free tag with an identification number inside each bag and also be sure to write the number on the outside of the bag or on the card.

See Figure I.2. Note the easy visual access and consistent packaging technique illustrated. Never wrap objects in padding material. Wrapping and unwrapping requires excessive handling.

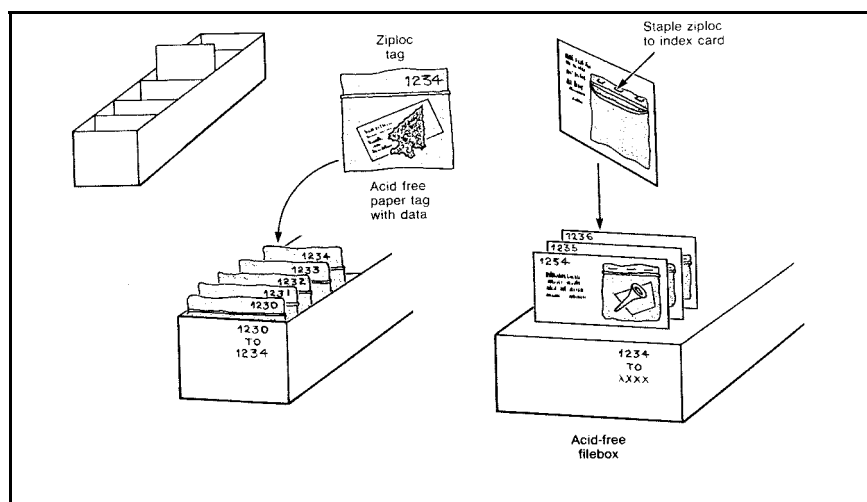

Figure I.2. Vertical Stacking of Small Objects Within Standard Containers

2. *Why is silica gel often used in archeological storage?*

Archeological objects are often unstable and very sensitive to changes in relative humidity. Silica gel can moderate fluctuations in relative humidity within a closed container.

Silica gel is inert, amorphous silicon dioxide in a porous granular form that is able to adsorb moisture from the air. It can adsorb 30-40% of its dry weight and responds more quickly than other sorbents to variations in relative humidity. The gel rapidly senses, corrects, and stabilizes fluctuations in relative humidity by humidifying or dehumidifying the air around it to maintain its own preferred environment. See Chapter 4: Museum Collections Environment, for information on use of silica gel in microclimates.

3. *How should I cushion my objects?*

Use padding material to prevent the contents of a container from shifting when it is moved. Be careful not to overstuff the box with crumpled tissue or other padding material that could exert damaging pressure on fragile objects. Use either of these cushioning techniques:

- Make smooth pillows to place against the surface of the object by folding wadded acid-free *unbuffered* tissue paper within loose rolls of tissue. Wrapping the crumpled tissue will keep it from expanding and exerting pressure.
- Fill resealable sandwich-sized polyethylene bags with cotton.

Don't use cotton or polyester wool alone. Cotton is an excellent sorbent and may hold moisture directly against the object. Fibers from these materials may snag and damage delicate artifacts.

4. *How should I organize the box contents?*

Organize your artifacts so that each object can be easily retrieved without disturbing the rest. One technique is to layer your items. If they are small and lightweight, they can be organized into three or four layers separated by specimen trays within your storage box. Specimen trays make lifting safer. Cushion each layer with a sheet of stable polyethylene foam shelf liner. See Figure I.3. Museum supply companies manufacture acid-free boxes with fitted trays equipped with adjustable interior compartments. These are ideal for the storage of archeological material.

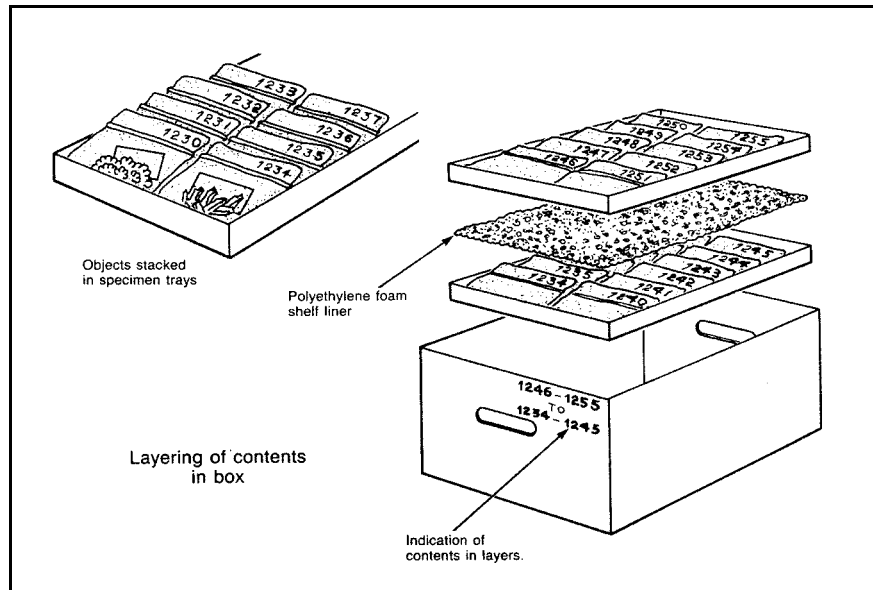

Figure I.3. Organization and Layering of Objects within a Storage Box

5. *How do I keep track of what's in the box?*

Make an inventory:

- First, make sure that the identification numbers you have written on each bag show clearly.
- Next, label the outside of the box with the numbers by layer.
- Prepare a more detailed list of the contents and place it in the box on top of the contents.

6. *How do I protect and store larger archeological objects?*

If the objects are too large for standard specimen trays, you can make custom trays from padded, acid-free board fitted with cotton twill-tape handles. See Figure I.4 for an illustration. There are many acid-free boards, including matboard, cardboard, foamboard, and honeycomb board, that can be used to make support trays. Make sure you select a board heavy enough not to bend under the weight of the object. Tie the object to the tray with cotton twill tape to keep it from sliding.

Use rigid polyethylene foam to make tray supports and trays with cavities for fragile three-dimensional objects. You can easily cut large blocks of foam with an electric carving knife and thin sheets with a sharp X-acto knife. Figure I.5 illustrates the use of rigid polyethylene foam blocks to support a fragile bottle. Figure I.6 shows the cavity-packing technique to restrict the movement of smaller, rounded items. Cavity-packing is an excellent way to store objects that are moved periodically for research. Make sure that the fit of the object in the cavity is not too tight and that the object may be safely removed from the tray. The cut edge of the rigid foam block can be abrasive so use thin, soft, polyethylene foam (like Volara®) for objects with fragile surfaces. If necessary, carve a finger grip on each side of the object to make grasping easier.

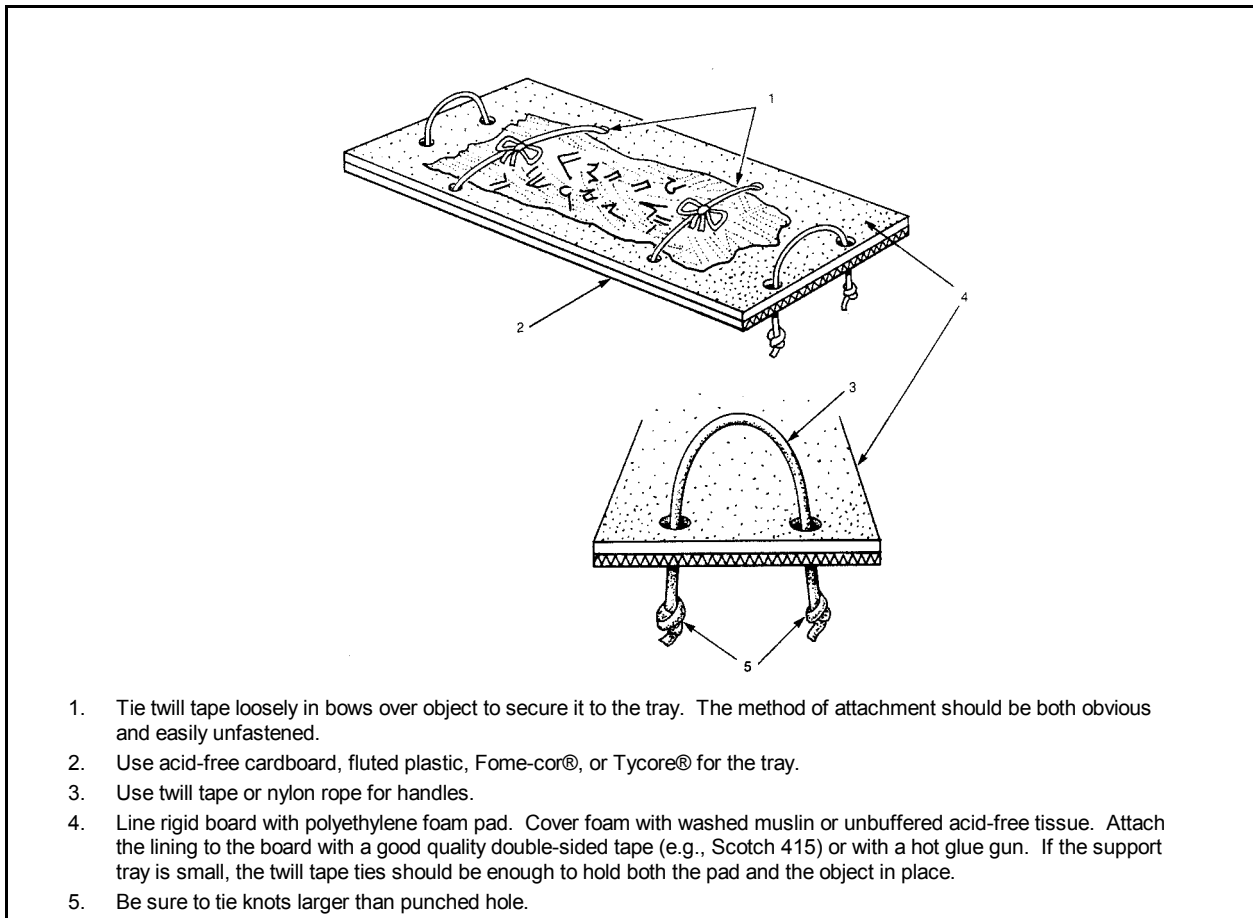

Figure I.4. A Support Tray for Fragile Material

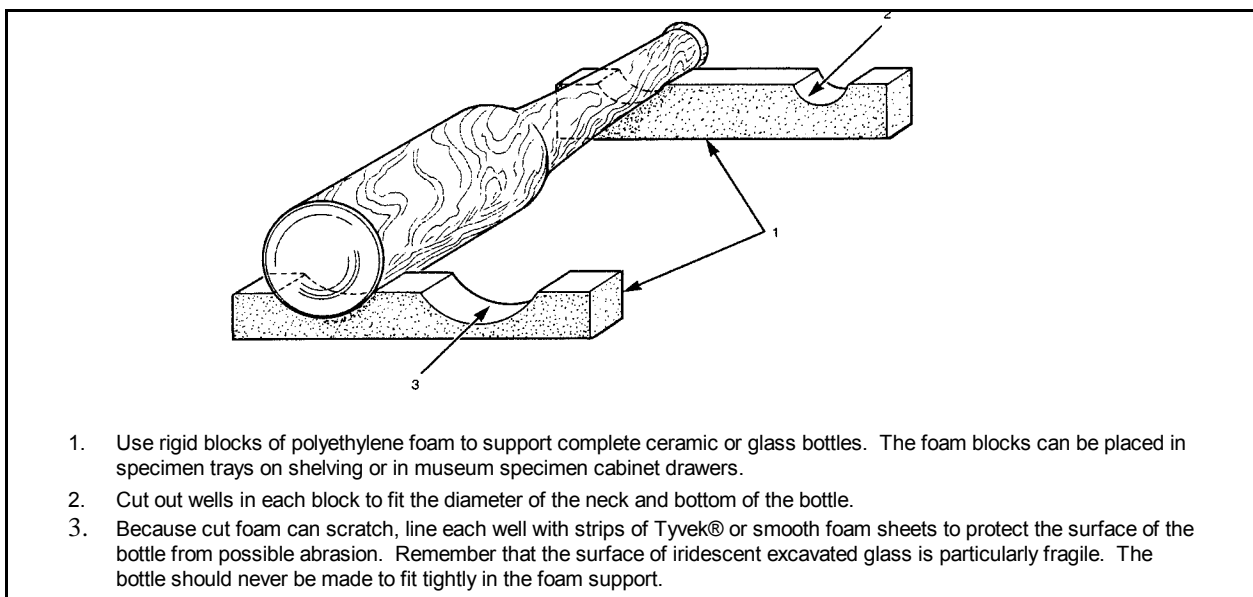

Figure I.5. Customized Support Blocks for a Fragile Glass Bottle to be Fitted in a Museum Specimen Tray

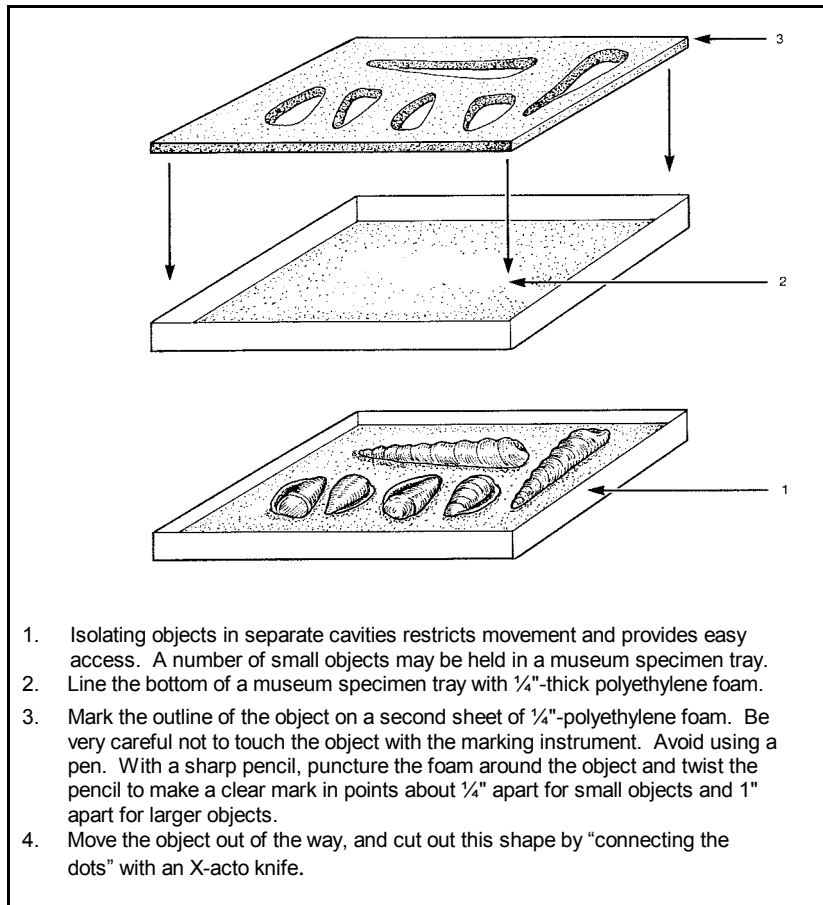

Figure I.6. Cavity Packing Technique for Small Objects

7. *How should I store very weak and fragile objects?*

Archeological objects that are weak from deterioration may require specialized supports to maintain their structural integrity. Before designing a special mount, evaluate the object's strong and weak structural points. Determine:

- what the object is
- how it was used or worn
- how it was made

For example, cone-shaped baskets, worn like backpacks, were used to carry heavy objects. Load stresses were distributed down the sides of the basket and concentrated in the bottom. Though the rim is the weakest part of these baskets, they are frequently, but incorrectly, stored upside down like traffic cones.

A good storage mount takes into account the *form* and *function* of the object and eliminates stress on the weakest parts. A cradle mount like the one illustrated in Figure I.7 will evenly distribute the weight of an object with an unstable base while keeping it upright as originally used.

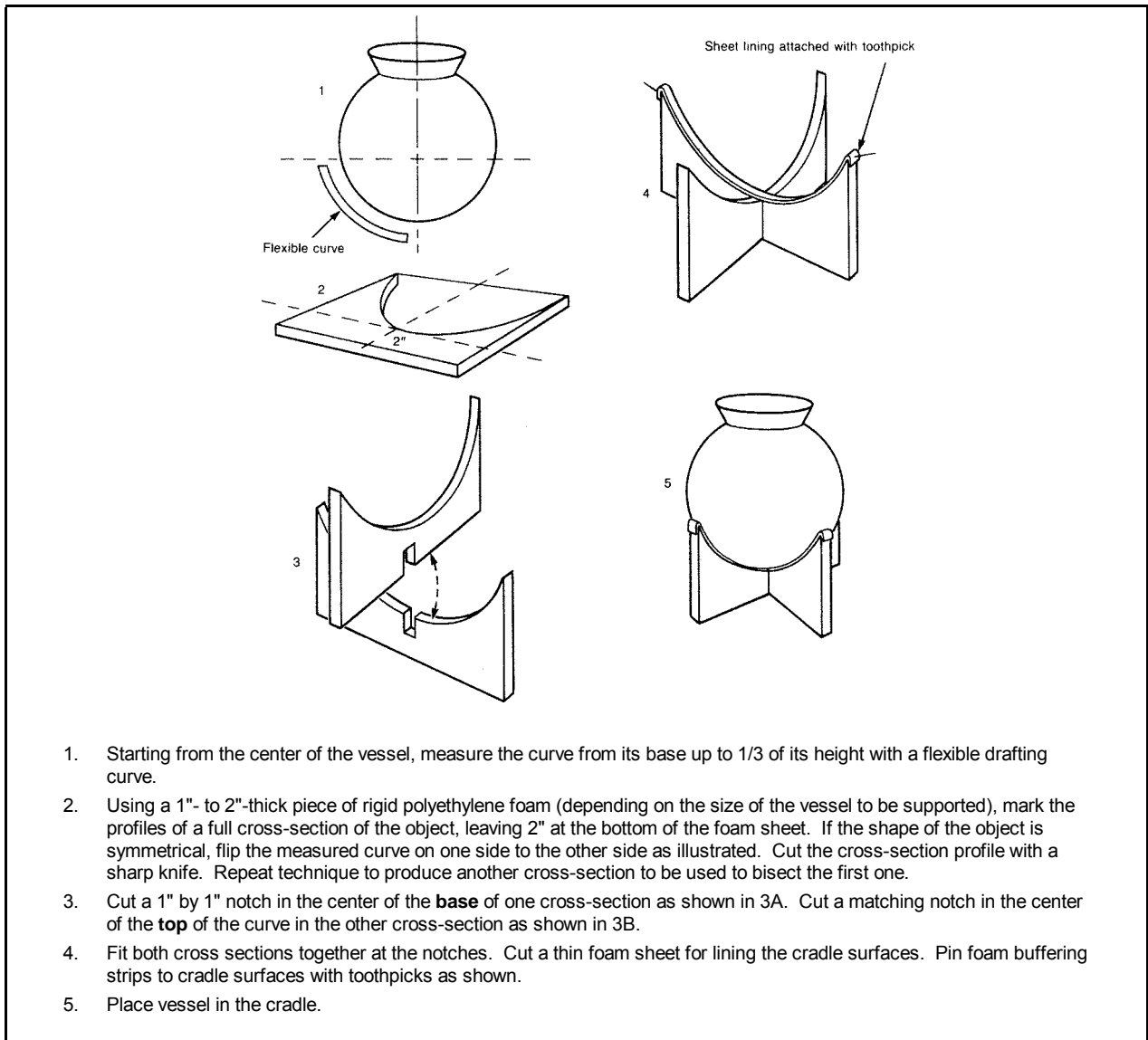

Figure I.7. Construction of a Cradle Mount for Objects with Round Bases

8. *How and when should I design special containers?*

When making a special box or storage container for an archeological object, keep these things in mind.

- Protect the object from dust and light.
- Provide it with good support.
- Allow researchers maximum visual access.
- Discourage any handling of the object.

In the case of a textile fragment, for example, a researcher will want to examine both sides. The container must permit close examination of the contents, but minimize the need to actually handle the object. A portfolio mount, illustrated in Figure I.8, is a good solution to this problem. This technique can also be used to store other flat objects like basketry fragments, thick cordage, and other fragile materials. Adjust the thickness of the interior mat to accommodate the dimensions of the object, avoiding any unsafe pressure or crushing of brittle elements.

Boxes for other types of artifacts should have a drop front so that the tray supporting the item can be slid out onto a stable surface. An accident is more likely to happen if the object must be lifted up and out through the top.

You may need to provide special containers and mounts that will protect fragile, unstable, and top-heavy objects during an earthquake.

There is much published information containing instructions for building specialized storage mounts. Two very good references are *Storage of Natural History Collections: Ideas and Practical Solutions* (Rose and de Torres, 1995) and *Working with Polyethylene Foam and Fluted Plastic Sheet* (Schlichting, 1994).

To help you select stable materials for constructing containers and mounts for storage see *Materials for Exhibit, Storage, and Transportation and Packing* (Tétreault and Williams, 1992) and “Guidelines for Selecting Materials for Exhibit, Storage, and Transportation” by Jean Tétreault, available on the Web at <http://www.cci-iic.gc.ca/frameset_e.shtml> under Conservation Information.

9. *How should I store items subject to the Native American Graves Protection and Repatriation Act of 1990 (NAGPRA)?*

Your park’s archeology collection may contain NAGPRA-related items such as human remains, associated funerary objects, unassociated funerary objects, sacred objects, and objects of cultural patrimony. These collections should be housed and handled with great sensitivity. You may need to store NAGPRA items separately from other collections and limit access to them.

Consult with the lineal descendants, culturally affiliated Indian tribes, Native Alaskan villages or corporations, or Native Hawaiian organizations to ascertain their preferences related to storage techniques and materials. You may need to use alternative storage methods and materials in response to these consultations. See Chapter 7: Museum Collections Storage, for additional information concerning consultation and storage of NAGPRA collections.

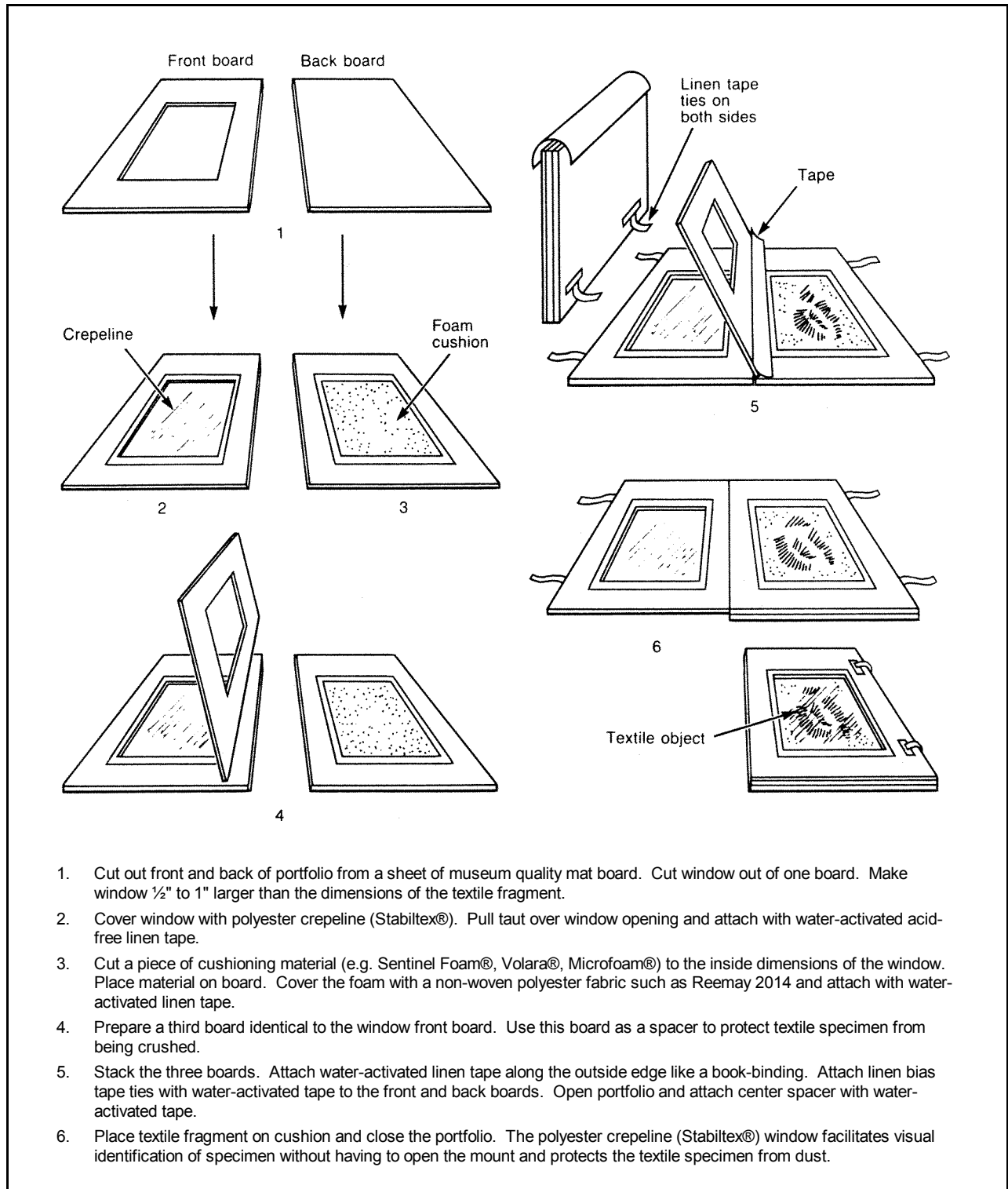

Figure I.8. Construction of a Portfolio Mount for Archeological Textile Fragments

Recommended Storage Materials

Bags

Use:	Don't Use:
<ul style="list-style-type: none"> • Resealable polyethylene bags (Ziploc®, Baggies®, Whirl-pak®) • Spun polyethylene bags (Tyvek®) • Bags made from heat-sealable clear plastic laminate film 	<ul style="list-style-type: none"> • Kraft lunch bags • Waxed paper • Envelopes <p>None allow visual inspection and all are made from unstable materials. Waxed paper may leave a coating on the object.</p>

Padding

Use:	Don't Use:
<ul style="list-style-type: none"> • Acid free tissue • Cotton or polyester batting in plastic or muslin bags • Polyester felt • Bubble-pak or air-cap 	<ul style="list-style-type: none"> • Loose cotton <p>Brittle materials may snag on the loose fibers. Cotton will almost certainly leave lint on the objects.</p> <ul style="list-style-type: none"> • Paper towels or facial or toilet tissue <p>Papers are not durable and contain impurities.</p> <ul style="list-style-type: none"> • Newspaper <p>Newsprint smears easily and may leave ink on objects. Newspaper is also very acidic.</p> <ul style="list-style-type: none"> • Excelsior <p>Material is very acidic.</p> <ul style="list-style-type: none"> • Vermiculite <p>Substance generates dust that not only is difficult to remove, but also hazardous to museum workers</p>

Figure I.9. Recommended Storage Materials

Plastic Foams	
Use:	Don't Use:
<ul style="list-style-type: none"> • White polyethylene closed-cell foam (Polyfoam) • Crosslinked polyethylene foam (Plastazote®, Volara®) • Ethylene/vinyl acetate copolymers (Evazote®, Volara®) • Extruded plank polystyrene (Styrofoam) • Polypropylene closed-cell foam (Microfoam) 	<ul style="list-style-type: none"> • Blue polyethylene foam (fire retardant) Fire retardant additives can migrate to materials. • Pink polyethylene foam (antistatic) Conductor in foam absorbs water from the air and can become soapy. • Chlorinated or nitrated plastic (for example, PVC–polyvinyl chloride) Plastic outgases hydrogen chloride, which can become hydrochloric acid. • Polyurethane This is unstable and may offgas harmful products.

Clear Plastic Sheets	
Use:	Don't Use:
<ul style="list-style-type: none"> • Polyethylene terephthalate clear polyester (Mylar®) • Clear polyester and fluorocarbon laminate (Film-O-Wrap®) • Clear polyester/polyolefin laminate (Scotchpak®) 	<ul style="list-style-type: none"> • Polyvinylidene chloride (for example, Saranwrap®) PVC is unstable, chlorinated plastic. • Cellophane Sulphuric acid used in manufacturing process generates acidic by-products.

Figure I.9 Recommended Storage Materials (continued)

Boards	
Use	Don't Use
<ul style="list-style-type: none"> • Acid-free mat board • Acid-free corrugated board • Acid-free Fome-Cor® (International Paper Co.); extruded polystyrene with polystyrene skin • Honeycomb boards <ul style="list-style-type: none"> – acid-free rigid paperboard (Tycore®) – aluminum-board (Hexcel Honeycomb®) • Corrugated polypropylene boards (Cor-X®, Coroplast®) • Double-walled polycarbonate (Lexan®) 	<ul style="list-style-type: none"> • Regular cardboard or matboard <p style="margin-left: 20px;">Non-archival cardboard and matboard are acidic.</p> <ul style="list-style-type: none"> • Urea formaldehyde impregnated paper laminated panel board (Gatorfoam®)

Tape/Ties	
Use	Don't Use
<ul style="list-style-type: none"> • Water-activated paper or linen tape • Cotton or polyester twill tape 	<ul style="list-style-type: none"> • Pressure sensitive tapes, including: <ul style="list-style-type: none"> – cellophane – masking – strapping – duct – electrical <p style="margin-left: 20px;">The adhesive degrades and the carrier peels off leaving residues and stains.</p> <ul style="list-style-type: none"> • Rubber bands <p style="margin-left: 20px;">Rubber degrades and sticks to the surface.</p>

Figure I.9. Recommended Storage Materials (continued)

Fabric	
Use	Don't Use
<ul style="list-style-type: none"> • Polyester Stabiltex • Reemay 2014 • Washed muslin 	<ul style="list-style-type: none"> • Wool fabric • Unwashed muslin <p style="margin-left: 20px;">Sizing may attract pests.</p>

Figure I.9. Recommended Storage Materials (continued)

F. Selected Bibliography

- Adamson, Helen. "Storage of Archaeological Material: The Problems." *Museum Archaeologist* 3 (1979): 3-9.
- Christenson, Andrew L. "Cultural Resource Management; The Role of Museums in Cultural Resource Management." *American Antiquity* 44, no. 1 (1979): 161-163.
- Dowman, Elizabeth A. *Conservation in Field Archaeology*. London: Methuen and Co., 1970.
- Ford, Richard I. "A Three-Part System for Storage of Archeological Collections." *Curator* 23, no. 1 (1980): 55-62.
- Hodges, H. W. M. "Problems and Ethics of the Restoration of Pottery." Conservation in Archaeology and the Applied Arts, *Contributions to the Stockholm Congress, IIC, June 2-6, 1975*: 37-38.
- Johnson, Jessica S. "Soluble Salts and Deterioration of Archeological Materials." *Conserve O Gram* 6/5. Washington, D.C.: National Park Service, 1998.
- . "Long-Term Effects of Acid-Cleaning Archeological Ceramics." *Conserve O Gram* 6/6. Washington, D.C.: National Park Service, 1999.
- Keene, S., ed. "Conservation Archaeology and Museums." *Occasional Papers* No. 10. London: United Kingdom Institute for Conservation, 1980.
- Lafontaine, R.H. "Silica Gel." *Technical Bulletin* 10. Ottawa, Ontario: Canadian Conservation Institute, 1984.
- Leigh, David. "The Selection, Conservation and Storage of Archaeological Finds." *Museums Journal* 82, no. 2 (1982): 115-116.
- Majewski, Lawrence. "On Conservation: Archaeological Sites." *Museum News* 51, no. 3 (1972): 11-12.
- Moyer, Curt. Archaeological Conservation Forum: "This is not a Fixit Shop!" *Society for Historical Archaeology Newsletter* 19, no. 2 (1986): 33-36.
- Pye, Elizabeth. "Conservation and Storage: Archaeological Material." In *Manual of Curatorship*, 203-238. London: Butterworths, 1986.
- Raphael, Toby. *Exhibit Conservation Guidelines*. CD-ROM. Harpers Ferry, W.V.: Division of Conservation, Harpers Ferry Center, NPS, 1999.
- . "Using Silica Gel in Microenvironments." *Conserve O Gram* 1/8. Washington, D.C.: National Park Service, 1999.
- Riss, Dan. "First Aid for Wet-Site Objects." *Conserve O Gram* 6/1. Washington, D.C.: National Park Service, 1993.
- . "Desalinization: Passive Alkaline Soak." *Conserve O Gram* 6/2. Washington, D.C.: National Park Service, 1993.
- . "Testing for Chlorides with Silver Nitrate." *Conserve O Gram* 6/3. Washington, D.C.: National Park Service, 1993.
- . "Making Percent Solutions of Chemicals." *Conserve O Gram* 6/4. Washington, D.C.: National Park Service, 1993.

Rose, C.L., and A.R. de Torres, eds. *Storage of Natural History Collections: Ideas and Practical Solutions*. Iowa City, Iowa: Society for the Preservation of Natural History Collections, 1995.

Schlichting, Carl. "Working with Polyethylene Foam and Fluted Plastic Sheet." *Technical Bulletin* 14. Ottawa, Ontario: Canadian Conservation Institute, 1994.

Sease, Catherine. A Conservation Manual for the Field Archeologist. *Archeological Research Tools*, Vol. 4, University of California, Los Angeles: Institute of Archeology, 1987.

Singley, Katherine R. "Caring for Artifacts After Excavation—Some Advice for Archaeologists." *Historical Archaeology* 15, no. 1 (1981): 36-48.

Stanley Price, Nicholas, ed. *Conservation on Archaeological Excavations*. Rome: International Center for the Study of Preservation and Restoration of Cultural Property (ICCROM), 1984.

Tétreault, Jean. "Guidelines for Selecting Materials for Exhibit, Storage, and Transportation." *Conservation Information*. <<http://www.cci-icc.gc.ca>> Canadian Conservation Institute, 1993.

Tétreault, Jean, and R. Scott Williams. "Materials for Exhibit, Storage and Packing." In: *A Systematic Approach to the Conservation (Care) of Museum Collections*. Edited by Stefan Michalski. Ottawa, Ontario: Canadian Conservation Institute, 1992.

United Kingdom Institute for Conservation

"Excavated Artifacts for Publication." *Archaeological Excavations. Conservation Guidelines* No. 1, 1983.

"Packaging and Storage of Freshly Excavated Artifacts from Archaeological Sites." *Conservation Guidelines* No. 2, 1983.

"Environmental Standards for the Permanent Storage of Excavated Material from Archaeological Sites." *Conservation Guidelines* No. 3, 1984.

Watkinson, David E. and Virginia Neal. *First Aid for Finds*. 3d ed. London: UKIC Archaeology Section/RESCUE, 1998.

Appendix J: Curatorial Care of Paper Objects

Page

A. Overview	J:1
What information will I find in this appendix?	J:1
Why is it important to practice preventive conservation with paper objects?	J:2
How do I learn about preventive conservation?	J:2
Where can I find the latest information on care of these types of objects?.....	J:2
What should I know about the history of papermaking?	J:2
What is the difference between paper and a paper object?.....	J:3
B. The Nature of Paper Objects	J:3
What is the structure of paper?	J:3
What is cellulose?.....	J:4
What fibers have been used historically to make paper?.....	J:4
What causes groundwood paper to be unstable?	J:4
How is paper quality judged?	J:4
How does the nature of some paper objects affect their preservation?.....	J:5
C. Agents of Deterioration	J:5
What causes paper to deteriorate?	J:5
How does temperature affect paper objects?.....	J:6
How does relative humidity affect paper objects?.....	J:6
What are the appropriate temperature and humidity levels for storage of paper objects?	J:6
How does light affect paper objects?	J:7
How do I protect paper objects from light?.....	J:7
How can I tell if a paper object has been damaged by light?.....	J:8
What is the impact of gaseous pollutants on paper objects?	J:8
What is the impact of particulates on paper?	J:9
How do I protect paper objects from dust and gaseous pollutants?	J:9
What impact do acids have on paper objects?.....	J:10
How do molds and pests affect paper objects?.....	J:10
D. Collections Maintenance	J:11
What is appropriate collections maintenance for a paper collection?	J:11
E. Handling Paper Objects	J:13
What are appropriate handling guidelines for paper objects?.....	J:13
What are appropriate supports for handling paper objects?	J:14
How do I handle rolled paper objects?	J:15
How do I insert or remove an object from a polyester enclosure?	J:15
F. Storing Paper Objects	J:16
What are the guidelines for storing paper collections?	J:16
What are acid-free and archival materials?	J:16
How do I know which archival paper products to use with the various types of paper objects?.....	J:17
How do I know which plastic products to use with the various types of paper objects?	J:18
Are there any other situations when I should not use plastic products for storage?.....	J:19
What are diazotype reproductions and how should I store them?	J:19
What specific types of enclosures are available for paper objects?	J:19
What kinds of equipment should I use to store collections of paper objects?.....	J:22

G. Exhibiting Paper Objects	J:23
How can I limit the risks of exhibiting paper objects?	J:23
Which formats are appropriate for displaying paper objects?	J:24
What guidance is available for matting and framing paper objects?	J:24
H. Working with a Conservator When Treatment is Needed	J:25
How do I know which objects require conservation treatment?	J:25
What is stabilization versus treatment?	J:25
What restoration treatments are appropriate for paper objects?	J:25
What cleaning techniques are appropriate for paper objects?	J:26
Can acidity be removed from paper to prolong preservation?	J:26
Are deacidification sprays appropriate for use on paper collections?	J:26
I. Emergency Procedures for Paper Collections	J:26
J. Glossary of Terms Used to Describe Paper Condition	J:27
K. Selected Bibliography	J:28
L. Selected World Wide Web Resources	J:29

List of Figures

Figure J.1	Suitable Temperature and Humidity Levels for Paper Storage	J:7
Figure J.2	Suggested Maximum levels of Major Gaseous Pollutants	J:9
Figure J.3	Types of Enclosures	J:20
Figure J.4	Types of Polyester Enclosures	J:20
Figure J.5	Types of Boxes	J:21
Figure J.6	Archival Separation Sheet	J:30
Figure J.7	Example Handling Procedures	J:31

APPENDIX J. CURATORIAL CARE OF PAPER OBJECTS

A. Overview

1. *What information will I find in this appendix?*

This appendix discusses the physical character of paper objects and provides guidance for their long-term preservation. The types of paper objects included in this discussion are:

- archival and manuscript materials (documents, letters, field notes, reports, and project data)
- prints and drawings
- maps
- architectural records

Note: Archival and manuscript materials make up the largest part of NPS museum collections, so most NPS paper objects are part of an archival collection. Be sure to have your park's archival collections surveyed and appraised by an archivist before you give attention to individual items within a collection. This will help you set preservation and treatment priorities. See Museum Handbook, Part II: Museum Records (MH-II), Appendix D: Archives and Manuscript Collections, for additional information.

The main topics covered in this appendix are:

- the nature of paper
- agents of deterioration
- preventive conservation (collections maintenance, handling, storage, and exhibition)
- working with a conservator when treatment is needed
- emergency procedures for paper objects
- glossary of terms used to describe condition

This appendix does not address the care of photographs (see Appendix R: Curatorial Care of Photographic Collections) or books (see *Conserve O Gram* 19/2, "Care and Security of Rare Books").

2. *Why is it important to practice preventive conservation with paper objects?*
- The role of preventive conservation is to avoid, block, or minimize the **agents of deterioration**. This practice will decrease the need for costly and time-consuming conservation treatments and irreparable harm to objects.
- Poor environment, storage and exhibit techniques, and careless handling easily damage papers. Once the object is stained, embrittled, torn, or creased, it becomes even more fragile. Conservation treatment cannot reverse all damage to an object. Treatment can be expensive. It is unlikely that your park can afford to treat all objects, especially those with little exhibit or monetary value. Preventive conservation is cost effective because care is provided for the collection as a whole, rather than object-by-object.
3. *How do I learn about preventive conservation?*
- Read about the agents of deterioration that affect paper objects so that you can create a preventive conservation plan. These agents are discussed in more detail in Section C. Understanding how to protect your collection from the agents of deterioration will lengthen the life of your paper objects. See Chapter 3: Preservation: Getting Started, and Chapter 4: Museum Collections Environment, for a complete discussion of the agents of deterioration.
4. *Where can I find the latest information on care of these types of objects?*
- There are a variety of sources for up-to-date information about paper:
- Read the issues in the NPS *Conserve O Gram* series relating to paper.
 - Review the references in the bibliography.
 - Look up the World Wide Web sources that are listed at the end of this appendix.
 - Consult a paper conservator.
 - Consult a curator or archivist of a paper/archival collection.
5. *What should I know about the history of papermaking?*
- Collections may contain a variety of papers that have been used in many ways to produce records and other paper objects. Objects predating the mid-19th century are fairly uniform in character. Paper objects produced after this period vary widely in structure and composition as well as in permanence. *Papermaking* by Dard Hunter provides an excellent history of the technology of papermaking (see Section K. Selected Bibliography). In short:
- Paper was invented in China more than 2,000 years ago. It was made by hand from naturally occurring plant fibers, and was for centuries a scarce and expensive commodity. Because the process was a closely guarded secret, papermaking technology was not imported to Europe until the Middle Ages.
 - The first American paper mill was established in the late 17th century. By the early 19th century, there were almost 200 mills in the United States making handmade paper from rag fibers.
 - Advances in technology during the Industrial Revolution made abundant, inexpensive paper possible. Handmade paper was replaced

by mass-produced, machine-made paper. The demand for fiber was met by adding wood pulp to rag fibers. The cheapest paper, made entirely of groundwood pulp, was used for printing newspapers, broadsides, and other commercial products. Groundwood pulp paper is inherently unstable chemically.

- Higher-quality machine-made papers include more extensively processed fiber and/or some rag fiber. Some applications, like photography, require truly high quality paper made entirely of rag fibers.

6. *What is the difference between paper and a paper object?*

Paper itself is only part of a paper object. It is often referred to as the *support*. Equally important are the media used on the paper to form a paper object, such as:

- inks
- graphite
- colored pencils
- wax crayon
- pigments and binders (watercolor, pastels)

These are hand-applied media. Media also can be applied mechanically or reprographically. Mechanical processes of reproduction using the medium of printer's ink include:

- letterpress
- engraving
- wood block
- etching
- lithography

Some modern reprographic processes are:

- mimeography
- xerography

Each one of these use a wide variety of inks, pigments, and binders.

B. The Nature of Paper Objects

1. *What is the structure of paper?*

A sheet of paper is actually a web of fibers held together by their physical entanglement and weak chemical bonds between the fibers. The fibers in paper are primarily cellulose. Materials are added to the fiber to control the properties of the paper, such as absorbency and smoothness. Those

additional materials include:

- **Sizing.** Chemicals added to paper to make it less absorbent so inks will not bleed. Acidic sizings, such as alum-rosin, can cause paper to deteriorate.
- **Fillers.** Materials like clay are used to create very smooth and shiny surfaces for high quality illustration, such as glossy art book paper.

2. *What is cellulose?*

Cellulose is the basic chemical polymer of all plant fibers. The molecules have a long chain-like structure that is both strong and durable. At the same time, the structure is moisture-sensitive and vulnerable to acidic deterioration.

3. *What fibers have been used historically to make paper?*

Many different fibers have been used to make paper. These can be grouped into three types according to the source of the fiber:

- cotton and linen rags
- bast (flax, Japanese paper mulberry, hemp)
- wood

The common element of these fiber sources is cellulose.

In early paper, **cotton and linen fibers** were used to make paper by hand. As the need for paper exceeded the supply of fibers, recycled plant fibers were obtained from cotton and linen rags. The term “rag” paper applies to any paper made solely from cotton or linen cloth fibers. European-style paper objects dating from before the mid-19th century almost always are made of rag paper.

Other fibers like **grass** are quite rare, and are unlikely to be found in NPS collections.

Wood-pulp paper (or groundwood paper) is the most prevalent paper in NPS museum and archival collections dating after the mid-19th century, when technology was developed to extract fiber from lumber. This process made paper inexpensive and abundant. However, the **paper made from groundwood pulp is highly acidic and inherently unstable.**

4. *What causes groundwood paper to be unstable?*

Groundwood paper contains cellulose as well as other materials that occur naturally in wood. One of these, *lignin*, is a plant protein which is inherently unstable and generates acid as it deteriorates. Acid generated by the deteriorating lignin breaks the cellulose chains, making fibers shorter and weakening the paper. Groundwood paper begins to deteriorate as soon as it is made.

Some groundwood pulp is chemically treated to remove all but the cellulose fibers. This “chemical woodpulp” paper is not as strong or stable as rag paper because the fibers are short. However, it is not self-destructive like the groundwood paper because the acid-generating properties have been removed.

5. *How is paper quality judged?*

The quality of paper is determined by its durability and permanence. The degree to which paper retains its original strength during its history is called

durability. The degree to which paper remains chemically stable and resists deterioration is called *permanence*. See Section C.10 for a discussion of permanence related to acidity and pH.

6. *How does the nature of some paper objects affect their preservation?*

Every paper object is a combination of fibers, adhesives, and media. If any of these elements are unstable, the paper object will be inherently unstable and will deteriorate. Common examples are:

- manuscripts with iron gall ink on rag paper sized with gelatin. The gelatin size originally served to control absorption of the watery ink, preventing the ink from bleeding into the paper. As the size degrades, any water applied will be quickly absorbed into the paper. Iron gall ink can contain sulfuric acid that eats into the paper, most severely where it was thickly applied. The iron gall ink also fades from its original black to brown. Although the rag paper is sturdy and durable on its own, the deterioration of the ink compromises the stability of the object.
- pencil drawings on tracing paper. Some tracing paper is rendered transparent by an impregnating resin. Over time, the resin oxidizes, darkens, and causes the paper to become brittle. The graphite is chemically stable, but may be lost by abrasion, rubbing, or smudging.

Even when all the paper object's elements are stable, they may not respond positively to environmental changes. Two examples are:

- a tightly framed print. The print paper may be a high quality rag paper and the printing ink a stable one composed primarily of carbon. However, if the print is housed in poor quality framing materials, it will be damaged. Wood backing boards can discolor the print. If the print is held tightly in the frame without a window mat to allow expansion and contraction of the paper with changes in humidity, wrinkles and even tears can result.
- paper repaired with a paper patch. Paper expands and contracts as the relative humidity rises and falls, usually more so in one direction than the other. This can be due to the *grain* of the paper. The dimensional change is less in the direction of the grain rather than across. If the grain of the paper patch is not parallel to the grain of the paper object, the patch and the object will expand and contract in different directions. Over time, this results in *cockles*, or warping of the paper object.

C. Agents of Deterioration

1. *What causes paper to deteriorate?*

The deterioration of paper may result from:

- inherent conditions (poor quality pulp, bleaching residues, unstable sizings, acidic inks)
- external conditions (fluctuating temperature and relative humidity, light exposure, air pollution, pests, contact with acidic materials, careless handling, improper storage, natural disasters, accidents)

Inherent and external conditions often reinforce each other to promote further deterioration. See Chapter 4: Museum Collections Environment for a discussion of the impact of external (environmental) conditions on

museum objects, and Chapter 5: Biological Infestations for a discussion of pests.

Paper is fragile and susceptible to deterioration caused by *inherent vice*. The nature of the materials and sometimes methods of manufacture, cause deterioration that may not be treatable. Good preventive conservation practice can minimize the effects of inherent vice and extend the useful “life” of a paper object.

2. *How does temperature affect paper objects?*

High temperatures cause brittleness, particularly in groundwood paper. Most of the chemical reactions that cause paper to deteriorate proceed twice as fast with each 10°F increase of temperature. Gelatin adhesives shrink and relax as temperature fluctuates.

3. *How does relative humidity affect paper objects?*

Cellulose is *hygroscopic*—it has a physical attraction for water, making relative humidity (RH) one of the critical factors for paper preservation. Paper contains water within its chemical structure and water is also bound loosely to its surface. The water in paper is in equilibrium with the water (humidity) in the air. As the relative humidity (RH) drops, paper gives up water to maintain this equilibrium. It contracts physically, becoming smaller as it loses water.

Paper gives up the loosely bound surface water first. Once the surface water is gone, the paper is forced to give up structural water. While surface water can be regained after the humidity rises, the loss of structural water is permanent. This desiccation causes embrittlement. Some media, such as inks and gum-based watercolors, are similarly responsive to changes in RH.

Paper requires a certain amount of moisture to be flexible. Desiccated or brittle paper is:

- less flexible and more subject to damage from handling
- more easily torn during unrolling
- more easily broken when flexed

High relative humidity (above 68%) encourages insect infestation and mold growth. Fluctuating relative humidity:

- causes stress from continual expansion and contraction (particularly damaging to objects composed of more than one material)
- damages materials that are constrained (such as a tight binding, adhesive repair, or fastener)
- causes buckling and cockling to materials that are partially constrained (such as repairs or mounts)

4. *What are the appropriate temperature and humidity levels for storage of paper objects?*

Store paper objects in a stable environment at a constant temperature between 60°-65°F (+/-3°) and a relative humidity of 40% (+/-3%). Photographs should be stored at slightly cooler and drier levels. See Figure J.1. below.

	T (+/-3°)	RH (+/-3%)
Paper Objects and Human Occupants	65°	40%
Paper Objects Storage	60°	40%
Photograph Storage	50°	35%
Isolated Color Photograph Storage	40°	35%
These numbers are based on NISO TR01-1995 “Environmental Guidelines for the Storage of Paper Records.”		

Figure J.1. Suitable Temperature and Humidity Levels for Paper Storage

5. *How does light affect paper objects?*

Both visible light and ultraviolet (UV) radiation cause serious damage to paper objects. The degree of light-sensitivity depends on the nature of the materials and media. For example:

- Groundwood paper quickly turns brown and brittle because the damage from inherent acidity is accelerated by light exposure.
- Rag fibers are fairly stable, but may be stained or bleached by light exposure, depending on the properties of the sizing.
- Colored materials made of dyes (colored papers, colored pencils and crayons, ballpoint and felt-tip pen inks) fade quickly.
- Watercolors are particularly sensitive because the medium contains little dye or pigment.
- Certain photographically produced images (blueprints, sunprints) fade quickly with light exposure.

6. *How do I protect paper objects from light?*

To protect paper objects from light damage:

- Eliminate all sources of UV from exhibition, storage, and curatorial work areas.
- Keep exhibit area light levels below a **maximum** of 50 lux (5 footcandles).
- Control duration of exhibition to a **maximum** of 6 months. After a paper object has been exhibited for a total of 6 months, consult a conservator before each additional proposed exhibition. If the object is fragile, consult a conservator before the initial exhibition. See Section G. for alternatives to exhibiting original objects

Note: Use the Exhibits Associated Module in ANCS+ to track the periods of time that an object is exhibited. You can then calculate the total time that the object has been exhibited. You will need to check individual loan records to determine whether an object was exhibited while on loan.

- Keep lights off in storage areas when they are unoccupied.

- Turn off lights when no one is in exhibit areas for extended periods of time.

Some design media are very stable when exposed to light. These include pure minerals such as:

- graphite
- most black printing inks

Where these media were used, the preservation of the object depends on the quality of the paper. For example, an 18th century broadside composed of black ink on rag paper can be exhibited using the maximum conditions stated above.

The effect of light on paper objects is cumulative and irreversible. Do not exhibit original papers for more than six months (cumulative), except in consultation with a conservator. Maintain light levels at 50 lux (5 footcandles) maximum.

7. *How can I tell if a paper object has been damaged by light?*

If a paper object has been exposed uniformly to light, fading or discoloration may be uniform and difficult to identify. If the object has been partially covered by a mat, check underneath the mat where the object has been protected, to see if the color is different.

Note: If the cover mat was of poor quality, the mat might have stained the paper object. It may be difficult to determine whether deterioration is a result of light damage, staining from the mat, or a combination of factors.

8. *What is the impact of gaseous pollutants on paper objects?*

Sulphur dioxide, nitrogen dioxide, and ozone are the primary gaseous pollutants that adversely affect paper collections (Wilson 1995). They are especially damaging when RH, temperature, and light exposure are high.

Oxides of nitrogen and sulfur combine with moisture from the atmosphere to form acids. Groundwood papers are especially vulnerable to acid attack (see Question 11. below, for sources of acid deterioration).

Other gaseous pollutants that may impact paper collections include:

- Acids
- Formaldehyde (used in plywood, particle board, certain foams and synthetic materials)
- Hydrocarbons
- Sulfides

Note: Most gaseous pollutants can be eliminated through the use of air purifiers (Wilson 1995). See *Tools of the Trade* for additional information.

<u>Pollutant</u>	<u>Volume in parts per billion</u>
Sulphur dioxide	5-10
Nitrogen Dioxide	5-10
Ozone	5-10

These recommendations are based on numbers from NISO TR01-1995
“Environmental Guidelines for the Storage of Paper Records.”

Figure J.2. Suggested Maximum Levels of Major Gaseous Pollutants

9. *What is the impact of particulates on paper?*

Particulates come from several sources and can damage paper in many ways. For example:

- Sharp particles (sand, dirt) abrade paper and design media as they are dragged across the object’s surface.
- Oily particles from engine exhaust, cigarettes, or cooking smoke may become embedded in paper fibers soiling the paper and providing food for mold and insects.
- Dust that is acidic or contains metal particles accelerates the chemical deterioration of paper.
- Dust contamination can cause irreversible deterioration because paper is fibrous and absorbent. Surface dust can usually be reduced, but rarely removed completely.
- Dust fibers can hold moisture in contact with objects and facilitate mold growth.

10. *How do I protect paper objects from dust and gaseous pollutants?*

Where practical, locate collections in storage and on exhibition away from:

- roadways
- loading docks
- parking lots
- outside doors
- photocopy machines
- woodworking and maintenance shops, and other sources of on-going pollution

<i>DO....</i>	<i>DON'T....</i>
remove paper from locations being painted	return paper to newly painted storerooms or exhibit cases until paint is thoroughly dry and fumes are gone
control dust through filters in ventilation systems, vacuuming, and dusting.	move dust around with brooms or redistribute dust by using vacuums that don't retain the dust in a filter

11. *What impact do acids have on paper objects?*

Acids are the primary cause of paper deterioration. They cause paper to become weak, brittle, and stained. The source of acids in paper include:

- materials used in the papermaking process, especially from 1850 to the present, such as alum-rosin sizing and lignin groundwood pulp
- residual bleaching chemicals, unstable iron gall ink, air pollutants
- direct contact with acidic materials (file folders, adhesives, mat boards, wood, unstable plastic sheeting)
- exposure to acidic vapors from closed document boxes or wooden storage drawers

Acids move from acidic materials (such as wood) to objects of reduced or no acid (such as rag paper). The rate of this *acid migration* is dependent on the moisture present. It is accelerated in humid conditions.

The concentration of acid is measured on the pH Scale, with numbers ranging from 0 to 14. The number 7.0 on this scale is neutral. All numbers below 7.0 indicate an *acidic* condition. All numbers above 7.0 indicate a basic or *alkaline* condition. The pH scale is logarithmic—a paper object with a pH 3.0 contains 10 times as much acid as an object with a pH 4.0, and 100 times as much acid as paper with a pH 5.0. **A desirable pH range for paper is 6.5 to 8.5.**

12. *How do molds and pests affect paper objects?*

A complete description of the biological agents that affect museum objects can be found in Chapter 5: Biological Infestations.

Molds normally thrive in damp environments (RH levels over 65%) with still air. Molds:

- feed on fibers, sizings, coatings and adhesives
- grow on any material that provides moisture and organic nutrients
- destroy the sizing in paper

- cause patches of staining or discoloration
- leave paper structurally weakened and chemically altered

Insects consume parts of paper and leave damaging waste products on the surface. The types of insects that damage paper include:

- **bookworms** (the larval stage of the drugstore and cigarette beetle). Powder and small round holes in book covers or text block indicate an active infestation of bookworms.
- **silverfish** often eat partially through paper. Damage from silverfish can be found particularly in non-design areas of prints and watercolors.
- **cockroaches** feed on the ragged edges of paper and cardboard. Cockroach excrement also causes damage.
- **the common fly** seeks shelter in books or framed paper objects. Their acidic excrement is damaging to paper.

Mice can damage or destroy large collections of unprotected papers. Look for their nests by observing the concentration of droppings.

Your park should have an Integrated Pest Management (IPM) Plan, as well as a Housekeeping Plan and/or a Preventive Conservation Plan. These documents will provide you with important preventive conservation information for paper collections. In addition to regular monitoring, be sure to:

- inspect and isolate all incoming collections
- periodically monitor inside boxes, storage cabinets, exhibit cases, and other closed containers for evidence of pests and mold

D. Collections Maintenance

The park curator has primary responsibility for preventive care of museum collections. In addition to monitoring and controlling the environment, and recognizing symptoms of deterioration of collections, the curator needs to know appropriate techniques for:

- collections maintenance
- handling
- storage
- exhibition
- transportation of collections

1. *What is appropriate collections maintenance or a paper collection?*

The goal of preventive maintenance is to stabilize the collection and minimize the effects of deterioration. There are many non-interventive treatments that curatorial staff can undertake for preservation. For example:

- Remove dust from an item using an air bulb syringe.
- Use a soft artist's or cosmetic brush to gently remove loose dust before handling or storage of paper objects.
- Replace soiled or acidic folders with new, archival folders (acid-free or buffered depending on paper object). File names and other labels must be carefully copied onto the new folders. Retain old folders that contain any annotations that cannot be transcribed, such as sketches.
- Do not overfill folders.
- Remove original fasteners including staples, paper clips, string ties, rubber bands, brads, and straight pins (consult *Conserve O Gram* 19/5, "Removing Original Fasteners from Archival Documents"). Maintain the order and relationship of documents when removing fasteners. If a multi-page document cannot be feasibly stored without fasteners in its own acid-free folder, consult *Conserve O Gram* 19/6, "Attachments for Multi-Page Historic Documents."
- After removing deteriorated rubber bands from rolls of drawings, store the rolls in an acid-free tube. If the sticky residue from the rubber bands does not readily come off, interleave or cover the area with silicone release paper to keep it from sticking to other papers or the storage container.
- Remove stained prints from acidic mats. **Note:** Do not attempt to remove the print if it is glued to the mat. Removing materials that are adhered to an object goes beyond stabilization. A paper conservator should treat this condition.
- Protect documents from acidic newspaper clippings. If the clippings must be left in place:
 - sleeve the clipping in a stable polyester folder (see Figure J.4., Types of Polyester Enclosures), or
 - interleave between the clippings and other documents with buffered paper

If you can safely remove the clippings, photocopy the clippings onto archival paper and place the photocopies with the other documents. Store the original clippings separately. Some archives do not retain unannotated original clippings because of their acidity. The curator should make this decision based on the significance of the clippings, the park's storage capabilities, and other preservation and interpretive requirements, in consultation with the regional/SO curator.

- Unfold papers, such as correspondence, and store flat. Flat storage is preferable to rolling for all papers small enough to fit in map case drawers. Refer to *Conserve O Gram* 13/2, "How to Flatten Folded or Rolled Paper Documents."

Note: This procedure requires great care. If the papers are damaged or brittle, and in danger of cracking, request the assistance of a paper conservator before attempting to unfold and flatten them.

You may sometimes need to separate objects, such as dissimilar materials that have different storage requirements. For example, photographic prints and negatives often are removed from a series of papers and stored with other prints and negatives in individual sleeves. In this case:

- Complete and insert an *Archival Separation Sheet* (see Figure J.6) in place of the removed item. Archival Separation Sheets are available in ANCS+.
- Enclose a photocopy on archival paper of the photographic print in place of the original
- Note the original and new locations of negatives and prints in both locations

You can isolate incompatible materials with barriers (sleeves, interleaving sheets), or by planned rearrangement, for preservation reasons. With careful notations, you can preserve the papers' proper relationships.

E. Handling Paper Objects

1. *What are appropriate handling guidelines for paper objects?*

Historic paper objects often are in fragile condition and require more than ordinary care to handle them safely. Require all collection users, be they outside researcher or park/center staff, to receive proper handling guidance before they are allowed to access collections. Review procedures in Chapter 6: Handling, Packing, and Shipping, and *Conserve O Gram* 19/17, "Handling Archival Documents and Manuscripts." **Damage from mishandling is preventable.**

To prevent mishandling of collections, be sure to:

- Prohibit food, drink, and live plants from all collection areas.
- Prepare a written set of procedures for handling (see the example in Figure J.7).
- Enforce the procedures; they only work if you consistently enforce them.
- Require all users to have clean hands and wear clean, white cotton gloves at all times while handling collections.
- Limit handling, and limit the number of people who handle objects.
- Provide a clean and uncluttered workspace.
- Provide each object with appropriate support.
- Ensure that staff with collections responsibility supervise handling by other staff and outside researchers.

- Use facsimiles or duplicates in place of rare or fragile originals (see *Conserve O Gram* 19/4, “Archives: Preservation Through Photocopying”).

The light and heat from repeated photocopying can damage original documents. Limit photocopying to the minimum needed for preservation, exhibit, and other use.

<i>DO...</i>	<i>DON'T...</i>
Wash your hands, remove all jewelry, and wear clean, white cotton gloves at all times	Hold an object by one corner
Always use both hands.	Grasp a rolled object; it can be crushed easily
Allow the weight of the paper or roll to rest in your hands	Flex the paper when placing it onto a support
Place the support on the same level as the object and slide the object onto the support	

2. *What are appropriate supports for handling paper objects?*

The types of supports necessary for safe handling depend on the format and condition of the paper object. The purpose of the support is to relieve the object of the strain of its own weight. **Always handle the object by its support.** Supports may be:

- **long-term**, such as housing or storage enclosures
- **short term**, such as a rigid sheet of paperboard to move the object from one location to another

Examples of appropriate supports for specific situations include:

- an acid-free folder for a manuscript letter on rag paper in good condition
- polyester encapsulation for a fragile architectural plan on tracing paper that has undergone conservation treatment and the pH is stable

Following are additional considerations for handling supports:

- Lightweight, rigid materials, such as archival corrugated cardboard are useful for moving single paper objects by hand.

- Closed supports (archival folders or portfolios) provide more protection than single sheets of cardboard, or open trays.
- Closed supports, such as boxes or portfolios on rolling carts, are good methods of transporting paper objects some distance, particularly if there are any tripping hazards or tight fits

3. *How do I handle rolled paper objects?*

Do not attempt to unroll brittle or desiccated papers. These require treatment by a conservator before viewing. Flexible rolls can be viewed even if the edges tend to curl. Small weights, such as squares of polished glass, weight bags (available from various archival supply companies), or 35mm film cans filled with lead shot can be used to hold down the object's edges. The weights must be smooth and clean to prevent damage to the paper.

If the object is too long for the available table space, it can be "scrolled." To scroll through a rolled object:

- Unroll only as much as can be supported by the examination surface.
- After examining the exposed part, re-roll from the free end (this gives you two rolls).
- Shift the position of the object carefully so that more can be unrolled.
- Proceed this way until the entire object has been viewed.
- Work slowly and cautiously. The edges of tears tend to spring apart and can cause the object to be torn further.

4. *How do I insert or remove an object from a polyester enclosure?*

Objects being inserted into or removed from polyester enclosures are extremely vulnerable to tearing because of the static charge on the polyester film. To insert a limp or very lightweight object into a polyester enclosure:

- Use a sheet of 20 lb. acid-free paper as a temporary support.
- Hold the enclosure open and insert the object on its support.
- Allow the enclosure to close, and lightly rub the film with a lint-free cloth (such as cheesecloth) to build up a charge directly over the object. The static charge should help keep the object in place. See also *Conserve O Gram* 13/3, "Polyester Encapsulation."

When removing an object from a polyester enclosure:

- Watch carefully and go slowly.
- Cut through the polyester if the enclosure is sealed on four sides. The least strain is placed on the object if the seals are cut.
- Remove the top layer of polyester by rolling it up if the enclosure is open on 3 sides.
- Separate the top sheet of polyester by lifting its free corner if the enclosure is sealed with an L-seal.

- Cut a second side, then separate the sheets of polyester on a single-opening enclosure by inserting a microspatula or other flat tool.
- If possible, insert a piece of acid-free paper under the object for support as you remove the object from the enclosure.

The static charge that holds the paper object in the polyester enclosure is a disadvantage when you want to remove the enclosure. If the paper does not release easily from the polyester, gently slide a microspatula between the paper and enclosure, following with the acid-free support paper. If the edges of a torn paper adhere to different sheets of the polyester film, also use the spatula to release one edge and hold that edge in place while you remove the film.

F. Storing Paper Objects

1. *What are the guidelines for storing paper collections?*

See Chapter 7: Museum Collection Storage, for standards and requirements, assessing needs, and planning spaces. You can find information on storage supplies and equipment in Chapter 7, *Tools of the Trade*, and *Conserve O Gram* 4/1, "Museum Storage Cabinets." For archival storage and handling information, consult *Conserve O Grams*:

- 4/1 "Museum Storage Cabinets."
- 19/15 "Storing Archival Paper-Based Materials"
- 19/16 "Housing Archival Paper-Based Materials"
- 19/18 "How to Care for Bound Archival Materials"

Like many other items, paper objects require housings for protection and safe handling in storage cabinets and on shelves. Within the storage environment, housings and enclosures provide the most immediate protection for paper objects. The purpose of the housing system is two-fold, it:

- facilitates the physical organization of the collection
- provides an environment that is as chemically and physically stable

Enclosures are in prolonged and direct contact with objects so it is critical that enclosure materials meet certain specifications. Products of this type are usually called *acid-free*, or *archival*. Scientists at the National Archives and Records Administration (NARA) and Library of Congress are actively engaged in developing standards and testing materials to be used near paper objects. The NPS Museum Management Program acts as a clearinghouse for information on appropriate museum collections storage materials. *Tools of the Trade* and the *Conserve O Gram* series provide updated information on appropriate materials. New developments are also posted to various conservation web sites (see Section L. below).

2. *What are acid-free and archival materials?*

Acid-free and *archival* are general names applied to a variety of plastic and paper products designed for use in proximity to museum objects. When used for the sleeves, boxes, and folders that store paper objects, these products must be free of acid, lignin, alum, and sulfur. The four most commonly used terms are as follows:

- **Archival quality** is a generic term indicating that the product is appropriate for use in contact with your collection objects.
- **Acid free** is also a general term indicating that the product is free of acids, or has a pH of approximately 7.0. This term is often used incorrectly to describe materials that contain alkaline buffers.
- **Alkaline-buffered** products contain an alkaline compound (such as calcium carbonate) designed to neutralize any acids that are present, or retard the evolution of acids in the future. Alkaline-buffered products are often used to interleave between paper objects that might transfer acids to surrounding objects, and generally are in the pH 8.5 range.
- **Unbuffered** or **nonbuffered** products have no alkaline reserve. Generally, they are a neutral pH (7.0) or acid-free material.
- **100% rag** paper products are made exclusively of cotton fibers. Although of good quality, 100% rag paper products do not meet the standards of permanence necessary for the long-term storage of museum collections.
- **Lignin-free** and **pure alpha-cellulose** are terms used to describe some manufactured storage papers, boxes and cardboards. These are made from woodpulp fibers that remain after the lignin is chemically removed.

Two other terms you may see are **neutral** and **inert**. *Neutral* applies to materials that have a pH of around 7.0. You may find this term applied to both paper and plastic materials. The term *inert* is most often applied to materials like polyester film and acrylic sheets like Plexiglas®. It means that the material will not react chemically with your paper objects.

3. *How do I know which archival paper products to use with the various types of paper objects?*

Buffered paper can prolong the life of an enclosure, and absorb excess acidity from the papers contained inside. Be sure to periodically check buffered enclosures and interleaving papers for acidity. Acids can migrate back to the original documents if you do not replace old enclosures and interleaving papers when necessary. Use a pH testing pen to test acidity levels of enclosures and interleaving papers.

Note: Alkaline buffering damages some paper objects. For example, the buffer alters blueprints.

The following chart lists various paper objects paired with appropriate enclosure papers. Contact a paper conservator for assistance if you are uncertain about appropriate products to use with your collection.

Store Using <i>Buffered</i> Materials	Store Using <i>Unbuffered</i> Materials
Flat documents	Leather albums and collages with wool or silk components
Manuscripts	Blueprints
Maps	Hand tinted materials (may include some maps, prints, and drawings)
Most papers (see exceptions under unbuffered materials)	Diazo reproductions
Posters	Friable media (especially charcoal and pastel) should be stored in shallow boxes
Prints and drawings (see exceptions under unbuffered)	Watercolors and photographs

Some products are not available in unbuffered form except by special order. Buffered stock can be lined with polyester film to prevent the object from contacting the buffered paper. *Tools of the Trade* contains information on many of the typical products used in NPS museums for storing paper objects.

4. *How do I know which plastic products to use with the various types of paper objects?*

All plastic materials used for collection storage must be chemically inert. Acceptable plastics are free of powders, coatings, plasticizers, and other additives. Information on the exact composition of plastics should be available from the distributor. See *Tools of the Trade*, Chapter IX: Equipment and Supply Sources, for a listing of vendors.

Common Plastic Products	
<i>Use...</i>	<i>Avoid...</i>
<ul style="list-style-type: none"> • stable polyester • polyethylene • polypropylene 	<ul style="list-style-type: none"> • polyvinyl chloride (vinyl, PVC) • polystyrene

Archival polyester film is the housing material most commonly used for paper collections. It is one of the most dimensionally stable and chemically inert plastics available. However, this and other plastics can develop a static charge that can attract loose media. Do not use plastic housings for objects with:

- powdery or friable media (charcoal or pastel)
- drawings or documents in graphite pencil
- objects with cracking or peeling media
- very deteriorated iron gall ink

5. *Are there any other situations when I should not use plastic products for storage?*

Do not encapsulate papers or house them in polyester sleeves if you cannot maintain proper environmental levels in your storage and exhibit areas. An improper environment can cause moisture to become trapped inside polyester enclosures. Such moisture can damage the object.

6. *What are diazotype reproductions and how should I store them?*

Diazotype reproductions are the familiar white paper with blue print used to print plans, maps, and similar oversized documents. Diazotypes off-gas ammonia that can damage other documents; **be sure to store diazotypes separately in their own cabinet.**

7. *What specific types of enclosures are available for paper objects?*

There are a wide variety of commercially available enclosures for paper objects. See *Tools of the Trade* for descriptions and vendors. While commercial products will be appropriate for most materials in your collection, you may need to make custom enclosures for oversized or oddly shaped objects, and those in very fragile condition. Figure J.3. lists common enclosures, their uses, and cautions about their uses.

Figure J.3. Types of Enclosures

<i>Enclosure type</i>	<i>Sizes</i>	<i>Typical Uses</i>	<i>Cautions</i>
10 point paper folders	Standard (10" x 12") Legal (10" x 15")	Small, flexible objects in good condition	Do not use if paper object is brittle
20 point paper folders (map folders)	Sizes over 20" x 24"	Small to medium sized objects requiring more support than 10 point folders offer	
20 lb. paper folders	Standard and legal	Light-weight folders used within 10 point folders to protect fragile documents stored vertically in document boxes	These folders are suitable only for single sheets and sets of sheets in good condition
20 lb. paper interleaving sheets	Letter size (8 ½" x 11") Legal size (8 ½" x 14")	Placed between objects in a folder; segregating paper objects in good condition from newspaper clippings	
Polyester enclosures (also see Figure J.4., Types of Polyester Enclosures)	Various sizes; several weights and thicknesses (1, 3, 5 and 10 mil)	Housing fragile or torn objects that can be kept together by the static attraction of the enclosure	Can tear fragile paper if not opened carefully; not appropriate for powdery or flaking media (charcoal, chalks, pastels, desiccated paint and inks)
Matboard enclosures	Can be made to size (see <i>Conserve O Gram</i> 13/1, "Window Mats for Paper Objects"), 2, 4, and 8-ply thickness	Appropriate for objects being framed for exhibit; added support for objects in polyester sleeves; use thicker types as supports for carrying objects	Thinner boards are flexible and not appropriate for brittle objects; avoid covering edges or face of fragile media with matboard
Corrugated paperboard	Single or double-walled construction; available in sheets 24" x 48" and larger	Similar uses to matboard; very strong. Use to make customized supports, crease and fold to make wedges to fill space within document boxes	Single-walled boards tend to warp in larger sizes
<i>Enclosure type</i>	<i>Sizes</i>	<i>Typical Uses</i>	<i>Cautions</i>
Boxes (See also Figure J.5, Types of Boxes)	Variety of sizes and designs for vertical and horizontal storage	Appropriate for housing multiple objects in enclosures (mats, folders); three-dimensional objects	Do not overfill or allow to become too heavy to handle easily

Figure J.4. Types of Polyester Enclosures

<i>Type</i>	<i>Description</i>	<i>Uses</i>	<i>Cautions</i>
Folders	Sealed on one side (usually lengthwise)	Temporary housing for fragile single sheets being processed; protect single sheets during handling by researchers	Use care to prevent the document from sliding out the unsealed sides
L-seal pockets	Sealed on two adjacent sides	Appropriate for thin pamphlets, single sheets in fragile condition, single sheets of groundwood paper	Use care to prevent tearing the object as it is inserted into the folder

<i>Type</i>	<i>Description</i>	<i>Uses</i>	<i>Cautions</i>
Sleeves	Sealed on two opposite sides (usually lengthwise)	Used in conjunction with supports for thin objects that cannot be flexed (placecards, photographs)	
3-seal pockets	“Open-short” or “open-long”, depending on which one of the 4 sides is left unsealed	Appropriate for thick pamphlets and bulky objects; used with rigid inserts for objects that cannot be flexed	Open-short format provides more support than an open-long pocket
Multi-pocket sheets	Various sizes with pockets that vary in size depending on the number per sheet	Minimize storage volume for smaller objects such as advertising cards, baseball cards, small photos	Only appropriate for single sheets in reasonably good condition
Encapsulation (see <i>Conserve O Gram</i> 13/3, “Polyester Encapsulation”)	Enclosure sealed on 4 sides with ultrasonic or heat seal, or 3M Scotch Brand Double-coated Tape No. 415 [®]	Used for fragile, brittle, or torn objects and objects subjected to frequent handling	Acidic papers should be treated by a conservator before encapsulation to avoid accelerated deterioration, or add a buffered sheet

Figure J.5. Types of Boxes

<i>Type</i>	<i>Description</i>	<i>Uses</i>	<i>Comments</i>
Document	Sizes from 3” x 5” to 10” by 15”; hinged lids	Used to store groups of objects in enclosures, such as folders; objects are removed by lifting the enclosures up and out	Do not use handles that protrude into the interior of the box that can catch on the enclosures and objects inside the box.
Card	Sizes range from 3”x3”x5” to 8”x5”x10” and may have hinged or separate lids	Prints, computer discs, postcards, stereocards	
Solander or Clamshell (also called Portfolio)	Sizes range from 8”x10” to 20”x24”; clamshell boxes are hinged and open completely flat	Used for horizontal storage of paper objects, usually in mats or folders; suitable for works of art on paper	Store objects of different dimensions in standard sized enclosures sized to the box to prevent shifting or sliding in the box
Garment, quilt, oversized	Lidded boxes ranging in size from 13”x15”x10” to 16”x58”x6” and made of heavy corrugated paper or polyethylene board	Suitable for oversized objects or groups of smaller boxes; can be fitted with compartment dividers	Do not overfill
Archival Records Storage	10”x12”x15” boxes with hand holes cut into either end for carrying; lift-off lid; corrugated paper or polyethylene board	Generally used for vertical storage of papers in good to fair condition that are housed in folders	Do not use to hold fragile archival materials or those of high intrinsic value

When choosing any of these products, keep the following in mind:

- have a modular system of standard sizes
- be sure that housings fit snugly inside boxes and drawers so that objects cannot shift or slide

- when storing paper objects together in boxes or drawers, house them in the same size enclosures. Choose the size of the enclosure based on the size of the largest object
8. *What kinds of equipment should I use to store collections of paper objects?*

Be sure to utilize appropriate storage equipment to physically support paper objects in their enclosures. Use storage equipment to:

- protect the collection from abrupt environmental changes
- protect objects from pest infestations
- maximize the available storage space

Only use storage equipment that is constructed of chemically inert materials. Modular storage units afford the most efficient use of space and retrieval of objects. Refer to Chapter 7: Museum Collection Storage and *Tools of the Trade*, for further guidance.

The most commonly used types of storage equipment for paper collections are:

- **map cabinets** (also called flat files)
- **shelving units**

Only store documents vertically in file cabinets if they are in very good condition and are well supported in their enclosures.

Use **flat files** or **map cabinets** to store objects too large for boxes.

- All objects should be in enclosures.
- Map cabinets with shallow drawers are more efficient than those with deeper drawers. Store objects of varying sizes in uniform folders that are the size of the drawer.
- Fill empty spaces with blocks of polyethylene foam.
- Separate stacks of enclosures or rolled papers within a drawer with dividers made of archival cardboard.

Stack objects in piles of 1” or less in flat file drawers.

Use **shelving** to store objects in boxes. Use adjustable shelves and place shelves close enough together that boxes cannot be stacked. Roll oversized paper objects around archival tubes and store on end supports.

G. Exhibiting Paper Objects

It's difficult to find an acceptable balance between the benefits of exhibiting original paper objects and the resulting damage. For objects of high intrinsic value, there is no level of loss that is acceptable. For other objects (duplicates, objects of no intrinsic value), there may be a level of loss that is acceptable, such as fading that is imperceptible to the human eye.

To ensure preservation of papers on exhibit:

- **Obtain a copy of the CD-ROM publication *Exhibition Conservation Guidelines: Incorporating Conservation into Exhibit Planning, Design and Fabrication***, available from the Department of Conservation at Harpers Ferry Center. This resource contains a wealth of guidance on developing preservation-responsible exhibitions.
- **Do not exhibit papers for more than six months** (cumulative). Six months of cumulative exposure to controlled, low light levels (50 lux or less) is the maximum exhibition time for original paper objects. Consult a conservator before exhibiting original objects for longer than six months. **Only facsimiles are appropriate for “permanent exhibits.”** Be sure to distinguish between facsimiles and duplicates as follows:
 - Facsimiles are new copies of the original objects.
 - Duplicates are multiple originals, such as lithographs and blueprints.

In some collections there may be several identical copies (duplicates) of an object, such as a lithograph map. In some instances, it may be appropriate to treat one of the duplicates as a facsimile for exhibition purposes. It is not appropriate to take this approach if those objects have acquired unique characteristics. For example:

- blueprints (originally printed in multiple copies) containing annotations documenting plan changes made during construction
- the only extant copy of an object originally made in multiples

1. *How can I limit the risks of exhibiting paper objects?*

Do the following:

- Control temperature, relative humidity, pests, and air pollution.
- Eliminate all sources of ultraviolet light.
- Limit light intensity to 50 lux or less.
- Use appropriate display materials in formats that properly support the object.

- Limit the duration of exhibit and/or rotate specific objects to and from storage.

2. *Which formats are appropriate for displaying paper objects?*

Paper objects on exhibition require special protection. The exhibit mount must provide physical support to avoid mechanical damage. It also must protect the objects from direct handling. The exhibit case protects objects from vandalism.

Paper objects are exhibited in frames or display cases.

- Frames are appropriate for single sheet objects that are strong enough to be displayed upright in a mat, such as:
 - prints
 - drawings
 - manuscript materials
- Cases are required for objects that cannot be housed safely in a mat, such as:
 - multi-sheet objects
 - oversized objects that can't be framed
 - thick, or heavy objects like books

*Be sure that exhibition mats and mounts are larger than the object to fully protect its edges. **NEVER FOLD OR TRIM AN OBJECT** to fit into a housing enclosure.*

3. *What guidance is available for matting and framing paper objects?*

Consult *Conserve O Grams* 13/1, "Window Mats for Paper Objects" and 13/4, "Exhibit Mounting Variations for Objects on Paper," *Matting and Framing Works of Art on Paper* by Elizabeth Kaiser Schulte, Hilary A. Kaplan, and Chris Foster, available on the web at: <<http://aic.stanford.edu/treasure/matt.html>>, and *Caring for Works of Art on Paper*, on the web at: <<http://aic.stanford.edu/treasure/paper.html>>.

If you hire a commercial framer, request references of other museum customers and be sure to include a scope of work that specifies their adherence to the guidance listed in these publications.

H. Working With a Conservator When Treatment is Needed

Care of NPS museum collections is based on a preventive conservation approach to preserve objects. Sometimes, however, preventive measures are inadequate, and conservation treatment is necessary to preserve an object. Review Chapter 8: Conservation Treatment, for detailed guidance. See Section J, Glossary of Terms Used to Describe Condition, for definitions of paper condition to aid in discussing the needs of your collection with a conservator.

Conservation treatment is active (“hands-on”) work to preserve and/or restore objects. Only trained conservators who have specific expertise should treat paper objects in your collection. If conservation treatment is required, park staff must ensure that:

- objects receive the most appropriate treatment for their preservation and use
- treatment is appropriate (consider the object’s condition, history, significance, and use)
- treatments are performed by skilled, experienced conservators and documented properly

1. *How do I know which objects require conservation treatment?*

It is easy to determine treatment needs if objects are extremely fragile, or damaged in such a way that they cannot be displayed. However, it is important to have an overall plan for dealing with the preservation of your entire collection. Therefore, it is important to have a Collection Condition Survey completed by a paper conservator to identify the entire range of problems, and develop priorities for treatment. A survey also will identify housing issues, and minimally interventive treatments that you can undertake to better preserve the collection.

2. *What is stabilization versus treatment?*

Sometimes stabilization is as simple as removing a paperclip or using buffered paper to prevent acid migration. Stabilization of a torn document may be accomplished through encapsulation, or through mending.

The goal of stabilization is to allow the object to be researched, exhibited, and handled without damage. Work with a paper conservator to determine the amount of stabilization required to meet that goal.

Conservation treatment can actually change the chemical or physical stability of a paper object.

3. *What restoration treatments are appropriate for paper objects?*

Restoration treatments are intended to return objects to a known or assumed former state, often through the addition of non-original material. Keep the following points in mind to determine if restoration is an appropriate option:

- Restoration treatments should be undertaken only if absolutely required for exhibition or research purposes.
- There must be sufficient data about the object’s earlier appearance to enable accurate restoration.
- Restoration must not modify the object’s known original character.

- Restoration should be accomplished using the techniques and materials that will least modify the item.
- Restoration materials should be removable at a later time with minimal adverse effect.
- Restored areas should be distinguishable from original material upon careful examination.
- Restoration and the use of added materials must be well documented.
- All restorations will preserve significant evidence of use and other historical evidence.

4. *What cleaning techniques are appropriate for paper objects?*

You can remove dust from stable media with an air bulb syringe, a soft artist's brush, or a cosmetic brush. Refer all other treatments to a paper conservator.

Note: Some computer-generated documents may have ink/toner that didn't properly bond to the paper originally. Do not use a brush to clean such papers, as you could remove toner from the page. Consult a paper conservator.

5. *Can acidity be removed from paper to prolong preservation?*

Yes. A paper conservator often can use a water-based treatment to reduce paper acidity. There also are various treatments to neutralize acids. However, certain pigments, dyes and inks may fade or change color, and some papers darken with these treatments. A paper conservator will be equipped to determine if these treatments are appropriate.

6. *Are deacidification sprays appropriate for use on paper collections?*

Only a paper conservator should determine whether any form of interventive treatment is appropriate for your collection. These sprays may irreparably change the character of a paper object. **Use only under the guidance of a qualified conservator.**

I. Emergency Procedures For Paper Collections

Your collection is unlikely to be damaged by floods, hurricanes, or tornadoes. However, no park is immune from the threat of emergencies. A broken pipe can do untold damage to a paper collection, causing sheets to stick together and media to run and stain adjacent objects. Both a disaster plan and recovery plan are critical to ensuring the collection's preservation. Review Chapter 10: Emergency Planning for guidance. Make sure that:

- Collection needs are addressed in your park's Emergency Operations Plan
- Local authorities are aware of the special needs of your collections and are familiar with the layout of your exhibition and storage areas
- Sufficient recovery supplies are readily available (see *Conserve O Gram* 21/2, "An Emergency Cart for Salvaging Water-Damaged Objects")

Also review *Conserve O Gram 21/4*, “Salvage at a Glance, Part I: Paper Based Collections.”

J. Glossary Of Terms Used To Describe Paper Condition

Abrasion: surface loss caused by friction

Accretion: deposit of extraneous material on the surface of an object

Brittleness or Embrittlement: loss of flexibility causing paper to break or disintegrate when bent

Cockling: buckling or waving of the paper caused by expansion and contraction under changing atmospheric conditions

Crease or fold: line or mark made by bending or folding the paper

Dent: concave defect in the surface

Deterioration: breakdown of the paper caused by added ingredients or by natural aging

Discoloration: changes in color, such as darkening or fading

Dog-ear: term commonly used to describe a diagonal crease across the corner of a page

Fading: discoloration seen as a loss of color and sometimes with a change of hue

Flaking: lifting and sometimes loss of flat areas of the surface layer

Foxing: brown or reddish-brown spots caused by mold or the oxidation of iron particles in the paper support, mount, or backing

Insect damage: holes, surface loss, or organic residue from insect infestation

Gouge: defect in the surface caused by a blow where material has been scooped out

Loss: missing area or hole

Mold: group of small fungi that grow under warm, moist conditions on organic substrates causing the breakdown of the substrate

Mount: materials to which paper objects are attached for additional support

Substrate: the paper itself

Surface dirt: dirty material either loosely distributed on the surface of an object (dust) or firmly ingrained in the surface (grime)

Tear: linear break in paper resulting from tension or torsion

K. Selected Bibliography

- American Society of Heating, Refrigerating and Air-Conditioning Engineers (ASHRAE). "Chapter 20: Museums, Libraries, and Archives." In *Heating, Ventilating, and Air-Conditioning: Applications. ASHRAE Handbook*. Atlanta: American Society of Heating, Refrigerating and Air-Conditioning Engineers, 2003.
- Appelbaum, Barbara. *Guide to Environmental Protection of Collections*. Madison, CT: Sound View Press, 1991.
- Canadian Conservation Institute. *CCI Notes*. Ottawa: Canadian Conservation Institute, various dates.
- 11/1 Making Protective Enclosures for Books and Paper Artifacts
 - 11/2 Storing Works on Paper
 - 11/3 Glazing Materials for Framing Works on Paper
 - 11/6 Removing Paper Artifacts from Their Frames
- Cohn, Marjorie B. *Wash and Gouache: A Study of the Development of the Materials of Watercolor*. Cambridge: Center for Conservation and Technical Studies, Harvard University Art Museums, 1977.
- Ellis, Margaret H. "Works of Art on Paper," in *Caring for Your Collections*. New York: Harry N. Abrams, Inc., Publishers, 1992.
- Gascoigne, Bamber. *How to Identify Prints*. New York: Thames and Hudson, 1986.
- Hamburg, Doris A. "Library and Archival Collections," in *Caring for Your Collections*. New York: Harry N. Abrams, Inc., Publishers, 1992.
- Hatchfield, Pamela B. and Jane M. Carpenter. *Formaldehyde: How Great is the Danger to Museum Collections?* Cambridge: Center for Conservation and Technical Studies, Harvard University Art Museums, 1987.
- Hunter, Dard. *Papermaking: The History and Technique of an Ancient Craft*. New York: Dover Publications, Inc., 1978.
- National Information Standards Organization. *ANSI/NISO Z39.79 - 2001 Environmental Conditions for Exhibiting Library and Archival Materials*. Bethesda, MD: National Information Standards Organization (NISO), 2001.
- National Park Service. *Conserve O Gram* series. Washington, D.C.: National Park Service, various dates.
- 4/1 "Museum Storage Cabinets."
 - 13/1 "Window Mats for Paper Objects."
 - 13/2 "How to Flatten Folded or Rolled Paper Documents."
 - 13/3 "Polyester Encapsulation."
 - 13/4 "Exhibit Mounting Variations for Objects on Paper."
 - 19/2 "Care and Security of Rare Books."
 - 19/3 "Use and Handling of Rare Books."
 - 19/4 "Archives: Preservation Through Photocopying."
 - 19/5 "Removing Original Fasteners from Archival Documents."
 - 19/6 "Attachments for Multi-Page Historic Documents."
 - 19/7 "Archives: Reference Photocopying."
 - 19/9 "Caring for Blueprints and Cyanotypes."
 - 19/15 "Storing Archival Paper-Based Materials."
 - 19/16 "Housing Archival Paper-Based Materials."
 - 19/17 "Handling Archival Documents and Manuscripts."
 - 19/18 "How to Care for Bound Archival Materials."
 - 21/2 "An Emergency Cart for Salvaging Water-Damaged Objects."
 - 21/4 "Salvage at a Glance, Part I: Paper Based Collections."

National Park Service. *Tools of the Trade*. Washington, D.C.: National Park Service, 2002.

Northeast Document Conservation Center. *Preservation of Library and Archival Materials*, 3rd edition. Lowell, MA: Northeast Document Conservation Center, 1999.

Tétreault, Jean. *Airborne Pollutants in Museums, Galleries and Archives: Risk Assessment, Control Strategies and Preservation Management*. Ottawa: Canadian Conservation Institute, 2003.

Western Association for Art Conservation. *WAAC Newsletter* 22, no. 2 (2000).

William K. Wilson. *NISO TR01-1995 Environmental Guidelines for the Storage of Paper Records*. Bethesda, MD: National Information Standards Organization (NISO), 1995.

L. Selected World Wide Web Resources

American Institute for Conservation of Historic and Artistic Works: <<http://aic.stanford.edu>>

American Society of Heating, Refrigerating and Air-Conditioning Engineers: <<http://www.ashrae.org>>.

Canadian Conservation Institute: <<http://www.cci-icc.gc.ca/>>

Conservation OnLine (CoOL): <<http://palimpsest.stanford.edu/>>

The Getty Conservation Institute: <<http://www.getty.edu/conservation/institute>>.

Library of Congress: <<http://www.loc.gov/preserv/>>

National Archives and Records Administration: <<http://www.archives.gov>>

National Information Standards Organization: <<http://www.niso.org>>

National Park Service *Conserve O Gram* series:
<http://www.cr.nps.gov/museum/publications/conservoogram/cons_toc.html>

Society of American Archivists: <<http://www.archivists.org/>>

Archives and Manuscript Collections Separation Sheet

Document Type (map, newspaper clipping, photograph, etc.) Catalog/Accession Numbers

Document Description (Include collection name; dates; group organizational, personal, and place names; and topics [who, what, where, why, when, and how], etc.)

Item Originally Filed (Collection identifier: specific location, box #, folder #, drawer #, sequence in unit, etc.)

Item Now Filed (Specific location: room #, shelf #, box #, folder #, drawer #, sequence in unit, etc.)

Separated By:

Separation Date:

Figure J.6. Archival Separation Sheet (available in ANCS+)

RULES FOR HANDLING ARCHIVAL COLLECTIONS

1. Researchers (NPS and non-NPS staff) must be accompanied by museum staff at all times while in the collection research area.
2. Smoking, drinking, and eating are not allowed in any museum areas.
3. Briefcases, folders, coats, hats, umbrellas, backpacks, or other similar items are prohibited from the research area.
4. All researchers must remove necklaces, watches, bracelets, rings, and other jewelry.
5. All researchers must wear a pair of clean white cotton gloves at all times when handling collections.
6. Keep hands clean even when wearing gloves. All materials and surfaces in contact with the item must also be clean.
7. Handle papers as infrequently as possible.
8. **Only pencils** are allowed when working with collections.
9. Handle every item as though it is irreplaceable and the most valuable in the collection.
10. Researchers are limited to one folder at a time and must sign it out in the receipt book.
11. When finished working with a folder return it to the staff. Circulation to other patrons is prohibited.
12. Save all information that is associated with an item (e.g., folders, tags, labels, notes, etc.).
13. Only staff members are authorized to photocopy original materials. If you require duplication services, notify the staff.
14. If you have any questions or if any problems develop, notify the staff immediately.

Figure J.7. Example of Procedures for Handling NPS Archival Collections

Appendix K: Curatorial Care of Textile Objects

	<u>Page</u>
A. Overview	K:1
What information will I find in this appendix?.....	K:1
Why is it important to practice preventive conservation with textiles?	K:1
How do I learn about preventive conservation?	K:1
Where can I find the latest information on care of these types of materials?	K:2
B. The Nature of Textiles	K:2
What fibers are used to make textiles?	K:2
What are the characteristics of animal fibers?	K:3
What are the characteristics of plant fibers?	K:4
What are the characteristics of synthetic fibers?.....	K:5
What are the characteristics of metal threads?.....	K:5
C. The Fabrication of Textiles	K:5
What techniques are used to make textiles?.....	K:5
What kinds of finishes are used on textiles?	K:6
What other kinds of decorations are used on textiles?.....	K:8
D. Deterioration of Textiles	K:9
What agents of deterioration affect textiles?	K:9
How do textiles change over time?.....	K:9
How does the environment affect my collection?.....	K:10
What are the ideal temperature and RH ranges for textiles?	K:10
How does light affect textiles?	K:10
What kinds of pollution affect textiles?	K:11
How can I control pollution in my storage or display area?	K:11
What pests are attracted to textiles?	K:12
How can I protect textile collections from pests?	K:12
E. Proper Handling of Textiles	K:13
What do I need to consider before handling a textile?	K:13
How should I handle textile objects?	K:13
F. Storage Specifications	K:14
What do I need to know about storing textiles?.....	K:14
Where should I store my textiles?	K:15
How should I store my textiles?.....	K:15
G. Storing Flat Textiles	K:15
Which textiles are stored flat?	K:15
Which textiles are rolled for storage?	K:16
How do I roll a textile for storage?.....	K:16
Is it safe to roll quilts and counterpanes for storage?.....	K:17
H. Storing Costume Collections	K:17
How do I store dimensional textiles such as costume?.....	K:17
How do I know which method of storage is best for costume?	K:17
How do I properly support and protect a garment for hanging storage?.....	K:18
Why should I use dust covers for hanging costume?.....	K:19
How do I prepare an unconstructed garment for storage?.....	K:19

I. Storing Costume Accessories	K:21
What are costume accessories?	K:21
How do I store hats and bonnets?	K:22
How do I store shoes?	K:23
How do I store gloves and mittens?	K:24
How do I store bags and purses?	K:24
How do I store fans?	K:24
How do I store parasols and umbrellas?	K:26
J. General Considerations for Exhibition	K:26
How often should I rotate textiles in exhibitions?	K:26
What are special considerations for exhibiting textiles in open displays in historic houses?	K:27
What are special considerations for using rugs and carpets in historic house displays?	K:27
How should I treat original draperies, fabric wall coverings, and upholstery if they must be replaced by reproductions?	K:28
K. Exhibition of Flat Textiles	K:28
How should flat textiles be displayed?	K:28
What is the best way to construct padded supports for flat textiles?	K:28
What are appropriate supports for large textiles?	K:29
What is a hook and loop tape mount?	K:29
What if the textile is too long for the exhibition space?	K:30
What is a slant support?	K:30
What are the considerations for framing textiles?	K:31
What is a pressure mount?	K:32
When do I know if a pressure mount is the most appropriate display method?	K:32
L. Display of Historic Costumes	K:33
Where do I find appropriate mannequins to display costumes?	K:33
How do I display unconstructed garments?	K:34
M. Conservation Treatment	K:34
What NPS guidance is available to help me make decisions about conservation treatment?	K:34
What kinds of treatment and maintenance can be undertaken by park staff?	K:34
What kinds of treatment and maintenance should be undertaken only by a conservator?	K:34
What cleaning methods are used on textiles?	K:35
What should I know about vacuuming textiles?	K:35
What techniques are used to repair textiles?	K:36
What textile conservation terminology should I be familiar with when talking to a conservator?	K:37
N. Packing and Shipping Textile Objects	K:39
Are there special considerations for packing and shipping textile objects?	K:39
Are there special considerations for packing and shipping framed textiles?	K:39
Are there special considerations for packing and shipping costume accessories such as hats?	K:40
O. Emergency Procedures for Textile Objects	K:40
P. Glossary	K:41
Q. Bibliography	K:42
R. Additional Resources	K:44

List of Figures:

Figure K.1. Upright Loom	K:6
Figure K.2. Fan Folding a Textile	K:14
Figure K.3. Rolling Textiles for Storage	K:17
Figure K.4. Twill Tape Waist Supports	K:19
Figure K.5. Muslin "Sling" Support.....	K:20
Figure K.6. Padding the Folds of a Garment for Storage	K:21
Figure K.7. Hat Supports	K:22
Figure K.8. Bonnet on a Support.....	K:23
Figure K.9. Internal Support for Gloves and Mittens	K:24
Figure K.10. Support for a Fragile Fan.....	K:25
Figure K.11. Padding an Umbrella for Storage	K:26
Figure K.12. Hook and Loop Tape Mount	K:30
Figure K.13. Diagram of a Pressure Mount.....	K:32
Figure K.14. Polyethylene Foam Torso.....	K:34
Figure K.15. Proper Vacuuming Technique	K:36
Figure K.16. Interior of a Shipping Crate for Rolled Textiles	K:39

APPENDIX K: CURATORIAL CARE OF TEXTILES

A. Overview

1. *What information will I find in this appendix?*

This appendix discusses the physical characteristics of textiles and outlines guidelines for their long-term care and preservation. Many different kinds of objects are called textiles. They include:

- quilts and bed covers
- clothing
- tapestries and wall hangings
- rugs
- baskets and mats
- upholstery
- embroidered samplers and other household decorations

The main topics covered in this appendix are:

- textile materials, added materials, and their manufacture
- agents of deterioration
- handling, storage, display, and transportation of textiles
- working with a conservator when treatment is needed
- specific emergency procedures for textiles

2. *Why is it important to practice preventive conservation with textiles?*

The role of preventive conservation is to avoid, block, or minimize the **agents of deterioration**. This practice will decrease the need for costly and time-consuming conservation treatments.

Textile objects are among the most sensitive in museum collections. They are affected by light, require controlled relative humidity and temperature, and are susceptible to damage from dirt, mold, insects, pollutants and abrasion. A textile's rate of deterioration slows significantly with proper preventive care. Practicing preventive conservation also reduces the likelihood of accidents.

3. *How do I learn about preventive conservation?*

Read about the agents of deterioration that affect textiles so that you can create a preventive conservation plan. These agents are discussed in detail in Section D. Understanding how to protect your textiles from the agents of deterioration will lengthen the life of your textiles. See Chapter 3: Preservation: Getting Started, and Chapter 4: Museum Collections Environment, for a discussion on the agents of deterioration. Also refer to

4. *Where can I find the latest information on care of these types of materials?*

There are a variety of sources for up-to-date information about textiles:

- Read the NPS *Conserve O Gram* series.
 - Review the references in the bibliography. Especially note practical information found in *CCI Notes*, Section 13, Textiles and Fibres.
 - Look up the World Wide Web sources that are listed at the end of this appendix.
 - Consult a textile conservator.
 - Consult a curator or collections manager of a large textile collection.
-

B. The Nature of Textiles

The history of textiles goes back to the Stone Age. Long plant fibers were intertwined and made into baskets and mats. Basket making formed the basis of weaving technology. *Spinning*—twisting short fibers together to make a long thread—made it possible to use wool, cotton, and silk to make textiles.

Textiles are combinations of fibers, dyes, and finishes. Some textiles are decorated with thread (*embroidery*) and non-textile materials like shell, bone, and metal. It isn't possible to discuss all of these materials in this appendix. Consult the bibliography and list of resources at the end of this appendix for more detailed information

1. *What fibers are used to make textiles?*

Before the 20th century, natural fibers were used to make textiles. These fibers come from two main sources:

- animal fibers
 - hair
 - wool
 - silk
- plant fibers
 - stems
 - leaves
 - seeds

Twentieth century textiles may include synthetic fibers. These include fibers made from natural materials, mainly cellulose or proteins, and include:

- rayon

- cellulose acetate
- triacetate
- natural rubber

Other polymers are created in the laboratory. These include:

- nylon
- polyester
- polyurethanes

Some textiles include metal threads or yarns that are metal and fiber combinations. These can include any combination of metals and alloys, and backings or support materials.

2. *What are the characteristics of animal fibers?*

Animal fibers are made of chain-like molecules of proteins. The basic properties of the fibers are determined by the arrangement of these proteins. The arrangement of the proteins in wool explains why wool stretches and silk is more rigid.

Hairs are usually long and coarse and come from the outer coat of an animal. They are not always woven into fabric. Two examples of their use are:

- padding in furniture and clothing (horse hair)
- felt (made of rabbit hair rather than wool)

Examples of hair fibers that can be spun into yarn that is knitted or woven are:

- cashmere (goat hair)
- angora (rabbit hair or goat hair)
- mohair (rabbit hair)

Wool is the undercoat of sheep. Four factors determine the quality of wool yarn:

- the breed of animal
- the health of the animal
- the shearing process
- the cleaning process

Wool fibers have a “crimp” that lets the fibers cling together and makes them easy to spin. The elasticity and crimp of wool fibers varies by the breed of the sheep.

Silk is the long, continuous filament that comes from the cocoon of silkworms. The molecular structure is rigid. Therefore, silk does not stretch easily. Silk is sometimes treated with finishes and materials that add body and weight to the fabric. The effects of these materials are discussed in Section C.2 of this appendix.

3. *What are the characteristics of plant fibers?*

Plant fibers are composed mainly of cellulose molecules. The basic properties of the plant fibers are determined by the rigid structure of fairly regular chemical groups that attract water. The presence of water makes the fibers flexible and resistant to breaking.

Fibers can come from the stem, leaf, or seeds of plants. After harvesting, the fibers are separated, cleaned, and processed for spinning into thread. Each of these processes has an impact on the quality of the thread, and can influence the long-term preservation of a textile.

Flax is the most common stem (bast) fiber. Flax fibers are spun to make **linen** thread. Flax is soaked in water to loosen the fibers from the inner bark of the plant. This process, called *retting*, causes the fibers to decompose slightly. Further mechanical processing is needed to release the fibers from the bark. These fibers are hard, and not elastic. In processing, linen is:

- strong when wet
- resistant to heat
- difficult to bleach
- difficult to dye to concentrated colors

Leaf fibers are hard and strong. They are good materials for rope, cords, sandals, and baskets. Some examples that may be in collections are:

- sisal
- raffia
- abaca
- hennequin
- yucca

Cotton is the most common seed fiber. Cotton is nearly pure cellulose, and the fiber is relatively rigid. *Mercerization*, a common processing technique introduced in 1844 makes dyeing easier. It also adds softness and flexibility to cotton fabric. Other seed fibers are:

- coir (coconut fiber)

- kapok
4. *What are the characteristics of synthetic fibers?* Synthetic fibers have been designed to have a variety of performance characteristics. For example, polyester is very strong and resists wrinkling. You should not assume that synthetic fibers are sturdier than older fibers, or even contemporary textiles made of natural fibers. Synthetic fabrics have only been available in large quantities since the 1930s. We already know that some of these fabrics do not age well. Others have not been studied long enough to know the long-term effects of aging. Monitoring the condition of 20th century textiles in collections will help conservators develop a picture of long-term changes in characteristics and preservation concerns for synthetic fibers.
5. *What are the characteristics of metal threads?* Metallic threads can be woven into the structure of a fabric or used for embellishment. The metals are subject to oxidation (see Appendix O: Curatorial Care of Metal Objects). Metallic threads are produced in various forms including:
- gold metal layer on silver strip
 - gold, silver, and other metals and alloys cut into thin strips
 - small diameter metal wires of gold, silver, and copper alloys
 - thin strips of metal wound around a core of thread (usually silk or linen)
 - thin sheets of metal applied to leather or paper
 - metallic powders and pigments applied to Mylar® or other synthetic backings

C. The Fabrication of Textiles

- There are many techniques that result in cloth or cloth-like materials. Fabrication also includes the addition of color (dyes), finishes, and other decorations. It is the structure that is important in determining the characteristics of the cloth and is directly related to its ultimate use.
1. *What techniques are used to make textiles?* Some of the techniques used to make textiles are included here:
- Felting** is the process of using heat, water, and pressure to interlock loose fibers together. The best raw material is sheep wool because of its chemical structure and crimp. Lacquers and sizings can be used to stiffen the felt for particular uses. The same basic techniques for making wool felt are used today with synthetic fibers to produce synthetic felt.
- Spinning** is the process that converts short fibers into long threads or yarns. Loose fibers are pulled from a mass of prepared animal or plant fibers and twisted to create the yarn. This can be done by rolling the fibers down the spinner's thigh, by using a spindle, or by using a spinning wheel.
- Netting** is produced from a single, continuous strand using a tool called a shuttle. The thread is looped and may be knotted. Netting is the basis of

some lacemaking and tatting. Knitting and crocheting are other looped structures.

Lacemaking refers to a variety of techniques that involve the intricate twisting of fine threads to form a pattern. These include needlelace and bobbin lace that use combinations of twisted, crossed, plaited, and knotted structures.

Macramé is a knotting technique that uses more than one strand of yarn. This technique is used primarily for fringes and edgings.

Weaving is the making of cloth by interlacing threads of the warp and weft on a loom.

- *Warp* is the parallel yarn stretched on a loom (lengthwise).
- *Weft* is the transverse yarn interlacing with the warp in a pattern.



Figure K.1. Upright loom. (Weavers Mae and Sadie Curtis of Ganado at Hubbel Trading Post. Photograph by Fred Mang Jr. HUTR-23347)

Many structures and variations have been developed to produce fabric. The simplest structure of weaving (*plain weave*) is over-one, under-one interlacing of perpendicular warp and weft elements. The structure determines the characteristics of the fabric. Detailed discussions of weaving can be found in references listed in Section Q of this appendix.

2. *What kinds of finishes are used on textiles?*

Few textiles are simply processed fibers made into cloth. Dyes, lubricants, chemical compounds, mechanical treatments, sizing, water and stain repellents, mothproofing, and flameproofing are some of the treatments that prepare fabrics for use.

- *Dyes* are plant materials and various chemicals that add color to textiles. There are two general categories of dyes:

- natural (from plants, some insects, and some mollusks)
- synthetic (chemically produced colors developed in the 19th century)

Many natural dyes have good wash and light fastness. Early synthetic dyes are known for their harsh, bright colors, and poor wash and light fastness.

Some dyes have an affinity for textile fibers, but most require assistance to attach to the fibers. These chemicals, called *mordants*, are usually metallic salts applied to the cloth before dyeing begins. Mordants also can modify the dye color (different mordants used with the same dye material produce different colors).

Natural dyes mordanted with iron produce a black or brown-black color. These dyes deteriorate and destroy the fiber. Many printed cottons and tapestries used iron-mordanted yarns to outline designs. Often there are holes left in the fabric where these yarns used to be.

- *Cropping, napping, and shearing* of cloth raise the fibers to produce a soft, slightly piled fabric. *Rubbing, pressing, and glazing* give a smooth, lustrous surface. These mechanical processes are sometimes combined with oils, gums, starches, beeswax, varnishes, pitch, and gelatin. Egg white and water, or gum arabic was used on glazed woolens and linsey-woolsey blends in the 18th century. These finishes are fragile and can be damaged by handling and moisture.
- During weaving, oils, lubricants, and sizing are often used to keep yarns from tangling and to strengthen the warp against the friction of the loom. These materials are usually washed out by a laundry method called *scouring*. Scouring can range from gentle cleaning to processes using heat, pressure, and agitation.
- *Fulling* involves the use of lubricants, detergents, and other additives with water, heat, and agitation to produce felt. Felting causes the fibers to shrink and adds softness, body, and strength to the fabric. Very thorough felting produces strong, nearly waterproof fabrics that have been used for tents, coats, and shoes.
- Cotton threads and fabrics can be treated with a strongly alkaline chemical to add strength, durability, and luster to the fiber. This process of *mercerization* also reduces shrinking and makes the fiber more receptive to dyeing.
- During the 18th and 19th centuries, silk fabrics were sometimes treated with a variety of metallic salts to produce fuller, heavier textiles. These *weighted fabrics* were used for clothing, flags and banners, fringes, and tassels. When they were new, these fabrics had a fuller feel and drape than pure silk. However, weighted fabrics are not strong, and when aged, fracture and powder very easily. Washing and dry-cleaning easily damage weighted silks. They are very sensitive to the effects of light, moisture, and air pollution.

Finishing processes for synthetic and newer fabrics include:

- synthetic resins
- plasticizers
- mothproofing agents
- flame proofing chemicals
- emulsions used for soil, crease, and water repellency

Some of these processes are chemically active and their degradation products destructive to the textiles. Others are so recent that their long-term effects are not known.

Finishes are responsible for the performance and many of the characteristics of textiles. However, some of these treatments and chemicals enhance deterioration and limit the possibilities of conservation treatments.

3. *What other kinds of decorations are used on textiles?*

In addition to dyes, the texture of different weaving structures, and the effects of cutting and piecing fabrics together, textiles can be decorated with *embellishments* including:

- paint, pigments, and gilt
- braids and fringes
- added stitches
- metals
- beads
- fur and feathers

Embellishments may or may not be a structural component of the textile. Some embellishments, like beads, may be quite heavy. The areas where they are attached may be weak, and require extra support and care in handling.

- **Paint, pigment, and gilt** can be added to textiles to create surface designs. Printers' gums, waxes, starch, and adhesives may be present as well. These materials often are soluble in water. They also tend to stiffen the textile. Paints and gilt can crack when the textile is flexed or folded. Special care is needed for display, handling, and storage of painted textiles.
- **Fringes** may be a part of the structure of a textile or added after manufacture. In historic houses, fringes on rugs and carpets are subject to damage if they are in a public pathway.

- **Added stitches or embroidery** is a common form of decoration. All types of thread and yarn are used for embroidery. Embroidered textiles are most vulnerable to damage where the yarn or thread is stitched through the ground fabric. Cutting or tearing of the fabric is a result of the stress from tension on the yarn, or the interaction of the ground fabric and the thread together. For example, metallic thread is heavy and sometimes has sharp edges. It can cut or tear the textile.
- **Metals** in the form of metallic threads, metal strips, braids, and wires are used to decorate textiles. These decorations are often heavy and place strain on the underlying textile. A variety of metal combinations (alloys) have been used on textiles. The preservation concerns for these materials vary with the type of alloy (see Appendix O: Curatorial Care of Metal Objects).
- **Beads, buttons, and sequins** also can be used for decoration on textiles. These can be made of a wide variety of materials including glass, bone, stone, plastic, ceramic, and wood. All of these materials have different rates of deterioration and interaction with the textile. For example, early sequins were made of gelatin. In situations of high humidity these sequins become sticky and can dissolve.
- **Fur and feather** trims are particularly vulnerable to pest infestations and need to be monitored carefully.

D. Deterioration of Textiles

1. *What agents of deterioration affect textiles?*

Many factors contribute to a textile's deterioration. These *agents of deterioration* can occur naturally, or they can result from external forces. Avoiding agents of deterioration is the key role of *preventive conservation*. The agents that affect textile collections most are:

- light (visible and ultraviolet)
- temperature
- humidity
- pollution
- pests

Knowing the ideal settings for temperature, relative humidity, and visible light, and knowing how to filter UV radiation and pollution is essential for preserving your collection. An Integrated Pest Management (IPM) Program is essential to protect your collection from pests. For more information about these agents of deterioration, see Chapter 3: Preservation: Getting Started.

2. *How do textiles change over time?*

As all materials age, they slowly break down and constantly deteriorate. The basic deterioration of textiles is the gradual breaking down of long-chain fiber molecules into shorter chains. The result is brittleness. Other forms of natural deterioration are:

- *gradual loss of inherent moisture*: Natural fibers come from living sources with biological functions. As they age and the structure of the fiber changes, fibers become less elastic and resilient.
- *effects of impurities*: The presence of small amounts of metals, such as copper, can accelerate deterioration in the presence of bleaching agents, ozone, ultraviolet radiation, and moisture.
- *impact of manufacturing*: Iron mordants, oils and lubricants used to facilitate the weaving process, and bleaching are some of the manufacturing processes that can contribute to the deterioration of textiles.
- *inherent vice*: Sometimes methods of manufacture and the nature of materials cause deterioration that cannot be controlled and may not be treatable. The most striking example of inherent vice is the impact of the addition of certain metallic compounds to silks to add weight and drape to silk fabrics. These compounds bond to the silk fiber and cause their eventual splitting and powdering. Another example is the interaction of some metal threads and decorations with textiles. The natural deterioration of wool accelerates deterioration of silver metallic threads causing tarnish. The tarnish can then stain the wool.
- *oxidation*: Fabrics are naturally degraded by the presence of oxygen. The result is an overall brownish discoloration on white or natural-colored textiles. When treated with water, some of these oxidation products are dissolved. However, the oxidation process begins again immediately.

3. *How does the environment affect my collection?*

Temperature, relative humidity, light, and pollution directly affect the rate at which a textile ages. Storing and displaying textiles in areas where temperature is too high and RH is too high or low will increase deterioration rates and promote pest activity. Constant or large fluctuations in temperature and RH are harmful, too. Textile fibers are *hygroscopic*—they readily take up and lose moisture. Fluctuations of relative humidity and temperature cause textiles to take up or lose moisture. These fluctuations cause dimensional change and mechanical stress that can lead to breakage and structural damage of weak yarns. Natural and artificial lighting cause textile dyes to fade. UV radiation causes fading to happen quickly and fibers to become brittle. Pollution, including dirt, settles in the structure of a textile, causing its character to change completely. Pollutants also affect dyes, finishes, and many embellishments.

4. *What are the ideal temperature and RH ranges for textiles?*

Store textiles at temperatures between 65° and 75° F and relative humidity as close to 50% as possible. Low temperatures are not a problem for textiles and may help slow down the rate of deterioration for textiles that are damaged by weighting. High temperatures can embrittle textiles, and together with high relative humidity, promote biological activity. Low relative humidity (under 35%) can embrittle textiles. Avoid temperature and relative humidity fluctuations.

5. *How does light affect textiles?*

Light causes textile dyes to fade and undyed textiles to bleach or darken. Light can also be a catalyst for deterioration of weighted silks. Light damage is cumulative and irreversible. The amount of light damage

depends on the type of light (ultraviolet and/or visible), intensity of the light, and duration of exposure. Evaluating your collection's lighting conditions and making appropriate adjustments can prolong the life of your collection. Review the natural and artificial light sources in your storage and display areas. Use monitoring equipment to identify levels of UV radiation and illuminance (levels of visible light are measured in "lux").

Reduce your collection's exposure to light by storing and displaying textiles in rooms without windows. (Clear UV-absorbing films will reduce UV levels, but will not reduce illuminance.) Cover all windows with drapes or blinds to further protect textiles. Avoid storing and displaying textiles in rooms with doors that open to the outside.

The maximum illuminance recommended for textiles is 50 lux. All UV light should be filtered. Consider ways to limit the total light exposure, such as automatic dimmer switches, or simply turning out lights when visitors are not present.

6. *What kinds of pollution affect textiles?*

Outdoor pollutants, such as dust and pollen, can easily be brought into a museum through open doors and windows. Industrial emissions as well as natural processes of erosion create pollutants. Cleaning products, asbestos fibers, building materials, paint, carpeting, and other indoor materials can generate pollution from within a museum. Cigarette, cigar, and pipe smoke are also harmful forms of pollution.

Dirt disfigures, dulls, and stains textiles. Dirt and dust also contain a high proportion of silica. The sharp surfaces of silica can cut and abrade textile fibers, especially when the fibers expand and contract in response to changes in RH.

Sulfur dioxide bleaches, discolors, and embrittles textiles. Hydrogen sulfide in the presence of moisture darkens lead pigments, tarnishes metals, and reacts with finishes and some embellishments.

Formaldehyde in paints, varnishes, wood products, and carpeting damage some dyes.

Tar and particulates from tobacco products stain textiles and are difficult to remove.

7. *How can I control pollution in my storage or display area?*

Follow these practices:

- Keep doors, windows, and outside vents closed whenever possible.
- Never allow smoking or fireplace fires in the building.
- Choose new building materials, paints, and carpeting that do not emit harmful gasses.
- Don't use custodial cleaners that emit harmful gasses (for example ammonia).
- Use appropriate particulate and gaseous pollution filters in your HVAC system.

- Store textiles in closed cabinets with appropriate gaskets.
- Keep particularly vulnerable objects in sealed display cases. Make sure these cases meet the recommendations in *MH-III*, Chapter 7: Using Museum Collections in Exhibits, and NPS *Exhibit Conservation Guidelines*.

For more information on controlling pollutants, see Chapter 4: Museum Collections Environment.

8. *What pests are attracted to textiles?*

Textile fibers are an excellent source of food for microbes and insects. Sizing, starch, gelatin, binding media for pigments, soils, and stains also are attractive to pests.

- Case bearer and webbing clothes moths are attracted to high protein material including wool, silk, hair, fur, feathers, and skins. The female moth lays eggs within the weave structure of the textile. The eggs hatch and the larvae feed on the textile material. Larvae take on the color of the materials they consume, making them difficult to see. Moths channel through the textile making holes, or “graze” on the surface thinning the yarns and weakening the textile structure.
- Silverfish, cockroaches, termites, and woodworms eat cellulose and graze on parchment, leather, paper, fabrics, glues, and painted decorations.
- Woodworms, termites, and carpet beetles can be found in furniture and associated furnishing fabrics, upholstery, and the inner structure of upholstery materials. Carpet beetles also attack silk and wool textiles.
- Mold and mildew grow in warm, damp locations. Irreversible brown stains are caused by enzyme attacks from the digestive processes of these organisms.

9. *How can I protect textile collections from pests?*

Follow these practices:

- Develop and implement a regular housekeeping plan. Pests are attracted to soils and a dirty environment.
- Develop and implement an IPM plan. Regular inspection and recording sightings of insects or insect debris is crucial to any pest management system. All park staff can be integral to systematic preventive conservation through identification of problem objects or areas.
- Prevent the initial entrance of insects into the collections. Flowers, plants, and potting soil are good sources for introducing an insect problem to the site. These materials should not be permitted in buildings that house collections.
- Isolate newly acquired collection objects from the rest of the collection. Determine if any insects are present and make sure they have been eradicated before new collections are integrated into storage or exhibition areas.

- If an infestation is suspected or located, isolate affected objects from the rest of the collection. Examine the surrounding area to locate possible sources of infestation (such as beneath floorboards, inside a cushion, or in bird and rodent nests under eaves and between walls).
- Immediately consult with a conservator and your park or regional IPM coordinator to identify appropriate treatments.

For more information about IPM and pest infestations, see Chapter 5: Biological Infestations

Controlling pests and the environment—light, temperature, relative humidity and air pollution—are keys to the long-term preservation of textiles.

E. Proper Handling of Textiles

1. *What do I need to consider before handling a textile?*

Following are a few guidelines:

- Keep hands away from textiles unless handling is absolutely necessary. The body gives off acids and oils through its pores that can damage textiles. Wash hands often and use white cotton gloves whenever possible.
- If the textile is fragile, carry it flat on a support.
- Make sure there is a clean surface of adequate size available before you move a textile from one place to another.
- Avoid carrying all but the smallest textiles by yourself. Get another person to help when you are transporting large, heavy textiles. Use a well-padded cart in good condition to transport boxed and smaller items.
- Remove jewelry, badges, belt buckles, and watches that might catch on and tear textiles, especially during installation and preparation of textiles for storage.
- Use clean, padded surfaces when working with textile collections. Keep tools, inks, and other writing materials away from the work area. Use only pencil when working around textiles.
- Avoid placing textiles one on top of another. When stacking them is absolutely necessary, interleave textiles with unbuffered, acid-free tissue paper, and be aware of the weight of one textile on another.

2. *How should I handle textile objects?*

Unlike a ceramic or wooden sculpture, textiles are not rigid, and need to be supported when they are lifted. Lack of support can result in stretching and tearing of the fabric.

- Roll a flat textile around an archival tube for transport or storage.

- Textiles with fragile surfaces, beads, heavy embroidery, or other surface attachments can be fan-folded and supported on a muslin-covered, corrugated archival board or in an archival cardboard tray (see Figure K.2).
- Place a muslin-covered, corrugated archival board or archival cardboard tray under fragile textiles and fragments for support.
- Large, heavy textiles (such as carpets and tapestries) require two handlers even if rolled on a support tube.
- Pad the interior of costumes with crumpled unbuffered, acid-free tissue and transport them in archival textile boxes.
- Fold pieces as little as possible. Textiles tend to break along fold-lines in time. Pad folds with crumpled unbuffered, acid-free tissue paper.
- Transport supported textiles on a well-padded cart.

Always use a support or container when moving textiles.



Figure K.2. Fan folding a textile into archival tray

F. Storage Specifications

1. *What do I need to know about storing textiles?*

Improper storing of textiles can be a catalyst for deterioration. Consider the elements that affect a textile in storage.

- Control the agents of deterioration.
- Choose appropriate storage space and equipment. Use only archival materials (tubes, unbuffered tissue, cardboard) in contact with textile objects (see Chapter 7: Museum Collections Storage).
- Ensure that proper security and fire detection and suppression equipment is installed and maintained (see Chapter 9: Security and Fire Protection).

2. *Where should I store my textiles?*

Your collection size is an important consideration when you determine where to store your textiles. If you have many textiles, consider creating a dedicated storage room. If you have only a few textiles in your collection, dedicate a space or cabinet in your museum storage area for your textiles. As much as possible, store textiles in properly gasketed closed cabinetry. Closed cabinets provide extra protection from pests, as well as potential water damage that might result from a flood or fire. Never store textiles:

- in attics or basements
- against exterior walls
- near furnaces or heating/air conditioning vents
- in spaces below water pipes

3. *How should I store my textiles?*

The structure of a textile, its condition, and size determine the best storage method. In general, you will choose from the following storage methods:

- archival rolling tubes
- flat-file cabinets
- archival boxes
- costume wardrobe cabinets
- shelving units
- specialized containers

G. Storing Flat Textiles

1. *Which textiles are stored flat?*

Flat storage is ideal for most textiles because it provides complete support for the object. Small textiles (for example, samplers and some household linens), fragments, and particularly fragile textiles should be stored flat. Flat storage is impractical for most large items like carpets and tapestries. However, permanently gathered or pleated curtains should be stored flat in archival costume boxes or drawers using padding techniques described for costume (see H.5 below).

Shallow drawers, like flat file cabinets, are well suited to flat textile storage. Sturdy textiles can be stored between sheets of unbuffered archival tissue. Avoid stacking textiles as much as possible. More delicate textiles may require a support to protect the fabric as it is lifted from the drawer. A simple support can be constructed by covering a piece of corrugated archival cardboard with washed muslin. Line drawers with closed cell polyethylene foam such as Volara®.

Very fragile small textiles (for example, brittle archeological textiles) may require additional protection. A modified print mat provides space economy as well as protection for handling and storage. (see *MH-1*,

Appendix I, Figure I.8 Construction of a Portfolio Mount for Archeological Textile Fragments or *Conserve O Gram* 16/3 “A Simple Storage Mat for Textile Fragments”).

Other textiles that are best stored flat include:

- velvets, and other textiles with a pile structure that could be crushed if rolled or folded
- textiles with a fragile surface, such as gilt or paint
- textiles that are particularly brittle or stiff
- textiles with a very uneven surface, such as strongly raised embroidery
- textiles with heavy beading or metallic embroidery
- costumes cut on the bias

2. *Which textiles are rolled for storage?*

Flat textiles (for example, Navajo rugs, tablecloths, and tapestries) are usually rolled for storage because they are too large to handle safely if stored flat. Archival rolling tubes are available in 2” and 3” diameters. Choose a tube with a diameter suitable for the object being stored. The 2” diameter tube is ideal for thin textiles, for example, a length of lace. The larger diameter tube is suitable for carpets or coverlets. The outside of a tube can be covered with bubble wrap to create an even larger diameter tube for oversized, fragile textiles. The tube should be at least 6” longer than the width of the textile.

3. *How do I roll a textile for storage?*

Work on a clean, well-padded surface (mattress pads make good covers for worktables). Lay the textile flat, gently smoothing wrinkles. Most textiles should be rolled face in so that the design will be face up when the textile is unrolled. Textiles with raised surfaces should be rolled face out. If the textile has a lining, roll lining side in. When a double thickness of fabric is rolled, the inner layer tends to wrinkle. It is preferable to create wrinkles on the lining rather than on the face of the textile.

- Roll unbuffered archival tissue once around the tube to provide a “leader” to guide the textile onto the tube (see Figure K.3). The tissue should extend slightly beyond the width of the textile but not beyond the edge of the tube.
- Interleave unbuffered archival tissue as you roll to protect the face of the textile.
- Two or more people should roll large pieces to maintain a uniform tension.
- To protect the roll from dust, cover it with washed muslin tied in place with cotton twill tape. Attach catalog and other identifying numbers to the dust cover to prevent unnecessary unrolling.
- Long or uneven fringes are difficult to roll. Make a “fringe folder” from a piece of unbuffered archival tissue to enclose fringes and

simplify the rolling process.

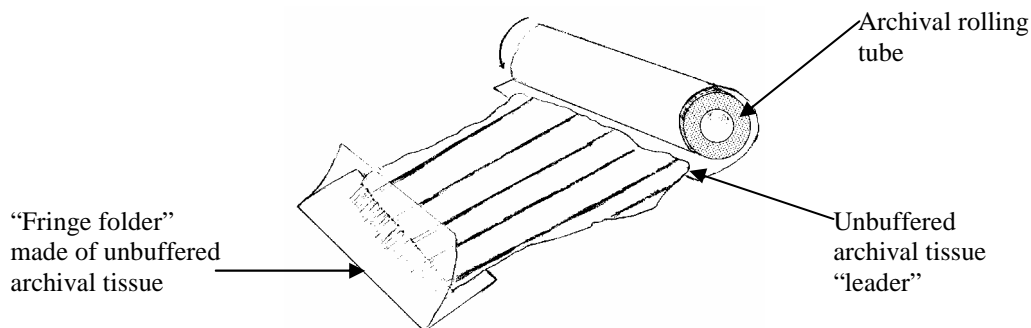

Figure K.3. Technique for rolling flat textiles for storage

4. *Is it safe to roll quilts and counterpanes for storage?*

Quilts and counterpanes are usually three layers thick (face, padding, lining). If the fabrics are in stable condition and there is no weakness in the stitching, they can be safely rolled. As with lined textiles, roll quilts and counterpanes **face out** with the lining or backing side in.

Many Victorian “crazy quilts” are made of weighted silk and velvet fabrics. These fabrics split and become powdery as they deteriorate. They should **not** be rolled for storage. Fragile over-sized textiles, like crazy quilts, can be fan-folded on a support board and stored in a drawer. Alternatively, these textiles can be stored, with minimal folding, in an archival costume box using the same general techniques described in H.5 below.

H. Storing Costume Collections

1. *How do I store dimensional textiles such as costume?*

Costume objects are stored in one of two ways depending on condition:

- hanging in a wardrobe cabinet
- folded in an archival textile or costume box

2. *How do I know which method of storage is best for costume?*

In general, fitted, constructed garments in good condition can be hung for storage (for example, dresses, bodices, coats, and jackets coming from the European clothing tradition). Museum storage hardware companies manufacture both costume wardrobe cabinets and clothing racks for this purpose. This type of storage is the most economical for costume storage because it takes less space than flat storage.

Ask the following questions to evaluate the best form of storage for costume items:

- Are shoulder seams strong and intact?
- Is the fabric in the hanging area free of splits, holes, or other weakness?
- Can the waistline support itself without causing strain at the shoulders or waist?
- If the waistline can't support itself, can it be adequately supported with the addition of waist tapes? (See Question 3 and Figure K.4)

If the answer to all of these questions is “yes,” proceed to prepare the costume for hanging storage. If “no,” store the costume flat following the instructions in Question 5 below.

Unconstructed clothing is better stored flat, or with minimal folding, in an archival box (for example, kimonos, and many forms of ethnic dress that use the rectangular shape of fabric yardage in clothing construction). The following are also best stored flat in boxes or drawers:

- fragile costumes and garments with weakness at the shoulders
- men's breeches or pants
- dresses with fragile waistlines
- skirts
- costumes with heavy beading
- bias cut garments (for example, some couture costume and “flapper” dresses from the early 20th century)

3. *How do I properly support and protect a garment for hanging storage?*

The goal of good hanging storage is to provide sufficient support to reduce strain across the shoulders and other vulnerable areas (for example, the waistline of a dress with a heavy skirt). See *Conserve O Gram* 4/5, Storage Techniques for Hanging Garments: Padded Hangers, and 4/15, Storage Techniques for Hanging Garments: Dust Covers.

Choose or modify a wooden hanger to provide the base for a hanging support. The ends of the hanger should reach into the sleeve, just beyond the sleeve seam.

- Reduce potential strain from heavy, bulky, or awkward garments by providing waist supports.
- Use a dust cover to protect each costume from dust, light, and abrasion from contact with other garments.
- Label dust covers with catalog and other identifying numbers to avoid unnecessary handling of the garment.
- Hang costumes in closed, properly gasketed cabinets, leaving at least 1.5 inches of space between each object. If costumes must be stored on open racks, always use **closed** dust covers.



Figure K.4. Twill tape waist supports (illustration by Jian Wu, reproduced with permission of Abrams Publishers)

4. *Why should I use dust covers for hanging costume?*

Dust covers do more than protect a garment from dust and light. For example dust covers:

- protect the textiles from oils and acids from your hands
- prevent the transfer of fugitive dyes from one object to another
- prevent metallic embroidery and other attachments (for example braid and buttons on military uniforms) from catching on and tearing other garments

- prevent abrasion of adjacent objects as costume items are moved in and out of storage cabinets

5. *How do I prepare an unconstructed garment for storage?*

Unconstructed garments (such as Pueblo and Hopi kilts and dresses) are stored flat in archival boxes or in drawers. The goal of good flat storage for these garments is to:

- use as few folds as possible
- provide adequate padding in folds to prevent creasing
- provide adequate support to safely lift the garment from the box or drawer

A muslin “sling” is useful to lift a garment from a box (see Figure K.5). A muslin-covered corrugated board, with or without a muslin wrapper, is useful to lift a garment from a drawer.



Figure K.5. Muslin “sling.” Muslin can be placed under and folded over a garment to be used as a “sling” to lift and move the item. The “sling” also acts as a dust cover to protect the textile from handling.

To prepare an unconstructed garment for storage using a support board

- Lay the garment flat on a clean, padded surface.
- Cut corrugated board slightly larger than the size of the folded garment and slightly smaller than the interior dimensions of the drawer.
- Cut one piece of washed and ironed muslin the same length as the support board and three times the width, and one piece the exact length and width of the support board.
- Clean-finish the edges of both muslin pieces with pinking shears or a zigzag machine stitch.
- Attach the smaller piece of muslin to the support board with four small tabs of archival double-sided tape at the corners.

- Center the larger piece of muslin below the board and secure it to the board with strips of double-sided archival tape (1/3 of the muslin will extend beyond the edge of the support board on either side).
- Lay the garment on the support board with the neck or top edge just below the edge of the board, and the other three sides hanging over the edges.
- Place padding (for example, crumpled unbuffered archival tissue or batting “sausages”) in the garment seams.
- Using as few folds as possible, placing padding in each fold, fit the garment onto the backing board.
- Drape the muslin extensions over the folded garment and tie closed with cotton twill tape.
- Label the cover with catalog or other identifying numbers to prevent unnecessary unwrapping.

To prepare storage without a support board:

- Cut one piece of muslin the same length as the storage box and three times its width.
- Center the garment on the muslin and fold as above, making sure to keep the final size of the folded garment slightly smaller than the box interior.
- Drape the muslin extensions over the folded garment and tie closed with cotton twill tape.
- Using the muslin cover for lifting, lower the folded, wrapped costume into the costume box.
- Label the cover and the outside of the box with catalog or other identifying numbers to prevent unnecessary unwrapping.

Use two people to transport costumes on support boards and to lift costumes from drawers and storage boxes.



Figure K.6. Rolled or crumpled archival tissue pads the folds of the dress. To keep the garment from shifting as the box is transported, additional rolls of tissue fill the empty space in the box.

I. Storing Costume Accessories

1. *What are costume accessories?*

There are many objects besides clothing included in costume collections. These objects are often composed of several materials, including wood, leather, bone, ivory, metal, paper, fur, and feathers. For example, costume accessories include:

- hats and bonnets
- shoes
- gloves
- purses
- fans
- umbrellas and parasols

Costume accessories are composite objects made of several materials. The care of these objects requires attention to the specific needs of those various materials. Refer to the *Conserve O Gram* series for information on the care of individual materials. See also Appendix N: Curatorial Care of Wooden Objects, Appendix O: Curatorial Care of Metal Objects, and Appendix S: Curatorial Care of Leather and Skin Objects. You will need to provide special storage supports for most costume accessories.

2. *How do I store hats and bonnets?*

Construct padded polyethylene foam supports for hats and bonnets to maintain their shape (Figure K.7). The support should raise the brim slightly off the shelf to prevent distortion. Hats with weak brims will require a full support in the crown and under the brim. Hats with weak

crowns should have a soft insert (rather than rigid polyethylene foam).

- Store hats in closed, gasketed cabinetry.
- Store hats separately from original hat boxes.
- Construct a drop-sided box to facilitate handling if a hat needs to be stored in a box for its protection (Figure K.8).
- Do not stack hats.
- Protect bows, feathers and other appendages from abrasion and crushing by padding with unbuffered archival tissue.



Figure K.7. A fabric-covered polyethylene foam support has been created to support the crown of this Civil War cap. A thin piece of Plexiglas® supports the bill.

Figure K.8. Leghorn bonnet on a support inside a drop-front archival storage box.



CAUTION: Hats made of fur, feathers, and pieces of taxidermied birds and animals may contain pesticide residues including arsenic. Test all bird and mammal skins collected and prepared prior to the mid-1980s (see *Conserve O Gram 2/3*, Arsenic Health and Safety Update). If arsenic or another pesticide is suspected, use the following handling precautions:

- Do not touch specimens with bare skin. Wear plastic gloves and a protective smock or lab coat. Wear a dust mask rated for toxic dust. If possible, handle the object or specimen by a container or a mount.
- Always wash hands after working with specimens. Discard gloves. Keep the protective smock or lab coat clean. Do not take protective clothing home to wash—especially if you live with small children or elderly people.
- Obtain a Material Safety Data Sheet (MSDS) on arsenic and other pesticides and keep in the park's curatorial workspace/office. Consult the MSDS for specific information.
- Label museum cabinets or storage spaces that house specimens contaminated with pesticides with warning signs. Also label individual specimens that have been tested. Prepare and post a written set of instructions for handling specimens contaminated with arsenic and other poisons.

Consult Chapter 11: Curatorial Health and Safety, for more information.

3. *How do I store shoes?*

Shoes should be padded for support on display and in storage. Supports should fill the entire shoe all the way to the back of the heel. Make a “sock” of cotton stockinet to fit the interior of the shoe. Stuff the sock with polyester batting from the toe to the arch. Insert a shaped piece of rigid polyethylene foam from the arch to the heel, and stitch the sock closed. The sock should provide uniform, solid support without stuffing the shoe tightly.

- Support the entire shoe. Do not handle shoes by the heel alone.
- Provide adequate support to the ankle and leg sections of boots by constructing a second “sock” filled with polyester batting to fill that

area. If the ankle is weak, the support can be constructed of shaped polyethylene foam.

- For the protection of staff as well as the shoes, do not store shoes and boots on upper shelves or movable shelves. It is best to contain shoes and boots within shallow boxes for storage.
- Store shoes and boots in closed, gasketed cabinetry. If this is not possible, provide dust covers of washed muslin for each pair. Label the dust cover with catalog and other identifying numbers to prevent unnecessary handling.

4. *How do I store gloves and mittens?*

Gloves and mittens may require internal supports to prevent crushing or creasing. Do not force a support into the fingers of the glove. A simple support can be cut from 2-ply archival matboard. Be sure to sand or burnish the cut edges of the board so that there are no rough spots. If more padding is required, pad the matboard with polyester fleece Pellon and finish with a layer of cotton stockinet (Figure K.9).



Figure K.9. Internal support for gloves and mittens. Internal supports should be smooth and slightly smaller than the object. Do not over pad the interior of a dimensional textile.

5. *How do I store bags and purses?*

Bags and purses may need to be gently stuffed with unbuffered archival tissue to maintain their shape. The best way to prevent damage to handles, chains, and clasps, is to wrap them with tissue, or create cavity packs in storage drawers. Cavity packing offers the additional benefit of isolating the metals and other materials of the handles and chains from the textile.

6. *How do I store fans?*

Fans should be stored closed if they are in good condition. Storing fans open may cause distortions that will prevent their being closed in the future. However, if the paper or fabric body of the fan is cracked or split, repeated opening and closing will cause damage. In this case, the fan should be stored open on a graded support (see Figure K.10).

- Provide support for tassels attached to the heel of the fan.
- Store fans separately from original cases or boxes.

Step 1: Cut a fan-shaped support board from 4-ply archival mat board or archival corrugated board at least 1" larger in dimension than the fan.



Step 2: Cut wedge-shaped pieces of polyester batting, layering them on the support board to match the profile of the opened fan.



Step 3: A small roll of batting will be necessary to support the uppermost fan sticks.



Step 4: Cover the padded support with washed cotton fabric, stitching the cover together in the back. Make two parallel cuts through the mount on both sides and thread twill tape ties through to the front. Secure the fan sticks with the twill tape ties.



Figure K.10. Padded support for a fragile fan.

7. *How do I store parasols and umbrellas?*

Parasols and umbrellas are composite objects made of combinations of fabric, paper, bone, wood, and ivory. The condition of individual objects will determine the best storage method.

- Check for metal corrosion and sharp edges. These will need to be wrapped or padded to prevent damage to the rest of the object.
- Store parasols and umbrellas slightly furled, padding the folds with unbuffered archival tissue that is rolled into narrow cones (Figure K.11).
- Do not open a parasol or umbrella completely unless it is absolutely necessary.
- If the parasol or umbrella fabric is relatively sturdy, wrap the padded object in muslin secured with twill-tape ties before laying it in a drawer.
- If the parasol or umbrella fabric is weighted silk or another fragile material, wrap the padded object in unbuffered archival tissue before securing it in a muslin wrapper.
- Label the muslin wrapper with catalog and other identifying numbers to prevent unnecessary handling.



Figure K.11. Pad the folds of an umbrella with cone-shaped rolls of archival tissue.

J. General Considerations for Exhibition

Textiles are fragile. They are subject to deterioration by improper levels of temperature and RH, UV and visible light, pests, pollutants, and improper handling. Like other sensitive materials, you should periodically change textiles in exhibitions.

1. *How often should I rotate textiles in exhibitions?*

Rare or fragile textiles should remain on display for periods of three to six months. Sturdy textiles, properly mounted and displayed in optimum exhibition conditions may remain on display for six to nine months.

Long-term and permanent exhibitions should be designed to allow for rotation of textile objects at three, six, or nine month intervals, depending on the condition of the item.

2. *What are special considerations for exhibiting textiles in open displays in historic houses?*

Location of objects within the display is important. Check the location of lighting fixtures, air vents and intakes, and entry and exit locations for visitors. Avoid placing textiles in these locations in the display. Use these guidelines:

- Place furniture cups or small discs of archival corrugated cardboard under furniture legs and casters when furniture is placed on historic carpets or floor coverings.
- Separate textiles from polished wood and other surfaces with a sheet of thin Mylar® or unbuffered archival tissue.
- Use barriers to prevent visitors from sitting on furniture or entering rooms.

Ropes and chair cords are not always completely effective in preventing visitors from touching fragile objects or sitting on furniture. Place delicate objects beyond reach. Construct chair cords so that they will give way if a visitor sits on the chair. If the cord is tight, it may stress the furniture joints and cause them to break.

3. *What are special considerations for using rugs and carpets in historic house displays?*

Avoid using valuable historic carpets and rugs on the floor unless they are where the public will not walk on them. For all rugs and carpets used on the floor, use the following guidance:

- Appropriate rug pads should be used. Some synthetic padding (Dacron polyester) has a non-skid surface that is placed against the floor to prevent the rug from slipping. Avoid rubber non-skid pads, jute, and horsehair.
- Remove shoes, or cover shoes with operating room “booties” when performing maintenance activities on and around historic carpets.
- Do not use vacuums with beater attachments on historic rugs. All parks should have a vacuum that is reserved for collection objects rather than routine maintenance of the building. Use that vacuum and control the suction. The plastic wood-floor attachment is usually adequate for vacuuming rugs that are not walked on regularly. Vacuum in the direction of the pile.
- Vacuum the back of the rug, padding, and floor underneath at least once a year.
- Monitor pest traps for carpet beetle and moth evidence regularly, and act quickly if an infestation is suspected.

- If visitor traffic must be directed across a carpet, use a runner to designate the walkway. A runner made from synthetic carpet is the best choice. If clear plastic runners must be used, choose one that does not have pointed tabs on the back that are meant to pierce the carpet underneath to hold the runner in place.
- Avoid traffic across the fragile fringe of any carpet.
- Consider using a reproduction carpet.

4. *How should I treat original draperies, fabric wall coverings, and upholstery if they must be replaced by reproductions?*

It is important to keep representative samples of all components of furnishing fabrics as part of the collection. This will include fringe, gimp, decorative tacks, and linings. If samples of materials like horsehair padding are kept, be sure to enclose them in polyethylene zip closure bags to prevent insect infestation. The original material, its location, method of attachment, and any other data should be thoroughly documented in writing and with photographs before it is replaced. Consult with historic furnishing experts before any disassembling or decisions on replacement are taken.

K. Exhibition of Flat Textiles

1. *How should flat textiles be displayed?*

Carefully assess the condition of an object before deciding upon a display technique. If there is any question, consult with a textile conservator for guidance. Use the least interventive method of installing textiles in exhibition wherever possible. Use minimal stitching, or avoid stitching if possible. Pinning is sometimes an option. Use only rustproof entomological pins to secure textiles to supports.

Preparing a stitched textile mount requires skill and care. In most cases, a textile conservator should prepare a stitched

Small and fragile textiles can be placed flat or on a slanted support in an exhibition case.

- Display cases must be constructed of appropriate materials (see the *NPS Exhibit Conservation Guidelines* CD available from the Division of Conservation at Harpers Ferry).
- Avoid folding textiles wherever possible.
- Minimize handling during installation and de-installation by using rigid, padded supports (see Question 2. below).

2. *What is the best way to construct padded supports for flat textiles?*

Choose a lightweight but sturdy material like archival corrugated cardboard, archival honeycomb panels, or corrugated polyethylene sheets (Core-X®) for the support. The board should be equal to or slightly larger than the size of the textile.

- Pad the board with a thin layer of polyester quilt batting or Pellon fleece.

- Wrap washed cotton fabric around the padding and board and secure the fabric to the back of the mount with double-sided archival tape or polyethylene hot-melt adhesive.
- Lay the textile on the fabric surface. Use a few rustproof entomological pins to secure the textile to a slanted support. Try to slide the pins between, rather than through, yarns.
- Avoid using pins if a textile is brittle or fragile. Instead, place the textile on its support flat in the exhibition case.

3. *What are appropriate supports for large textiles?*

Consult with a conservator before attempting to mount large textiles for hanging. A fine silk hanging will have different requirements than a heavy wool tapestry.

- A textile should be hung in the warp direction whenever possible. Do not hang along the bias.
- The mount should distribute the weight of the textile without causing stress to any particular point.
- Roll, rather than fold, excess length for oversized textiles.
- There are several display options for large textiles, including hook and loop tape, draping, rolling, and large slant supports.

4. *What is a hook and loop tape mount?*

Hook and loop tape (also known as VELCRO®) is an appropriate hanging material for large textiles in sturdy condition. Do not use the adhesive-backed tapes. The soft (loop) tape should be machine-sewn to a strip of upholstery webbing, and the webbing hand-sewn to the back of the textile. The stiff, hook tape is attached with rustproof staples to a sealed wooden batten. The wooden batten is installed on the wall, and the two tapes pressed together (see Figure K.12). Hook and loop tapes are sometimes used on the sides of textiles to stabilize areas that are uneven. The bottom of large textiles should not be fastened down to allow the textile to expand and contract in response to small environmental changes.

Figure K.12. Installation of a hook and loop tape mount (drawing by Jian Wu courtesy of Abrams Publishers).

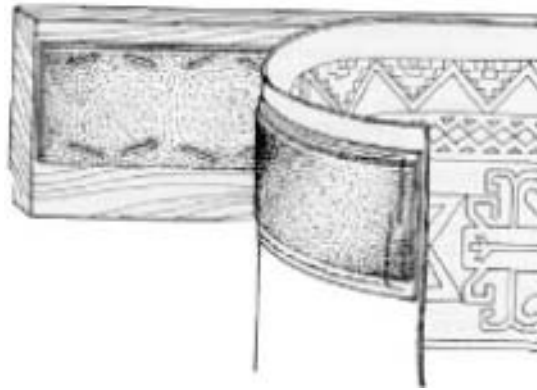

5. *What if the textile is too long for the exhibition space?*

Hang large textiles at least twelve inches above the floor to prevent damage by visitors and cleaning equipment. If a textile is too long for the space, consider the following options:

- Hang the upper edge of the textile with hook and loop tape. Allow the extra length to drape onto a platform in front of the textile. Separate the textile from the platform with a sheet of Mylar®.
- Cover an archival rolling tube with washed cotton fabric and roll the top edge of the textile object onto the tube. Mount the tube on the wall with brackets.
- Drape the textile over a fabric-covered archival rolling tube and install the tube on the wall with brackets. This method is safe for many textiles, but is not very secure against theft. If you use this mounting technique, provide a barrier or enclose the textile in an exhibition case.

6. *What is a slant support?*

Large textiles that are too fragile to be hung by the top edge alone can be displayed flat on a platform, or on a slanted, fabric-covered support. Use the following materials to construct large slanted supports:

- Rigid paper honeycomb panels are among the best materials to use in constructing large supports. Use aluminum channel frames to construct a support with several panels.
- Some woods and plywood can be used to construct a support if properly finished (see Technical Notes 5: Exhibit Case Construction Materials from *NPS Exhibit Conservation Guidelines* available from the Division of Conservation, Harpers Ferry).
 - Choose well-seasoned, air-dried poplar, exterior grade plywood or high or medium-density boards using formaldehyde-free adhesive.

- Finish these boards with several coats of moisture-borne polyurethane varnish and allow to dry completely.

NOTE: Not all moisture-borne polyurethanes are safe for use. Also, formulations can change without notice. Test the varnish prior to use to guarantee its acceptability.

- Place a layer of polyester quilt batting or Pellon® on the finished wood.
- Cover the board with washed cotton fabric. Fabric can be secured at the back of wooden boards with rustproof staples.
- Attach the textile to the display board with hook and loop tape mounts. If the textile is fragmentary or uneven, several short lengths of the hook and loop can be attached strategically behind the textile.

Install slant boards at a maximum angle of 15° to reduce the stress of gravity on weakened textiles.

7. *What are the considerations for framing textiles?*

Small and medium-sized textiles can be framed with stitching techniques, or by using a specialized mount called a “pressure mount.” A stitched mount is an interventive technique that must be carried out by a textile conservator. A conservator or technician with specialized training constructs pressure mounts.

Specify the following in working with a conservator to frame a textile:

- Whenever possible, choose cotton fabric as the exhibition fabric. Linen is a second choice. Silk is a poor choice because of dye stability and poor light fastness. Wool is susceptible to insect infestation and should not be used.
- Exhibition fabric should be pre-washed to remove sizings and finishes.
- Wooden elements of stretcher frames should be made of low-resin wood (such as poplar). All wooden framing elements should be coated with an appropriate moisture-borne polyurethane varnish and thoroughly dried before use.
- Stretcher frames should be faced with archival matboard to provide a solid support for the mount.
- One or more layers of padding (thin polyester quilt batting or Pellon® fleece) should be placed behind the exhibition fabric for cushioning. Pressure mounts require several layers that are graded in size, to provide even support (see Question 13 below).
- Use Acrylic® as the glazing material. Avoid glass when working with textiles because it can break and damage the object. Specify ultraviolet-filtering Acrylic® in framing textiles if exhibition lighting conditions are imperfect.

- In a stitch-mount, make sure that the glazing does not come in contact with the textile. Archival mat board or thin acrylic strips at the edges of the frame can act as a spacer between the frame and the textile.
- Never turn under ragged edges or turn part of the textile over the edge of the stretcher. If the edges of the textile are unsightly, consider using a window mat of archival mat board to cover that part of the object.

8. *What is a pressure mount?*

A pressure mount uses the friction of the backing fabric and the glazing material (acrylic) to hold a textile in place without stitching. Padding behind the exhibition fabric provides cushioning to the textile object. This kind of mount is ideal for short-term exhibition of moderate to small-sized textiles and textile fragments. It is often the most suitable mount for somewhat brittle or fragile textiles that might be damaged by sewing techniques. A diagram of a typical pressure mount can be found in Figure K.13.

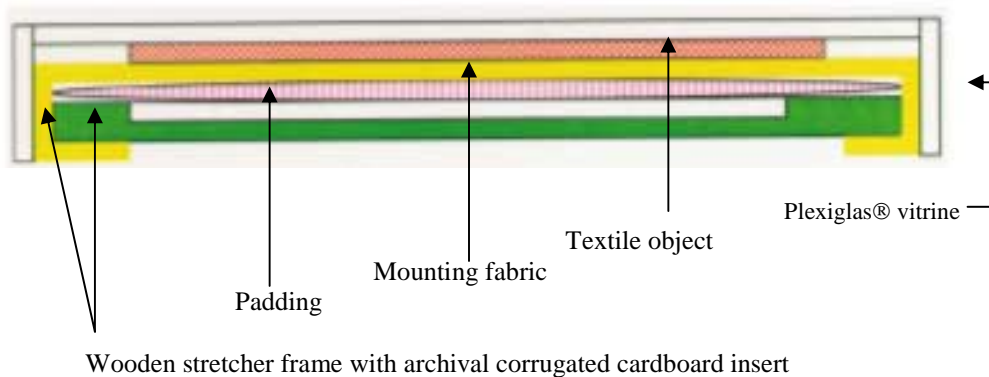

Figure K.13. Diagram of a pressure mount

9. *When do I know if a pressure mount is the most appropriate display method?*

A textile conservator should determine whether a pressure mount is appropriate for a specific textile. There are some risks in using this kind of mount even though no stitching is involved. The Plexiglas® face of the mount often carries a static charge. That charge can lift fibers from a brittle textile. In those cases, a slanted or flat mount in an exhibition case would be a better choice.

The other limit on pressure mounts is size. The maximum size of a pressure mount is limited by the size of acrylic sheet used for the face of the mount. It also is very difficult to maintain complete contact between the textile and the acrylic over a large span. Large sheets of acrylic bow at the center. It requires substantial padding, and sometimes trial and error, to create a pressure mount for a large textile.

L. Display of Historic Costumes

Wearing original historic costumes is unacceptable in a museum context. Accidents, perspiration, make-up, stress of dressing and wear, and sudden gestures or movements create excessive, immediate hazards that cannot be justified. Reproductions can be made and used for educational purposes in conjunction with appropriate display of the collection.

Each costume item should be carefully evaluated before deciding on a display method. If the seams and fabric are sufficiently strong, a mannequin may be the most appropriate choice. If the garment is fragile, it may be necessary to use a flat or slanted display. However, costumes are three-dimensional, and it is important to pad the interior of a garment to prevent folding and creasing.

Costumes need the support of a mannequin of correct size and proportion. The mannequin must represent the fashionable profile of the period to provide appropriate internal support. Certain period costumes may also require the construction of period undergarments such as bustles, hoops and corsets for correct presentation.

Bias cut garments prevalent in costume of the 1920s and 1930s should not be on extended display because of the tendency of the fabrics to stretch. Dresses of this period often have few closures and can be difficult to install on a mannequin.

No seams should be undone in order to put a piece on display.

1. *Where do I find appropriate mannequins to display costumes?*

There are several companies that provide both generic and custom-made mannequins for museum use (see Section R. Additional Resources below). Castoff store mannequins can sometimes be adapted for use. In particular, child and youth mannequins may be adapted to historic costumes that often are smaller in size than current adult clothing.

Simple supports can be constructed by carving polyethylene foam blocks to shape. These forms are covered with layers of batting to pad the form to the correct shape, and then can be finished with cotton knit “skin” (see Figure K.14).



Figure K.14. Polyethylene foam cut to the shape of a torso, then padded with quilt batting and covered with cotton knit.

2. *How do I display unconstructed garments?*

Traditional mannequins may not provide sufficient support for fragile, unconstructed garments like ponchos. An archival tube padded with quilt batting and covered with cotton fabric is a simple mount for display of these kinds of garments.

M. Conservation Treatment

The following section discusses particular considerations before any treatment is carried out either by park staff or a conservator. NPS policy emphasizes stabilization as the goal of conservation treatment. Maintenance of proper environmental control, use of appropriate storage and display techniques, and careful handling can reduce the need for costly, interventive conservation treatments.

1. *What NPS guidance is available to help me make decisions about conservation treatment?*

Review Chapter 3: Preservation: Getting Started, for information on the roles of the curator/collections manager and the conservator and information on the Collection Condition Survey (CCS). Refer to Chapter 8: Conservation Treatment, for information on conservation treatment issues and working with a conservator. In addition, *NPS Management Policies*, (Dec 2000) Chapter 5: Cultural Resource Management, discusses NPS policy for conservation treatment of museum objects.

2. *What kinds of treatment and maintenance can be undertaken by park staff?*

Park staff with appropriate training can undertake many maintenance activities associated with textile collections, such as:

- preparing appropriate storage housings
- constructing mannequins and other support mounts for exhibition
- vacuuming textiles, costume, upholstery and historic carpets on display to remove dust and protect from insect infestation

3. *What kinds of treatment and maintenance should be undertaken only by a conservator?*

All **interventive** treatments must be undertaken by a textile conservator including:

- wet and dry cleaning

- repair using needle and thread techniques
- consolidation with adhesives
- application of linings
- restorations and reconstructions
- specialized mounts (including stitched and pressure mounts)

There are many considerations in developing a conservation treatment. Some of the factors that a textile conservator will take into account before recommending a treatment are:

- no treatment is undertaken that is not absolutely necessary for the preservation, safe storage, or safe display of the object
- no treatment is completely reversible, so conservation should involve materials and methods that are the least harmful to the object
- treatment should not interfere with future research about the properties of the textile and the techniques used in its fabrication

4. *What cleaning methods are used on textiles?*

Cleaning of textile objects requires a different approach from that normally used for your own clothing. Even gentle cleaning is a drastic treatment, but it can be essential to the long-term preservation of a textile object (see Sections D.7 and D.9 above).

There are four categories of cleaning:

- surface (suction cleaning by vacuum)
- wet (cleaning with water or water plus detergent)
- dry (cleaning with organic solvents)
- spotting (treating of localized stains with wet or dry-cleaning solvents)

Wet, dry, and spotting treatments must be carried out by professionals. Vacuum cleaning is a regular form of maintenance of materials on open display, textiles being returned to storage, and newly acquired textiles before they are placed in storage or on display.

5. *What should I know about vacuuming textiles?*

Every park should have at least one vacuum cleaner that is reserved for use on museum objects. A vacuum with a HEPA filter (High Efficiency Particulate Air) that removes 99.97% of particulates 0.3 microns or larger in size is the most appropriate for removing dust and particulates from textiles (see *Conserve O Gram* 1/6: Choosing a Vacuum Cleaner for Use in Museum Collections, and *Tools of the Trade*). Your vacuum also should have a rheostat to allow for suction control. Most textiles should be vacuumed with very low suction. The upholstery or crevice wand is the best tool for vacuuming most textiles and upholstery; an upholstery brush works well on pile carpets.

It is easy to pick up loose threads and surface embellishments like embroidery when vacuuming. To prevent damage when vacuuming, protect the textile surface with polyester or nylon window screening. Sew cotton tape over the cut edges of the screen.

Figure K.15. Proper vacuuming technique. Loop the vacuum hose over your arm to keep from dragging it across the textile. Place the brush down on the surface of the screen. Lift the brush to move it to the next location (do not rub the brush back and forth across the screen).



6. *What techniques are used to repair textiles?*

Many repair techniques involve the use of needle and thread to close broken seams, compensate for fabric loss, or provide support to weakened areas. Work with a conservator to determine which repair technique is appropriate for your textile. Some questions you might want to discuss are:

- What is the goal of the treatment?
- Are repairs necessary to strengthen the textile structurally?
- Are repairs necessary to aesthetically improve the textile?
- What new materials will be introduced into the textile?
- Is it more appropriate to use synthetic or natural fabrics and thread for repairs?
- What is the wash and light-fastness of new materials?
- How will new materials be distinguished from the original?
- Will repairs of seams attempt to use original sewing holes?
- Will repair fabrics be dyed to a shade slightly different than the original?
- What kind of documentation will be used to record the use of new materials?

Some fabrics like weighted silks may be too brittle for needle and thread repairs. Adhesive techniques may be the only way to safely consolidate and repair those textiles. Adhesive techniques cannot be reversed easily. They also change the drape and “hand” of the fabric. Consider all of the options carefully before deciding on an adhesive treatment. You may want to discuss the following questions with the conservator:

- Are any other consolidation and treatment techniques available?
- Is it possible to use an overlay of translucent fabric or netting to hold the damaged areas in place?
- Are there less stressful display and storage techniques that could preserve the textile without further treatment?
- Will the textile continue to deteriorate or be in danger of further damage from handling if it is not treated?

Successful conservation treatment is the result of collaboration between the curator and conservator. Conservation treatments can be expensive and time consuming. Not all treatments result in striking visual changes. A well-structured plan and continuing communication with the conservator can avoid surprises and result in the best possible outcome.

7. *What textile conservation terminology should I be familiar with when talking to a conservator?*

Following are some of the common terms and practices used in textile conservation:

- **Wet cleaning.** Using water or water plus detergents to remove soils from a textile. Water is a powerful solvent. It can solubilize and react with dyes, degraded fibers, chemical pollutants, and other materials and additives found in and on a textile. Wet cleaning requires an understanding of the:
 - physical and chemical nature of the textile
 - source and chemical character of the water to be used
 - properties of the detergent system
 - type and nature of the soils to be removed

A textile conservator will always test the dyes and finishes of a textile before attempting wet cleaning to make sure that the textile can be safely treated.

- **Dry cleaning.** Cleaning using organic solvents with or without detergents or additives. Dry cleaning may be recommended when dyes or finishes are affected by water and there is no other safe cleaning treatment.

Dry cleaning solvents are extremely volatile and should only be handled by experienced professionals. Few historic textiles can withstand conventional dry cleaning. There are few dry cleaners offering hand cleaning. If dry cleaning is recommended, the conservator should provide supervision and

oversight to the cleaner undertaking the work.

- **Spotting.** Spotting or spot cleaning is the treatment of localized stains with water or an organic solvent. Spot cleaning requires specialized equipment to prevent the stains from migrating into surrounding areas. This technique is often used to remove oily stains from a textile prior to wet cleaning.
- **Support.** The term “support” can refer to materials that provide shape and structure (such as a mannequin) or materials used to stabilize weakened areas of a textile. A support also can be a box or tray used to safely transport a textile.

A support often is a piece of new fabric used as a *patch* or *backing*. Support patches and backings are attached by stitching or adhesive techniques. The fabrics are chosen for their visual and chemical compatibility with the original, as well as light and wash-fastness.

- **Mount.** A mount is a kind of support used to prepare a textile for exhibition or storage. Unlike other kinds of supports, mounts are not permanently attached to the textile. A few examples of mounts are:
 - mannequins
 - frames
 - slant boards
 - structures that provide shape to hats
 - cavity packs
 - padded hangers
- **Lining.** Linings are protective dust covers for the back of a textile. In a garment, linings are integral to the garment structure. A conservator may add additional linings to a garment to protect the original fabric from abrasion from handling or display on a mannequin. Linings for large wall-hung textiles, like tapestries, are usually a tightly woven fabric. Linings are separate from supports, and like mounts, are not permanently attached to the textile.

N. Packing and Shipping Textile Objects

For general information on packing and shipping museum collections see Chapter 6: Handling, Packing, and Shipping. Flat textiles, costumes, and costume accessories should be packed in boxes, and the boxes packed in crates. Rolled textiles should be immobilized in crates by polyethylene foam blocks that suspend the roll in the crate (see Figure K.16).



Figure K.16. Shipping crate with suspended textile rolls. (Photograph courtesy of Harold F. Mailand)

1. *Are there special considerations for packing and shipping textile objects?*

The condition of a textile will determine appropriate packing and shipping techniques. The most difficult situations will occur when it is necessary to ship a fragile textile to a conservator for treatment. Work with the conservator to determine the best method. In general:

- Roll medium to large-size flat textiles if possible. Roll the textile as you would for storage. Wrap clear polyethylene sheeting around the rolled textile and seal completely with packing tape to protect against water damage.
- Fragments and small textiles can be shipped in storage mats (see Appendix I, Figure I.8 Construction of a Portfolio Mount for Archeological Textile Fragments) or padded in archival boxes of various sizes. If you are using a box, be sure to use sufficient padding to fill the box completely. Polyethylene foam blocks covered with polyester batting and muslin are good for this purpose.
- Do not use crumpled tissue in packing textiles and costume. The tissue tends to shift and compress. Use tissue folded into pillows, or batting-stuffed cotton-knit “sausages” in place of crumpled tissue to pad folds and provide interior supports.

2. *Are there special considerations for packing and shipping framed textiles?*

Never ship textiles framed behind glass. Replace glass with acrylic (Plexiglas®). Always wrap framed textiles in clear polyethylene sheeting and seal with packing tape to protect against water damage. Use the “box-within-a-box” method to pack and ship framed textiles.

3. *Are there special considerations for packing and shipping costume accessories such as hats?*

Three-dimensional textiles require the same kinds of interior supports for packing and shipping as for storage. The ideal packing method for three-dimensional textiles are cavity packs within archival boxes (see Chapter 6, F.4).

O. Emergency Procedures for Textile Objects

Appropriate response to emergencies from a natural disaster or vandalism should be incorporated within the park's Emergency Operations Plan (EOP). Consider the following:

- Close off the affected area and assemble sufficient personnel to deal with the problem. Unnecessary or inappropriate handling can create greater loss than the initial situation.
- Prepare a clean, dry workspace. If the emergency includes water or other liquids, have fans and dehumidifiers ready.
- Be aware of the size of doorways, stairways, corridors, and objects that cause difficulty in maneuvering to get to the workspace.
- Deal first with objects that are in danger of additional damage, such as those hanging precariously or with elongated tears.
- Water-soaked textiles are heavy and weaker than when they are dry. Carry one object at a time. Use auxiliary supports such as rolling carts or trays to move wet textiles.
- Be careful to support the whole textile. Avoid handling by edges and corners to avoid stretching and tearing.
- Collect and preserve all fragments.
- No piece should be in contact with another object.
- The immediate danger to wet textiles is dye bleed and mold. Do not attempt to dry textiles with heat. Instead, set up fans and dehumidifiers, and try to absorb excess water. Your emergency supplies should include clean toweling and boxes of disposable baby diapers for this purpose.
- If the liquid is unknown, assume the worst. It might be a corrosive or caustic chemical that could cause damage to personnel. Do not flush the textile with water as this could spread the chemicals and cause further damage and additional chemical reactions. Locate protective equipment, warn other staff of the potential hazard, and contact the park or regional HAZMAT coordinator according to the park's EOP.

P. Glossary

Constructed Garment: clothing that has been made by cutting and piecing fabric(s) together. Most Western dress is made this way (see also: *unconstructed garment*).

Costume Accessory: objects associated with costume collections including hats, bonnets, shoes, gloves, purses, fans, umbrellas, and parasols

Dry Cleaning: textile conservation treatment using organic solvents and detergents

Dye: plant materials and various chemicals that add color to textiles

Felting: the process of using heat, water, and pressure to interlock loose fibers together

Fibers: the raw materials used to make textiles. Fibers come from natural (animal and plant) and synthetic sources and may also include metals and alloys.

Finish: manufacturing process to prepare textiles for use. Finishes include dyes, lubricants, chemical compounds, mechanical treatments, sizing, water and stain repellents, mothproofing, and flameproofing.

Lacemaking: a variety of techniques that involve the intricate twisting of fine threads to form a pattern

Lining: protective dust cover for the back of a textile. Linings for garments are integral to the garment structure.

Macramé: a knotting technique using more than one strand of yarn to create fringes and edgings

Mercerization: cotton processing technique using a strongly alkaline chemical to improve dyeing, add softness, and add flexibility

Mordant: chemicals (usually metallic salts) applied to yarn or cloth to fix dyes

Mount: a type of support used to prepare a textile for exhibition or storage

Netting: textile produced from a single, continuous strand by looping and knotting

Pressure Mount: a temporary framing technique for flat textiles

Retting: soaking flax to loosen fibers from the plant stem

Spinning: twisting short fibers together to make a long thread

Spotting: treatment of localized stains with wet or dry-cleaning solvents

Support: materials that provide shape and structure, or are used to stabilize weakened areas of a textile

Unconstructed Garment: clothing that uses the rectangular shape of fabric yardage for construction. This type of garment is common in many forms of ethnic dress such as Hopi and Pueblo clothing and Japanese kimonos.

Warp: the parallel yarns stretched on a loom (lengthwise)

Weaving: making cloth by interlacing threads of the warp and weft on a loom

Weft: the transverse yarns interlacing with the warp in a pattern

Weighting: an 18th and 19th-century silk processing treatment using metallic salts to produce fuller, heavier fabrics

Wet Cleaning: conservation treatment using water or water plus detergents

Q. Bibliography

General Topics

Barber, E.J.W. *Prehistoric Textiles*. Princeton: Princeton University Press, 1991.

Black, David, ed. *The Macmillan Atlas of Rugs and Carpets*. New York: Macmillan, 1985.

Cooke, Edward S., Jr. *Upholstery in America and Europe from the Seventeenth Century to World War I*. New York: W.W. Norton & Co., 1987.

Fiske, Patricia L., ed. *Imported and Domestic Textiles in Eighteenth Century America*. Washington, D.C.: The Textile Museum, 1976.

Ginsburg, Madeline. *The Illustrated History of Textiles*. London: Studio Editions, Ltd., 1991.

Harris, Jennifer, ed. *Textiles 5,000 Years: An International History and Illustrated Survey*. New York: Harry N. Abrams, 1993.

Knopp, Joel. *American Hooked and Sewn Rugs: Folk Art Underfoot*. Albuquerque: University of New Mexico Press, 1995.

McIntyre, Kellen K. *Rio Grande Blankets: Late 19th-Century Textiles in Transition*. Albuquerque: Adobe Gallery, 1992.

Montgomery, Florence M. *Textiles in America, 1650-1870*. New York: W.W. Norton Co., 1984.

Nylander, Jane C. *Fabrics for Historic Buildings*, 3rd ed. Washington, D.C.: The National Trust for Historic Preservation, 1983.

Orlofsky, Patsy and Myron Orlofsky. *Quilts in America*. New York: McGraw-Hill, 1974.

Parry, Linda. *Textiles of the Arts and Crafts Movement*. London: Thames and Hudson, 1988.

Fibers

Appleyard, H. *Guide to the Identification of Animal Fibres*. Leeds, UK: Wool Industries Research Association, 1960.

Cook, J. Gordon. *Handbook of Textile Fibres*, 5th edition (2 vols.). Shildon, UK: Merrow, 1984.

Hatch, Kathryn. *Textile Science*. Albany, NY: Delmar Publishers, 1993.

Structure and Techniques

- Burgess, J. Tom. *Knots, Ties and Splices*. London: Routledge and Kegan Paul, 1977.
- Burnham, Dorothy K. *Warp and Weft: A Textile Terminology*. Toronto: Royal Ontario Museum, 1980.
- Chadwick, Eileen. *The Craft of Handspinning*. New York: Charles Scribner's Sons, 1980.
- Collingwood, Peter. *The Techniques of Sprang*. New York: Watson Guptill Publications, 1964.
- _____. *Techniques of Rug Weaving*. London: Faber and Faber, 1968.
- Compton, Rae. *Illustrated Dictionary of Knitting*. Loveland, CO: Interweave Press, 1998.
- Dillmont, Thérèse de. *Encyclopedia of Needlework*. New York: Crescent Books, 1987.
- Earnshaw, Pat. *A Dictionary of Lace*. Aylesbury, UK: Shire Publications, Ltd., 1982.
- Emery, Irene. *The Primary Structures of Fabrics*. Washington, D.C.: The Textile Museum, 1966.
- Fisher, Joan. *The Art of Macramé*. London: Hamlyn, 1972.
- Gordon, Beverly. *Feltmaking*. New York: Watson Guptill, 1980.
- Hedlund, Catherine A. *A Primer of New England Crewel Embroidery*, 5th ed. Sturbridge, MA: Old Sturbridge Village, 1973.
- Levy, Santina M. *Lace: A History*. London: Victoria and Albert Museum, 1983.
- Proctor, Molly. *Victorian Canvas Work*. New York: Drake Publishers, Inc., 1972.
- Reigate, Emily. *An Illustrated Guide to Lace*. Suffolk, UK: Antique Collector's Club, 1986.
- Rutt, Richard. *A History of Handknitting*. Loveland, CO: Interweave Press, 1987.
- Smith, Doris M. *Encyclopedia of 300 Crochet Patterns, Stitches and Designs*. Peachtree City, GA: FC & A Publishers, 1992.
- Spark, Patricia. *Fundamentals of Feltmaking*. Coupeville, WA: Shuttlecraft Books, 1989.
- Stanfield, Lesley. *The New Knitting Stitch Library*. Asheville, NC: Lark Books, 1998.
- Tovey, John. *Weaves and Pattern Drafting*. New York: Simon and Schuster, 1978.

Dyeing, Printing and Finishing

- Adrosko, Rita. *Natural Dyes in the United States*. Washington, D.C.: Smithsonian Institution Press, 1968.
- _____. *Natural Dyes and Home Dyeing*. New York: Dover Publications, 1971.
- Bliss, Anne. *North American Dye Plants*. New York: Charles Scribner, 1980.

Gordon, Beverly. *The Final Steps: Traditional Methods and Contemporary Applications for Finishing Cloth by Hand*. Loveland, CO: Interweave Press, 1982.

Johnston, Meda Parker and Glen Kaufman. *Design on Fabrics*, 2nd rev. ed. New York: Van Nostrand Reinhold, 1981.

Montgomery, Florence M. *Printed Textiles: English and American Cottons and Linens 1700-1850*. New York: Viking Press, Inc., 1970.

Storey, Joyce. *Dyes and Fabrics*. London: Thames and Hudson, 1978.

Costume and Costume Accessories

Anthony, Pegaret and Janet Arnold. *Costume—a General Bibliography*. London: Costume Society, 1974.

Boucher, François. *20,000 Years of Fashion—a History of Costume and Personal Adornment*. New York: Harry N. Abrams, Inc., 1987.

Bradfield, Nancy. *Costume in Detail: 1730-1930*. London: Harrap, 1981.

Cumming, Valerie. *Visual History of Costume Accessories: From Hats to Shoes – 400 Years of Costume Accessories*. London: BT Batsford, 1998.

Norris, Herbert. *19th Century Costume and Fashion*. New York: Dover Publications, 1999.

Torta, Phyllis G. and Keith Eubank. *Survey of Historic Costume: A History of Western Dress*. New York: Fairchild Publications, 1998.

R. Additional Resources

Handling, Storage, and Care

Canadian Conservation Institute. *CCI Notes*. Ottawa: Canadian Conservation Institute
1030 Innes Road
Ottawa, Ontario
K1A 0C8
Canada
<<http://www.cci-iic.gc.ca/>>

Rose, Carolyn L. and Amparo R. de Torres, eds. *Storage of Natural History Collections: Ideas and Practical Solutions*. Pittsburgh, PA: Society for the Preservation of Natural History Collections, 1992.
Society for the Preservation of Natural History Collections (SPNHC)
<<http://www.spnhc.org/>>

National Park Service. *Conserve O Gram*. Washington, DC: National Park Service.
<http://www.cr.nps.gov/museum/publications/consveogram/cons_toc.html>

The Textile Museum <<http://www.textilemuseum.org/care.htm>>
“A Hanging System for Textiles in Sturdy Condition”
“Storing Oriental Rugs”
“Guidelines for the Care of Textiles”
“Pestbusters”

Conservation Resources

Conservation On-Line: <<http://palimpsest.stanford.edu/>>

American Institute for Conservation of Historic and Artistic Works (AIC): <<http://palimpsest.stanford.edu/aic/>>

Mannequins

Dorfman Museum Figures, Inc.: <<http://www.museumfigures.com/>>

Anatomic Studio: <<http://www.anatomic.net/>>

Professional Societies and Research Organizations

Costume Society of America
<<http://www.costumesocietyamerica.com/>>

Pasold Research Institute (publishers of the periodical *Textile History*)
<<http://www.maney.co.uk/textilehistory.html>>

Textile Society of America
<<http://textilesociety.org/>>

Appendix L: Curatorial Care of Easel Paintings

	<u>Page</u>
A. Overview	L:1
What information will I find in this appendix?.....	L:1
Why is it important to practice preventive conservation with paintings?.....	L:1
How do I learn about preventive conservation?.....	L:1
Where can I find the latest information on care of these types of materials?.....	L:1
B. The Nature of Canvas and Panel Paintings	L:2
What are the structural layers of a painting?.....	L:2
What are the differences between canvas and panel paintings?.....	L:3
What are the parts of a painting's image layer?.....	L:4
C. Factors that Contribute to a Painting's Deterioration	L:5
What agents of deterioration affect paintings?.....	L:5
How do paint films change over time?.....	L:5
Which agents of deterioration will affect my collection the most?.....	L:5
How does the environment affect my collection?.....	L:6
What are the ideal temperature and RH range for paintings?.....	L:6
How does light affect paintings?.....	L:6
What kind of pollution affects paintings?.....	L:7
How can I control pollution in my museum or display area?.....	L:7
Are museum pests attracted to paintings?.....	L:8
How can faulty handling affect a painting?.....	L:8
How can past treatments adversely affect a painting?.....	L:8
How do I know if a painting is actively deteriorating?.....	L:9
D. Proper Handling and Storage of Paintings	L:9
What do I need to consider before handling a painting?.....	L:9
What do I need to know about the storage of paintings?.....	L:10
Where should I store my paintings?.....	L:10
How should I store my paintings?.....	L:11
E. Exhibiting Paintings	L:13
What do I need to consider when I am planning an exhibit?.....	L:13
What do I need to consider when installing the exhibit?.....	L:13
How do I properly hang a painting?.....	L:13
How do I prevent touching and vandalism?.....	L:14
How do I do safe housekeeping?.....	L:14
F. Proper Shipping of Paintings	L:14
What do I need to consider before loaning my paintings?.....	L:14
G. Conservation Treatment	L:15
Why should I contact a conservator?.....	L:15
What might a conservator be able to tell me about my painting upon examination?.....	L:15
What might a conservator do to stabilize my painting?.....	L:16
What might conservators do to restore my painting?.....	L:16
H. Procedures for Handling Paintings During Emergencies	L:17
In what ways can a disaster affect my paintings?.....	L:17
What do I do if my paintings are water damaged?.....	L:17
What should I do in the case of an emergency that is NOT water-related?.....	L:17

	<u>Page</u>
I. Glossary of Terms Used for Condition Reporting When Examining Paintings	L:18
J. Selected World Wide Web References	L:19
K. Selected References	L:19
List of Figures	
Figure L.1. A cross-section of a painting.....	L:3
Figure L.2. Proper way to carry a small painting	L:10
Figure L.3. Paintings stacked against a wall	L:12

APPENDIX L: CURATORIAL CARE OF EASEL PAINTINGS

A. Overview

1. *What information will I find in this appendix?*

This appendix discusses the physical structure of easel paintings and outlines their long-term care and preservation. Easel painting is historically a European technique using canvas or wooden panels for the image support. The main topics covered in this appendix are:

 - canvas and panel painting materials, structure, and construction
 - agents of deterioration
 - handling, storage, display, and transportation of paintings
 - working with a conservator when treatment is needed
 - specific emergency procedures for paintings

This appendix does not cover works of art on paper, such as watercolors, scroll paintings, or screens. These materials are covered in Appendix J: Curatorial Care of Paper Objects. This appendix also does not include painting techniques typically associated with architecture, such as fresco and mural painting.
2. *Why is it important to practice preventive conservation with paintings?*

Preventive conservation aims to prevent harm to an object before it occurs. This practice will decrease the need for costly and time-consuming conservation treatments. Paintings are very delicate because they are composite objects made up of a variety of materials. Many factors contribute to their deterioration. A painting's rate of deterioration slows significantly with proper preventive care. Practicing preventive conservation also reduces the likelihood of accidents.
3. *How do I learn about preventive conservation?*

Learn about the **agents of deterioration** that affect paintings so that you can create a preventive conservation plan. These agents are discussed in detail in section C. Understanding how to protect your paintings from the agents of deterioration will increase the longevity of your paintings. See Chapter 3: Preservation: Getting Started, and Chapter 4: Museum Collections Environment, for a discussion on the agents of deterioration. Also refer to *Museum Handbook*, Part III (*MH-III*), Chapter 7: Using Museum Collections in Exhibits.
4. *Where can I find the latest information on care of these types of materials?*

There are a variety of sources for up-to-date information about paintings:

 - Read the NPS *Conserve O Gram* series.
 - Review the references in the bibliography. Especially note practical information found in *CCI Notes*, Section 10, Paintings.

- Look up the World Wide Web sources that are listed at the end of this appendix.
- Consult a painting conservator.
- Consult a curator or collection manager of a large painting collection.

B. The Nature of Canvas and Panel Paintings

Paintings are *composite* objects made up of several distinct parts. Artists create paintings by preparing a support and then painting an image on that support. These two main components of a painting are called the *support* and *image layers*. Both the support and image layers are usually composed of two or more parts. These parts often react differently to external conditions, like temperature and relative humidity (RH), placing stress on the object. Because of this complexity, paintings are delicate objects that must receive specialized care in order to remain in optimum condition.

1. *What are the structural layers of a painting?*

The two principal layers are composed of these parts:

Support layer:

- auxiliary support
 - stretcher or strainer (canvas paintings)
 - mount or cradle (panel paintings)
- support
 - canvas (canvas paintings)
 - wood (panel paintings)

Image layer:

- sizing
- ground
- paint film
- varnish

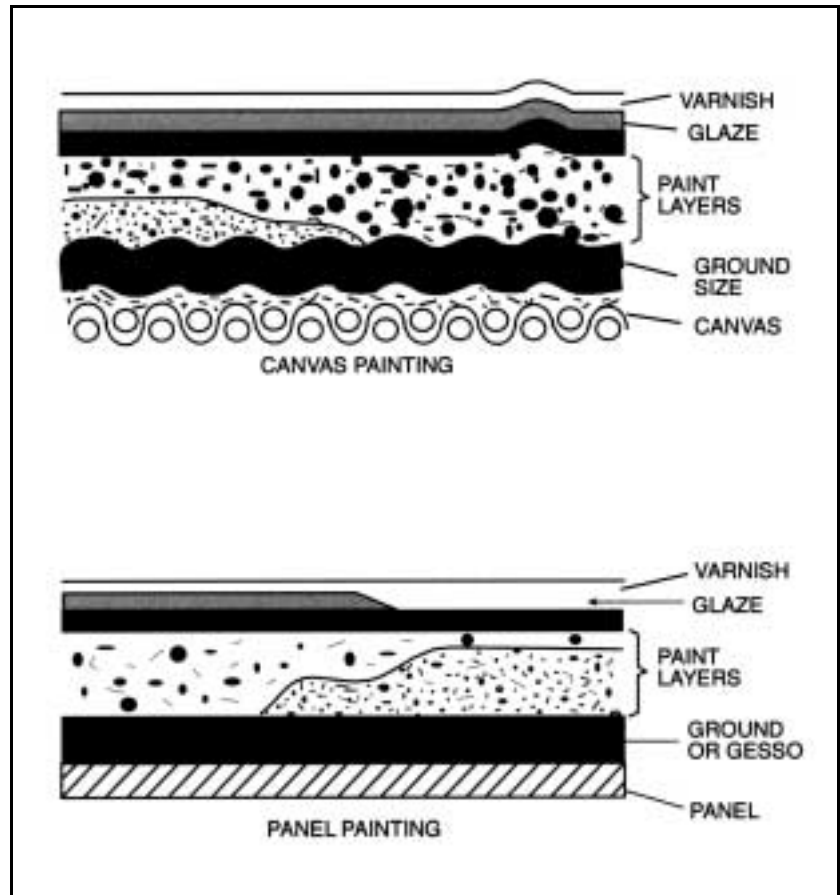

Figure L.1. A cross-section of a painting

Not all canvas and panel paintings have all of these elements. For example, many acrylic paintings are not varnished. Folk artists often paint directly onto wood without first applying sizing or ground. Modern artists often incorporate other materials into the image layer, such as pieces of glass, textiles, paper and plants. Some specialized painting techniques will have different image layer elements from those discussed in this appendix. For example, the encaustic method uses paints that contain a beeswax and resin medium. The painted image is fixed with heat after it is applied to the support. Use the information in this chapter as a guideline for identifying your painting's layers, but realize that it doesn't cover every painting technique.

2. *What are the differences between canvas and panel paintings?*

Canvas paintings consist of a piece of fabric—usually linen, cotton, hemp, polyester, or silk—that is stretched over and attached to a wooden strainer or a stretcher. The fabric (canvas) is the support for the image layer, and the stretcher or strainer is the auxiliary support.

A **strainer** is a wooden frame with secured corners that are joined with glue, nails, or screws. Strainers cannot be enlarged mechanically.

A **stretcher** is a wooden frame constructed to open out at the joints and tighten the canvas. Small, triangular wooden wedges called **keys** are fit into slots on the inner joints of the stretcher to tighten it. This action is called “keying out.”

If the stretcher or strainer is damaged or warped so that it does not properly support the canvas, the image layer will also be damaged. The structural stability of a painting is dependent on a sound foundation.

Panel paintings are paintings on wooden supports. The cut of the wood, the type of wood, and the age of the wood are just a few of the factors that influence how prone a panel is to warping. Some panel paintings have an auxiliary support called a **cradle**. A cradle is a system of wooden bars that run in a grid pattern along the back of a panel. It has two purposes: to add support to the panel and to prevent the panel from warping. However, sometimes cradles actually cause the panel to warp or crack because they restrain natural movement of the panel due to changes in RH.

3. *What are the parts of a painting's image layer?*

The image layer is the paint film with one or more of the following layers:

- **Sizing** is a solution applied to raw canvas or a wooden support to fill in porous surfaces. Sizing reduces the support's absorbency so that the other layers do not soak into the support. If the ground or paint layers sink into the support, the support will become brittle. Traditionally, sizing is made of glue, varnish, starch, or gelatin. Today, acrylics and other synthetics are often used.
- **Ground** is an opaque coating that is applied to the support. It provides texture and evens out the painting surface. Painters often add pigment to the ground, which adds an overall tone to the painting. Common colors include red, brown, and gray. A material that has been used for centuries is "gesso," which is often made from chalk mixed in rabbit skin glue. Many synthetic alternatives are currently used.
- **Paint film** is the image layer composed of finely-ground **pigments** mixed with a **medium**, which binds them together. The pigments are what give the paint color. They are either inorganic (minerals, metals, and earths) or organic (vegetal, animal and synthetic dyes). The most common ingredients in paint mediums are drying oils (like linseed and walnut oil), egg yolk (in tempera paint), synthetic resins (like acrylics), and beeswax (in encaustic paintings).
- **Varnish** is a transparent, protective film that is brushed onto a dried painting. It protects the paint and saturates the colors. It was traditionally made from natural resins that are dissolved in oil or solvent. Synthetic varnishes and acrylic resins are the most modern varnishes. Varnish should never be applied to a painting that has not dried properly. Because some oil paints can take a long time to dry, artists often sold paintings with the instruction to varnish in a year's time.

The image you see when looking at a painting is created by the interaction of these layers. The image will change as colors darken, become lighter, yellow, or even fade completely. Physical changes such as cracks, crazing, or bulges may distort the surface. Some of these changes are appreciated as patina of age; others are less desirable, especially if there is a chance that part of the image will be lost if left untreated.

C. Factors that Contribute to a Painting's Deterioration

1. *What agents of deterioration affect paintings?*

Many factors contribute to a painting's deterioration. *These agents of deterioration* can occur naturally, or they can result from external forces. Avoiding agents of deterioration is the key role of *preventive conservation*. The agents are:

- direct physical forces, such as shock, vibration, and abrasion
- thieves or vandals
- fire
- water
- pests, such as insects, vermin, or mold
- contaminants, such as air pollution or dust
- ultraviolet and visible light
- high, low, or fluctuating temperatures
- high, low, or fluctuating relative humidity

For more information about these agents of deterioration, see Chapter 3: Preservation: Getting Started.

2. *How do paint films change over time?*

All layers in a painting deteriorate and take on different physical characteristics over time. Paint may become brittle and inflexible, varnish may discolor, and supports may become warped. Changes in temperature and relative humidity affect older paintings more than younger paintings because their materials become less resilient as they age.

Varnish oxidizes with light and air, eventually turning yellow or brown. It can lose transparency, turning milky in appearance. This opacity is called "bloom" and is caused by fingerprints and high relative humidity. Dirt and grime slowly accumulate on the surface, further obscuring the paint layer. Old varnish can also crack, sometimes resulting in damage to the paint layer.

When paintings are in good condition, their *paint films* are flexible, and they usually adjust to the expansion and contraction of their supports. However, most paint becomes brittle over time. When an older painting's support changes dimensions, deteriorating paint film may crack. Cracking paint will eventually begin to flake and fall off the support. This loss is irreversible.

3. *Which agents of deterioration will affect my collection the most?*

The following four agents of deterioration are the most likely to cause damage to your paintings:

- temperature

- relative humidity (RH)
- light
 - visible light
 - ultraviolet (UV) radiation
- pollution

Knowing the ideal settings for temperature, RH, and visible light, and knowing how to filter UV radiation and pollution is essential for preserving your collection.

4. *How does the environment affect my collection?*

Temperature, relative humidity, light, and pollution directly affect the rate at which a painting ages. Storing and displaying paintings in areas where temperature and RH are too high or low will increase deterioration rates. Constant fluctuation in temperature and RH is harmful, too, because it causes the materials in the paintings to continuously expand and contract. This often leads to flaking paint. Natural and artificial lighting can cause pigments to fade. Ultraviolet radiation is harmful to all parts of a painting. Atmospheric pollutants can settle onto a painting's surface, masking the artist's image. Pollutants can also break down the chemicals in paint and varnish, acting as a catalyst of deterioration.

Creating an ideal environment for your collection will extend the longevity of your paintings.

Temperature and RH have tremendous effects on paintings. Many structural layers in a painting are *hygroscopic*--they readily take up and retain moisture. Wood and sizing are particularly hygroscopic. Changes in RH greatly affect these materials. Wood will expand and contract, and subsequently, can twist and warp. Sizing causes a canvas to shrink with dryness and expand with moisture. These changes can be devastating to the entire painting, especially when the paint layer becomes brittle and cannot conform to these changes.

The key to preserving paintings is maintaining stable temperature and RH levels. You must avoid extreme fluctuations in RH and temperature. If you change a painting's environment, do it gradually.

5. *What are the ideal temperature and RH ranges for paintings?*

Store paintings at temperatures between 64° and 75° F (18° to 24° C). Temperature is less important for paintings than RH, but sudden temperature changes can harm paintings. For example, moving a painting from a cool to a warm area can cause moisture to condense on the surface. Maintain a RH of 40% to 55%. Low RH levels (under 35%) can embrittle all parts of a painting and encourage cracks and losses. High RH levels (over 65%) encourage mold growth. Decide on a "set point," and keep temperature and RH as close to this point as possible. See Chapter 4: Museum Collections Environment, for a discussion of proper environment and methods to control that environment.

6. *How does light affect paintings?*

Many pigments are sensitive to light and will eventually fade upon repeated exposure to light. Light can also be a catalyst for the deterioration of the paint medium. Light damage is cumulative and irreversible. Light damage depends on the type of light (ultraviolet and/or visible), intensity of the light, and

duration of exposure. Evaluating your collection's lighting conditions and making appropriate adjustments can prolong the life of your collection. Review the natural and artificial light sources in your storage and display areas. Use monitoring equipment to identify levels of UV radiation and illuminance (levels of visible light measured in "lux").

Reduce your collection's exposure to light by storing and displaying paintings in rooms without windows. If this is not possible, use tinted UV-absorbing films on the windows. (Clear UV-absorbing films will reduce UV levels, but will not reduce illuminance.) Cover all windows with drapes or blinds to further protect paintings. Also, avoid storing and displaying paintings in rooms with doors that open to the outside.

For many situations 50 lux is enough light to view a painting. In cases where higher illuminance is needed, don't allow visible light levels to go above 200 lux. All UV light should be filtered. Consider ways to limit the total light exposure, such as automatic dimmer switches or simply turning out lights when visitors are not present.

Don't use traditional picture lights that are hung just over a painting or on the frame. They concentrate light onto a small portion of the painting, creating light and heat damage. When they are mounted on the frame, their weight strains the entire structure.

7. *What kind of pollution affects paintings?*

Outdoor pollutants, such as dust and pollen, can easily be brought into a museum through open doors and windows. Industrial emissions as well as natural processes of erosion create these pollutants. Cleaning products, asbestos fibers, building materials, paint, carpeting, and other indoor materials can generate pollution within a museum. Cigarette, cigar, and pipe smoke are also harmful forms of pollution.

8. *How can I control pollution in my museum or display area?*

Follow these practices:

- Keep doors, windows, and outside vents closed whenever possible.
- Never allow smoking or fireplace fires in the building.
- Choose new building materials, paints, and carpeting that do not emit harmful gasses.
- Don't use custodial cleaners that emit harmful gasses (for example, ammonia).
- Use appropriate pollution filters in your HVAC system.
- Cover paintings in storage.
- Keep particularly vulnerable objects in sealed display cases. Make sure these cases meet the recommendations in *MH-III*, Chapter 7: Using Museum Collections in Exhibits, and NPS *Exhibit Conservation Guidelines*.

For more information on controlling pollutants, see Chapter 4: Museum Collections Environment.

9. *Are museum pests attracted to paintings?*

Some paintings are extremely attractive to pests, depending on their materials. Termites and other wood-boring pests can damage the wood in panel paintings, in stretchers, and in frames. Rodents have been known to nibble at paintings. Insects, such as moths, silverfish, and beetles, like to eat fabric. The gelatin in size and the egg yolk in tempera paint are also attractive to pests. Mold can destroy canvas. Develop an integrated pest management plan (IPM) to protect your paintings and other objects in your collection to prevent these problems. For more information about IPM and pest infestation, see Chapter 5: Biological Infestations.

10. *How can faulty handling affect a painting?*

Improper handling can affect a painting in various ways:

- Moving a painting suddenly can cause cracks in any of the layers.
- Touching a painting's surface often results in scratches and discoloration of varnish, and can dislodge flaking paint.
- Touching the back of the canvas can undermine the surface layers.
- Picking up a painting by the top of the frame can cause strain to the joints in the frame and stretcher/strainer, damaging the entire painting.
- Picking up a painting that is too large for one person to handle can result in a jolting fall.
- Keying-out a stretcher improperly can over-stretch the canvas, creating cracking and flaking.

Many things happen to a painting during its lifetime that do not show immediate damage, but will surface as the painting ages.

Any pressure applied to a painting can cause hairline cracks that will eventually create problems. This pressure may occur when someone marks the back of a painting or glues a label to it. An improperly framed painting will create strain on the canvas that may not be evident for years. These small problems will escalate over time and eventually require treatment. You must take care now so that the objects in your collection will not deteriorate to the point where treatment is needed.

11. *How can past treatments adversely affect a painting?*

The notion of “treatment” has changed significantly through the years. In the past, paintings were taken to “restorers” rather than “conservators.” The emphasis was often on restoring the appearance of the painting, and quite often no consideration was given to the historical importance of the piece. Some restorers slapped patches on the back of a canvas, or sloppily glued on a lining. This has often caused the image layer to flake on the front side of the painting. Restorers sometimes repainted part or all of the surface of a painting. This “overpainting” altered the original image. Some restorers covered their overpainting with brown varnish to give the new paint an old look. Many restorers were careless when they cleaned a painting, removing the original paint along with the varnish. Some restorers just added another layer of varnish on top of everything, including the old varnish and dirt.

12. *How do I know if a painting is actively deteriorating?*

The main purpose of examining paintings is to detect problems as early as possible, and to act accordingly. Carefully examine a painting to identify damage and active deterioration. See Section K for a glossary of terms to use when describing the condition of paintings. In particular, when examining paintings look for these indications of active deterioration:

- cracks in the varnish and/or paint layer
- mold on the canvas or frame
- evidence of pest infestation, such as shed skins and droppings collected in the frame
- rusty or loose hooks and hanging wire
- warping in the frame or stretcher
- slackness in the canvas

These are all indications that your painting may have problems. Some of these problems, if left untreated, may lead to irreversible damage.

D. Proper Handling and Storage of Paintings

1. *What do I need to consider before handling a painting?*

Following are a few guidelines:

- Never touch the paint surface or push on the canvas from the reverse.
- If loose paint is present, carry the painting flat.
- Wash your hands before handling a painting.
- Always wear clean white cotton gloves.
- Clean all surfaces that the painting will touch.
- Check the stretcher keys to ensure that they are secure.
- Carry paintings with both hands on either side. Don't lift the top of the frame or stretcher.
- Carry only one painting at a time.
- Never carry a large painting by yourself. Get another person to help. If it is still too large to handle, place it on a trolley or cart that is well padded and in good condition. An old, rickety cart may produce enough shock to damage a painting.
- Know the painting's destination before you handle it. If you are moving it to hang it, have the mount prepared. If you are moving it to pack it for transport, have the packaging prepared for it. If you are moving it for

examination purposes, make sure you have set padded blocks on your table for its arrival.

- Never stack paintings on top of each other.

Proper handling of paintings is very important. As a general rule, do not handle a painting (or any other museum object) unless it is absolutely necessary.

For more information on handling, see Chapter 6: Handling, Packing, and Shipping.



Figure L.2. Proper way to carry a small painting

2. *What do I need to know about the storage of paintings?*

Improper storage of paintings can be a catalyst for deterioration. Consider the elements that affect a painting in storage.

- Control the agents of deterioration.
- Choose appropriate storage space and equipment. See Chapter 7: Museum Collections Storage.
- Ensure that proper security and fire detection and suppression equipment is installed and maintained. See Chapter 9: Security and Fire Protection.

3. *Where should I store my paintings?*

Your collection size is an important consideration when you determine where to store your paintings. If you have many paintings, consider creating a dedicated storage room. If you have only a few paintings in your collection, dedicate a space in your museum storage area for your paintings:

Never store paintings:

- in attics and basements
- against exterior walls
- near furnaces or heating/air conditioning vents
- in spaces below water pipes
- near sources of asbestos, such as old insulation or wiring
- in areas of extreme vibration, such as well-traveled walkways

Always store paintings at least four inches from the floor to minimize dirt and dust collection on surfaces and to protect them from flooding.

Always remove hanging wires, hooks, and all other hanging devices from a painting before storage. These can easily pierce canvas, and can scratch varnished surfaces and frames.

4. *How should I store my paintings?*

There are three main ways to store paintings:

- Hang them from storage screens.
- Place them on storage shelves.
- Stack them vertically against an interior wall or side of a cabinet.

Do not stack paintings against a wall or cabinet unless you have no other option. ***Never lean paintings against exterior walls.***

However you store paintings, it is helpful to fit canvas paintings with protective backing boards (see *CCI Notes 10/10, Backing Boards for Paintings on Canvas*). Backing boards prevent damage by blocking the reverse of the canvas with a rigid material so it cannot be knocked or pierced. It also buffers RH and temperature next to the canvas. The board is attached to the back of the frame using stable metal screws and plates. Don't use this technique on important historic frames. Contact a conservator if you have questions about attaching backing boards.

Storage screens are constructed of a vertically standing wooden frame onto which fencing material or rigid wire mesh screening is attached. Paintings in good condition are then hung from the screens by rigid hooks. This is a particularly useful painting storage method if your storage area is in an earthquake zone. Paintings without frames, of course, cannot be stored on storage screens because these paintings aren't equipped for hanging.

Conserve O Gram 12/1, Storage Screens for Paintings, provides instructions for constructing storage screens.

Note: Paintings that are not in good condition, especially paintings with flaking paint, should not be stored in a vertical position. Lay damaged paintings flat on shelves.

Storage shelves can be constructed of coated wood or metal and can be either horizontal or vertical (sometimes called storage bins). Storage shelves are recommended for smaller painting collections because empty shelves can be used to store other museum objects. (See *CCI Note 10/3*.) It is inadvisable to store more than one painting in each vertical compartment, but if you must, protect the paintings by placing heavy-duty, acid-free cardboard between them. The cardboard must be larger than the largest painting in each compartment. Never stack paintings horizontally.

Stack paintings vertically against a wall. This method is for temporary storage only and only for paintings in good condition. Lean them against a wall, resting on skid-proof, padded blocks. Make sure the blocks are at least four inches from the ground to avoid potential flood damage. Separate paintings from each other with heavy-duty, acid-free cardboard. The cardboard must be larger than the largest painting that will rest against it. Keep paintings of relatively the same size together, and never stack more than a few paintings on each set of blocks. The stacking angle is very important. Keep the stack's angle as close to vertical as possible, but make sure that the paintings can't topple forward. If the angle is too great, the paintings may collapse backwards onto each other. If an unframed painting has to be stacked in this manner, construct a temporary frame. You can place dust covers of washed cotton muslin over the paintings as additional protection. Do not allow the fabric to touch painted surfaces.

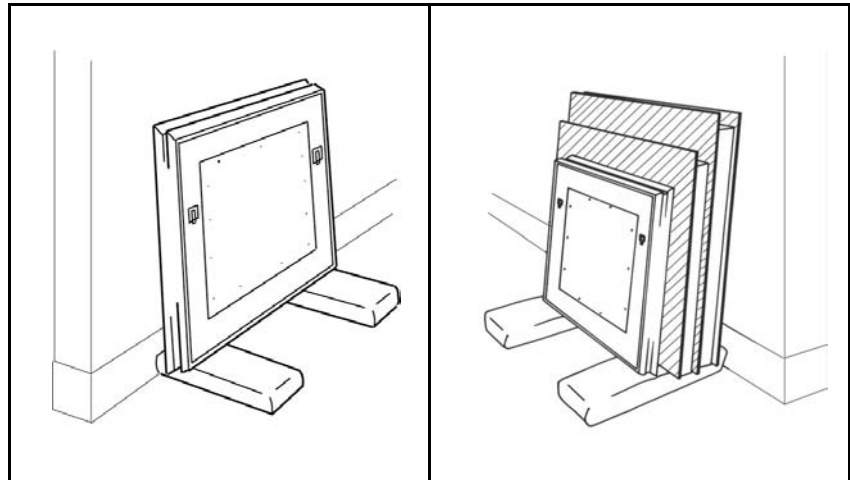

Figure L.3. Paintings stacked against a wall. Redrawn from *CCI Notes 10/2, Figure 1, and 10/3, Figure 1*.

Never stack a damaged painting against a wall.

E. Exhibiting Paintings

1. *What do I need to consider when I am planning an exhibit?*

When you prepare for an exhibit, you need to consider many factors. Refer to *MH-III*, Chapter 7: Using Museum Collections in Exhibits. In addition to factors such as environmental conditions and painting stability, think about:

 - placement of paintings
 - flow of traffic
 - protection from touching and vandalism
 - housekeeping requirements
2. *What do I need to consider when installing the exhibit?*

It is very important to make sure that the placement of paintings will not put them in jeopardy. Follow this advice when installing the exhibit:

 - Hang paintings away from doors, furniture, or other objects that could bump into the painting.
 - Set up the display in a way that is conducive to the optimal movement of visitors.
 - Hang paintings in open areas to lessen the chance of visitors brushing up against them.
 - Hang paintings away from heat sources, like vents, radiators, and light sources.
 - Ensure the security of the paintings.
 - Ensure that light sources will not emit UV and that visible light levels on paintings are below 200 lux.
3. *How do I properly hang a painting?*

Use extreme caution when hanging paintings. Improper hanging procedures can allow a painting to fall or allow a theft. Periodically check your paintings to make sure that hangers, hooks, nails, screws, “D”-rings, and all other hanging hardware are securely fastened and not rusty. Make sure that the wall where you hang paintings is strong enough to support the weight. Hang paintings with picture hooks (not nails) and use two hooks for heavy paintings. Drill holes in concrete walls or in studs, not in plaster or sheetrock.

Many paintings are hung by “hanging wire” that is secured to the back of the painting. Hanging wire can become loose if not properly attached and can rust easily, so check it often. To improve security of hanging paintings see *Conserve O Gram 2/7*, Fabricating Secure Hangers for Framed Works of Art.

4. *How do I prevent touching and vandalism?* Paintings on exhibit are tempting targets for touching and vandalism. Follow these guidelines to prevent the possibility of these hazards:
- Station an employee or security guard in the display room.
 - Use guard rails, ropes, platforms, or other deterrents.
 - Place "Don't Touch" warning signs near paintings.
 - Install security alarms wherever appropriate.
5. *How do I do safe housekeeping?* If paintings and frames become dusty, you may dust them, but first, carefully examine each painting for loose or flaking paint. If the surface is stable, dust with soft, white-bristle Japanese brushes, or sable or badger-hair brushes. Don't use feather dusters that can scratch paintings. Never try to wet clean a painting yourself or use any liquid or commercial cleaners on a painted surface. Commercial preparations can cause irreparable damage to the fragile layers of a painting. Explain the potential dangers of dusting and cleaning paintings to all staff.
- Avoid using pesticides, foggers, air fresheners, or furniture sprays near artworks. Remove paintings from a room before painting, plastering, or steam cleaning carpets or wallpaper. Make sure that cleaning staff are careful with mop and broom handles, which can scratch or puncture a painting. Never use spray cleaners, aerosols, or plant misters in the display rooms because the cleaner or water can settle on the paintings' surfaces. Avoid using very wet mops that can raise the RH.
- Refer to Chapter 13: Museum Housekeeping, for additional information.

F. Proper Shipping of Paintings

Unlike people, paintings will live longer if they lead a sedentary life. Shipping a painting increases the likelihood of damage, which could decrease its lifetime. Improper handling, vibration, shock, and uncontrolled temperature and RH are all potential threats to paintings during shipping. In most cases, the reason to ship paintings will be to loan them to another museum or gallery for an exhibition or to a conservator for treatment.

1. *What do I need to consider before loaning my paintings?* Before agreeing to loan your paintings, you must first assess their condition, and then decide if they can handle the move. If a painting is in good condition, it will probably survive travel with little harm, provided that it is packed and transported properly. Fit the painting with a protective backing board (see *CCI Notes* 10/10, Backing Boards for Paintings on Canvas). Backing boards will protect the canvas. Keep the following in mind:
- In general, travel will impact small, light paintings less than large, heavy paintings.

- Don't loan paintings that are fragile, have flaking paint, or are otherwise in poor condition.
- Canvas paintings that are too slack or that have uneven tension can be easily damaged during transportation because the canvas moves easily. Correct any problems with tension before shipping the painting.
- Paintings with holes, tears, or other damage should not travel because of their vulnerable state.
- Large panel paintings, especially those with separate pieces of wood bonded together, are more likely to bend and flex with the vibrations of transport.

See *MH-III*, Chapter 1: Evaluating and Documenting Collection Use, for information on loans. For in-depth information on proper packing procedures, materials, and supplies, see Chapter 6: Handling, Packing, and Shipping (this volume).

G. Conservation Treatment

1. *Why should I contact a conservator?*

There are many reasons to contact a painting conservator, who is trained to examine, analyze, stabilize, and treat paintings. See Chapter 3: Preservation: Getting Started, for information on choosing and contracting with a conservator. Be sure you check references and question the experience and background of any conservator you choose. Talk over any recommended treatments and be sure you understand what is planned and why it is necessary.

Only experienced conservators who agree to follow the AIC Code of Ethics and Guidelines for Practice should be allowed to treat paintings.

Only an expert should clean a painting that has discolored. Flaking paint and tears in the canvas will only become worse without conservation treatment. Water-damaged paintings require immediate conservation treatment. Fire-damaged paintings will usually have blistered paint, as well as a soot covering, and need expert care.

Never attempt to clean paintings or to treat damaged paintings yourself.

2. *What might a conservator be able to tell me about my painting upon examination?*

When conservators thoroughly examine paintings, they will make a number of observations. Conservators will identify the paint medium, the type of varnish, and the type of sizing. The examination may reveal underpainting below the visible image. Conservators are also able to judge the state and extent of deterioration in your paintings and to recognize past conservation/restoration treatments. This knowledge combined with their art historical understanding, enables conservators to make treatment proposals for your paintings.

3. *What might a conservator do to stabilize my painting?*

There are hundreds of treatment procedures involved in painting conservation. The treatment(s) your conservator uses will decrease your painting's rate of deterioration. Conservation treatments for paintings involve methods that will stabilize and/or restore paintings.

There are many variations in the treatments that conservators do, but typical stabilization might include one or more of the following:

- ***Framing or reframing*** to give structural protection to the painting
- ***Minor repairs to the canvas*** to remove dents or bulges or patch small holes
- ***Minor repairs to panels*** to mend splits or loose joints in the wooden support
- ***Consolidation*** to reattach loose paint to its support with appropriate adhesive
- ***Facing***, or attaching tissue to the paint with a suitable adhesive. Facing is a protective measure that holds flaking paint in place until the painting can be treated.
- ***Lining***, or attaching a new piece of fabric or other support material to the back of the original canvas to reinforce it, thus preventing loss that can occur due to a painting's structural weaknesses.
- ***Removing old repairs***, such as removing patches and tape from the back of a canvas or old cradles on panel paintings that are contributing to a painting's deterioration.

4. *What might conservators do to restore my painting?*

Conservators will choose from among hundreds of restoration techniques, depending on your painting's condition. Restoration includes:

- ***Cleaning***: This involves removing surface dirt and usually involves removing the varnish. Cleaning methods are chosen based on the type of paint and varnish used on a painting.
- ***Filling***: This includes filling any losses to the ground layer.
- ***Inpainting***: This involves painting in areas of paint loss or new fills so they are not obvious. Inpainting is done for aesthetic reasons, so that losses don't detract from the painting's overall appearance. Conservators will usually choose paints that can be easily removed so that future conservation treatments won't have to include difficult paint removal.
- ***Removing old paint***: This involves removing paint from past "restoration" treatments. Restorers often painted on top of the original paint, known as "overpainting."
- ***Transfer***: This is an extreme treatment that involves moving the image layers to a new support. This is done only if the existing support is contributing to the image layer's decay. This is a complicated procedure that involves removing the support from the back of a painting.

H. Procedures for Handling Paintings During Emergencies

Chapter 10: Emergency Planning, gives information about planning for emergencies and minimizing damage. This section gives specific information on caring for paintings damaged in an emergency.

1. *In what ways can a disaster affect my paintings?*

Unfortunately, accidents and natural disasters occur and cause damage to museum collections. For paintings, water damage is very serious and requires immediate treatment. Water causes wood to swell, creating instant pressure on panels and stretchers. Water can also dissolve sizing, causing the image layer to separate from the support.

Other accidents and disasters can leave torn, burned, sooty, or muddied paintings. In these cases, the damage to the paintings has already occurred. Contact a conservator immediately. Don't attempt to clean mud, dirt, or soot or to mend a ripped painting. You can increase the damage to the painting.

Fire can blister the paint layers. Never try to press the paint back down into place. A trained conservator will usually apply heat to flatten the blisters before attempting to clean the painting, which is a very delicate procedure.

2. *What do I do if my paintings are water damaged?*

Act quickly. Water can seriously damage paintings in a matter of minutes. Immediately contact a conservator if one is available. If not, salvage your collection in order of priority identified in your park's disaster plan. Salvage paintings that have the highest value in your collection first.

- **Remove frames.** Don't remove canvas from stretchers.
- **Remove excess water** by gently tilting each painting to let the water run off the surface.
- **Set up a work area where there is no danger of further damage.** Paintings with flaking layers should be dried face-up on a table, and should not be touched.
- **Keep wet paintings horizontal** and paint side up.
- **Place fans around the work area** to increase circulation and decrease drying time.
- **Use dehumidifiers** to assist in the drying process. Maintain a RH of 60% to 70% to avoid over drying.

3. *What should I do in the case of an emergency that is NOT water-related?*

In most cases the damage will already be done, so there is no need to rush as you would in the case of water damage. However, be aware that some damage, like rips and tears, usually become worse over time.

- **Don't touch anything**, if possible.
- **Contact a conservator** as soon as you can.
- **Contact your regional/SO curator** for additional technical assistance.

- *Move the paintings only enough to be sure they are not in a vulnerable position that could cause further damage*, such as perched at the edge of a table or hanging crookedly on the wall.
- *Remove anything that may have fallen onto your paintings.*

I. Glossary of Terms Used for Condition Reporting When Examining Paintings*

Blanching: irregular, obtrusive, pale or milky areas in paint or varnish; not a superficial defect like **bloom** but a general scattering of light from increased porosity or granulation in aged films

Blister: a separation between layers appears as an enclosed, bubbled area

Bloom: a whitish, cloudy appearance in the varnish layer caused by exposure to moisture or resulting from deterioration of wax-based media; sometimes called efflorescence

Buckling: waves or large bulges in a canvas from non-uniform tension around the stretcher or strainer

Chalking: loss of a paint or emulsion layer by powdering off

Check: splitting of wood along the grain, from the edge of a board or panel for a part of its length; usually in response to repeated dimensional change brought on by fluctuations of temperature and humidity

Cleavage: a separation between the paint layers and the support producing tenting (gable-like ridges) or cupping (concave flakes); caused by the contraction of the support, forcing the paint layer up off the surface

Crackle: a network of fine cracks; also found in other materials such as lacquer, and glazed ceramics

Crazing: a fine system of crackling in a varnish layer, usually found in aged films in the final stages of drying and embrittlement

Cupping: see *cleavage*

Dishing: a defect in the stretcher caused by the torque of a drawn fabric; if the stretcher members are twisted out of a common plane, a shallow angle is formed at the corners

Draw: a local distortion at the corner of a painting, marked by diagonal cockling from the corner toward the center of the mount

Fill: the material used to replace areas of loss; fill is then inpainted

Flaking: lifting and sometimes loss of flat areas of the surface layer

Inpainting: new areas of paint to restore design or color continuity; restricted to areas of loss

Overpainting: areas of repainting over existing original paint

Split: a rupture running along the grain of a piece of wood from end to end, usually caused by exterior mechanical stress

Stretcher crease: a crease or line of cracks in the ground and paint layers of a painting on fabric, following the inside edges of stretcher members or the edges of cross-members; caused by the flexing of the fabric against the edges of these members

Tenting: see cleavage

Warp: in a panel, the planar deformation of the support caused by changes in relative humidity

Wrinkling: small ridges and furrows of crawling paint or varnish caused by improper methods or materials

*Terms taken from Demeroukas, 1998

J. Selected World Wide Web References

American Institute for Conservation leaflet, "Caring for Your Paintings": <<http://aic.stanford.edu/treasure/paint.html>>.

American Institute for Conservation Disaster Recovery Page: <<http://palimpsest.stanford.edu/aic/disaster/>>.

Conservation OnLine, Resources for Conservation Professionals: <<http://palimpsest.stanford.edu>>.

Conserve O Gram leaflets: <<http://www.cr.nps.gov/csd/publications/index.htm>>.

K. Selected References

Bachmann, Konstanze, ed. *Conservation Concerns: A Guide for Collectors and Curators*. Washington, D.C.: Smithsonian Institution Press, 1992.

Bomford, David. "Conservation and Storage: Easel Paintings." In *Manual of Curatorship*. London: Butterworths, 1984.

Canadian Conservation Institute. *CCI-ICC Notes*. Ottawa, Ontario: Canadian Conservation Institute.

10/1, "Cleaning Paintings: Precautions." 1995.

10/2, "Making Padded Blocks." 1995.

10/3, "Storage and Display Guidelines for Paintings." 1993.

10/4, "Environmental and Display Guidelines for Paintings." 1993.

10/5, "Emergency Treatment of Water-Damaged Paintings on Canvas." 1997.

10/6, "Condition Reporting—Paintings. Part I: Introduction." 1993.

10/7, "Condition Reporting—Paintings. Part II: Examination Techniques and a Checklist." 1993.

10/8, "Framing a Painting." 1993.

10/9, "Keying Out of Paintings." 1993.

- 10/10, "Backing Boards for Paintings on Canvas." 1993.
- 10/11, "Condition Reporting – Paintings. Part III: Glossary of Terms." 1994.
- 10/12, "Removing a Painting from Its Frame." 1993.
- 10/13, "Basic Handling of Paintings." 1993.
- 10/14, "Care of Paintings on Ivory, Metal, and Glass." 1993.
- 10/15, "Paintings: Considerations Prior to Travel." 1993.
- Demeroukas, Marie. "Collections Management: Condition Reporting." In *The New Museum Registration Methods*. Washington, D.C.: American Association of Museums, 1998.
- Feller, Robert L., et al. *On Picture Varnishes and Their Solvents*. Washington, D.C.: National Gallery of Art, 1971.
- Hunter, John E. *Fabricating Secure Hangers for Framed Works of Art*. NPS Conserve O Gram 2/7. Washington, D.C.: National Park Service, 1994.
- Keck, Caroline K. *A Handbook on the Care of Paintings*. Nashville, Tenn.: American Association for State and Local History, 1965.
- Knapp, Anthony M., and Pam West. *Storage Screens for Paintings*. NPS Conserve O Gram 12/1. Washington, D.C.: National Park Service, 1993.
- Leisher, William R. "Paintings." In *Caring for your Collections*. Washington, D.C.: National Committee to Save America's Cultural Collections, Arthur W. Schultz, Chairman, 1992.
- Raphael, Toby. *Exhibit Conservation Guidelines: Incorporating Conservation into the Exhibit Process*. Harpers Ferry, W.V.: National Park Service, Harpers Ferry Center – Division of Conservation. CD-ROM.
- Sandwith, Hermione, and Sheila Stainton. *The National Trust Manual of Housekeeping*. London: Penguin Books Ltd. and the National Trust, 1984.
- Shelley, Marjorie. *The Care and Handling of Art Objects*. New York: The Metropolitan Museum of Art, 1987.
- Stout, George L. *The Care of Pictures*. New York: Dover Publications, Inc., 1975.

Appendix M: Management of Cellulose Nitrate and Cellulose Ester Film

	<u>Page</u>
A. Overview	M:1
What is cellulose nitrate (nitrate)?.....	M:1
What are nitrate photographic negatives and transparencies?	M:2
What is nitrate motion picture film?	M:2
When was nitrate used in the United States?.....	M:3
Why should I be concerned about nitrate film?.....	M:4
What values do nitrate films have for parks?	M:6
B. Identification and Evaluation of Historical Nitrate and Cellulose Ester Film	M:8
What transparent flexible film bases have been produced?.....	M:8
Does cellulose ester film deteriorate?	M:9
What is the vinegar syndrome?	M:9
What does deteriorated cellulose acetate, diacetate, and triacetate film look like?.....	M:10
How do I identify nitrate materials?	M:10
How do I determine whether film is nitrate, cellulose ester (acetate, diacetate, triacetate) or polyester?	M:12
How do I use the polarization test?	M:12
How do I use the burn test?	M:13
How do I use the float test?	M:13
How do I use the diphenylamine test?	M:14
What determines the speed of nitrate deterioration?	M:14
Is nitrate deterioration predictable?	M:15
What are the stages of nitrate deterioration?.....	M:15
What chemical tests can be used to predict whether nitrate life has been exceeded?.....	M:17
What tests can be used to predict the life of cellulose ester films?.....	M:17
How do I ensure the long life of cellulose ester films?	M:17
Where can I get help on these issues of nitrate and cellulose ester identification and deterioration analysis?.....	M:18
C. Management of Nitrate and Cellulose Ester Films	M:18
Do I have to keep nitrate film?	M:18
Do I have to keep other deteriorating film types, such as cellulose acetate, diacetate, and triacetate?	M:19
What special storage requirements must my facility meet?	M:19
What other options do I have if I don't want to store film in my park?.....	M:20
How should I manage nitrate that I keep in the park on a short- or long-term basis?.....	M:21
Should I isolate and handle cellulose acetate, diacetate, and triacetate in the same way?.....	M:23
What should I do when working with nitrate to avoid health hazards?.....	M:23
How do I avoid health hazards with cellulose ester films?	M:24
How should I mark nitrate and cellulose ester films?	M:24
What common factors affect the life expectancy of nitrate and cellulose ester films?	M:25
What materials and systems should I use to house my nitrate and cellulose ester?.....	M:26
How should I prepare my collections for cold storage?.....	M:27
How should I clean dirty films?	M:27
How should I reformat my nitrate, and cellulose acetate, diacetate, and triacetate?.....	M:27
How should I inspect reformatted nitrate that has been returned?	M:29
Do I have to deaccession reformatted nitrate negatives?	M:31
Can I destroy reformatted nitrate negatives?.....	M:31
How do I document reformatted nitrate negatives?	M:31
How do I dispose of nitrate?	M:30
When should I keep original nitrate?	M:31

How do I train my staff to handle, house, store, and manage nitrate and cellulose ester film?.....M:31
How should I answer requests for access to nitrate?M:31

D. Prevention of Nitrate Fires.....M:31
What causes nitrate fires?.....M:31
How do I prevent a nitrate fire?M:32
At what temperatures are nitrate materials dangerous?M:33
What materials pose the greatest risk of causing a nitrate fire?M:35
What nitrate materials pose the least risk of causing a nitrate fire?M:34
What should I do in case of a nitrate fire?.....M:34
What nitrate fires have occurred recently?.....M:36
What do I do if my nitrate or cellulose ester becomes wet during fire fighting or cold storage?M:35

E. Bibliography.....M:35

List of Figures

Figure M.1. National Fire Protection Agency Hazard Warning Sign for Cellulose Nitrate FilmM:21

Appendix M: Management of Cellulose Nitrate and Ester Film

A. Overview

1. *What is cellulose nitrate (nitrate)?*

Nitrate refers to a group of early transparent plastic film supports that were most common between 1910 and 1950. Created as an easy-to-handle replacement for heavy and awkward glass plates, gelatin film, and paper negatives, nitrate film was used for still photographic negatives and transparencies, as well as motion picture film. Most nitrate film consists of a flexible sheet or roll of cellulose nitrate (nitrate) film base with a silver gelatin photographic emulsion (image bearing layer) on top. During the 20th century, amateur and professional photographers and filmmakers used nitrate more frequently than any other film support to hold the emulsions of their negative and film images.

Cellulose nitrate polymers, initially called gun cotton, were first synthesized over 150 years ago for use in the manufacture of military explosives. Later, cellulose nitrate polymers were treated with camphor to produce some of the earliest plastics. Celluloid, an early plastic replacement for ivory, was made into hairbrushes, billiard balls, toys, and a variety of home products. In the late 1940s, cellulose nitrate lacquers, adhesives, and metal coatings became popular, many of which are still in common use today. More recently, printing inks; plastics; coatings for stone, metal, and ceramics; and common adhesives, such as DUCO Cement and UHU All Purpose Clear Adhesive, have used cellulose nitrate polymers. Cellulose nitrate polymers vary in the amount of actual cellulose nitrate in their composition, from collodion photographic emulsions with a 10.5% concentration, to photographic flexible film bases with a 12% concentration, to explosive weapons-grade gun cotton with a 12.5% concentration.

If deteriorated, nitrate may be yellowed, tannish, stained, bleached, sticky, brittle, blistered, pungent-smelling, or powdery, depending upon the stage of deterioration. Nitrate photographic film has sometimes been called:

- celluloid
- nitrocellulose
- flammable film
- pyroxolin
- flam film
- cellulose nitrate

Nitrate is often confused with the cellulose ester films, including acetate, diacetate, and triacetate negatives, which deteriorate in a similar fashion. Cellulose ester films are described in Section B.1. Paper-based photographs are **never** nitrate. Specific tests have been developed to identify nitrate.

See Section B.6 below for more information on these tests. The modern replacement for nitrate and acetate films is polyester, a stable plastic.

2. *What are nitrate photographic negatives and transparencies?*

In the United States, nitrate-based still photographic negatives and, less commonly, positive transparencies were produced between 1889-1950. Both amateur and professional photographers used nitrate film for fine art photography, photojournalism, portraits, travel photography, and technical photography such as aerial, dental, legal, and medical photographs (both X-ray and standard negative and transparency images). Manufacturers such as Agfa, Ansco, Defender, DuPont, Hammer, and Kodak produced nitrate films. See Table 1 (Section A.4) to learn when different formats and types of nitrate still negatives were first introduced or last available in the U.S.

The earliest nitrate film (1889-1903) has a thin (<8/1000 of an inch or <8 mil) nitrate film base and gelatin coating on only one side; therefore it tends to curl. This earlier film is more stable than later professional film, which has a thicker nitrate base (8 mil) to keep the film flat during processing. Professional negatives are the least stable of the still negatives. On occasion, rolls of 35mm-nitrate still negative film are confused with motion picture film when the roll film remains in its original roll format. Roll films may be identified by their frame numbers, which motion picture films lack. Nitrate sheet and cut film have a border pattern (frame-like edge) that doesn't occur consistently around the image. On the long edge of the film, the border ends about an inch from the end of the image, while the image reaches to the film edge in this area.

Most nitrate still images are flat sheets of transparent flexible film containing negative or positive photographic images in a wide variety of sizes (formats) from 35mm to greater than 16" x 20". Included in this category are:

- *aerial film* (ranging in size from 4" x 5" to 8" x 10"), which is easily identifiable by subject content
- *X-ray film* (emulsion coated on both sides of the base), which is also easily identifiable by subject content
- *film packs* (up to 5" x 7"), which are recognizable by the lightweight film base, a wide short-edge border (frame-like edge of the image) and thinner long-edge border, and the adhesive or paper residue from a pull tab that may be present on the short border.

3. *What is nitrate motion picture film?*

Nitrate motion picture film consists of varying length strips of flexible film with perforations along both side edges, which allow the film to be fed through a camera, projector, or film editor. Unlike slides and negative roll film, however, the motion picture film frames have no sequential frame numbers. Nitrate motion picture film was used to create educational film strips, amateur films, training films, travel films, and amateur and commercial motion picture releases, both silent and with sound.

Nitrate motion picture film can contain positive or negative motion picture images. These images may be either color or black and white, generally showing motion in sequence from left to right like a comic strip. Most nitrate motion picture film is thinner than negative film but relatively less stable as it is stored tightly rolled and in large quantities, which hastens deterioration.

Nitrate motion picture film was originally available between 1895 and 1951. These nitrate motion picture film availability dates are not absolute, however, as some filmmakers had stockpiles of this film and continued to use it for some years. See Table 1 below for precise dates when specific types of nitrate stopped being manufactured in the U.S.

4. *When was nitrate used in the United States?*

American amateur and commercial still photographers used nitrate-based film most frequently between about 1908-1939, although nitrate film was available between 1889 and 1951. Specific dates vary for some gauges and formats (X-ray, aerial film, and roll film). The history of nitrate and other film types produced in the U.S. is chronicled below.

Table 1: A History of Nitrate Film	
1889	Nitrate film is developed for roll film (not 35mm), sheet film, film pack film, X-ray film, and professional 35mm motion picture film.
1895	Nitrate commercial motion picture film is available.
1900	Nitrate motion picture film becomes commonly available.
1903	Nitrate film is given a thicker nitrate film base and a gelatin backing on both sides.
1908	Kodak introduces cellulose acetate “safety” roll film negatives for still cameras.
1909	The National Board of Fire Underwriters develops rules for nitrate handling and storage.
1920	Nitrate 35mm roll film and aerial film are available.
1920	Acetate amateur motion picture film is available in 8mm and 16mm formats.
1920	Nitrate negative film commonly replaces glass plate negatives.
1923	Kodak introduces cellulose acetate amateur motion picture film.
1925	35mm nitrate still negative film begins to be available and cellulose acetate film becomes much more common.
1930	Acetate sheet film, X-ray film, and 35mm roll film become available.
1933	Last year Kodak manufactures nitrate X-ray film in the U.S.
1935	Nitrate still negative film begins to be replaced by cellulose acetate “safety” film.
1937	Cellulose acetate film begins to be replaced by cellulose diacetate.
1938	Last year Kodak manufactures 35mm nitrate still negative roll film in the U.S.
1939	Nitrate still negative film is largely replaced by “safety” films.
1939	Last year Kodak manufactures portrait and commercial sheet nitrate film.
1940	Acetate aerial film and roll film (other than 35mm) is developed.
1942	Last year Kodak manufactures aerial nitrate film in the U.S.
1947	Cellulose diacetate still negative film begins to be replaced by cellulose triacetate.
1948	Kodak introduces triacetate motion picture films. <i>Note:</i> If your print is edge marked “safety,” it dates after 1948.
1949	Triacetate motion picture films are now in common use.

1949 – Last year Kodak manufactures nitrate film packs in the U.S.

1950 – Last year Kodak manufactures roll film in sizes 616, 620, and 828 in the U.S.

1950 – Acetate film pack and professional 35mm motion picture film become available.

1951 – Last year Kodak manufactures professional 35mm motion picture film in the U.S.

1951 – After this date, all camera negative separation films (Technicolor camera negatives, master positives, matrices, and release prints) are produced in triacetate. Most film produced before this date in the U.S. is unstable.

1960 – Polyester sheet film, X-ray film, and aerial film become available.

1960s– During this decade, most Technicolor™ films are on polyester support matrix films.

5. *Why should I be concerned about nitrate film?*

As it deteriorates, nitrate gives off highly acidic nitrogen oxide gases, particularly nitric oxide, nitrogen dioxide, and others, which either escape into nearby areas—threatening staff, buildings, and collections—or stay captured in the sealed storage area. Unless allowed to escape, these gases build up, causing an autocatalytic reaction that speeds decomposition of the original nitrate materials. Since the reaction produces heat, which further acts on the available gases and humidity, the environment around the nitrate rapidly becomes toxic. Nitrate poses a variety of problems, including:

- **Health problems:** All nitrate film deteriorates naturally over time, unless kept in very cold storage. Deteriorating nitrate film gives off gaseous byproducts, including nitrate oxide and nitrogen dioxide gases, which may threaten researcher and staff health. Health threats include:
 - eye irritation
 - headaches
 - nausea
 - rashes
 - respiratory irritation
 - skin irritation
 - swollen glands
 - vertigo

All human exposure to nitrate should be limited in duration and monitored for side effects. Staff working with nitrate must keep track of and limit the number of hours of exposure and use special equipment when working with nitrate. See Section C.7 for details.

- **Safety problem:** As nitrate decomposes, it releases heat (an exothermic reaction) and acidic gases, including nitric oxide and nitrogen dioxide. In the presence of high humidity or water vapor, the nitrogen dioxide deterioration byproducts can produce nitric acid, a very corrosive compound. Large quantities of nitrate, particularly bulk quantities of roll

film (20,000 linear feet or more), motion picture (20 films or more), or X-ray film (875 X-rays or more than 75 pounds), when housed together, will deteriorate at an ever-accelerating rate due to the build up of heat and acidic gas deterioration byproducts. See Section C.7 for guidance on how to work with nitrate.

If you store quantities of deteriorated nitrate, it may spontaneously ignite at temperatures of 100°F (38°C) or higher. Undeteriorated nitrate ignites at about 266°F (130°C). **Burning nitrate produces toxic gases, such as carbon monoxide and nitrogen peroxide that pose a severe threat to life.** These toxic gases have killed many individuals in theaters, clinics, and storage structures. In 1929, gases from burning X-rays during a clinic fire in Cleveland killed 125 people.

Since nitrate contains chemically combined oxygen, it produces its own oxygen as it burns. Once burning, nitrate roll film or motion picture film is almost impossible to extinguish as the center of the film burns at the same speed as the exterior due to the nitrate's ability to use the chemically combined oxygen. Nitrate is a serious threat to the safety of all people that work in the same building, all collections stored in the building, and all historic structures nearby. Nitrate can burn in a closed film can, under water or sand, and despite modern fire suppression systems including dry chemical and foam fire extinguishers, halon, carbon dioxide fire systems, and similar extinguishers. See Section D for guidance on how to avoid nitrate fires. Nitrate can also suffer from the standard deterioration problems of film, such as mold, insect infestations, and vermin infestations, all of which pose additional health hazards. See *Museum Handbook*, Part II, Appendix R: Curatorial Care of Photographic Collections.

- **Structural safety problems:** As well as being toxic, nitrate fires are known for their intensity and explosive force. Nitrate burns at a combustion rate 15 times greater than that of wood. While burning, nitrate produces toxic and flammable gases—including carbon monoxide and nitrogen peroxide.

Just five pounds of nitrate (1 reel of motion picture film or 125 negatives larger than 4" x 5" in size) can release over 25 cubic feet of carbon monoxide. These gases are produced at such a rate that they place tremendous pressures on building structures, frequently leading to structural collapse. Nitrate fires usually burn until all fuel is consumed, often accompanied by explosions.

- **Collection problems:** As it deteriorates, nitrate gives off gases that deteriorate other materials, such as paper, leather, fabric, and wood, as well as stone and some metals. The nitric acid created as the result of nitrate deterioration corrodes metal, makes gelatin binders (part of the film image-bearing emulsion) sticky, and fades silver images. Even when in refrigerators or freezers, nitrate should not be housed in general museum or archival storage areas, work spaces, or general office spaces for more than five years) as some fumes are still given off. Nitrate is a threat to the survival of collections housed in the same or nearby buildings. See Sections C.11 and C.12 for guidance on how to house and store nitrate.

6. *What values do nitrate films have for parks?*

Nitrate negatives and motion picture film forms the largest portion of the visual record of the early 20th century. This material has value for a wide variety of purposes, including:

- **Informational value:** Nitrate film provides meaningful data and information essential for tracking how parks have changed over time including:
 - activities and events
 - archeological sites
 - buildings and restoration of structures
 - geology
 - historic landscapes and vegetation
 - human impact on ecosystems and fauna

Nitrate captures the ephemeral, transforming it into a record that can be interpreted, evaluated, utilized as data, and transformed into information and knowledge. Don't lose this information through neglect or disposition. High quality copies can have almost as much informational value as original nitrate. If you have a high quality copy, such as an interpositive copy or a duplicate negative in good condition, you don't have to keep the original negative if it has only informational value.

- **Artifactual value:** Materials that are rare, interesting, or outstanding examples of photography or filmmaking have artifactual value. Some nitrate negatives, for example, such as those by Ansel Adams, Lewis Hine, or Carleton Eugene Watkins, are important artifacts in their own right because of their excellence as visual objects.

Nitrate with high artifactual value will generally have some of the following characteristics:

- fine composition
- sharp focus/resolution (unless purposefully impressionistic)
- good tonal values
- excellent depth of field (clear focus and image depth in both foreground and background areas)
- lack of obvious blemishes such as smudges and dust spots
- representation of the subject matter in a visually arresting, interesting, or surprising way
- good contrast (clear bright highlights and deep dark shadow areas)

- good range of clear details, even in the dark shadow and bright highlight areas

These high artifactual value nitrate materials must be preserved as major assets until they become so deteriorated that they have lost their functionality and become a threat to other materials. Poorly composed, unfocused, and muddy images would not qualify as having high artifactual value. Generally speaking, high quality copies **don't** capture all the artifactual value of an original photograph. Copy and keep undeteriorated original nitrate that has high artifactual value.

- **Evidential value:** Some nitrate negatives serve as either legal or historical proof of an activity, event, occupation, or action, such as law enforcement footage of an illegal activity. The state and federal laws have specific requirements for how evidential materials must be maintained prior to a court case. Such legal requirements might include:
 - an unmanipulated image that has not been dodged, burned, retouched, tinted, or airbrushed, either in the darkroom or afterwards
 - documentation on when, where, how, why, and by whom the image was taken and what it documents
 - a record of a continuous chain of custody by the creator (photographer or his or her employer)

This evidential nitrate should be kept for its value as legal and historical evidence, although while still active, it is unlikely to be found in museum collections. Legal records may eventually become unnecessary; however, **historical proof is always necessary**. Nitrate film that serves as historical or legal proof must be copied with particular care to ensure that it doesn't lose its usefulness as evidence. You may need to consult with a lawyer or historian before disposing of these legal or historically evidential materials, even after copying. In some cases you may be bound to maintain the original in perpetuity, or at least until it is deteriorated beyond stage 3. See Section B.13 for a description of the stages of deterioration. Copy and keep this original nitrate film. Consult your solicitor for guidance on preserving the evidential value of the original in your copy.

- **Associational value:** Some nitrate has importance for its relationship to a notable individual, group, event, place, or activity, such as the images taken by or of presidential family members, famous authors, famous generals, or other notables. Associations might include:
 - an individual or group who created, owned, or was shown in the image, such as Franklin D. Roosevelt
 - an activity, such as a parade, staff-training, or a celebration
 - a movement, such as Suffrage, Emancipation, or Impressionism
 - a geographical locale, such as a particular park site

- an era or event documented, such as the Spanish-American War or Inaugural Day

Generally speaking, associations are more powerful for original materials than with copies. Maintaining the original nitrate will maintain that direct link to the associated individual or group. Copy and keep undeteriorated original nitrate with high associational value.

- **Administrative value:** Some nitrate is essential for the day-to-day operation of the parks. This includes nitrate film that documents museum collections; nitrate film used as resource materials for park publications; and nitrate film that serves as documentation of land boundaries, flooding, or forest fire damage. Generally speaking, these materials eventually become part of the park museum collections because of their informational content, if, for example, they contain baseline data on ecosystems. These materials, once copied, inspected, deteriorated, and deaccessioned may be disposed of as NPS hazardous waste according to Environmental Protection Agency (EPA) guidelines. Work with a NPS hazardous waste coordinator. See C.16 and C.17.

B. Identification and Evaluation of Historical Nitrate and Cellulose Ester Film

1. *What transparent flexible film bases have been produced?*

During the late 19th and early 20th century, there were a number of transparent film bases created, including:

- **Cellulose nitrate (nitrate):** Described in Section A.1.
- **Cellulose ester (acetate) family of safety film bases:** The cellulose ester family of film bases is usually referred to as triacetate, diacetate, or acetate or is simply called safety film. Though developed to be permanent film bases, unfortunately these films were no more stable than nitrate. Their maximum life expectancy (LE) is 100 years at an average room temperature of 70°F. The major difference between the nitrate and cellulose ester family of film bases is that the cellulose ester films are **not** as flammable. Because of the presence of acidic decomposition byproducts, these cellulose ester film types should be isolated, reformatted, and placed in cold storage as they deteriorate. **Most 20th century color film (slides and negatives) is cellulose ester, even film and transparencies being produced today.** Manufacturers such as Agfa, Ansco, Defender, DuPont, Hammer, and Kodak have produced or are producing cellulose ester films. See Sections B.2-B.4, and B.6.
- **Cellulose acetate (acetate, cellulose acetate propionate, and cellulose acetate butyrate):** Developed about 1935, these were the first of the “safety” cellulose film types used to replace nitrate. The major improvement over nitrate was an ignition temperature above 800° F.

- **Cellulose diacetate (diacetate):** This is the second of the safety cellulose film types, used to replace nitrate film and acetate around 1937. Like acetate, diacetate is no longer-lived than nitrate. Diacetate films discolor, shrink, and become progressively more brittle over time. Storage environment, particularly temperature and humidity, greatly affects the life of this film. Cellulose diacetate began to be replaced by triacetate in 1948.
- **Cellulose triacetate (triacetate):** This is the last of the cellulose ester films that replaced nitrate around the 1950s. It was first available in 1948 as motion picture film and commonly in use by 1949. As early as 1960, reports began to filter in that cellulose triacetate film was not permanent when stored under warm and humid conditions.
- **Polyester (polyethylene terephthalate):** This refers to a clear neutral plastic film used for film bases since the 1950s. Polyester is a long-lived and durable film base. Films marked “Estar” or “Cronar” are polyester. Manufacturers such as Agfa, Ansco, Dupont, and Kodak produce or have produced polyester films. Polyester is not particularly flammable, does **not** give off dangerous gases, and has a maximum life expectancy (LE) of 500 years.

2. *Does cellulose ester film deteriorate?*

Yes. All flexible films in use before 1950 deteriorate. As cellulose ester films age, deterioration lowers the pH of the cellulose ester’s emulsions (image-bearing layer), causing fading and film-base deterioration. Like nitrate, these films become brittle as they age. Cellulose ester film may develop crystals or bubbles on the emulsion surface of the images.

The classic cellulose ester deterioration patterns are “channeling,” in which the film image layer (emulsion) forms raised blisters and tunnels on the film base and “vinegar syndrome,” described in Section B.3 below. Ultimately, the only effective preservation solutions are reformatting and inspection of the original, followed by cold storage of any undeteriorated originals of continuing value. For more guidance and a rating system for comparing the various types of value, use, and risk, see *Conserve O Gram (COG) 19/10*, “Reformatting for Preservation and Access: Prioritizing Materials for Duplication.”

3. *What is the vinegar syndrome?*

As the cellulose ester films (acetate, diacetate, and triacetate) deteriorate, they chemically decompose, producing acetic acid. Acetic acid is the cause of the well-known “vinegar” smell frequently noted around collections of acetate, diacetate, and triacetate. Like nitrate, the decomposition is autocatalytic, meaning that the presence of acidic decomposition byproducts near the original film will speed further decomposition. Using sealed or closed containers hastens this deterioration process by maintaining deterioration byproducts and acetic acid gases next to the film. Like nitrate films, cellulose ester films should be isolated for cold storage. Handle cellulose ester film carefully, as acidic gas byproduct build-up near the film can also be a health hazard.

4. *What does deteriorated cellulose acetate, diacetate, and triacetate film look like?*

Most cellulose ester film types deteriorate in the following characteristic ways:

- *slight film curl* (*Note:* This is also exhibited by nitrate from the 1889-1903 era)
- *vinegar-like or acetic acid smell*, which grows stronger as the film deteriorates
- *film shrinkage*, which can change the film's dimensions
- *film embrittlement*, although it doesn't turn amber-colored like nitrate
- *some warping and planar distortion*, so that the film is no longer flat, but instead has raised areas
- *bubbles* in the film emulsion
- *channels of raised film emulsion* on the film surface (as the film emulsion separates or lifts from the film base it produces channels, tunnels, and large blister-like features)
- *silvering-out* or metallic mirroring or image tarnishing that begins to occur in the densest image areas

Note: Only nitrate has rainbow effects that appear in the darkest and most silvered-out areas of the image. Acetate, diacetate, and triacetate films lose image detail and look dark and reflective when they silver-out; they don't have rainbow-like-patterns.

5. *How do I identify nitrate materials?*

There are several ways to identify nitrate materials, including:

- ***By date of manufacture:*** Table 1 in Section A.4 provides a review of the dates during which various types and format of film were most commonly used. Most film negatives and motion picture film made in the United States before 1951 are suspect as being potentially nitrate. Additionally some negatives and films made in France during World War II were nitrate.
- ***By internal evidence:*** Internal evidence is the best way to identify nitrate. There are several common types of internal evidence, including:
 - ***Edge markings:*** Edge markings or edge prints are actual words on the borders of film that indicate the film name or type. Some manufacturers edge-marked their nitrate film with the word "nitrate," while they marked other film with specific brand names or types of nitrate film, such as "Eastman Nitrate Film." **If** you are dealing with an original negative, you can depend upon the "nitrate" edge marking. *Note:* The marking "safety film" indicates that the film is cellulose ester (acetate, diacetate, or triacetate), while films marked "Estar" and "Cronar" are polyester.

Occasionally, when copying nitrate film to a safety base the nitrate edge markings also were copied. These copies of nitrate on safety base would have both “nitrate” and “safety” edge markings, thus alerting you to their “safety” status. So, the presence of the word “nitrate” as an edge marking is **not** conclusive proof that the material is nitrate if you are dealing with a copy image. Look for V-shaped notch codes (punches taken out of an image border in a particular configuration to indicate the film type to photographers working in a darkroom) in addition to the word “nitrate” for more conclusive proof that the image is nitrate (see notch codes below). Your best use of edge markings is to look for the word “safety.” Assume that pre-1950 film or negatives not marked with the word “safety” are nitrate. Also assume that unmarked film produced prior to 1950 is nitrate, until you can test it.

Flexible film-based negatives (not glass, paper, or metal based negatives) and motion picture film produced between 1890-1950, which don't have the words “safety film” marked on them, generally are nitrate. Use this distinction as one easy way to identify nitrate.

- ***Notch codes:*** Notch codes are small punches taken out of the border of nitrate, developed to help photographers identify the film type in the dark room. These codes varied over time by manufacturer, process, and format of film. Kodak “V” notch codes, used in combinations of up to three notches, designated that the film was nitrate. When the earliest safety film appeared, the outermost notch became a rectangular “U.” After 1949, Kodak reused the old “V” notch codes for safety film. Notch codes provide uncertain guidance and are best used in conjunction with other internal evidence.
- ***Odor:*** Nitrate film has a pungent nitric acid smell as it deteriorates and may have a camphor-like odor when it burns. These odors should not be confused with the vinegar-like acetic acid smell of deteriorating acetate, diacetate, and triacetate safety film.
- ***Yellowish-brown base color:*** As it deteriorates, nitrate film changes in color from clear and transparent to a distinctive dark amber tone. To determine if the base has this tone, look along the border or edge of the film where there is no emulsion or cut a small chip from the edge of the film and place the film chip in water. After about 15 minutes, when the emulsion has softened, scrape it to see if the film is amber in color. If it is, the film is probably nitrate.
- ***Base brittleness:*** Deteriorated nitrate is very brittle. You may cut a tiny chip off the border of a piece of nitrate film and try bending it. Compare the film’s resilience to that of a piece of contemporary film by flexing it gently. Nitrate will be significantly more brittle.
- ***Emulsion stickiness:*** Check the image’s emulsion border for stickiness. Emulsions on nitrate that has reached stage 2 of deterioration or higher may be sticky or softened. (See B.13 for a review of nitrate deterioration stages.)

- **Emulsion mirroring or silvering out:** Both nitrate and acetate film turn mirror-like or look like tarnished silver—usually in the densest image areas. However, in nitrate the mirroring may appear as a black rainbow, while in acetate there is no rainbow-effect.
- **Emulsion cockling and buckling:** As it deteriorates, nitrate shrinks. This shrinkage causes the negative emulsion to buckle and lift-off the cellulose nitrate base. Early safety film (acetate, diacetate, and triacetate) also has an emulsion shrinkage problem that causes the emulsion to separate from the base and form long web-like channels. Channelized film, in which the emulsion lifts off the base to form raised honeycomb-like cells or tunnels, is **always** cellulose ester.
- **Film gauge:** Though motion picture film has come in a wide variety of gauges, nitrate was not available in all of them:
 - standard 8mm (never made in nitrate)
 - super 8mm (never made in nitrate)
 - 16mm (never made in nitrate)
 - 35mm (the most common nitrate gauge)
 - 70mm (less common nitrate gauge than 35mm)

Use the internal evidence indicators above with care, as they may be inconclusive. You may need to test the material to determine if it is nitrate

6. *How do I determine whether film is nitrate, cellulose ester (acetate, diacetate, triacetate) or polyester?*

You can use any of four tests to determine the composition of photographic negatives, transparencies, or motion picture film in your collection:

- **The polarization test** identifies polyester film.
- **The burn test** identifies nitrate film.
- **The float test** identifies all film types.
- **The diphenylamine test** identifies nitrate film.

Before using these tests, attempt to identify the nitrate by one of the techniques described in Section B.4 above. Or, use the polarization test (see Section B.7) in conjunction with the techniques described in B.4. While each of the four film tests has particular advantages and disadvantages as described below, **only the polarization test is non-destructive**. Therefore, the polarization test is the preferred test for use with NPS museum collections. Don't try to undertake the destructive tests (burn test, float test, or diphenylamine test) without training and appropriate facilities, such as fume hoods or an acid/organic vapor cartridge breathing apparatus that has been fitted to the user.

7. *How do I use the polarization test?*

The polarization tests can help you determine if film is made out of polyester. Place the film to be tested between two photographic polarizing filters or two pairs of polarized sunglasses. Twist or “cross” the filters or glasses so that they allow light to pass through them. Project a strong light through the pair of “crossed” polarized filters (or polarized sunglasses) and film. If the film is

polyester-based, the shimmering full spectrum of rainbow-like patches will appear on the film. If the film is one of the cellulose esters or nitrate, you will simply see dimmed light, but no rainbows. As the only non-consumptive film test, **the polarization test is preferred over the other testing options.**

8. *How do I use the burn test?* You can distinguish nitrate from safety film through the use of the burn test (a consumptive test). Cut a small snippet of film from the border (not the image area) of a negative or motion picture film. **Use a fume hood if one is available or an acid/organic vapor cartridge breathing apparatus that has been fitted to the user.** If you have no fume hood or apparatus, go outside of the building, far from any venting nitrate fumes, gasoline, or other flammable materials. Hold the film carefully by the corner using a hemostat or pair of long-handled tweezers.

Light the film snippet using a match.

- **Nitrate film** will burn brightly and consistently with an intense white-to-yellow flame. Fire should consume the nitrate snippet completely. Some nitrate film will have a camphor-like odor as it burns, although formulations varied during creation.
- **Safety film** will smolder and go out when the match is removed, leaving a melting or dripping mess behind and an acetic acid, vinegar-like odor.

You will need experience before you can use this test as a conclusive measure. On your first few attempts, work with film that has already been identified in order to experience the testing characteristics of both film types.

9. *How do I use the float test?* Another way to distinguish nitrate from safety film is the float or trichloroethylene test (a consumptive test). Trichloroethylene is a dangerous volatile chemical and a known carcinogen, so avoid touching the trichloroethylene or breathing in the chemical's vapors. **When working with trichloroethylene use a fume hood and wear neoprene gloves** or work outdoors using an acid/organic vapor rated cartridge in a rated breathing apparatus fitted to the user and neoprene gloves. Never carry this open chemical through your storage, work, or reference areas.

Take a 6 mm x 6 mm chip (snip) of film to be identified from a film border. **Be sure to cut only the non-image area.** Place the film chip in a beaker or test tube of trichloroethylene. Place a lid on the beaker and shake it or press the film chip down into the fluid until it is thoroughly wet. The film will either float, sink to the middle of the beaker, or sink to the bottom of the beaker.

- Cellulose ester (cellulose acetate, diacetate, and triacetate) safety films float at the top of the beaker.
- Polyester film floats at the middle of the beaker.
- Nitrate film sinks to the bottom of the beaker.

After the test you must work with your hazardous waste coordinator to store and/or dispose of the trichloroethylene and the test strips according to EPA guidelines.

10. *How do I use the diphenylamine test?*

Perform the diphenylamine test (a consumptive test) very carefully as the solution contains about 90% sulfuric acid. Obtain a solution of diphenylamine and sulfuric acid, as described in the Canadian Conservation Institute's "The diphenylamine spot test for cellulose nitrate in museum objects," *CCI Notes* (17/2). Place a small film chip (from a border or non-image area) on a microscope slide and add a drop of the prepared diphenylamine solution. After 60 seconds, if the film is nitrate, it will turn a deep blue. Both cellulose ester and polyester films will either remain clear or turn a very pale blue, not a vibrant, deep blue.

To confirm the test result, apply two additional drops of the solution to the film chip and wait another minute for the film to turn deep blue. Conduct this test under a fume hood or outdoors wearing an acid/organic-vapor rated cartridge in a rated breathing apparatus fitted to the user, as **the sulfuric acid may irritate your mucous membranes.**

11. *What determines the speed of nitrate deterioration?*

Nitrate begins self-destruction at the moment of creation. **Nitrate film self-destructs at an unpredictable rate.** The only way to estimate when nitrate will be unusable is to have a conservator conduct the consumptive tests listed in Section B.14 on each individual sheet or roll of film—hardly a practical alternative. Several factors cause chemical or mechanical deterioration of nitrate, including:

- **Manufacturing and processing history:** During the early days of mass photographic processing each batch of photographic film had a slightly different composition. Factors affecting the life of the image include:
 - the nitrate composition
 - the nitrate thickness
 - the emulsion quality

Residual processing chemicals, such as sodium thiosulfate and silver complexes, affect the life of the image but seem to have little to do with the actual life of the nitrate base. You may test for residual processing chemicals (particularly thiosulphate) in a variety of ways, ranging from using test strips to hiring a lab to conduct chemical tests, such as the methylene blue test. See Sections B.15 and C.15.

- **Storage and housing environment:** The storage and housing environment involves a wide range of factors that may affect the rate of deterioration, including:
 - air contamination and pollution
 - housing envelopes, sleeves, folders, and boxes
 - insects
 - light
 - mold

- relative humidity
- rodents
- storage equipment
- temperature
- ventilation
- water

See Sections C.11 and C.12 for information on how to house and acclimatize nitrate and cellulose ester films.

- **Handling:** Abusive handling can cause scratches and abrasion, while direct hand contact can deposit oils, which ultimately lead to emulsion staining. Avoid using nitrate frequently for duplication purposes as this places great stress on a negative. Never project nitrate. Reformat frequently used materials to provide access, duplication, and archival preservation master copies. See *COG 19/10*, "Reformatting for Preservation and Access: Prioritizing Materials for Duplication," for further help in determining what nitrate to reformat first.

12. *Is nitrate deterioration predictable?*

No. Although nitrate does go through five sequential stages of deterioration, without sophisticated chemical testing by a professional, it is impossible to predict how long the negative will exist in each stage. Film that has lasted for 60 years at stage 1 (relatively good condition) may go through stages 2-3 in only a few months, depending upon how the nitrate is stored and handled. Cold storage and regular inspection of nitrate is essential if collections are to be preserved.

13. *What are the stages of nitrate deterioration?*

There are five stages of nitrate deterioration.

- **Stage 1:** Film base discolors to a light amber tone.
 - Image fades.
 - A faint acidic or nitric acid smell may be detectable.
 - Image may stain, totally or in part, or exhibit "mirroring," where it becomes dark and reflective.
 - A black, rainbow-like iridescence may be visible, not unlike an oil slick.

(**Note:** Even the best preserved nitrate is now at least in stage 1 deterioration.)

- **Stage 2:**
 - Emulsion may soften.

- Negative may become sticky, attaching itself to paper sleeves or other film.
- Film base may become brittle.
- Film base amber color may deepen.
- A slightly stronger acidic or nitric acid smell may be apparent.

Note: In many cases stage 2 is the last stage at which nitrate can be copied or reformatted.

- **Stage 3:**

- Emulsion may begin to separate from the base.
- Nitric gas bubbles appear between the film base and the emulsion (image-bearing layer).
- Film base is very brittle and deep amber in color.
- Significant “mirroring out” or mirror-like, reflective black staining is apparent, often with a rainbow-like appearance.
- Nitric acid smell is strong.

- **Stage 4:**

- Emulsion begins to flow.
- Sticky froth appears on the negatives.
- Film sticks to nearby housing or negatives.
- Image surface is easily damaged.
- Nitric acid smell intensifies.

(Note: Film in this deterioration stage should be disposed of as hazardous waste. See C.16 and C.17.)

- **Stage 5:** **(Note:** Film in this deterioration stage should be disposed of as hazardous waste. See C.16 and C.17.)

- Emulsion turns into an acrid brownish or tannish powder that is highly acidic.
- Film shatters or breaks easily, as the nitrate base is **very** brittle.
- Film can self-combust if stored near high temperatures or sparks.
Note: This is a rare condition in still negatives except for those of the largest sizes housed without sleeves.

14. *What chemical tests can be used to predict whether nitrate life has been exceeded?*

Two chemical tests can indicate whether nitrate should be immediately destroyed or not. These tests are:

- the Alizarin red heat test
- the Micro-crucible test

Don't attempt to do these tests yourself without a sophisticated chemical laboratory and excellent training. Send film to be tested to an outside chemical laboratory, which will provide you with the results and a recommended date for retesting.

15. *What tests can be used to predict the life of cellulose ester films?*

The Image Permanence Institute developed A-D test strips® for use in determining the level of cellulose ester film deterioration. Similar to pH test materials, the strips indicate the level of degradation in individual films. Use the strips to determine if storage conditions are adequate and to help you set reformatting priorities. The strips are available from the Image Permanence Institute (one package contains 250 detector strips about 1 1/2" x 3/8", a color-reference pencil, and instructions), Rochester Institute of Technology, 70 Lomb Memorial Drive, Rochester, NY 14623-5604; Tel: 716-475-5199; Fax: 716-475-7230.

Place an individual strip in the container of the film to be tested (within a motion picture can, bag, box, sleeve, or cabinet). **Note:** Wear neoprene gloves to do this if you are working with deteriorated film. You may wear latex or cotton gloves if the film is undeteriorated. After exposure, the test strip color is compared to the reference pencil, which is printed with four bands of color, numbered from 0 to 3. The four bands of color correspond to the four levels of acidity. The reading indicates the extent of deterioration. **Note:** A-D test strips® are not useful indicators for polyester film deterioration. Some organizations, including the National Archives, however, are using them for indicating deterioration in **both** cellulose ester films (acetate, diacetate, and triacetate) **and** nitrate.

16. *How do I ensure the long life of cellulose ester films?*

Long life of cellulose ester film depends upon cool temperature, controlled relative humidity, a well-ventilated storage space, and good housing, as well as appropriate handling. The film age and type (acetate, diacetate, or triacetate) doesn't determine the speed of deterioration, though the original manufacturing, processing, storage, and handling history does affect the film life. Lowering the temperature to 2°F (-18°C) can extend by 200 times the life expectancy (LE) of film stored at 80°F. At 70°F the LE is approximately 100 years from the date of manufacture. Lowering relative humidity to 20% from 50% or higher can triple or quadruple the film LE.

The *IPI Storage Guide for Acetate Film* created by the University of Rochester's Image Permanence Institute can be used to predict life of acetate film at specific temperatures and relative humidities. Separate all nitrate and cellulose ester films from each other, from other film types, and from all deteriorated films of any kind. House these films in cold storage within the cold storage system configuration described in Sections C.11 and C.12. Place cellulose ester films in a cool, dry, well-ventilated space (ideally 0°F, 30% RH) housed separately from all other materials and office spaces to slow deterioration byproduct build-up. Use copies for reference and access.

Access the originals only when a new set of interpositives and copy negatives must be produced. If cold storage is not possible, house the materials off-site in cold storage. See Sections C.3, C.11, and C.12 for further guidance.

17. *Where can I get help on these issues of nitrate and cellulose ester identification and deterioration analysis?*

You can get help from SO and regional staff, Harpers Ferry Center (HFC) Division of Conservation staff, and from colleagues at your state university and state and local archives and libraries, as well as from contract archivists and curators.

C. Management of Nitrate and Cellulose Ester Films

1. *Do I have to keep nitrate film?*

Yes. You must keep nitrate film at stages 1 and 2 of deterioration (Section B.13) that has high artifactual, evidential, and/or associational value. Keep any nitrate film, regardless of value, if it has not yet deteriorated to stage 3 or beyond and has not been reproduced, inspected, and the reproduction approved. If you are uncertain about the value of film, keep it until an archivist can determine whether it has high artifactual, associational, or evidential value.

You may dispose of:

- *film with little or no artifactual, associational, or evidential value* as long as it has been reformatted and the copies have passed inspection
- *film of informational or administrative value* after high quality copies have been made that clearly reproduce **all** the information in the original and have passed inspection (If you are uncertain if all the information is conveyed in the copy, keep the original until an expert can check the film and copies to determine if the copies pass inspection.)
- *all film in stages 3-5 of deterioration* after you deaccession it, regardless of its original value

Work with your hazardous materials coordinator to dispose of badly deteriorated nitrate as hazardous materials according to the Environmental Protection Agency (EPA) Waste Codes and guidance. Don't attempt to do this by yourself. If your park has no hazardous materials coordinator, talk to your SO or regional curator or work with your local fire department to arrange a multi-park or regional disposition effort.

The only nitrate you must keep permanently after producing high quality copies that have been inspected is nitrate in deterioration stages 1 and 2 that has high artifactual or associational value and material of continuing evidential value. If you are inexperienced in judging value, keep all stage 1 and 2 nitrate film and make immediate arrangements for an experienced archival appraiser to determine whether to keep the originals.

See COG 14/8, "Caring for Cellulose Nitrate Film"; 19/10, "Reformatting for Preservation and Access: Prioritizing Materials for Duplication"; 19/12, "Contracting for Reformatting of Photographs"; and 19/13, "Preservation Reformatting: Inspection of Copy Photographs"; and Sections A.6, B.6,

B.11, B.13, and B.14 for further guidance. Also see *Museum Handbook, Part II (MH-II)*, Chapter 6: Deaccessioning, for guidance.

2. *Do I have to keep other deteriorating film types, such as cellulose acetate, diacetate, and triacetate?*

No. Deal with other deteriorating film types as you would nitrate, although cellulose ester films don't pose such major safety hazards, as they are **not** a fire risk. Some individuals are sensitive to the acetic acid given off by the cellulose ester films. If health or safety issues become a factor, such as those caused by badly deteriorated collections, mold, insect or vermin infestation, or a chemical spill, follow the nitrate guidance.

Keep all original materials of high artifactual, associational, and evidential value in cold storage. Reformat and inspect your deteriorating items **before** they can no longer be used. After deaccessioning contaminated items, work with a NPS hazardous waste coordinator to dispose of them according to EPA guidelines. See Sections A.6, C.14, C.16, and C.17.

3. *What special storage requirements must my facility meet?*

Don't store nitrate, acetate, diacetate, or triacetate in:

- office spaces
- attics
- general museum storage spaces
- historic buildings
- near windows or doors
- near light or heat sources
- in spaces with poor ventilation
- in spaces with no air conditioning
- in spaces without deluge sprinkler systems

For short-term storage of five years or less, house the collections as described in Section C.12, then place them in frost-free food freezers. This is **not** a recommended long-term solution because the deterioration byproducts may eventually build up in the freezer or refrigerator, causing health and safety hazards.

For long-term storage of more than five years, apply the National Fire Protection Association (NFPA) standards, particularly *NFPA 40, Storage and Handling of Cellulose Nitrate Motion Picture Film*, to all cellulose ester and nitrate film formats. No separate NFPA standards currently exist for still photographic negatives. Parks should not plan to store nitrate film for the long term on park grounds.

NFPA 40 is a rigorous standard that will result in very high-quality cold storage vaults with excellent venting, environmental controls, and fire resistance. However, the cost of applying this standard exceeds \$30 a square foot. NFPA 40 standards for vaults include stringent requirements for ventilation, refrigeration, heating, air conditioning, fire resistance, fire suppression, and temperature readouts. The vault will also require constant monitoring, much electricity, and scrupulous management to ensure

environmental stability. **Parks wishing to build a nitrate storage vault should not do so in or near historic structures or in the same building as visitor centers, staff offices, or collections.**

Label all nitrate storage areas and freezer vaults with the National Fire Protection Association (NFPA) Hazard Warning Symbol for nitrate shown in Figure M.1 below. Make sure that you notify all local fire stations of the presence and location of nitrate accumulations in your park. **Note:** If you are planning to store only cellulose ester films (which like nitrate should be housed in separate packaging and placed in containers separate from that of nitrate or polyester films), you simply need temperature, humidity, ventilation, and lighting control. See Sections C.11 and C.12 and COG 14/4, "Caring for Photographs: General Guidelines."

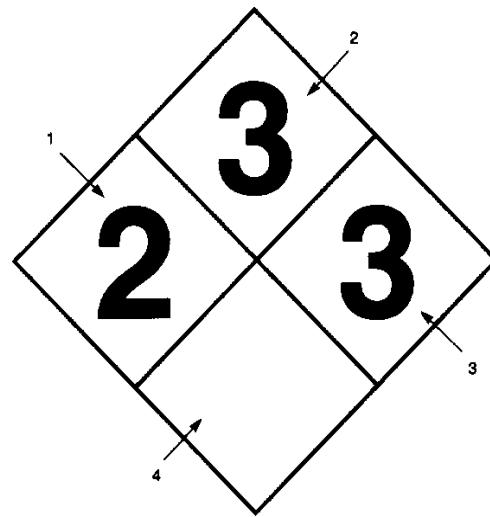

- 1 – Health Hazard (BLUE)
- 2 – Flammability Hazard (RED)
- 3 – Reactivity Hazard (YELLOW)
- 4 – Special Hazard (WHITE)

Figure M.1. National Fire Protection Agency Hazard Warning Sign for Cellulose Nitrate Film

4. *What other options do I have if I don't want to store film in my park?*

Consider the following options:

- **Rent a cold storage vault:** Hire a cold storage vault outside of the park, such as the Bowers or Iron Mountain facilities in Pennsylvania or Bonded Film Storage in Fort Leigh, New Jersey (201-944-3700) and W.R.S. in Pittsburgh, Pennsylvania (412-937-7700). Although these facilities don't meet the optimum requirements, they do offer improvement over standard office and museum storage.

Note: Henry Wilhelm states in *The Permanence and Care of Color Photographs*, on page 342, "At the time this book went to press in late 1992 . . . there was no commercially available humidity-controlled, low-temperature (0°F [-18°C] and 25% to 35% RH) film storage rental space available anywhere in the world." For more current information on cold storage suppliers, equipment, enclosures, and facilities that rent cold storage space, see the list in *Tools of the Trade*.

- **Use a NPS facility:** Move your film to a NPS storage and collections management facility with monitored cold storage, such as the Western Archeological and Conservation Center in Tucson or the San Francisco Maritime Museum.
- **Cooperatively share a vault:** Share a cold storage vault with a state, federal, or local agency, such as your state archives or library or a local university.
- **Sublet cold storage space:** Sublet cold storage space in a vault owned by another organization.
- **Ask for help:** Request cold storage space from the National Archives and Records Administration (NARA) or your Regional Archives Center, also operated by NARA.

5. *How should I manage nitrate that I must keep in the park on a short- or long-term basis?*

When managing nitrate, do the following:

- **Know the law,** particularly EPA, state, and local ordinances about the keeping and destruction of nitrate. Read the various standards and recommendations in the bibliography.
- **Talk to your local fire department and safety-related park staff.** Ensure that they know where the nitrate is located in the park and the quantities and condition of the nitrate. Label the nitrate storage areas clearly with the NFPA Hazard Warning Symbol for nitrate to facilitate effective fire fighting. See Figure M.1.
- **Isolate and label the materials** in a safe, humidity-controlled venting cold storage facility (0°F [-18°C] and 30% RH) far from museum storage, work, exhibit, and office areas.
 - Your best option is to use separate storage packets (nitrate separated from cellulose ester) with the nitrate packets housed in a separate environmentally stable vented cold storage chamber (vault room) by itself that meets NFPA standards.
 - Your second best option is to use separate storage packets (nitrate separated from cellulose ester) in environmentally stable cold storage with the nitrate and cellulose ester in the same cold storage vault. This option is perfectly acceptable as long as the temperature and humidity are both controlled (0°F (-18°C) or cooler and 30% RH), there is some venting, and a back-up power source is available.
 - Your third option is to use separate storage packets (nitrate separated from cellulose ester) protected by Molecular Sieves (dispersed molecular traps that absorb gaseous residues) with the temperature and humidity at least somewhat controlled in food freezer-type cold storage as described in Sections C.11 and C.12. Deteriorating materials should be duplicated and removed ASAP. This option is acceptable as long as the temperature and humidity are controlled and there is a back-up power source.

- Your fourth and least desirable option is to use separate storage packets (nitrate separated from cellulose ester) protected by Molecular Sieve materials in standard museum storage. Use this only for short periods as film materials are prepared for duplication prior to cold storage.

Standard food freezers or refrigerators, whether frost-free or not, do NOT meet fire code standards because they are not vented, don't stop the build-up of toxic gases, and don't meet the need for a powerful deluge-type, wet-pipe fire extinguishing system. Such storage is NOT acceptable for permanent nitrate storage.

- ***Duplicate materials*** following American National Standards Institute standards and archival best practices. (See *COG* 19/11, “Preservation Reformatting: Selecting a Copy Technology,” and 19/12, “Contracting for Reformatting of Photographs.”) **Note:** Digital copies are **not** preservation copies. See Section C.14.
- ***Inspect duplicates*** of the original materials carefully for accuracy, completeness, and technical quality. (See *COG* 19/13, “Preservation Reformatting: Inspection of Copy Photographs.”) Make new copies if any don't meet standards and reinspect. Repeat if necessary until high quality copies are achieved. See Section C.15.
- ***Evaluate the remaining nitrate's condition.*** If it is stage 3 or worse, work with a NPS hazardous waste coordinator to dispose of it according to EPA guidelines. See Section B.13 for a review of the stages. Keep materials with high artifactual, associational, and evidential value. (See Section A.6 and *COG* 19/10, “Reformatting for Preservation and Access: Prioritizing Materials for Duplication,” for guidance.)
- ***Deaccession and dispose of film*** deteriorated to stage 3 or beyond, film with no relevance to the park's SOCS, and well-copied items with only informational/administrative value. Transfer them to another institution after deaccessioning if they have value or dispose of them. See Sections C.16 and C.17 and *MH-I*, Chapter 6: Deaccessioning, for guidance.
- ***House materials with high artifactual, evidential, and associational values*** in appropriate housing and storage containers in cold storage. See *COG* 14/6, “Caring for Photographs: Special Monochrome Processes,” and Sections C.11 and C.12 below.
- ***Manage the cold storage facility*** carefully. Ensure that you have a back-up power source and a power outage alerting system in case of power failure. Inspect the contents every six months (see below). Check the cold storage facility weekly to ensure that there is no power outage or mechanical fault. Never store food or other materials in a film cold storage vault. Maintain monitoring records of the cold storage environment (temperature and RH).
- ***Inspect a different 10% of all retained nitrate, acetate, diacetate, and triacetate every six months*** for deterioration. Check RH indicator strips of materials in cold storage to identify punctured or torn bags requiring

replacement and re-drying of their special humidity-controlling enclosures. See Sections C.11 and C.12 for details on how to house materials for cold storage. Replace all punctured bags and re-dry the special boards being used as humidity buffers. Check the contents of punctured bags or bags whose humidity indicators detect humidity greater than 40% RH. Look for blemishes, silvering out, and other deterioration patterns described in Sections B.4 and B.13.

Remove negatives carefully from sleeves and look at them on a light table. To inspect motion picture film, unwind it slowly onto another reel with a smooth even pressure. If you find some seriously deteriorated items, arrange for their **immediate reformatting**, inspection, and disposal. **Note:** If more than 70% of the nitrate viewed during inspection is deteriorated, you should then inspect all of the remaining nitrate.

- ***Move the nitrate, acetate, diacetate, and triacetate to a remote cold storage facility if the power in your cold storage facility should go off for more than 48 hours.*** A nearby backup cold storage facility should be listed in your park's disaster and emergency operations plans. See *COG* 14/8, "Caring for Cellulose Nitrate Film."

6. *Should I isolate and handle cellulose acetate, diacetate, and triacetate in the same way?*

Yes. First reformat all acetate, diacetate, and triacetate film of value and inspect the copies. Place the undeteriorated originals that have high artifactual, evidential, and associational value in cold storage to slow deterioration and minimize the deterioration byproduct gases. Don't place these cellulose ester materials in the same cold storage chamber as nitrate unless the chamber is kept well ventilated and very, very cold (0°F [-18°C] or cooler and 30% RH).

House the film as described in C.11 and C.12. Don't place cellulose ester films in work spaces, museum storage, reference spaces, or office areas because they also give off acidic deterioration gas byproducts that may pose health hazards for some individuals. For more guidance, see the *IPI Storage Guide for Acetate Film* in the bibliography.

7. *What should I do when working with nitrate to avoid health hazards?*

First, isolate nitrate far from other collections, research rooms, and staff work and office spaces. When handling nitrate there are a number of routine precautions you should take:

- ***Maintain a log*** of who works with nitrate for health monitoring.
- ***Stop working with nitrate immediately*** if you experience any shortness of breath or eye or skin irritations.
- ***Wear protective clothing***, including:
 - latex or cotton gloves for undeteriorated film; neoprene gloves for deteriorated film
 - a long-sleeved, washable smock
 - goggles, if working with deteriorated film

- an acid/organic vapor-rated cartridge in a rated breathing apparatus fitted to the user
- **Wash regularly** all clothing, gloves, goggles, and work surfaces used for nitrate work; don't wear dirty or reused gloves
- **Don't wear contact lenses** when working with nitrate. Gases may build up under your lenses causing eye injury.
- **Limit your work with nitrate** to three hours per day.
- **Position a fan** so that the airflow blows fumes towards an air outtake valve or open window and away from you.
- **Never rub your skin, hair, or eyes** with a nitrate contaminated gloved hand.
- **Never inhale fumes** from nitrate or cellulose ester film.
- **Work in a cool space** far from any sources of heat, flames, or sparks.

8. *How do I avoid health hazards with cellulose ester films?*

Handle cellulose ester film as you would nitrate. Work only in a well-ventilated room to avoid breathing problems caused by acidic byproducts related to vinegar syndrome. (See Section B.3.) If the room lacks good ventilation, place a fan so it blows on you and position yourself in front of an air outtake register or open window, so the fumes are sucked away from you. Wear neoprene gloves if the film is deteriorated, or cotton or latex gloves if the film is in good condition. If the film is deteriorated and the ventilation is poor or you are sensitive to cellulose ester film, wear an acid/organic vapor-rated cartridge in a rated breathing apparatus fitted to the user. Don't wear contact lenses around cellulose ester film.

9. *How should I mark nitrate and cellulose ester films?*

Individual copy negatives and interpositives may be marked on their reverse edge (on the back in an area that is the reverse of the border of the image) with a photographic marking pen that has neutral pH carbon ink and has passed the Photographic Activity Test (PAT). The PAT is described in *COG 14/2*, "Storage Enclosures for Photographic Prints and Negatives." Consider using the Pigma Ink pen by Light Impressions for marking.

Remove all images before writing on an envelope or sleeve. Let image labeling dry thoroughly before re-inserting images in sleeves or envelopes. Generally mark only minimal information (the negative number or catalog number) in very small characters on the non-emulsion side in the non-image area. Never mark in the actual image area or on the reverse of the image. Label envelopes and sleeves on the seamed side, or if using a four-fold sleeve, label on the top of the fold area.

10. *What common factors affect the life expectancy of nitrate and cellulose ester films?*

Of all the factors affecting nitrate life, temperature, relative humidity, ventilation, handling, and housing systems and equipment are perhaps the most significant. Recent studies by Peter Adelstein and others indicate that the nitrate storage environment, particularly temperature and humidity, are crucial to safe handling and long nitrate life. For every 10°F decrease in storage temperature, the film life is almost doubled. Lowering relative

11. *What materials and systems should I use to house my nitrate and cellulose ester?*

humidity to the 40-60% range from the 70-80% range doubles the life of the film. For long-term storage, 20-30% RH is recommended.

Use housing that meets the *American National Standards Institute (ANSI) Standard IT 9.2-1991, Photographic Processed Films, Plates, and Papers-Filing Enclosures and Storage Containers*, that is a high alpha-cellulose clamshell box made of acid-free materials with reinforced seams. Select high-alpha cellulose, four-fold paper sleeves that pass the photographic activity test. Transfer the label and caption information onto this folded side, and place the emulsion so it faces the non-fold side. Place the emulsion side of negatives away from the labeled side of the sleeve to avoid label loss if the film deteriorates. If you use a slide-in sleeve, treat the seamed side like a flap so that the emulsion is away from the seam on the unlabeled side. Use buffered sleeves for cellulose nitrate and for black-and-white cellulose ester film, but use unbuffered sleeves for all color film.

For long-term storage, place your rehoused collections in polyethylene bags or polypropylene film cans within drop-front storage boxes within a second layer of polyethylene bag inside a cold storage vault. Use zeolite materials (dispersed molecular traps that absorb gaseous residues) to protect your film from the buildup of acidic gas byproducts that hasten film destruction if the items are:

- particularly precious
- very large format (8" x 10" and larger) or in large quantity (more than 35 pounds)
- unable to be placed immediately in a cold storage vault
- in a vault with poor environmental controls

Zeolite materials include MicroChamber™ packaging or FPC® Molecular Sieve packets. The packets are placed inside each film container. The packaging is used just as acid-free packaging is normally used. Zeolite materials without cold storage don't by themselves provide adequate protection from deterioration. They simply capture gaseous byproducts that speed deterioration; they don't stop deterioration. Don't reuse zeolite or other housing materials or old containers of any sort. If a film can or box is deteriorated, replace it. Zeolite is an excellent storage material, but may be too expensive for many uses.

The use of the double-bag or Safecare®-type housing system (which includes polyethylene bags, humidity conditioned mat board, RH indicator strips, and boxes) for cold storage of film protects it from condensation, mechanical damage, and handling damage. **Note:** All of the materials found in the Safecare® system are currently found in the *Tools of the Trade*.

If you use venting, hazardous-material freezer(s) for long-term housing without zeolite housing or FPC® Molecular Sieve packets, keep nitrate and cellulose ester films in separate packages within the freezer(s) as described here and in C.12. When possible, also house and store deteriorated film separately from non-deteriorated film. Keep film freezers far from office, museum storage, work, or reference spaces (at least not in the same building and not in any historic structure). Ideally, all vaults and freezers should be checked for collection deterioration at least every six months.

The combination of the two systems—zeolites to control outgassing and Safecare®-type storage systems to control condensation, mechanical damage, and handling damage during cold storage—is ideal. This combination provides maximum protection although the cost may be excessive. Cold storage and the Safecare® system of polyethylene bags, board, and humidity indicator alone are an excellent and relatively inexpensive storage option. A third system is the use of heat or pressure seal bags constructed of layers of foil, paper, and plastic. These bags form an excellent moisture barrier but can't be easily reused after opening, nor are they transparent for examining the condition of the film. These sealed, multi-layered bags are also significantly more expensive than the polyethylene bags.

For long-term storage, house each type of material (deteriorated nitrate, undeteriorated nitrate, deteriorated cellulose ester films and undeteriorated cellulose ester films) separately in its own cold-storage package. Never mix deteriorated and undeteriorated materials or cellulose ester and nitrate materials in the same package. When housed in a cold, dry environment (0°F [-18°C], 30% RH), in dark storage, with low-levels of gaseous pollutants, and a good air circulation/ventilation system, nitrate negatives will endure.

Container selection is also important. Using acidic housing, tightly sealed housing, or no housing hastens nitrate destruction by allowing gas buildup in containers or storage spaces. Except when housed in cold storage or with zeolite materials, place nitrate in vented storage in order to allow the nitric oxide gases to escape. Even cold storage rooms should be explosion proof and vented without internal electrical components other than lighting and humidity/temperature gauges. See Section C.3 for information on short- and long-term storage.

12. *How should I prepare my collections for cold storage?*

Don't rehouse materials for cold storage until **immediately** before storing them. Long-term storage at room temperature in sealed containers or plastic envelopes or sleeves may be damaging. If a film can or box is deteriorated, replace the container. Don't reuse old containers. Ideally, select vented polypropylene cans for film. To implement this system place sleeved film (either buffered or zeolite materials) within cold storage kits configured like the Safecare® system, which works as follows:

- **Step 1:** Condition the film by storing it at 40% RH for several days to limit the possibility that condensation will form within the sealed bags when the bags are placed in the cold storage.
- **Step 2:** Rehouse the images in acid-free sleeves or envelopes or in vented polypropylene film cans. **Note:** If you have adequate funds, use zeolite sleeves for negatives and place FPC® Molecular Sieve packets in the boxes housing the film or film cans when you have either rapid deterioration or less than optimum environment controls or you have materials of exceptional artifactual value.
- **Step 3:** Place the sleeved or canned film within a polyethylene bag with a RH indicator strip, then gently press all the air out of the bag before sealing.
- **Step 4:** Oven-dry (200°F for 3-5 minutes) or microwave-dry (full power for 30 seconds, then turn and repeat) a pre-cut mat board; then allow it to cool.

- **Step 5:** Label a 13" x 10" x 1½" drop-front storage box with the collection name, catalog number, "hazardous nitrate," and any other useful information.
- **Step 6:** Place the cool oven-dried mat board in the bottom of the storage box. Don't overfill the box.
- **Step 7:** Check the bag seal to ensure it is tight and complete.
- **Step 8:** Place the bagged film on top of the mat board. Don't place more than one type of film (nitrate, deteriorated cellulose ester, undeteriorated cellulose ester) in a single box.
- **Step 9:** Place a second oven-dried mat board on top of the bag holding the film. Close the box lid.
- **Step 10:** Place the box inside the second polyethylene bag, add the second RH indicator strip, then press all the extra air out and seal it. Check the RH indicator strips every six months or so.

Sealed materials housed in cold storage in this way should be stable for up to 15 years before you must re-dry the mat board and replace the RH indicator strips. When you remove materials from cold storage, allow them three hours to acclimatize before unsealing. Acclimatize the materials by placing them on an open rack for even heat transfer **before opening the bag**. Wipe off any condensation from the outer bag before opening it.

If you rehouse the image in cold storage, oven dry the mat boards again before replacement. Check all polyethylene bags for holes prior to reuse. Replace all bags with poor seals or holes. Don't place packaged materials directly on the floor of the cold storage facility or on closed shelves directly under pipes. Label the freezer with the NFPA Hazard Warning Symbol for nitrate. See Figure M.1. If you use FPC® Molecular Sieve packets, house the film as described above, but use double polyethylene bags to contain the film storage can or negatives

13. *How should I clean dirty films?*

Never try to clean film in stages 3-5 of nitrate deterioration or any film with a sticky, soft, flowing, flaking, or powdering emulsion. If you must clean cellulose ester or nitrate film, don't use water or solvents, but you may use compressed air or brush the film gently with a soft, clean, and wide camels hair brush. If any damage is noted, stop immediately. Wash the brush regularly and allow it to dry thoroughly before resuming work. Ideally, use several brushes, so you won't have to wait for them to dry before resuming cleaning. Generally, clean only for duplication purposes.

14. *How should I reformat my nitrate and cellulose acetate, diacetate, and triacetate?*

Work with a photographic contractor who is a specialist and understands the fire and safety hazards involved in nitrate duplication and has experience copying deteriorating nitrate or cellulose ester film. Ask your state librarian or archivist for local recommendations.

- Work with a NPS or other expert or your regional/SO curator to select a reformatting technology, prepare your contract, and implement a quality control program.

- Select a contractor who has scanning laser or cathode ray tube cameras, which don't have hot, quartz-iodine light bulbs.
 - Select items to be reformatted based on the park's Scope of Collection Statement and the film's value, use, and risk. See Section A.6.
 - Select a reformatting process.
 - Write the contract. Insist on the use of long-lived film with a polyester film base, small grain, long tonal range, and good resolving power. Cite the processing standards in the contract.
 - Clean the film, if necessary, using a brush and compressed air. See Section C.13 above.
 - Pack the film for shipment.
 - Inspect the returned copies side-by-side against the original on a light table with color balanced bulbs. Visually inspect the film for completeness. See *COG* 19/13, "Preservation Reformatting: Inspection of Copy Photographs."
 - Have a professional test the film density, resolution, and residual thiosulfate of the copy (densitometric tests and methylene blue tests).
 - Reduplicate any images not meeting inspection and testing standards.
 - Reorganize the copy film to match the original order of the original film. See *MH-II*, Appendix D: Museum Archives and Manuscript Collections, Section J.
 - Label and rehouse the reformatted copies. See Section C.12 above.
 - Store copies as described in *MH-I*, Appendix R: Curatorial Care of Photographic Collections.
 - Analyze the original film's deterioration state. See Sections B.13 and B.15.
 - Rehouse any originals to be kept in appropriate materials, polypropylene bags, and cold storage after acclimatization at 40% RH. See Sections C.11 and C.12.
 - After deaccessioning, work with the park's hazardous materials coordinator to destroy selected deteriorated originals according to EPA standards. See Section C.1 for guidance on what to destroy and Sections C.15, C.16, and C.17 on how to dispose of it.
 - Set up standard operating procedures to limit access to negatives collections except when making new negatives, answering FOIA requests, or meeting other legal requirements, such as subpoenas.

- Be particularly careful to warn all personnel involved in handling, shipping, or caring for nitrate about the need to keep it cool and away from sparks and ignition sources.
- Don't expect to use digital copies effectively as preservation copies unless your park has developed a professional electronic records migration strategy. Such a policy involves systematic retensioning (rewinding and production of a new tape pack) annually or biannually, data refreshing every three to four years, and migration (copying to new format or media) each time the hardware or software changes (at least every five years). When setting up such a migration strategy, you should plan to keep your large digital master file off-line in non-proprietary and uncompressed formats. You will use derivative usage files online rather than your master files.
- Follow the specific guidance in *COG* 14/8, "Caring for Cellulose Nitrate Film"; 14/4, "Caring for Photographs: General Guidelines"; 19/10, "Reformatting for Preservation and Access: Prioritizing Materials for Duplication"; 19/11, "Preservation Reformatting: Selecting a Copy Technology"; 19/12, "Contracting for Reformatting of Photographs"; and 19/13, "Preservation Reformatting: Inspection of Copy Photographs."

15. *How should I inspect reformatted nitrate that has been returned?*

Follow the techniques for visual inspection, and densitometric, resolution, and residual chemistry testing described in *COG* 19/13, "Preservation Reformatting: Inspection of Copy Photographs." Once the copies have been approved, check the original nitrate's deterioration state. If it is at stage 3 or beyond (see Section B.13), deaccession the nitrate and work with the park or region's hazardous materials coordinator to dispose of the film as hazardous waste according to the EPA guidelines. If the film is at stage 1 or 2 of deterioration, and it has high artifactual, evidential, or associational value (see *COG* 19/10, "Prioritizing Material for Reformatting"), then place the collections in appropriate housing and put them in suitable cold storage after acclimatizing them. See Sections C.11 and C.12. Otherwise, deaccession and dispose of the material.

16. *Do I have to deaccession reformatted nitrate negatives?*

<p><i>If the nitrate negatives are in...</i> Stage 1 or Stage 2 of deterioration,</p>	<p><i>Then...</i> reformat them and inspect the copies. Once you have approved the copies you can dispose of the originals. Don't deaccession the negatives, as you are preserving the images as stable, high quality surrogates.</p>
<p><i>If the nitrate negatives are in...</i> Stage 3, Stage 4, or Stage 5 of deterioration and you will be unable to reformat them,</p>	<p><i>Then...</i> deaccession them and dispose of them as an immediate threat through your hazardous materials coordinator. Negatives that have deteriorated to this level have lost their informational value.</p>

Refer to *MH-II*, Chapter 6, Deaccessioning, for information on deaccessioning nitrate negatives.

17. *Can I destroy reformatted nitrate negatives?*

You can destroy nitrate negatives that have been reformatted if:

- they have only informational or administrative value
- you have a high quality copy that has been inspected to current standards

Don't destroy nitrates that have high artifactual, evidential, or associational value. See Section A of this appendix for definitions of these types of value.

Destroying nitrate negatives that have only informational or administrative value and that have been copied to current standards isn't a deaccession. This is because you still have the image.

18. *How do I document reformatted nitrate negatives?*

Document the reformatting of nitrate negatives in ANCS+. For collections in the Collections Management Module, use the Notes field in the Images supplemental record. Enter the replacement negative(s) in this supplemental record.

For collections in the Archives Module, use the Original Duplicates supplemental record. You can use this record at any level in the module. Enter the replacement negative(s) in this supplemental record. Use the location field in this supplemental record to enter the nitrate location.

Use the following, or similar, wording to document the reformatting of nitrate negatives.

If the original nitrate has been destroyed, note:

Original nitrate(s) replaced on (date) by (name) with (film type, for example, polysulfide toned black-and-white gelatin silver continuous tone film on polyester base) and checked for quality by (name) on (date). Original nitrate destroyed on (date) by (name/title of hazardous materials coordinator).

If you are keeping the original nitrate, note:

Original nitrate(s) replaced on (date) by (name) with polysulfide toned black-and-white gelatin silver continuous tone film on polyester base that has been checked for quality. Original nitrate was separated and removed to (location that includes cold storage company, cooperator, or park; address; and phone number).

19. *How do I dispose of nitrate?*

Don't do this by yourself. Instead of throwing hazardous nitrate in the trash or burning it, work with your park or regional hazardous waste coordinator to arrange for the disposition of nitrate and deteriorated cellulose ester film according to EPA guidelines. If you have no hazardous materials coordinator, contact your regional/SO curator for help in locating a NPS hazardous materials coordinator who can assist you or work with your local fire department.

20. *When should I keep original nitrate?* Don't destroy nitrate if you:
- don't have hazardous waste training and facilities
 - don't know the EPA guidelines and your state and local laws on nitrate disposition
 - find that your nitrate has high artifactual, evidential, and/or associational value (See Section A.6 and *COG 19/10*, "Reformatting for Preservation and Access: Prioritizing Collections for Duplication.") **Note:** If deteriorated beyond stage 3, the nitrate no longer has informational and administrative value. See Section B.13 for an overview.
 - find that your nitrate has not yet been duplicated and inspected and the original is in stage 1 or 2 of deterioration (See B.13 for an overview.)
 - don't know the values or deterioration state of the original (See Section A.6 and *COG 19/10*, "Reformatting for Preservation and Access: Prioritizing Images for Duplication.")
21. *How do I train my staff to handle, house, store, and manage nitrate and cellulose ester film?* Work with your regional/SO curator to provide:
- training courses
 - details and cross-training under the guidance of trained visual archivists for hands-on experience
 - tours and visits to state archives and libraries
 - training manuals and Web access
22. *How should I answer requests for access to nitrate?* Nitrate poses a significant health hazard for researchers. ***For health and safety reasons, researchers should work with copy prints, not nitrate or deteriorated cellulose ester films.*** If you receive a Freedom of Information Act (FOIA) request for nitrate or deteriorated cellulose ester film, work with your FOIA officer, regional public relations officer, regional/SO curator, and park superintendent to determine how to proceed without risking the health and safety of staff and researchers.

D. Prevention of Nitrate Fires

1. *What causes nitrate fires?* At temperatures of 100°F (38°C) or above, quantities of deteriorated nitrate can self-combust, although undeteriorated nitrate doesn't burn until it reaches 266°F (130°C). Self-combustion is caused by the combination of high environmental temperature, low RH, lack of ventilation, flammable material, and a heat producing (exothermic) reaction due to deterioration byproduct gas buildup leading to accelerating deterioration and ever-higher temperatures.

Other, more common causes of nitrate fires include:

- *sparks* from:
 - smoking
 - equipment
 - faulty wiring
- *excessive heat* from:
 - radiators and space heaters
 - skylights and windows
 - poorly vented attics

2. *How do I prevent a nitrate fire?*

There are several simple rules:

- ***Learn the standards:*** Before housing quantities of nitrate in any structure, obtain the latest National Fire Protection Association NFPA 909, Standard for the Protection of Cultural Resources Including Museums, Libraries, Places of Worship, and Historic Properties. Read it thoroughly and apply it with care. Contact the association at 1 Battery-march Park, PO Box 9101, Quincy, MA 02269-9101; Tel: 617-770-3000.
- ***Limit quantities*** near public spaces, in general museum storage, in offices, or near heavy equipment, and other fragile, valuable, or flammable materials: Never store quantities of nitrate (more than 20 standard rolls or 20,000 feet of roll film—either motion picture film or professional still photographic negatives on the roll—or 35 pounds or 875 individual still negatives [$>4" \times 5"$]).
- ***Rehouse nitrate:*** House the film as described in Section C.11 and place it in cold storage that meets fire specification standards until you have a chance to reformat and inspect the resulting copies. Never reuse housing that has previously held nitrate film.
- ***Label nitrate clearly:*** Indicate on all boxes, cans, and other containers, that the material inside is nitrate. Label all cabinets with the phrase, “Hazardous nitrate film is contained.” Label the room doors with the NFPA Hazard Warning Symbol for nitrate. See Figure M.1.
- ***Inspect regularly:*** Never warehouse nitrate. Inspect the film at least every six months. Monitor the cold storage vault weekly to ensure that it is still operating. If not, transfer the film to your back-up cold storage facility. See Sections C.5 and C.15.
- ***Dispose of deteriorated nitrate:*** Never keep badly deteriorated nitrate (materials in deterioration stages 3-5). Once found, determine if the material is too badly deteriorated to copy (some stage 3 items may be copied). If too badly deteriorated to copy, deaccession and dispose of the nitrate as hazardous material.

- **Don't project nitrate:** Never allow projection of nitrate film.
- **Don't allow ignition sources nearby:** Never allow any smoking or other sources of ignition or heat (for example: no space heaters or halogen lights) in or near any space where nitrate is housed. The only heating sources allowed in or anywhere near nitrate is steam or water pipe heat kept below 15 psig.

3. *At what temperatures are nitrate materials dangerous?*

According to Photographic Conservator Henry Wilhelm and Eastman Kodak, older deteriorated nitrate film is capable of self-combusting at temperatures as low as 100°F (38°C) when housed at that temperature for prolonged periods. Fires at that temperature, however, are not common. High temperature coupled with the heat generated by the decomposition of gases that can't escape and a low relative humidity can cause these 100°F fires.

Various factors might have halted the self-combustion of these deteriorated nitrate films, including:

- higher relative humidity
- venting of the deterioration gases
- lower ambient temperature

See Sections C.3, C.5, and C.11 for specifics.

Self-Combustion Danger Alert Table	
Temperature	Type of Material
100°F (38°C)	Older deteriorated nitrate (stage 3 and above) may spontaneously combust at this temperature.
104°F (40°C)	Motion picture film and large quantities of large-sized (>5" x 7") negatives may self-combust at this temperature.
266°F (130°C)	New undeteriorated nitrate may self-combust at this temperature.

Large quantities of nitrate, when housed together, will deteriorate at an ever accelerating rate due to the buildup of heat and acidic gases and may spontaneously ignite, producing toxic gases.

To prevent nitrate film deterioration, fires, and health hazards, don't store large quantities of nitrate in closed, non-venting packages unless you immediately place the packages in cold storage. Larger format negatives in any quantities should be individually rehoused in zeolite or in buffered paper with an open side next to Molecular Sieve packets. Keep all nitrate storage containers, open or venting, and away from other valuable materials. Ideally use cold storage and acid-free buffered or zeolite paper and Molecular Sieve packets configured as described in Section C.11.

4. *What materials pose the greatest risk of causing a nitrate fire?*

The materials at greatest risk of burning are:

- **roll film** (motion picture film or professional still negatives on a film roll that have not been cut up into individual images) in quantities of 20,000 linear feet or greater, 20 or more reels of motion picture film, or 35 pounds or more of large format negatives (that is roughly 875 negatives larger than 4" x 5"), aerial film, or X-ray film
- **bulk packed nitrate**, particularly professional film, in large quantities (more than 35 pounds or 875 negatives) regardless of format
- **trapped nitrate** that is tightly sealed in a non-venting drawer or container that doesn't allow the heat and fumes to safely dissipate
- **unsleeved negatives** or items not housed individually in buffered paper or board housing materials that can absorb the acidic fumes, such as papers with buffering, Molecular Sieves, activated carbon, and molecular traps to absorb harmful molecules (Again, professional film is particularly dangerous.)
- **any deteriorated nitrate** in large quantities (more than 35 pounds), particularly nitrate deteriorated beyond stage 2 (See Section B.13 for a review of stages of deterioration.)

5. *What nitrate materials pose the least risk of causing a nitrate fire?*

Small quantities of undeteriorated still nitrate sheet film housed in individual buffered sleeves within vented or open containers don't pose as significant a hazard. Despite their relative safety, however, they must be housed long-term (more than 5 years) in cold storage as described in Sections C.11 and C.12, preferably outside of the park.

6. *What should I do in case of a nitrate fire?*

First evacuate the building and the area as nitrate burns explosively producing extremely toxic gases. Call the fire department **immediately** from another building. If you still have time, supercool the fire by directly applying large quantities of the coldest water or snow in any reasonable way possible from fire hoses to heavy equipment. **Don't get so close to a nitrate fire that you breathe in the toxic fumes.**

Prevention is the only truly safe way to stop a nitrate fire. Nitrate fires are rarely put out without first destroying the buildings that house them. While the direct causes of fires are often undiscoverable after a nitrate explosion, they appear most frequently to be heat buildup caused by the accumulation of nitrate deterioration gases due to inadequate housing, venting, and cooling. **Nitrate poses a significant risk to historic structures, staff, and collections.**

- **Small Fire:** To extinguish a small nitrate fire, supercool the fire to below 320°F (160°C) through the application of snow, cold water, or carbon dioxide using any tools at hand, such as fire hoses, hoses, heavy equipment, and so forth. Stay at a safe distance from the fire so you won't be at risk of breathing toxic fumes. It may not be possible to put the fire out, as nitrate produces oxygen as it burns. Nitrate can burn under sand, water, halon, and other smothering-based fire extinguishing systems.

- **Larger Fire:** It may not be possible to put out a large nitrate fire, particularly if roll or motion picture film is burning in any quantity. Roll and motion picture film fires usually burn until they have totally consumed the film and the surrounding building

7. *What nitrate fires have occurred recently?*

In 1978, nitrate fires at both the International Museum of Photography and the National Archives cold storage facility in Suitland, Maryland, caused many millions of feet of historic motion picture film and still negatives to be destroyed, as well as the structures holding them. Among the works destroyed were the original motion picture negatives of such commercial works as *Strike Up the Band* with Judy Garland and Mickey Rooney.

8. *What do I do if my nitrate or cellulose ester becomes wet during fire fighting or cold storage?*

Wet nitrate film is at great risk for very rapid deterioration. Take the film within 24 hours to a local photographic salvage shop that works with nitrate or air dry or freeze it immediately. According to Deborah Hess Norris in *Disaster Recovery, Salvaging Photograph Collections*, image-bearing gelatin layers in deteriorated nitrate may dissolve in water, leaving only the nitrate base behind. In cellulose ester films, the water may be trapped in the channelized layers, leading to rapid deterioration. Some dyes in nitrate and cellulose ester films may run and bleed pink or blue onto other nearby materials.

Salvage nitrate and cellulose ester materials rapidly if exposed to water. Separate the materials from their housing and air-dry them immediately in a vertical position using clotheslines and wood or plastic clips, such as clothespins. Salvage and air-dry the housing as well in order to preserve the information it contains. Keep nitrate separate from all other materials in a separate room.

E. Bibliography

Adelstein, P. Z., J. M. Reilly, D. W. Nishimura, and C. J. Erbland. "Stability of Cellulose Ester Base Photographic Film: Part I—Laboratory Testing Procedures," *SMPTE Journal* 101, no. 5 (May 1992): 336-346.

_____. "Stability of Cellulose Ester Base Photographic Film: Part II—Practical Storage Conditions," *SMPTE Journal* 101, no. 5 (May 1992): 347-353.

American National Standards Institute, Inc. *ANSI IT9.1-1996 American National Standard for Imaging Media-Processed Safety Photographic Film—Storage*. New York: American National Standards Institute, Inc. 1993. (**Note:** Available from ANSI, 11 West 42nd Street, New York, NY 10036; Tel: 212-642-4900; Fax: 212-398-0023)

_____. *ANSI IT9.11-1991m American National Standard for Imaging Media-Processed Silver-Gelatin Type Black-and-White Film-Specifications for Stability*. New York: American National Standards Institute, Inc., 1991.

"Big Fire at Lubin Plant." *The Moving Picture World* 27 (June 1914).

Bradley, John G. "Stability of Motion Picture Film." *Journal of the Society of Motion Picture Engineers* (December 1936).

Brecha, H. C. "How Humidity, Temperature Affect Motion-Picture Film." *Heating, Piping and Air Conditioning* 22 (September 1950): 106-198.

- Brems, Karel Al H. "The Archival Quality of Film Bases." *SMPTE Journal* 97, no.12 (December 1988): 991-993.
- Cummings, J. W., A. C. Hutton, and H. Silfin. "Ignition of Decomposing Cellulose Nitrate Film." *Journal of the Society of Motion Picture Engineers* 23 (November 1951): 82-83.
- Eastman Kodak. *The Book of Film Care*. H-23. Rochester, N.Y.: Eastman Kodak, 1983.
- Fisher, Monique, and Andrew Robb. "Guidelines for Care and Identification of Film-Base Photographic Materials." In *Topics in Photographic Preservation*, 117-122. American Institute for Conservation/Photographic Materials Group 5, 1993.
- Hendriks, Klaus. *Fundamentals of Photograph Conservation*. Ottawa, Canada: National Archives of Canada, 1991, pp. 210-281.
- _____. "The Duplication of Historical Black and White Negatives." *Journal of Imaging Technology* 12, no. 4 (1986).
- _____. *The Stability and Preservation of Recorded Images*. Ottawa, Canada: National Archives of Canada, 1989.
- Hess Norris, Deborah. *Disaster Recovery: Salvaging Photograph Collections*. Philadelphia: Conservation Center for Art and Historic Artifacts, 1978.
- "Historic Film Destroyed in Archives Fire." *The Washington Post*, Dec. 8, 1978.
- Horvath, David. "Survey of Acetate Negative Collections." In *Topics in Photographic Preservation*, 25-39. American Institute for Conservation/Photographic Materials Group 1-2, 1986 and 1988. (*Note*: This report may be purchased postpaid for \$8 from the University of Louisville, Photographic Archives, Ekstron Library, Louisville, KY 40290; Tel: 502-588-6752.)
- Keefe, Laurence E., and Dennis Inch. *The Life of a Photograph*. Boston: Focal Press, 1990.
- National Board of Underwriters. *Regulations for the Storage and Handling of Photographic and X-Ray Nitrocellulose Films*. National Board of Underwriters, 1925.
- National Bureau of Standards. "Fire Effects and Fire Control in Nitrocellulose Photographic-Film Storage." In *Building Materials & Structures*, Report 145, 1956.
- _____. "Fire Hazard of Nitrocellulose Motion Picture Film." *Technical News Bulletin* 40 (January 1956): 3-5.
- National Fire Protection Association. *National Fire Protection Guide for Explosion Venting, NFPA 68*. Quincy, Mass.: National Fire Protection Association, 1988. All NFPA standards are available from NFPA, 1 Batterymarch Park, PO Box 9101, Quincy, MA 02269-9101; Tel: 617-770-3000.
- _____. *National Fire Protection Life Safety Code*. Quincy, Mass.: National Fire Protection Association, 1988.
- _____. *National Fire Protection Standard for Fire Doors and Water Spray Fixed Systems for Fire Protection*. Quincy, Mass.: National Fire Protection Association, 1988.
- _____. *National Fire Protection Standard for the Installation of Air Conditioning and Ventilating Systems*. Quincy, Mass.: National Fire Protection Association, 1988.

- _____. *National Fire Protection Association Standard for the Protection of Cultural Resources Including Museums, Libraries, Places of Worship, and Historic Properties, NFPA 909*. Quincy, Mass.: National Fire Protection Association, 1997.
- _____. *National Fire Protection Association Standard for the Protection of Records, NFPA 232*. Quincy, Mass.: National Fire Protection Association, 1986.
- _____. *Standard for the Storage and Handling of Cellulose Nitrate Motion Picture Film. NFPA 40-1982*, National Fire Protection Association.
- Nishimura, Douglas. "The IPI Storage Guide for Acetate Film." In *Topics in Photographic Preservation*, 123-134. American Institute for Conservation/Photographic Materials Group 3, 1988. Available from the Image Permanence Institute (\$25) along with the A-D strips (package of 250 is \$45.) at Rochester Institute of Technology, 70 Lomb Drive, Rochester, NY 14623-5604; Tel: 7156-475-5199; Fax: 716-475-7230.
- Proceedings of a Board of the Chemical Warfare Service appointed for the purpose of investigating the disaster at the Cleveland Hospital Clinic, Cleveland, Ohio, on May 15, 1929*. Washington, D.C.: Government Printing Office, 1929.
- Puglia, Steve. "Negative Duplication: Evaluating the Reproduction and Preservation Needs of Collections." In *Topics in Photographic Preservation*, 123-134. American Institute for Conservation/Photographic Materials Group 3, 1988.
- _____. "The Preservation of Acetate Film Materials—The Cost-Benefit Analysis for Duplication and Cool/Cold Storage." In *Topics in Photographic Preservation*, 50-79. American Institute for Conservation/Photographic Materials Group 6, 1995.
- Reilly, James, Douglas Nishimura, Luis Pavao, and Peter Adelstein. "Photo Enclosures: Research and Specifications." In *Topics in Photographic Preservation*, 1-8. American Institute for Conservation/Photographic Materials Group 3, 1989.
- Schobert, Mary, Dorothy C. Munson, and Doug Munson. *Management of Cellulose Nitrate Negative Collections: Recommendations for the National Park Service Southeast Region*. Cooperative Agreement 1443CA589097014 between the National Park Service United States Department of the Interior and Conservation Center for Art and Historic Artifacts and Chicago Albumen Works. Boston and Washington, D.C.: National Park Service, 1998.
- Scribner, B. W. "Summary Report of Research at the National Bureau of Standards on the Stability and Preservation of Records on Photographic Film," *National Bureau of Standards Miscellaneous Publication MI62* (May 1939).
- "\$3 Million Loss in Eastman Fire." *Democrat and Chronicle* (May 30, 1978). Rochester, N.Y.
- Wilhelm, Henry. "Problems with Long-Term Stability of Kodak Professional Direct Duplicating Film." *Picturescope* (Spring 1982): 24-33.
- _____. and Carol Brower. *The Permanence and Care of Color Photographs: Traditional and Digital Color Prints, Color Negatives, Slides, and Motion Pictures*. Grinnell, Iowa: Preservation Publishing Company, 1993.

Appendix N: Curatorial Care of Wooden Objects

	<u>Page</u>
A. Overview	N:1
What is covered in this appendix?.....	N:1
What types of wooden objects are found in museum collections?.....	N:1
How much care do wooden objects require?	N:1
Should I provide on-site care myself or contact a conservator?	N:1
B. The Nature of Wood	N:2
What is the structure of a tree?	N:2
What are the three planes common to trees and lumber?	N:2
What effect does water have on wood?	N:3
Do all types of wood react in the same way?	N:4
Where is this difference in dimensional change evident in museum objects?	N:4
C. Agents of Deterioration	N:4
What's involved in physical deterioration?	N:5
How do changes in relative humidity cause physical deterioration?	N:5
What effect does weathering have on wooden objects?	N:6
What types of deterioration are attributed to human abuse?	N:6
What are the agents of chemical deterioration?	N:7
What are the biological agents of deterioration?	N:7
D. The Nature of Furniture	N:9
What are the common types of joinery?	N:9
What should I know about metal fasteners?	N:10
What types of adhesives are used in creating wooden furniture and other objects?	N:11
What is veneer and what are the problems associated with it?	N:11
Why are finishes applied to furniture and wooden objects?	N:12
What types of finishes are used?	N:12
What is patina?	N:13
What happens to finishes as they age?	N:14
What should I know about the hardware on wooden furniture?	N:14
What potential sources of damage should I look for in upholstered furniture?	N:14
Should I ever replace the upholstery?	N:15
E. Preventive Conservation: Controlling the Environment	N:15
What elements of the environment should be controlled?	N:15
What is the ideal relative humidity for furniture and other wooden objects	N:15
Why is temperature important?	N:16
What effect does light have on wooden objects?	N:16
How can I control ambient air quality?	N:16
F. Preservation Through Good Housekeeping Practices	N:17
What housekeeping practices should I follow?	N:17
What are the best ways to remove dust?	N:17
Do furniture and wooden objects require more than thorough dusting?	N:18
Should furniture be waxed?	N:18
What kind of wax should I use?.....	N:18
What precautions should I take when waxing furniture?	N:19
How often should I apply wax?.....	N:19
What is the recommended method of applying wax?.....	N:19
What commercial brands of wax can I use?.....	N:20
How do I care for the hardware on wooden furniture?	N:20

G. Preventive Conservation	N:20
How can I provide a protective environment for wooden objects in storage?	N:20
What is the best way to move large pieces of wooden furniture?	N:21
What should I do if a part of the wooden piece becomes loose or falls off?	N:22
Is there a special technique for removing mold from wooden objects?	N:22
How can I determine if a wooden object has an active beetle infestation and what should I do about it?	N:23
H. Conservation Treatment	N:23
How do I assess the stability of a wooden object?	N:23
How should I document the condition of furniture and wooden objects?	N:24
What will a conservator do in the course of treating wooden objects and furniture?	N:25
I. Emergency Procedures for Wooden Objects	N:26
What is the most common type of emergency?	N:26
What preservation problems will I encounter during a flood?	N:27
What should I do in the event of a flood?	N:27
J. Selected Bibliography	N:28

List of Figures

Figure N.1. The Three Principal Planes or Surfaces of a Typical Block of Wood: Tangential, Radial, and Cross Section.....	N:3
Figure N.2. Graph illustrating the Relationship Between Relative Humidity and Equilibrium Moisture Content of Wood	N:4
Figure N.3. Characteristic Shrinkage and Distortion of Wood.....	N:6
Figure N.4. Typical Mortise and Tenon Joint.....	N:10
Figure N.5. Typical Dovetail Joint.....	N:10
Figure N.6. Common Veneer Applications	N:12
Figure N.7. Proper Techniques for Moving Furniture	N:22

APPENDIX N: CURATORIAL CARE OF WOODEN OBJECTS

A. Overview

- 1. What is covered in this appendix?*

This appendix deals primarily with the preventive conservation of wooden objects on exhibit and in storage. It discusses proper environmental conditions and details housekeeping procedures. In order to provide an understanding of how and why wooden objects react to the environment and to human intervention, the appendix includes:

 - a discussion of the nature of wood
 - typical fabrication techniques of wood objects, furniture, and associated materials
 - types of deterioration that affect objects made of wood
- 2. What types of wooden objects are found in museum collections?*

Park museum collections contain wooden objects in a wide range of forms:

 - utilitarian objects, such as tools and farm vehicles
 - religious objects, such as icons and altars
 - furniture, significant for historical or decorative reasons

A large percentage of objects in NPS collections are composites—articles made of more than one type of material. Composite objects include:

 - frames that house prints, documents, and paintings
 - musical instruments
 - rifles
 - machinery, such as sewing machines and cameras
- 3. How much care do wooden objects require?*

Both the nature of individual objects and how they are exhibited dictate how much and what kind of care is needed. Wooden objects are found under a wide range of exhibit and storage conditions.

 - Furniture often is in open exhibits in furnished historic structures.
 - Vehicles, totem poles, and gun carriages frequently are on exhibit outside, where they are exposed to the weather.
 - Smaller objects may be more carefully exhibited in display cases in visitor centers and museums.
- 4. Should I provide on-site care myself or contact a conservator?*

This appendix includes a discussion of how you can assess the condition of wooden objects and when to seek the advice of a conservator.

B. The Nature of Wood

To understand the behavior of wood and its requirements for long-term preservation, you should be aware of the physical and cellular structure of a tree. You will then know why wooden objects react to particular environmental conditions. Some wooden objects from prehistoric sites, such as tools from dry caves in the Southwestern United States, remain in excellent condition, while other wooden objects deteriorate rapidly. The condition of these objects depends on the type of environment in which they were housed.

1. *What is the structure of a tree?*

A tree can be described as a bundle of vessels, its walls composed of cellulose glued together with lignin. New cells grow around the circumference of the tree, forming a ring just within the bark. Wood cells are longer than they are wide and are oriented parallel to the long axis of the trunk and branches. The term *grain* in this appendix refers to the direction of the vessels. “Cross grain,” then, refers to the horizontal plane, while “along the grain” refers to the vertical plane.

Looking at the end of a log or a cross-section of a tree, you can see an inner and an outer zone. The outer zone called *sapwood* is lighter than the inner or *heartwood* zone. These two zones serve distinct functions in the living tree and have very different characteristics that influence the behavior of wood even after it has been fashioned into objects. Sapwood is composed of newer living cells, which transport sap or water to the leaves and which store nutrients. As sapwood ages and becomes heartwood, *extractives* form within the cell walls, giving it color, durability, and dimensional stability. The chemical defenses found in the extractives help protect heartwood lumber from biological attack. Lumber from sapwood has no such protection.

2. *What are the three planes common to trees and lumber?*

Lumber has three planes, which are illustrated in Figure N.1:

- cross section
- radial section
- tangential section

The surface exposed in a cross-section is referred to as *end grain*. Because the cell cavities are exposed in end grain, water is both easily absorbed and given off. The surface is hard and prone to splitting. It does not take stain or finish well and cannot be sanded smooth.

The radial plane extends along the long axis of the tree, more or less perpendicular to the growth rings. The grain pattern on this vertical or edge grain is usually straight and regular. Boards cut along this plane are dimensionally stable and distort very little in response to changes in ambient relative humidity. They will also stand up to abrasion and weathering.

The tangential plane extends along the long axis of the tree and forms a tangent with the concentric growth rings. Boards cut along this plane will swell, contract, and become distorted at twice the rate of those cut on a radial plane.

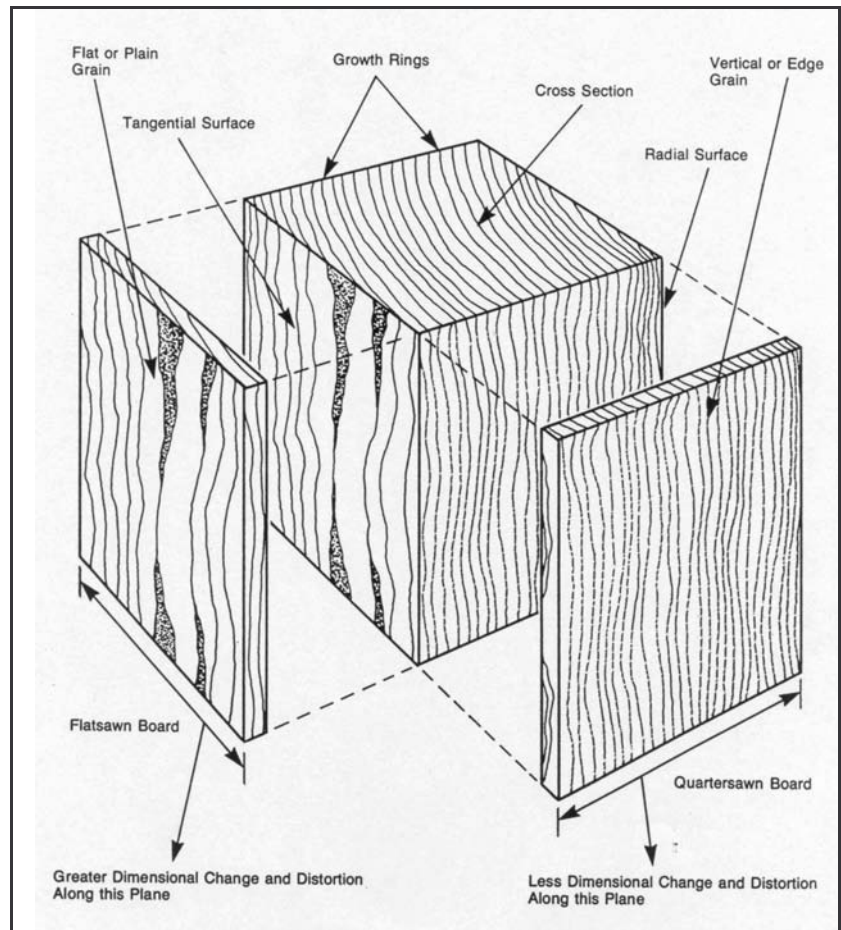

Figure N.1. The Three Principal Planes or Surfaces of a Typical Block of Wood: Tangential, Radial, and Cross Section

3. *What effect does water have on wood?*

There is a very strong molecular attraction between water and the cellulose in wood (called *hygroscopicity*). In freshly cut wood, water is found in both vessel cavities and cell walls. As the wood dries, the water in the cavities evaporates, but as long as the bound water remains in the walls, the wood will stay at the *fiber saturation point* and will not shrink. The moisture content at saturation is about 25%. When below this point, the wood will respond to changes in ambient relative humidity. Air-dried wood will reach a moisture content of 10%-12%, while kiln-dried wood will reach a moisture content of about 7%. This kiln-dried wood or the objects fashioned from it will absorb water vapor if placed in an environment with high relative humidity.

Wood will eventually arrive at equilibrium with its environment, neither absorbing moisture (swelling) nor giving off moisture (shrinking), as long as the RH remains constant. See Figure N.2 for a graph that illustrates the relationship between relative humidity and equilibrium moisture content in wood. This graph can help you calculate the amount of contraction or expansion that may occur in wooden objects.

When moisture is absorbed and released, the cell walls expand and contract. The cell length, however, remains nearly unchanged. Therefore,

dimensional change in wood is not uniform in all planes (see Figure N.1). While movement **along** the longitudinal plane (the long axis of the tree) is negligible (only about .1%), movement **across** this plane is significant. Along the tangential plane, dimensional change is the greatest, averaging about 8%. Along the radial plane, dimensional change averages about 4%.

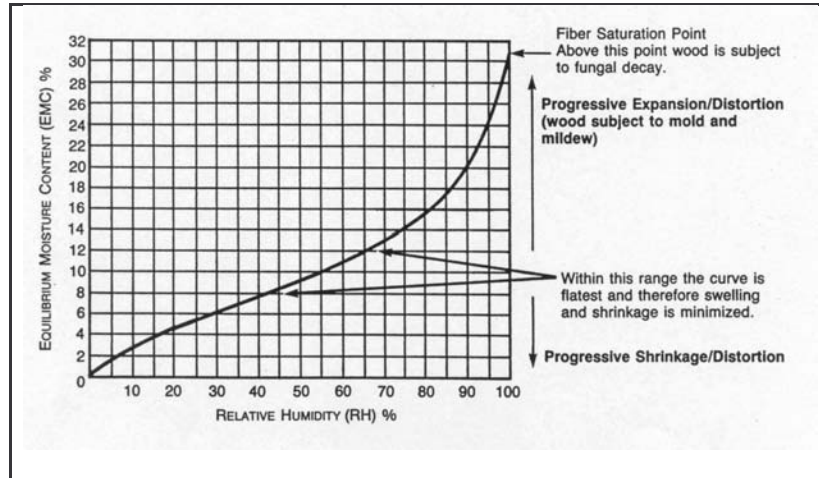

Figure N.2. Graph Illustrating the Relationship Between Relative Humidity and Equilibrium Moisture Content of Wood

4. *Do all types of wood react in the same way?*

No. The extent of dimensional change varies from species to species, making some kinds of woods more desirable in the making of furniture and wood objects. Teak, mahogany, and redwood are among the more stable woods. Walnut and cherry, popular woods with furniture makers, fall in the middle of the range.

5. *Where is the difference in dimensional change evident in museum objects?*

The rim of a turned bowl over time will move out of round, becoming slightly oval in shape because of the difference between tangential and radial shrinkage. For the same reason, turned feet become oval, and square legs take on a diamond shape on many pieces of furniture. Rungs and stretchers may become loose in chair legs because of the differential in shrinkage along and across the grain. Veneered surfaces may split or buckle because the grain orientation of the veneer is different from that of the underlying wood.

C. Agents of Deterioration

Wood decays both in nature and in museums as a result of:

- physical deterioration
- chemical deterioration
- biological deterioration

1. *What's involved in physical deterioration?*

There are three direct causes of physical deterioration.

- changes in relative humidity
- weathering
- human abuse

2. *How do changes in relative humidity cause physical deterioration?*

Shrinking and swelling, caused by changes in relative humidity, have been addressed in the discussion of the nature of wood. Because this reaction is not uniform across all planes, boards may become distorted or warped. The type of distortion will usually depend on the shape of the board and the orientation of the wood cells. See Figure N.3 for an illustration of characteristic shrinkage and distortion.

- *Cupping* is a deformation across the width of a board. It is often observed on wide, unrestrained boards, such as leaves on a drop-leaf table. This cupping can occur in the initial seasoning or later on in the life of an object. It can sometimes be caused by applying finish to only one side of the board. It may also occur when different microclimates are present on opposite surfaces. For example, the surface of a table leaf in the sun or near a radiator will become dryer than the surface underneath.
- *Checking* is also a result of uneven shrinkage. Stress can cause cells along the grain to separate, usually at the end grain or near the surface. Checking usually occurs during the initial seasoning, however, it can also occur if the relative humidity drops rapidly. Checks may extend just a short distance, causing only visual damage to the object, or they may extend an inch or more into the board causing actual structural damage.
- *Radial cracking* almost always occurs in logs that are left to dry. A pie-shaped crack will open from pith to bark edge to relieve the stress caused by the differential in shrinkage between the radial and tangential planes. Wood used in making objects that require a wide cross section, such as large bowls and three-dimensional sculpture, must be dried very slowly and carefully. Even with this precaution, the objects will always be prone to radial cracking.
- *Diamonding* is caused by the difference between tangential and radial shrinkage. A piece of lumber originally square (or rectangular) in cross section will become diamond-shaped.

A straight-grained, unrestrained board can usually withstand moderate fluctuations in relative humidity without damage. Because furniture is often made from various members that are connected across grain and are restrained from natural expansion and contraction by glue and nails or screws, the stress can become strong enough to cause the wood to split.

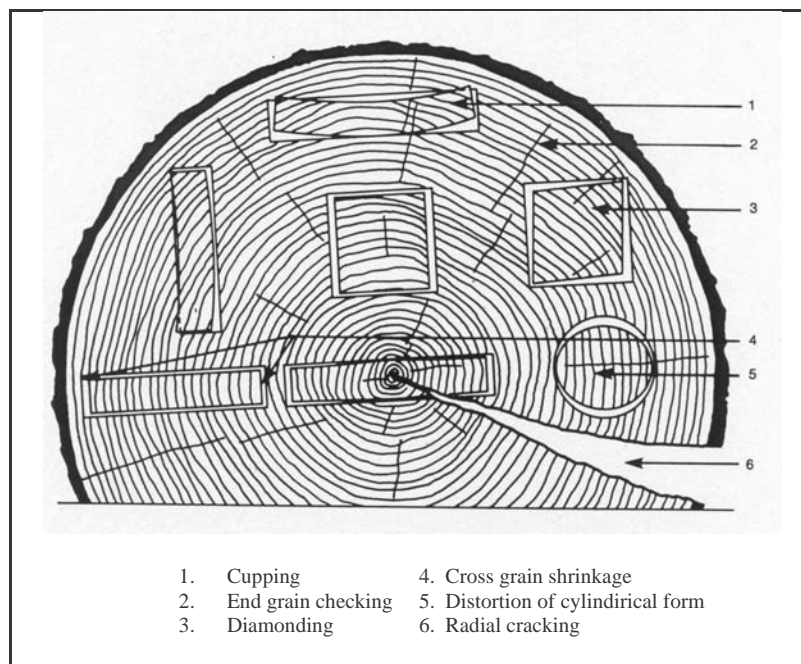

Figure N.3. Characteristic Shrinkage and Distortion of Wood (Viewed from the Transverse Plane)

3. *What effect does weathering have on wooden objects?*

Wooden objects housed outdoors are subject to physical erosion from the action of rain and wind-driven particulates, though that erosion generally does not exceed ¼ inch of unprotected wood surface per 100 years. The weathering process also includes photochemical degradation. The wood surface generally takes on a silver-gray color and a striated texture as the softer earlywood wears away and the harder latewood is exposed. Ultraviolet light breaks down the lignin in the cell walls, which is then washed away by the rain. The silver-gray surface, which is only a few millimeters thick, is actually more resistant to biological attack than non-weathered surfaces.

Many wooden objects now in indoor museum collections spent their useful life outdoors. As long as the objects are free of fungal and insect damage, the weathered condition can be considered stable and the appearance should be preserved as part of the historical evidence.

4. *What types of deterioration are attributed to human abuse?*

Physical damage to wood objects in museum collections can result from improper handling and housekeeping procedures, and poor storage or exhibit conditions. Physical damage will occur more often in collections exhibited in furnished historic structures where the objects are exposed to more soils and dust in the environment and therefore require more frequent cleaning.

Poorly done repairs are another common cause of damage to wooden objects. Nails may split the wood and mar the surface; glue may leave misaligned surfaces and residue; original finishes may be removed mistakenly. Future conservation treatment may be made more difficult by the use of irreversible materials.

5. *What are the agents of chemical deterioration?*

There are five basic agents of chemical deterioration:

- **Light** causes deterioration of the cellular structure of wood, breaks down the lignin component, and bleaches its colors. The most harmful component of light is ultraviolet (UV) radiation. Light damage to wooden objects in furnished historic structures is most commonly caused by sunlight streaming through unshaded windows. It can also occur from excessive artificial light used to illuminate exhibits. Not only is light harmful, but the heat it generates also does damage, especially when lighting fixtures are placed inside exhibit cases.
- **Acids** may deteriorate the cellulose in wood causing it to become brittle. Acid rain on outdoor objects can be a problem.
- **Alkalies or bases** degrade the hemicellulose and lignin component of wood and cause the wood to separate into individual fibers. Alkaline solutions are more damaging, as a rule, than acidic solutions.
- **Salts** can also result in defibration of the wood tissue, but exposure to salt is less common. It may be seen in wooden objects used in food preparation and in objects exposed to a maritime environment.
- **Fire** is the most dramatic and by far the most damaging form of chemical deterioration. Wood is a readily flammable material.

6. *What are the biological agents of deterioration?*

Wood is subject to deterioration from a number of biological agents. Damage to wooden museum objects often occurs before the object is placed in the museum setting and may happen even before the wood is sawn into lumber.

- **Bacteria**, which consumes the starches stored in ray cells, generally affects only water-saturated wood and is therefore not a problem in most museum collections. However, wood that has been made more permeable by bacteria previously can be vulnerable to fungal activity.
- **Fungi** cause more biodeterioration in wood than any other agent. Because fungi have no chlorophyll, they must live on other organic material. The plant consists of thin, thread-like material called *hyphae* that mat together to form *mycelium*. Fungi produce large numbers of *spores*. Three types of fungi affect wood:
 - *Mold fungi* live principally on the surface of wood and discolor it. However, they don't consume cellulose and therefore don't weaken the wood.
 - *Stain fungi* invade the cell structure of sapwood and live on stored carbohydrates.
 - *Decay fungi* actually consume the cellular structure of wood, totally destroying it in some cases. These fungi produce enzymes that break down the cells. The two major types of decay-causing fungi are brown rot and white rot. Brown rot consumes cellulose, leaving a brown color and checking both along and across the grain. White rot consumes both cellulose and lignin, causing the

wood to lose color and crack along the grain. Decay fungi, consequently, cause abnormal shrinkage of wood tissue.

Fungal spores are found in virtually every environment. In order to germinate, however, they require air, heat, moisture, and nutrients. By controlling these conditions you can prevent fungal growth on wooden objects in your collection. Ideally, relative humidity should be kept between 45% and 55%. RH must never exceed 65%.

Temperatures high or low enough to effectively stop fungal growth are impractical in a museum. However, maintaining a temperature of 68° F or below will retard the growth of mold. Decay fungi are problems only when the moisture content is at or above the fiber saturation point. The wooden object would have to be in contact with water to reach a moisture content over 30%. See *Conserve O Gram* 3/4, Mold and Mildew: Prevention of Microorganism Growth in Museum Collections, and Chapter 4: Museum Collections Environment.

- ***Insects*** both feed on wood and excavate it to shelter themselves. See Chapter 5: Biological Infestations, for a lengthier description of wood pests and instruction in integrated pest management.
 - *Beetles* do the most damage to furniture and wooden objects, particularly in temperate climates and an environment of high relative humidity. The adult lays its eggs in pores or checks in the wood surface. After the eggs hatch, the larvae excavate tunnels through the interior of the wood, eventually pupate, and then bore holes to the surface to fly off. The larval stage may last up to 10 years.
 - *Termites*, though less of a problem than beetles, can do considerable damage to stationary structures. Drywood termites, found primarily along the southern and southwest coasts of the U.S., do not need moisture and feed on the dry wood they infest.
 - *Carpenter ants* do not eat wood, but excavate large chambers for their colony.
 - *Carpenter bees* bore large chambers and use them for their eggs, but do not actually consume the wood.
- ***Marine organisms*** are a significant problem in wooden ships and other underwater artifacts. *Shipworm* and *gribble* are two of the most destructive marine organisms. Shipworm is a mollusc that lives on wood and plankton and makes channels in the wood up to 2.5 cm in diameter. Gribble is a small crustacean, barely 1/8" long, that tunnels narrow channels close to the surface of the wood.
- ***Rodents*** damage wood by their gnawing to get food and salts from the surface of wood or to get through to the food stored within. Museum furniture, such as pie safes and jelly cupboards, may have large holes through their backboards. Wooden food vessels that may contain food remnants on the surface or in the pores are vulnerable to rodent damage. Removing the food, however, also removes important evidence of historical or cultural use.

- **Birds**, mainly woodpeckers, are a threat to outdoor wooden objects. They are drawn to wood that may have insect infestations.

D. The Nature of Furniture

Most furniture originally served both functional and decorative purposes. Once in a museum collection, furniture no longer needs to be functional. The conservator and curator, therefore, focus on preserving the decorative and historical aspects of the piece. A single piece of furniture may be formed from several components, each requiring special knowledge and treatment. These components may include joinery, metal fasteners, adhesives, veneer, finishes, hardware, and upholstery.

1. *What are the common types of joinery?*

Almost all furniture is made from two or more pieces of wood, joined together in some fashion.

- The **mortise and tenon** joint is one of the most common and earliest joints used in furniture construction. The mortise is a hole chiseled into a piece of wood, while the tenon is the projection on the end of another piece of wood that fits into the mortise. Because these two pieces of wood are at cross grain to one another, different degrees of expansion and contraction can cause problems. The tenon should be slightly smaller than the mortise to prevent the mortise from splitting. These joints are typically held together with glue, though in country pieces, it was common to drive square pegs into round holes drilled through the joint. See Figure N.4 for an illustration of a typical mortise and tenon joint.
- **Frame and panel construction** prevents the splitting that often results when wide boards are constrained at their edges. In this technique the frame is made from relatively narrow boards joined at the corners with mortise and tenon. The inner edge of the frame is grooved to hold the edges of a wide panel, which is free floating and therefore able to expand and contract freely with changing relative humidity.
- The **dovetail joint** is another traditional technique, generally used to join the edges of wide boards. The edges are cut and chiseled so that they interlock. This technique was typically used on the sides of drawers and chests. Dovetail joints are commonly glued. See Figure N.5 for an illustration.

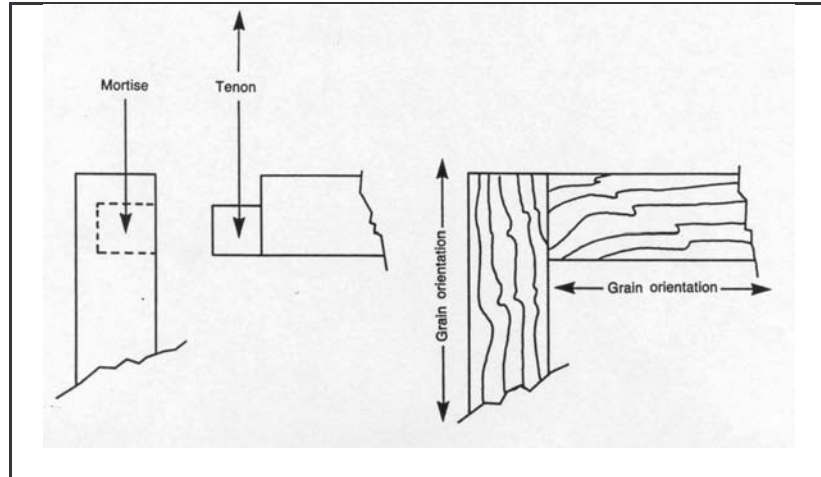

Figure N.4. Typical Mortise and Tenon Joint

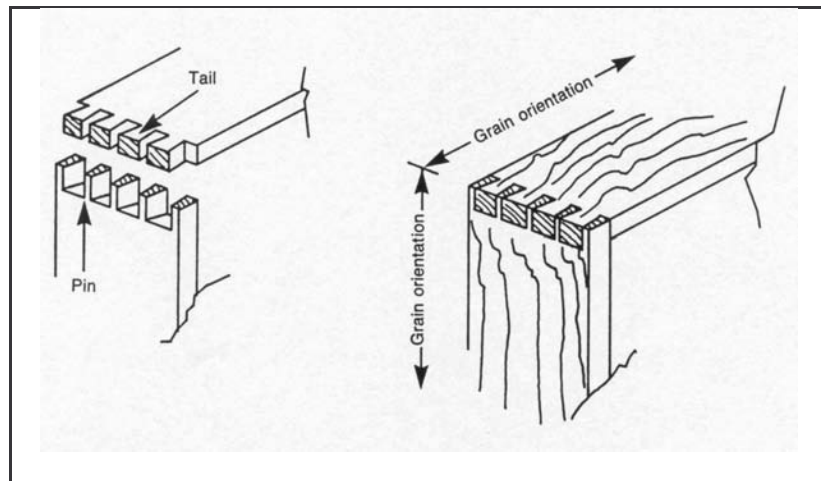

Figure N.5. Typical Dovetail Joint

2. *What should I know about metal fasteners?*

Various types of metal fasteners have been used in furniture construction, including nails, screws, and bolts. Hardware can be useful in dating furniture. For example, nails became more frequently used when they were first mass-produced in the late 1700s. Screws were not commonly used until the 1840s, when the technology to manufacture them with gimlet points was developed. (A gimlet point is one that can readily penetrate wood.)

Fasteners are most often made from ferrous metals, which corrode in high relative humidity. This corrosion can spread, damaging the appearance and structure of the wooden object. Severely corroded metal will expand, crushing and splitting the surrounding wood. *Corrosion jacking* is most likely to occur at the coast, where there is exposure to salts in the environment. Iron salts, often present at contact points between wood and ferrous metals, degrade and discolor wood. Woods with high tannic acid levels, such as oak, are very susceptible to damage from iron salts. Contact between some woods and metals also will accelerate the oxidation of the metal.

3. *What types of adhesives are used in creating wooden furniture and other objects?*

Adhesives, used alone or in conjunction with fasteners, come in three basic types:

- **Protein-based glues**

Animal products are the primary ingredients in protein-based glues. Historically, the two most commonly used varieties were hide glue and fish glue. These were heated to a gel before use. The glue set as it cooled and the water content evaporated. Because this type of glue is readily resoluble and has a long setting time, it is often used in the conservation treatment of furniture and other wood objects.

Though strong in a proper environment, protein-based glues are water-soluble and therefore fail in high relative humidity. At the other extreme, very low relative humidity, the glue will dry and crack causing the joint to fail. Casein glue, made from milk curds, is occasionally found in furniture and wood objects. It is more resistant to the effects of moisture than the other protein glues. Another disadvantage of these substances is the attraction they hold for insects.

- **Vegetable glue**

Vegetable glues, such as starch paste, though seldom used for gluing wood joints, can be found adhering paper labels or paper coverings to wooden surfaces. Other types of vegetable glues, like gums and resins produced by trees, are commonly found on ethnographic wooden objects, but not in Western furniture. Like hide and fish glues, vegetable glues are sensitive to changes in relative humidity and are susceptible to biodeterioration.

- **Synthetic resins**

Synthetic resin adhesives have become increasingly common since the 1940s. They harden either through the evaporation of a solvent, like water, or a chemical reaction between a hardener and a resin. Many post World War II objects in museum collections are constructed with these adhesives. Most synthetic resins form a very strong bond, are durable, and are relatively insensitive to environmental conditions. These qualities become disadvantages when objects need conservation treatment for it is nearly impossible to separate these joints without causing damage to the wood surface.

4. *What is veneer and what are the problems associated with it?*

Veneer is a thin layer of wood glued to a solid base material for decorative purposes. It ranges in thickness from 1/32" to 1/8". Older veneers were sawn by hand and are thicker than contemporary ones and often irregular. They were often attached with hide or fish glues. Expensive woods (for example, rosewood and mahogany) are typically used for veneering. Many small pieces of veneer are used in marquetry, inlay, and banding to create intricate patterns and pictures.

Generally the grain of the veneer on tabletops and other large, flat surfaces lies in the same direction as the grain of the underlying wood. In other areas the grains may lie perpendicular to each other, or as in marquetry and inlay, at almost any angle. Fluctuating humidity levels can cause severe damage as the woods expand and contract along different planes. See Figure N.6 for common applications of veneer.

Some areas of veneered furniture are more likely than others to receive damage. For example, the veneer on drawer rails and the bottom rails of case furniture, such as chests and sideboards, is very vulnerable. As the underlying wood shrinks, a lip of veneer forms along the top and bottom edges. The drawer, as it moves in and out, can easily snag the protruding veneer and tear it off. Dust cloths can catch on loose veneer and pull off pieces. Mops, brooms, and vacuum cleaners often cause irreparable damage to the lower edge of bottom rails during routine housekeeping.

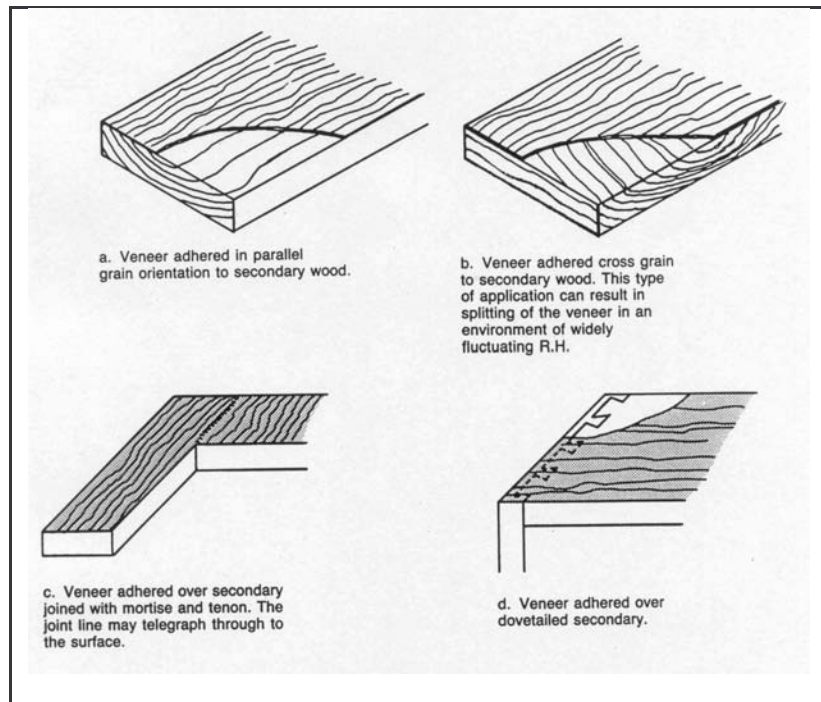

Figure N.6. Common Veneer Applications

5. *Why are finishes applied to furniture and wooden objects?*

Stains and dyes are often applied to wood to enrich or darken the color. They penetrate the surface but do not leave a film. Alcohol- and water-based stains are sensitive to light damage. Oil-based stain is more resilient.

Transparent or pigmented finishes are applied to wood for more than one reason. They are used aesthetically to bring out the color and grain pattern. In other cases the finish may be strictly utilitarian. They preserve the wood by protecting it from spills and light damage and by slowing the transfer of water vapor from the environment.

6. *What types of finishes are used?*

Among the most common finishes found on museum pieces are varnish, oil, shellac, wax, paint, and gilt.

- **Liquid finishes**, including varnishes, oils, and shellacs, are divided into three broad categories: resins, polymers, and paints.
 - *Resins*, such as spirit varnishes, are either dissolved or dispersed in solvent. They harden as the solvent evaporates. Shellac is made from the resinous secretion of insects and is the most common finish found on furniture in park museum collections. It was

particularly popular in the 19th and early part of the 20th centuries. Resins are susceptible to damage from water and alcohol.

- *Polymers*, which include most oil finishes, harden by means of chemical bonding (polymerization) and/or oxidation. Linseed oil and tung oil are commonly used oil finishes. They penetrate the wood but do not provide as hard a finish as resins. Linseed oil, particularly, darkens over time as it oxidizes. Misused in the past, in combination with turpentine and beeswax, it has caused damage to many museum pieces. Though serviceable in moderation, in excess linseed oil remains tacky, gathers dust, and severely darkens the wood. Oils are very difficult to remove without damaging the underlying finish. **Do not apply oil to finished wooden surfaces.**
- *Paints* consist of pigment particles in suspension in a binding medium and a solvent. Most paints are relatively stable, however, calcimine and distemper used during the eighteenth and nineteenth centuries were made with a protein glue binder and therefore dissolve in water. **These soluble finishes should be dusted only.**

A few finishes, such as oil-resin varnishes, are a combination of the two.

- *Waxes* are softer and more plastic than other finishes and are readily soluble in most organic solvents. There are few, if any, examples of objects with original wax finishes in park museum collections. **Do not clean a wax finish as you would a hard finish.** Consult a conservator for advice.
- *Gilt* may have been used as a decorative accent on furniture or as a finish over the entire surface. It was most commonly used on ornate picture frames. A gilt finish consists of a gesso layer, a sizing layer, and silver or gold leaf that is metal-hammered into extremely thin sheets. Silver and lesser grades of gold oxidize rapidly. Sometimes the leaf was painted with pigmented shellac to protect it.

Gilt is the most fragile of all finishes, extremely susceptible to damage from rough handling and improper housekeeping. Skin oils can accelerate oxidation, so do not touch the gilt surface. The gesso layer is brittle and often cracked from the expansion and contraction of the underlying wood. Under very humid conditions the gesso will absorb enough water vapor to soften and expand so that it eventually chips away from the wood. **Dust these surfaces gently with a soft bristled brush and a low power vacuum held at least 1/2 inch away.**

7. What is patina?

Patina refers to the distinctive appearance of older finishes. It is used to describe a worn finish, but one with warm tones and satin luster. There is a fine line between patina and a damaged finish. It is important to recognize and protect an unstable finish that may deteriorate further under the existing environmental conditions.

8. *What happens to finishes as they age?*

The aging qualities of finishes vary. Oriental lacquer, for example, is very sensitive to moisture and light damage. Shellac, on the other hand, is relatively resistant to light damage because it allows the light to pass through and consequently harm the stain and wood beneath.

All finishes are damaged to some extent by exposure to high light levels because light accelerates oxidation. Oxidation prevents the finish from expanding and contracting freely with the wood beneath. Minute cracks, called crazing or “alligatoring,” may result. Some light-damaged finishes are dull and chalky, while other more severely damaged finishes become unstable, flaking or breaking down into “islands” that lift at the edges.

Fluctuating relative humidity will worsen the condition of finishes made unstable by exposure to high levels of light. High humidity can cause white “blooms” and mildew damage on even stable finishes.

9. *What should I know about the hardware on wooden furniture?*

Drawer pulls, knobs, escutcheons, locks, and other types of hardware are typically made out of brass on decorative pieces and ferrous metal on functional pieces. Brass, an alloy of copper and zinc, will dull and darken as it oxidizes. Polishing brass can damage both the hardware and the surrounding wood. Rubbing with abrasive polishes eventually will wear away the surface of the brass. If the hardware is not removed from the piece for cleaning, the wood finish around and beneath the hardware will likely be damaged or even entirely worn away. Hardware that is not washed after polishing will often show a white or green residue. Green residue indicates the presence of ammonia, which will continue to react with the brass.

Pigmented shellac frequently was applied to brass to protect the shine and give it a more golden tone. This coating, however, is easily scratched. Occasionally the brass on very decorative pieces was given a thin coating of gold in a process called fire gilding. This bright, shiny gold layer will prevent oxidation, but like the shellac is easily damaged. Do not clean fire-gilded brass until you have consulted a conservator.

10. *What potential sources of damage should I look for in upholstered furniture?*

Like wood, upholstery is subject to deterioration from:

- high temperature, which can leave the fabric brittle
- high humidity, which promotes biological activity
- visible and ultraviolet light, which causes all fabrics to fade
- chemical reactions
- bacteria and fungi
- mechanical abuse
- termites and woodworms
- rodents

In addition, look for deterioration from agents that more typically attack textiles. See Appendix K, Section D, for a comprehensive discussion of these:

- pollution, such as dirt and pollen, industrial emissions, and smoke
- fiber-eating insects, such as moths, silverfish, cockroaches, and carpet beetles
- inherent vice, particularly the addition of metallic compounds during manufacture
- oxidation, which discolors white and natural cloths

See *Conserve O Gram 7/4, Upholstered Furniture: Agents of Deterioration*, for a more thorough discussion.

11. *Should I ever replace the upholstery?*

Yes, under certain circumstances. An upholstered piece in a museum collection may have been re-covered several times during its period of use. The current upholstery fabric may not be appropriate for the period of interpretation or it may be very worn. Because the wood frame might have been damaged by repeatedly attaching the upholstery with tacks, consider using a non-destructive technique when re-covering the piece. See Calinescu and others (1996), for an example of a low-interventive upholstery technique.

**E. Preventive Conservation:
Controlling the Environment**

1. *What elements of the environment should be controlled?*

To provide a stable environment for wooden objects, control these factors:

- relative humidity
- temperature
- light
- ambient air quality

2. *What is the ideal relative humidity for furniture and other wooden objects?*

The ideal relative humidity level in most areas of the country for wooden objects is 50% plus or minus 5%. In dry climates, such as the southwest, 35% to 40% is acceptable. These levels are difficult to achieve in very dry climates because the moisture content in wood drops rapidly below 35% RH, causing splits. Below 30% the glue may desiccate, joints may loosen, and finishes will become brittle. Along the coast, 55% to 60% is acceptable, but above 70% mold and insects may become problems. When humidity is this high, glue may weaken, finishes may bloom, hardware will corrode, and wood fibers will swell excessively.

Rapid changes in relative humidity, as mentioned earlier, may cause severe damage to furniture. An increase in RH from 30% to 70% can cause wood to expand as much as 2% across the grain. In this case a 2-foot panel could expand almost 1/2 inch causing splitting, veneer loss, and joint failure.

Avoid temporarily heating, air conditioning, or humidifying spaces that house wooden objects. Do not turn off heat or air conditioning at night.

3. *Why is temperature important?*

Temperature is important primarily because it affects relative humidity. Though changes in temperature alone also will cause some expansion and contraction of wood, this is a relatively minor concern. Elevated temperatures will speed fungal and insect activity as well as oxidation. High temperatures associated with high relative humidity can cause some old finishes to become tacky.

- Consider installing a humidistat to override the thermostat in spaces housing wooden objects.
- Maintain the temperature at the lowest comfort level in exhibit areas and even lower in storage spaces, but be sure to keep it above freezing at all times.

4. *What effect does light have on wooden objects?*

Light will change the natural color of heartwood, making light woods darker and dark woods lighter. It will fade stains and embrittle finishes. It also will fade and embrittle the fabric or leather on upholstered furniture. The level for unfinished wooden objects should not exceed 300 lux. The light level for most finished wood objects should not exceed 200 lux. Objects decorated with fugitive stains and dyes and light sensitive fabrics, such as silk, are more prone to light damage and the allowable light level should be even less.

Limit exposure of wooden objects to both natural and artificial light:

- Install UV filters on windows and florescent lamps to reduce most of the harmful UV radiation.
- Use blinds, shutters, curtains, and roller shades in historic structures to reduce visible light.
- Use reproduction slipcovers to protect upholstered furniture.

5. *How can I control ambient air quality?*

Most modern museums have a variety of filters in their HVAC systems to clean the air and filter out dust and other particulates. In addition, many objects in these buildings are displayed in protective exhibit cases. Historic structures, on the other hand, seldom have good air filtering systems and the furniture is displayed openly. More particulates are generated simply because of the nature of the buildings. Not only is dust abrasive and therefore harmful to wooden surfaces, it is a source of food for mold and is attractive to insects.

F. Preservation Through Good Housekeeping Practices

1. *What housekeeping practices should I follow?*

The conditions in historic furnished structures require intensified housekeeping both in procedure and frequency. Good housekeeping is essential for aesthetic and preservation reasons. It should be carried out on a regular schedule. See Chapter 13: Museum Housekeeping, to learn about developing a museum housekeeping plan.

Keep this tip in mind when handling wooden furniture and objects:

Don't wear gloves when handling furniture with fragile veneer that might snag or when moving heavy wooden pieces requiring a sure grip. **Do wear them** when handling gilt finished objects or unfinished objects made from light colored wood that might stain.

Frequent and proper housekeeping is critical for the preservation of collections in historic structures.

2. *What are the best ways to remove dust?*

Because dust is not only abrasive but also attracts moisture, it should be removed periodically to prevent damage as well as to improve the appearance of objects. Remove it from the environment as completely as possible.

- **Use a vacuum** to remove the dust from wood surfaces if possible. (See *Conserve O Gram 7/5*, Dusting Wooden Objects, and *Conserve O Gram 1/6*, Choosing a Vacuum Cleaner for Use in Museum Collections.) Hold the brush attachment just above the wood surface. Use a soft bristled brush to sweep the dust out of crevices and intricately carved areas and toward the vacuum brush. Also vacuum upholstery. (See Appendix K for guidance.) **Keep the vacuum clean.**
- **Use a clean cotton cloth** when vacuuming is not an option. Turn the cloth frequently so that accumulated dust does not scratch the object's surface. Wash the cloth after every use. You may dampen the cloth with water or spray it sparingly with a light mineral oil product, such as Endust®, where low relative humidity creates a static charge, causing the cloth to repel the dust. If using water, be sure to dry the surface immediately. **Do not** use scented oil products.
- **Don't use feather dusters.** They scatter the dust rather than collect it. Broken feathers may scratch the surface.
- **Don't wipe unstable finishes.** This will cause more harm to flaking and lifting edges or surfaces that have loose veneer or splintered corners.
- **Use compressed air** on very fragile objects and irregular surfaces. Limit pressure to about 10 pounds and use away from exhibit areas.

3. *Do furniture and wooden objects require more than thorough dusting?*

Yes. Periodically these require cleaning to remove oils and grime. Objects in storage may need to be cleaned only every ten years while those on exhibit will require cleaning approximately every three years. More frequent cleaning may be necessary if visitors occasionally touch the pieces.

- Use mineral spirits, such as Stoddard solvent or naphtha, on greasy types of soils and hand oils. First test a small inconspicuous area with a cotton swab dipped in mineral spirits. If the finish does not get tacky and no finish comes off on the swab, you may begin careful cleaning with a cotton cloth dampened with mineral spirits. Work in a well ventilated area and wear vinyl gloves. Turn the cloth frequently and wipe the object down with a clean, dry cotton cloth after cleaning. **Note:** Some 18th century pieces may still have their original wax finish. Consult your regional/SO curator and a conservator before cleaning furniture that you suspect has an original wax finish.
- Use soap like Vulpex[®], Ivory[®], and Orvus[®] and water to remove smoke and soot from stable finishes. Follow manufacturer's instructions for dilution. Never use detergent because it will leave a film on the surface. Again, test a small inconspicuous area before cleaning the entire surface. Wring the cloth well before wiping. When finished, wipe the piece again with a cloth dampened in clear water and then again with a dry cloth. **Do not moisten a damaged, veneered, or inlaid surface.**

Only furniture with a sound finish should be cleaned.

4. *Should furniture be waxed?*

Yes. The application of wax to clear finishes is recommended for these reasons:

- Wax enhances the appearance of the surface by filling in voids and small depressions, creating an attractive level surface.
- Wax helps protect the surface from abrasive dust and handling.
- Waxing makes dusting easier.
- It slows the penetration of water and water vapor, which will cause the wood to swell.

Note: Always re wax the finished surface after cleaning, since mineral spirits will dissolve and remove wax.

5. *What kind of wax should I use?*

The paste waxes recommended for use on wooden objects in museum collections are made with weak organic solvents, such as turpentine or mineral spirits. When the solvent evaporates, the wax film that remains is lustrous, slippery, and plastic. Waxes are derived from animal, vegetable mineral, and synthetic sources. Natural waxes, like beeswax, have been used for centuries. Most commercial paste wax products are mixtures of various waxes.

- **Don't use** paste wax made with strong solvents, such as xylene and toluene, because they can damage some finishes.

- **Don't use** liquid polishes. They do not offer the same protection as paste and most contain silicones. Silicone migrates into the finish and complicates any future conservation treatment.

6. *What precautions should I take when waxing furniture?*

Apply wax only to stable, clear finishes, such as shellac, varnish, and modern lacquer. **Don't** apply paste waxes to unfinished objects because it will penetrate into the pores. Wax applied to unfinished wood surfaces cannot be completely removed.

Cover the upholstered parts of the piece so that you don't accidentally get wax on the material.

Be careful not to get wax into cracks or splits in the wood. Later attempts to repair the crack with glue would be very difficult.

7. *How often should I apply wax?*

The frequency of waxing will depend on environmental factors, such as dust, relative humidity, and light, and on the amount of handling. When museum objects are used or touched, be sure to wax often enough to protect the underlying finish. Most wood objects in furnished historic structures, however, will require rewaxing just every one to four years. Objects in well-gasketed exhibit cases may only require waxing every ten years. As a general rule, rewaxing is not necessary if the existing wax layer can be buffed to a sheen.

8. *What is the recommended method of applying wax?*

Always follow these procedures:

- Clean the object to remove the existing wax. Waxing over dirty surfaces will produce a grimy buildup and eventually obscure the color and grain of the wood.
- Apply new wax sparingly with a clean, cotton cloth, rubbing first in a circular motion and then along the grain. Wait at least an hour or two for the solvent to evaporate and then buff the wax with another clean, cotton cloth. If the luster is uneven, repeat the procedure. **Note:** It is preferable to apply two thin coats rather than a single thick coat.
- On a carved or irregular surface, apply the wax with a soft toothbrush or shoe polish applicator and buff it out with a soft fiber shoe brush. Tape foam padding to the wooden ends of the brush to avoid damaging the object while buffing.
- Don't apply wax when it is hot and humid. The wax may turn white and cloudy. If this happens, remove the wax with mineral spirits and rewax when the environment improves.
- Remove white specks from pores and recesses left by light-colored waxes with a wooden pick or use a pigmented wax on dark wood.

Refer to *Conserve O Gram 7/2, Waxing Furniture and Wooden Objects*, for more guidance.

9. *What commercial brands of wax can I use?*

There are several good paste waxes on the market. These include Staples[®], Butchers[®], SC Johnson[®], and Trewax[®]. Renaissance Wax[®], a good synthetic with no perfumes or pigments, is frequently used on museum objects. It is durable and highly water resistant. It is recommended for smaller wooden objects, however it can be difficult to buff evenly on large, flat surfaces, such as tabletops.

10. *How do I care for the hardware on wooden furniture?*

The best way to care for hardware on museum pieces is to clean and polish it once and then spray it with a lacquer containing corrosion inhibitors. This treatment requires specialized equipment and the experience of a conservator, but applied correctly, the finish should last up to 20 years.

If this conservation treatment is not feasible, the following on-site treatment is the next best solution.

- First, remove the hardware if this can be done without damage. Tag it to document its original location. If it cannot be removed easily, slip Mylar[®] sheets behind the hardware, cutting out slits to get by bolts or nails.
- Determine the type of metal and clean it accordingly.
 - Clean brass hardware with alcohol or Stoddard solvent, if necessary, to remove fingerprints.
 - Soak iron hardware for several days in kerosene to remove rust and dry it thoroughly. Dip badly corroded iron hardware into a metal preservative called Ospho to prevent further deterioration.
 - Softly brush gilded bronze with a weak solution of ammonia and distilled water (1 part ammonia to 40 or 50 parts water). Rinse it with clean distilled water and dry it with a warm, not hot, air-blower.
- After cleaning, you may polish brass hardware with a mild abrasive, such as artist's whiting, that **does not** contain ammonia. **Do not** polish gilded bronze. Be sure to remove all of the polish residue. Use a solvent and wash with distilled water.
- Last, wax all accessible surfaces of the hardware with a microcrystalline wax, such as Renaissance Wax[®]. Wax will retard oxidation, though not as effectively as lacquer.

See Appendix O for further guidance on cleaning, polishing, and coating metal objects.

G. Preventive Conservation

1. *How can I provide a protective environment for wooden objects in storage?*

Protecting objects in storage is much easier than protecting them while on exhibit. First of all, you can eliminate the warm temperatures and light that often cause damage during display. There are a few requirements, however:

- Storage spaces need to be easily accessible. When storing furniture, avoid areas with narrow stairwells and doors.
- Never store wooden furniture directly on concrete, stone, or brick floors. The end grain on furniture legs and feet will soak up moisture, causing fungal damage and staining. Store on shelves or blocks.
- When using storage shelves, place large and heavy objects on the lowest level. (Slotted metal angle storage systems can be adapted for furniture storage. Be sure to pad the edges.)
- Store wood frames on stationary or moveable racks, like those used to store framed paintings.
- Don't stack furniture.
- Don't store objects in the drawers of period furniture.

2. *What is the best way to move large pieces of wooden furniture?*

Because furniture is particularly prone to damage while it is being moved, it is important to carefully plan and execute any move.

- Examine the furniture carefully to detect any structural instability, such as broken or loose joints or splits that may not stand the stress of moving.
- Secure doors, drawers, and drop lids or leaves before moving the piece. Use cotton twill tape rather than twine to avoid scratching the finish. **Never use adhesive backed tape.** Remove drawers if weight is an issue.
- Remove marble tops and store them on edge while you move the base. Large marble tops may fracture from their own weight if held horizontally and supported only at the ends.
- Plan your route and measure doorways, stairways, and aisles along the way to make sure the object and the carriers will fit. (Measure the width of a couch or large chair by placing it against a wall and measuring from the wall out to the middle of the seat rail.)
- Use a dolly.
- Don't attempt to move heavy or awkward objects by yourself.
- Never slide furniture across the floor. Sliding puts too much stress on joints and fragile areas and can cause the feet or legs of dressers, tables, chairs, etc. to break.
- Grasp furniture for lifting where it is strongest, usually the lowest horizontal structural member. For example, lift a table by its apron, a case piece by its bottom rail, and a chair by its side seat rails, being careful not to dislodge the slip seat. Never lift a sofa by its arms—grasp the bottom rails, instead. Moving a particularly large and heavy sofa may require four people.

See Figure N.7 below for the proper moving techniques.

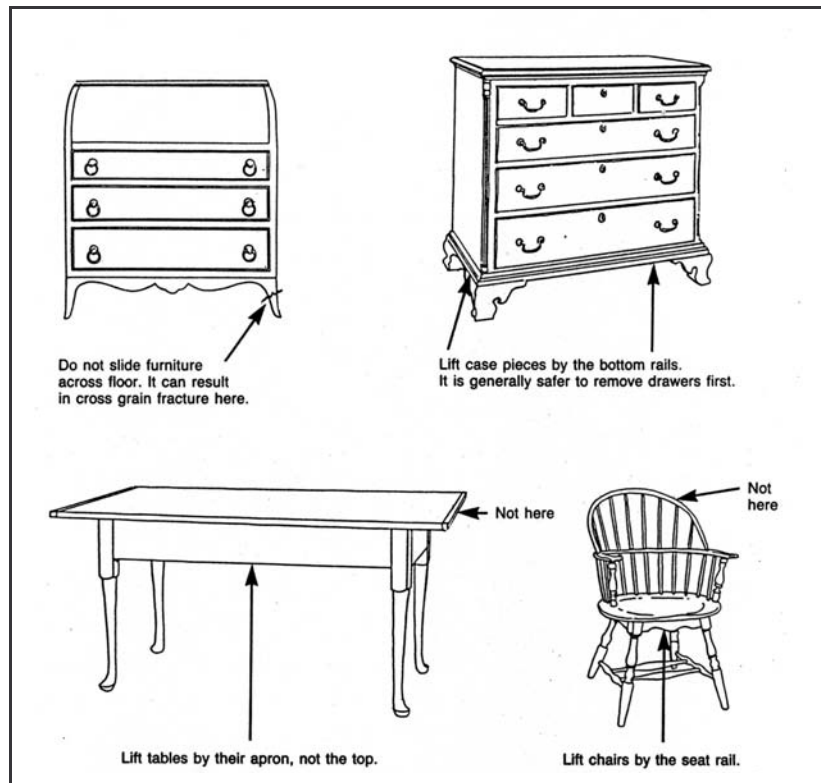

Figure N.7. Proper Techniques for Moving Furniture

3. *What should I do if a part of the wooden piece becomes loose or falls off?*

If small parts become detached because of glue failure, structural failure, or accidents during moving or cleaning, place them in a closable polyethylene bag with a label that documents the date, location from which the piece came, and the catalog number of the object. Keep the bag with the object, if possible, and contact a conservator.

If there is an urgent need to repair the piece, consult the regional/SO curator and seek permission to use a *reversible* glue (for example, hide glue) to reattach the part temporarily. **Do not tack the loose part back into place.**

If more than one piece becomes detached, it usually indicates a problem with either the environment or the housekeeping procedures. The object may be too unstable for exhibit. Seek conservation treatment as soon as possible.

4. *Is there a special technique for removing mold from wooden objects?*

Because mold growth is the result of environmental factors, your first step is to improve the environment.

- Lower the relative humidity level and increase the air circulation.
- Isolate the object from the rest of the collection and place it where it will receive more light.

- Use a HEPA vacuum to remove the mildew from the object and discard the bag, or brush it off, capturing the spores on a drop cloth. A dust mask or respirator may be necessary (see *Conserve O Gram* 2/13, An Introduction to Respirator Use in Collections Management). Dispose of the cloth in a plastic bag.
- Wipe the remaining mold from the object with a solvent-dampened cloth. Use a 50% mixture of alcohol and water on all but shellaced surfaces. Use mineral spirits to clean a shellac finish. Dispose of the cloth.

5. *How can I determine if a wooden object has an active beetle infestation and what should I do about it?*

Evidence of active wood boring beetles, the most common museum insects to attack wooden objects, is easy to spot.

- Examine the surfaces of the piece carefully for *flight holes*—the holes made by these insects as they exit. If there are “bright holes” with sharp edges, the infestation is probably current.
- Look for *frass*, a light-colored powder produced by the larva as it eats the cellulose. It may be found on the floor nearby or on the lower horizontal members of wooden objects.
- Check the windowsills for beetle carcasses during the spring.
- Listen carefully. Some species of wood boring beetles can actually be heard as they chew.

If you suspect an active infestation, isolate the object immediately. Place it on a dark paper or other surface, wrap it with polyethylene sheeting, and monitor it carefully for new frass accumulations. Be careful not to jar the piece, since movement may dislodge older deposits of frass.

Refer to Chapter 5: Biological Infestations, for guidance if you determine that beetles are currently at work.

H. Conservation Treatment

The preservation of wooden furniture and other wooden objects is the responsibility of both curator and conservator. The curator must know how far to go with hands-on housekeeping and when to call the conservator for advice or treatment.

1. *How do I assess the stability of a wooden object?*

Most furniture and other wooden objects in museum collections show evidence of much use and at least some damage. You must be able to determine whether or not that damage makes the object unstable.

An object should be considered unstable when further deterioration is likely to result if the condition is not corrected.

- ***Examine the object carefully for structural stability.*** Look for:
 - glue failure

- mechanical joint failure
- missing and loose elements
- cracks and splits
- fungal or pest activity

Loose joints usually indicate environmental problems that have caused the glue to dissolve or become brittle and fail. Not only is conservation treatment needed to stabilize objects with loose joints, but also the environment must be corrected to prevent the problem from recurring.

Missing parts *may* cause structural instability. A lost finial will not; a lost leg will. If a crack or split occurs in a structural member that must support the weight of the object, conservation treatment is needed. If movement is possible on either side of the split, the object should be treated.

Make sure you can distinguish between decay fungi and mold and mildew. Decay fungi consume cellulose and lignin and will eventually cause severe deterioration. Mold and mildew, on the other hand, disfigure the surface of the wood, but do not cause instability. Decay fungi can be detected by the presence of cracks along and across the grain of the wood, a “dead” sound when tapped, loss of weight, a friable surface, and its characteristic odor. If the decay has not progressed too far, the wood can be consolidated during conservation treatment and a degree of structural stability restored.

Like decay fungi, insects can also cause severe damage to wooden objects. The presence of numerous exit holes on the surface of an object indicates the need for a thorough structural examination. See Section H.4 above.

- ***Examine the finish carefully.*** crazing may or may not require conservation treatment. If the finish is still tightly bonded to the wood surface, it is probably in fairly stable condition. If, however, the islands of finish are loose or are beginning to discolor along the edges, treatment is recommended.
- ***Examine the hardware.*** Look for active corrosion. Dull, oxidized hardware is not necessarily unstable, but active green corrosion on brass or copper hardware should be corrected by conservation treatment. On ferrous hardware, a coating or red or red-orange rust also indicates active corrosion. If corrosion is not stopped, it will deteriorate the metal and may stain the underlying wood.

2. *How should I document the condition of furniture and wooden objects?*

Periodic documentation should be both written and visual. Measured drawings, sketches, and photographs are very useful when they accompany written descriptions.

- Note the occurrence of obvious damage, such as loss of veneer or scratches from cleaning equipment.

- Note deterioration that takes place over a longer period of time, for example, progressive crazing or fading of finishes. Take photographs and date them for comparison.
- Record the length and width of any split you might see. If it is larger on the next inspection, call a conservator for treatment.
- Compare your documentation of condition with the records from environmental monitoring. Seasonal variations in relative humidity may be responsible for the deterioration.

3. *What will a conservator do in the course of treating wooden objects and furniture?*

The conservator's treatment will be determined by the condition and intended use of the object. Typically a conservator will follow these steps:

- ***Examine the object thoroughly*** with the aid of microscopes and specialized photographic techniques to:
 - determine the stability of the structure and the finish
 - determine the causes of deterioration
 - look for evidence of insect and fungal decay
 - identify the type of wood, finish, and adhesive and joinery techniques
- ***Clean the object carefully*** by mechanical and chemical means to:
 - remove foreign soil buildup
 - remove stains and paint deposits
 - remove unwanted (post-period) surface coatings

The conservator preserves important signs of use.

- ***Make structural repairs*** by restoring structural integrity, but not necessarily appearance.

Repairs are reversible so that they can be removed if necessary.

- ***Replicate missing elements*** when desirable with in-kind materials and techniques or modern ones.

The decision to replace missing elements is made jointly by the conservator and the curator. It will depend, in part, on the object's significance and whether or not the size, shape, and design of the missing element are known. Replacements should be:

- documented in writing with accompanying photographs

- labeled with maker and date
- removable
- unobtrusive to the museum visitor, but discernable to the curator
- added with a minimum of damage to the object
- reasonable in cost
- **Consolidate damaged fibers** when the wood has been damaged by fungal activity, insect attack, or chemical action. Consolidants can be made from a number of natural or synthetic resins and a variety of solvents. The process, however, results in a visual change to the wood surface and is never completely reversible. Therefore, the decision to use consolidants should be carefully weighed.
- **Preserve the existing finish** or replace it if necessary. If the existing finish is original, or at least appropriate, and salvagable, preservation is the preferred course. Preservation may involve:
 - cleaning and waxing, if the finish is stable
 - partially dissolving the finish to lay it down if it is lifting and unstable
 - amalgamation of crazed surfaces
 - filling in areas of stain loss with a reversible finish

Refinishing is preferred if the existing finish is either inappropriate or almost completely worn away. Conservators will use the least harmful means of finish removal and a new finish that is resoluble. A small area is usually left intact to document the finish history of the object. The curator and the conservator should carefully consider the decision to refinish.

- **Apply a surface barrier** to protect against moisture, dust, light, and staining. Wax is generally the choice for finished wood surfaces. In some instances, a sheet of acrylic may be used to protect wood surfaces from marring or abrasion.

I. Emergency Procedures for Wooden Objects

1. *What is the most common type of emergency?*

Most emergencies that affect museum objects involve water. Refer to Chapter 10 for guidance on emergency planning. See Chapter 8, *Conserve O Gram 7/7*, Emergency Treatment for Water-Soaked Furniture and Wooden Objects, and *Conserve O Gram 21/6*, Salvage at a Glance Part III: Object Collections, for emergency treatments for wood objects. You will probably need to contact a conservator to take care of the preservation problems created by any disaster.

2. *What preservation problems will I encounter during a flood?*

Water damage usually affects the finish and causes wood to swell. If there is standing water on the floor for a period of time, the water and any salts that may be dissolved in it will be carried up through the end grain of the feet and legs of furniture creating “tide” lines as the salt effloresces. Floods and water-damaged ceilings may deposit mud, plaster, or gypsum on furniture surfaces. The high relative humidity levels often result in mold growth. Upholstery fabrics will stain and probably shrink. Hardware will rust.

Moving furniture after a flood subjects it to even more potential damage. Move it only if necessary. Your focus should be on removing the water instead.

3. *What should I do in the event of a flood?*

Take action immediately:

- Remove all water on and around the object as quickly as possible. Lower the relative humidity level slowly to acceptable levels.

Dry out wet wood objects slowly.

It may be necessary to cover affected objects with a polyethylene tent so they will not dry out too quickly.

- Remove drawers and open doors to dry all surfaces evenly. If drawers and doors stick because of swelling, **do not** force them open.
- Raise all objects off the floor so that the water will not migrate up the feet and legs.
- Use fans to improve ventilation and therefore decrease the likelihood of mold, but **do not** aim the fans directly at the furniture.
- Remove ferrous hardware to avoid stains, especially on woods with high acid levels like oak. Tag all hardware, furniture elements, and loose pieces as you remove them.
- Remove the outer fabric, padding, and support from very wet upholstered furniture. Saturated fabric left in place may split as it dries. The padding can be dried relatively quickly without damage. Feather cushions can be dried in a clothes drier at a low temperature.
- Gently sponge any mud or plaster from stable wood surfaces with clean, cool water. Rinse the sponge often. Gritty sponges and dry cloths will scratch the wood. Wait for a conservator’s assistance to remove mud and plaster from fragile and unstable finished surfaces, such as gold leaf.

J. Selected Bibliography

- Appelbaum, Barbara. *Guide to Environmental Protection of Collections*. Madison, Conn.: Sound View Press, 1991.
- Barclay, Robert, R.L. Eames, and Andrew Todd. *Technical Bulletin 8: The Care of Wooden Objects*. Ottawa, Canada: Canadian Conservation Institute (CCI), 1982.
- Butler, Joseph. *Field Guide to American Antique Furniture*. New York: Roundtable Press, 1985.
- Calinescu, Irena, Catherine McLean, and Jean Neeman. "Low-interventive Upholstery Conservation at LACMA—A Crash Course." *WAAC Newsletter* 18, no. 3 (September 1996): <<http://palimpsest.Stanford.edu/waac/wn/wn18/wn18-3/wn18-306.html>>
- Carlisle, Alexander M. "Guidelines for the Care of Furniture and Wooden Objects." Williamstown Art Conservation Center, Collections Care Supplement. Available online at the Regional Alliance for Preservation Website <<http://rap-arcc.org/wmfurn.htm>>.
- Consadine, Brian. "Furniture." In *Caring for your Collections*. New York: Harry N. Abrams, 1992.
- Gilroy, David, and Ian Godfrey, eds. *Conservation and Care of Collections*. Perth, Australia: Western Australian Museum, 1998.
- Henry Ford Museum & Greenfield Village. "The Care and Preservation of Furniture and Wooden Objects." In *Caring for Your Artifacts*. Available online at <<http://www.hfmgv.org/research/cis/furniture.html>>.
- Hoadley, R. Bruce. *Understanding Wood: A Craftsman's Guide to Wood Technology*. Newtown, Conn.: Taunton Press, 2000.
- Ketchum, William C., Jr. *Chests, Cupboards, Desks, and Other Pieces*. New York: Knopf, 1982.
- Levitan, Al. "Dusting Wooden Objects." *Conserve O Gram* 7/5. Washington, D.C.: National Park Service, 1993.
- McGiffin, Robert F., Jr. *Furniture Care and Conservation*. Rev. 3d. ed. Nashville: American Association for State and Local History, 1992.
- Merrit, Jane. "Mold and Mildew: Prevention of Microorganism Growth in Museum Collections." *Conserve O Gram* 3/4. Washington, D.C.: National Park Service, 1993.
- Penn, T.Z. "Decorative and Protective Finishes 1750-1850." *Association of Preservation Technology Bulletin* Vol. XVI, no. 1 (1984) 3-45.
- Schwartz, Marvin D. *Chairs, Tables, Sofas and Beds*. New York: Knopf, 1982.
- Sandwith, Hermoine, and Sheila Stainton. "Chapter 6: Furniture." In *The National Trust Manual of Housekeeping*, 80-93. London: Penguin Books Ltd., 1984 (Rev. 1993).
- Smithsonian Center for Materials Research and Education. *Furniture and Wooden Objects Guidelines*. Available online at <<http://www.si.edu/scmre/glwood.html>>.
- U.S. Department of Agriculture. "Wood Handbook: Wood as an Engineering Material." *U.S. Forest Service Handbook* No. 72. Washington, D.C.: U.S. Government Printing Office, 1974.
- Williams, Marc A. "Furniture and Wooden Object Preservation and Care." Fremont, N.H.: American Conservation Consortium, Ltd., 1996. Available at <<http://home.netcom.com/~artcons/care.html>>.

Appendix O: Curatorial Care of Metal Objects

	<u>Page</u>
A. Overview	O:1
What information will I find in this appendix?	O:1
Why is it important to practice preventive conservation with metal objects?	O:1
How do I learn about preventive conservation?	O:1
Where can I find the latest information on care of metal objects?	O:1
B. The Nature of Metals and Metal Objects	O:2
What are metals?	O:2
What are some of the metals found in park collections?	O:2
What is an alloy?	O:2
What are surface treatments of metals?	O:2
Is it important to identify different metals?	O:2
How do I identify different metals?	O:2
What is corrosion?	O:4
Is all metal corrosion harmful?	O:4
How can I identify active corrosion?	O:4
What are the characteristics of corrosion for different metals?	O:4
C. Factors that Contribute to Metal Object Deterioration	O:5
What agents of deterioration affect metal objects?	O:5
What is the best relative humidity and temperature for my metal objects?	O:6
Should I be concerned about atmospheric pollution?	O:6
Does cleaning contribute to deterioration?	O:6
D. Proper Handling and Storage of Metal Objects	O:6
What do I need to know about handling metal objects?	O:6
Can I use a jeweler's cloth after handling uncoated metal objects?	O:7
How should I store my metal objects?	O:7
What kind of shelving and cabinetry should I use?	O:7
What additional protection do metals need in storage?	O:8
E. Exhibiting Metal Objects	O:8
What do I need to consider when planning an exhibit?	O:8
Are there any particular concerns for exhibiting metal objects?	O:8
Are there any specific situations that should be avoided when exhibiting metal objects?	O:8
What should I know about cleaning metal objects?	O:9
F. Conservation Treatment	O:9
Why should I contact a conservator?	O:9
What might a conservator be able to tell me about my metal object upon examination?	O:9
Should protective coatings be applied to metals?	O:9
Who should clean and apply coatings to metal objects?	O:9
What are some common metal coatings?	O:10
G. Emergency Procedures for Metal Objects	O:11
H. Special Considerations for Archeological Metal Objects	O:12
I. Glossary	O:12
J. Web Resources	O:15

K. Selected ReferencesO:15

List of Figures

Figure O.1. Identification of MetalsO:3
Figure O.2. Identifying Active CorrosionO:5

APPENDIX O: CURATORIAL CARE OF METAL OBJECTS

A. Overview

1. *What information will I find in this appendix?*

This appendix discusses historic objects made primarily of metals and their long-term care and preservation. The main topics covered in this appendix are:

 - the nature of metals
 - agents of deterioration
 - handling, storage, and exhibit of metal objects
 - working with a conservator when treatment is needed
 - specific emergency procedures for metal objects

Note: This appendix does not cover metals recovered from archeological sites. Care of archeological objects is discussed in Appendix I.
2. *Why is it important to practice preventive conservation with metal objects?*

Metals are very reactive and many factors contribute to their deterioration, but a metal object's rate of deterioration can be slowed significantly with proper preventive care. Practicing preventive conservation will also reduce the need for costly and time-consuming conservation treatment.
3. *How do I learn about preventive conservation?*

Read about the agents of deterioration that affect metal objects so that you can create a preventive conservation plan. See Chapter 3: Preservation: Getting Started, and Chapter 4: Museum Collections Environment, for discussions of the agents of deterioration. Refer to the *Museum Handbook* Part III, Chapter 7: Using Museum Collections in Exhibits, for additional information.
4. *Where can I find the latest information on care of metal objects?*

There are a variety of resources for up-to-date information on metal objects including:

 - NPS *Conserve O Gram* series
 - World Wide Web sources listed in Section J
 - Selected references in Section K
 - Regional/SO curator or collections manager of a large metals collection
 - Objects conservators

B. The Nature of Metals and Metal Objects

1. *What are metals?*

Metallic elements compose the largest proportion of materials that make up our planet. Metallic ores are refined by the application of energy to produce metals. The physical properties of metal include:

- luster
- hardness
- strength
- malleability
- temperature sensitivity

Different metals exhibit different physical properties. Historically, these various properties have been exploited in the construction and fabrication of metal objects and structures. Metals are frequently selected for applications in architecture, decorative arts, fine arts, and functional objects.

2. *What are some of the metals found in park collections?*

Among the metals found in museum objects are gold, silver, copper, tin, iron, lead, zinc, nickel, and aluminum. Metals are frequently combined in order to modify their properties or to obtain a metal that is most suitable to a given application. The process of combining two or more metals is termed *alloying*.

3. *What is an alloy?*

An alloy is created by melting one metal and then adding another metal to it. An alloy is a solid solution since the metal elements remain distinct, one suspended in the other. Examples of common alloys are *brass* (a mixture of copper and zinc), *bronze* (a mixture of copper and tin and other metals), and *sterling silver* (a mixture of silver and copper). By varying the proportions of copper and zinc in brass alloys it is possible to obtain a range of brass alloys with differing properties including color, strength, corrosion resistance, or working properties.

4. *What are surface treatments of metals?*

Surface treatment can be an important characteristic of a metal object. Frequently metals are finished to enhance the appearance of the object, to improve the functional performance (for example, corrosion resistance), or a combination of both. Surface treatments include polishing, plating, patination, coatings, heat treatments, and chemical coloring treatments.

5. *Is it important to identify different metals?*

Yes. Proper identification of metals is important to housekeeping procedures, accurate interpretive program information, storage and exhibit techniques, climate control, handling methods, and the conservation treatment process.

6. *How do I identify different metals?*

You can identify metals by color, weight, function, magnetic properties, or hardness. If you are unsure of the metal object's identification, consult a conservator or your regional/SO curator. To identify a metal object properly, you need to have a basic knowledge of the properties of metals and have a few tools and supplies. If you can't identify a metal, it is better to use more generic terms to describe it. For example, describe a metal as a

white metal instead of running the risk of misidentifying it as pewter, silver, or nickel.

DO NOT use chemical spot tests or spark tests to identify metals. This can damage or destroy the object.

Metal	Color	Other Identifying Characteristics	Primary Alloys and Uses
Iron & Iron Alloys	Grey/silver, blue-black and red-brown color.	Some but not all iron alloys are magnetic.	Cast Iron (iron & carbon, 2% to 4%). Kettles, door hardware, fire-backs, stoves. Wrought Iron (pure iron & carbon, not more than .035%). Railings, nails, wagon hardware. Steel (iron & carbon, 0.15% to 2 %). Knives, tools, structural materials.
Copper & Copper Alloys	Yellow to rich browns. Surface may be patinated and vary in color from red, brown, black and blue to shades of green.		Brass (copper & zinc). Lighting devices, jewelry, scientific instruments, marine fixtures, cookware. Bronze (copper & tin). Bells, cannons, bearings. Nickel Silver (copper & nickel & zinc). Household decorative objects.
Lead	Pure lead and lead alloys where lead predominates, dull metallic blue in color.	Very heavy & very malleable.	Pipes, pump wells in ships, toys, roofs, bullets, and solder.
Silver & Silver alloys	White metallic appearance.	Sterling silver is usually hallmarked.	Numerous silver-copper alloys such as Sterling, coin silver, jewelry, and tableware.
Nickel	Gray to white appearance.	Metal is slightly magnetic.	Nickel is often used in its pure form as a plate for tableware, kitchenware, and decorative ornaments.
Tin & Tin Alloys	Dull gray.		Pewter (tin & antimony & copper). Kitchenware and plating for tin cans and toys

Figure O.1. Identification of Metals

7. *What is corrosion?*

Corrosion is the chemical or electrochemical reaction between a metal and its environment that produces deterioration of the material and its properties. It is the most commonly occurring problem of metal objects. Corrosion can take many forms depending on the metal(s) that compose the object, the manner in which they are fabricated, or the environment in which they are exhibited or stored. At times, the corrosion source may be from fabrication in the case of stress corrosion cracking in thin turned brass objects or contamination from solder flux in joined metals. In other instances, the conditions responsible for corrosion may be an integral part of the environment, such as a seacoast or polluted urban air.

8. *Is all metal corrosion harmful?*

No. The presence of a corrosion product on a metal object does not necessarily indicate active corrosion. Corrosion, tarnish, and patination are all examples of metal compounds, some of which are unintentional and considered disfiguring, while others are deliberately created for an aesthetic effect. While some forms of corrosion are more protective and stable than others, almost all are subject to failure at some critical relative humidity level or in the presence of certain pollutants. When metals are cleaned the surface can oxidize and be chemically stable.

9. *How can I identify active corrosion?*

Active corrosion can be identified visually by the following characteristics:

- color (wet or dry in appearance)
- powdery or flaky formations on the surface of the object and similar deposits around the base of the object
- loosely adhering formations, frequently appearing in patches on the surface as opposed to uniform, dense, well-adhered deposits
- continuing change or growth

10. *What are the characteristics of corrosion for different metals?*

Surface characteristics and colors of metals vary by alloy. Corrosion products also vary in color, depending on the alloy and cause of corrosion.

See Figure O.2 for additional information.

CAUTION! Lead acetate corrosion is a severe poison that can be fatal if swallowed, inhaled, or absorbed through the skin. If you see white, crystalline corrosion products on lead objects in your collection, assume that they are lead acetate and handle accordingly. Material Safety Data Sheets uniformly state that protective equipment for lead acetate should include goggles, lab coat, vent hood, and rubber or plastic gloves. This type of corrosion is often seen on lead bullets and toy soldiers.

Metal	Active Corrosion	Stable Surfaces	Causes of Corrosion
Iron & Steel	Orange to reddish-brown. Wet or glossy appearance. A surface that is scaling, flaking or pitting.	Compact blue-black and red-brown color.	High relative humidity, surface moisture.
Lead	Loose white powder in tiny spots or overall.	Smooth gray surface.	Weak organic acid vapors, from sources such as wood, cardboard, and vinegar.
Copper & Copper Alloys	Corrosion forms in small spots overall. Powdery green, blue, and white corrosion products that are generally over the entire surface.	Wide variety of colors: solid blue, green, red, brown, or black. Surfaces are smooth and tightly adherent.	High relative humidity, surface moisture, air pollution, salts from inappropriate cleaning and handling.
Silver and Silver Alloys	Slight gray dullness through blue/purple that deepens to brown/black as corrosion becomes thicker.	Smooth white metallic. A blue/purple surface can be stable if it occurs overall and the object is removed from the source of corrosion.	High humidity, sulfur compounds, etching from fingerprints, organic vapors.
Nickel	Nickel corrosion is reddish brown and is similar in appearance to rust. Green copper corrosion products indicate preferential corrosion from a copper alloy.	Smooth gray appearance.	High humidity and sulfur compounds.
Tin & Tin Alloys	White gray, dark gray to black. Nodules of white to gray corrosion that form under the surface layer in nodules that erupt through the surface exposing a light gray or white corrosion product.	Smooth gray surfaces.	High relative humidity, atmospheric pollutants, low temperatures.

Figure O.2. Identifying Active Corrosion

C. Factors That Contribute to Metal Object Deterioration

1. *What agents of deterioration affect metal objects?*

The primary causes of metal object deterioration in the museum or historic furnished house are:

- relative humidity
- temperature extremes
- atmospheric pollutants

- improper care and handling

2. *What is the best relative humidity and temperature for my metal objects?*

Keep relative humidity in metal collections as low as possible. Steels will not rust and brass will not tarnish below 15% RH. This is not a practical solution for metal objects in the historic furnished structure, but it may be for objects in storage cabinets or exhibit cases. Ambient temperatures between 60° and 75°F are appropriate for most metals. To inhibit active corrosion in salt air environments, metals should be housed in spaces with relative humidity levels no greater than 35%.

It is generally a good idea to avoid low temperatures for most metal objects. Low temperatures usually result in higher levels of relative humidity and the possibility of condensation on metal surfaces.

3. *Should I be concerned about atmospheric pollution?*

Yes, many forms of air pollution are corrosive. Polluted urban air and coastal environments are among the more severe areas. Dirt and dust may contain chemical compounds that will react with metals or trap moisture close to the metal surface. Sulfur and sulfur compounds are probably the strongest tarnishing agents. Sulfur is present in the air from burning of fossil fuels and is generated from products such as foam rubber, carpet padding, paints, wool, and felt.

4. *Does cleaning contribute to deterioration?*

Cleaning and polishing remove original metal. Over-cleaning often results from a desire to have metals bright and shiny, especially brass and silver objects on display in a historic furnished structure. Intense treatment often results in the loss of information from the object. In addition, metal cleaners may leave harmful chemical residues that can generate further corrosion.

D. Proper Handling and Storage of Metal Objects

1. *What do I need to know about handling metal objects?*

All of the general rules for safe handling of three dimensional museum objects apply to metal objects. Refer to Chapter 6: Handling, Packing, and Shipping, for general guidance on handling museum objects. Two special concerns for metals are the weight of the object and skin contact with bare metal surfaces.

- Metal objects can be heavy. The inadvertent placement of a heavy metal object on another object or on a period piece of furniture may result in dents, scratches, or staining.
- Transport heavy metal objects on carts or dollies.
- Most metal objects should not be handled with bare hands. Salts and oils from your skin can etch metals and may even cause permanent damage.
- Always wear clean cotton, latex, or synthetic rubber gloves when handling metal objects. Avoid cotton gloves if the decorative surface is friable. Avoid cotton gloves with polyvinyl chloride (PVC) nubs when handling metal objects. PVC residues from the nubs may cause oxidation or tarnish. Synthetic rubber gloves are not recommended for handling silver or copper alloys because some brands contain high proportions of sulfur and chlorides.

See caution in B10 on handling corroded lead objects

2. *Can I use a jeweler's cloth after handling uncoated metal objects?* Yes. A jeweler's cloth can be used to wipe or buff away fingerprints on uncoated gold, silver, copper alloys, and highly polished steels, if an uncoated metal object is inadvertently touched. Select cloths that contain no abrasive, and rely instead, on the stiffness of the weave for their polishing effect. Any clean, soft cloth may be used to buff an object after handling.
3. *How should I store my metal objects?* Follow these guidelines:
- To the extent possible, house metal objects indoors to reduce exposure to rain and temperature extremes.
 - If possible, keep all metal objects together. Further isolation can be made according to metal type, object size, and object type.
 - Never store metal objects directly on the floor or in close proximity to exterior walls. Avoid storing metal objects in attics and basements.
 - Metals are normally immune to biological attack; however, the droppings of pigeons, mice, and even insects will cause pitting and corroding of a metal object's surface.
 - Keep metals away from hygroscopic materials such as paper, textiles, and wood.
4. *What kind of shelving and cabinetry should I use?* Follow these guidelines:
- Steel shelving is preferred over wood shelving because it is stronger and it does not emit harmful vapors. Line shelves with an inert, nonabsorbent material such as expanded polyethylene.
 - The standard museum specimen cabinet provides excellent storage for metal objects. Depending on degree of seal, some of the newer museum storage cabinets can be used to create microenvironments using silica gel to control RH.
 - For heavy metal objects such as cannon tubes and sculpture, polyethylene plastic pallets are available to prevent contact with the ground or floor.
 - Loosely drape clear polyethylene over shelves to protect metal objects from water leaks and dust.

5. *What additional protection do metals need in storage?*

You may need to use microclimates to protect some collections. Consult with a conservator to determine which collections are most vulnerable. A conservator may recommend:

- **Activated charcoal paper:** Activated charcoal absorbs air pollutants.
- **Silica gel:** Silica gel can be used to reduce and to buffer the relative humidity of an enclosed space. The bags must be monitored and reconditioned as necessary. See *COG 1/8*, “Using Silica Gel in Microenvironments.”
- **Vapor phase inhibitors:** These materials release a vapor that inhibits corrosion. **Note:** Many vapor phase inhibitors are toxic.
- **Clear plastic boxes & bags:** Various plastic boxes and bags can be used to create microenvironments and allow conditions to be monitored inside.

E. Exhibiting Metal Objects

1. *What do I need to consider when planning an exhibit?*

Conditions within the exhibit space are usually more subject to change than those in the storage space. This is especially true for historic furnished structures. The goal is to create an exhibit environment that is just as safe and controlled as possible. All of the general rules for safe display of three-dimensional objects apply to metal objects. Refer to the *Museum Handbook*, Part III, Chapter 7: Using Collections in Exhibits, and NPS *Exhibit Conservation Guidelines*, available from the Harpers Ferry Center.

2. *Are there any particular concerns for exhibiting metal objects?*

Consider the following:

- Cast and wrought iron objects are often exhibited in hearths, on mantles, or hung on the fireplace. Rainwater may enter through the flue, and brick and mortar will trap the moisture. In addition, chimneys are usually cold. All of these conditions promote condensation and corrosion.
- During seasonal transition periods, fluctuations of temperature and relative humidity can promote condensation and corrosion on metal objects.
- Frequent cleaning of exhibit areas may add moisture and potentially harmful vapors to the environment.
- Ensure that exhibit mounts are padded to prevent scratching

3. *Are there any specific situations that should be avoided when exhibiting metal objects?*

Follow these guidelines:

- Avoid leaving doors and windows open as gaseous and particulate pollutants can enter the exhibit area causing corrosion. This is a particular concern in urban areas.

- Avoid lighting fixtures such as fluorescent light ballasts or transformers that may generate ozone. Ozone will cause corrosion on metal surfaces.
- Avoid using hardwoods, such as oak, in exhibit cases because they can emit acidic vapors that corrode lead and silver.
- Avoid the use of adhesives, paints, woods, and textiles in exhibition cases and exhibition spaces unless they have been tested for off-gassing. See Chapter 4: Museum Collections Environment, for information on gaseous air pollutants and safe construction materials for exhibitions.

4. *What should I know about cleaning metal objects?*

Be aware that many proprietary cleaning products contain ammonia, weak acids or bases, solvents, waxes, and fats that may have an adverse effect on metal objects. Refer to Chapter 13: Museum Housekeeping, for additional information.

F. Conservation Treatment

1. *Why should I contact a conservator?*

All interventive treatment must be undertaken by a conservator trained to examine, analyze, stabilize, and treat objects. Conservators are trained in the treatment of specific materials. See Chapter 3: Preservation: Getting Started, and Chapter 8: Conservation Treatment, for information on choosing and contracting with a conservator. Be sure you check references and question the experience and background of any conservator you choose. Discuss any recommended treatments and be sure you understand what is planned and why it is necessary.

Only experienced conservators who agree to follow the AIC Code of Ethics and Guidelines for Practice should be allowed to treat NPS museum objects.

2. *What might a conservator be able to tell me about my metal object upon examination?*

When conservators examine metal objects they can tell you a number of things, including:

- the type of metal
- the type and source of any corrosion product
- the range of possible conservation treatments

3. *Should protective coatings be applied to metals?*

Protective coatings are often applied to metal objects to prevent or reduce the possibility of corrosion from high humidity, frequent handling, atmospheric pollution, and to reduce the need for aggressive cleaning such as polishing.

4. *Who should clean and apply coatings to metal objects?*

All metal objects are best left **untreated** until an objects conservator has had an opportunity to examine them. Cleaning involves the risk of over-cleaning, exposure to hazardous solvents and chemicals, and the consequence of higher corrosion rates on freshly exposed metal surfaces.

A conservator should specify the most appropriate coating for an object and determine who best can apply the coating. With appropriate training by a conservator, collections management staff can be trained to coat metals with wax. The scope of treatment may be expanded to include other barrier coatings or corrosion inhibitors. This type of treatment is especially good for objects stored or exhibited outdoors.

5. *What are some common metal coatings?*

The most common metal coatings are:

- waxes
- lacquers
- corrosion inhibitors

Some preventive conservation measures for metal objects require hands-on methods. Preventive measures should mitigate frequent handling of the object, be easy to apply and to remove, and be safe for both the object and the person applying the material. Wax is an example of such a material.

Before applying any surface coating it is very important to properly identify the metal surface. Ask an objects conservator to conduct a Collection Condition Survey that includes current condition and provides information about routine maintenance.

- **Waxes.** Waxes are easy to apply, relatively safe and easy to remove, and provide reasonably long-term protection to the metal surface.
 - Waxes may be natural or synthetic.
 - The metal object should be polished, washed, thoroughly dried, and buffed before waxing.
 - Most waxes suitable for use in an exhibit space can be applied at room temperature.
 - Be aware that waxes will collect dust, are a food source for some molds and fungi, and may blanch or turn white.
 - Avoid natural waxes such as bees wax, which may be acidic. Use instead manufactured microcrystalline waxes as specified by a conservator.
- **Lacquers.** Lacquers, like waxes, can be natural or synthetic. Generally, synthetic lacquers and waxes are considered to be more stable than those derived from natural products. The objections to protective lacquer coatings are not well founded. A common objection is that lacquers make a metal object look “plastic.” Matting agents are available if necessary. Considering the difference in wear caused by frequent polishing or less frequent waxing, the lacquer finish provides the toughest and the longest lasting protection.
 - Lacquers are more difficult to apply and to remove than waxes.

- Lacquers are harder than waxes and will usually last for five to ten years before reapplication is necessary.
- Certain solvents used in lacquers, such as toluene or xylene, pose health hazards. An objects conservator should be consulted and asked to apply the lacquer coating or to train the staff in the use of these materials.
- Lacquers when properly applied will not adversely affect the appearance of an object.
- **Corrosion Inhibitors.** Corrosion inhibitors react with the surface of a metal object to prevent corrosion. Some corrosion inhibitors are available commercially and others can be obtained from chemical supply houses. They also may be incorporated into waxes and resins. This provides an additional degree of protection should the wax or resin be scratched. Most corrosion inhibitors are metal specific.

Keep in mind that corrosion inhibitors are not fool proof. Any metal treated with an inhibitor is still subject to corrosion at or above the critical relative humidity for that metal. For that reason, coatings, inhibitors and environmental quality should be considered an integrated system requiring ongoing maintenance.

CAUTION! Many corrosion inhibitors are toxic.

G. Emergency Procedures For Metal Objects

Metals are very reactive materials. In an emergency situation, corrosion can cause irreversible damage to inorganic materials, complicating their salvage. If the metal object has survived a fire and the deluge of water, a flood, or a storm, the first course of action is to isolate it from other materials.

Be sure to:

- Implement security precautions for precious metals and objects of intrinsic value such as metal sculpture.
- Provide a secure dry storage area for all metal objects.
- Have an objects conservator prepare a Collection Condition Survey that documents each object's condition, recommends needed conservation treatment, and outlines remedial preventive conservation procedures.
- Rinse, sponge, and blot metal objects. Air dry.
- If the object has an applied finish, do not clean it. Air dry. Keep flaking surfaces horizontal.

Refer to Chapter 10: Emergency Planning, for information about planning for emergencies and minimizing damage.

In an emergency situation, do not attempt to perform interventive treatments on metal objects.

H. Special Considerations for Archeological Metal Objects

Considerations for the care and conservation of archeological metals are considerably different than for historic metals. Care of archeological metals is discussed in Appendix I.

I. Glossary

Abrasion: the wearing, grinding, or rubbing away of surface material by friction, usually through the action of particulate matter (e.g., sand) or as a result of rubbing by people, animals, or plants

Accretion: the accumulation of extraneous materials on the surface of an artifact, sculpture, or monument. It may include core materials, deposition of insoluble salts, or even the heavy accumulation of dirt, grime, pollutants, or bird droppings.

Acid deposition: the deposition of acidic constituents onto a surface. This occurs not only by precipitation, but also by the deposition of atmospheric particulate matter and the incorporation of soluble gases.

Acid precipitation: rain, snowfall, or atmospheric moisture below pH 7

Alloy: metallic material composed of two or more elements intimately mixed

Amalgam gilding: a process for applying gold to the surface of another metal, usually a copper or silver alloy, by forming a paste of mercury and gold

Annealing: a process of heating and cooling sheet metal, which has become work-hardened by hammering, spinning, or stamping, in order to relieve stress and to return the metal to a malleable state

Anode: the positive electrode of an electrolytic cell at which oxidation is the principal reaction. Electrons flow away from the anode. Usually the anode is where corrosion occurs and metal ions enter solution.

Bimetallic corrosion: corrosion resulting from dissimilar metal contact; galvanic corrosion

Brazing: a method of joining nonferrous metals using a nonferrous alloy that melts at a lower temperature than that of the metals to be joined. Brazing is similar to soldering; the distinction being that soldering is accomplished at temperatures below 800°F, and brazing is done above 800°F.

Bronze: an alloy of copper and tin and sometimes other elements

Bronze disease: copper corrosion in which chloride is the primary corrosive agent. It is rare, but may develop on archeological specimens or objects that have been recovered from the sea.

Burnish: a method to smooth rough surfaces of a metal by rubbing a hard stone or highly polished, harder metal over the surface

Casting: an object created by pouring molten metal into a mold

Cathode: the negative electrode of an electrolytic cell. Electrons flow toward the cathode in the external

circuit. Corrosion does not occur at the cathode (see Anode).

Chasing: a metal finishing technique intended to sharpen or add detail on an object. For sculpture, the term is expanded to include all finishing techniques.

Checking: surface cracking in a checkerboard-like pattern often associated with the degradation of a protective coating

Chemical conversion coating: a protective or decorative nonmetallic coating created by treating the metal with an acidic or basic compound. Examples are coatings on iron produced by tannic or phosphoric acid.

Coating: a protective barrier, usually a synthetic resin or a wax, applied to a metal surface

Corrosion: the electrochemical degradation of a metal, due primarily to the loss of electrons and the recombination of metal ions with other electro-negative elements such as oxygen, carbon, sulfur, chloride, and nitrogen

Critical humidity: the relative humidity above which atmospheric corrosion rates of some metals increase sharply

Electrolytic cleaning (electrolytic reduction, electrolysis): a powerful method of cleaning metals used particularly if they are heavily corroded or salt contaminated. An object is wired to a low voltage direct current and is suspended between metal plates in a conductive solution.

Electroplating: the deposition of a metal from a solution of one of its salts onto a metal surface using an electrical current

Electrotyping: a process identical to electroplating. Electrotyping is used to build up thick metallic deposits on the interior of nonmetallic molds. It might be thought of as an electrolytic form of casting.

Embossing: raising a design in relief on a surface

Engraving: a decorative technique in which metal is removed by cutting into the surface with gravers

Etching: the production of patterns on a surface by the use of a corrosive chemical agent

Ferrous metals: composed of iron as the dominant metal

Filigree: decoration by means of thin, twisted wire soldered together into an openwork structure

Finishing: cleaning, polishing, patinating, and coating metal

Flux: a substance applied to metals being welded, soldered, or brazed to improve flow

Forging: shaping metal, usually steel and iron, by hammering while the metal is hot

Galvanic corrosion: accelerated corrosion of a metal because of an electrical contact with a more noble metal

Gild: to overlay with a thin covering of gold

Glass bead peening: dry blasting of a surface with glass microspheres

Graver: a chisel-like tool used for engraving metal surfaces

Inclusions: particles of impurities, such as mold materials, ferrous metal, or slag

Incralac: synthetic resin that contains the copper corrosion inhibitor, benzotriazole

Intergranular corrosion: preferential corrosion at, or adjacent to the grain boundaries of a metal or alloy

Inhibitor: a chemical substance that prevents or reduces metallic corrosion

Lacquer: an organic resin coating. The resin may contain matting agents or corrosion inhibitors. Some historic resins were pigmented.

Lost wax casting: a casting technique that utilizes a wax model or pattern. A refractory mold material is used to cover the wax pattern. The mold is later heated, the wax melts, and molten metal is poured into the resulting hollow.

Machining: shaping of metal with machines such as the lathe, planer, milling machine, drill press, and grinder

Metals: elements or mixtures of elements that possess high electrical conductivity and a lustrous appearance in the solid state

Mold: a form containing a refractory void (mold cavity) into which molten metal is poured during casting

Nonferrous metals: not composed of iron

Passive: the state of a metal surface characterized by low corrosion rates

Patina: a colored layer on the surface of a metal. This term is usually, but not always applied to copper alloys. The layer may be naturally occurring or artificially produced.

Planishing: a forming technique utilizing stakes and highly polished hammers to shape sheet metal

Plating: a thin layer of metal deposited on the surface of another metal

Raising: forming a hollow shape in metal by hammering on the outside surface over a dome headed stake or anvil

Repoussé: a technique whereby hammering from the inside produces raised areas on the outside of a sheet metal object

Rust: a corrosion product consisting of hydrated iron oxide. This term is properly applied only to ferrous alloys.

Sand casting: a casting technique that uses sand or sandstone as the refractory mold material

Sandstone casting: a casting technique that uses sandstone as the refractory mold material

Soldering: the use of alloys that flow at low temperatures to join two or more metal parts having higher melting points

Spinning: a metal forming technique in which sheet metal is rolled over a form on a lathe

Stamping: impressing a design into sheet metal with a metal die

Steel: an alloy of iron and carbon, with a carbon content between 0.15 and 2.0%

Stress-corrosion cracking: a cracking process that requires the simultaneous action of a corrosive agent and

sustained tensile stress

Tarnish: discoloration of a bright metal surface by a thin film of corrosion products

Tinning: covering a metal surface with tin

Tin Pest, Tin Disease: deterioration of tin caused by changes in the crystal structure at low temperatures (below 56°F)

Welding: joining two pieces of metal at a temperature close to their fusion point

J. Web Resources

American Institute for Conservation Disaster Recovery Page: <<http://palimpsest.stanford.edu/aic/disaster/>>.

Conservation OnLine, Resources for Conservation Professionals: <<http://palimpsest.stanford.edu>>.

Conserve O Gram Leaflets: <<http://www.cr.nps.gov/museum/publications/index.htm>>.

K. Selected References

Boyer, Howard E., and Timothy L. Gall, eds. *Metals Handbook, Desk Edition*. Metals Park, Ohio: American Society for Metals, 1985.

Canadian Conservation Institute. *CCI Notes*. Ottawa, Ontario: Canadian Conservation Institute, 9/1, "Recognizing Active Corrosion."
9/3, "The Cleaning, Polishing, and Protective Waxing of Brass and Copper Objects."

Hodges, Henry. *Artifacts*. London: John Baker Publishers, 1964.

Light, John D. "A Field Guide to the Identification of Metal." In *Studies in Material Culture Research*, edited by Karlis Karklins, 3-19. Tucson: Study for Historical Archaeology, 2000.

Mulholland, James A. *A History of Metals in Colonial America*. University, AL: The University of Alabama Press, 1981.

National Association of Corrosion Engineers. *Glossary of Terms*. Houston: National Association of Corrosion Engineers, 1988.

Sandwith, Hermione, and Sheila Stainton, eds. "Metalwork." In *The National Trust Manual of Housekeeping*, 103-115. London: Penguin Books, Ltd. and the National Trust, 1982.

Weisser, Terry Drayman. "Metal Objects." In *Caring for your Collections*, edited by Harriet Whelchel, 108-121. New York: Harry N. Abrams, Inc., 1992.

Appendix P: Curatorial Care of Ceramic, Glass, and Stone Objects

	<u>Page</u>
A. Overview	P:1
B. The Nature of Ceramic Objects	P:1
How are ceramic objects made?	P:1
How are ceramics fired?.....	P:2
What does firing do?	P:3
What surface treatments are used for ceramics?.....	P:4
How are ceramics formed?.....	P:5
What flaws might I find in ceramic objects?.....	P:5
C. The Nature of Glass Objects	P:6
What materials make up the structure of glass objects?	P:6
What are the hot shaping processes?.....	P:7
What cold-working techniques are used to decorate glass?	P:8
What flaws might I find in glass objects?	P:8
D. The Nature of Stone Objects	P:8
What materials make up the structure of stone objects?.....	P:8
How are stone objects formed?	P:9
Will I see different techniques used on archeological stone objects?	P:10
What different tools and techniques are used on contemporary sculpture?.....	P:10
E. Deterioration of Ceramics, Glass, and Stone	P:10
How do ceramics deteriorate?	P:11
How does glass deteriorate?	P:11
How does stone deteriorate indoors?.....	P:11
How does stone deteriorate outdoors?.....	P:12
Should I move stone objects indoors?	P:13
F. Preventive Conservation	P:13
What special handling rules for ceramic and glass objects should I know?	P:13
What special handling rules for stone objects should I know?.....	P:14
What environmental parameters should I use for ceramic, glass, and stone objects?.....	P:14
What light levels should I set for ceramics, glass, and stone?	P:15
How should I store stable ceramic and glass objects?	P:15
Are there special storage concerns for unstable glass and ceramics?.....	P:16
What are the storage requirements for stone objects?.....	P:17
What special preventive conservation concerns should I have for ceramic, glass, and stone objects on exhibit?	P:18
G. Care of Composite Ceramic and Glass Objects	P:19
H. Treatment Issues for Ceramic, Glass and Stone Objects	P:21
What should I consider before cleaning ceramic and glass objects?	P:21
What should I consider before cleaning stone objects?	P:21
How can I tell if an object has been repaired?	P:22
Should old repairs be removed?.....	P:22
What should I discuss with the conservators before losses are filled?.....	P:22
When are objects consolidated?.....	P:22

	<u>Page</u>
I. Packing and Shipping Glass, Ceramic, and Stone Objects	P:23
How should I pack ceramic, glass and stone objects for shipping?	P:23
How will I ship particularly heavy items?	P:23
J. Emergency Procedures for Ceramic, Glass, and Stone Objects	P:24
What special procedures should I follow for ceramic, glass, and stone objects after a disaster? .	P:24
How do I recover from a disaster with ceramic, glass, and stone objects?	P:25
K. Selected Bibliography	P:25
Figures	
P.1. Method of Stabilizing Objects in Storage.....	P:16
P.2. Flush Mount for Hanging Heavy Mirrors.....	P:20
P.3. Technique for Wrapping a Fragile Object.....	P:23
P.4. Layered Foam packing for Fragile Objects.....	P:24

APPENDIX P: CURATORIAL CARE OF CERAMIC, GLASS, AND STONE OBJECTS

A. Overview

This chapter is an overview of three common materials found in many museums:

- *ceramics*
- *glass*
- *stone*

These are all hard, yet brittle and fragile materials that have been used since ancient times. Objects made of ceramic, glass, or stone can be both decorative and practical. They can be as tiny as a bead or as large as an outdoor sculpture, but all these objects share some basic properties in common. To properly care for the ceramic, glass, and stone objects in your collection you need to understand their properties and how they can deteriorate. This appendix will address:

- how ceramic, glass, and stone objects are made
- common deterioration problems
- preventive conservation in caring for these objects
- storage
- basic treatment issues
- specialized procedures for packing and shipping
- basic procedures to limit damage after a disaster

For information on the particular needs of glass plate negatives and transparencies see *Conserve O Gram 14/5, Caring for Photographs: Special Formats*.

B. The Nature of Ceramic Objects

1. *How are ceramic objects made?*

Ceramic objects are made up of a mixture of natural materials that are combined, formed into shape by a variety of processes, and transformed by heat to create a solid, brittle substance not found in nature. Different firing temperatures produce objects with a vast range of hardness and porosity.

Most clay objects are a mixture of materials:

- Clay is a fine-grained mineral--the smallest particles produced by the weathering of certain rocks. Because of the shape and size of the small plate-like clay crystals, bulk clay is plastic when mixed with water. When heated to a high temperature it chemically and physically changes to a hard, brittle material.
- Adding fluxes such as soda, mica, potash, magnesia, or lime lowers the firing temperature of clay. These fluxes may also be found in natural clay deposits.
- Non-plastic additives (temper) are added to clay to reduce shrinkage and cracking during firing and drying. Temper also increases porosity in the finished object.

These basic materials are mixed together by the potter to produce a heterogeneous plastic mass that is then formed into the ceramic object.

2. *How are ceramics fired?*

A kiln is used to fire ceramics to change the physical and chemical structure and fuse it into a rock-like material. Kilns can vary from simple piles of fuel to complex multi-storied structures. However, all kilns work using the same basic principle. Each kiln is designed to:

- house the objects
- control the amount and duration of oxygen and heat
- hold the level of heat surrounding the object

The process of drying and firing is a series of controlled steps. After the object is formed it must be slowly air-dried. Much of the water (up to 25% of prepared clay) evaporates as the object dries. If the air-drying process is not done carefully, you may see shrinkage cracks in the object. After a day or two of drying objects to a "leather-hard" state, ceramics will maintain their shape, but the surface can still be easily worked. Often the potter will do final finishing, smoothing, polishing, and painting at this point. By the time air-drying has finished, most of the free water between the clay particles has evaporated.

Objects may undergo a single firing or multiple firings. Many archeological ceramics are fired a single time at temperatures ranging from 800-1400°C. Potters may apply glazes to an air-dried object so that glaze and body vitrify together in a single firing. This process is known as "through firing." However, most glazed objects undergo multiple firings. First, the potter does a "bisque" firing by heating the object to about 600°C to strengthen the object. The glaze is then applied to the cooled bisqueware. It is then returned to the kiln and fired again, this time to a higher temperature (above 800°C) so that vitrification of the glaze and ceramic occur.

If overglaze decoration, gilding, decals, or enamels are used to decorate the surface, an additional low-temperature (600-900°C) firing may take place.

3. *What does firing do?*

After clay objects are formed, they are heated to high temperatures or "fired." This action causes chemical changes to the clay. After firing, objects take on hard, brittle characteristics and don't lose these properties when wet.

Different processes occur at different temperatures in the firing process. The firing process proceeds through a number of steps:

- (1) Added vegetal matter burns off (200-600°C).
- (2) Clay decomposition begins as water is lost from the structure (400-700°C).
- (3) Carbon and sulfur are burned out (700-900°C).
- (4) Sintering occurs as the heat is raised and particles in the ceramic object begin to join together at points of contact. Sintering gives cohesive strength to low-fired ceramics.
- (5) Vitrification takes place at higher temperatures (depending on the mixture of clay and fluxes). During vitrification, melted particles flow together and the object as a whole will shrink. Vitrified ceramics are non-porous; not all ceramics are completely vitrified.

Ceramics are loosely divided into four groups. These groups are based on their firing temperature, clay type, and physical characteristics:

- ***Adobe or mudbrick*** is an unfired clay mixture. This material is often used for building, but mudbrick objects, such as cuneiform tablets and sculpture, are often found in museum collections.
- ***Earthenware*** is a low-fired clay mixture. These objects are fired between about 950-1100°C. At this low temperature sintering occurs but not vitrification. Earthenware is generally soft and scratches easily. It is often red in color from naturally occurring iron in the clay; brown, black, and yellow are also common colors. Earthenware has the following characteristics:
 - It is porous and will readily absorb water unless glazed.
 - The structure is often granular in appearance with numerous coarse particles.
 - There is a clear distinction between the ceramic body and any glaze layer.
- ***Stoneware*** is fired between 1100-1350°C. Stoneware objects are partially vitrified. Common colors for stoneware are buff, brown, and gray. Stoneware has the following characteristics:
 - It is partially vitrified and less porous than earthenware.
 - It is harder and denser than earthenware and does not scratch easily.
 - If tapped lightly, the body will give a distinctive ring.
 - The glaze and body are tightly adhered.

- **Porcelain** is fired at very high temperatures, usually above 1300°C. Porcelain is made of a special clay called kaolin. This clay is difficult to work and must be fired under precise conditions. Porcelain can be formed into objects with thin, complex structures. Porcelain has the following characteristics:
 - The body is completely vitrified and impervious to water (non-porous).
 - The clay body is white and translucent and extremely hard and brittle.
 - When tapped lightly, the object rings with a higher tone than stoneware.
 - In cross-section, glaze and body are nearly indistinguishable.

4. *What surface treatments are used for ceramics?*

Potters frequently add materials to the surface of the ceramic body both to decorate it and to make it less porous. These materials are either fired on or applied after firing. Fired-on materials are usually more stable. These materials include:

- **Glazes:** These are vitrified surface coatings that vary widely in appearance and can be divided into three categories:
 - **Lead glazes** are made of the mineral lead oxide, mixed with other materials. Lead oxide melts at a low temperature. Lead glazes characteristically produce smooth, glassy surfaces, but can be easily scratched. Lead glazes can be a health hazard. Weak acids found in foods such as tomatoes, vinegar, and fruit juice can dissolve the glaze, releasing lead that can be ingested. However, if glass powder (frit) is added to the glaze using proper techniques, these glazes are non-toxic.
 - **Alkaline glazes** contain alkali fluxes such as sodium, lithium, or potassium. They are also fired at low temperatures. Alkaline glazes usually have brilliant colors and may craze or crawl. They are not very durable and scratch easily. If not adequately fritted, they can remain slightly soluble after firing.
 - **High-fire glazes** are primarily feldspar and are used on stoneware and porcelain. These glazes are glass-like and form a hard, smooth, and durable surface. The colors produced are generally more subdued than in low-fire alkaline and lead glazes.
- **Slip or engobe:** A slip or engobe is a thin layer of colored clay that the potter applies on the surface before the first firing. It generally appears matte (not shiny like most glazes), but may be burnished to get a smooth lustrous look. A potter may also use a brush to apply decorative elements over the slip.
- **Underglaze:** Underglaze painting is generally used to add fine detail. The potter paints these decorative touches onto the surface of ceramics

after the first firing (bisqueware) (see Section B.5) and then applies a protective transparent glaze.

- **Overglaze:** Overglaze is used to provide additional decoration to the surface. The potter can apply overglaze decoration in two ways. In one technique, the artist will brush details onto a background of unfired clay and fire the glaze and overglaze at the same time. In the other, two-step technique, the artist applies the overglaze after the glaze has been fired and fires the piece again at a low temperature. Objects produced with the second technique are not as durable as higher-fired glazes.
- **Other materials:** Potters may apply other coatings or materials to ceramics, such as gesso, resins and waxes, or powdered minerals. These coatings are applied for a variety of decorative and functional reasons.

5. *How are ceramics formed?* Potters will use one or more of these techniques to produce ceramic objects.

- **Hand-built ceramics:** These are crafted using the oldest methods of producing ceramics. Potters roll out flat slabs of clay and assemble a form by pressing the slabs together or they may pinch and manipulate a ball of clay into a small object. They can form coil-built vessels by first shaping long ropes of clay, coiling them into a basic shape and then pinching and shaping the coils into the final form.
- **Wheel-thrown ceramics:** The potter shapes the vessel on a rotating wheel. You can often identify these pieces by looking for a flat base with concentric striations on the surface. Vessels are sometimes coil-built and then finished on a wheel.
- **Mold-pressed ceramics:** These are made by pressing a slab of clay into an open mold. This technique is often used for shallow shapes (like plates) that are difficult to throw on a wheel.
- **Slip-cast ceramics:** This method is often used for delicate porcelain objects. The potter pours a slurry of clay into an absorbant plaster or ceramic mold. The water is drawn from the slurry leaving thickened clay behind. Delicate and complex objects can be made with this method.

6. *What flaws might I find in ceramic objects?* It is important to recognize the flaws that may occur during the manufacturing process so you can separate flaws from damage or active deterioration.

- **Ceramic body flaws:**
 - *Warping* may result from uneven heating or cooling during firing.
 - *Spalling* or *delamination* of parts of the clay body can result if the firing temperature is not high enough.
 - *Sagging* is caused by firing at a temperature that is too high for the clay body.
 - *Cracking* will occur if the object is cooled too quickly.

- *Bloating* occurs when heating is too rapid. The gases that are formed during firing don't have enough time to be released and are trapped in the body.
- **Glaze flaws:**
 - *Crazing* is a fine network of cracks on the surface of the glaze. Crazing results when the glaze is under tension because it has contracted more than the clay body during cooling. It may develop immediately or sometime after firing. Overtiring or rapid cooling can also cause crazing. It is sometimes used as a decorative technique.
 - *Shivering* results when the glaze shrinks less than the clay body. The glaze may peel or flake off the surface.
 - *Crawling* describes the shrinking of the glaze into islands, revealing bare areas of clay. The defect occurs when glaze is applied over a dirty or greasy clay surface and does not adhere properly during firing. Potters may purposely leave areas unglazed.
 - *Pitting* in the glaze can vary in size from pinholes to larger spots. Pits occur when firing temperature is raised and lowered too quickly and volatile materials don't fully escape before the glaze solidifies. Pits may also occur if a vessel is fired at too high a temperature causing the glaze to boil.
 - *Blistering* results when air is trapped between the glaze and the clay body. These surface bumps are easily crushed. This problem often occurs when glaze is applied too thickly.

C. The Nature of Glass Objects

Glass has been used for personal adornment, containers, construction materials, and a host of other purposes throughout the last four millennia. In order to understand how to preserve glass objects, you must understand how they are produced.

1. *What materials make up the structure of glass objects?* The basic materials of glass are silica and alkaline oxide (also known as flux). Silica generally comes from sand or crushed flint. The flux interacts with the silica and lowers the melting temperature. Typical fluxes include lead, calcium, potassium, and sodium oxides. Other oxides (iron, copper, cobalt, manganese, chromium and nickel) are added as colorants. When melted, this mix of materials flows readily to form various shapes.

Glass is a unique material—a rigid liquid. A liquid is an amorphous material that does not have an organized, crystalline structure. Most materials, such as metals, form a crystalline lattice as they cool from a liquid to a solid state. Molten glass, however, cools too quickly for this structure to form. The structure is "frozen" into a random network of molecules. Glass is rigid and

brittle at room temperature. Depending on the materials included in the mix, it can be transparent, translucent, or opaque.

Glazes and enamels are also glasses with small differences in composition from bulk glass. Glazes are applied to ceramics; enamels are usually applied to a metal support. Glazes and enamels are generally opaque and fired at lower temperatures than glass.

Both hot- and cold-working techniques are used to make glass objects. Generally, the artist forms the object using hot-working techniques. Cold working techniques are used to embellish the surface.

2. *What are the hot shaping processes?*

There are six hot-shaping processes:

- ***Mouth blowing*** begins by gathering a lump of molten glass at the end of a hollow pipe. The worker blows air into the pipe by mouth or with a bellows (which may be automated). Metal tools such as shears or rods are used to help shape the object. Glass can also be blown into a metal, stone, or wooden mold. A mold-blown object may be further hot-worked after it is removed from the mold.
- ***Glass pressing*** is a technique in which molten glass is pressed into a mold with a metal tool. The technology for this method developed in the 19th century and made glassware widely available.

You can sometimes identify pressed and molded glass by mold lines, though these lines are often ground and polished away.

- ***Core dipping or winding*** is the oldest technique used in making glass vessels. A core of organic material (for example, dung or straw) is mounded onto the end of a rod and coated with sand or clay. This core is dipped into molten glass or wrapped with coils of glass. To produce a consistent structure the glass is heated and rolled over a smooth surface. The core is removed after the glass has cooled.
- ***Pâte de verre*** means literally glass paste. Glass is ground to a powder and mixed with an organic adhesive so it can be molded or modeled much like pottery. After forming, the object is fired to burn away the organic adhesive and to fuse the glass paste. The resulting glass is usually opaque.
- ***Lost wax casting*** is a technique in which a wax model is created, covered with clay, and fired to melt out the wax. Molten glass is poured into the void left behind.
- ***Millefiore*** glass is produced when different colored rods of glass are wrapped with layers of colored glass and heated. The package of glass is rolled on a textured surface to work together and shape the layers. Each thick rod is then cut into short lengths that show a floral design in cross section. These lengths are then used to form objects.

Decorative details can be added to molten glass by fusing colored glass onto the surface of the object or by integrating glass threads or shapes into the body and then reheating.

3. *What cold-working techniques are used to decorate glass?*

Commonly used cold-working techniques used to decorate a glass object after it has cooled include:

- cutting or engraving the glass with a sharp point or cutting wheel
- chipping away the glass inside an engraved design outline
- acid etching a design in the glass (The glass surface is coated with wax and a design is cut through the wax. The piece is then dipped into hydrofluoric acid to etch the exposed glass. This technique has been used since the 19th century to decorate glassware.)

The final step with all these techniques is to polish away surface roughness and imperfections.

4. *What flaws might I find in glass objects?*

Flaws can be introduced during the manufacturing process. Learn to distinguish these flaws from active deterioration problems. Look for:

- **Bubbles:** They may also be added intentionally for decorative effect. A few isolated bubbles will not weaken a glass object, however, a cluster of bubbles might. The shape of the bubbles gives clues to the direction that the object was worked in the molten state.
- **Inclusions or foreign bodies:** These are more noticeable in translucent glass. Often these flecks come from contamination in the crucible or impurities in the raw materials. Small inclusions may disrupt the surface and look of an object, but they will not affect its strength.
- **Compositional flaws:** Sometimes these are not apparent for many years. The symptoms of deterioration from compositional problems are covered in Section E, Agents of Deterioration.

D. The Nature of Stone Objects

Stone in museum collections is often perceived as a material with few problems, but stone is brittle and can break or shatter. While generally, harder and tougher than many other materials found in collections, the agents of deterioration also can affect the preservation of these materials. It reacts with the environment in a variety of ways. Understanding the origin and production of stone objects in your collection will help you identify problems.

1. *What materials make up the structure of stone objects?*

Geologists divide rock into three broad categories:

- **Igneous rocks** are formed when magma cools and solidifies. They are generally hard and very stable because of their interlocking crystalline structure. Types of igneous rocks are granite, basalt, obsidian, and porphyry.
- **Sedimentary rocks** are formed by the solidification or cementing together of layers of organic and mineral sediments. They are usually more permeable and deteriorate more easily than igneous rock. Examples include sandstone, limestone, alabaster, and travertine.

- **Metamorphic rocks** are formed by transformation of igneous or sedimentary rocks with pressure and heat. The structure depends on the parent rocks. For example, marble is metamorphosed from limestone.

The durability of stone depends on its porosity, permeability, hardness, mineral content, and number and type of inclusions. Porosity is the amount of free space in a rock; permeability is the capacity of a rock to allow fluids to pass through it.

2. *How are stone objects formed?*

Stone-working tools and techniques have changed little through time. Although metal tools have replaced stone and, more recently, electric power has speeded up some processes, modern artists use the same basic tools to carve stone. Workers use heavier and thicker tools for carving hard, igneous stones (for example, granite), than for softer limestone and marble. They must also temper steel tools used on hard stones, hardening them by heating, cooling, and slow warming.

The carver holds a carving tool in one hand and uses a hammer or mallet to strike the tool. Stone surfaces are often polished to remove tool marks, but sometimes you can find traces on back surfaces or inaccessible undercuts that can be used to identify techniques. Sculptors use six basic tools:

- **Point (punch):** After selecting a stone, the sculptor uses a point for roughing-out the shape from the block. The sculptor holds the point at an oblique angle to the stone surface and hits it with a hammer. Larger masses of stone are removed, progressing from larger to smaller diameter points.
- **Tooth chisel (claw chisel):** Following the initial roughing-out, the sculptor uses the tooth chisel to remove more layers of stone and further define the form. The tooth chisel is used primarily on limestone, sandstone, and marble. The sculptor will start with a coarse chisel with well-spaced teeth and progress to a fine chisel with closely spaced teeth. You can identify the tooth marks angled in different directions. Using this tool gives the stone a raked or combed appearance.
- **Bushhammer:** Sculptors use a bushhammer on hard stone such as granite. The bushhammer is a series of points or teeth in one head (multi-pick) used to wear down or pulverize a hard stone surface. As when working with a tooth chisel, the sculptor progresses from coarser to finer toothed bushhammers. The bushhammer gives the stone a pitted, granular appearance.
- **Flat chisel:** To remove the marks of the tooth chisel and bushhammer, the sculptor often uses a flat chisel. The sculptor holds the flat chisel almost parallel to the surface of the stone and cuts across to remove the rough surface material. On concave surfaces, a rounded chisel edge may be used. Sculptors sometimes use only a flat chisel when carving soft stones or producing low-relief carvings.
- **Abrasives:** Rasps, rifflers, and files are abrasive tools. They are used to do rough finishing. Mineral and stone abrasives such as sandstone, pumice, and carborundum (silicon carbide) are used for shaping and smoothing. Sculptors used emery cloth, solid tin oxide, and sandpaper

for finishing the surface. Whiting (calcium carbonate) is used for final polishing. A sculptor may stop at any point in the surface finishing process depending on the desired look.

- **Drills:** To split stone the worker drills a series of holes along a stone face and then hammers wedges into the holes. You may see evidence of this technique as a line of parallel vertical marks left by the drill on the face of the stone.

3. *Will I see different techniques used on archeological stone objects?*

Flaking methods were used to produce the stone tools found in many archeological sites. Flint or chert and obsidian were used for tools because they flake easily and give a sharp edge when fractured. You can identify the fracture face by the conchoidal fracture, a series of concentric arcs radiating from the point of impact. You can identify the point of impact by the bulb of percussion, a swelling caused by the compression of the blow.

There are two basic methods for detaching a flake:

- **percussion flaking**, where the core or parent block is struck with another stone
- **pressure flaking**, where heavy pressure is applied with a stone, bone or wooden tool

Early stone tools were also drilled and abraded with sand, just like wood, bone, stone or early metal tools.

4. *What different tools and techniques are used on contemporary sculpture?*

Though the basic tools used for modern stone sculpture are the same as those used in the past, the addition of pneumatic equipment speeds the process and makes working stone less physically difficult. Wire saws, diamond saws, and flame cutters are now available to cut and roughly shape stone.

Pointing is a contemporary mechanical process used to duplicate an original model. A pointing machine, a movable instrument with adjustable rods, mechanically measures a number of points on the original and transfers these to the stone block. Holes are drilled into the stone to the point and depth measure with the pointing machine. The stone between the drilled holes is chiseled away. Finer pointing is employed as the reproduction progresses.

Other mechanical aids are also used to produce reduced or enlarged products from a model.

E. Deterioration of Ceramics, Glass, and Stone

You can find general information on the agents of deterioration that affect ceramics, glass, and stone in Chapter 3: Preservation: Getting Started, and Chapter 4: Museum Collections Environment.

The agents of deterioration that can have the most profound effect on ceramics, glass, and stone in museum collections are direct physical forces. If ceramic or glass objects are dropped, they usually break. Most stone will chip, crack, or break if dropped. Cumulative damage can occur with improper handling—pieces can be chipped off and residues left from

handling. Some ceramic, glass, and stone objects also have flaws, either inherent or from their previous use, that make them vulnerable to heat or moisture.

1. *How do ceramics deteriorate?*

Besides the obvious problems of breakage, ceramics can be vulnerable to changes in temperature and relative humidity. In particular, archeological ceramics may contain "soluble salts" that can crystallize at or near the surface and destroy decoration or even the ceramic structure. See *Conserve O Gram* 6/5, Soluble Salts and Deterioration of Archeological Material. Other historical objects (for example, salt containers or pickling jars) that held contaminants can suffer similar damage.

Unstable glazes may become crizzled and crazed, deterioration problems common to glass and discussed in more detail below.

2. *How does glass deteriorate?*

Most damage to glass is mechanical. It is easily broken and chipped. Water is the major chemical agent of deterioration for glass and the susceptibility of glass to deterioration depends greatly on its original chemical structure. Some deterioration processes are caused by similar reactions, but have different visual characteristics. Be aware of the following deterioration types:

- **Crizzling** is a fine network of surface cracks that turn glass translucent. Moisture in the air reacts with unstable glass containing too little lime (calcium oxide). The moisture causes potassium and sodium in the glass structure to leach out. As the structure weakens, small cracks appear.
- **Weeping** is caused by leaching sodium or potassium absorbing water on the surface of deteriorating glass to form sodium or potassium hydroxide. These compounds accumulate on the surface of the glass and may give it a greasy feeling. The hydroxides may also react with carbon dioxide in the atmosphere to form carbonates, which can absorb even more water.
- **Crusty or waxy deposits** on the surface, which may have a white crystalline appearance, are typically seen on ethnographic beadwork and may be a reaction of the glass deterioration products to oils in adjacent leather.
- **Iridescence** is a rainbow-like effect on the glass surface and is an indication of deterioration. The colors are visible when light is diffracted between the air-filled layers of deteriorated glass.
- **Devitrification** is the production of small areas of crystal growth in the otherwise amorphous glass structure. These crystals may be intentionally produced during production as they give glass good thermal shock resistance. Unintentional devitrification is caused by unstable glass with too much alumina or too much calcium.
- **Solarization**, a process that can cause some glass to turn purple or brown, is caused by exposure to sunlight over long periods of time. This deterioration can sometimes be seen in old window glass.

3. *How does stone deteriorate indoors?*

Stone is affected by agents of deterioration—especially when it is not well protected in storage or it is put on exhibit. You must be aware of how damage can occur and how you can protect stone.

- **Dirt and dust** accumulate on horizontal surfaces and in nooks and crannies in stone objects. It disfigures the object and over time the dirt can penetrate porous stone and cause staining. High traffic areas will have greater accumulation of dirt.
- **Oils** from repeated handling will also cause stains. This is typically seen on protrusions such as noses or knees on sculpture that are accessible to visitors.
- **Old coatings of wax or oil and old adhesive repairs** may also discolor over time. Staining will be most noticeable on light colored stones and may have a blotchy appearance.
- **Relative humidity** that is fluctuating or too high can also cause damage. Fluctuating humidity can bring salts to the surface and cause spalling. High humidity can react with pollutants and damage stone, just like in an outdoor environment.
- **People** can cause a lot of damage to stone objects indoors. Breakage and chipping from handling are obvious examples. Graffiti from vandals, paint drips and smears from careless maintenance, and damage from splashed cleaning fluids are other examples.

4. *How does stone deteriorate outdoors?*

Stone is often exhibited outdoors where it is not well protected from the agents of deterioration.

Water causes most of the damage to stone stored or exhibited outdoors. Water can penetrate between the layers in sedimentary rock and push them apart. Water carries salts, such as chlorides, into the stone and as these crystals dry they can damage the surface of the stone (see *Conserve O Gram* 6/5). During the winter, when water freezes, the expansion of the ice can cause cracking, splitting, and spalling. **Corrosion** of metal components that may be attached to the surface, mounted into the stone, or used as interior supports in some cases causes severe damage. Copper corrosion will produce green stains; rusting iron produces brown stains. As metal corrodes it expands. Expanding internal supports can crack apart the surrounding stone. Also be aware that some solutions used to clean mounted metals may stain the stone support.

Atmospheric pollutants can react with water and cause damage. Carbon dioxide and water form carbonic acid that can dissolve calcium carbonate, a major component in limestone and marble. Other sources of acid that attack stone come from the reaction of water with chlorides, nitrates, and sulfur. Other chemicals from car exhaust and industrial pollution react with carbonates to create disfiguring brown and black layers on the surface or simply adhere to stone and discolor the surface. Abrasive particles carried by the wind can wear away surface detail.

Biological agents such as bacteria, algae, fungi, and moss grow on stone surfaces and inside cracks pushing them further apart. These agents also retain water and contribute to the damage caused by water and atmospheric pollutants. Their organic waste products can dissolve calcium carbonate. Biological agents can also cause staining. Birds can disfigure and damage stone with their waste.

5. *Should I move stone objects indoors?*

The best way to protect stone objects stored outdoors is to move them inside. This action radically limits the agents of deterioration that will contact the objects. However, be aware that moving an object indoors is a major environmental change and you should carefully examine the object before moving it. Monitor the object after it is brought inside. Most objects will dry out when moved indoors. As water is lost from the interior, residues left by pollutants, biological matter, cleaning agents, and soluble salts may begin to crystallize on the surface. Where previously they were washed away by rain, they can now cause damage to the stone and may require treatment. Mold may grow on dirt and biological waste accumulated on the surface when it was outside.

F. Preventive Conservation

1. *What special handling rules for ceramic and glass objects should I know?*

Follow these special rules when handling ceramic and glass objects:

- Handle glass and ceramic objects as little as possible.
- Before handling, examine the object carefully. Note any unstable repairs, loose parts, lifting glaze, hairline cracks, or vulnerable appendages.
- Don't wear cotton gloves to handle glass or ceramics because the surfaces are slippery. Use clean, bare hands or snug fitting latex or nitrile gloves. In particular, use latex gloves for lustreware, iridescent glasses, and gilded ceramics and glass. The moisture, oils, and acids left from bare hands will disrupt and eventually etch these delicate surfaces.
- Don't lift objects by handles, knobs, rims, or decorative motifs. ***Always use both hands to support the object uniformly.***
- Transport ceramic and glass objects in a padded container. Don't stack objects. Don't allow objects to knock together. If you are moving numerous objects, use a well-balanced and padded cart with a lip at the edge of the surface. Use plenty of soft tissue or cloth diapers to prevent objects from rolling and tipping.
- Transport detachable parts such as lids or bases separately. If there are loose (but not removable parts), slip tissue or polyethylene foam between the parts to prevent rubbing or bouncing.
- Carry thin, flat objects, such as mirrors or panes of glass, vertically. This position distributes the weight and minimizes the chance of cracking the object. If the object is heavy, you may need to use a dolly or hand truck and assistance from other people. Be sure the dolly has soft wheels and all surfaces are cushioned.
- Never apply tape or sticky labels to ceramic or glass objects. When they are removed, delicate overglazes, decals, and gilding may be removed as well. Tape and labels will also leave residues on the surface of the objects that may cause staining or attract dust.

Refer to Chapter 6: Handling, Packing and Shipping Museum Objects, for basic rules on handling museum objects.

2. *What special handling rules for stone objects should I know?*

Follow these rules:

- Wash hands and wear clean, white gloves.
- Always take care when placing your hands on a surface. Paint, gold leaf, and delicately carved areas can be damaged. Previously repaired areas may not be stable.
- Always carry one item at a time and never lift by projecting parts such as arms, legs, or wings.
- Use a cart when moving an object more than a few feet or when moving more than one object. Use padding, wedges, and blankets to stabilize objects and prevent them from touching and abrading each other.
- You may need to use a forklift to move large, heavy stone sculpture. Be sure you have enough help when moving large objects. Make sure straps or chains that secure the object are well padded and cannot slip and scratch the surface. Cover and pad protruding parts. Make sure the object is properly supported on the forklift before putting your hands underneath the object.
- Be sure that equipment used around large stone objects (ladders, scaffolding, other maintenance equipment) is used carefully.

3. *What environmental parameters should I use for ceramic, glass, and stone objects?*

See Chapter 4: Museum Environment, for a discussion of how to set temperature and humidity ranges for your objects. In general, objects should be maintained in a stable temperature and relative humidity with no more than +/-5% variation in a day.

A few types of ceramic, glass, and stone objects will need special consideration when developing their museum environment because of deterioration problems.

- ***Deteriorating glass objects:*** Unstable, weeping and crizzling glass and glass that appears cloudy or iridescent or is suspected of being unstable for some other reason should be stored in a stable microenvironment. The humidity must be tightly controlled: too high and deterioration will progress; too low and cracking may occur. Contact a conservator for advice on how to prepare a microenvironment to store unstable glass. See *Conserve O Gram* 1/8, Using Silica Gel in Microenvironments, for information on using silica gel to buffer the environment.
- ***Archeological ceramics and stone:*** Archeological ceramics and stone may have absorbed soluble salts from burial. (See *Conserve O Gram* 6/5.) These objects must be stored at a low and stable relative humidity. If fluctuations occur, the salts can move through the porous ceramic structure and crystallize near the surface to cause damage.
- ***Composite objects:*** If ceramic, glass, or stone objects are combined with other materials, particularly organic materials, use the environmental parameters recommended for the organic materials. For example, keep stone objects framed in wood in an environment that will preserve the wood. Store polychrome sculpture in a stable environment to protect the painted surface.

4. *What light levels should I set for ceramics, glass, and stone?* Visible or UV light will not damage most ceramics, glass, and stone. Light will not deteriorate inorganic materials. Infrared (IR), however, can cause damage, by heating objects and by causing changes in relative humidity around the object. These RH fluctuations can cause salts to crystallize out or cause slight expansion and contraction of surfaces. Keep light fixtures outside of exhibit cases. Don't use spotlights directly on objects. See Chapter 4: Museum Collections Environment, for a discussion of light and light levels.
5. *How should I store stable ceramic and glass objects?* Choose storage solutions that will minimize handling and thus the chance of breakage. Design the storage area so that access is safe, simple, and direct. See Chapter 7: Museum Collections Storage, for more complete information on storage design and choosing cabinetry.
- Cabinets should be in a low traffic area in the storage room to reduce the chance that people will bump into them.
 - Store ceramics and glass on stationary shelves to avoid damage from vibration. Line shelves with closed-cell polyethylene foam (Volara®). Attach the foam with double-stick tape so it will not bulge or slide.
 - If possible, choose museum cabinets with clear glass doors to allow visual access without handling. Don't store other light sensitive objects in these cabinets. All cabinets should have gaskets and close tightly to minimize dust accumulation. See *Tools of the Trade* for information about storage cabinets. See also, *Conserve O Gram 4/3*, Installing the Retrofit Gasket Kit.
 - If possible, choose shelves that are only deep enough to accommodate a single object. This limits the need to move one object to retrieve another. Place small objects in rows with ample space to reach one object without touching another.
 - Store the heaviest objects on the bottom shelves.
 - Don't stack plates, cups, and bowls. If a critical lack of space requires stacking, place soft fabric, such as washed, white cotton flannel or polyethylene foam, between each object. Make sure the objects nest well and don't put pressure on each other.
 - If objects are unsteady due to their shape or to damage, store them in a stable position using padding or foam blocks. See Figure P.1 for an illustration.
 - Pieces of broken glass and ceramic objects should be kept together. Pad pieces so they don't abrade each other and keep them together in a tray or box.
 - Use dust covers on open shelving. See *Conserve O Gram 4/2*, Dust Covers for Open Steel Shelving. If oversized objects must be stored in the open, they should be covered with a polyethylene bag or dust cover.
 - Stabilize shelves by bolting them to walls and ceiling. Open shelving should have earthquake bars.

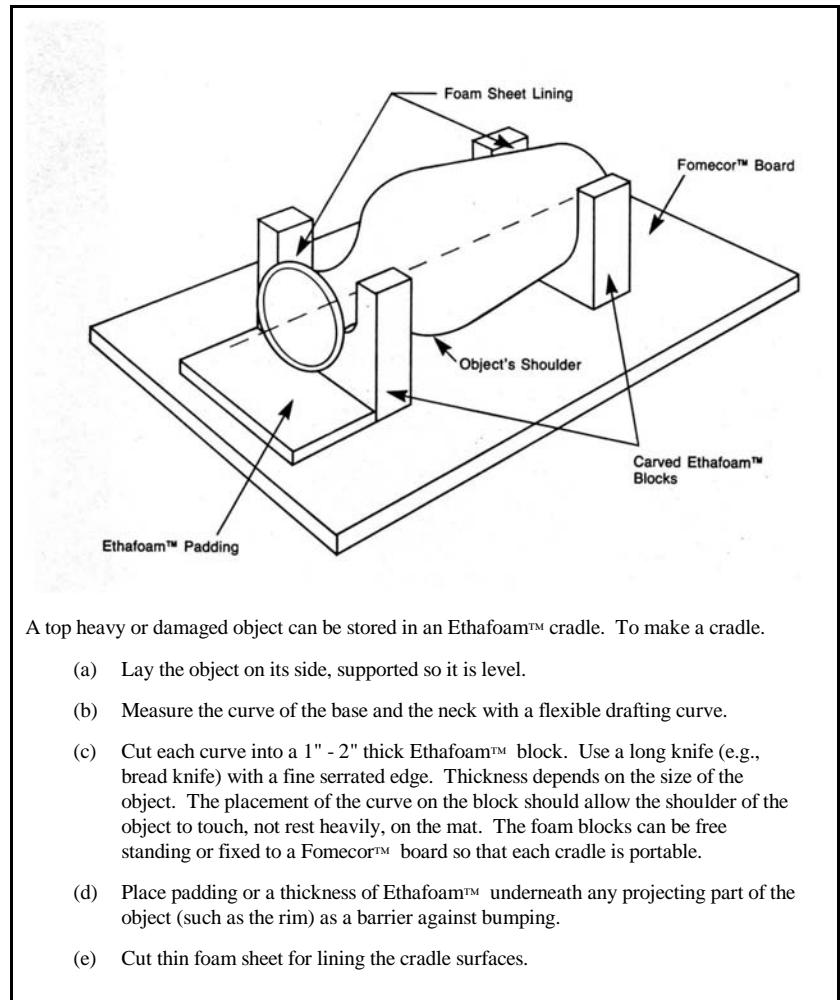

Figure P.1. Method of Stabilizing Objects in Storage

See *Conserve O Gram* 14/5, Caring for Photographs: Special Formats, for information on the special housing and storage needs of glass plate negatives and transparencies.

6. *Are there special storage concerns for unstable glass and ceramics?*

You may need to store unstable glass or ceramics in a microenvironment that keeps the relative humidity at a lower level than the general storage environment. Low RH slows the deterioration of weeping glass and ceramics with soluble salts.

Before taking this step, carefully discuss the need for this option and the design of your storage system with a conservator. Creating a microenvironment generally requires long-term maintenance, and if it fails, more harm may come to the objects than if you had done nothing.

You may create a closed microenvironment in:

- an individual container, such as a polyethylene box with a tight fitting lid (Rubbermaid®, Tupperware®)

- a fishtank with a plate glass top
- a single museum cabinet

Use silica gel buffered to 40% RH to control the microenvironment. See *Conserve O Gram 1/8* for an explanation of how to buffer silica gel and how to figure the quantity of silica gel needed in your container.

Your storage system must isolate the object from the silica gel. ***Don't let the silica gel touch the object.*** Work with a conservator to develop the best storage system for your particular objects. You need to consider the following:

- How many objects do I need to store?
- What size are the objects?
- What shapes are the objects?
- How fragile are the structures of the objects?
- How fragile are the surfaces of the objects?

7. *What are the storage requirements for stone objects?*

Keep in mind the following points when developing a storage system for stone objects:

- Keep dust from the surface of stone objects. Dirt and dust can accumulate in the pores and darken the surface. Use individual polyethylene bags or muslin dust covers (see *Conserve O Gram 4/2*) to keep dust from settling on objects in storage.
- Keep objects away from open windows, air conditioning vents, and heat sources.
- Small objects, such as arrowheads and beads, should be stored in individual bags or boxes so that they are not easily lost.
- Large stone objects present problems because of their weight. Be sure your shelving units can support the weight of the object. Use polyester felt as a shelf liner for heavy stone objects because it will not compress as much over time as polyethylene foam.
- Store heavier objects on bottom shelves. This lowers the center of gravity and minimizes the danger of a rack toppling over.
- Don't allow any part of an object to protrude beyond the edge of shelving where it might be bumped.
- Don't store large sculptures directly on the floor. Create a low deck or use pallets at least four inches off the floor. Raising objects protects them from floor cleaning chemicals and minor flooding.

- Allow sufficient space between objects so that they can be easily moved and periodically inspected. Large objects especially need enough space so they can be handled without knocking other nearby objects. If heavy pieces are regularly moved, store them on dollies with lockable wheels.
- In earthquake prone areas, use earthquake stabilization techniques. Securely bolt shelves and cabinets to walls and floors. Attach restraining bars to the edges of shelves. Be sure overhead lights, pipes, and ductwork are also reinforced.

8. *What special preventive conservation concerns should I have for ceramic, glass, and stone objects on exhibit?*

Exhibiting an object puts it into contact with many more agents of deterioration. See *MH-III*, Chapter 7: Exhibits, for an overview of preservation concerns when objects are put on exhibit. *Exhibit Conservation Guidelines* by Toby Raphael is also a useful guide to incorporating preservation in your exhibit.

Work with a conservator and experienced designers and mountmakers to ensure exhibit techniques will not damage objects. Heed the following when designing a new exhibit or evaluating ways to improve your current exhibit.

- Make sure all objects are securely mounted so that they cannot fall if the case or pedestal is bumped. Construct mounts from stable materials and attach them so they don't put undue physical stress on the objects. Use seismic stabilization mounts in earthquake-prone areas.
- Don't direct spotlights on individual objects. Spotlighting can cause thermal shock as well as raise the interior temperature of the case.
- If sculpture is exhibited outside a case, be sure to provide a physical barrier so it cannot be touched. Use a pedestal or a deck to raise the objects up off the floor. Make the pedestal large enough that it cannot be easily ignored by visitors trying to reach the work of art.
- Busts and small stone objects must be securely mounted to prevent them from toppling over. A variety of techniques can be used to mount the object. Work with an experienced mountmaker and a conservator to design a safe mount.
- Don't plaster or cement stone reliefs directly into the wall. They will be difficult to remove later and moisture and salts from rising dampness can infiltrate the object from the wall.
- When cleaning objects on display, brush the dust off into a vacuum; don't use a cloth. See *Conserve O Gram* 8/1, Removing Dust from Ceramic and Glass Objects.
- If stone sculptures are exhibited outdoors, you should develop an annual monitoring program to watch for deterioration. Conduct a careful condition survey and document the sculpture with detailed photographs. Consider having a conservator conduct a Collection Condition Survey to give you baseline information and train staff in evaluating deterioration. If objects are deteriorating rapidly, they should be brought indoors. Consider putting a replica in place of the original. Refer to *MH-III*, Chapter 5: Three Dimensional Reproductions.

G. Care of Composite Ceramic and Glass Objects

Composite objects are museum objects made of more than one material. These materials can react to the environment differently, setting up stresses that may cause the object to deteriorate more quickly than one made of a single material. Glass, in particular, was used in many types of composite objects and may be sewn or attached to a variety of materials. Be sure to take into account the preservation of all parts of the object. For example, never use water to clean glass beads sewn onto costumes. You may damage the attachment thread and the fabric or leather of the costume.

Two types of composite ceramic and glass objects that have special preservation concerns are:

- **Mirrors:** Look closely through the front of the glass to see if any silver-colored droplets or beads have formed on the back of the glass. Before the 19th century, mirrors were made reflective with a toxic mercury/tin amalgam. This coating can break down. Look for droplets collected at the bottom of the frame. Always wear disposable plastic gloves when handling mirrors you suspect may have a mercury coating. Contact a conservator to examine an unstable mirror.

For all mirrors, examine the glass carefully. Do you see breaks or chips in the glass? Is the glass sticky (weeping glass), or does it have an overall network of very fine cracks (crizzling)? Is the coating on the back still reflective, or do you see black spots or streaks that indicate deterioration or peeling?

Be sure the glass is securely attached to the frame and the frame is in good repair. Store heavy framed mirrors face up on well-padded shelves. Support the frame with padding. Make sure that all the weight is not resting on the mounting hardware or the glass.

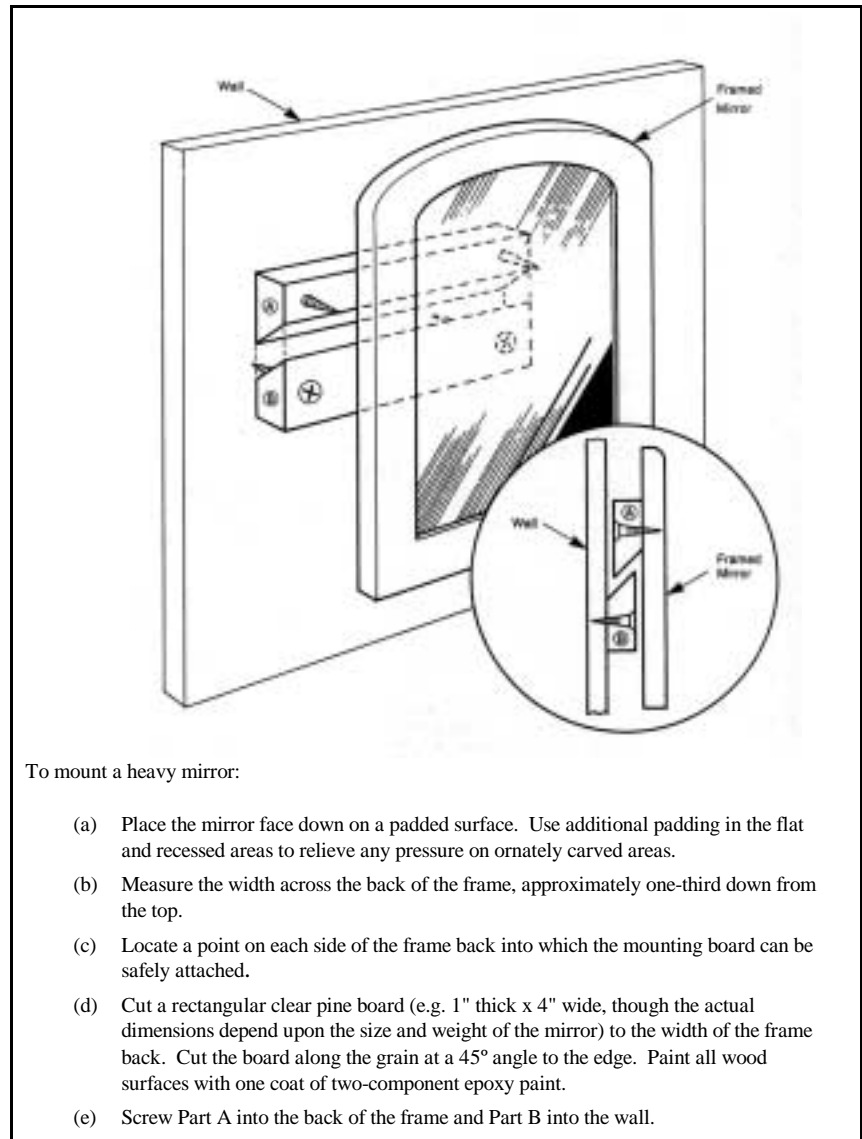

Figure P.2. Flush Mount for Hanging Heavy Mirrors

- **Chandeliers:** Look closely to identify parts that are fixed and parts that are free to move before cleaning or moving a chandelier. Ask the questions:
 - How secure are the hooks and joints?
 - Are there any missing prisms or other parts?

Chandeliers on display in the open air, for example in historic houses, will need to be dusted occasionally. Use a scaffold or sturdy ladder to reach the chandelier so you can keep your hands free and safely move around the chandelier. Move furniture and other items on the floor away from the ladder. Dust prisms or moving parts individually so they don't knock into each other. Follow the instructions for dusting found in *Conserve O Gram* 8/1.

When a chandelier is not on view (for example, when a house is closed for the winter) or has been placed in storage, cover it with a muslin or polyethylene bag to keep it clean. Mark light switches or turn off the power at the fuse box so covered lights will not be turned on.

H. Treatment Issues for Ceramic, Glass and Stone Objects

The following section discusses particular considerations before any treatment is carried out either by park staff or a conservator. See Chapter 3: Preservation Getting Started, and Chapter 8: Conservation Treatment, for general information on working with a conservator. When you work with a conservator, you will need to make choices about the type of treatment that is appropriate for your objects.

If objects are not stored in closed cabinets, for example, on display in a historic house, trained museum staff should dust them. This basic maintenance will avoid the need for more difficult and more expensive cleaning in the future. Follow the instructions in *Conserve O Gram* 8/1, Removing Dust from Ceramic and Glass Objects.

1. *What should I consider before cleaning ceramic and glass objects?*

If objects are dirty enough to require washing, you should work with a conservator to develop a cleaning program. Before placing any ceramic or glass object in water, determine that:

- the ceramic is actually fired
- the glass or ceramic is intact
- there are no previous fills
- no surfaces are powdery, sticky, or crackled
- there are no stains that might migrate

If any of the above conditions is not met, don't wash the object.

2. *What should I consider before cleaning stone objects?*

Stone objects stored indoors should be regularly dusted. Don't wash stone objects. If stone objects are very dirty, get advice from a conservator. Don't use commercial cleaners without the advice of a conservator; many contain acids that can dissolve the stone. Problems that can occur with wet cleaning include:

- stains that move further into the stone, instead of washing out
- loss of polish on soluble stones such as alabaster
- movement of soluble salts that then crystallize and damage the surface of the stone as it dries

3. *How can I tell if an object has been repaired?* You may be able to identify repaired areas using one of the following methods:
- Examine the surface with a magnifying glass in good light to identify breaks.
 - Examine the surface with a hand-held ultraviolet light to identify cracked glaze, fills, adhesive lines, or painted surfaces. Different materials will fluoresce differently and some will not fluoresce at all, allowing you to identify damage and repairs that may not be visible to the naked eye.
 - Test different colored areas on the surface in inconspicuous areas with a slightly damp cotton swab to confirm that they are truly glazed.
4. *Should old repairs be removed?* Work with a conservator to decide whether or not to treat a previously repaired object. A conservator can give you a variety of options for any project. Old repairs should be removed only if they are unstable or obscuring or damaging surface detail, and if they are not an important part of the history of an object. If a heavily repaired object is stable, there is no reason to remove all the old repairs and redo them. You may want to consider doing cosmetic cleanup and restoration if an object is going on exhibit.
5. *What should I discuss with the conservators before losses are filled?* If there are losses in an object, you will need to discuss with the conservator whether or not they should be filled or replaced. For example, a porcelain vase may have small chips along break lines or even small pieces missing. A stone sculpture may have lost a piece or had it stolen by vandals. Take into account the following before a fill is carried out:
- Is the object stable without the fill?
 - Is the loss unsightly?
 - Do you know what the loss area looked like previously?
 - Do you want the fill to match exactly or only be of similar tone?
 - Are available fill materials stable or will they discolor quickly?
- Different choices will be made based on the stability of the object and aesthetic desires. In general, fine and decorative art objects are restored to a higher level than archeological objects.
6. *When are objects consolidated?* Conservators consolidate objects when they have lost cohesiveness in their structure. Examples of objects that might require consolidation include:
- delaminating glass
 - ceramics that have been seriously damaged by soluble salts
 - stone with a flaking surface
- Different consolidants are used for different materials and for different problems. A conservator will evaluate the problem and recommend a specific material and a specific technique for application that will stabilize your object.

I. Packing and Shipping Glass, Ceramic, and Stone Objects

See Chapter 6: Handling, Packing, and Shipping Museum Objects, for general guidance on packing and shipping objects. Since ceramic, glass, and stone objects are all brittle, sufficient padding must be provided to cushion the object from any shock. Always use double boxing when packing and shipping these objects.

1. *How should I pack ceramic, glass and stone objects for shipping?*

In order to ensure that ceramic, glass, and stone objects are protected, they should be packed in individually contoured foam wells. Polyurethane is a good shock absorber, but it is an unstable material. Polyethylene foam is stable, but cut edges are very abrasive. When you use either foam for padding you must isolate the object from the foam with soft tissue or washed cotton flannel. Don't use buffered paper as it can be slightly abrasive to gilded or painted surfaces.

Objects with extremely delicate surfaces and appendages require special attention. Wrap long strips of soft tissue closely around the object to protect the surface. Fit unsupported areas (for example, handles and spouts) with soft tissue prior to overall wrapping. See Figure P.3 for an illustration of the technique to use for wrapping fragile objects. See Figure P.4 for an example of using layers of foam to completely surround, protect, and pad the object.

2. *How will I ship particularly heavy items?*

Heavy items like stone sculpture will require specially designed cases with interior supports at weight bearing and stabilizing locations. Pad all interior braces. Build in a pallet base so the object can be lifted with a forklift.

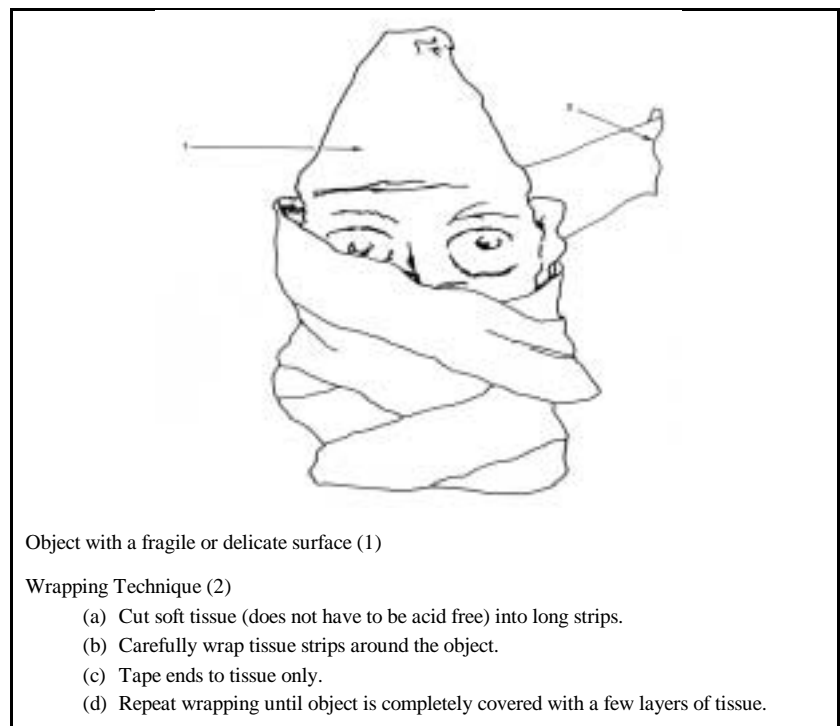

Figure P.3. Technique for Wrapping a Fragile Object

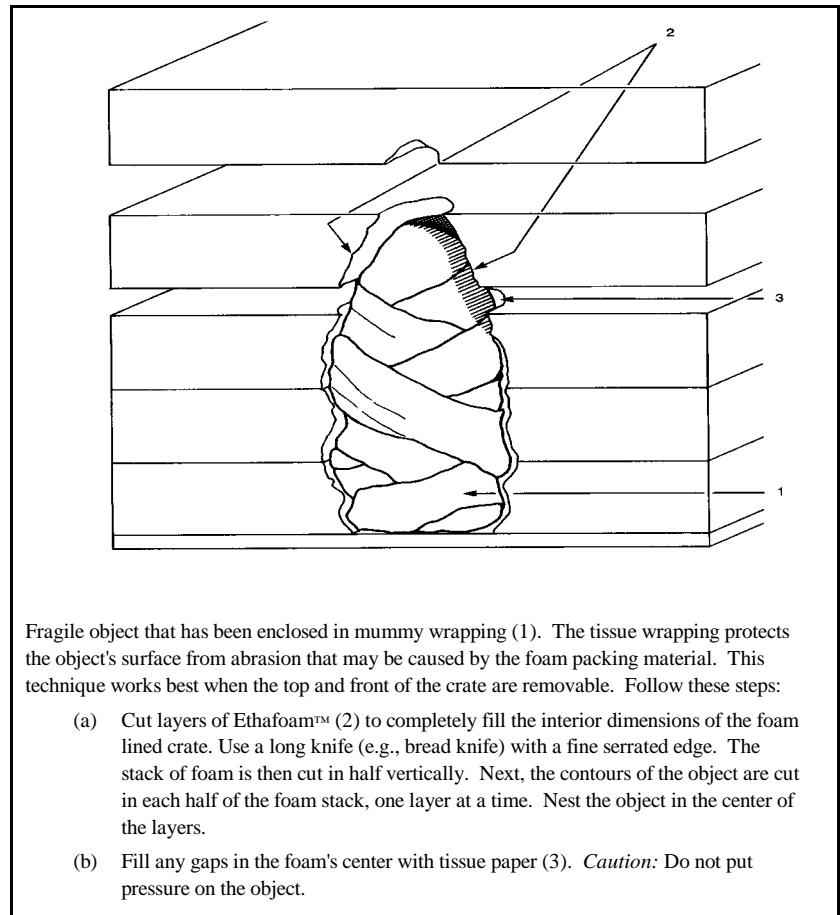

Figure P.4. Layered Foam Packing for Fragile Objects

J. Emergency Procedures for Ceramic, Glass, and Stone Objects

See Chapter 10: Emergency Planning, for general information on planning for emergencies and responding to disasters.

1. *What special procedures should I follow for ceramic, glass, and stone objects after a disaster?*

The following procedures give some specific actions you can take to help preserve ceramic, glass, and stone objects immediately after a disaster.

- **Water:** If water is dripping onto objects, immediately cover them with plastic sheeting or bags. Water can cause stains and streaks. In particular, protect painted pieces, unfired clay, or deteriorated stone or glass. Don't seal the plastic completely as mold may grow.
- **Severe weather:** Move objects away from windows. Cover glass cases or tape the glass to prevent shattering and flying glass. Lay tall objects on their sides and pad so they cannot roll.

- **Liquid attack** (for example, acids, bases, or solvents): Vandals may throw or spill chemicals onto objects that are not protected by cases. Avoid contact with unknown liquids, but act quickly and try to identify the substance. Consult a conservator as quickly as possible to get advice and ensure that damage has been contained.

Small, localized attacks should be rinsed well with water. Water will neutralize acids or bases and slow severe etching.

2. *How do I recover from a disaster with ceramic, glass, and stone objects?*

Air-dry wet ceramic glass and stone objects. If they don't have a damaged or rough surface, you can blot the surface gently with a soft cloth to remove excess water.

If an object is broken, keep people away from it. Photograph it *in situ* if possible. Keep all pieces together, carefully collecting them and placing them in a padded tray or box. Small pieces can be put in plastic bags. Collect even tiny chips. Don't try to fit broken pieces together as this will only abrade edges and prevent a good fit when the object is repaired. Don't allow pieces to rub together. Keep pieces clean; protect them from dust.

Contact a conservator to have the object repaired as soon as possible.

K. Selected Bibliography

General

Hodges, Henry. *Artifacts: An Introduction to Early Materials and Technology*. 3rd rev. ed. London: Duckworth, 1989.

Raphael, Toby. *Exhibit Conservation Guidelines: Incorporating Conservation into Exhibit Planning, Design and Fabrication*. CD-ROM. Harpers Ferry, W.V.: National Park Service, Division of Conservation, 1999.

Rose, Carolyn L., Catharine A. Hawks, Hugh H. Genoways, eds. *Storage of Natural History Collections: A Preventive Conservation Approach*. Iowa City, Iowa: Society for the Preservation of Natural History Collections, 1995.

Ceramics

Cohen, David Harris, and Catherine Hess. *Looking at European Ceramics*. Malibu, Calif.: J. Paul Getty Museum, 1993.

Hamer, Frank, and Janet Hamer. *A Potter's Dictionary of Materials and Techniques*. 2nd ed. London: A & C Black, 1986.

Hodges, Henry W. M. "Problems and Ethics of the Restoration of Pottery." *Stockholm Conference on Conservation in Archaeology and the Applied Arts*. London: International Institute for Conservation, 1975.

Rhodes, Daniel. *Clay and Glazes for the Potter*. Rev. ed., Radnor, Pa.: Chilton Book Co., 1973.

_____. *Stoneware and Porcelain*. Philadelphia: Chilton Book Co., 1959.

Storch, Paul. "Curatorial Care and Handling of Ceramic Objects." *Conservation Notes* 15, Austin, Texas: Texas Memorial Museum, 1986.

Glass

Brill, Robert H. "The Use of Equilibrated Silica Gel for the Protection of Glass with Incipient Crizzling." *Journal of Glass Studies* 20 (1978): 100-118.

Newman, Harold. *An Illustrated Dictionary of Glass*. London: Thames and Hudson, 1977.

Newton, Roy, and Sandra Davison. *Conservation of Glass*. Boston, Mass.: Butterworths, 1989.

Phillips, Phoebe, ed. *The Encyclopedia of Glass*. New York: Crown Publisher, Inc., 1981.

Reilly, Julie A., and Martin Mortimer. "The Care and Conservation of Glass Chandeliers." *Journal of the American Institute for Conservation* 27 (1998): 149-72.

Zerwick, Chloe. *A Short History of Glass*. Corning, N.Y.: Corning Museum of Glass, 1980.

Stone

Amoroso, Giovanni G. *Stone decay and Conservation: Atmospheric Pollution, Cleaning, Consolidation, and Protection*. New York: Elsevier, 1983.

Rich, Jack C. *The Materials and Methods of Sculpture*. New York: Oxford University Press, 1947.

Stambolov, T. "Conservation of Stone." In *Conservation of Stone and Wooden Objects*. Preprints of the Contributions to the International Institute for Conservation New York Conference, 119-123. London: IIC, 1970.

Torraca, G. *Porous Building Materials*. Rome: International Center for the Study of the Preservation and Restoration of Cultural Property (ICCROM), 1981.

Winkler, E. M. *Stone: Properties, Durability in Man's Environment*. 2nd rev. ed. New York: Springer-Verlag, 1975.

Appendix Q: Curatorial Care of Natural History Collections

A. Overview	Q:1
What information is in this appendix?.....	Q:1
Why are natural history collections important?.....	Q:1
What is the purpose in preserving natural history collections?.....	Q:2
What is preventive conservation?.....	Q:2
How can I find the latest information on the care of these natural history collections?.....	Q:3
What other NPS documents give me information about natural history collections?.....	Q:4
Where can I find information about the hazards found in natural history collections?.....	Q:4
B. The Nature of the Collections	Q:5
What is preparation?.....	Q:5
Are there standards for preparation?.....	Q:5
What kinds of natural history materials are particularly important?.....	Q:6
C. Natural History Collections	Q:7
What kinds of specimens will I find in biological collections?.....	Q:7
What groups of species will I find in botanical collections?.....	Q:8
What kinds of specimens and preparations will I find in botanical collections?.....	Q:8
What groups of species are in entomological collections?.....	Q:9
What kind of specimens and preparations will I find in entomological collections?.....	Q:9
What groups of species will I find in other invertebrate collections?.....	Q:10
What kind of specimens and preparations will I find in collections of other invertebrates?.....	Q:10
What groups of species will I find in vertebrate collections?.....	Q:10
What kinds of specimens and preparations will I find in vertebrate collections?.....	Q:10
What groups of specimens will I find in geology collections?.....	Q:12
What kind of specimens and preparations will I find in geological collections?.....	Q:13
How are geological specimens stored?.....	Q:13
What groups of specimens will I find in paleontological collections?.....	Q:14
What kinds of specimens and preparations will I find in paleontological collections?.....	Q:14
How are paleontological specimens stored in collections?.....	Q:14
What kinds of materials are in environmental research collections?.....	Q:15
What kind of specimens and preparations will I find in environmental research collections?.....	Q:15
What kinds of documentation are associated with a natural history collection?.....	Q:15
D. Collecting and Preparation Techniques	Q:16
What are preparation techniques?.....	Q:16
What documentation should I keep on preparation techniques?.....	Q:17
How do collectors prepare dry botanical specimens?.....	Q:18
What problems might I see with dry botanical specimens?.....	Q:19
How do collectors prepare dry entomological specimens?.....	Q:19
What problems might I see with entomological specimens?.....	Q:20
How do collectors prepare dry invertebrates?.....	Q:21
How do collectors prepare dry vertebrate skins?.....	Q:21
What problems might I see with traditional mounting techniques?.....	Q:22
How do collectors prepare skeletal material?.....	Q:22
What problems may arise with skeletal material?.....	Q:23
How do collectors prepare freeze-dried specimens?.....	Q:23
What problems might I see with freeze-dried specimens?.....	Q:23
How do collectors prepare fluid-preserved specimens?.....	Q:24
What problems may occur with fluid-preserved specimens?.....	Q:24

E. Labels and Labeling	Q:25
What types of inks should I use on labels?	Q:25
What preservation problems will I have with metal labels and tags?	Q:26
What kinds of paper labels are used in collections?	Q:26
What kinds of paper labels has NPS used in the past?	Q:26
F. Glossary	Q:27
G. Selected References	Q:29

Appendix Q: Curatorial Care of Natural History Collections

A. Overview

1. *What information is in this appendix?*

Many parks have Scope of Collections Statements that call for collecting and documenting natural history specimens from the ecosystems in parks. This appendix is a brief introduction to the care of a wide range of specimens found in natural history collections. It contains information about:

- the preventive conservation approach for natural history collections in general
- basic descriptions of the variety of specimens you may find in your natural history collections
- descriptions of the common collecting techniques that have historically been used for natural history specimens

Note: Refer to the glossary at the end of this appendix for the definitions of specific terms.

This appendix will **not** give you information on proper techniques for care and storage of natural history collections. Information on preventive conservation for each type of collection will be contained in Appendix T: Care of Biological Collections, Appendix U: Care of Geological and Paleontological Collections, and Appendix V: Care of Environmental Research Collections, to follow. These appendices will give you information on environmental standards, handling, storage techniques, and shipping natural history collections.

Also, this appendix will **not** tell you how to collect and mount specimens yourself. These are skills requiring specialized education and training.

Preventive conservation is the best approach to caring for the vast amount of scientific data resident in natural history collections. Understanding basic collecting and preparation techniques will help you to understand preservation problems specific to natural history collections.

2. *Why are natural history collections important?*

Natural history collections form the basis for our understanding of the world. Scientists use natural history collections to look at questions of evolution and global change. As non-renewable resources, natural history collections document disappearing habitats, species extinction, and disappearing geological and paleontological sites. Natural history specimens document the presence of a species at a specific place and time.

Research enhances the value of these collections. A vast number of questions can be asked about our parks and the environment using natural history collections. As collections are studied and used, the information generated expands our knowledge of the parks and their relation to the broader environment. Collections that have been used for research can be used to document work, confirm conclusions, and develop new interpretations.

3. *What is the purpose in preserving natural history collections?*

Curators and collection managers maintain natural history specimens so scientists can access these specimens in the future to answer questions about the natural world. Collections document change in the natural world. Each properly documented specimen is a unique historical and scientific record. Each natural history collection may be valuable for scientific research.

Preserving the information contained in specimens is the primary goal of natural history conservation.

Preserve each specimen so that scientists can use it to:

- verify past research
- complement or facilitate current research
- encourage and enhance new research in the future

Use preventive conservation to care for scientific collections and maintain them for research by scientists. Focusing on the research potential of these collections doesn't mean that you can't use them for exhibition or teaching. However, you should first consider the research potential of any specimen when making a decision about its care and use. Research on natural history collections is as diverse as the specimens themselves. Review the importance of NPS collection-based research in Chapter 1: NPS Museums and Collections.

4. *What is preventive conservation?*

A specimen with an unknown collection, preparation, and treatment history cannot be used with confidence for any research. A preventive conservation approach ensures the integrity of the specimens for research by introducing as little change as possible. Preventive conservation also improves specimen potential for use in exhibits and educational programming. For an introduction to preventive conservation, see Chapter 3: Preservation: Getting Started. For a discussion of "minimal intervention," see Chapter 8: Conservation Treatment.

A preventive conservation approach allows access to all collections while minimizing the risk of deterioration and loss. Use this perspective while collecting, preparing, and maintaining specimens. Follow the maxim: "minimal intervention – maximum documentation."

Do as little as possible to a specimen and record whatever you do completely and accurately. Record this information in:

- field notes
- ANCS+
 - preparation/treatment supplemental record
 - preservation supplemental record

Good documentation distinguishes conservation treatment from simple meddling. The documentation requirements for any conservation treatment are discussed in Chapter 8: Conservation Treatment, and the American Institute for Conservation (AIC) Code of Ethics and Guidelines for Practice in Appendix D.

Good storage design promotes preventive conservation. Effective storage designs improve access, minimize unnecessary handling, and properly cushion and support specimens. Good storage protects specimens from agents of deterioration, such as pests, light, improper or fluctuating temperature and relative humidity, and environmental pollutants. Use storage materials that will not interact with the specimens. For more information on safe storage materials see the *Conserve O Gram (COG)* series and *NPS Tools of the Trade*.

Active treatments should rarely be performed on a specimen preserved for research. By simply cleaning a specimen you may remove information. Stabilize damaged specimens by means other than active repairs. In contrast, specimens intended for exhibits and educational programming may require repairs for both stability and aesthetics. Repair may be acceptable when it will improve the durability and visual appearance of a specimen for the public.

5. *How can I find the latest information on the care of these natural history collections?*

You can find information on natural history conservation in a variety of sources. Because this is a new and rapidly evolving field, it's important to be aware of new information as it is published.

Sources of information:

- NPS *COG* series includes a section titled "National History Specimens." Watch for updated information.
- The Society for the Preservation of Natural History Collections (SPNHC), a professional organization, specifically supports collections management and preventive conservation for natural history collections. The organization publishes a newsletter and a journal, *Collection Forum*, with information on preservation of natural history collections. SPNHC has published two books that are invaluable resources for any park with natural history collections: *Storage of Natural History Collections: Ideas and Practical Solutions*, edited by Carolyn L. Rose and Amparo R. de Torres and *Storage of Natural History Collections: A Preventive Conservation Approach*, edited by Carolyn L. Rose, Catharine A. Hawks, and Hugh H. Genoways. You can find more information about SPNHC at <<http://www.geo.ucalgary.ca/spnhc/>>.
- Many natural history disciplines support professional groups that publish specialized newsletters and journals with articles on new research and techniques. See Section F for some of these publications.
- Information on the use of natural history collections can be found in *Museum Handbook*, Part III, (MH-III) Chapter 1, Section F.

6. *What other NPS documents give me information about natural history collections?* There are a variety of NPS sources that contain policy and guidance on natural history collections. You should acquaint yourself with the information in the following documents:
- Chapter 1: Museum Collections, and Chapter 2: Scope of Museum Collections, discuss what kinds of collections (including natural history) you should collect and why.
 - Chapter 4: Museum Collections Environment, and Chapter 7: Museum Collections Storage, discuss the building envelope and how it can protect your collections.
 - Museum Handbook, Part II (*MH-II*), Chapter 4: Special Instructions, discusses compliance with the Code of Federal Regulations (36 CFR 2.5). This regulation states the conditions under which the superintendent may issue permits to collect natural history specimens. See especially Section VI, Complying with Regulations for Cataloging Natural History Specimens.
 - *MH-II*, Appendix H: Natural History, describes cataloging and labeling natural history specimens.
 - *MH-III*, Museum Collections Use, discusses research use on existing collections. In particular, see Chapter 1: Evaluating and Documenting Use, Section F, Scientific Issues.
 - Special Directive 91-4, Ensuring that Natural Resource Projects Fund the Curation of Collections, provides guidance on cataloging requirements for collectors. A new *Director's Order #24: Museum Collections Management*, will replace this special directive.
 - New guidance on research and collecting permits, application procedures and related forms has been published in the Federal Register.
 - *Director's Order #28: Cultural Resource Management Guideline*, Chapter 9, Management of Museum Objects, discusses the importance of field notes and other archival and manuscript collections that may help document and interpret museum collections.
7. *Where can I find information about the hazards found in natural history collections?* Information about hazards found in natural history collections is abundant. Hazards come from preparation, storage materials, pest control methods, or may be inherent in the specimens. To find information about hazards, look at:
- references listed under Health and Safety in Section G, Selected References
 - Chapter 11: Curatorial Health and Safety
 - NPS *COG* leaflets on a range of topics, especially Section 2, Security, Fire and Curatorial Safety, and Section 11, Natural History Specimens
 - the Internet, starting with Conservation OnLine (CoOL) <<http://palimpsest.stanford.edu>>, which has a section on health and safety.

B. The Nature of the Collections

The specimens in natural history collections are often diverse and complex. Natural history collections may be:

- organic (such as birds and mammals)
- inorganic (such as rocks and minerals)
- organic/inorganic composites (such as shells, some fossils, and bone)

Specimens are collected from a vast array of natural environments. The one thing most natural history specimens have in common is that they are usually *prepared* before being added to the collection.

1. *What is preparation?*

Most specimens come to museums through field collecting. But, whatever their source, all specimens undergo some field and/or laboratory preparation prior to becoming part of a collection. Preparation may entail the skilled excavation of fragile fossils from the surrounding matrix, or the complex chemical fixation of biological tissues to stop putrefaction. Whatever the preparation method, the reason collectors prepare specimens is to make them accessible for research and other use.

Research and other specimen use vary considerably depending on the collector. Research questions have changed historically. For these reasons specimens of the same kind (for example, bird study skins) may have been prepared by a variety of methods.

For biological collections, most basic preparation is done in the field within hours of the collection of the specimen. This ensures that they will not deteriorate before being taken to the laboratory for final preparation, analysis, and storage. Geological and paleontological collections are prepared both in the field and in the laboratory depending on the particular collecting environment and the needs of the specimen.

After preparation, a specimen may consist of several parts. For example, a small mammal specimen may become a study skin and a separately cleaned and stored skull, while the remainder of the body may be stored in fluid. A matrix formed of various rocks and other minerals may surround a mineral specimen. Parts of the mineral specimen or its matrix may be prepared as separate specimens or as mounts for microscopic examination. You should be aware of the importance of diverse kinds of preparation techniques in natural history collections.

2. *Are there standards for preparation?*

There are no standards for preparation that apply to all specimens. The type of preparation depends on a variety of factors including:

- the kind of specimen
- intended research or other use of the specimen
- skill, experience, and research interest of the collector

- tradition
- available resources

In addition, there has been little research into the chemical and physical effects of many types of preparation. Because of all these issues it is impossible to develop a servicewide standard for preparation of an individual species. **There is no one right way.**

You can work with researchers during the permitting process to request that they use preferred techniques for your collections. See *NPS-77: Natural Resources Management Guideline*, Chapter 5, Program Administration and Management. For example, you can request that a collector use standard-sized glass jars with polypropylene lids lined with polyethylene for vertebrate specimens preserved in fluid. Be aware, however, that certain research issues may require that the scientists use different preparation techniques.

The natural history collection appendices following this one discuss the storage and care issues involved in the long-term preservation of natural science collections. You can use these requirements to help develop preferred preparation techniques for your collections.

3. *What kinds of natural history materials are particularly important?*

There are two kinds of materials that are especially important:

- **Type specimens** are the most important specimens in natural history collections. There are many categories of type specimens. The most important are the name-bearing types. **Taxonomy** is the discipline devoted to the identification, naming, and classification of organisms. Biological specimens are divided into scientific categories called **taxa** (singular taxon) and given specifically defined names (known as nomenclature codes). The biological sciences use Latin names rooted in the classification system begun in the 18th century by Carl von Linne (Linnaeus). Mineralogy uses a system evolved from the 19th century work of James and Edward Dana. Researchers in both the geological and biological sciences use the concept of the “type.”

Type specimens must be designated in the first published description of the taxon. These are the specimens that are designated as the bearers of the scientific name of a taxon. Name-bearing types serve as international standards of reference in taxonomy. Scientists examine type specimens to verify identifications and to revise taxonomic classifications.

The **holotype** is the most important name-bearing type. A holotype is the single specimen that is designated as the type in the first published account of a newly described taxonomic group. The account must be published in an appropriately reviewed scientific book or journal. There are a variety of other name-bearing types that are defined by the different scientific disciplines.

Museums hold type specimens in trust to ensure their safekeeping, and equally importantly, their accessibility for research. **Type specimens are considered to be the property or heritage of the scientific community.** The scientific community considers it unethical for institutions to keep type specimens if they cannot adequately manage and preserve them.

- **Documentation** that accompanies scientific collections is as important as the specimens themselves. You should be sure to gather all documentation and data from the collector and incorporate it in museum collections along with the specimens. Section C discusses the wide variety of documentation that can be important to natural history collections. Labels or tags attached directly to specimens should be considered part of the specimens. Refer to Section E for more information on the care of labels and tags.

C. Natural History Collections

This section briefly lists and describes the variety of materials in natural history collections. It also briefly describes how collectors prepare and store specimens of different materials. The types of collections are broadly divided into four groups:

- biological collections
- geological collections
- paleontological collections
- environmental research collections

Specimens also have scientific documentation that is part of the park's archival collections.

1. What kinds of specimens will I find in biological collections?

Biological collections contain a wide variety of once-living specimens. Park biological collections document local ecosystems and their changes through time. This historical documentation is important to evaluate the effects of park policies on the natural environment. These specimens are divided in a variety of ways, which may vary from collection to collection. For example, invertebrates are separated between entomological (insect) collections and other invertebrate collections (such as mollusks or crabs).

The main divisions are:

- botanical specimens (plants)
- entomological specimens (insects)
- other invertebrate specimens (species with no backbone or spinal column)
- vertebrate specimens (species with a backbone or spinal column)

Examples of the types of specimens found in each of these types of collections appear below.

Microorganisms (bacteria, yeast, protozoa, viruses, diatoms, etc.) may be collected in parks, but are rarely, if ever, deposited in park collections at this

time. They have very specific and technical care requirements that require specialized repositories. For more information on biological specimens, contact specific discipline specialists and refer to *MH-II*, Appendix H: Natural History.

2. *What groups of species will I find in botanical collections?*

Botanical collections contain a wide range of material. The more common groups are:

- bacteria
- algae
- mosses and liverworts
- clubmosses
- horsetails
- ferns
- conifers and other evergreens
- flowering plants
- fungi

See the *MH-II*, Appendix H: Natural History, for a complete list.

3. *What kinds of specimens and preparations will I find in botanical collections?*

Botanical specimens have been collected and stored in diverse ways. Variations depend mostly on the physical characteristics of the specimens but also on their intended use. These include:

- dried plants on herbaria sheets
- dried specimens, or partial specimens, or dissected parts in packets (fragment folders) sometimes attached to herbaria sheets
- lichens and mosses, dried and stored in folded paper or glassine packets and sometimes attached to herbaria sheets or stored in boxes
- dried specimens in boxes – large fungi, wood samples, pine cones, and generally anything dry that is too large for a packet and too bulky for a herbarium sheet
- specimens in fluid – often cacti and other succulents, or flowering plants, fruits, or other specimens where pressing would be difficult or desiccation would destroy tissues of interest, including diatoms, slime molds, fungi, algae, and phytoplankton
- wood samples
- seeds (sometimes in cold storage)
- pollen

- economic botany collections – agricultural seeds, cultivars that are dry or in fluid, plant products
- freeze-dried display specimens
- plant models – display or teaching models in a variety of materials
- living collections
- DNA/RNA extracts
- various microscopy preparations – stained tissues, scanning electron microscope (SEM) stubs or mounts

4. *What groups of species are in entomological collections?*

Park entomological collections contain invertebrates such as insects and arachnids.

- arachnids – mites, scorpions, spiders, ticks
- insects – ants, beetles, bedbugs, bees, butterflies and moths, cicadas, cockroaches, crickets, damselflies, dragonflies, earwigs, fireflies, flies, gnats, grasshoppers, leafhoppers, lice, mantids, mosquitoes, termites, wasps, water boatmen, and weevils, etc.

This is an incomplete list. See *MH-II*, Appendix H, for a more complete list of entomology specimens.

5. *What kind of specimens and preparations will I find in entomological collections?*

You will find entomological collections as:

- pinned specimens – including spread-wing specimens
- specimens on points – specimens mounted on paper or other materials attached to pins
- specimens in fluid – usually alcohol or formaldehyde
- specimens in envelopes or folded packets
- microscopy preparations
- eggs, egg cases, and cocoons (wet or dry)
- larvae and pupae (wet or dry)
- nests
- living entomology specimens (to study life cycles)
- economic entomology collections – species that inhibit or foster agriculture or health, pest species, products from insects

- cultural or art objects derived from insects that are cataloged under cultural resources and cross-referenced to park entomological collections —for example, a necklace decorated with an amber-trapped insect
6. *What groups of species will I find in other invertebrate collections?* Invertebrates are animals without backbones or spinal columns. Entomological collections in parks are usually separated from the other invertebrate collections. These other collections have specimens from both land and water (terrestrial and aquatic) environments.
- brachiopods, corals, crustaceans – for example, lobsters – and a few other classes from the phylum Arthropoda
 - echinoderms – for example, sea urchins
 - mollusks – for example, snails
 - sponges
 - worms
7. *What kind of specimens and preparations will I find in collections of other invertebrates?* Invertebrate specimens may be stored as:
- dry specimens – mollusk shells, corals, most echinoderms, exoskeletons of some crustaceans
 - specimens in fluid – mollusks with or without shells, brachiopods, crustaceans, plankton, sponges, worms
 - specimens or specimen parts as microscopy preparations – mounts from Scanning Electron Microscope (SEM) preparations, mounts on microscope slides, sections of shells
 - shell art and craft objects that are cataloged under cultural resources and cross-referenced to park invertebrate collections
8. *What groups of species will I find in vertebrate collections?* Vertebrates are animals with spinal columns or backbones. Vertebrate collections often include:
- amphibians – for example, frogs
 - birds
 - fishes
 - mammals
 - reptiles – for example, snakes
9. *What kinds of specimens and preparations will I find in vertebrate collections?* Vertebrate specimens may be stored as:
- study skins – untanned skins filled with fibrous materials to approximate the shape of an animal; may contain some skeletal material

- flat skins – tanned or untanned
- taxidermy specimens
 - mounted skins – tanned or untanned skins on mannequins, positioned in a life-like manner; may also contain some skeletal material
 - trophy heads – mounted tanned or untanned skins, sometimes with horns or antlers
- spread wings of birds – dried, untanned, with bones in wings
- naturally mummified specimens
- freeze-dried specimens – complete specimens, or gutted specimens with some fibrous fillings
- fluid-preserved specimens – whole or partial specimens including embryos, larval fish, and some eggs; also includes cleared and stained specimens, such as specimens that have been chemically prepared to be transparent
- skulls
- post-cranial skeletons – articulated, partially articulated, and artificially articulated
- whole skeletons
- dissected parts preserved dry
 - bacula (the penis bone)
 - sectioned teeth
 - stomach contents
 - otoliths (a layered calcium concretion found in the inner ear)
 - hyoids (a bone or a structure formed from cartilage located at the base of the tongue)
 - scutes (plates or shells from armadillos, turtles, tortoises)
- frozen whole specimens – incoming material awaiting processing
- frozen tissues – usually organs preserved for molecular analysis
- scats (dried fecal material)
- regurgitated pellets

- casts, molds, and peels
 - teeth
 - skulls
 - marine mammals
 - fish
 - some reptiles and amphibians
 - animal tracks
- whole eggshells and fragments – bird, mammal, or reptile
- nests – bird, mammal, or reptile
- feathers
- various microscopy preparations
 - SEM mounting stubs
 - tissue sections
 - parasites – both internal and external
- tissues for DNA/RNA extraction
- DNA/RNA, nucleic and amino acids, and other materials extracted from tissues
- feather art (objects crafted from feathers, where the feathers are of interest to scientists)
- animal skin rugs or other objects where the skins are of interest to scientists

10. *What groups of specimens will I find in geology collections?*

Geology collections document geological processes and materials. They can be divided in the following overlapping material types:

- rocks
- surface process materials
- minerals
- organic materials

- extraterrestrial materials
- soils

11. *What kind of specimens and preparations will I find in geological collections?*

Geological collections often contain:

- minerals
- biominerals – amber, pearls, and other materials considered to be minerals that are derived from biological process, such as those in bone and shell
- synthetic minerals
- gems
- rocks
- powders
- drill cores
- frozen specimens – samples of ice or ice cores
- ore samples
- mining concentrates
- soil samples
- products from industrial minerals
- petrology specimens
- meteorites and other materials of extraterrestrial origin
- fossils – collected for mineral content
- various microscopy preparations – thin sections, micromounts, X-ray diffraction mounts, SEM mounting stubs
- jewelry and lapidary art that are cataloged under cultural resources but cross-referenced to park geology collections

12. *How are geological specimens stored?*

Most geological specimens are preserved dry and in a normal oxygen environment. A few minerals require desiccated environments. Some minerals are stored in fluids. Meteorites and other extraterrestrial samples are preserved in specialized gaseous environments. Some radioactive specimens may require specialized housings. There are also a number of light sensitive specimens that should be stored in the dark at all times. For more information on storage and housing of geological specimens, see *COG 11/2*, “Storage Concerns for Geological Collections,” and Appendix U: Paleontological and Geological Collections.

13. *What groups of specimens will I find in paleontological collections?* When considering paleontology collections, most people think of dinosaurs. However, a wide range of plants, insects, invertebrates, and vertebrates will be found in paleontological collections. All ancient biological organisms may be fossilized or preserved in some other manner. For a complete list of paleontology specimens see *MH-II*, Appendix H: Natural History, Paleontology.
14. *What kinds of specimens and preparations will I find in paleontological collections?* Paleontological collections may include:
- frozen specimens – collected from permafrost areas
 - mummified specimens
 - vertebrate and invertebrate body fossils
 - plant and seed fossils
 - trace fossils
 - vertebrate and invertebrate sub-fossil specimens (specimens still retaining organic material)
 - compression fossils (organic remains flattened by the pressure of soil and rock above)
 - mounted skeletons
 - reproductions made for study or exhibits – casts, molds, peels
 - palynology specimens (pollen)
 - specimens in fluid – for example, microfossils in glycerin
 - fossils sliced into sections
 - specimens in jackets (field material still encased in the plaster or other materials used to protect them during shipping to the museum)
 - soil samples – often intended for processing to remove small fossils
 - amino acids, DNA, and other materials extracted from specimens
15. *How are paleontological specimens stored in collections?* Most paleontology specimens are preserved dry, in a normal oxygen environment. Paleontological specimens are often removed from the field in plaster jackets. Before and after preparation, these specimens are stored on shelves or in cabinets. Some microfossils are stored in glycerin or other fluids. Be aware of any radioactive paleontological specimens and use cabinets vented to the outside to store these materials. See *COG 2/5*, “Fossil Vertebrates as Radon Source: Health Update.”

16. *What kinds of materials are in environmental research collections?*

Environmental research collections are specimens, samples, and analytical data collected to monitor levels of various elements and compounds in the environment. Environmental research may result in composite samples, such as water, precipitation, air, and sediment. They are classified separately from biology, geology, and paleontology collections because they are often mixtures of materials collected to study specific environments. For example, a water sample may be collected to study biota.

Some of the specimens and samples require extremely rigorous collecting, storage, and handling procedures to ensure specimen integrity for trace element or other analyses. For example, the National Institute of Standards and Technology, in conjunction with the National Oceanic and Atmospheric Administration and the National Marine Fisheries Service, has developed the National Marine Analytical Quality Assurance Program. Part of this program includes specimen banking (storage of specimens under very controlled, known conditions) to permit analysis of changes in marine environments over time.

17. *What kind of specimens and preparations will I find in environmental research collections?*

The variety of materials you may find in environmental research collections includes:

- biological tissues (in ultra-cold storage)
- soil samples
- water samples
- air samples
- air or water filters
- recording charts from analytical instruments – air, noise, water quality
- eggshell and mollusk shell samples
- other specimens or specimen parts collected according to special protocols

Chapter 2: Scope of Museum Collections, discusses environmental research samples in your scope of collection statement. For a discussion of how these specimens should be cataloged see *MH-II*, Appendix H: Natural History.

18. *What kinds of documentation are associated with a natural history collection?*

In some collections, the documentation is considered to be part of the specimen. Color images made when the specimen was collected are especially important. The National Park Service catalogs these collections as archival collections. The variety of materials used in documenting specimens include:

- original catalogs
- field notes
- locality maps (with handwritten notations)

- card files on various topics
- sampling/dissection records
- charts and graphs produced by analytical instruments
- computer tapes/disks
- original sketches/drawings/watercolors or other paintings
- plates or prints
- photographic records – slides or transparencies, prints, negatives, X-radiographs, prints and negatives of X-ray diffraction patterns and autoradiographs, motion picture film, videotapes, CD-ROMs
- sound recordings – reel-to-reel tapes, cassette tapes, phonograph records, compact disks

Other official records associated with natural history collections include:

- permit files and accession and catalog records (including catalog folders with copies of detached specimen labels)
- loan files
- condition records
- offprints of research articles based on the specimens
- exhibit catalogs featuring specimens
- books and periodicals

D. Collecting and Preparation Techniques.

1. *What are preparation techniques?*

Collectors use preparation techniques to prepare specimens for research and storage. These methods focus on the short-term preservation of the specimen. Preparation techniques achieve a particular purpose for research or public programming use of the specimen. Unfortunately, little research has been done to understand how interactions between the specimen and preservative chemicals or other preparation methods affect long-term preservation. Therefore, few preparation methods can be said to be either “right” or “wrong.” The effects of preparation and storage techniques are areas of active research. Keep abreast of current literature to be aware of changes in methods. Recommendations may change rapidly.

Literally hundreds of chemical formulas, materials, and techniques have been applied to specimen preparation over the past three centuries. Collectors still use many of these techniques. The methods vary according to:

- the kind of specimen – bird, mammal, fish, amphibian, reptile, plant, mineral, fossil
- the primary purpose for which the specimen is collected – research, education, exhibit
- the specific research purpose for which the specimen is collected – gross anatomy, histology, classical taxonomy, biochemical analysis, crystallography, trace element analysis
- the skill and preference of the collector or preparator
- project budget and staff resources

Talk to discipline-specific researchers to gain an understanding of the preparation techniques commonly used on the specimens in your collection. The information given below describes the most common preparation methods. This overview may assist you in requesting adequate data when you accession new collections. The methods are divided into sections on dry collections, freeze-dried specimens, fluid-preserved materials, specimen labels, and labeling techniques.

2. *What documentation should I keep on preparation techniques?*

You should acquire information on the collecting and preparation techniques used for each specimen. Get this information at the same time the park accepts the specimens for the museum collection. The 1988 article by Gerald R. Fitzgerald, “Documentation Guidelines for the Preparation and Conservation of Paleontological and Geological Specimens,” and the 1989 article by Kimball Garrett, “Documentation Guidelines for the Preparation and Conservation of Biological Specimens,” provide excellent surveys of the topics of importance. In addition to information on the condition of the specimens at the time of treatment, these guidelines recommend that you obtain documentation on:

- field collecting and shipping techniques – Was the specimen captured (trapping, netting, killing methods) or salvaged (roadkill)? If it is a fossil or mineral, what were the excavation, packing, and transport methods?
- initial treatments – cleaning, freezing, drying, pressing, fixation, coating or application of other preservatives, jacketing materials, and delayed shipments of frozen material
- initial laboratory treatments on arrival at a museum or other collecting institution
- post-collection treatments of specimens – fumigation, degreasing, fluid changes, cleaning, matrix removal, consolidation, coatings, filling gaps, pest-proofing, restoration, repair
- specimen analyses – X-radiography, dissection, molding and casting, sampling, or other procedures that are likely to have an impact on specimen condition

Record this information in ANCS+ in the Preparation/Treatment associated module.

When specimens deteriorate, there is no way to evaluate the impact of their preparation history on that deterioration unless there is documentation on preparation methods. Hundreds of references on preparation methods have been published. However, there are few records that link a specific treatment to a specific specimen. This void in the documentation of specimens limits their utility for research, exhibition, and educational programs.

A scientist must know how a specimen was treated to decide if it is appropriate for current research. For example, scientists may choose not to do biochemical analysis if a specimen has an unknown history. Also, be careful about using a specimen with an unknown history for open display or in hands-on educational programming. Many long-lived toxic chemicals have been used in specimen preparation and in subsequent treatments of specimens for various purposes.

3. *How do collectors prepare dry botanical specimens?*

Collectors use a variety of techniques to prepare botanical specimens. You may find a range of methods in your older collections. Appendix T: Care of Biological Specimens, describes current NPS standards for collecting and storage. Often, specimens are just collected and pressed. Collectors may kill botanical specimens with a fluid – alcohol or petroleum. These fluids also help to remove water from the specimen. Specimens may also be cut open, boiled or salted, or dried/preserved with alcohol or alcohol vapor prior to pressing. It was common in the past to treat nearly every specimen with chemicals to control insects and microorganisms. Today, collectors more often use heat treatments or freezing.

Specimens to be mounted on herbaria sheets are sometimes washed in the field. To dry and flatten the specimen the collector puts it under pressure between sheets of paper, sometimes with heat. Back at the museum, a preparator mounts pressed specimens on paper or, if the specimen is bulky, on board. If you mount herbarium specimens, buffered, acid-free paper or board should be used. Mounting methods include:

- using strips of cloth, polyester film, or paper attached with adhesive
- using strips made with heat set tissues (a pure cellulose lens tissue impregnated with a heat setting adhesive)
- using adhesive alone, either under the specimen, or as straps
- sewing the specimen to the paper or board with thread

Many materials for mounting herbarium specimens are listed in NPS *Tools of the Trade*.

Packets of paper or glassine are used to store some specimens. Samples that collectors may place in packets and attach to sheets include: microscopy samples, dissected parts, seeds, some fruits, delicate parts of some ferns, and some other easily damaged specimen parts. Microscope slides and photographs are often placed in packets on sheets. Collectors attach labels and packets of fragments with a variety of adhesives.

Collectors sometimes dry bryophytes (mosses, liverworts, hornworts) and fungi with gentle heat. They may cut up fungi to speed drying. In humid field conditions the collector may store fungi and bryophytes over a desiccant chemical (such as calcium chloride) after drying. Fungi are particularly susceptible to insects. They are usually treated with a fumigant or are frozen or heated prior to introduction into a collection. In contrast, bryophytes are not particularly attractive to insects. Pest control chemicals can damage bryophytes. Therefore, collectors keep these specimens as dry as possible and don't contaminate them with fumigants.

Collectors usually store fungi and bryophytes in packets. Fungi packets rarely are attached to sheets; bryophytes are usually attached to sheets. Bulky fungi may require storage in boxes. Fragile species may require small boxes or trays inside the packet.

Some large or bulky botanical specimens are housed in polyethylene bags after drying. Bags, containing various parts of the same specimen, are supported on a mat board the size of a standard herbarium sheet. The entire assemblage is then placed inside another polyethylene bag. Very large specimens may simply be housed in a polyethylene bag. Specimens stored in this fashion must be very dry to avoid fungal growth in the bags. Large palm fronds and conifer branches are candidates for this type of storage.

4. *What problems might I see with dry botanical specimens?*

There are a variety of problems you may see in dry botanical specimens:

- Fragments may be lost from fragile specimens.
- Damage may occur from poor handling techniques and storage.
- Adhesives used by collectors may become acidic, discolor, fail, or shrink, causing damage to the specimens or labels.
- Paper and glassine used for packets may be acidic or may become acidic over time.
- Mold growth may occur on acidic, deteriorating glassine, which tends to be hygroscopic.
- Mold growth may occur on improperly dried specimens.
- Insects may damage the specimens.
- Migration of pesticides may stain herbarium sheets.

Many specimens have been treated with chemicals that may be health hazards or cause damage to the specimen. (See *COG* leaflets 3/12-3/14 concerning problems caused by the use of a variety of fumigants.)

5. *How do collectors prepare dry entomological specimens?*

Collectors use a variety of techniques to prepare entomological specimens. You may find a range of methods in your older collections. Appendix T: Care of Biological Specimens describes NPS standards for curatorial care.

Collectors kill entomological specimens with a chemical vapor or by dropping them in alcohol. They pin small specimens immediately. Other specimens are stored in alcohol or triangular glassine or paper packets.

Sometimes collectors relax specimens in a high humidity chamber (with a chemical to control mold) before spreading and mounting them.

Normally, collectors pin specimens through the right side with stainless steel or coated metal pins. The exact pin placement is governed by the position of the segment at the base of the wings. Sometimes collectors will mount them by first adhering the specimen to a paper or plastic point. Poor quality paper, archival paper, and Mylar or acetate films have all been used as points. Thin, dried strips of fungus, *Polyporus*, have also been used.

Collectors use a variety of adhesives to attach specimens to points. The points are then mounted on pins. Labels are commonly pinned below the specimen using the same pin. Collectors will often dry pinned specimens with low heat in an oven. Specimens removed from fluid may be dried in a critical point dryer. The technique involves dehydrating the specimen in acetone, placing it in a chamber filled with acetone, pumping liquid carbon dioxide into the chamber to replace the acetone, then heating the chamber to the critical point at which the liquid carbon dioxide becomes a gas. With moderate additional heat, the specimen dries completely.

6. *What problems might I see with entomological specimens?*

There are a variety of problems you may see in dry entomological specimens. These include:

- Virtually all specimens are exposed to fumigants or other chemicals at some stage in shipping and/or preparation. Some of these materials remain toxic indefinitely. Today, entomologists most commonly use paradichlorobenzene. You may see crystals of paradichlorobenzene and naphthalene on the specimens or in specimen containers. Because of health and safety concerns about toxicity, this and any other fumigant you use must be approved through your IPM coordinator. See Chapter 5: Biological Infestations.
- Pins with slippery surfaces can yield specimens that “spin,” or turn on the pin.
- Old specimen pins often contain copper or nickel in the alloys. These metals can react with fatty acids in the specimens to produce fibrous blue or green corrosion products.
- The collector may have used unstable papers, films, or adhesives when attaching insects to points.
- Unmounted specimens in paper or glassine packets are often vulnerable to insect pests because they are not yet enclosed in the tightly sealed, glass topped boxes (such as the Cornell-style drawers available through *NPS Tools of the Trade*) that are used to house most pinned insects.
- Damage may be caused by poor storage and handling practices. Sometimes broken body parts will be glued onto a label.

Refer to Appendix T: Care of Biological Collections, for information on preventive care of entomological collections.

7. *How do collectors prepare dry invertebrates?*

Some invertebrates are simply dried. Collectors may also immerse invertebrates in formaldehyde, alcohol, or other solutions. These techniques either kill the animal or work as fixatives. Calcareous materials (shells, corals, echinoderm spines) immersed in formaldehyde and improperly rinsed may be prone to “Byne’s Disease.” This is a mineral efflorescence that results from the reaction of organic acids, such as formic and acetic acids, with a calcium-based substrate. Byne’s Disease usually gives a white powdery appearance to the surface of specimens.

Refer to Appendix T: Care of Biological Collections, for information on preventive care of invertebrate collections.

8. *How do collectors prepare dry vertebrate skins?*

Collectors routinely preserve birds and mammals as dry study skins. In contrast, dry skins of fish, reptiles, and amphibians rarely are preserved in research collections. To prepare study skins, collectors remove the skin from the specimen, treat it with absorbents, and fill it with fibrous materials. The filling is usually cotton batting (although a great many plant fibers and fine sawdust were used in the past). Modern collectors sometimes use polyester batting. Preparators use thin wooden supports inside bird specimens. In mammals, preparators use various types of wire to support the legs and tail. Labels are attached to the hind leg of the specimen with cotton or linen thread. In the past, specimens often were treated with chemicals during their processing. This is less common today, although collectors often rinse mammal skins in alcohol as part of the preparation process, and many collectors use sawdust, cornmeal, or other absorbent materials to facilitate drying. Study skins may be dried with heat. Today, birds sometimes are shipped in dry ice, stored in freezers, and prepared in museums. Collectors usually prepare mammals and birds in the field.

Collectors may dry large flat skins of vertebrates in the field, salt the skins, and later stabilize them using a variety of tanning processes. Sometimes collectors prepare the skins of small vertebrates as untanned flat skins. In this process, they remove the skin from the animal and then pin it to dry in a flat position. They may use absorbents in the skinning process and rinse small skins in alcohol prior to drying.

Taxidermy mounts and trophy heads can be extremely complex. A taxidermist may mount virtually any vertebrate. Taxidermists sometimes tan skins, but often they simply place a skin in a chemical solution to soften it. Once it is flexible enough, they manipulate it over a mannequin and let it dry in place. Mannequins may be bundles of fibrous materials, or a hard body constructed of plaster, fiberglass, or other easily formed materials. An internal armature of wood or metal supports the mannequin. Leg bones, or other skeletal material, and the skull may be used in the mounts. Other techniques used in mounting specimens include freeze-drying (see below).

Sometimes vertebrate shells or plates (scutes) and reptile and amphibian skins are dried and kept in collections. This is no longer a common practice and specimens prepared this way in the past were often treated with pest control chemicals during processing. Scutes are especially likely to have been treated with long-lived toxic materials. In some cases, the skins may have been tanned. Most often, they were prepared as untanned flat skins or were stuffed with any of a variety of fibrous materials.

9. *What problems might I see with traditional mounting techniques?*

There are a variety of problems you might see in specimens prepared using traditional mounting techniques:

- Arsenic and a number of other toxic compounds were used in the preparation and post-preparation treatment of taxidermy specimens. See *COG 2/3*, "Arsenic Health and Safety Update," for information on handling and use of these specimens. Commercial taxidermists may regard their materials and processes as proprietary and often are reluctant to provide detailed information. Tanned skins are rarely

treated with pest control chemicals because the tanning processes render the skins fairly unattractive to insects and reasonably resistant to mold.

- Study skins of vertebrates with long tails and mammal specimens prepared with ears in upright positions are vulnerable to mechanical damage during storage and handling.
- Metal support wires used in specimens may corrode over time. Because the corrosion products have a greater volume than the original metal, the corrosion process often tears the skins. Metal armature in taxidermy mounts and wires in study skins may be copper or nickel alloys that will produce fibrous, blue or green corrosion products when they react with the fats in skins.
- The skins on taxidermy mounts are under great stress because the skins often shrink tightly to the form during drying. As a consequence, removing mounted specimens from their original stand changes the distribution of the stress, often causing the skins to tear or distort.

Refer to Appendix T: Care of Biological Collections, for information on preventive care of vertebrate collections.

10. *How do collectors prepare skeletal material?*

- Collectors may remove skulls and skeletons from specimens when fresh, after freezing, and occasionally from fluid-preserved specimens. They first remove much of the flesh from the bone. They then clean the specimens using a variety of techniques including:

- enzyme solutions
- maceration (with and without heat, detergents, ammonia, or bleaches)
- burial in sand, soil, or manure
- dermestid beetle colonies

After any of these treatments, further rinsing and some hand cleaning may be necessary. If cleaned by beetles, the specimens usually are fumigated, frozen, or rinsed in alcohol to kill the insects. Then the bones may be soaked in ammonia or chlorine bleach solutions to deodorize. The resulting specimens are then dried (with or without heat). Bones from large animals like bears may be degreased using organic solvents or alcohol. Sometimes large long bones are drilled and the marrow is removed to reduce the potential for migration of fats and oils out of the bone.

Fish skeletons may be removed from frozen specimens and cleaned with enzymes. Sometimes preparators stain the bones with an organic dye and store them in glycerin solutions.

11. *What problems may arise with skeletal material?*

Bone and teeth frequently deteriorate in vertebrate collections. Therefore, try to get documentation on exactly what processes preparators have used on bone. Bone is an organic/inorganic composite material. This means that the organic components are intimately mixed with the inorganic components and help to reinforce them and give them a certain flexibility. There are a variety of problems you might see in skeletal specimens.

- Prolonged maceration, enzyme solutions that have not been properly neutralized, and ammonia and chlorine bleach solutions that have a high pH degrade proteins, the primary organic reinforcement in bone and teeth, leaving the specimens brittle.
- Heat may also denature the protein.
- Acidic solutions attack the inorganic part of the composite, leaving bones soft and easily distorted.
- Poor storage and handling can damage bone causing cracking, abrasion and breakage. Low humidity in storage environments will cause cracking, especially to teeth.
- Numbers that have been written directly on the bone with indelible ink cannot be removed.

Refer to Appendix T: Care of Biological Collections, for information on care of skeletal material.

12. *How do collectors prepare freeze-dried specimens?*

Almost all types of biological specimens have been freeze-dried for exhibit purposes. After the specimens are frozen, the water is removed from them using vacuum sublimation. Specimens may be treated with a variety of chemicals as preparation for freeze-drying. After processing, preparators may use other materials to enhance specimen appearance. Large animals are difficult to freeze-dry, so these are often eviscerated before freezing. After freeze-drying, the specimens are stuffed with fibrous materials.

13. *What problems might I see with freeze-dried specimens?*

The loss of bound water makes freeze-dried specimens extremely fragile. For an excellent review of the problems of freeze-dried specimens see, "The Effects of Freezing and Freeze-drying on Natural History Specimens," by Florian (1990) listed in the Section G, Selected References. Because freeze-dried specimens are vulnerable to rehydration, especially at relative humidity above 40%, they can rot. It is important that you keep them in dry environments. Freeze-dried specimens are especially attractive to insect pests. Place these specimens in tightly sealed cabinets to prevent pests from getting into exhibit and storage cases.

Freeze-dried specimens are often used in NPS exhibits. These specimens are extremely vulnerable to insect attack and may be damaged or destroyed, requiring replacement. If you have freeze-dried specimens on display be sure to use good Integrated Pest Management (IPM) strategies to protect them. See Chapter 5: Biological Infestations, for information on developing an IPM plan.

Refer to Appendix T: Care of Biological Collections, for information on care of freeze-dried specimens.

14. *How do collectors prepare fluid-preserved specimens?*

A fluid-preserved specimen is “fixed,” that is, treated with a chemical that causes some cross-linking of cell proteins. Then the specimen is stored in either the original fixative or in a chemical that preserves the fixed tissue. Collectors use a wide variety of chemicals for both processes. Sometimes specimens are not fixed prior to placing them in storage solutions.

Often, you will find small to moderately sized fluid-preserved specimens stored in glass bottles or jars. Large specimens are usually stored in tanks made of a variety of plastics or metals. Occasionally, plastic or metal liners are used inside a wooden frame or box. Collectors mount very tiny specimens on microscope slides or in small glass or plastic vials. Sometimes small containers are grouped inside larger glass containers.

In *botanical* collections perhaps the most common fixative is a solution called formal acetic alcohol (FAA). It is a mixture of formaldehyde (formalin), ethanol (ethyl alcohol), and glacial acetic acid in various proportions. A number of other fluid compositions have also been used. Instead of formalin fixatives, some preparators use alcohol as a preservative or a mixture of ethanol (with or without some methanol), water, and glycerin. There are a number of fixative/storage solutions, many of which contain glycerin.

In *entomology* ethanol is the most common fixative and preservative fluid in entomology. Sometimes other chemicals have been added to ethanol in an effort to preserve color or relax specimens.

Vertebrate specimens are usually fixed in buffered formalin and then preserved in alcohol. Numerous alkali neutralizers or actual buffers may be used in the formalin. Ethanol (70%) is the preferred storage fluid for mammals and birds. Fish, reptiles, and amphibians are stored in various concentrations of isopropanol (isopropyl alcohol) or ethanol. Numerous compounds are used for color preservation in vertebrate specimens. Preparators may have added these to any specimen.

15. *What problems may occur with fluid-preserved specimens?*

The container, closure, and gasket may react with the specimens or the fluid. Ask the donor what kinds of containers were used to house the specimens from the time they were collected. The storage solvent will evaporate over time and have to be replaced. Prior to fixation, collectors sometimes freeze specimens. This often leads to poor quality fixation and preservation.

Solvents used to store fluid-preserved specimens may gradually soak out lipids, proteins, and pigment over time, causing the solution to become discolored or cloudy. Labels printed on poor quality paper may deteriorate. The metal closure on flip-top jars may corrode.

Refer to Appendix T: Care of Biological Collections, *COG* 11/3, “Storage Concerns for Fluid-Preserved Collections,” and 11/4, “Storage Containers and Labels for Fluid-Preserved Collections,” for additional information on the care of fluid-preserved specimens.

E. Labels and Labeling

Inquire about the materials a collector used to label specimens. This will give you an indication of the preservation problems that may lie ahead. Labels contain important original information about the specimen and in some cases may be the primary documentation on the object. The information recorded on a label may include:

- species scientific name
- species common name
- collector's name
- collecting location
- habitat
- collection date
- field catalog number
- collecting institution
- park code
- catalog number
- accession number
- original fixative
- preservative

All NPS specimens should have NPS labels. See *MH-II*, Appendix H, for information on labels and labeling. Ordering information is available in NPS *Tools of the Trade*.

1. *What types of inks should I use on labels?*

Good inks for documentation are carbon printing inks, heat-fused carbon toner for printers and photocopiers, and carbon-based drafting film ink for technical pens. There are also some pigmented black inks in felt-tip pens that are acceptable for use on labels. Unfortunately, the ink often used on labels or on specimens is a dye that is acidic. It will fade when exposed to light and may fade as a result of exposure to oxygen in the air. Ballpoint pens and fugitive pencil (such as red pencils) will fade and therefore are not acceptable for writing on labels. See Williams and Hawks (1986) and Wood and Williams (1983) for information on inks and pens to use with both dry and fluid-preserved natural science collections. You can order ink and pens for labeling natural history collections through the NPS *Tools of the Trade*.

See more information on recommended inks, pens, and lettering styles and attaching strings and pins in *MH-II*, Appendix H. *COG 11/4*, "Storage Containers and Labels for Fluid-Preserved Collections," also gives information on inks and printers.

2. *What preservation problems will I have with metal labels and tags?*

Preservation problems arise from metal ear tags, bat and bird bands, and the small metal labels that collectors used to apply catalog numbers to some fluid-preserved specimens and skeletal specimens. All these specimens may be subjected to processing or storage in fluids, at which time the labels can begin to corrode.

- Corrosion products can stain specimens and, in some instances, may cause the labels to adhere to the specimens.
- Sharp corners on the labels can tear specimens.
- Metal labels on dry skeletal material scratch and abrade the bone.
- Specimen labels made of pure tin can degrade on frozen specimens.

Though separating the labels from the specimens and storing them is one approach; it is always best to keep labels with the specimens. For bone, you can keep the labels in small polyethylene bags in the container with the specimen, but not attached directly to the bone. In fluids, you can seal the metal ear tags and leg bands in air in small glass vials with polyethylene caps and place them in the container with the specimen. These methods allow the label to remain in the container with the specimen.

3. *What kinds of paper labels are used in collections?*

Paper labels may be made of almost any paper product, many of which are not permanent or durable. The paper may be single-ply or a laminate of two or more layers. Fluid specimen labels are sometimes made of Resistall paper, a cotton rag paper that has been treated with a melamine resin to make it fluid-resistant. Resistall papers often have a fairly low pH (4.5-5.2).

Labels reduced or reproduced by photocopy processes may be alkaline buffered, acid-free paper or may be any type of common photocopy paper. The paper used in printers to generate labels falls into the same categories.

4. *What kinds of paper labels has NPS used in the past?*

Since 1982 the Museum Management Program (MMP) has specified that paper labels be of 100% white rag or alpha cellulose content or be maximum permanence paper (with alkaline filler). The MMP makes these labels available through *Tools of the Trade*. Previously, Lewis, in *Manual for Museums* (1976), specified high quality, liquid-resistant paper. Burns, in *Field Manual for Museums* (1941), recommended white linen tags tied with linen thread for mammal specimens and high quality white paper for insects on pins. Older park collections will probably contain all these types of labels in their collections, as well as other labels that outside collectors used.

You must use NPS supplied labels when tagging specimens. Specify this requirement in collecting permits. When replacing old, non-standard labels be sure to keep the originals.

Refer to *MH-II*, Appendix H, for information on natural history specimen labels and their content.

F. Glossary

Arthropods – any of numerous invertebrate organisms of the phylum Arthropoda, which includes insects, crustaceans, arachnids, and myriapods

Articulated – when parts of a skeleton are joined together for display

Biology – the science of living organisms and life processes

Bolus (boluses) – prehistoric mammoth dung

Botany – the scientific study of plants

Brachiopods – any of various marine invertebrates of the phylum Brachiopoda, having bivalve shells and a pair of tentacled, arm-like structures on either side of the mouth

Bryophyte – a plant of the major botanical division Bryophyta; includes the true mosses, peat mosses, and liverworts

Chitin – a semitransparent horny substance that forms the principal component of crustacean shells, insect exoskeletons, and the cell walls of certain fungi

Consolidation – application of a liquid polymer (glue, plastic) that imparts strength to a fragile specimen

Crustaceans – any of the various predominantly aquatic members of the taxonomic group Crustacea, characteristically having a segmented body, a chitinous exoskeleton, and paired joined limbs; includes lobsters, crabs, shrimps, and barnacles

Duff – insect excrement and shed skins left as waste on specimens; frass

Echinoderms – any of a number of radially symmetrical marine invertebrates of the phylum Echinodermata, having a body often covered with spines; includes starfish, sea urchins, and sea cucumbers

Entomology – the scientific study of animals

Exoskeleton – an external protective or supporting structure of many invertebrates

Fixing – the use of a chemical, often formaldehyde, that reacts with tissue to limit deterioration

Frass – insect excrement and shed skins left as waste on specimens; duff

Herbarium – a collection of plants mounted and labeled for use in scientific study

Holotype – the single specimen used as the basis for the original published description of a taxonomic species

Infills – a gape or hole in a specimen that is filled with a foreign material for structural stability or aesthetic integration

Invertebrate – animal lacking a backbone or spinal column

Maceration – using a liquid to soften and remove flesh

Molding and casting – techniques used by preparators and others to make copies of specimens

Mollusks – any of various members of the phylum Mollusca, largely marine invertebrates; includes edible shellfish

Nomenclature – a system of terms used in a particular science or discipline, for example, an international system of standardized New Latin names used in biology for kinds and groups of animals and plants

Ontogeny – the history of the development of an individual organism

Peel – a specimen produced by applying a polymer to the surface of an object to reproduce surface texture that is then “peeled” off

Phylogeny – the ordering of species into taxa; evolutionary history of a species

Preparation – the process of readying natural science specimens for storage in a museum collection

Scat – excrement, fecal material

Scute – plates or shells from armadillos, turtles, or tortoises

Sublimation – the conversion of a solid directly into a vapor without passing through the liquid state

Systematics – the science of classifying all organisms, living and extinct, and of investigating relationships between them; the field of science concerned with taxonomy and phylogeny

Tanning – methods used to change the chemical structure of skin making it resistant to deterioration

Taxa – plural of taxon

Taxon – a group of organisms that makes up one of the categories in taxonomic classification, such as a phylum, order, family, genus, or species

Treatment – usually refers to a repair or restoration done by a conservator

Type – a specimen or sample used as the basis of description of a species

Vertebrate – animals with segmented bony or cartilagenous spinal columns

Zoology – the biological science of animals

Sources of Glossary Definitions

The American Heritage Dictionary, Second College Edition. Boston: Houghton Mifflin Company, 1976.

Duckworth, Donald W., Hugh H. Genoways, and Carolyn L. Rose. *Preserving Natural Science Collections: Chronicle of Our Environmental Heritage*. Washington, D.C.: National Institute for the Conservation of Cultural Property, 1993.

Uvarov, E. B., and Alan Isaacs. *The Penguin Dictionary of Science*. 6th Ed. London: Penguin Books, 1986.

G. Selected References

The Nature of Natural History Collections

- American Ornithologists' Union. "Report of the *ad hoc* Committee on Scientific and Educational Use of Wild Birds." *Auk*, Supplement (1975): 1A-27A.
- Banks, Richard C., compiler. *Museum Studies and Wildlife Management: Selected Papers*. Washington, D.C.: Smithsonian Institution Press, 1979.
- Biological Survey of Canada. *The Importance of Research Collections of Terrestrial Arthropods: A Brief Prepared by the Biological Survey of Canada*, Supplement to the Bulletin 23. Canada: Entomological Society of Canada, 1991.
- Carter, David, and Annette K. Walker. *The Care and Conservation of Natural History Collections*. Oxford, UK: Butterworth-Heinemann Ltd., 1999.
- Cato, Paisley. "Guidelines for Managing Bird Collections." In *Texas Tech University Museum Museology Series No. 7*. Lubbock: Texas Tech Press, 1986.
- _____. *Natural History Museums: Directions for Growth*. Edited by Clyde Jones. Lubbock: Texas Tech Press, 1991.
- Cohen, Daniel, and Roger Cressey, eds. "Natural History Collections: Past Present and Future" In *Proceedings of the Biological Society of Washington* 82:559-762. Washington, D.C.: Biological Society of Washington, 1969.
- Collins, Chris, ed. *The Care and Conservation of Palaeontological Material*. Oxford, UK: Butterworth-Heinemann Ltd., 1995.
- Committee on North American Resources in Invertebrate Paleontology. *Fossil Invertebrates-Collections in North American Repositories, 1976*. Iowa City: University of Iowa and the Paleontological Society, 1977.
- Committee of the Society of Vertebrate Paleontology on the Status of Fossil Vertebrate Conservation in the United States. *Fossil Vertebrates in the United States*. Society of Vertebrate Paleontology, 1972.
- Conference of Directors of Systematics Collections. "The Great Collections: Their Nature, Importance, Condition, and Future." Part I. *The Systematics Biology Collections of the United States: An Essential Resource*. Washington, D.C.: National Science Foundation and the Conference of Directors of Systematics Collections, 1971.
- Croat, Thomas B., compiler. "Survey of Herbarium Problems." *Taxon* 27 (1987): 203-218.
- Doughty, P. S. "The State and Status of Geology in U.K. Museums," *Miscellaneous Paper No.13*. London: Geological Society and the Geology Curators' Group, 1981.
- Duckworth, Donald, Hugh Genoways, and Carolyn Rose. *Preserving Natural Science Collections: Chronicle of Our Environmental Heritage*. Washington, D.C.: National Institute for the Conservation of Cultural Property, 1993.
- Dunn, P. J. "The Discreditation of Mineral Species: Guidelines Endorsed by the Commission on New Minerals and Mineral Names." *Mineralogical Record* 22 (1992): 91-94.

- Faber, P. L. "The Type Concept in Zoology During the First Half of the Nineteenth Century." *Journal of the History of Biology* 9 (1977): 93-119.
- Frey, J. K., Terry L. Yates, D. W. Duszynski, William L. Gannon, and S. L. Gardiner. "Designation and Curatorial Management of Type Host Specimens (Symbiotypes) for New Parasite Species." *Journal of Parasitology* 78 (1992): 930-932.
- Forman, Leonard, and Diane Bridson. *The Herbarium Handbook*. Kew: Royal Botanic Gardens, 1989.
- Howie, Frank, ed. *The Care and Conservation of Geological Material: Minerals, Rocks, Meteorites and Lunar Fines*. Oxford, UK: Butterworth-Heinemann Ltd., 1992.
- Genoways, Hugh H., Clyde Jones, and Olga L. Rossolimo, eds. *Mammal Collection Management*. Lubbock: Texas Tech Press, 1987.
- Herholdt, Elizabeth, ed. "Natural History Collections: Their Management and Value." *Transvaal Museum Special Publication No. 1*. Pretoria: Transvaal Museum, 1990.
- Hounsome, M. V. "Research: Natural Science Collections." In *A Manual of Curatorship: A Guide to Museum Practice*, 2^d ed., edited by J. M. Thompson, pp. 536-541. Oxford: Butterworth-Heinemann, 1992.
- International Commission on Zoological Nomenclature. *International Code of Zoological Nomenclature*, 3d ed. London: International Trust for Zoological Nomenclature and British Museum (Natural History), 1985.
- Knutson, Lloyd, and William L. Murphy. *Systematics: Relevance, Resources, Services and Management: A Bibliography, Special Publications*. Washington, D.C.: Association of Systematics Collections, 1988.
- Lee, Welton L., Bruce M. Bell, and John F. Sutton. *Guidelines for Acquisition and Management of Biological Specimens*. Lawrence, Kansas: Association of Systematics Collections, 1982.
- Melville, Richard V. *Towards Stability in the Names of Animals: A History of the International Commission on Zoological Nomenclature 1895-1995*. London: International Trust for Zoological Nomenclature, on behalf of the International Commission on Zoological Nomenclature, 1995.
- Miller, Edward H., ed. "Museum Collections: Their Roles and Future in Biological Research." *Occasional Papers Series No. 25*. Province of British Columbia: British Columbia Provincial Museum, 1985.
- Miller, Scott E. "Biological Diversity and the Need to Nurture Systematics Collections." *American Entomologist* 37 (1991): 76.
- _____. "Entomological Collections in the United States and Canada: Current Status and Growing Needs." *American Entomologist* 37 (1991): 77-84.
- Reynolds, Daniel, and J. Taylor. "DNA Specimens and the 'International Code of Botanical Nomenclature.'" *Taxon* 40 (1991): 311-315.
- Simmons, John E. "Herpetological Collecting and Collections Management." *Herpetological Circular No. 16*. Tyler, Texas: Society for the Study of Amphibians and Reptiles, 1987.
- Solem, Alan, William K. Emerson, Barry Roth, and Fred G. Thompson. "Standards for Malacological Collections." *Curator* 24 (1981): 19-28.
- White, J. S. "Some Aspects of Modern Mineral Specimen Curation." *Mineralogical Record* 22 (1991): 251-254.
- Wiktor, J., and R. Wladyslaw. *Bibliography of Catalogues of Type Specimens in World Zoological and Paleozoological Collections*. Wroclaw, Poland: Wroclaw University Press, 1991.

Williams, B. *Biological Collections UK*. London: Museums Associations, 1987.

Wood, R.M., and S. L. Williams. "An Evaluation of Disposable Pens for Permanent Museum Records." *Curator* 36(1993): 189-200

Zorich, Diane, and K. Elaine Hoagland. *Status, Resources, and Needs of Systematics Collections*. Washington, D.C.: Association of Systematics Collections, 1995.

Collecting and Preparation Techniques

Many of the sources cited in the section above also contain information on collecting and preparation methods.

Anderson, Rudolph M. *Methods of Collecting and Preserving Vertebrate Animals, National Museum of Canada Bulletin No. 69, Biological Series No. 18*. Ottawa: National Museum of Canada and the Department of the Secretary of State, 1965.

Burns, Ned J. *Field Manual for Museums*. Washington, D.C.: National Park Service, 1941.

Cannell, Peter, C. S. Asa, and M. R. Bakst. "Suggestions Regarding Alcoholic Bird Collections." *The Condor* 90 (1988): 500-503.

Cumberland, Barbara. "Using Freeze-dried Animal Specimens in Exhibits." *CRM* 22:7 (1999):23-26.

Faber, P. L. "The Development of Taxidermy and the History of Ornithology." *Isis* 68 (1982): 550-556.

Fink, William L., Karsten Hartel, Ellie Koon, William Saul, and Edward Wiley. *A Report on Current Supplies and Practices Used in Curation of Ichthyological Collections*. Washington, D.C.: Ad hoc Subcommittee on Curatorial Supplies and Practices of the American Society of Ichthyologists and Herpetologists Ichthyological Collection Committee, 1979.

Fitzgerald, Gerald R. "Documentation Guidelines for the Preparation and Conservation of Paleontological and Geological Specimens." *Collection Forum* 4 (1988): 38-45.

Garrett, Kimball L. "Documentation Guidelines for the Preparation of Biological Specimens." *Collection Forum* 5 (1989): 47-51.

Hangay, G., and M. Dingley. *Vertebrates*. Vol. 1. Biological Museum Methods. London: Academic Press, 1985.

_____. *Plants, Invertebrates and Techniques*. Vol. 2. Biological Museum Methods. London: Academic Press, 1985.

Harris, R. H. *A Selective Bibliography on Preservation, Macro and Micro-anatomical Techniques in Zoology, Report No. 3*. United Kingdom: Biology Curators' Group, 1984.

Hawks, Catharine, and Stephen Williams. "Arsenic in Natural History Collections." *Leather Conservation News* 2: 1-4.

Hawks, Catharine, and David Von Endt. "Mercury and Mercury Compounds in Natural History Collections: An Annotated Bibliography." *Natural History Conservation* 5 (1990): 4-19.

Hildebrand, Milton. *Anatomical Preparations*. Berkeley and Los Angeles: University of California Press, 1968.

Horie, C. Velson, ed. "Preparation and post-preparation treatment of specimens in fluids." *Conservation of Natural History Specimens: Spirit Collections*. Manchester, England: The Manchester Museum and the University of Manchester, Department of Environmental Biology, 1989.

- _____ and R. G. Murphy. "Preparation and Post-preparation Treatments of Specimens." *Conservation of Natural History Specimens: Vertebrates*. Manchester: The Manchester Museum and the University of Manchester, Department of Environmental Biology, 1988.
- Howie, Frank M. "Materials Used for Conserving Fossil Specimens Since 1930." In *Adhesives and Consolidants*, edited by N. Bromelle, E. Pye, P. Smith, and S. Thomson, London: International Institute for Conservation, 1984.
- _____. "Conserving and Mounting Fossils: A Historical Review." *Curator* 29 (1986): 5-24.
- Lewis, Ralph. *Manual for Museums*. Washington, D.C.: National Park Service, 1976.
- McElman, James F., Kenneth Sulak, and Lou Van Guelpen. "References for the Preparation of Ichthyological Specimens." *Curation Newsletter* 9 (1987): 7-15.
- Nagorsen, David, and Randolph Peterson. *Mammal Collectors' Manual, Life Sciences Miscellaneous Publication*. Toronto: Royal Ontario Museum, 1980.
- Pritchard, Mary Hanson, and Gunther Kruse, compilers. *The Collection and Preservation of Animal Parasites, The Harold W. Manter Laboratory Technical Bulletin No. 1*. Lincoln and London: University of Nebraska Press, 1982.
- Rogers, Stephen P., Thomas Gutebier, and Mary Ann Schmidt, compilers. *An Annotated Bibliography on Preparation, Taxidermy, and Collection Management of Vertebrates with Emphasis on Birds, Special Publication No. 15*. Pittsburgh: The Carnegie Museum of Natural History, 1989.
- Rogers, Stephen P., and D. Scott Wood, compilers. *Notes from a Workshop on Bird Specimen Preparation*, held at The Carnegie Museum of Natural History in Conjunction with the 107th Stated Meeting of the American Ornithologists' Union. Pittsburgh: The Carnegie Museum of Natural History, 1989.
- Rose, Carolyn L., and Amparo R. de Torres, eds. *Storage of Natural History Collections: Ideas and Practical Solutions*, Iowa City, Iowa: Society for the Preservation of Natural History Collections, 1992.
- Carolyn L. Rose, Catharine A. Hawks and Hugh H. Genoways, eds. *Storage of Natural History Collections: A Preventive Conservation Approach*, Iowa City, Iowa: Society for the Preservation of Natural History Collections, 1995.
- Scott, Norman J., and Aida Luz Aquino-Shuster. "The Effects of Freezing on Formalin: Preservation of Specimens of Frogs and Snakes." *Collection Forum* 5 (1989): 41-46.
- Steedman, H. F., ed. *Zooplankton Fixation and Preservation*. Paris: The UNESCO Press, 1976.
- Thomas, Robert A., compiler. "Selected Bibliography of Certain Vertebrate Techniques." *U.S. Department of the Interior, Bureau of Land Management Technical Note No. 306*. Washington, D.C.: U. S. Government Printing Office, 1977.
- Upton, Murray S. "Aqueous Gum-Chloral Slide Mounting Media: An Historical Review." *Bulletin of Entomological Research* 83 (1993): 267-274.
- Wagstaffe, Reginald. *Vertebrates, Botany, and Geology*. Vol. 2: The Preservation of Natural History Specimens. New York: Philosophical Library, 1955-1968.
- _____ and J. Havelock Fidler, eds. and compilers. *Invertebrates*. Vol. 1. The Preservation of Natural History Specimens. New York: Philosophical Library, 1955-1968.

Waller, Robert, and Thomas Strang. "Physical Chemical Properties of Preservative Solutions-I. Ethanol-Water Solutions." *Collection Forum* 12 (1996): 70-85.

Whybrow, Peter. "A History of Fossil Collecting and Preparation Techniques." *Curator* 28 (1985): 5-26.

Williams, Stephen, and Catharine Hawks. "Inks for Documentation in Vertebrate Research Collections." *Curator* 29 (1986): 93-108.

Wood, Rose. "A Note on 'Inks.'" *SPNHC Newsletter* 2 (1988): 1.

_____ and Stephen Williams. "An Evaluation of Disposable Pens for Permanent Museum Records." *Curator* 36 (1993): 189-200.

Yasutake, William T. *Collection and Preparation of Fish Specimens for Histological Examination, Fish and Wildlife Leaflet No. 11*. Washington, D.C.: United States Department of the Interior Fish and Wildlife Service, 1987.

Health and Safety

Goldberg, L. "A History of Pest Control Measure in the Anthropology Collections, National Museum of Natural History, Smithsonian Institution." *Journal of the American Institute for Conservation* 35(1996): 23-43.

Henry, E. E. "The Merckoquant 10026 Arsenic Test for Natural History Collections." *WAAC Newsletter* 18:1 (1996).

Makos, Katherine A., and Elizabeth C. Dietrich. "Health and Environmental Safety." In *Storage of Natural History Collections: A Preventive Conservation Approach*, edited by Hugh H. Genoways, Catharine A. Hawks, and Carolyn L. Rose, pp.233-254, 1995.

Professional Newsletters and Journals

American Mineralogist

Journal of the Mineralogical Society of America
1015 18th Street NW, Suite 601
Washington, DC 20036
<<http://www.minsocam.org/AmMin/ammin.html>>

Association of Systematic Collections (ASC) Newsletter

1725 K Street NW, Suite 601
Washington, DC 20006-1401
Email: asc@ascoll.org.

Biology Curator's Group Newsletter

Biology Curator's Group
The National History Museum
Cromwell Road
London SW7 5BD
UK

Circaea, the Bulletin of the Association for Environmental Archaeology
Professor Don Brothwell, AEA Chair Wendy Carruthers, Newsletter Editor
Department of Archaeology Sawmills House
University of York Castellau
King's Manor Pontyclun
York YO1 2EP Llantrisant CF7 8LP
UK UK
<<http://super3.arcl.ed.ac.uk/aea>>

Collection Forum

Society for the Preservation of Natural History Collections (SPNHC)
Museum of Natural History
Division of Fishes
MRC 159
Washington, DC 20560
<<http://www.geo.ucalgary.ca/spnhc/>>

Conservation News

United Kingdom Institute for Conservation
6 Whitehorse Mews
Westminster Bridge Road
London SE1 8QD
UK

Curator

The Museum Journal
California Academy of Sciences in partnership with AltaMira Press
AltaMira Press c/o Sage Publications
2455 Teller Road
Thousand Oaks, CA 91320
<<http://www.altamirapress.com>>

The Geological Curator

Geological Curator's Group
University of Glasgow
<<http://www.gla.ac.uk/Museum/John/GCG/geolcura.html>>

*Journal of the American Institute for Conservation
of Historic and Artistic Works*

1717 K Street NW, Suite 301
Washington, DC 20006
<<http://palimpsest.stanford.edu/aic/>>

Journal of Evolutionary Biology

Birkhauser Verlag AG
Birkhauser Publishing Ltd.
P.O. Box 250
CH-4105 Biel-Benken
Switzerland
<http://www.birkhauser.ch/journals/3600/3600_aim.htm>

For issues published in 1999 and later:

Blackwell Science, Ltd.
Osney Mead
Oxford, OX2 0EL
UK
<<http://www.blacksci.co.uk/products/journals.htm>>

Journal of Mammology

American Society of Mammologists
H. Duane Smith, Secretary-Treasurer
Monte L. Bean Life Science Museum
Brigham Young University
Provo, UT 84602-0200
<<http://www.wku.edu/~asm/asminfo.html>>

Leather Conservation News
c/o Paul Storch, Editor
Minnesota Historical Society
Conservation Dept.
345 Kellogg Blvd. West
St. Paul, MN 55102-1906

Natural History Conservation
Newsletter of the International Council of Museums (ICOM)
Committee for Conservation
Maison de l'UNESCO
1 Rue Miollis
75732 Paris Cedex 15
France

Nature, International Weekly Journal of Science (Macmillan Publishers)
Nature America Inc. (for North, South, and Central America)
P.O. Box 5055
Brentwood, TN 37024-5055

SPNHC Newsletter
Society for the Preservation of Natural History Collections
Invertebrate Paleontology
Peabody Museum of Natural History
Yale University
170 Whitney Avenue
P.O. Box 208118
New Haven, CT 06520-8118
<<http://www.spnhc.org>>

Taxon,
International Association for Plant Taxonomy
c/o The Botanic Garden and Botanical Museum Berlin – Dahlen (BGBM)
Freie Universität Berlin
Konigin-Luise-Str. 6-8
14191 Berlin
Germany
<<http://www.bgbm.fu-berlin.de/IAPT/Taxon/default.htm>>

Appendix R: Curatorial Care of Photographic Collections

	<u>Page</u>
A. Overview	R:1
What information will I find in this appendix?	R:1
Why is preventive conservation important for these materials?.....	R:1
How can I find the latest information on care of these types of materials?.....	R:1
B. The Nature of Photographic Materials	R:1
What is the component structure of photographic materials?.....	R:1
Why should I identify photographic processes?.....	R:2
What are the basic types of final image materials and how do they deteriorate?.....	R:2
What are the various types of binder layers?.....	R:3
What are examples of primary supports?	R:4
Are there other structural concerns?.....	R:5
C. Preparing a Preservation Strategy	R:6
Why do I need a preservation strategy?	R:6
What are the basic elements of a preservation strategy?.....	R:6
How should I assess and control the environment?	R:6
Should I establish handling procedures and a disaster plan?	R:7
Should I rehouse photographic prints and negatives?.....	R:7
How do I rehouse photographic prints and film negatives?	R:7
How should I preserve color materials?	R:8
How do I evaluate photographic materials for conservation and further preservation?.....	R:9
Who should inspect film-base negatives?.....	R:9
What about reformatting and duplicating deteriorating materials?	R:9
Who should inspect copy images?.....	R:11
D. Preventive Conservation: Handling Photographic Collections	R:12
How do I handle photographic prints?.....	R:12
How do I handle daguerreotypes, ambrotypes, and tintypes: cased and uncased formats?.....	R:13
How do I handle glass plate negatives and transparencies?.....	R:14
How do I handle film-base black-and-white negatives and transparencies?.....	R:14
How do I handle slide collections?	R:15
E. Preventive Conservation: Storing Photographic Collections in the Proper Environment	R:15
How do I store photographic prints?	R:15
How do I store daguerreotypes, ambrotypes, and tintypes: cased and uncased formats?.....	R:16
How do I store glass plate negatives?	R:16
How do I store film-base black-and-white negatives?.....	R:16
How do I store color photographic collections?	R:17
What characteristics do I need to know about color photographic collections?	R:18
F. Preventive Conservation: Housing Photographic Collections	R:19
How do I house photographic prints and negatives?.....	R:19
What about paper photographic storage enclosures?	R:19
What about plastic photographic enclosures?	R:21
How do I house panoramic (oversized) prints?.....	R:23
How do I containerize sleeved prints?	R:23
What storage techniques do I use to rehouse photographic materials?.....	R:23

How do I house daguerreotypes, ambrotypes, and tintypes: cased and uncased formats?	R:24
How do I house glass plate negatives and positives (lantern slides)?.....	R:25
How do I house black-and-white negatives?.....	R:26
Why do I place color photographic collections in cold storage?	R:27
How do I determine what is appropriate cold storage?.....	R:27
What do I need to know about storage in a frost-free refrigerator?	R:27
What do I need to know about storage in a cold storage vault?	R:29
When can I remove original photographic materials from cold storage?.....	R:30
How do I house color slide collections?	R:30
G. Preventive Conservation: Exhibiting Photographic Collections	R:30
How do I exhibit photographic prints?	R:30
How do I exhibit daguerreotypes, ambrotypes, and tintypes: cased and uncased formats?	R:31
How do I exhibit color photographic collections?	R:31
H. Preventive Conservation: Inspecting Photographic Collections	R:33
What is the Condition Checklist for Visual Images?	R:33
How do I use this checklist?	R:33
Where do I find the checklist?	R:33
I. Conservation Treatment Issues for Deteriorated Photographic Materials	R:33
What does this section cover?	R:33
Why use a conservator?.....	R:33
What are the ethical considerations?	R:34
What treatments will the conservator use?	R:37
J. The Recovery of Water-Damaged Photographic Materials	R:41
How should I recover water-damaged materials?.....	R:41
What should I salvage first?	R:41
K. Selected Bibliography	R:42
List of Figures	
Figure R.1. Appropriate Light Levels for Photographic Media	R:7
Figure R.2. Relative Humidity and Temperature Requirements for Photographic Media	R:16
Figure R.3a-b. Condition Checklist for Visual Images (Sample)	R:35

APPENDIX R: CURATORIAL CARE OF PHOTOGRAPHIC COLLECTIONS

A. Overview

1. *What information will I find in this appendix?*

This appendix discusses the composition and physical structure of photographic materials and outlines their long-term care and preservation.

2. *Why is preventive conservation important for these materials?*

All photographic materials are especially vulnerable to deterioration when exposed to:

- inadequate environmental conditions
- improper storage enclosures
- careless handling practices
- damaging exhibition procedures

For this reason, preventive care is absolutely critical to the long-term preservation of these irreplaceable images.

3. *How can I find the latest information on care of these types of materials?*

Watch the following sources for new information and techniques:

- NPS *Conserve O Gram (COG)* series
- e-mail NPS Museum Management Newsletter

See the NPS Museum Handbook, Part I (MH-I), Chapter 3, Museum Objects Preservation: Getting Started, for a discussion of preventive conservation and conservation treatment.

B. The Nature of Photographic Materials

Photographs are images formed by the action of radiation, usually light, upon a sensitized surface. While often thought of as a single technique, photography is many hundreds of related chemical processes known by a wide variety of process and trade names. Sources of assistance for descriptions of the various photographic processes are included in Section K.

1. *What is the component structure of photographic materials?*

The component structure of photographic materials includes a variety of:

- *final image materials*, such as silver
- *binders*, such as albumen, collodion, and gelatin
- *supports*, such as paper, plastic film, metal, or glass (also called the *base*)

Negatives, prints, transparencies, and slides are all photographs.

The laminate structure of prints is often further complicated by the presence of:

- secondary supports
- additional colorants
- coatings
- adhesive layers

2. *Why should I identify photographic processes?*

Identifying the photographic process (final image material, binder, and base) will allow you to accurately assess the relative short- and long-term stability of a specific photographic object.

3. *What are the basic types of final image materials and how do they deteriorate?*

The image in every photograph is created by materials that absorb and scatter light. Final image materials may include:

- photolytic or filamentary silver
- metallic platinum
- pigments
- organic dyes

The final image material in most nineteenth-century photographic prints is a finely divided *metallic silver*, identified as “printed-out” or “photolytic” silver. Photolytic, or metallic, silver particles are rounded in shape and scatter light, and, as a result, produce the red or brown image tones associated with nineteenth-century print materials in good condition. Photolytic silver particles are quite small and are extremely susceptible to image deterioration and rapid loss of highlight detail.

The final image material in most twentieth-century photographic prints is *filamentary silver*, which consists of bundles of intertwined filaments, resembling steel wool, that are huge in comparison to photolytic silver particles. These larger particles are significantly less vulnerable to image deterioration. Their irregular structure absorbs light rather than scatters it. Therefore, filamentary silver images are characterized by a neutral black image color, unless toned with gold, sepia, selenium, or hand-colorant.

All silver images are prone to severe oxidation and, as a result, undergo characteristic changes. Photolytic silver images exhibit general fading throughout, a loss of highlight detail, and a shift in image color toward warmer (more red or yellow) tones. Filamentary silver images, on the other hand, exhibit a significant shift in color from neutral black to yellow brown as they deteriorate.

Mirroring, a dark, mirror-like, reflective tarnish stain caused by oxidation, is a common symptom of deterioration in silver images. It often appears as

a bluish, metallic sheen visible in a photograph's dense image areas when examined in reflected or raking light. Silver images also can be adversely affected by improper processing during manufacture, resulting in a severely yellowed and faded final image material.

In platinum prints, the final image material is *metallic platinum*. Since platinum is a noble metal, it's not susceptible to oxidation. Therefore, platinum images don't tarnish or fade. Platinum is, however, a catalyst for cellulose deterioration. Platinum prints may exhibit an embrittled and discolored primary paper support.

Pigments, such as lamp black, burnt and raw umber, burnt sienna, and Prussian blue, often have been used as final image materials for such printing processes as carbon, gum bichromate, and cyanotype. These pigments usually are dispersed in a binder, such as gelatin, gum arabic, or linseed oil, and tend to have good to excellent overall stability.

Finally, *organic (synthetic) dyes*, as used in most contemporary negative and positive color processes, are considerably less stable, and will fade both in the dark and upon exposure to light. The destruction or decolorization of organic dyestuffs in color photographs is due to irreversible changes in their chemical structure. Upon exposure to light, high humidity, or high temperature conditions, organic dyes are readily converted to oxidized and often colorless dye fragments.

4. *What are the various types of binder layers?*

The binder in photographic material is the transparent layer in which the final image material is suspended and protected. Binders are important in determining optical properties, such as surface smoothness, gloss, density, and color, as well as the overall stability of specific print materials. The binders most commonly used throughout the history of photography include:

- *albumen*, a globular protein from the white of hens' eggs
- *collodion*, a form of cellulose nitrate
- *gelatin*, a highly purified protein commercially produced primarily from animal hides and bones

Albumen (ca 1850-1900) actively deteriorates and yellows due to the inherent characteristics of the egg white protein and its chemistry. Albumen has a strong affinity for silver ions, and as a result, in processing these materials, colorless silver-albuminate complexes may be formed. Upon exposure to reactive sulfiding compounds, these colorless complexes may be converted to a yellow silver sulfide with a resulting increase in overall discoloration or staining leading to yellowing and loss of detail in non-image (highlight) areas. Albumen yellowing also occurs from prolonged exposure to light and high relative humidity conditions.

The albumen binder will expand and contract when exposed to fluctuating environmental conditions. Albumen prints, therefore, characteristically exhibit severely cracked and crazed binder layers. Albumen images almost always are mounted on a secondary support, since unsupported images will

curl into tight rolls.

Collodion (ca 1851-1920) was used as a transparent binder in both glossy- and matte-surfaced photographic printing papers manufactured at the turn of the century as well as for ambrotypes, tintypes and the wet plate negative process that was introduced in 1851. Collodion is brittle, and is easily abraded and mechanically damaged when handled improperly.

Photographic **gelatin** (ca 1870-present) is a highly purified, homogeneous protein. While it is relatively stable and doesn't yellow severely like albumen, it is very reactive to changes in temperature and relative humidity conditions. When exposed to moisture, gelatin swells up to twenty times its volume, becoming soft and tacky. Finally, gelatin can serve as a nutrient for microbiological or fungal activity in conditions of high relative humidity and also is attractive to insects and vermin as a food source.

5. *What are examples of primary supports?*

The most common primary supports used throughout the history of photography include:

- paper
- glass
- flexible film
- sheet metal

In both historic and contemporary photographic print materials, the image-bearing layer usually consists of a coating on a **paper-based** support. When handled improperly, paper supports are susceptible to irreversible mechanical damage in the form of tears, creases, and losses.

In the early days of photography, these paper supports were manufactured from the highest quality rag fiber or chemically purified wood pulp. After 1881, machine-manufactured photographic papers were coated in the factory with a baryta layer, which consisted of the white pigment barium sulfate and gelatin. The baryta layer produced a highly reflective surface, allowing for greater contrast and brilliance in the final print. It also acted as a protective barrier between trace impurities in the primary support and the light-sensitive materials.

Plastic-coated, or resin-coated, photographic papers were introduced in the late 1960s. They were often subject to embrittlement, cracking, and/or localized fading of the photograph's silver image. Within recent years stabilizers have been introduced into these papers. As a result, current plastic-coated papers, when processed correctly, are considered to be as stable as fiber-based supports.

While **glass** was the favored image support material in the nineteenth century, these supports may deteriorate under unfavorable environmental conditions. The chemical composition of support glass is the single most important factor pertaining to the long-term preservation of collodion plates. Deterioration of the glass support can result in softening and flaking of the collodion binder and varnish layers as well as discoloration and

fading of the silver image.

Nearly all existing still and motion picture *films*, prior to the introduction of polyester film in 1955, were produced on a cellulose plastic support. Earlier films were made from cellulose nitrate, first marketed in 1889 and manufactured until 1951. See NPS *MH-I*, Appendix M, Care of Cellulose Nitrate Negatives. Later films were composed of a variety of cellulose acetate supports. All cellulose plastic bases are subject to hydrolysis upon exposure to adverse environmental conditions, particularly high relative humidity. The hydrolysis of cellulose nitrate film, for example, releases nitrous oxide, a strong oxidizing agent that aggressively attacks image silver and severely embrittles the plastic film base as well as all nearby materials. Cellulose nitrate film base also is highly flammable and will burn underwater, as it produces its own oxygen during combustion. Valuable cellulose nitrate negatives must be reformatted and placed in cold storage.

In acetate films, acid hydrolysis won't accelerate silver image deterioration. However, the indirect consequences of hydrolysis may result in massive shrinkage and physical deformation, such as cockling, buckling, and channeling of the film base. Furthermore, acid-catalyzed hydrolysis will cause fire-retardant additives, historically incorporated into the film base during manufacture, to be released and deposited as liquid-filled bubbles in the gelatin binder.

Some of the earliest photographic processes used *metal* as the image's primary support. A daguerreotype photograph, for example, is a silver-plated sheet of copper with the whites or highlights of the image being a silver-mercury-gold amalgam and the darks pure silver metal. The daguerreotype plate is susceptible to deterioration resulting in the formation of corrosion films, primarily silver sulfide, on the support's surface. Tintypes were manufactured on japanned iron plates. The japanned surface was usually composed of a mixture of raw linseed oil, asphaltum, and lamp black pigment. A tintype's iron support may corrode or rust at the plate's unvarnished edges or anywhere the protective japanned surface has been scratched or otherwise damaged. Corrosion of the iron support may result in irreversible flaking and/or loss of a tintype's image-bearing (collodion) layer.

6. *Are there other structural concerns?*

Yes. When you analyze the component structure of photographic materials, you will also need to evaluate the presence or absence of a secondary support, hand colorants, final coatings (waxes, gelatin, and spirit varnishes such as shellac) and adhesive layers. Photographic prints often have been hand-colored with a variety of media, sometimes fugitive, including watercolors, pastels, and aniline dyes. These additional components can strongly influence the final appearance and stability of all photographic materials. Rubber cement adhesives, for example, can irreversibly stain and yellow binder layers.

C. Preparing a Preservation Strategy

A general understanding of the nature of photographic materials provides a basis for developing a preservation strategy for the collection.

1. *Why do I need a preservation strategy?*

A preservation strategy will help you care for and protect these diversified collections. In establishing a preservation plan, you need to understand and consider many issues pertaining to format and type, condition, housing, value, access, and use. In determining value, for example, you need to ensure that the collection materials support the park's approved Scope of Collection Statement and that these photographs are important for their artifactual, evidential, associational, administrative, or informational value. For example, heavily-used collections of lower value may be granted higher preservation priority when compared with little-used materials of higher value. See *COG 19/10, Reformatting for Preservation and Access: Prioritizing Materials for Duplication*.

Photographic collections should be assessed by a conservator for condition, processes, and format. The conservator should carefully examine all types of items in the collections, including albums, scrapbooks, and newer items such as microforms. Owing to quantity, it is often difficult, if not impossible, to examine all photographic objects in a collection; however, boxes and groups of items can be randomly sampled and assessed for storage, treatment, handling, and exhibition needs. In doing so, the conservator may make a checklist for tracking and quantifying general condition and deterioration problems associated with various photographic items. See Section H for a condition checklist.

2. *What are the basic elements of a preservation strategy?*

A preservation strategy tells you how to do the following:

- monitor, assess and control the environment
- establish handling procedures and a disaster plan
- rehouse photographic images
- reformat color materials and preserve originals in cold storage, where appropriate
- evaluate photographic materials for conservation treatment
- inspect negatives
- duplicate deteriorating materials
- inspect copy images

3. *How should I assess and control the environment?*

Survey storage facilities and exhibition spaces for evidence of the potentially damaging environmental conditions of relative humidity, temperature, light, and pests.

- Maintain the relative humidity (RH) levels for most photographic materials at 20% to 40%. You should strive for this range when

storing all types of photos in one area. However, if you are storing only film-base materials, the preferred range is at 20% to 30% RH.

- Store most color and film-base collections at 4.4°C (40°F) or below. When you place collections in cold storage, they should remain in cold storage as much as possible. Therefore, make copy negatives and prints available for duplication and research use.
- Monitor and control the environmental conditions, especially relative humidity, in collections storage and exhibits to reduce the potential for microorganism growth. When RH reaches 65% and temperature rises above 75°F, the potential for microorganism growth increases.
- Use the photographs at the appropriate light levels. See Figure R.1.

Century	Type of Photograph	Appropriate Light Levels
19th	Most 19th century processes	<50 Lux or 5 footcandles
Late 19th (1880s)-20th	Photographs with Baryta Layers, such as Gelatin Printing-Out Paper, Collodion Printing-Out Paper, and Gelatin Developing-Out Paper	<100 Lux or 10 footcandles
20th	Modern color photographs	<50-100 Lux or 5-10 footcandles

Figure R.1. Appropriate Light Levels for Photographic Media

4. *Should I establish handling procedures and a disaster plan?*

Yes! First, establish handling and preservation procedures that are oriented toward stabilizing the condition of the entire collection.

Then, ensure that these procedures are followed so that the level of preservation is consistent throughout the collection.

Finally, establish a disaster plan to protect the museum collections in an emergency.

5. *Should I rehouse photographic prints and negatives?*

If the photographic prints are in acid-free or acid-neutral housings, you don't need to rehouse them, unless the housing is damaged. In all other situations, you need to rehouse photographic materials in acid-free archival sleeves and folders.

6. *How do I rehouse photographic prints and film negatives?*

If you need to rehouse *photographic prints*:

- place each print in archival-quality plastic or paper enclosures to prevent damage from chemical deterioration and improper handling
- place the enclosure containing prints in a box or drawer
- place boxes or drawers on shelves or in cabinets

If you need to rehouse *glass plate negatives* and stabilize them:

- place negatives in four-fold archival paper enclosures
- place negatives upright on their long edge in padded boxes
- place boxes on shelves
- label boxes "Fragile Glass"

If you need to rehouse *photographic albums and scrapbooks*:

- box them to protect them from dirt, dust, and gaseous pollutants
- interleave photograph albums with neutral pH tissue

Don't use buffered tissue or acid-free paper.

- don't use interleaving materials if they will cause stress on album bindings (such as significantly swelling a volume's width)

If you need to rehouse *daguerreotypes, ambrotypes, and tintypes*:

- house them in acid-free folding boxes
- identify actively deteriorating cover glasses and replace them with contemporary high-grade alumina silicate glass
- have a trained conservator supervise the uncasing and resealing operations

If you need to rehouse *film-based negatives*:

- place each negative in a sleeve
- place each sleeved negative in a box or drawer
- place each box or drawer on a shelf or in cabinet

7. *How should I preserve color materials?*

After housing, place color photographic materials in refrigeration or cold storage to slow irreversible deterioration. Cold storage promotes a longer life for the photographs being preserved. Even 20°F below room temperature provides many decades of additional life for photographic materials. Store collections of color negatives, transparencies, and prints, in archival housing within Ziplock bags in boxes, in a frost-free refrigerator with low-humidity refrigeration. You may place humidity indicator strips within the bag to help monitor environmental conditions.

If you must remove materials from the cold storage vault, for example if the power has been out for longer than 48 hours, allow the materials to acclimatize at room temperature for several hours before handling them.

Don't forget to monitor the frost-free refrigerator for temperature and humidity levels and to establish retrieval and access guidelines to severely limit the removal of materials.

8. *How do I evaluate photographic materials for conservation and further preservation?*

You should work with a conservator to learn how to identify photographic processes and formats and deterioration characteristics. Check photographic materials for:

- active flaking or powdering
- mold growth
- tape or adhesives present
- severely deteriorated supports

Ensure that photographic materials with these conditions receive conservation treatment.

9. *Who should inspect film-base negatives?*

You should work with a conservator to:

- inspect film-base negative collections and evaluate them for deterioration
- establish duplication programs
- develop handling guidelines
- establish archival storage procedures

10. *What about reformatting and duplicating deteriorating materials?*

You won't always be able to preserve all photographs in pristine condition. When faced with massive deteriorating photographic holdings, you will need to strike a balance between stabilization, treatment, and duplication.

Some processes, such as cellulose acetate and cellulose nitrate negatives may totally self-destruct over time in a normal storage environment. The self-destructive images are said to have inherent fault or inherent vice. The only way to preserve cellulose nitrate and cellulose acetate negatives may be permanent cold storage. In order to save the informational content of these negatives, it is necessary to duplicate these images using more stable materials. See *MH-I*, Appendix M, Care of Cellulose Nitrate Film, and *COGs* 19/10 through 19/13 on preservation reformatting.

Other photographic materials, while not as prone to self-destruction as cellulose acetate or cellulose nitrate, will deteriorate as a result of use, such as exhibition, regular handling, or frequent duplication. These heavily used materials will also benefit from duplication, as the duplicates may become the copies for use while the originals are preserved in cold storage.

Some scholarly researchers may still need to view the originals in order to study the image's process, format, or technique. In most cases, researchers

are interested in the informational value of an image. Informational values may be captured in high-quality photographic copies.

If you need to rehouse and/or duplicate film-base collections, carefully consider the following options:

- ***Interpositives.*** For maximum quality control during duplication, you should produce an interpositive (intermediate positive image on clear film). Make this interpositive from the original negative by contact printing the image onto a sheet of clear film, producing a positive transparency. Then, make a laterally correct (not reversed) copy negative from the interpositive. Retain the interpositive to serve as an archival master used for the creation of additional copy negatives. Use the copy negative as the duplication master to produce copy prints for staff and researchers. Keep the original negative in cold storage.
- ***Direct Reversal Film.*** Another procedure requires the use of direct reversal film, to produce a direct but laterally reversed duplicate negative. The resolution of direct-duplicating film is good, although tone reproduction can be poor. Because of their fine-grained structure these films are prone to oxidation leading to silvering out and mirroring, hence image detail loss. These images must be accurately processed and toned during use and carefully inspected and tested after creation. Such requirements make the actual cost of direct duplicates equivalent to interpositive processes without providing the same quality of images. Request either polysulfide toning or gold toning which will extend the life of the negative. Be aware that gold toning can add 20-50% to the cost. In many cases, direct reversal or direct duplicate images, also known as direct positive images, don't produce publication quality negatives.

Selenium toner was frequently recommended for use with all copy negatives, particularly direct duplicate negatives. However, the Image Permanence Institute (IPI) in Rochester, New York has found that selenium may not adequately protect a filamentary silver image in low density regions from oxidative attack. Don't request selenium toning of photographs. IPI is currently investigating the use of a polysulfide toner to which a small percentage of borax is added. For additional information, contact the Image Permanence Institute, Rochester Institute of Technology, 70 Lomb Memorial Drive, Rochester, NY 14623-5604, 716-475-5199.

- ***Copy prints and camera negatives or long-roll camera film.*** Other duplication options to consider include producing of copy prints and camera negatives from the original negative or using a long-roll camera film for efficient and cost-effective duplication of large collections. As with direct reversal film, these processes won't necessarily produce publication or exhibition quality copies and some of the images' informational value may be lost.

When you are faced with massive deteriorating film holdings, consult a conservator. See *COG 19/10, Reformatting for Preservation and Access: Prioritizing Materials for Duplication*. You should carefully evaluate the

available duplication options discussed above and consider the following factors:

- collection's size
- informational value
- evidential value
- associational value
- administrative value
- artifactual value
- condition
- projected use
- funding and staffing resources available

Collection value, usage, and risk or stability probably should determine which items you duplicate first. Don't dispose of original negatives once duplicated unless they are in an advanced state of deterioration.

Finally, you should establish two regular inspection programs:

- One should evaluate the technical and archival quality of the duplicate negatives. Compare the duplicate's optical, tonal, and physical characteristics with the originals. See *COG 19/13, Preservation Reformatting: Inspection of Copy Photographs*.
- The other should be used for all deteriorated film holdings. Select envelopes from every drawer at random and examine them for signs of deterioration as mentioned above. Note incipient deterioration so that you can monitor specific materials during the following inspections. Inspect collections with unregulated climates and generally poor conditions as many as four times per year.

11. *Who should inspect copy images?*

You should have all interpositives, negatives, prints, and slides, whether produced internally or by an outside photographic studio, inspected upon return.

All photographic copy work done for preservation purposes should be done to American National Standards Institute (ANSI) standards. Cite these standards in all contracts with photographers. Don't pay for duplication until after the copies pass inspection. Inspect the copy versus the original for: resolution, tonal range, completeness of image, and residual levels of chemicals. Materials that don't pass inspection criteria should be reshot at the photographic laboratory's expense. See Section K for a list of the appropriate standards.

Have someone experienced in reading negatives and in darkroom work, such as a photographer (other than the photographer who did the copy work), inspect all images. Inspection requires experience and a trained eye.

See COG 19/13, Preservation Reformatting: Inspection of Copy Photographs.

D. Preventive Conservation: Handling Photographic Collections

1. *How do I handle
photographic prints?*

All photographic materials, color as well as black-and-white, may be irreversibly damaged by fingerprints, scratches, abrasions, and other forms of mechanical damage or mishandling. Here are some guidelines.

Historic photographic prints may be irreversibly damaged if handled carelessly. The surfaces of these prints are delicate and, therefore, easily scratched, abraded, creased, cracked, or torn.

General guidelines for ensuring object safety during any handling procedure are outlined in *MH-I*, Chapter 6, Handling, Packing, and Shipping Museum Objects. Some basic principles for the safe handling of historic and contemporary photographic print materials are listed below.

- Prepare a clean and uncluttered workspace for the safe handling of photographic collections. Instruct staff and researchers on the proper ways to handle photographs.
- Establish and enforce handling guidelines (for example, restricting food, drink, smoking, the use of pens) for all staff.
- Wear gloves when accessing collections that aren't protected by enclosures and when handling photographs that require temporary removal from paper or plastic sleeves. Research at the National Archives of Canada shows that immediate interactions will occur between salt in human perspiration and a photograph's final image material. These interactions result in irreversible oxidation of image silver to silver chloride followed by image staining or mirroring where the fingers touch the image. Staff and researchers who are required to wear cotton gloves will often approach a photographic collection with additional care and respect.
- Use temporary or permanent auxiliary supports (such as pH neutral board) during handling if necessary. In all instances, handle the auxiliary support and not the object itself.
- Exercise special caution when using plastic sleeves. Clear plastic sleeves are often too flexible to prevent structural damage. Slip a piece of archival bond (neutral pH) behind the image back before placing it in the sleeve. Transcribe any information from the back of the image in pencil to the back of the archival bond.

Removing unmounted photographic prints from their polyester sleeves may prove difficult because of the static charge of the polyester film. Slit the plastic sleeve at a sealed edge and gently separate the cover sheet from the photograph by rolling it away from the object's surface.

- Control access to all collections. Using copy prints and/or xerographic copies will greatly reduce handling and subsequent damage. Restrict

the photocopying of all original materials. In doing so, maintain and use a "master" set of xerographic copies for all subsequent photocopying. See *COG 19/4, Archives: Preservation Through Photocopying*, and *19/7, Archives: Reference Photocopying*. Any collection that is regularly reproduced should have an effective system for creating master negatives so that originals need not be constantly photographed.

- Establish current inventories, finding aids, and container (such as box or folder) lists for all photographic collections to further reduce unnecessary handling.

2. *How do I handle daguerreotypes, ambrotypes, and tintypes: cased and uncased formats?*

You should consider the daguerreotype, ambrotype or tintype and its original housing as a total artifact deserving protection as a whole. Don't disturb these housings unless absolutely necessary. If for any reason you remove an original housing, carefully label and retain them.

If you remove an original housing, use a small suction cup to carefully lift the "photographic package" out of the miniature case interior. This maintains proper configuration and orientation of the fabric liner that serves as a "compression seal" within the case and further protects the photographic image from oxidation. Don't use a suction cup if the brass mat and tape assembly are damaged or not present.

Do not disassemble the photographic package without the supervision of a trained conservator.

Restrict the handling of all original material to only those researchers who are working on images as evidence of connoisseurship issues or those who can't obtain sufficient information from the copy. All other researchers should use copy prints. Secure totally unprotected daguerreotypes and ambrotypes immediately. See Section G. Separate them from the collection to ensure protection against casual handling. Use a Form 10-645, Archives and Manuscript Collections, Separation Sheet to maintain the link between the object and its original location within the collection. See *NPS Museum Handbook*, Part II, Appendix D, Museum Archives and Manuscript Collections for guidance on this form. The surfaces of primary images may be damaged by careless handling because they are very fragile.

Caution both researchers and staff not to open a case completely (180 degrees) when viewing an image as this may cause severe stress on the hinge. Don't use the metallic clasps as they tend to abrade the surrounding leather or paper on the case. If the case is warped, locking the case may break the spine.

Remove loose surface dirt from the case's interior and exterior surfaces with a soft brush. Don't use other cleaning methods because the unprotected surfaces of both daguerreotypes and ambrotypes are extremely sensitive and must be handled with utmost care. Only a trained conservator should clean these materials following a careful assessment of need.

3. *How do I handle glass plate negatives and*

Collodion and gelatin glass plate negatives and transparencies are very susceptible to damage. Their weight, bulk, and inherent fragility often pose

transparencies?

the potential for serious handling problems. When handling glass plate collections, follow these guidelines carefully:

- Never underestimate the weight of glass. When working with these materials, be sure to have a firm grip on all enclosures in which glass plates are housed.
- Always handle glass on a padded and smooth work surface. You can construct this type of surface by padding a rigid piece of eight-ply board with successive layers of unbleached linen followed by sheets of lens tissues attached to the reverse of the work surface with pressure sensitive tape. As the surface becomes dirty, the sheets of lens tissue can be easily removed.
- Never handle the emulsion surface of a glass plate negative or transparency directly. Wear unpowdered latex gloves, since cotton gloves may be awkward and are inappropriate for the handling of glass artifacts.
- Before removing glass plate negatives or transparencies from their original (and often opaque) storage enclosures, always examine them carefully to determine the negatives' condition. In some cases, binder layers may be actively flaking and/or partially adhered to their enclosures. Glass supports may be broken or cracked. Safe removal may require that the original enclosures be slit at two edges with a microspatula and the plate carefully removed without scratching the glass or emulsion.
- Duplicate these fragile materials whenever possible. Use the copies for duplication services and reference purposes in order to avoid unnecessary handling of the original materials.

4. *How do I handle film-base black-and-white negatives and transparencies?*

Carefully restrict access to all film negative or transparency collections. The chemical by-products of deteriorating film could be dangerous to staff and visitors, resulting in skin and eye irritation, headache, nausea, and respiratory difficulty

You can mitigate these effects by taking the following precautions:

- Improve room ventilation and air quality by changing the position of supply air registers and the overall level of air movement
- Use fans to maintain air movement while working with these collections
- Wear protective gloves at all times when handling film collection material
- Wear an appropriately rated respirator when handling large quantities of these materials. Respirators are not considered protective if facial hair interferes, because a proper fit cannot be assured. The respirators must be fitted to each employee. See NPS-50, *Guideline for Loss*

Control Management, Release No. 2, Chapter 32, Respiratory Protection Program, for detailed guidance.

- Limit exposure time by staff and visitors

See *MH-I*, Chapter 11, Curatorial Health and Safety, for additional guidance.

5. *How do I handle slide collections?*

- Handle slide collections carefully to protect them from physical damage, fingerprints, and dirt.
- Don't leave slides in illuminated viewers or on light tables for longer than is absolutely necessary. (Kodachrome slides are particularly sensitive to light fading.) Also, don't leave slides uncovered on desks and table tops, as this exposure to ambient light may induce irregular fading and image deterioration.
- Keep the projection time for original slides to a minimum and use expendable duplicates whenever possible.
- Don't use high-intensity xenon arc projectors or other projectors that have been modified to increase their light intensity. It is usually light, and not heat, that causes fading when a slide is projected. (Some slides, however, may be more susceptible to heat-related damage, such as those with silver images including Polaroid Polachrome instant color slides and all types of black-and-white transparencies.)

**E. Preventive Conservation:
Storing Photographic
Collections in the Proper
Environment**

Environmental stability is essential to the longevity of all photographic collections. Where different types of photographic collections are stored in one space, you will need to set up many microenvironments in boxes or cabinets. Find the mean average humidity of what all materials in the room may need and use silica gel, humidifiers, or dehumidifiers as necessary to adjust the relative humidity. Specific materials need specific preventive conservation measures.

1. *How do I store photographic prints?*

Store photographic print materials at a **constant** relative humidity (RH) between 30% and 50%, in dark storage (boxed). Avoid RH fluctuations of more than 5%. Exposure to high relative humidity levels dramatically accelerates the rate of deterioration and can result in the oxidation of silver image materials, binder layer staining, mold, and even permanent changes in size and shape. Excessively dry conditions, on the other hand, may cause cracking, crazing, and embrittlement.

Store most photographic prints at 20°C (68°F) or below. Store contemporary color print materials at 4.4°C (40°F) or below.

The fading of color images is primarily controlled by the storage temperature and to a lesser degree by relative humidity. In all cases, carefully monitor temperature and relative humidity levels as described in *MH-I*, Chapter 4, Museum Collections Environment. See Figure R.2 for relative humidity and temperature requirements for various media.

Also, you will need to monitor and control (through air filtration) the levels of particulates and gaseous pollutants such as nitrogen dioxide, sulfur dioxide, hydrogen sulfide, and ozone.

Type of Photograph	Storage Temperature	Storage RH (Relative Humidity)
Most photographic prints, black and white negatives, direct positives, and transparencies	<68°F (20°C)	30-50% RH
Ambrotypes, daguerreotypes, and tintypes (Cased and Uncased)	65-68°F (18-20°C) ±2°	40-50% RH
Glass plate negatives and positives	68°F (4.4°C) ±2°	35% RH±3%
Black-and-white silver gelatin film based negatives cellulose nitrate and acetate	As low as possible	20-30% RH
Color photographic prints, negatives, slides, and positive transparencies	35-50°F (2-10°C)	20-30% RH

Figure R.2. Relative Humidity and Temperature Requirements for Photographic Media

2. *How do I store daguerreotypes, ambrotypes, and tintypes: cased and uncased formats?*

Daguerreotypes, ambrotypes, and tintypes are composed of a wide variety of materials. Store them at a RH of 40%-50% and temperature of 18°-20°C (65°-68°F).

Brass mats and preservers and iron supports of tintypes corrode at high relative humidity levels. Also, the glass used in glazing materials or actual supports for these photographic images is often chemically unstable. Don't store them in relative humidity conditions above 50% RH. On the other hand, leather, paper, and wood may become embrittled and cracked if stored in very dry conditions, contributing to structural deformations of the case. Maintain the relative humidity for these materials above 40%.

3. *How do I store glass plate negatives?*

Historic glass plate negatives are complex, laminate objects that require specific and controlled storage environments. The safe relative humidity range for the storage of glass plate negatives at room temperature conditions is 35% ± 3%. Avoid temperature and relative humidity fluctuations.

If the relative humidity is too low (below 30%), you may see severe flaking of the image-bearing layer from its glass support. If RH is too high (greater than 40%), you may see glass corrosion, silver image deterioration, microbiological attack, and even physical damage to the binder layer and varnish coatings.

4. *How do I store film-base*

One of the most pressing problems facing large photographic holdings is

black-and-white negatives?

the active and rapid deterioration of their film-base negative collections. Many unique images exist only as negatives. You will need to give the preservation of their informational content the highest priority.

Store these materials at 20%-30% RH and at temperatures as low as possible.

A very significant increase in film life is possible when storage humidity is lowered below 50%. Lowering the RH from 50% to 20%, for example, can improve expected film life four-fold.

Some other storage considerations for film-base negatives:

- Use a cold storage vault or commercially-available frost-free refrigerator or freezer to retard deterioration and prevent irreversible loss. Select these units carefully and monitor them routinely for temperature and relative humidity levels. See Section F.10.
- Restrict access to the materials housed within these units to staff who have been instructed in the procedures for collection retrieval of refrigerated or frozen items.
- Pack the negatives carefully in boxes. House negatives in Ziplock brand bags with humidity indicator strips.
- Use copies to access the original negatives in cold storage for copying or reference. If you must remove the originals for any reason (such as if you have a power outage of greater than 48 hours) allow them to acclimatize at room temperature for several hours before allowing access and use.
- Store deteriorated film-base collections in a well-ventilated location.
- Segregate nitrate films from other collections, preferably in their own freezer.

5. *How do I store color photographic collections?*

Color materials, including color negatives, slides, positive transparencies, and prints, are considerably more complex in construction than contemporary black-and-white materials. The storage environment is important.

Store these materials at 20-30% RH with a maximum temperature of 2°-10°C (35°-50°F). Store them for long-term at the lower rate, and be sure to avoid cycling. With color print, negative, transparency, and slide collections, storage *temperature is the most significant factor* in determining the rate of image fading and staining. Each -12°C (10°F) reduction in temperature will approximately double the life expectancy of color materials, as long as they aren't removed regularly from cold storage. High RH levels (greater than 65% RH) will promote the growth of fungus on emulsions, resulting in irreversible damage.

Color photographs are typically composed of at least three separate dye layers, consisting of cyan, magenta, and yellow organic dyes. The specific

deterioration of these color photographic processes is often characterized by an overall loss of density; shifts in color balance caused by the unequal fading of the cyan, magenta, and yellow dyes; changes in contrast; loss of detail; and overall yellowish staining.

In addition, color photographic prints may crack and delaminate due to exposure to light or to widely fluctuating relative humidity.

*Color image deterioration is the result of inherent instability of organic dyes. Consult Henry Wilhelm's and Carol Brower's book, **The Permanence and Care of Color Photographs: Traditional and Digital Color Prints, Color Negatives, Slides, and Motion Pictures for more specific information on identifying and categorizing these unique deterioration characteristics.***

6. *What characteristics do I need to know about color photographic collections?*

- ***Dye fading that occurs in dark storage.*** Like light fading, dark fading stability is also specific to the type of color film or print materials. The rate of dark fading is primarily a function of temperature and typically results in a final shift in color balance, as the cyan, magenta, and yellow dyes fade at differing rates.

Some color processes, such as Ilfochrome and Kodak Dye Transfer, are very stable in the dark. Kodachrome slide film is more stable in dark storage than Ektachrome slide film. Ektachrome, however, is more stable than Kodachrome if they are routinely projected.

- ***Dark storage yellow stain formation.*** This type of deterioration typically occurs with some color (chromogenic processes, including Kodachrome and Ektachrome) materials and often is a more serious problem than dye fading. For example, many Kodacolor prints dating from 1942-1953 now exhibit severe yellow stain formation especially prominent in their margins. This discoloration is caused by the unstable magenta dye-forming color couplers that remained in these prints following processing.
- ***Choice of processing method.*** The method of processing (stabilized or water wash) will often directly influence final image stability and the rate of stain formation. The image stability of instant color photographic processes (a stabilized process), for example, is very poor. Objectionable levels of yellowish stain may be observed in these stabilized, non-water washed materials after only a few months of dark storage.
- ***Processing shortcomings.*** Decreased dye stability and/or increased stain levels may result if color materials are processed using improperly replenished or contaminated chemicals or if the photograph isn't washed adequately so that residual processing chemicals remain. See Section G for a list of ANSI standards.
- ***Image fading, staining, or physical deterioration.*** These factors may be worsened by post-processing treatments. The application of lacquers, retouching materials, and high-pressure mounting techniques may adversely affect a photograph's final image stability.

F. Preventive Conservation: Housing Photographic Collections

1. *How do I house photographic prints and negatives?*

Consider funding and staffing, environmental conditions, and the use of the collection when deciding which type and style of enclosure to use. Individually folder, sleeve, or interleave mounted and unmounted photographs within acid-free boxes or stainless steel file drawers. Suitable photographic enclosure materials may be composed of chemically stable plastic or unbuffered, neutral pH paper materials. See *COG 14/2, Storage Enclosures for Photographic Prints and Negatives*.

Use the following guideline when selecting and ordering supplies, and require that the vendor meet its specifications: ANSI Standard IT9.2 1991, *Photographic Processed Films, Plates and Papers - Filing Enclosures and Storage Containers* (see Section K).

See the NPS Tools of the Trade (TOT), A Listing of Materials and Equipment for Managing Museum Collections, for sources of housing materials as well as other curatorial supplies discussed in this appendix.

2. *What about paper photographic storage enclosures?*

Paper storage materials must have passed an accelerated aging test known as the Photographic Activity Test (PAT). (Check with the vendor.) The PAT determines whether there will be harmful chemical or physical interactions between a photograph and its paper enclosure over its storage lifetime. (The PAT is described completely in ANSI IT9.16-1993.)

Photographic storage enclosures made of paper should have a high alpha cellulose content, a non-degraded form of cellulose frequently found in high-rag-content paper most desirable for paper to be permanent. Paper enclosures should contain no lignin, ground wood, or alum-rosin sizing. Printing ink shouldn't bleed or transfer, nor affect the image of the photograph.

The enclosure materials should be pH neutral at 7-7.5, and the paper *must be unbuffered* (not have an alkaline reserve). Current research, however, indicates that using buffered enclosures to house salted paper, albumen, gelatin, platinum, and collodion processes isn't detrimental provided humidity levels are maintained. It isn't necessary therefore to replace present buffered enclosures with unbuffered materials; however, purchase unbuffered paper enclosures when choosing new supplies.

Contemporary color processes, most particularly dye transfer and cyanotypes, require the use of unbuffered papers and enclosures.

There are a number of advantages and disadvantages in using paper enclosures for photographic storage. They are easy to write on and are generally less expensive than plastic materials. They are opaque, thereby protecting photographs from light. Unfortunately, this requires the users to remove each photograph from its individual paper enclosure prior to

examination, which increases the possibility of damage.

All enclosures should be standardized and made to fit easily in acid-free boxes. Identify the photographic image in pencil on the outside of each folder before inserting the print.

Paper enclosures are available in several forms including envelopes, seamless enclosures, and folders. Try to use the four-fold seamless storage enclosure; it has no adhesive seam to attract moisture and contribute to image deterioration. You can easily remove the image from the enclosure without danger of abrasion. You can, however, support fragile materials on two-ply ragboard (of neutral pH bond) by placing the ragboard behind the image within the envelope to provide better support.

You can also place prints in individual acid-free folders, even placing several photographs in one folder. In this situation, interleave each photograph with a neutral pH, unbuffered sheet of paper which has been cut to the size of the folder. Don't place more than 15 items in a single folder.

Various types of unbuffered paper envelopes are available from conservation supply companies. Use envelopes with a narrow side seam, sealed with a non-hygroscopic and non-reactive adhesive, rather than a thick central seam. During storage, be sure the emulsion or binder side of the photograph faces away from the seam. Use envelopes with a top flap, as the flap prevents dust from entering the envelope. Each envelope should only hold one photograph; when this isn't possible, interleave them.

Don't use glassine or kraft paper envelopes for photographic storage.

You can mat mounted and unmounted photographs with 100% acid-free neutral pH ragboard window and back mats. See *COG 13/1, Window Mats for Paper Objects*. Fragile, damaged or severely warped mounted photographs as well as all photographs exhibiting a flaking binder layer may require sink mat and mount housing for additional protection. A sink mat is a museum mat for paper objects that has a recessed section in the bottom sheet that protects the paper object from contact with the overmat or cover sheet. Use sink mats for photographs that have been hand-colored with friable media such as charcoal, pastel, conte crayon, and similar media that can easily be smeared, as well as for photographic prints that have damaged surfaces.

Never dry mount onto secondary supports or laminate previously unmounted photographic prints.

Matted photographs may be hinged into their back mats with long-fibered Japanese tissue hinges attached with wheat starch paste, or mounted with good quality paper photo corners. Don't use polyester photocorners, particularly on fragile images, because they can cause abrasion. Don't use hard plastic corners or flanges because they may not be chemically neutral and some have sharp edges that may scratch, abrade, or emboss a photograph.

Paper photo corners, which should be as large as possible, are the most convenient and safe means of attachment when used properly. You can fabricate these in-house from acid-free dense paper or purchase them from a conservation supply company. See *COG 14/1, Making Mounting Corners for Photographs and Paper Objects*. Any photograph with edges covered by the window mat may be mounted this way if it is strong enough to withstand its own weight resting on its lower corners while on display. The corners should be loose around the outer edges, to allow the photograph to expand with changes in relative humidity.

Reinforce the corners with a strip of archival quality linen tape or with pressure-sensitive tape adhered to the back mount. (The recommended pressure-sensitive tape for archival purposes is 3M 415 double-sided, polyester transparent tape coated with an acrylic adhesive.)

For storage, insert a sheet of unbuffered, lightweight neutral pH paper or polyester film between the photograph and the window mat to guard against abrasion. Examine carefully previously matted materials to determine their construction and materials stability.

3. *What about plastic photographic enclosures?*

Use plastic enclosures because they have the advantage of allowing an image to be viewed without removing it from the enclosure. This technique *greatly* reduces the possibility of handling damage and is ideal for large, high-access collections that haven't been copied.

If you use plastic enclosures, give special concern to humidity control. Photographic emulsions may stick, or "ferrotype," to the slick surface of these materials.

Use plastic materials ONLY if you can maintain relative humidity below 70%.

Suitable plastic enclosure materials include uncoated polyester and polypropylene. Don't use the following materials for housing photographic prints, negatives, transparencies or slides: chlorinated plastic such as polyvinyl chloride (PVC) or polyethylene sheeting, highly plasticized sheeting or coatings, or cellulose triacetate film.

Because of the build-up of static electricity, don't use plastic materials, especially polyester film, for housing photographs that have a flaking or friable binder layer or applied color.

Don't use plastic housing materials for images on glass, either negative or positive, as they are very prone to image flaking.

Also, one side of some polyester film photographic storage sleeves is slightly matted to avoid ferrotyping. The matting is done with silica dioxide or through roughening of one surface. Don't use these "matted" or "frosted" films for photographic storage.

You can choose from a wide variety of plastic enclosure designs available from conservation supply companies. Here are a few examples:

- **Plastic sleeve.** The sleeve is a plastic enclosure that opens along two or three sides. One particular polyester sleeve design you may want to use opens along both long sides with a flap. The flap allows inserting and removing of the photographs without potentially dangerous sliding. "L" sleeves, sealed along a long and short edge, also allow for easy and safe access to a photographic print.

You can cut neutral pH, unbuffered mat boards (.01"-.02" thickness) to standard sizes and then insert them into the plastic sleeve, behind the photograph. The clear plastic sleeve allows the photograph to be viewed without being removed, and therefore protects the photograph from scratches, dirt and fingerprints. The neutral pH, unbuffered board neutralizes acids, provides fragile photographs with additional support, and allows the print to be identified without labeling directly on the image.

Take care when handling sleeved photographs, since they may slip or fall out of the open sides of the enclosures.

- **Polyester folder.** This enclosure is made by welding two sheets of polyester film together along one edge. These folders are most successful when used inside neutral pH, unbuffered paper envelopes. The polyester folder protects the photograph from handling whenever you remove it from the envelope.
- **Polyester sheet with multiple pockets.** You can use this system for housing small mounted and unmounted photographic prints within a larger-sized standard folder. It consists of two polyester film sheets that have been welded together to form standard-sized clear polyester film pockets or pouches. To maintain the original order of a collection, all images should be of the same size if this system is being used. Therefore, it may not be practical for a varied size collection.
- **Unbuffered acid-free folder with polyester film overlay.** This paper folder has the addition of a sheet of clear polyester film attached to its inside, along the right margin. It can be made in-house or purchased from archival vendors. This storage enclosure is particularly effective for housing unmounted and fragile albumen photographs that often have a strong tendency to curl.
- **Polyester/ragboard enclosure.** These "handling folders" are available commercially in standard sizes. They consist of a sheet of polyester film adhered at two edges in an "L" shape, adhered to a fractionally larger sheet of four-ply buffered acid-free ragboard. The photographic print is slipped under the polyester sheet and housed flat. This enclosure provides unmounted and fragile photographic prints with additional protection. However, mounted photographs are more likely to slip and slide within it, so this design isn't appropriate for all photographic formats.

4. *How do I house panoramic (oversized) prints?*

Panoramic prints, usually longer than “normal” photographic prints, are often found in a tightly rolled and vulnerable configuration. While you can flatten a loosely rolled print by placing it between two pieces of clean, dry, blotting paper under weights, many tightly rolled prints will crack and tear irreversibly if forced open without the proper humidification and flattening procedures. Consult a trained photographic conservator if in doubt.

You can house flattened panoramic prints in polyester film sleeves with a fold-lock closure at the long edge. You can purchase pre-welded lengths of rolled polyester in a variety of widths that can be cut to size as required. You can also insert a four-ply ragboard support into the sleeve for increased protection. Be sure to transfer any identification information from the back of the print to the back of the board *before* housing the print in the sleeve.

You also may house panoramic prints flat in heavyweight paper folders. In some instances, it may be necessary to house these large format materials rolled onto neutral pH unbuffered tubes. Take care that the diameter of the tube is sufficiently large (4" or greater) to ensure adequate protection of the photograph. Once rolled with the binder side inward, cover the tube with polyester film, attached with a Velcro button closure.

5. *How do I containerize sleeved prints?*

Once they are housed in individual storage enclosures, you can place photographic prints in acid-free file folders and special acid-free storage boxes that are free of lignin, ground wood, and alum-rosin sizing. Paper and board stock used to construct these storage boxes may be buffered (have an alkaline reserve). Use flat storage, in shallow acid-free boxes or flat file drawers, for fragile photographs and those that are adhered to brittle mounts. Be sure that all folders or enclosures exactly fit the inner dimensions of the storage box, so that they will stack neatly and not shift dangerously.

If they are in generally good condition, you can store 10" x 12" or smaller photographs upright in boxes or acid-free hanging file folders. Boxes and file cabinets must not be overcrowded, but also must not be so loosely filled that all support is lost. Equip vertical file drawers with rigid support of metal or acid-free mat board every 6"-8".

Fire resistive (insulated) filing cabinets are not recommended because they don't use space efficiently. They also are bulky for storage areas, and very expensive. A better storage method is to house photographs upright in boxes on steel shelving units.

6. *What storage techniques do I use to rehouse photographic materials?*

No single storage system is ideal for all photographic materials. Base your storage decisions upon format, type, condition, use, and value of the photographs. Those materials that are most heavily used should probably be rehoused first, followed by original photographic prints of high value and/or in fragile condition. A strategy for setting priorities is described in *COG 19/10, Reformatting for Preservation and Access: Prioritizing Materials for Duplication*. In order to reduce damage caused by handling, house those photographs most often used and requested in plastic enclosures. In all cases, use standard-sized storage enclosures only.

Photographic objects are particularly susceptible to the potentially reactive and volatile by-products released by some of the materials used in the manufacture of storage cabinets. Use only galvanized or stainless steel cabinets or steel cabinets coated with a baked-on-enamel finish or non-reactive powder coatings. These powder coatings are made by electrostatically applying powdered epoxy resin that is fused to the enamel finish with heat. No solvents or plasticizers are used in the process.

Remove paper clips and staples from all photographs before storing them. Rusty paper clips or staples or other metal attachments may permanently stain, fade, emboss, and/or tear photographic prints. See *COG 19/5*, Removing Original Fasteners from Archival Documents.

During rehousing, examine all photographic items to assess the need for further preservation treatment. Learn to identify those deterioration problems that require immediate conservation treatment, such as photographic materials exhibiting actively flaking binder layers, the presence of pressure-sensitive and rubber-cement adhesives, and severely deteriorated and embrittled primary and secondary supports.

The presence of active mold growth is another critical problem that you should address immediately. You can prevent continued bio-deterioration by removing spores via aspiration, and then controlling the environment stringently.

7. *How do I house daguerreotypes, ambrotypes, and tintypes: cased and uncased formats?*

These objects are frequently found housed in their original decorative folding cases that were often constructed of wood covered with embossed leather or paper. The photographic images are protected by a lacquered brass mat and a cover glass, usually bound together with paper tape and further covered with a decorative brass foil or preserver.

Each miniature-cased object should have individual housing protection in the form of a wrapper or container that conforms to its three-dimensional format. You can house cased photographs in individual, custom made, four-flap boxes of heavyweight acid-free folder stock. Boxes are also available from a variety of conservation suppliers in stock sizes.

Write the catalog number and other identifying information in pencil on the outside of the box. If possible, use acrylic adhesive on 3M mounting tape to adhere a 35mm contact print of the image to the outside of the storage box to help minimize handling of these fragile artifacts. Store the arranged cases flat, by size, in acid-free boxes or padded drawers. Vertical storage may be necessary for larger collections where space is a problem.

- ***Loose daguerreotype plates.*** These materials are extremely vulnerable, so give them the highest priority for protective housing. This may consist of a sink mat (see Section G), alumina silicate cover glass, and a pressure-sensitive tape seal. The sink mat may be fabricated from an acid-free unbuffered ragboard or die cut from 60 point polypropylene sheeting. To ensure adequate protection, use ragboard that has passed the PAT. When purchasing ragboard, check vendor's specifications. Filmoplast P-90 and Permacel J-Lar 4000 pressure-sensitive tapes have been successfully used for binding daguerreotypes. These chemically

stable tapes are both manufactured using an acrylic adhesive. J-Lar provides a better barrier to moisture. The specific composition of these tapes may change in time. Therefore, rehoused daguerreotype plates must be carefully monitored to ensure that their deterioration isn't progressive.

Identify actively deteriorating cover glasses and replace them, as time permits, with contemporary glass. Ask a conservator to supervise all uncasing and resealing operations.

- **Loose ambrotypes.** House loose ambrotypes in four-flap neutral pH paper enclosures or envelopes. Protect the glass support from breakage by including a four-ply neutral pH ragboard sheet. House broken or cracked ambrotype supports in a sink mat, or sandwich them between two sheets of ragboard to await further treatment. Note that the ambrotype's surface is easily abraded and scratched, although the surface isn't as delicate as the daguerreotype's surface.
- **Loose tintypes.** House loose tintypes in good-quality paper or plastic, such as polyester and polypropylene film, enclosures. Four-ply ragboard inserted behind the tintype will provide its flexible support with additional protection. House sleeved tintypes vertically in acid-free boxes (never in plastic enclosures).

For tintypes that exhibit a flaking collodion binder layer, use four-flap paper enclosures only.

8. *How do I house glass plate negatives and positives (lantern slides)?*

Use a four-flap neutral pH paper enclosure for storing glass plate negatives and lantern slides in good condition. These enclosures should meet ANSI IT9.2 specifications (see Section K).

Storing each plate in its own enclosure prevents rubbing and abrasion on the plate. When using the four-flap enclosure, place the glass plate image in the center with each flap carefully folded over the emulsion side. This avoids the necessity of sliding the image in and out of the enclosure. Write any pertinent information in graphite on the outside of the seamless enclosure before the image is inserted. Some commercially made paper sleeves aren't suitable for glass plate storage, as photographic emulsions can be irreversibly damaged through the action of sliding the plate in and out of an envelope.

Never use plastic sleeves, envelopes, or folders with glass plates. Don't place glass plates in cold storage.

Caution: Only excessively dirty materials and/or those designated for duplication require cleaning. You should only attempt this cleaning after determining the emulsion side of the glass plate, usually the less glossy side. (If a question remains, consult a conservator.) During rehousing, carefully clean the non-emulsion or base side of the glass plate with a soft brush followed by a cloth slightly dampened with distilled water. Don't allow moisture to come in contact with the emulsion side of the glass plate.

House all glass plates according to size after making careful notes on their original order. Store glass plate negatives and lantern slides that are in good condition and smaller than 10" x 16", vertically (upright) on their long edge within the sleeves. Store them in metal file drawers or in acid-free, flip-top, reinforced boxes that contain no lignin, ground wood, or alum rosin sizing.

In each case, cut pieces of four-ply neutral pH ragboard to the size of the enclosures and place them as rigid dividers between every five to ten individually enclosed plates. These dividers will help support the weight of the plates and will also ensure that these fragile glass plates remain in an upright position as the collection is accessed by staff. Insert additional dividers or wedges to fill up extra space in a box or drawer.

Don't use traditional wooden grooved boxes for glass plate storage.

Cracked or broken glass plates should be duplicated to eliminate the need for further handling. Support them on their emulsion side with a clean, clear single-weight piece of high alumina silicate glass or non-textured Plexiglas of the same dimension. Protect the supported plate on both sides with four-ply neutral pH ragboard also cut to the size of the damaged negative. Then seal the sandwich at all edges with Filmoplast P-90 pressure-sensitive tape, and note the subject matter and condition on the ragboard support.

House glass plate negatives that exhibit active flaking or deteriorated binder layers and/or broken glass supports in custom-made neutral pH sink mat housings. Build these mats out of acid-free, single-walled corrugated board, laminated together with 3M 415 double-sided pressure-sensitive tape. Use neutral pH ragboard shims, attached to the back mat with 3M 415 tape to separate glass fragments to prevent abrasion along broken interfaces. Construct each sink mat with a hinged lid and be sure its height is sufficient so that its lid doesn't come in contact with the negative's surface. Standardize the outer dimensions of all sink mats.

In most cases mending isn't required and protective housing as described above should be sufficient. If mending is deemed necessary, ask a conservator to do it.

Finally, mark all folders and boxes containing glass clearly with the word "GLASS." Don't house boxes of glass plate negatives on upper or bottom shelves where they may be difficult to reach or lift.

9. *How do I house black-and-white negatives?*

Use three layers of protection when storing black-and-white negatives.

- Place each negative in a sleeve
- Place each sleeve in a box or drawer
- Place each box or drawer on a shelf or in a cabinet

House nitrate and acetate film-base materials in chemically stable buffered paper enclosures that meet ANSI IT9.2 specifications (see Section K).

House sheet film negatives in four flap seamless enclosures or envelopes with a side, rather than central, seam. If envelopes are used, insert the negatives so that their emulsion surfaces face away from the seam.

Don't use plastic materials including Mylar polyester for the storage of nitrate or deteriorated acetate negatives.

10. *Why do I place color photographic collections in cold storage?*

Cold storage is the only way to preserve color photographs in their original form for long periods of time. Therefore, with valuable color collections, be sure to use humidity-controlled cold storage for originals and copies for reference and duplication purposes.

Cold stored masters should be the originals, regardless of process. Duplication and viewing copies should be available so that the original images don't need to be removed from cold storage. Each generation of copies loses some image detail and has some color shift. Avoid introducing a copy as the master, because subsequent copies are apt to be too distorted.

While all color photographic materials will benefit from cold storage, according to Henry Wilhelm there are specific color photographic processes for which cold storage is particularly imperative. These include pre-1984 Ektacolor, Fujicolor, Agfacolor, and Konica Color prints; all pre-1991 Kodak Ektachrome prints; color negative films, especially Ektacolor, Vericolor II, Kodacolor-X, and Kodacolor II; and color transparency films such as Process E-1, E-2, E-3, and E-4 Ektachrome films, ANSCO and GAF films.

The majority of color slides are one-of-a-kind transparencies produced by the reversal processing of chromogenic (Kodachrome and Ektachrome) film. No negative remains. The most important factors you need to consider in determining the useful life of color slides is their inherent dye stability and resistance to stain formation during aging. Improper processing of color materials can also adversely affect image stability.

The stability of color transparency film varies considerably. Kodachrome film, for example, is clearly the most stable transparency film in dark storage, yet it has the worst projector fading stability of any slide film currently available. E-6 Ektachrome film, in comparison, will develop high levels of yellow stain during dark storage but is more stable than Kodachrome when projected.

11. *How do I determine what is appropriate cold storage?*

You can create cold storage either by using a frost-free refrigerator or by constructing a cold storage facility. The latter option is significantly more costly and only appropriate for large collections of materials for which the use of refrigerator units isn't feasible.

12. *What do I need to know about storage in a frost-free refrigerator?*

Refrigerated storage is vital for the long-term preservation of pre-1984 Ektacolor, Fujicolor, Agfacolor, and Konica Color prints; all pre-1991 Kodak Ektachrome prints; color negative films including Ektacolor, Vericolor II, Kodacolor-X, and Kodacolor II; and color transparency films such as Process E-1, E-2, E-3, and E-4 Ektachrome films, ANSCO and GAF films.

A frost-free refrigerator will effectively slow the fading rates and greatly extend the life of color photographic materials. See *TOT* for specific makes and manufacturers. Operate these refrigerators in a well-ventilated room, but not in the museum storage room. They give off a considerable amount of heat. In the event of a power failure lasting longer than 48 hours, unplug the unit and leave the door open until the power is restored.

- ***Environmental Monitoring and Control.*** Maintain refrigerators properly. Monitor temperature and humidity levels at all times, ideally through the use of a datalogger drilled and attached to the refrigerator for external monitoring. Use conditioned silica canisters to help maintain the relative humidity. Place a separate thermometer in the refrigerator compartment where temperatures should be adjusted to 1.7°-4.4°C (35°-40°F).
- ***Fullness.*** Don't pack the refrigerator too tightly as constant air circulation is essential. You can use the vegetable and fruit storage drawers, but never place photographic collections directly on the bottom of the refrigerator compartment. Don't block the vent for forced cold air, and don't keep food and drink in the refrigerator.
- ***Housing.*** Package all color films and prints in envelopes and boxes and place them in polyethylene bags, such as heavy duty freezer Ziplock bags, or wrap them in polyethylene with all seams carefully sealed with freezer tape. Slide collections, packaged in paper or plastic boxes or slide pages, should also be sealed with polyethylene. This eliminates the need for pre-conditioning and prevents moisture condensation on the collection materials when the refrigerator door is opened or when they are removed and warmed to room temperature. Place moisture indicators inside the bags to help monitor environmental conditions.

If it is unavoidable, then carefully seal all photographs in vapor proof enclosures such as heat-sealable, aluminum foil envelopes. In doing so, precondition these materials at a low (30%-40%) relative humidity. These kinds of storage systems come with a constant risk of improper seals and punctured enclosures, so they tend to reduce, and in some cases realistically eliminate, access to the collection.

- ***Preconditioning.*** Pre-condition valuable photographs by storing them for several days at a low relative humidity for maximum safety. Keep objects in the surrounding environment several hours while they reach equilibrium with the surrounding air. Then seal them in vapor-proof envelopes and place them in the refrigerator.
- ***Retrieval Guidelines.*** Develop proper collection retrieval guidelines in consultation with a conservator. Warm-up times will vary and are dependent upon the amount of materials being removed. Don't routinely retrieve collections from cold storage. Instead, use access and duplication copies for research access and copying.

Allow a collection to warm up for 24 hours if you must retrieve it. During this time the collections should remain wrapped in polyethylene

bags to prevent moisture condensation. Air should be allowed to circulate freely around the collections as they gradually warm to room temperature.

- **Refrigerator Selection.** If at all possible, don't use a freezer, or an older manual defrost or newer cycle defrost (energy saver) refrigerator. The unit should have separate refrigerator and freezer compartments. Both compartments must be guaranteed to be frost-free.
 - Cooling coils in the unit should be located only in the side of the freezer section. No part of the refrigerator or freezer that condenses moisture or forms ice crystals should be visible in the unit.
 - Air should be forced over the cooling coils and into the freezer section by an internal fan.
 - All cooling in the refrigerator section should come from cold air blown in from the freezer section by an internal fan.

13. *What do I need to know about storage in a cold storage vault?*

Because the design and construction of a cold storage vault for photographic materials requires specialized knowledge, you will need to select an experienced contractor and consult with curators, archivists, and conservators familiar with cold storage systems.

- **Environment.** For optimum protection, experts may recommend vault temperatures of -18°C (0°F) and relative humidity levels of 30%. These levels are difficult and expensive to maintain and aren't ideal in situations where collections are regularly accessed. For these reasons, many cold storage vaults in the United States are currently operating at 4.4°C (40°F) and 40% RH. Whatever the temperature, humidity cycling must be avoided in all cases.

Equip your vault with redundant and independent environmental systems in the event of equipment failure. Install air filtration systems to remove acetic acid and oxidizing gases. Outside the storage, install automatic dry-desiccant dehumidifiers with high efficiency particulate air (HEPA) filters. All cold storage vaults should have automatic shutdown systems that will activate when deviations from pre-set limits of temperature and relative humidity occur.

- **Housing.** Storage in a low temperature vault requires that the photographic materials be placed in acid-free boxes, portfolio cases, motion picture cans, and other enclosures safe for the long-term storage of photographs. Vapor-proof packaging isn't required.
- **Retrieval.** You also need to be aware that regular and constant retrieval of materials from cold vaults will directly affect their projected life expectancy. Heavily accessed materials may not benefit as significantly from storage in low temperature vaults—below -9.5°C (15°F). Therefore, be sure to make use and duplication copies of rare or fragile materials *before* placing the items in cold storage, so that the originals can fully benefit from cold storage and be preserved for a maximum lifetime.

Place packages removed from the vault in polyethylene bags and allow them to warm up gradually. Small packages, such as a single matted color print, should have very short warm-up times and should be available for use almost immediately upon removal from cold storage.

14. *When can I remove original photographic materials from cold storage?*

Don't remove originals from cold storage except in three cases:

- power outages of longer than 48 hours
- visits by photographic researchers who are studying details of process, format, and image manipulation
- the need to replace a damaged, deteriorated, or lost copy negative

15. *How do I house color slide collections?*

Color slides not in cold storage, such as those that may be heavily used, should be enclosed in individual polypropylene or triacetate sleeves, unless kept in permanent or inactive storage. These sleeves should fit tightly around each slide so that the slides won't fall out. These sleeves aren't necessary for glass-mounted slides because glass mounts offer protection from fingerprints and scratches. Glass mounts don't reduce the rate of fading associated with dark or light storage.

You can also house slide collections in polypropylene slide pages, available in several gauges. (These pages may be used in conjunction with individual acetate sleeves.) The heavier gauge (5.0) is recommended for its superior handling characteristics. Rigid, open frame polypropylene Saf-T-Stor slide pages supplied by Franklin Distributors Corporation are also recommended. Avoid polyvinyl chloride (PVC) pages as well as low density polyethylene. Polyethylene's physical strength is inadequate and the presence of anti-block and slip agents that have been incorporated during manufacture may promote ferrotyping of the slide surfaces.

You can house large slide collections in acid-free boxes fitted with movable interior dividers or in baked-on enamel or powder-coated cabinets, but be sure that non-glass mounted slides are carefully protected from handling.

**G. Preventive Conservation:
Exhibiting Photographic
Collections**

1. *How do I exhibit photographic prints?*

The recommended environmental conditions for the exhibition of photographic print materials are identical to those for storage: 30%-50% RH and 20°C (68°F). Never exhibit photographic prints for more than four months per year.

Never place original photographic print materials on permanent display. Consider exhibiting facsimiles or copy prints where the use of original prints isn't essential.

Restrict illumination, either artificial or natural, for display of most

nineteenth century photographic print materials to 50 lux (5 footcandles). This standard applies to all photographic materials which have exposed paper fibers, such as salted paper, platinum, and cyanotype; photomechanical processes, such as collotype and photogravure; and albumen photographs. Fifty lux (5 footcandles) also is recommended for photographic prints that have applied color such as hand tinting and/or tinted binder/baryta layers. Prints with untinted baryta layers, most silver gelatin and collodion-chloride processes, may tolerate up to 100 lux (10 footcandles) exposure.

Never expose photographic materials to direct sunlight or ultraviolet radiation. If possible, use tungsten (incandescent) or fiber optic illumination instead. Incorporate filters and diffusers with all case lighting.

It's also a good practice to monitor the condition of photographic prints at frequent intervals while they are on display. Photochemical damage is usually most apparent as a difference in appearance between exposed print areas and those protected by the window mat. You can find procedures for monitoring print materials in Section K.

All framed photographs you select for exhibition should be paper hinged or photocornered into 100% neutral pH ragboard mats and glazed with ultraviolet filtering acrylic sheeting (Plexiglas). *Only* latex paints should be used to prepare walls and exhibition spaces, since the peroxides emitted during the curing of oil-base paints will accelerate silver image deterioration.

Finally, have a conservator stabilize any photographs that exhibit serious deterioration problems before exhibiting them. See *MH-I*, Chapter 8, Conservation Treatment, for guidance on conservation treatment.

2. *How do I exhibit daguerreotypes, ambrotypes, and tintypes: cased and uncased formats?*

A cased object consists of the photographic image, decorative brass mat, and cover glass. These components are usually sealed with paper tape and flexible brass preserver. The photographic images themselves aren't particularly light sensitive (for example, a daguerreotype plate won't fade upon exposure to light). However, the dyed decorative fabrics, paper, and leather integral to case construction, as well as some of the pigments used in hand coloring, are very susceptible to fading. Natural resin varnish layers on tintype and ambrotype surfaces may yellow upon exposure to light.

Exhibit cased objects within closed display cases at low light levels (50 lux or 5 footcandles) for limited periods of time.

You also should maintain stable temperature and relative humidity levels within these cases. A sudden rise in temperature may cause an ambrotype's black lacquer backing to irreversibly crack and craze or a daguerreotype's gilded surface to exfoliate.

3. *How do I exhibit color photographic collections?*

All color prints, with the exception of Ultrastable Permanent Color, will fade when exposed to light during exhibition. Different types fade differently with some lasting significantly longer than others. Never subject valuable or non-replaceable color prints to prolonged (more than

one week) display. Use copies instead.

For most color print materials the spectral distribution of the illumination source, for example, incandescent versus fluorescent, has relatively little effect on their fading rates. In fact, it is the intensity of illumination that is important.

Keep illumination levels low: 50 to 100 lux (5 to 10 footcandles) is frequently recommended for the exhibition of color photographic material. Also, be sure to monitor prints with a reflection densitometer prior to and following exhibition, in order to have a qualitative record of a print's original condition and the complex changes that may take place following exhibition. Consult a photograph conservator for procedural guidelines to ensure that prints aren't damaged during the monitoring process and that the results are valid.

Color images deteriorate due to inherent instability of organic dyes. Wilhelm (previously cited) identifies and categorizes these unique deterioration characteristics. The characteristics pertaining to exhibited collections are as follows:

- Fading caused by exposure to light and ultraviolet radiation during display or projection. The rate of light fading is a function of the intensity of illumination and the duration of exposure. The rate of fading is also specific to each type of color film and print material. Most Kodak Ektacolor RC prints made between 1968-1977 and displayed for extended periods of time, for example, now exhibit severe image fading and color balance shift.

The light fading characteristics of modern materials vary considerably. Most modern chromogenic color print materials have an ultraviolet-absorbing coating and, therefore, UV radiation isn't considered to be a major contributing factor to the light degradation of these materials. Most of the fading that occurs with these papers is caused by exposure to visible light. Ilford, Ilfochrome and Kodak Dye Transfer prints don't have UV-absorbing coating. These materials will be quickly and irreversibly damaged by exposure to ultraviolet radiation. Ektachrome slide film is more stable than Kodachrome when the processes experience regular exposure to light.

In general, you should carefully restrict the exhibition of original color photographic prints and, where acceptable, substitute facsimile copy prints for long-term display.

- Light-induced yellow stain formation. For most modern color materials light-induced staining is a relatively minor problem when compared with the irreversible fading of cyan, magenta, and yellow dye layers.

H. Preventive Conservation: Inspecting Photographic Collections

1. *What is the Condition Checklist for Visual Images?*

The Condition Checklist for Visual Images provides a simple way for conservators or park curators who are familiar with visual images and their conditions to record the overall condition of an image, group of images, or collection, as well as the control numbers, location within a specific collection, physical process, format, and techniques, and specific deterioration conditions.

2. *How do I use this checklist?*

The form can be used to record this information for: a single image (for example, negative 5, of folder 9, of box 3, of collection X); a group of images (for example, negatives 43-97, of boxes 1-2, of collection X); an entire collection (for example, negatives 1-2000, of boxes 1-20, of collection X). When using the form for more than one image, check all categories that apply for that group of materials. You may need more specific data for planning purposes, such as the estimation of the amount of treatment work needed or rehousing needs. In such cases, use specific numbers to indicate the quantities of images that exhibit a specific trait (for example, brittleness 10 indicates that 10 images exhibit brittleness in the materials being evaluated).

3. *Where do I find the checklist?*

See Figures R.3a and R.3b for the checklist. An unpunched full size checklist accompanies this appendix. Keep the full size checklist as a master and make copies for your use.

I. Conservation Treatment Issues for Deteriorated Photographic Materials

1. *What does this section cover?*

This section describes appropriate treatments for different kinds of deteriorated photographic print materials in order to give you a sense of what will need to be done. In some cases, no treatment may be appropriate. In all cases, have a conservator treat these materials.

2. *Why use a conservator?*

In devising a valid treatment proposal, a conservator will evaluate the physical condition and chemical composition of all components that may be incorporated into these photographic materials, including the secondary support and its method of attachment, as well as the presence of hand coloring, retouching, and/or additional varnish layers. Historic and contemporary photographic materials are composed of a wide variety of organic and inorganic compounds, synthesized into a complex, multi-layered structure. The conservator will:

- consider potential reactions and interactions of these materials to proposed conservation treatment procedures.
- evaluate the photograph's historic and aesthetic integrity as well as the short- and long-term risks and merits of a particular treatment procedure

- identify the purpose (exhibition versus storage) and scope (single item versus large group) of a particular treatment in order to determine the nature and extent of possible reconstruction or restoration
- propose a viable treatment procedure to the curator that is based on all of these critical factors

3. *What are the ethical considerations?*

An accurate discussion of current conservation treatment practice should include an acknowledgement and understanding of the ethical principles and standard guidelines that conservators follow. All conservators are bound by a Code of Ethics. See *MH-I*, Chapter 8, Conservation Treatment, and Appendix D, Code of Ethics, for a detailed discussion of conservation treatment and the Conservator's Code of Ethics. These codes address the critical issues of treatment practice, such as:

- In the treatment of photographic materials, all actions must be governed by respect for the integrity of the photograph including its physical, historical, aesthetic, and cultural significance. The conservator must adhere to the highest and most exacting standards.
- The conservator must restore deteriorating materials according to an understanding with the owner, custodian and, in some cases, the photographer, if living. Conservation treatment must not modify or conceal the true nature of the object. It must be detectable, although it need not be conspicuous, and must be fully documented. A conservator must use appropriate materials and techniques that will have the least adverse effects and that can be removed most easily and completely. Conservation treatment procedures must not impede future examination or treatment possibilities.

Condition Checklist For Visual Images

Control Numbers:

Accession number(s) _____
Catalog number(s) _____
Item number(s) _____
Negative number(s) _____

Collection Name: _____

Location(s) of the Item(s) in the Collection:

Box number(s) _____
Folder number(s) _____
Item sequence number _____
Other number _____

Photographer(s): _____

Dates: _____

Physical Description:

Process(es) _____
Format(s) _____
Size(s) _____
 Color Monochrome
 Negative Transparency Print(s)
 Positive Transparency Drymounted
 Matted Framed Cased In Album
 Autographed

General Condition Analysis:

Excellent Good Fair Poor

Specific Condition Analysis:

(Check all that apply and indicate approximate quantities or percentages when dealing with large quantities)

a. Primary Support/Secondary Support:

<input type="checkbox"/> Brittleness _____	<input type="checkbox"/> Tack holes/punctures _____
<input type="checkbox"/> High acidity _____	<input type="checkbox"/> Adhesives _____
<input type="checkbox"/> Lignin content _____	<input type="checkbox"/> Tapes _____
<input type="checkbox"/> Cockling/buckling _____	<input type="checkbox"/> Discoloration _____
<input type="checkbox"/> Curling _____	<input type="checkbox"/> Waterstains _____
<input type="checkbox"/> Folds/creases _____	<input type="checkbox"/> Matburn _____
<input type="checkbox"/> Wrinkles _____	<input type="checkbox"/> Foxing _____
<input type="checkbox"/> Warp _____	<input type="checkbox"/> Mold _____
<input type="checkbox"/> Tears _____	<input type="checkbox"/> Insect/vermin accretions _____
<input type="checkbox"/> Losses _____	<input type="checkbox"/> Dirt/grime _____
<input type="checkbox"/> Holes _____	

Figure R.3a. Condition Checklist for Visual Images (Sample)

Condition Checklist For Visual Images

b. Image Layer/Media:

- | | |
|---|--|
| <input type="checkbox"/> Fading _____ | <input type="checkbox"/> Emulsion bubbling or flow _____ |
| <input type="checkbox"/> Color shift _____ | <input type="checkbox"/> Binder migration _____ |
| <input type="checkbox"/> Discoloration _____ | <input type="checkbox"/> Trim _____ |
| <input type="checkbox"/> Water stains _____ | <input type="checkbox"/> Cut _____ |
| <input type="checkbox"/> Oleaginous stain _____ | <input type="checkbox"/> Tears _____ |
| <input type="checkbox"/> Silver sulfiding or tarnishing _____ | <input type="checkbox"/> Losses _____ |
| <input type="checkbox"/> Loss of highlight detail _____ | <input type="checkbox"/> Holes _____ |
| <input type="checkbox"/> Loss of dense detail _____ | <input type="checkbox"/> Adhesives _____ |
| <input type="checkbox"/> Loss of surface gloss _____ | <input type="checkbox"/> Cloth tapes _____ |
| <input type="checkbox"/> Emulsion flaking _____ | <input type="checkbox"/> Plastic tapes _____ |
| <input type="checkbox"/> Applied color flaking _____ | <input type="checkbox"/> Dirt/grime _____ |
| <input type="checkbox"/> Bleeding/feathering of applied color _____ | <input type="checkbox"/> Dust _____ |
| <input type="checkbox"/> Surface cracking/crazing _____ | <input type="checkbox"/> Smoke damage _____ |
| <input type="checkbox"/> Surface abrasion _____ | <input type="checkbox"/> Fingerprints _____ |
| <input type="checkbox"/> Embrittlement _____ | <input type="checkbox"/> Insect grazing _____ |
| <input type="checkbox"/> Media stuck to another object _____ | <input type="checkbox"/> Mouse chew _____ |
| <input type="checkbox"/> Emulsion softening _____ | <input type="checkbox"/> Insect or vermin accretions _____ |
| <input type="checkbox"/> Emulsion powdering _____ | <input type="checkbox"/> Mold _____ |
| <input type="checkbox"/> Cockling/buckling _____ | <input type="checkbox"/> Foxing _____ |
| <input type="checkbox"/> Channeling _____ | <input type="checkbox"/> Other (Describe) _____ |
| <input type="checkbox"/> Dimpling _____ | |

Additional Comments:

Figure R.3b. Condition Checklist for Visual Images (Sample)

4. *What treatments will the conservator use?*

While many of the conservation treatments discussed apply to both nineteenth- and twentieth-century photographs, they do *not* apply to contemporary color materials. The complexity of modern color materials eliminates most treatment options.

It is important that these treatments be carried out by a conservator who specializes in photographic materials. Improperly done, these treatments will cause irreversible and catastrophic damage.

Practical, reversible, and predictable conservation treatment procedures for deteriorated photographic print materials are continually being developed and refined. However, many questions remain unanswered. Many objects are left untreated as informed conservators advocate restricted handling and stringent environmental control for the preservation of particularly fragile materials for which treatment isn't, at this time, an option.

- ***Removal of Microorganisms***

The organic constituents of photographic materials are vulnerable to microbiological attack associated with upper extremes of temperature and relative humidity. The most effective treatment in all but the most severe cases is modification of the environment and removal of the mold growth from the affected item by using a vacuum aspirator or tweezers.

Mold removal may yield a fragile and disfigured surface, requiring careful consolidation and inpainting by a conservator. Primarily because of their potential toxicity and chemical reactivity, the use of fungicides or fumigants in the treatment of mold-damaged photographic materials has been curtailed radically. See *COG 3/4*, *Mold and Mildew: Prevention of Microorganism Growth in Museum Collections*, for guidance on monitoring and controlling the environment to prevent microorganism growth in collections.

- ***Consolidation of Flaking Binder Layers***

In some cases, photographic images will exhibit moderate to severe flaking of their binder layer, thus requiring immediate consolidation by a conservator. (Consolidation is the application of an adhesive to improve cohesion between a deteriorated binder layer and its substrate.)

Consolidation techniques also may incorporate the use of aqueous or non-aqueous solutions, the choice of which is typically dependent on the physical and chemical compatibility of the consolidant and its selected solvent with the deteriorated binder layer. The use of solvent-soluble adhesives such as acrylic resins, for example, may not be appropriate for the consolidation of a deteriorated collodion binder layer. Likewise, the high pH of acrylic dispersions, often ranging from 8.0 to 9.0, may prove problematic for use with proteinaceous binders. The conservator will also need to evaluate any additional properties, such as long- and short-term reversibility, flexibility, adhesive strength,

chemical reactivity, and the possibility for irreversible visual alteration.

- ***Reduction of Surface Dirt***

Photographic images exhibiting embedded dirt and grime may be carefully surface cleaned after a conservator has thoroughly evaluated the possibility for physical or chemical damage, as well as permanent alteration in surface reflectance or gloss. Conservators employ a variety of materials and techniques in an attempt to reduce dirt and grime layers effectively from photographic surfaces. These include soft brushes, non-sulphur-containing crumbled vinyl erasers, distilled water and organic solvent solutions applied with cotton swabs and/or balls.

Severe structural damage to a binder layer may prevent dirt removal. This is often true of deteriorated albumen photographs, in which the egg white binder is severely cracked and crazed. The conservator must be extremely careful when cleaning photographs in which the final image material is embedded in the paper support, such as salted paper or platinum prints, as these images are abraded easily.

On film-based negatives and transparencies and slides, park staff may use compressed air available in aerosol cans (for example, Dust-Off, Omit) to reduce surface dirt. This procedure should be performed under the guidance of a conservator and only on film in good condition with no evidence of physical damage. Some aerosol-canned products contain oily gray substances. Test first by spraying on a white blotter.

Photographic materials that have accumulated a lot of surface dirt and dust may require immediate attention by a conservator, who will safely remove superficial loosely attached dirt with a dry, soft brush.

- ***Removal of Tapes and Adhesives***

In order to safely remove paper hinges, residual adhesives, and pressure-sensitive tapes from a photograph's surface, a conservator may use direct or indirect moisture vapor, methyl cellulose poultices, aqueous solutions, organic solvents, and many other accepted paper conservation techniques.

- ***Removal of Poor-Quality Secondary Supports***

The vast majority of historic photographic prints were mounted during manufacture, with mounts usually consisting of a poor-quality lignin-core board sandwiched between two thin, high-quality papers. Lignin decomposition products may react with proteinaceous materials such as albumen or gelatin, producing a highly colored compound and/or emitting oxidants such as peroxides and causing silver and dye image materials to fade and discolor. In addition, these secondary supports are often acidic and embrittled, posing serious structural danger to the photographs themselves. If this is the case, use extreme care in handling these fragile materials, and consider conservation treatment.

If undertaking treatments of this type, the conservator will consider the historic and aesthetic integrity of the photograph's secondary support. Through careful visual and microscopic examination, the conservator will evaluate the possible deleterious effects associated with the mounted photograph's adhesive and secondary support material, as well as the sensitivity of the photograph's component structure to possible physical or chemical damage during treatment.

Typical backing removal techniques involve mechanical removal, the local application of moisture vapor or steam, and/or immersion in aqueous or organic solutions. Treatment choice will be dictated by the photograph's structural and chemical condition. Inadequately hardened gelatin prints, for example, may swell dangerously when exposed to moisture. Exposure to moisture via surface cleaning, humidification or immersion will likely cause albumen binder layers to crack and craze, with a resultant loss of surface gloss. Many albumen and silver gelatin photographic prints, therefore, may require absolutely dry techniques, such as the use of metal or Teflon spatulas, for the safe removal of their deteriorated secondary supports.

- ***Humidification and Flattening***

Humidification and flattening of rolled, cockled or warped photographic prints are critical operations that, if done incorrectly, may induce dimensional instability, irreversible damage to a binder layer, and/or irreversible staining in the photograph's primary support. However, a conservator can develop treatment strategies for the humidification and flattening of curled photographic prints and, in some cases, park staff can be trained to carry out these procedures as well.

- ***Chemical Treatment***

An issue of considerable importance and active debate in the photograph conservation field today is the use of chemical treatment. The dire consequences of ill-advised treatments can't be ignored. For this reason, most practicing conservators agree that many chemical treatments, such as the bleach and redevelopment of faded silver images, particularly on fine art photographs, require more research before use.

- ***Structural Repair***

Photographic prints exhibiting creases, tears, losses, and other structural damages may be mended by a conservator utilizing accepted paper conservation techniques. In most cases, the conservator can mend tears successfully by using the appropriate weight Japanese paper combined with wheat starch, gelatin, or methyl cellulose adhesive.

- ***Remounting of Photographic Prints***

Photographic prints that have been removed from their mounts during treatment may require lining or remounting in an attempt to stabilize, consolidate, strengthen, and facilitate handling for exhibition and/or

storage.

In selecting the appropriate mounting technique, the conservator will consider a variety of factors pertaining to the photograph's condition and appearance prior to and following mounting. The conservator must take into account the potential for cracking or crazing of an albumen binder layer, for example due to the expansion and contraction of a wet secondary support. This may occur in many currently practiced remounting techniques.

Methods used by conservators to remount photographic prints include:

- line unmounted photographs directly onto Japanese papers or rag papers and boards using methyl cellulose or wheat starch adhesives
- line a humidified photograph with Japanese paper and wheat starch paste onto a sheet of unbuffered two- or four-ply ragboard that has been counterlined on the reverse to minimize warpage
- adhere the unmounted photograph onto a smooth-surfaced rag paper with wheat starch or methyl cellulose adhesive

The polyester fabric or "Dacron," which is then pasted onto sanded Plexiglas, acts to hold the photograph's secondary support under tension and is removed following drying.

The latter technique may be particularly suitable for the mounting of larger collections or holdings of photographic prints, as the cost of materials and time requirements can be minimized.

Each of these mounting techniques has distinct advantages and disadvantages. Discuss the ramifications associated with each of these options with your conservator.

- ***Compensation of Losses***

Following remounting, a conservator may inpaint abrasions, scratches, tear edges, and other disfiguring damage in a photograph's surface by using a variety of media, including watercolors, ground pigments in acrylic resins, and pastel pencils. In all instances, the conservator will first evaluate the long-term aging characteristics of the selected media and their "compatibility" with the damaged photograph in terms of chemical reactivity, solubility parameters, and surface qualities. The extent of compensation should also be discussed and agreed upon in collaboration with the curator or collection manager.

J. The Recovery of Water-Damaged Photographic Materials

See *MH-I*, Chapter 10, Museum Collections: Emergency Planning for guidance on emergency planning, and to Chapter 8, Conservation Treatment, for general rules on appropriate response to emergency situations involving museum objects.

1. *How should I recover water-damaged materials?*

If at all possible, water-soaked photographic materials should be air-dried, laid flat on a clean surface or hung on a line with clips that won't leave indentations (not binder clips). If you can't air-dry these materials, due to lack of personnel, facilities, and/or time, freeze them and then thaw and air-dry them later. Don't freeze glass plates or lantern slides.

Vacuum freeze-drying is the next preferable alternative. In this system place the photographs in a vacuum chamber either wet or frozen. The vacuum is pulled, a source of heat introduced, and the photographs, which dry at temperatures below 0°C (32°F), remain frozen until dried. Vacuum freeze-drying may result in a significant loss of gloss and/or a strong tendency to curl. The tendency to curl may be overcome by careful humidification following freeze-drying. In all cases, *avoid vacuum thermal-drying* whereby photographic materials are dried at temperatures above 0°C (32°F). As a result, photographic binder layers will have a strong tendency to block or stick together irreversibly. Don't vacuum freeze dry glass plates or lantern slides.

If photographs have been immersed in dirty water, a disaster recovery team should carefully wash them in changes of cold, preferably distilled, water prior to air-drying or freezing. Carefully monitor the condition of the photographs to ensure that binder layers or original ink annotation on mounts aren't being damaged. Some color processes may require bathing in a stabilizer prior to air-drying. Consult a conservator.

2. *What should I salvage first?*

In general, black-and-white photographic prints appear to be more resistant to water damage than contemporary color materials. Photographic film-base negatives are more resistant to deterioration than print materials. Depending upon the collection priority, you may want to salvage color materials first.

Mold grows after 48 hours above 65% RH and 21°C (70°F). Emulsions soften and stick if not separated during the drying process. During salvage, rescue the following first: silver gelatin processes (prints, negatives, and transparencies), glass plates, lantern slides, ambrotypes, daguerreotypes, color materials and acetate and nitrate film base. Albumen processes, collodion prints, salted paper prints, cyanotypes, and platinum prints can be done last.

K. Selected Bibliography

Photographic Processes: Identification

- Adelstein, Peter. "From Metal to Polyester: History of Picture-Taking Supports," *Pioneers of Photography*. Springfield, VA: Society of Photographic Scientists and Engineers, 1987.
- Baldwin, Gordon. *Looking at Photographs: A Guide to Technical Terms*. Los Angeles: J. Paul Getty Museum, 1991.
- Coe, Brian. *A Guide to Early Photographic Processes*. London: Victoria and Albert Museum, 1983.
- Crawford, William. *The Keepers of the Light*. New York: Morgan and Morgan, 1979.
- Gernsheim, Helmut and Alison Gernsheim. *The History of Photography*. New York: McGraw Hill, 1969.
- Hunter, John. "Chronology of Photographic Processes," *NPS Conserve O Gram* 14/3. Washington, DC: National Park Service, 1993.
- Neblette, C. B. *Photography: Its Principles and Practice*. New York: D. Van Nostrand, 1927.
- Newhall, Beaumont. *The History of Photography*. New York: The Museum of Modern Art, 1964.
- Reilly, James. *Care and Identification of 19th-Century Photographic Prints*. Rochester, NY: Eastman Kodak Company, 1986.
- _____. "The Manufacture and Use of Albumen Paper," *The Journal of Photographic Science*, Vol. 26. Bath, England: Royal Photographic Society, 1978.
- Welling, William. *Photography in America: The Formative Years 1839-1900*. New York: Thomas V. Crowell, 1978.

Photographic Processes: Preventive Conservation

- Adelstein, P. Z., J. M. Reilly, D. W. Nishimura, and C. J. Erbland. *Stability and Preservation of Cellulose Ester Base Photographic Film: Laboratory Testing Procedures and Practical Storage Conditions*. Preprint 133-3. Los Angeles: Society of Motion Picture and Television Engineers, 1991.
- Albright, Gary. "Storage Enclosures for Photographic Prints and Negatives," *NPS Conserve O Gram* 14/2. Washington, DC: National Park Service, 1993.
- Canadian Conservation Institute. "The Diphenylamine Spot Test for Cellulose Nitrate in Museum Objects," *CCI Notes* 17/2. Ottawa, Canada: Canadian Conservation Institute, 1994.
- Eastman Kodak. *Conservation of Photographs*. Kodak Publication, F-40. Rochester, NY: Eastman Kodak Company, 1985.
- Hendriks, Klaus. "The Stability and Preservation of Recorded Images," *Imaging Processes and Materials, Neblette's Eighth Edition*. New York, NY: Van Nostrand Reinhold, 1989.
- Hendriks, Klaus, and Brian Lesser. "Disaster Preparedness and Recovery: Photographic Materials," *American Archivist*, Vol. 46, No. 1, Winter. Chicago, IL: Society of American Archivists, 1983.

- Horvath, David. *The Acetate Negative Survey Final Report*. Louisville, KY: University of Louisville, 1987.
- Hunter, John E. "Filing Cabinets and Safes for Protection of Paper Records, Computer Media, and Photographic Records from Fire Damage," *Cultural Resources Management Supplement*, Volume 16, Number 5. Washington, DC: National Park Service, 1993.
- Image Permanence Institute. *Preservation of Safety Film: Final Report to the Office of Preservation, National Endowment for the Humanities*. Washington, DC: National Endowment for the Humanities, 1991.
- Image Permanence Institute. *IPI Storage Guide for Acetate Film*. Rochester, NY: Image Permanence Institute, 1993.
- Keefe, Lawrence E. and Dennis Inch. *The Life of a Photograph (Archival Processing, Matting, Framing, and Storage)*. Stoneham, MA: Butterworth Publishers, 1990.
- McCabe, Connie. "Preservation of 19th-Century Negatives in The National Archives," *Journal of the American Institute of Conservation*, Vol. 30. Washington, DC: American Institute of Conservation (AIC), 1991.
- Munro, Susan Nash. "Window Mats for Paper Objects," *NPS Conserve O Gram* 13/1. Washington, DC: National Park Service, 1993.
- Munro, Susan Nash. "Making Mounting Corners for Photographs and Paper Objects," *NPS Conserve O Gram* 14/1. Washington, DC: National Park Service, 1993.
- Newman, Jerri and Jordan, Anne. "Removing Original Fasteners from Archival Documents," *NPS Conserve O Gram* 19/5. Washington, DC: National Park Service, 1993.
- Norris, Debbie Hess. *Preservation Planning for Diverse Photographic Holdings: Photographic Preservation and the Research Library*. Stanford, CA: The Research Libraries Group, 1991.
- Ritzenthaler, M. L., Munoff, G. J., and Long, M. S. *Archives and Manuscripts: Administration of Photographic Collections*. Society of American Archivists (SAA Series). Chicago: Society of American Archivists, 1984.
- Wagner, Sarah. "Some Recent Photographic Preservation Activities at the Library of Congress," *Topics in Photographic Preservation*, Vol. 4. Washington, DC: American Institute of Conservation/Photographic Materials Group, 1990.
- Wilhelm, Henry. "Monitoring the Fading and Staining of Color Prints," *Journal of American Institute for Conservation*, Vol. 21. Washington, DC: The American Institute of Conservation, 1991.
- Wilhelm, Henry and Brower, Carol. *The Permanence and Care of Color Photographs: Traditional and Digital Color Prints, Color Negatives, Slides and Motion Pictures*. Grinnell, IA: Preservation Publishing Company, 1994.
- Young, Christine. "Nitrate Films in the Public Institution," *Technical Leaflet*, Vol. 44, No. 4. Nashville: American Association of State and Local History, 1989.

Photographic Processes: Conservation Treatment

- Barger, Susan M. *The Daguerreotype: Nineteenth Century Technology and Modern Science*. Washington, DC: Smithsonian Institution Press, 1991.

Hendriks, Klaus, and Brian Thurgood, Joe Iraci, Brian Lesser, and Greg Hill. *Fundamentals of Photograph Conservation: A Study Guide*. Toronto: Lugus Productions Ltd in cooperation with the National Archives of Canada and the Canada Communications Group, 1991.

Photographic Processes: Reformatting

Jordan, Anne. "Archives: Preservation Through Photocopying," *NPS Conserve O Gram* 19/4. Washington, DC: National Park Service, 1993.

_____. "Archives: Reference Photocopying," *NPS Conserve O Gram* 19/7. Washington, DC: National Park Service, 1993.

Puglia, Steve. "Duplication Options for Deteriorating Photo Collections," *Photographic Preservation and the Research Library*. Stanford, CA: Research Libraries Group, 1991.

Vogt-O'Connor, Diane. "Reformatting for Preservation and Access: Prioritizing Materials for Duplication," *NPS Conserve O Gram* 19/10. Washington, DC: National Park Service, 1995.

_____. "Preservation Reformatting: Selecting a Copy Technology," *NPS Conserve O Gram* 19/11. Washington, DC: National Park Service, 1995.

_____. "Contracting for Reformatting of Photographs," *NPS Conserve O Gram* 19/12. Washington, DC: National Park Service, 1995.

_____. "Preservation Reformatting: Inspection of Copy Photographs," *NPS Conserve O Gram* 19/13. Washington, DC: National Park Service, 1995.

Photographic Processes: Standards

American National Standards Institute. (See following list of standards)

ANSI/NAPM IT9.1-1992 (Silver Gelatin Imaging Stability)

ANSI IT9.2-1991 (Enclosures and Containers)

ANSI IT9.6-1991 (Safety Film Stability)

ANSI IT9.11-1991 (Safety Film Storage)

ANSI/NAPM IT9.11-1993 (Storage of Photographic Film)

ANSI/NAPM IT9.16-1993 (Photographic Activity Test)

ANSI IT9.20-1994 (Storage of Photographic Prints)

ANSI/NAPM IT9.18-1994 (Storage of Photographic Plates)

ANSI PH1.51-1990 (Photo & Micrographic Film Dimensions)

ANSI/ASC OG4.8-1985 (Residual Thiosulfate)

These items are available from the American National Standards Institute, 11 West 42nd Street, New York, NY 10036, 212-642-4900; or from the Association for Information and Image Management, 1100 Wayne Avenue, Suite 1100, Silver Spring, MD 20910, 301-587-8202.

FULL SIZE CONDITION CHECKLIST

- **This full size Condition Checklist for Visual Images is for your use.**
- **Save as a master set.**
- **Copy as needed.**

Condition Checklist For Visual Images

Control Numbers:

Accession number(s) _____

Catalog number(s) _____

Item number(s) _____

Negative number(s) _____

Collection Name: _____

Location(s) of the Item(s) in the Collection:

Box number(s) _____

Folder number(s) _____

Item sequence number _____

Other number _____

Photographer(s): _____

Dates: _____

Physical Description:

Process(es) _____

Format(s) _____

Size(s) _____

- | | |
|--|--------------------------------------|
| <input type="checkbox"/> Color | <input type="checkbox"/> Monochrome |
| <input type="checkbox"/> Negative Transparency | <input type="checkbox"/> Print(s) |
| <input type="checkbox"/> Positive Transparency | <input type="checkbox"/> Drymounted |
| <input type="checkbox"/> Matted <input type="checkbox"/> Framed <input type="checkbox"/> Cased | <input type="checkbox"/> In Album |
| <input type="checkbox"/> Autographed | <input type="checkbox"/> Other _____ |

General Condition Analysis:

- Excellent Good Fair Poor

Specific Condition Analysis: (Check all that apply and indicate approximate quantities or percentages when dealing with large quantities)

a. Primary Support/Secondary Support:

- | | |
|--|---|
| <input type="checkbox"/> Brittleness _____ | <input type="checkbox"/> Tack holes/punctures _____ |
| <input type="checkbox"/> High acidity _____ | <input type="checkbox"/> Adhesives _____ |
| <input type="checkbox"/> Lignin content _____ | <input type="checkbox"/> Tapes _____ |
| <input type="checkbox"/> Cockling/buckling _____ | <input type="checkbox"/> Discoloration _____ |

Condition Checklist For Visual Images

- | | |
|--|---|
| <input type="checkbox"/> Curling _____ | <input type="checkbox"/> Waterstains _____ |
| <input type="checkbox"/> Folds/creases _____ | <input type="checkbox"/> Matburn _____ |
| <input type="checkbox"/> Wrinkles _____ | <input type="checkbox"/> Foxing _____ |
| <input type="checkbox"/> Warp _____ | <input type="checkbox"/> Mold _____ |
| <input type="checkbox"/> Tears _____ | <input type="checkbox"/> Insect/vermin accretions _____ |
| <input type="checkbox"/> Losses _____ | <input type="checkbox"/> Dirt/grime _____ |
| <input type="checkbox"/> Holes _____ | <input type="checkbox"/> Fingerprints _____ |

b. Image Layer/Media:

- | | |
|---|--|
| <input type="checkbox"/> Fading _____ | <input type="checkbox"/> Emulsion bubbling or flow _____ |
| <input type="checkbox"/> Color shift _____ | <input type="checkbox"/> Binder migration _____ |
| <input type="checkbox"/> Discoloration _____ | <input type="checkbox"/> Trim _____ |
| <input type="checkbox"/> Water stains _____ | <input type="checkbox"/> Cut _____ |
| <input type="checkbox"/> Oleaginous stain _____ | <input type="checkbox"/> Tears _____ |
| <input type="checkbox"/> Silver sulfiding or tarnishing _____ | <input type="checkbox"/> Losses _____ |
| <input type="checkbox"/> Loss of highlight detail _____ | <input type="checkbox"/> Holes _____ |
| <input type="checkbox"/> Loss of dense detail _____ | <input type="checkbox"/> Adhesives _____ |
| <input type="checkbox"/> Loss of surface gloss _____ | <input type="checkbox"/> Cloth tapes _____ |
| <input type="checkbox"/> Emulsion flaking _____ | <input type="checkbox"/> Plastic tapes _____ |
| <input type="checkbox"/> Applied color flaking _____ | <input type="checkbox"/> Dirt/grime _____ |
| <input type="checkbox"/> Bleeding/feathering of applied color _____ | <input type="checkbox"/> Dust _____ |
| <input type="checkbox"/> Surface cracking/crazing _____ | <input type="checkbox"/> Smoke damage _____ |
| <input type="checkbox"/> Surface abrasion _____ | <input type="checkbox"/> Fingerprints _____ |
| <input type="checkbox"/> Embrittlement _____ | <input type="checkbox"/> Insect grazing _____ |
| <input type="checkbox"/> Media stuck to another object _____ | <input type="checkbox"/> Mouse chew _____ |
| <input type="checkbox"/> Emulsion softening _____ | <input type="checkbox"/> Insect or vermin accretions _____ |
| <input type="checkbox"/> Emulsion powdering _____ | <input type="checkbox"/> Mold _____ |
| <input type="checkbox"/> Cockling/buckling _____ | <input type="checkbox"/> Foxing _____ |
| <input type="checkbox"/> Channeling _____ | <input type="checkbox"/> Other (Describe) _____ |
| <input type="checkbox"/> Dimpling _____ | |

Additional Comments:

APPENDIX S: CURATORIAL CARE OF OBJECTS MADE FROM LEATHER AND SKIN PRODUCTS

A. Overview

1. *What information will I find in this appendix?*

You will find the National Park Service's present understanding of objects made of leather and skin products. You also will learn about preventive care for these objects including:

- agents of deterioration posing the greatest threat to these objects
- measures for preventing or minimizing the impact of these agents
- techniques for handling, marking, and cleaning these objects
- methods and techniques for improving storage and exhibit conditions
- methods for monitoring the condition of these objects

2. *Why is it important for me to practice preventive conservation with these objects?*

Advancements in the treatment of leather and skin products have not kept pace with the progress made in conserving other kinds of museum objects. The conservation field only can offer limited solutions to the problems facing objects made of leather and skin. Conservators and the scientific community have begun to focus more specifically on developing new treatment strategies for the preservation of leather and skin. While new information is provided as it becomes available, you need to practice sound preventive conservation now because:

- preventive measures stabilize objects and leave opportunity for appropriate future interventive treatments
- conservators can only offer limited treatment solutions

Conservators discourage traditional interventive treatments, such as the application of saddle soaps and dressings. *Avoid interventive conservation treatment of leather and skin objects whenever possible.*

See NPS Museum Handbook, Part I (MH-I), Chapter 3, Museum Objects Preservation: Getting Started, for a discussion of preventive conservation and conservation treatment.

3. *How can I find the latest information on care of these types of materials?*

Refer to the following sources for new information and techniques:

- NPS *Conserve O Gram* series
- e-mail NPS Museum Management Newsletter

B. The Nature of Leather and Skin Products

The skins and hides from vertebrates constitute the class of natural materials called skin products. Leather is one type of skin product that is produced by a particular tanning process. Processed and unprocessed animal skins have supplied the basic fabric for making utilitarian and decorative objects since prehistoric times. You will often find these materials in art, history, ethnology, and science collections.

1. *What is the structure of skin?*

Animal skin is a fibrous layer of living tissue that protects an organism from the elements. Figure S.1 illustrates its structure.

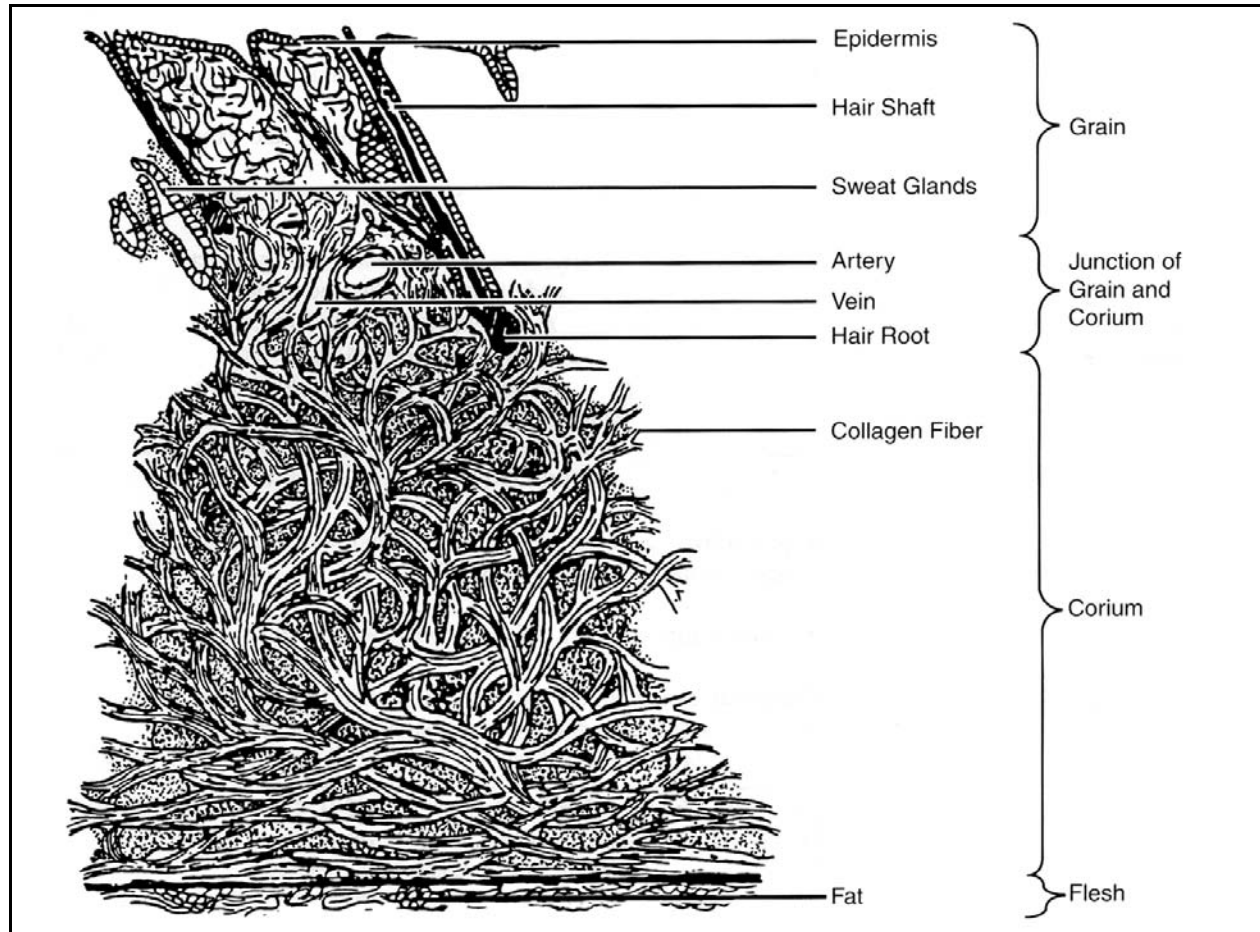

Figure S.1. The Structure of Skin

Once removed, an unadulterated skin is a proteinaceous sheet containing hair, sweat glands, fat and blood vessels, as well as its basic constituent of collagen fibers. These protein fibers are composed of coil-like molecules built of tiny fibrous strands that are twisted together, then aligned side by side overlapping one another, much like cotton fibers are arranged in a textile yarn. (To prevent separation of the cotton fibers the yarn is twisted during manufacture to produce a strong and usable thread.)

2. *How is animal skin processed?*

Animal skin can be tanned and untanned. Examples of untanned skin include rawhide, parchment, and vellum. Stable skin is processed by chemically binding fibers together, commonly referred to as tanning. The amount and type of bonding that occurs within a skin establishes its "degree of tannage." The term "leather" refers technically only to the fully tanned skin products. Figure S.2 describes degrees and types of tannage of most skin and leather objects in park collections.

Un-tanned	Semi-tanned	Native-tanned	Fully-tanned
rawhide parchment vellum	oil tannage alum tannage	smoke tannage brain tannage oil tannage	vegetable tannage mineral tannage combination tannage

Figure S.2. Degrees and Types of Tannage

People have preserved or "tanned" skin products in many ways to render them strong, insoluble, and more resistant to temperature and moisture. Nearly all of the methods of skin processing techniques used by skin and leather workers throughout the ages achieve some degree of tannage. Many of these procedures rely on mechanical properties more heavily than chemical tanning, such as the softening that results from introducing oils.

Unfortunately, determining an object's original manufacture requires considerable study. While laboratory treatments vary for different types of skins and leathers, *preventive conservation procedures are similar for most of these materials*. Your familiarity with the general skin processing categories can be very useful since these methods are responsible for many of the object's functional characteristics. See Figure S.3 for physical characteristics of these products.

3. *How do I recognize different species?*

The skin or hide of each animal species is recognizable by its physical characteristics. The principle variations among animal types are the size, density, and distribution of the animal's hair, which gives rise to a distinctive grain pattern.

The relative thickness of hide and skin products is traditionally measured in "ounces." Each ounce represents 1/64 of an inch. The black solid lines in Figure S.4. represent the thickness of leather being measured.

CHARACTERISTICS OF LEATHER AND SKIN PRODUCTS							
	RAWHIDE	OIL TANNAGE	ALUM TANNAGE	SMOKE TANNAGE	BRAIN TANNAGE	VEGETABLE TANNAGE	MINERAL TANNAGE
TANNING MATERIAL	No Tannage Applied	Cod Liver Oil and Other Oils	Alum or Aluminum Sulphates or Chlorides	Aldehydes from Wood Smoke	Animal Brains	Extracts of Wood Chips, Bark, Leaves, Roots, Fruit	Chromium Sulphates or Chlorides
COLOR AFTER TANNAGE	White to Yellow	Dull Yellow	White	Yellow to Yellow/Brown	White to Yellow	Yellow/Orange to Light Brown	Bluish White to Pale Green
EFFECT OF WATER	Stiffens, Dissolves, Turns Transparent	Water Absorbed, Tan Stable	Stiffens, Water Removes Tan	Water Resistant	Stiffens, Water Absorbed	Water Absorbed, Water Removes Tan Slowly	Water Absorbed, Tan Stable
TYPICAL USES	Saddle Trees, Drumheads, Scabbards	Gloves, Wettable Leathers	Gloves, Pelts and Furs, Book Bindings	Native American Clothing, Lodges	Native American "Buckskin" Clothing and Objects	Shoe Soles, Saddles, Book Bindings	Clothing Shoe Uppers

Figure S.3. Characteristics of Leather and Skin Products

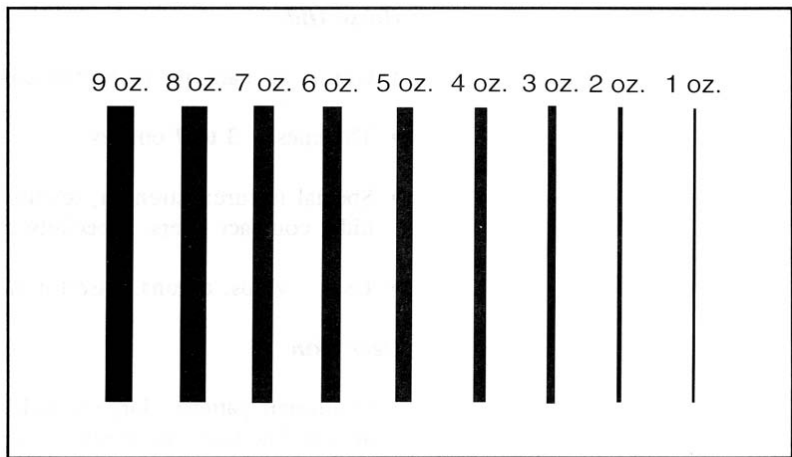

Figure S.4. Thickness of Skins and Hides

The characteristics and uses of common animal skins and hides are listed below.

Cow Hide

- Grain/hair pattern: pebbly, pronounced with large, equidistant hair spacing
- Thickness: 2 to 20 ounces
- Processing note: often split into several pieces
- Special feature: very durable, excellent for tooling and carving
- Uses: shoe soles, belting, trunks, clothing

Calf Skin

- Grain/hair pattern: same as cowhide only smaller
- Thickness: 1.5 to 4 ounces
- Special feature: greater uniformity and fineness than cowhide
- Uses: upholstery, shoe uppers, clothing, bookbindings

Bison Hide

- Grain/hair pattern: similar but less uniform than cattle
- Thickness: 5 to 20 ounces
- Special feature: loose-knit fibers on flesh side; very large hide size; stiff hump between shoulders
- Uses: 19th century boots, sleigh blankets, Native American shields, robes, clothing, tipis

Horse Hide

- Grain/hair pattern: resembles cow hide but less dense
- Thickness: 3 to 7 ounces
- Special feature: strength, texture and thickness are inferior to cow hide; compact fibers, especially in butt region
- Uses: whips, aprons, base for enameled leathers, trunks

Deer Skin

- Grain/hair pattern: large follicles form definite single rows; closely spaced fine hairs are similar to goat skin
- Thickness: 2 to 9 ounces
- Processing note: hairs are sometimes left on
- Special feature: loose structure (like sheep) results in a very stretchy leather
- Uses: parchment, gloves, clothing; Native American clothing, moccasins, containers

Sheep Skin

- Grain/hair pattern: linear groupings of large and small groups
- Thickness: 1.5 to 3 ounces
- Special feature: weaker, less durable skin (loose interweave of fibers); loosened texture (fibers run parallel to skin surface)
- Uses: suede leathers, bookbindings, jackets, gloves, chamois

Goat Skin

- Grain/hair pattern: groupings of three coarser hair follicles with closely spaced fine hair follicles
- Thickness: 2 to 3 ounces
- Special feature: close-knit collagen fibers; more durable and stronger than sheep skin
- Uses: linings, billfolds, shoe uppers

Pig Skin

- Grain/hair pattern: very coarse hairs are sparsely distributed in groups of three
- Thickness: 3 to 4 ounces

- Special feature: high fat cell content produces tough but spongy leather; very rough surface; limited water resistance
- Uses: shoes, bags, gloves, pants

Exotic Leathers

Reptile

- Special feature: surface patterns distinguish reptile type: crocodile, alligator, snake, or lizard
- Special feature: light, thin, grainless leathers often are made from bellies

Fish

- Special feature: structure is different from mammals but scales are comparable to hair on mammals

Seal

- Special feature: proportionally stronger than other leather materials; fur is left on for coats, fur is removed from base for enameled leather

C. Agents of Deterioration

The ways that skin products deteriorate can be identified and categorized. The interdependency of these mechanisms cannot be overstated. For example, temperature changes directly affect a skin or hide's moisture content, the rate at which chemical deterioration proceeds, and the object's susceptibility to biological infestation.

1. *What is the threat of biological infestation?*

A great variety of biological organisms are attracted to skin and hide products making these materials subject to quick and irreversible damage or total destruction. For example, insects are frequently attracted to the oils present in skin products as well as surface soils. Also, poorly cleaned materials are particularly attractive as a nutrient material for insects and microorganisms, as are all items made from rawhide.

Most insects prefer skin products made from fur and unborn animal skins. The most frequent infestations involve dermestid beetles and clothes moths, but other beetles and moths also attack skin and fur on occasion, as do silverfish and cockroaches.

Insect development usually relies on higher levels of humidity and temperature.

Since skin products are acidic in nature, microbic deterioration of skin products is generally limited to molds and occasionally bacteria. This deterioration is primarily due to environmental factors such as high humidity (above 65% RH) and a wide temperature range (in most cases 10°-40°C [50°-104°F]). These organisms produce organic acids and enzymes that bleach and stain the skin. Fungal growths are often

characterized by a white, gray, or green fuzzy appearance. These growths occur most commonly on objects made from rawhide and on those skin products that have become heavily soiled.

2. *How do I prevent pest problems?*

Here are some measures to prevent or minimize biological infestation:

- Monitor all areas of the museum continually and systematically to identify insect and microbial problems at an early stage. Use insect monitoring traps and routinely inspect objects for frass, nesting materials and damage. See *MH-I*, Chapter 5, Biological Infestations, for guidance on developing a museum Integrated Pest Management (IPM) Program.
- Identify dead or living pests that you suspect of attacking skin objects.
- Develop a pest control program that includes a designated staff coordinator, with guidelines for preventive and emergency measures. Its focus should be pest control through good housekeeping and modifying the environment.
- Minimize microbiological attack of skin products by keeping relative humidity below 65% and by keeping areas clean.
- Never apply insecticides and fungicides directly to hide artifacts because they can damage the objects, complicate long term preservation, and contaminate the material for future handling and study.
- Gaseous fumigation methods available for skin and hide materials are few and require coordination by a conservator. In addition, contact the park, center, or your IPM coordinator prior to pesticide use. Technology is constantly changing and the coordinator will have access to the latest and most appropriate solutions. Your IPM coordinator must authorize and approve all pesticide use before application.

Non-toxic means of extermination such as freezing are preferable. See NPS Conserve O Gram 3/6, An Insect Pest Control Procedure: The Freezing Process, for guidance on the technique of freezing for controlling pest infestations.

3. *What about the loss of hair and fur?*

The loss of hair and fur from skins and hides not only devalues an object, but also can destroy its potential usefulness. The causes of hair or fur loss are complex and usually depend on the form and structure of the animal, the hide's original processing techniques, and the environmental conditions to which it has been subjected.

There are numerous types of hair loss:

- Epidermal slippage: hair is lost as the epidermal layer separates from the dermal layer.
- Deterioration of the individual hair follicles: hair roots become loose and hair falls out.

- Hair shaft breakage: mechanical damage weakens the hair and it breaks at its base.
- Biological attack: insects feed on the hair itself or epidermal layer, resulting in the hair being severed.

You can't do much about hair loss that is due to insufficient fixing during processing, but you can control many of the other causes, such as high temperatures, low relative humidity, photochemical degradation, and insect damage.

4. *How can I stop hair and fur loss?*

To limit the loss of hair and fur:

- Minimize the exposure of fur or hair products to lighting; illuminate only to the minimum level necessary to see the object. Recommended levels are 50 lux (5 footcandles) or less.
- Minimize handling.
- Stabilize the relative humidity and temperature to which hides with hair and fur are exposed. Don't expose them to rapid changes of either temperature or humidity and protect them from desiccation.
- Routinely inspect hair and fur products for insect damage. Remove loose or broken hair by brushing and vacuuming, and store materials in insect-proof containers such as metal museum storage cabinets with door gaskets.

5. *What is the threat of thermal reaction?*

Skin and leather products are thermosensitive. Skin tissue has a heating threshold, or point of thermal contraction, which is referred to as its shrinkage temperature. For newly processed skins and hides, this point is frequently between 60°-75°C (140°-167°F). However, the shrinkage temperature of degraded hides of aged objects can be considerably lower.

Heating dries out, embrittles, and deforms skin and leather objects. Changes in temperature also can destabilize relative humidity levels. Exhibit lighting, direct sunlight, and proximity to heating registers and radiators can easily damage leather and skin objects, which also become more sensitive to heat as they age.

Elevated temperatures cause eventual damage not only by speeding up the chemical deterioration processes, but by causing unstable fats and oils to come to the surface where they often deposit as unsightly spews. Spews (also spelled spues) are surface deposits of solidified fats and oils that exude from the interior of the leather/skin material. They appear as a white crystalline deposit or as a whitish bloom. Desiccation can also result from over-heating.

6. *How can I minimize the threat of thermal reactions?*

Try these preventive measures to minimize thermal reaction:

- Safeguard skins from exposure to warm, moist air. The acceptable minimum and maximum temperature levels are from just above freezing to 20°C (70°F).

- Reduce the damaging effect of heat cycling by placing objects away from external building walls, exterior doors and windows, exposed pipes, heating and air conditioning vents, direct sunlight, exhibit lighting sources, and locations such as hot attic spaces.

7. *What about water and moisture damage?*

While skin materials have a great affinity for water, inappropriate levels of atmospheric moisture or direct wetting usually cause serious damage. The direct wetting of skin products initiates deterioration because these materials have only a limited degree of water resistance. Rawhide, parchment and vellum are most prone to damage. Aged objects made of full-tanned leather are also highly susceptible to stiffening and darkening from wetting.

All animal materials readily absorb moisture from the air. Excessive moisture (levels above 65% RH) causes swelling of the skin's fibers and encourages biological infestation. Excessive dehydration (humidity levels below 22% RH) forces the skin to give up moisture permanently, which results in shrinkage and deformity.

Dehydration reduces the skin's ability to take up and hold moisture, thus weakening it and dramatically decreasing its flexibility. Repeated exposure to moist and dry cycles will, eventually, physically stress the hide's fibers enough to induce mechanical damage and increase its susceptibility to chemical deterioration. The hide's soluble components are frequently displaced, leached, or deposited on the surface resulting in the alteration of physical characteristics.

When skin material is subjected to either excessive moisture or high humidity in conjunction with heat and acid conditions, its chemical structure is attacked, causing shrinkage and embrittlement. If allowed to continue, the skin will lose its structure and become gelatinous. The boiling of skin to produce gelatin or hide glue is an example of this process.

8. *What are the measures for limiting water and moisture damage?*

To minimize water and moisture damage:

- Keep hide materials dry by protecting them from wetting and exposure to relative humidity levels above 65%. House objects in water-resistant containers, such as storage cabinets and exhibit cases. Whenever possible, include moisture absorbing materials to buffer enclosed spaces against extreme fluctuation of RH. These materials may include commercially-available buffers such as cotton or linen cloth, acid-free paper products, or silica gel. See *MH-I*, Appendix I, Curatorial Care of Archeological Objects, for a discussion of the use of silica gel.
- Control the relative humidity to conform to the recommended levels suitable for the collection's circumstances. Stabilize humidity fluctuation to the recommended range of 40-60% RH. Normally, you will regulate humidity through the central air-handling system, but you also can use localized and portable sources of humidification/dehumidification to protect objects from unnecessary damage.
- If you discover mold on objects made of leather or skin, consult a conservator regarding vacuum cleaning and disinfectant procedures.

9. *What is the threat of prolonged exposure to oxygen?*

For organically-based materials like skin products, prolonged exposure to oxygen is one of the more serious and avoidable chemical factors that causes deterioration and is responsible for altering both the skin's chemical structure and many of its tanning compounds.

Its long-term effects include the hardening of skin and hide material, embrittlement, cracking and crazing of the skin surface and overall yellowing or darkening as well as a number of serious internal structural changes. Oxidative degradation is caused by high temperatures and humidities and exposure to light radiation.

10. *How can I minimize these oxidation reactions?*

By taking the following preventive measures:

- While it is impractical to keep most of these materials from being exposed to oxygen, if an object is extremely rare, consult with a conservator about storage and display in a hermetically sealed container filled with inert gas (such as nitrogen or helium).
- Don't expose hide materials to excessive humidity or heat. Use air conditioning, storage design and exhibit design to eliminate the detrimental effects of these environmental stimulants of oxidation.
- Reduce the level of visible light to the minimum required and eliminate exposure to ultraviolet light.

11. *What about pollutants?*

The threatening forms of pollutants to skin products are particulate and gaseous pollutants. Particulates are solids that are suspended in air and range in composition from inorganic to organic. Because skin has such a porous and absorbent surface, these solid foreign materials easily work their way into the fibrous network of skin products causing soiling, staining, and eventual stiffness.

Little data is available regarding the effect of gaseous pollutants on skin but it is probable that oxidant, acidic and sulphating gases play some role in the deterioration process. Native-tanned and semi-tanned materials seem relatively more resistant than do commercial, vegetable-tanned leathers. It is likely that pollutants promote oxidation, hydrolysis and overall discoloration.

12. *How can I minimize the effects of pollutants?*

To minimize their effects:

- Modify the building's central air conditioning and filtering system. Various filters can trap different size particles, and effectively remove gaseous contaminants.
- Exhibit and store your objects in tightly sealed enclosures constructed of the highest quality inert materials. Install specialized pollutant absorbers with individual storage cabinets.

13. *What harm can light cause?*

Light is an important factor in the process that degrades skin products. Its damage is cumulative and irreversible.

Certain wavelengths break down polymeric bonds and are detrimental to all skin materials. The ultraviolet range of light is one of the most dangerous wavelengths for skin products; however, visible light also causes structural damage and color change.

Light can act as a catalyst when oxygen, water vapor and various pollutants in the atmosphere combine to increase the rate of deterioration. The rate of degradation is generally related to the intensity and length of light exposure. Fading of smoked and pigmented hides is a particular problem where prolonged light exposure is involved.

14. *How can I minimize the effects of light?*

Take these preventive measures:

- Minimize the exposure of skin materials to visible light; illuminate only to the minimum level necessary to see the object. Recommended maximum levels are 150 lux (15 footcandles) for most materials and 50 lux (5 footcandles) for painted skins and hides with fur.
- Eliminate ultraviolet (UV) radiation through the use of UV absorbing filters installed between the light source and the artifact or on the light source itself. Select lighting systems with low proportions of UV radiation. The maximum acceptable proportion of UV radiation is 75 microwatts per lumen.
- Maintain stored objects in darkness. Ensure that unfiltered light does not reach stored skin and hide materials.
- Monitor and adjust lighting fixture locations and light bulb wattage individually. Use timers and dimmers for controlling light in exhibits.

See MH-I, Chapter 4, The Museum Environment, for general guidance on temperature, relative humidity, light, and pollution.

**D. Preventive Conservation:
Guidelines for Leather
and Skin Object Care,
Handling, and Storage**

The most successful method of preserving leather and skin products is a good preventive conservation program. This program needs to include systematic collection care, handling and storage practices, and regular inspection and condition evaluation. This approach replaces the traditional practices and remedies of the past that have been found to be detrimental to museum objects.

For longer life of skin and leather objects follow these general guidelines:

- Identify the general category of the skin product correctly.
- Understand the product's basic characteristics, as well as its deterioration features.
- Upgrade the general environment that includes controlling climatic conditions, minimizing light exposure, providing physical support, and protecting from mishandling, soil accumulation, and pest infestation.

- Inspect, evaluate, monitor, and document an object's condition, periodically; record the urgency for conservation treatment.
- Provide specialist care for those objects requiring complex or considerable conservation treatment.

And follow these specific guidelines:

1. *How do I provide a stable and appropriate humidity?*

Use enclosures such as exhibit cases or storage cabinets to stabilize humidity and reduce handling, soil accumulation, and attack from microorganisms and insects.

Set relative humidity to an acceptable range: less than 5% RH change within a 24-hour period and an annual change of no more than $\pm 8\%$ fluctuation from the set point.

Humidity parameters are frequently 40%-60% RH; however, the specific set points will vary according to:

- climatic considerations
- an object's state of deterioration
- your facility's air handling capability
- requirements of any composite and associated materials present
- the relative humidity with which the object has reached equilibrium

2. *How do I monitor the condition of objects?*

Inspect objects for deterioration regularly. If you do not regularly evaluate and document their state of degradation, deterioration of leather and skin objects can go undetected and unchecked. Evaluate the condition of objects thoroughly when they are acquired. Then, inspect the objects periodically to identify progressive damage, such as lengthening of tears, increases in surface or pigment loss, and evidence of biological attack. Finally, use a conservator to assist in periodic surveying of significant objects in order to establish conservation treatment needs. See *MH-I*, Chapter 3, Museum Objects Preservation: Getting/Started, for guidance on Collection Condition Surveys.

3. *How do I clean objects?*

The degree to which each soiled object can be cleaned is a function of the nature of the soil and the sensitivity of the object. Clean an object only as necessary to remove airborne soil accumulation.

Don't directly apply chemical reagents such as cleaners, dressings, waxes, and coatings: they are not beneficial and will complicate future conservation treatment.

You can't remove some surface soils by simple cleaning methods, and other soils are not removable at all. Highly deteriorated objects cannot be cleaned by routine procedures so degraded surfaces should be noted and protected so that cleaning will be avoided.

When decorative elements on an object are extensive and very delicate, refer cleaning to a professional conservator. Surfaces that have specialized finishes also may require exemption from cleaning. Figure S.5 describes cleaning techniques that can be considered for objects in good condition.

4. *How do I handle skin and hide materials?*

Much of the damage caused to leather and skin products is due to improper handling. Therefore, you need to train staff in proper handling techniques. See *MH-I*, Chapter 6, Handling, Packing, and Shipping Museum Objects, for general handling rules.

In addition to the general rules there are a few essential rules for the safe handling of these objects:

- Be prepared before handling these objects by having a clean area ready to receive the object. Arrange for assistance from others when necessary.
- Consider the weight of the entire object before lifting; aged and deteriorated fibers cannot tolerate much physical stress. Avoid suspending, creasing, and folding items.
- Move leather and skin artifacts on a tray support, in a drawer, or in a box; if direct handling is necessary, use both hands and support the object from underneath, not from original handles and straps.
- Accommodate the special handling requirements of appendages and decorative elements such as beadwork and dangles.
- Handle skin and hide materials only while wearing clean, cotton gloves; if hand contact is required, wash hands just before handling.

See MH-I, Appendix I, Curatorial Care of Archeological Objects, for a discussion of support trays for objects.

5. *What about catalog labeling?*

Marking and labeling leather and skin artifacts for cataloging purposes can present a number of preservation problems:

- The porous, absorbent nature of all skin products can cause labeling inks, paints and varnishes to be absorbed into the skin tissue causing irreversible staining and stiffening.
- The adhesives associated with commercial labeling tapes have poor long-term stability.
- Pressure sensitive tapes and embossed plastic tapes tend to fall off in time, and their adhesives are generally not removable from the skin.
- Any type of metal tag (including aluminum) or metal ringed tag can cause corrosion. Aluminum in contact with skin and hide materials causes dark spots on the surface of the object.

Cleaning Techniques	Tools	Caution
VACUUMING - This is the safest cleaning method, if carefully executed.	Use fine plastic screening and a vacuum cleaner with adjustable suction or a rheostat and a small standard nozzle attachment.	Screening between the leather and the nozzle protects the leather, but movement of the screen can also cause abrasion. Flaking surfaces and loose parts may be accidentally removed.
DUSTING - This is the most frequently used technique. It can be combined with vacuuming.	Use camel hair brushes.	Dust acts as an abrasive; each time a material is brushed, surface material may be removed. Brushing also increases the danger of knocking off delicate pieces.
FORCED AIR - Compressed air cleaning must be done outside the collection area or dust will simply be redistributed.	Use a compressor, air hose, and broad compressed air nozzle.	Loose or fragile pieces can be blown off if too great a pressure is used; 40 pounds/square inch is maximum.
ARTIST'S ERASER - This method can occasionally remove stubborn surface deposits from the grain side of firm, intact leathers and skins.	Use artist's block or powder eraser. (Testing has shown "Magic Rub" block and "Scum X" powder to be the least damaging.)	This technique is not useful on deteriorated surfaces or where skin or decorative layers may be susceptible to flaking. Remnants of the eraser may become deposited in textured surfaces and require vacuuming.

Figure S.5. Cleaning Techniques for Leather and Skin Objects in Good Condition

You can determine the specific labeling technique you will need by considering the individual object. Maintain consistency throughout the collection and use the least damaging method. Consider both indirect and direct labeling.

- Indirect labeling allows you to avoid irreversibly damaging the hide material with ink. The two recommended methods of indirect labeling are tie-on tags and fabric labels.
 - Make tie-on tags from high quality, acid-free paper products or inert plastic materials. Corners should not be sharp. Attach tags in a manner that does not cause undue stress, such as to an orifice, strap or handle. Use soft cotton string or a non-abrasive plastic loop for attachment.
 - If you can't label an object with a tie-on tag, use a fabric label, such as those made from cotton twill tape or non-woven spun-bonded polyester; these can be sewn to soft skin products using a beading needle and single strand, white cotton thread. You can usually attach these labels without passing completely through the skin, and you can limit stitches to the upper edge of the label. Attach at a seam or inconspicuous area of the skin or hide material, or loop to a permanent strap.
- Direct labeling on skin products can be recommended only for firm leathers and rawhide. You can apply a barrier coating or ground of clear Acryloid B-72 resin to a small, inconspicuous area

(approximately 1 cm x 3 cm in size). When dry, apply the catalog number directly. The ink should have different solubility than that of the ground resin, so it may be changed if necessary.

See NPS Conserve O Gram 1/4, Use of Acryloid B-72 Lacquer for Labeling Museum Objects and the Museum Handbook, Part II, Chapter 3, Cataloging. In addition to normal health precautions, exercise additional caution when using solvents around leather and skin products because excessive amounts can cause deterioration.

Label the object neatly in the most inconspicuous place possible. Your labels should be small yet clearly readable from a distance of one foot. Use a high quality and iron-free ink, such as India ink.

6. *How do I provide adequate physical support for objects?*

Most organic materials lose their structural integrity as they age. Collapsed, creased, or folded materials will develop local weaknesses and damage if not protected by custom mounts and supports.

Use high quality, non-reactive materials:

- rigid acrylic sheeting
- acid-free matboard and unbuffered paper tissues
- washed and undyed cotton and linen fabrics
- polyester batting
- polyethylene foam products

Attached components can cause deterioration when in contact with other materials (such as metal parts). Separate components by a barrier of polyethylene sheeting or layers of acid-free tissue.

7. *How do I store objects properly?*

Store skin and leather objects in a space that is dedicated to the storage of museum collections, where climate control and security can be adequately controlled. Although storage requirements vary somewhat for individual leather and skin materials, basic conservation principles recommend that you provide a spacious and secure storage area, appropriate cabinets and containers, an area that is as free as possible from environmental threats, and individual storage supports. See MH-I, Chapter 7, Museum Collections Storage, for guidance on storage of museum collections.

The storage needs of tanned and untanned materials can be discussed at two levels. The first level addresses the overall collections storage facility with its system of shelving, cabinets, drawers, and trays. The second level focuses on individualized object supports. The following discussion provides more guidance based on these basic principles.

- ***Provide Appropriate Cabinets and Containers***
 - Protect objects made of skin products within cabinets or on shelving with dust covers. Items should not be piled, folded, squashed or leaned. Use cabinets and storage furniture made of

metal with a baked enamel finish. Don't use wooden cabinets and shelving, because wood products emit damaging vapors.

- Use storage trays and containers to house and support individual objects as well as to reduce stress and damage during handling. Any material that directly contacts the specimen, such as boxes, tubes and tissue papers, must be of acid-free unbuffered paper. Limit your use of plastics to pure polyethylene, acrylic and polyester products.
- Vacuum and dust your storage areas regularly. Dust is acidic, abrasive and damaging to these materials. Routine and systematic housekeeping also lessens the chance of insect problems that can harm leather and skin objects.

- ***Provide Individual Storage Supports***

- You will need custom supports for many leather and skin artifacts just as you do for other sensitive organic materials. As skin products age, they become more susceptible to damage resulting from the lack of physical support. Many three-dimensional objects and most large objects (such as saddles) have additional requirements for either internal or external reinforcement.

Individual supports shouldn't constrict or interfere with the expansion and contraction of the skin materials, restrict the gain and release of moisture as the hide responds to environmental changes, be permanently attached to the object, or provide harborage for damaging insect pests.

- Use supports to provide specific reinforcement to all vulnerable areas that are prone to damage under the object's own weight or because of the limitations of the storage container. Disfigurement and folding of skin materials frequently leads to permanent deformity, the straining of fibers and eventual cracking.
- The design and materials (see page 16, item 6) you will use in your supports depends on the shape, weight and needs of the individual object. For instance, you can roll flat hides and robes around large diameter (minimum of 6" diameter) tubes. Store garments flat and stuffed with a light weight support to eliminate creasing. Place saddles on a rigid saddle tree or dummy support if fenders are likely to become deformed. See Figure S.6 for an illustration of how to construct a saddle mount.
- Hide objects can deteriorate because of poorly selected and inappropriate support materials. Harmful materials are those that emit damaging vapors and organic compounds.

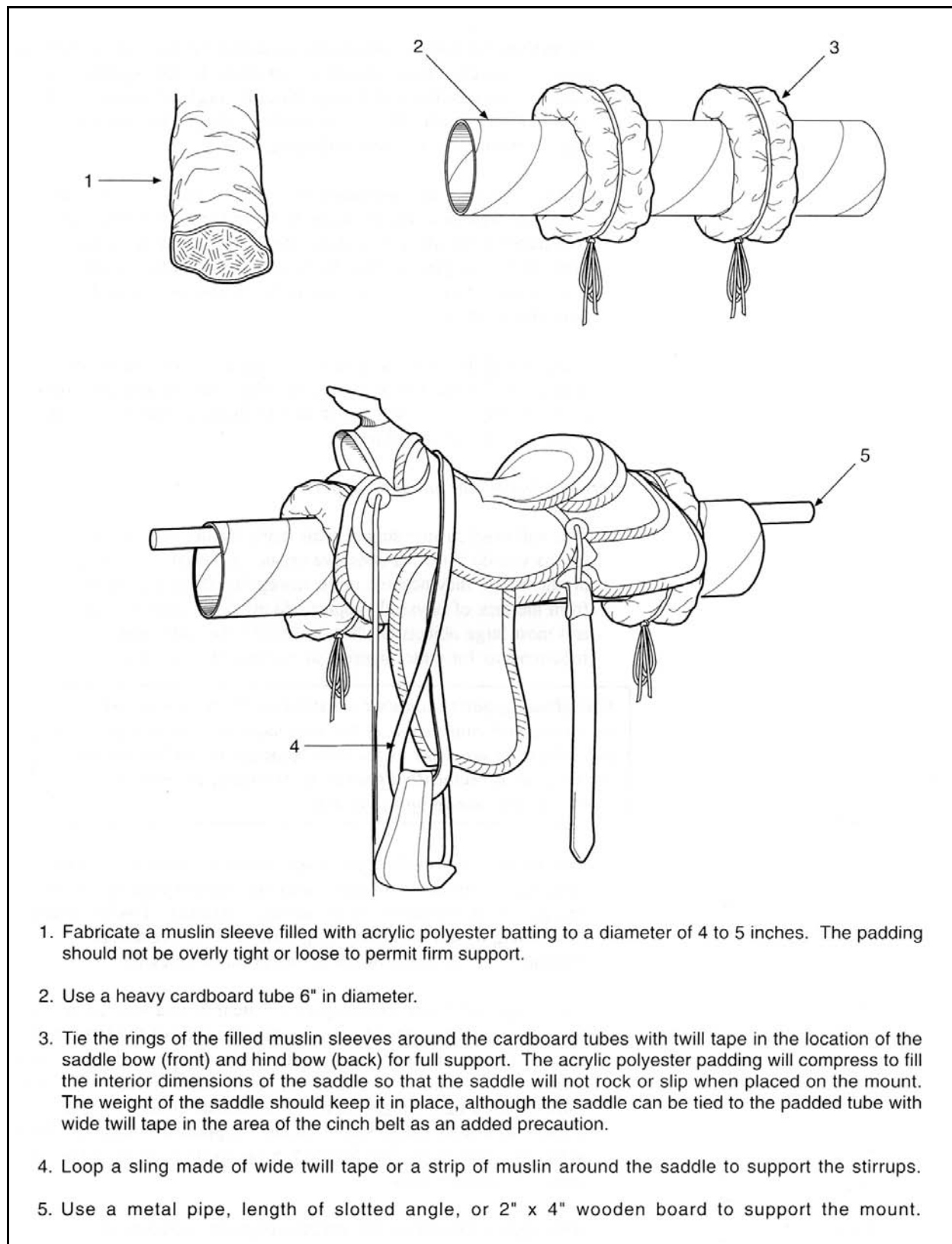

Figure S.6. Constructing a Saddlemount

E. Summary: Leather and Skin Product Deterioration and Preventive Care

The previous two sections discussed deterioration, the causes of deterioration, and ways to limit deterioration through preventive conservation efforts. Figure S.7 summarizes some of this information.

CONDITION	PROBABLE CAUSE	PREVENTIVE ACTION
Deformation (contraction, cockling, cupping, shrinkage)	Physical alteration during use, storage or exhibition	Support in unconfined space
	Desiccation	Raise & stabilize ambient RH
	Alternate wetting or drying	Use container to protect against humidity extremes
	Excessive heating	Lower ambient temperature
	Photochemical reaction	Filter UV radiation, lower visible light
Embrittlement (rigid, inflexible, brittle)	Disuse, absence of flexing	None available
	Desiccation	Raise and stabilize ambient RH
	Soil impregnation	Use container, filter air
	Deterioration, loss of fat	Filter UV radiation, lower visible light
	Detanning	Use container
	Photochemical reaction	Filter UV radiation, lower visible light
Low cohesive strength (weakened, powdering, separating, fibrous)	Poor manufacture	None available
	Mechanical abuse	Use container, eliminate handling
	Chemical air pollution	Use container, filter air
	High acidity	Use container, filter air, stabilize ambient RH
	Oxidation	None available
	Loss of fat or water content	Stabilize ambient RH
	Photochemical reaction	Filter UV radiation, lower visible light
Physical Damage (abrasion, tearing, splitting, holes, missing parts, disjoined section)	Historic usage	Support, limit handling
	Inherent stress	Support, limit handling
	Dimensional movement	Stabilize ambient RH
	Handling	Use container, limit handling
	Stitching failure	Use container, limit handling
	Adhesive failure	Use container, limit handling
	Biological attack	Inspect, initiate control program
Soil or stain accumulation (oiliness, water staining)	Use during historical period	Document, identify using remaining characteristics
	Improper handling	Instruct staff in proper handling, limit handling
	Unprotected storage or display	Use container, filter air
	Unstable fat spew formation	Stabilize ambient temperature
Discoloration (fading, darkening, lightening)	Soiling or staining	Use container, filter air
	Excessive fat content	None available
	Acid deterioration	Use container, filter air
	Photochemical reaction	Filter UV radiation, lower visible light
Loss of grain layer or exterior surface	Morphological feature of skin	Use container, limit handling
	Poor manufacture	Use container, limit handling
	Mechanical abuse	Limit handling
	Uneven consolidation	None available
Loss of fur or hair (slippage, breakage)	Morphological feature of hair	Use container, limit handling
	Poor manufacture	Use container, limit handling
	Desiccation	Stabilize RH
	Insect attack	Initiate periodic inspection and control program

Figure S.7. Leather and Skin Product Deterioration and Preventive Care

F. Conservation Treatment Issues

Curators, collectors, and conservators alike have been guilty of relying on old treatments to preserve skin materials, and far too frequently they accepted the promotions of commercial products designed for contemporary leathers. This history of haphazard treatment and unsystematic evaluation of skin products has resulted in considerable damage and loss. Common criticisms of past treatments of skin and leather products are that preservation attempts have not differentiated among the distinct categories of skin materials and have relied too heavily on the application of "preservatives."

The traditional remedies and reagents once routinely used in museum collections are now being carefully scrutinized by museum conservators. With the aid of scientific investigation and the assessment of the results of past treatment, several important new directions are being taken. The findings on past treatments have not been encouraging.

The routine application of preservatives (such as saddle soaps and leather dressings) is discouraged.

1. *What are the perils of saddle soap?*

There are many problems associated with the use of "saddle soap" on historic and artistic objects made from animal skin products. With the best of intentions, this commercial product has been inappropriately applied to just about every form of skin material in the past.

"Saddle soap" was not developed as a cleaner, but as a 19th century leather conditioner. Its basic components of neatsfoot oil and cod or sperm oil were emulsified with soap in water to produce an emulsion fat-liquor introduced during early tanning. As a conditioner, saddle soap is considered obsolete by tanners today.

Its application has caused considerable permanent damage to skin and leather objects since its components cannot be easily rinsed out and adequately removed (as manufacturer instructions often suggest). Saddle soap effectively softens and emulsifies surface oil and dirt, however it usually distributes them deeper into the material. The mixture's high moisture content presents a hazard to aged skin materials that should not be wetted, as well as light colored vegetable and/or alum tanned leathers.

Commercial formulations of saddle soap differ in their ingredients, some containing abrasives and even colorants. Saddle soap quality fluctuates greatly among manufacturers.

Perhaps most importantly, conservators now suspect that the surface cracking on many older skin and leather objects may well be due to past "saddle soap" application. Avoid it.

2. *What are the drawbacks of leather dressings?*

The care of skin and leather goods has traditionally involved the routine use of leather dressings, solutions of fats and oils that lubricate skin products to increase flexibility. Modern research has shown, however, that the haphazard use of dressings has been the cause of considerable deterioration within museum collections.

These solutions should never be applied to Native-tanned materials or objects comprised of untanned or semi-tanned skin products. Avoid the use of leather dressings on museum objects.

Numerous drawbacks are associated with dressing of skin products. For example, dressings frequently:

- darken lighter colored leathers
- encourage biological attack
- form fatty spews at the surface
- oxidize over time and stiffen the material
- wick into surrounding materials
- soften original finishes and decoration
- cause dust to accumulate
- impede future conservation treatment
- contaminate the material for future analysis

3. *What about neutralization of acids?*

The chemical decay and disintegration of leather resulting from exposure to acids is a well-known problem and its solution for older leathers remains unresolved. Vegetable-tanned leathers produced since the mid-19th century frequently exhibit a condition of internal fiber degradation known as "red rot." The color of the leather actually reddens as the deterioration progresses. In its advanced state, affected leather will disintegrate into a powdery form.

This condition is most always associated with sulfuric acid, introduced either during the tanning process or from atmospheric contact with the contaminant sulphur dioxide. (Leather readily absorbs acid from the air.) Sulphur dioxide, when absorbed, becomes sulphur trioxide, which unites with water to form sulfuric acid, resulting in a devastating effect on collagen fibers. Certain vegetable tannages (the ones categorized as condensed tannins) have been identified as being much more susceptible to this mechanism of deterioration.

Modern leathers are fortified against acid formation by incorporating buffering salts that repress acid formation and action. Some of the museum preservation literature during the last decade recommended that older leathers be treated with similar buffering salts, such as potassium lactate and potassium citrate, to protect them from acid attack.

The problem that museum curators face is that there is no easy and safe method for long-term neutralization of acids that are present in historic leather objects. There are three drawbacks associated with the treatment of leather with standard buffering salt solutions:

- The salts must be introduced in an aqueous solution yet water can be very damaging to historic leather causing stiffening, color change and disruption of applied finishes.
- Salt solutions are meant only for vegetable-tanned leather and will de-tan and damage mineral-tanned materials; the applicator must, therefore, be able to distinguish between them, which is not an easy task.
- The addition of buffering salts will do nothing for leathers that have already begun to deteriorate from acid exposure.

The conservation field is looking at other methods of deacidifying leathers; vapor phase reagents and non-aqueous chemicals are being investigated. The importance of this conservation issue is clear to those involved, and acceptable procedures should be available to museum staffs in the near future.

G. Selected Bibliography

- Canadian Conservation Institute. *Leather Skin and Fur*, CCI-ICC Notes, No. 1-4 (Notes on Curatorial Care). Ottawa, Canada: Canadian Conservation Institute, 1986.
- Fogle, Sonja, Toby Raphael and Katherine Singley. *Recent Advances in Leather Conservation*. Washington, DC: Foundation of the American Institute for Conservation, 1985.
- Haines, Betty. *The Conservation of Bookbinding Leather, A Report by the British Leather Manufacturers' Research Association for the British Library*. The British Library, Great Russell Street, London, England WC1B 3DG, 1984.
- _____. *Monograph Series on Leather*. The Leather Conservation Center Ltd., 34 Guildhall Road, Northampton, England NM1 1EW, 1991.
- Krahn, Ann Howatt. "Conservation: Skin and Native-Tanned Leather." *American Indian Art Magazine* (Spring), 1987.
- Nathanson, David, and Diane Vogt-O'Connor. "Care and Security of Rare Books." *Conserve O Gram* 19/2. Washington, DC: National Park Service, Curatorial Services Division, 1993.
- Raphael, Toby, and Ellen McCrady. "Leather Dressing: To Dress or Not To Dress." *Conserve O Gram* 9/1. Washington, DC: National Park Service, Curatorial Services Division, 1993.
- _____. *Ethnographic Skin and Leather Products: A Call for Conservative Treatment*. Published Proceedings of Symposium '86: The Care and Preservation of Ethnological Materials. Ottawa, Canada: Canadian Conservation Institute, 1986.
- Raphael, Toby. "Preventive Conservation Recommendations for Organic Objects." *Conserve O Gram* 1/3. Washington, DC: National Park Service, Curatorial Services Division, 1993.
- _____. "An Insect Pest Control Procedure: The Freezing Process." *Conserve O Gram* 3/6. Washington, DC: National Park Service, Curatorial Services Division, 1994.
- Reed, R. *Ancient Skins, Parchments and Leathers*. London: Seminar Press, 1972.

- Stambolov, T. *Manufacture, Deterioration and Preservation of Leather: A Literature Survey of Theoretical Aspects and Ancient Techniques*. ICOM, Amsterdam: Central Research Laboratory, 1969.
- Storch, Paul (Editor). *Leather Conservation News*, Objects Conservation Laboratory, Minnesota History Center, 345 Kellogg Boulevard, West St. Paul, MN 55102-1906.
- Sullivan, Brigid and Donald R. Cumberland, Jr. "Use of Acryloid B-72 for Labeling Museum Objects." *Conserve O Gram* 1/4. Washington, DC: National Park Service, Curatorial Services Division, 1993.
- Waterer, John. *A Guide to the Conservation and Restoration of Objects Made Wholly or in Part of Leather*. New York, NY: Drake Publishers Inc., 1972.

Appendix T: Curatorial Care of Biological Collections

Page

Section I: The Nature of Biological Collections	T:1
A. Overview	T:1
What information will I find in this appendix?	T:1
What are biological collections?	T:1
B. Introduction to Biological Collections	T:1
What types of specimens are included in biological collections?	T:1
What is the value of biological collections?	T:4
What is the basis for collecting appropriate specimens?	T:5
How are biological collections used?	T:5
Does preservation method affect use?	T:6
How should I manage biological collections?	T:6
What is involved with the proper care of biological collections?	T:7
What are the agents of deterioration that affect biological collections?	T:7
What should I know about preventive conservation of biological collections?	T:8
How should I handle biological specimens?	T:8
Are there any other handling issues that I should be aware of?	T:10
Are there any health and safety concerns related to biological collections?	T:10
Section II: Preservation of Biological Collections In General	T:13
A. Overview	T:13
B. Stabilization of Biological Specimens	T:13
What is stabilization?	T:13
What issues should I consider prior to stabilization?	T:13
What issues should I consider once we decide to initiate stabilization of specimens?	T:14
What information should I document during stabilization of biological specimens?	T:14
Are there any other issues related to stabilization that I should consider?	T:16
What protection concerns and practices are involved with stabilization of biological specimens?	T:16
What health and safety concerns should I be aware of during stabilization?	T:16
C. Processing of Biological Specimens	T:17
What is processing?	T:17
What are the NPS requirements for processing of project-generated specimens?	T:17
What is involved in preparation of specimens?	T:18
What is involved in accessioning biological specimens?	T:18
What is involved in cataloging biological specimens?	T:19
How should I label specimens?	T:19
What materials should I use to label specimens?	T:20
How should I handle biological specimens during processing?	T:22
What should I know about preparation materials?	T:23
How should I document a specimen's condition during processing?	T:23
Are there any special health and safety concerns during processing?	T:23
What do I need to know about loans of specimens?	T:23
What techniques should I use when packing and shipping specimens for loans?	T:25
What are the regulations pertaining to shipments of hazardous specimens?	T:25

D. Storage of Biological Collections	T:26
How should I store biological collections?	T:26
Where should I locate storage?	T:27
How can I ensure the security of biological collections in storage?	T:27
How should I organize my park's biological collection?	T:28
What about other methods of arrangement?	T:28
Are there any other issues related to collection arrangement that I should consider?	T:29
What issues should I consider when planning a new or upgraded storage facility for biological specimens?	T:29
What storage systems will best protect my park's biological collections?	T:32
What types of storage equipment should I use for biological collections?	T:35
What special concerns should I consider when installing new storage equipment?	T:37
What types of storage materials are appropriate for use with biological collections?	T:38
Are there any cautions to using the above materials with biological specimens?	T:39
What materials should not be used for storage of biological specimens?	T:39
E. Maintenance of Biological Collections	T:40
What is maintenance?	T:40
What information management issues are related to maintenance of biological collections?	T:41
How important is housekeeping for biological collections?	T:41
What housekeeping strategies should I use for long-term preservation of biological specimens?	T:41
What should I know about emergency management, response and recovery?	T:42
What do I need to know about salvaging biological specimens following an emergency?	T:42
What about cleaning biological specimens?	T:43
Are there any other concerns regarding treatments of biological specimens?	T:44
Are there any health and safety concerns related to maintenance of biological collections?	T:44
Should I document cleaning, treatment, and salvage activities?	T:44
How can I protect biological specimens from pests?	T:44
Section III: Dry Biological Collections	T:46
A. Overview	T:46
What are dry biological collections?	T:46
Why are some biological specimens preserved in a dry state?	T:46
What types of biological specimens are usually included in dry collections?	T:46
What are the primary agents of deterioration that affect dry collections?	T:47
How does neglect affect dry collections?	T:47
How do pests threaten dry collections?	T:47
How can contaminants adversely affect dry collections?	T:47
How does visible and ultraviolet light affect dry collections?	T:49
How does temperature and relative humidity affect dry collections?	T:49
Are there any special rules for handling dry collections?	T:50
What security issues are related to dry collections?	T:53
Are there any health and safety concerns associated with dry collections?	T:54
B. Special Concerns for the Stabilization of Dry Specimens	T:55
How are dry specimens stabilized?	T:55
What protection concerns and practices are involved with stabilization of dry specimens?	T:55
C. Special Concerns for the Processing of Dry Biological Specimens	T:56
Are there any general observations about processing of dry specimens?	T:56
What are the agents of deterioration that affect dry collections during processing?	T:57

D.	Special Maintenance Concerns for Dry Collections	T:57
	What should I do about migrating lipids that are staining the specimen or surrounding materials?.....	T:57
	How should I protect dry specimens from pests?	T:58
	What passive IPM measures should I take to protect the collection?	T:58
	What active IPM measures should I take to protect the collection?	T:59
	What should I do if eradication is necessary?	T:60
	What kind of traps can I use?	T:61
	Are there any cautions related to traps that I should consider?.....	T:62
	How can I use freezing temperatures to eliminate a pest problem?	T:62
	How can I use heat to eliminate a pest problem?	T:63
	How can I use a low-oxygen environment to treat a pest problem?	T:63
	If necessary, can I still use chemical treatments to eliminate a pest problem?.....	T:63
	Where can I find additional information concerning IPM and pest control?	T:63
	Section IV: Wet Biological Collections	T:64
A.	Overview	T:64
	What are wet collections?.....	T:64
	Why are these specimens preserved in a wet form?.....	T:64
	What is fixation?	T:64
	Are all wet specimens treated with a fixative?	T:64
	What types of preservative fluids are used for wet collections?	T:64
	What types of specimens are usually included in wet collections?.....	T:64
	What are the primary agents of deterioration for wet collections?.....	T:65
	How can inappropriate temperature and temperature fluctuations adversely affect wet collections?	T:66
	Can relative humidity adversely affect wet collections?.....	T:66
	How can wet collections become contaminated?	T:66
	Are there any special health and safety concerns related to wet collections?	T:67
B.	Stabilization of Wet Biological Specimens	T:68
	What specimen characteristics should I document prior to stabilizing a wet specimen?	T:68
	What should I know about the stabilization process for wet specimens?	T:68
	Is formalin used with all wet biological specimens?	T:69
	How do I protect specimens during stabilization?	T:69
	What are the health and safety issues concerning stabilization of wet specimens?.....	T:70
C.	Processing of Wet Biological Specimens	T:71
	What general information about processing should I be aware of?.....	T:71
	How should I label wet specimens?.....	T:72
	What materials should I use to label wet specimens?.....	T:72
	What agents of deterioration affect wet biological specimens during processing?.....	T:73
	How should I handle wet biological specimens during processing?	T:74
	Can I keep some wet biological specimens in formalin?	T:75
	How do I transfer wet specimens from formalin to an alcohol solution?.....	T:75
	Can I transfer wet biological specimens from ethanol to isopropanol?	T:77
	What about clearing and staining specimens?	T:77
	Can I keep different wet biological specimens together in the same container?	T:77
	How should I document a wet specimen's condition during processing?.....	T:77
	What health and safety concerns should I be aware of during processing?.....	T:78
	What do I need to know about loans of wet specimens?	T:78
D.	Storage of Wet Biological Collections	T:79
	Where should I locate storage?	T:79

What agents of deterioration pose the greatest threat to wet collections in storage?	T:79
Are there any special considerations for storing wet specimens?	T:80
What types of storage containers should I use?	T:82
Are there any other storage requirements that I should consider?	T:84
What about arranging wet specimens?.....	T:84
Are there any special health and safety concerns related to storage of wet collections?	T:85

E. Maintenance of Wet Biological Collections	T:85
What does maintenance of wet collections include?	T:85
How do I maintain fluid quality for wet specimens?.....	T:85
How are fluids lost or compromised?.....	T:86
How do I replace or replenish the fluid preservative?.....	T:87
Are there any other ways to adjust fluid concentrations?.....	T:88
When should I replace the fluid?.....	T:88
Should I be concerned if some fluids are discolored?	T:88
When should I consult a conservator?	T:89
Are there any health and safety concerns related to maintenance of wet collections?	T:89
What should I know about emergency preparedness, response, salvage, and long-term recovery?	T:89
Do I need to document maintenance activities such as replacing fluids?.....	T:90

Section V: Biological Low-Temperature Collections..... T:91

A. Overview	T:91
Why are specimens preserved at low temperatures?.....	T:91
What low temperatures are used?.....	T:91
What specimens are preserved at low temperatures?	T:91
What agents of deterioration affect low-temperature collections?	T:93
What health and safety concerns are related to low-temperature collections?	T:94
B. Stabilization and Processing of Low-Temperature Collections	T:95
How should I label low-temperature collections?.....	T:96
What should I know about loans of low-temperature collections?	T:97
What agents of deterioration affect low-temperature collections during processing?	T:97
How should I handle specimens during processing?	T:98
How should I pack and ship specimens for loans?	T:99
How should I document a specimen's condition during processing?	T:99
What health and safety concerns should I be aware of during processing?.....	T:100
C. Storage of Low-temperature Collections	T:100
Are there any special storage considerations concerning low-temperature collections?	T:100
How should I organize low-temperature collections?	T:100
What are the primary agents of deterioration that affect specimens in storage?.....	T:101
What special features should I include in low-temperature storage areas?.....	T:102
What types of supplies and equipment are used for storage of low-temperature collections?	T:103
What else should I know about mechanical freezers?.....	T:105
How should I store specimens inside a freezer?.....	T:105
What about storage of DNA samples?.....	T:106
Are there any special health and safety concerns related to storage of low-temperature collections?	T:106
D. Maintenance of Low-temperature Collections	T:107
Are there any special maintenance issues concerning storage of low-temperature collections?.....	T:107
What is involved in salvage of low-temperature collections?	T:108

What is the “best method” of salvage?	T:108
Where can I get salvage advice and assistance?	T:110
How should I document emergency salvage efforts?	T:110
Section VI: Biological Microscopy Collections	T:111
A. Overview	T:111
Why are some specimens preserved as microscope preparations?	T:111
How are specimens preserved as microscope preparations?	T:111
What agents of deterioration affect microscopy collections?	T:112
Are there any health and safety concerns related to microscopy collections?	T:114
B. Stabilization and Processing of Microscopy Collections	T:116
What are the primary agents of deterioration that affect microscopy collections?	T:116
How should I handle specimens during processing?	T:117
How should I label microscope slides?	T:117
What types of specimen containers should I use for microscopy preparations?	T:117
How should I pack and ship microscopy specimens for loans?	T:117
How should I document a specimen’s condition during processing?	T:118
C. Storage of Microscopy Collections	T:118
How should I organize the collection?	T:118
What are the primary agents of deterioration for microscopy collections in storage?	T:119
What are the appropriate environmental conditions for storage of microscopy collections?	T:120
What types of storage equipment should I use?	T:120
Are there any common problems with microscopy collections?	T:121
What should I do if specimens need to be cleaned, remounted, or treated?	T:121
What should I know about salvaging microscopy collections?	T:121
Are there any health and safety issues that I should consider?	T:122
Section VII: Glossary	T:123
Section VIII: References	T:124
Section IX: Non-NPS Repositories with Servicewide or Multi-Regional Agreements to House Park Biological Collections	T:134
List of Figures	
Figure T.1 Use extra care when transporting specimens with delicate parts.	T:9
Figure T.2 Microscope slides stored horizontally in a slide cabinet	T:121

APPENDIX T: CURATORIAL CARE OF BIOLOGICAL COLLECTIONS

SECTION I: THE NATURE OF BIOLOGICAL COLLECTIONS

A. Overview

1. *What information will I find in this appendix?*

This appendix discusses the nature of biological collections and outlines strategies for their long-term care and preservation.

Most biological collections are either dry collections or wet collections. They also may include collections preserved at low temperatures or microscopy collections. This appendix discusses all four types of biological collections. It also includes the four basic stages of preservation: stabilization, processing, storage, and maintenance.

2. *What are biological collections?*

Biological collections are typically:

- preserved plant or animal specimens
- specimen documentation, such as labels and notations (**Note:** associated project data, reports, notes, etc. should be accessioned into the park's archives and cross-referenced to the related specimens)

Normally biological materials are maintained as separate collections based on:

- the types of specimens
- the type of preservation
- differences related to management, care, and use

Plants would be a part of a plant collection, but depending on the size and diversity of the collection, it might be appropriate to differentiate types of plants, and include a vascular plant collection and a non-vascular plant collection.

B. Introduction to Biological Collections

1. *What types of specimens are included in biological collections?*

Common biological collections include non-vascular and vascular plants, and animals, both vertebrate and invertebrate. See Table T.1 for a listing of common biological collections and their phylogenetic relationships to one another.

Plants		Animals	
<p>Non-vascular Plants</p> <ul style="list-style-type: none"> • Aquatic <ul style="list-style-type: none"> - algae • Terrestrial <ul style="list-style-type: none"> - fungi - lichens - mosses 	<p>Vascular Plants</p> <ul style="list-style-type: none"> • Gymnosperms <ul style="list-style-type: none"> - conifers • Angiosperms <ul style="list-style-type: none"> - flowering plants 	<p>Invertebrates</p> <ul style="list-style-type: none"> • Porifera <ul style="list-style-type: none"> - sponges • Cnidaria <ul style="list-style-type: none"> - jellyfishes - corals, sea fans, anemones • Ctenophora <ul style="list-style-type: none"> - comb jellies • "Vermes" <ul style="list-style-type: none"> - various phyla of worms and leeches • Arthropoda <ul style="list-style-type: none"> - crustaceans - spiders and mites - horseshoe-crabs - insects - centipedes and millipedes • Mollusca <ul style="list-style-type: none"> - snails, slugs, abalones - clams - squid, octopuses, nautilus • Echinodermata <ul style="list-style-type: none"> - sand/sea stars - brittle stars - sea urchins - sea cucumbers - sea daisies - sea lilies and feather stars 	<p>Vertebrates</p> <ul style="list-style-type: none"> • Fish • Amphibians and Reptiles • Birds • Mammals

Table T.1. Common biological collections and their phylogenetic relationships to one another

Table T.1 lists the most common types of biological collections. Your collection may include more specialized collections such as parasites, butterflies, or beetles. Table T.1 does not include specimens from other kingdoms of living things, such as bacteria and amoebas. Nor does it cover all known phyla of plants and animals. Other objects or specimen parts also may be included in various specialty collections (see Table T.2.).

Note: Most specimen parts and related archives have little relevance unless they are linked to a voucher specimen with sufficient characteristics to permit identification using the techniques of classical taxonomy.

	Macroscopic material	Microscopic material, including SEM stubs)	Replicas (casts, molds, and models)	Specimen documentation (in addition to accession, catalog, and loan records)
Plants	Wood samples, tree rings, large seeds or fruits, exsiccati (usually collections of specimens in bound volumes), economic botany samples such as cultivars	Pollen, very small seeds, dissected parts	Models in wax, glass, synthetic polymers etc.; molds	Primary labels and annotation labels Place all project documentation in the park archives: field records; notes and manuscripts; permits; original art work; images (photographic, digital, video, film.
Invertebrates	Larvae, dissected organs or other tissues, freeze-dried specimens, eggs, pupae	Dissected organs or other tissues; some whole organisms (larvae, shell ultrastructures)	Models in wax, glass, synthetic polymers; molds; some larvae	Specimen labels Place all project documentation in the park archives.
Fish	Taxidermy preparations, gut contents, eggs, larvae, fin clips, freeze-dried specimens, cleared and stained specimens, frozen tissues	Scales, otoliths	Casts or models in plaster, synthetic polymers, etc.; molds	Field identification tags and specimen labels. Place all project documentation in the park archives.
Amphibians & Reptiles	Nests, eggs, taxidermy preparations, cleared and stained specimens, skeletons, dry or tanned skins, gut contents, larvae, frozen tissues, freeze-dried specimens	Internal and external parasites	Casts or models in plaster, synthetic polymers, etc.; molds	Field identification tags and specimen labels Place all project documentation in the park archives.
Birds	Scats, eggs, nests, spread wings, taxidermy preparations, skeletons, complete or partial dioramas, samples of feathers, feet and bills, some large parasites, gut contents, embryos, frozen tissues, freeze-dried specimens, naturally mummified specimens	Internal and external parasites	Casts or models of whole specimens or tracks in plaster, synthetic polymers, etc.; molds	Specimen labels and leg bands Place all project documentation in the park archives.

Table T.2. Specimen parts and other materials included with voucher specimens in a collection.

Mammals	Scats, eggs, nests, taxidermy preparations, skeletons, complete or partial dioramas, naturally mummified specimens,	Internal and external parasites, hair samples, baculi, phalli, karyotypes	Casts or models of whole specimens or tracks in plaster, synthetic polymers, etc.; molds	Field identification tags, specimen labels, and ear tags Place all project
----------------	---	---	--	---

	tanned skins, horns and antlers, gut contents, dissected organs, embryos, frozen tissues, freeze-dried specimens or specimen parts, sectioned teeth, some dissected baculi; some large parasites			documentation in the park archives.
--	--	--	--	-------------------------------------

Table T.2. Specimen parts and other materials included with voucher specimens in a collection (continued)

Biological collections may be grouped within broad taxonomic categories according to the nature of preservation. Biological specimens normally are preserved by drying, preservative fluids (either as macroscopic or microscopic preparations), or storage at low temperatures.

2. *What is the value of biological collections?*

Biological collections are valuable (in order of rank) as:

- types (specimens referred to in the first published account of a new taxonomic group)
- rare, endangered or extinct species
- vouchers for specific research studies or specimens of special historical value
- specimens rarely found in any collections or those that are rare in the particular collection in question
- specimens that fully document the existence of a species at a given place and time (most properly collected and maintained biological specimens will fit this category)
- specimens collected specifically for destructive sampling or for interpretive programs

Some specimens fall into more than one of these categories.

The most common uses of biological collections are to resolve issues related to taxonomic identification and provide physical evidence of the presence of a particular taxon at a specific place and point in time.

3. *What is the basis for collecting appropriate specimens?*

Before you can understand if a particular specimen is appropriate in a collection, you first must understand its value. You also need to know how the specimen might be handled and used. Cultural value, usually for historical or scientific purposes, is the basis for responsibly selecting material for biological collections.

Note: Many historical specimens were not necessarily collected to answer a

specific research question, as specimens collected for scientific purposes today are. However, if historic specimen collections do include adequate documentation, (detailing the existence of a taxon at a place and point in time), they are scientific collections too.

Collecting based on emotional values can result in collection biases and inappropriate commitments for the collection. Examples of collecting for emotional value may include:

- the acquisition of particularly attractive or unusual specimens
- some salvage operations

Collecting for use often assumes eventual destruction or transfer of the specimen in question. For responsible resource management, you must evaluate:

- the level of initial preparation that a specimen needs for placement in the collection
- the amount of long-term management and care required for such specimens once placed in the collection

For instance, a taxidermy mount of a commonly occurring animal, which lacks collecting, preparation, and provenience data, has little purpose other than exhibition or teaching. It may not be appropriate to allocate resources for long-term management and care of such a specimen.

4. *How are biological collections used?*

Collection use is dependent on many factors, such as the specimens or parts available, expertise available, preservation methods, and preservation quality. The use of most collections falls into specific categories, which vary according to the number of specimens involved. For instance, a single specimen can be used for:

- a voucher of research
- a synoptic reference sample
- documentation of the occurrence of a species at a given place and time
- interpretation

As the number of specimens of a given species increases, the types of use expand substantially. Besides the uses noted above, the collection can document:

- variations
 - among individuals
 - among age groups
 - between sexes
- seasonal variation
- geographical variation

- geographical distribution
- ecological relationships and associations

Remember: The basic reason for maintaining biological collections is to promote their use in both science and education.

5. *Does preservation method affect use?*

Yes, the method of specimen preservation has an impact on collection use.

Dry preservation is useful for visual examination of characteristics, particularly where a degree of color and some delicate parts are important.

Fluid preservation may sacrifice color, but is useful for preserving internal organs that might be exposed by dissection.

Because there is no single preservation method that will accommodate all possible uses of a specimen, a collection often includes specimens preserved by different methods.

Many of the modern research uses for biological collections involve very specialized preservation methods and materials. These include:

- histology
- parasitology
- chemical or biochemical analyses
- molecular genetics
- analyses of environmental pollutants

These uses require appropriate research personnel, facilities, and equipment. Many institutions with collections lack the expertise to carry out or even to properly evaluate requests for these kinds of fairly sophisticated research. Such institutions also can rarely provide appropriate care for the materials generated by the research.

6. *How should I manage biological collections?*

Manage collections to ensure that they are available for use. When you decide to preserve a specimen, you should:

- utilize appropriate processing methods. Such methods must comply with standard practices appropriate to the type of biological materials. This will ensure the quality and integrity of:
 - the specimen
 - associated information
- organize the specimens (with hundreds, perhaps thousands, of others) in an established order

- this facilitates retrieval of specimens

- use storage equipment and supplies that best serve the goals of preservation and access

Your management responsibilities also include:

- updating the organization of the collection
- directing collection growth as scientific research changes

7. *What is involved with the proper care of biological collections?*

To provide proper care, document and use the best:

- preservation methods
- preservation materials
- collection environments
- handling practices
- storage designs
- emergency salvage and response procedures
- condition reporting
- collection treatments

When you practice proper collections management and care, your collections will be accessible, useful, and stable. Remember to incorporate management and care concerns in the development of all recommended policies and procedures.

8. *What are the agents of deterioration that affect biological collections?*

Biological materials are designed to decompose. They can be damaged by any of the following processes:

- Mechanical
- Biological
- Chemical

Remember: Damage from one process can sometimes cause another. The specific agents of deterioration that affect biological collections are:

- visible and ultraviolet (UV) light
- inappropriate temperature
- inappropriate relative humidity levels and fluctuations (especially at extreme levels)
- contaminants or pollutants

- pests
- fire
- water
- physical forces
- criminal activity
- neglect

All of these agents may act on biological specimens. The risk of one agent over another may vary considerably, depending on the type of preservation or collection.

9. *What should I know about preventive conservation of biological collections?*

Biological collections have research potential. New and innovative technological approaches to research are common. Avoid any action that might compromise the research integrity of the specimens. For this reason, your response to threats of mechanical, biological, or chemical damage should **emphasize stabilization before interventive treatments**.

10. *How should I handle biological specimens?*

Some specimens may have special handling requirements. Discuss these issues with the researcher who collected and/or prepared the specimens. Contact your regional/SO curator or the Senior Curator of Natural History if you have any questions.

In general, handle specimens as you would other museum objects:

- Handle specimens as infrequently as possible.
- Handle each specimen as though it's irreplaceable and the most specimen valuable in the collection.
- Never smoke, eat, or drink while handling specimens.
- Don't wear anything that may damage the specimen. To avoid scratching and snagging surfaces, be careful of breast pocket contents, jewelry, watches, and belt buckles.
- Use only a pencil when examining specimens.
- Save all information that is associated with the specimen, such as tags and labels.
- Know the condition of a specimen before moving it.
- Lift and/or move the specimen by supporting its strongest structural component. Do not lift it by protruding parts, small bones, wings, or attachments. These areas are weak. They also can be easily separated from the rest of the specimen (and lost!).
- Use a utility cart with padded shelves and raised sides to transport specimens from one room, area, or building to another. See *Tools of the Trade* for additional information.

- Handle only one specimen at a time and use both hands. Use one hand for support and the other hand for balance.
- If you transport a specimen via a specimen tray, be sure that it cannot shift or fall out. Use cavity packing (see Appendix I, Figure I.6., page I:11) to keep specimens from shifting.
- If you need to temporarily place a specimen in an unstable position for examination, be sure to support it. Exercise extreme caution in these situations. Return the specimen to a stable base or surface as soon as possible.
- Never hurry when handling specimens. Move slowly.



Figure T.1. Use extra care when transporting specimens with delicate parts, such as this pinned butterfly specimen. Photograph courtesy of the Bohart Museum of Entomology, University of California, Davis.

If part of a specimen is broken, reattach it as soon as possible to prevent it from becoming separated or lost. At a minimum, place the broken part in a labeled polyethylene bag or acid-free (not buffered) envelope to ensure that it doesn't become lost. Consult with your regional/SO curator, the Senior Curator of Natural History, or a natural history conservator for advice.

11. *Are there any other handling issues that I should be aware of?*

Researchers will need to handle specimens in order to study them. But don't assume that everyone who requests collections access (including scientists) is aware of all the proper handling procedures.

Be sure that you:

- know how to appropriately handle all of the specimens in your collection.
- thoroughly brief all collections users on proper specimen handling techniques. A good way to do this is to provide all researchers with a copy of your park's "Collections Handling Guidelines."
- require all collections users to sign a statement agreeing to abide by these and any other applicable rules, as a condition of access.

For additional information, refer to Chapter 6: Handling, Packing, and Shipping. You also may find the following example standard operating procedures to be useful:

- Figure 6.14, "Example of Written Handling Rules for NPS Collections" on page 6:30
- Figure G.6., "Sample Visitor Log" on page G:32
- Figure G.7., "Conditions for Access to Museum Collections" on page G:33

12. *Are there any health and safety concerns related to biological collections?*

The collection, preparation, and handling of biological specimens can pose various risks to human health and safety. One of the most familiar concerns is the historic use of toxic chemicals, such as arsenic, for preservation and pest control. These collections may involve other risks as well.

Collecting living organisms can be dangerous because of:

- the organisms' natural defense systems, such as:
 - marine organisms that sting (jellyfish, stingrays, sea urchins, octopuses, and others)
 - venom in snakes
- non-target species in the same habitat.

Even after collection, be sure to handle all organisms with care. Natural toxins in the plant or animal and diseases can be transferred to humans from an animal or its parasites. Health hazards include:

Bacterial Diseases

- Anthrax (hoofed animals)
- Bucellosis (cattle, goats, hares, pigs)
- Erysipelas (pigs, marine mammals, possibly birds)
- Leptospirosis (rodents, hares, hedgehogs, possibly others)
- Plague (rodents)

- Pseudotuberculosis (birds, some rodents and possibly other small animals)
- Psittacosis/ornithosis (birds)
- Rickettsial diseases such as Rocky Mountain spotted fever, rickettsialpox, recrudescent typhus, murine typhus, Q fever, and monocytic ehrlichiosis (small mammals, carnivores, deer)
- Salmonellosis (primarily rodents, reptiles, some birds)
- Tetanus (most animals)
- Tick-borne spirochetal diseases such as Lyme disease, and other relapsing fevers (rodents)
- Tuberculosis, avian (birds)
- Tuberculosis, mammalian (relatively uncommon in wild animals)
- Tularemia (burrowing rodents, ground squirrels, rabbits and hares)

Fungal Diseases

- Aspergillosis (birds, occasionally mammals)
- Histoplasmosis (colonial birds or mammals where excrement accumulates)
- Ringworm (mammals, occasionally birds)

Viral Diseases

- Hantavirus (rodents)
- Rabies (coyotes, foxes, raccoons, skunks, some bats)
- West Nile virus (birds)

Often, only someone with expertise in a particular species may recognize an animal's symptoms indicating a potential human health hazard. Eliminating the hazards can be complicated. Each one is resistant to different factors. For example, freezing specimens prior to preparation will not destroy some bacteria and viruses, such as some rickettsial diseases and rabies. Freeze-drying will preserve many pathogens for prolonged periods.

Taking material from the wild into collections also can involve hazardous materials used to tranquilize, kill, clean, or otherwise prepare specimens. These hazards vary with the type of specimen and preservation method (dry, wet, low temperature, microscopy).

Provide safe conditions; ensure that:

- human health and safety is paramount; superseding all other concerns
- all health and safety risks are taken seriously and eliminated to the degree possible
- unnecessary risks are avoided
- warnings about health and safety risks are provided verbally and in writing to staff and collection users
- compliance with governmental health and safety regulations is standard practice, including:
 - monitoring for hazards
 - using engineering controls to mitigate hazards
 - worker training, including training in the use of personal protective equipment where engineering controls are not feasible
- collection personnel work in pairs when safety is a concern (for example, handling heavy equipment or toxic chemicals)
- staff properly dispose of all parts discarded during the preservation process (such as internal organs of vertebrates preserved as dried skins)

For additional information related to curatorial health and safety, see Chapter 11. You can also obtain information concerning methods to mitigate biohazards without compromising the utility of specimens from:

- The Centers for Disease Control and Prevention (CDC)
(800) 311-3435
www.cdc.gov
- The American Society of Mammalogists
www.mammalsociety.org

SECTION II: PRESERVATION OF BIOLOGICAL COLLECTIONS IN GENERAL

A. Overview

For purposes of organization and discussion, preservation is subdivided into the following stages:

- **Stabilization:** preservation activities associated with halting active deterioration and minimizing the risk of loss, damage, or disorder as it relates to the specimen and its associated information
- **Processing:** preservation activities beyond stabilization that are related to making the specimen available for use
- **Storage:** preservation activities associated with housing of the

specimens for the sake of access, organization, and protection

- **Maintenance:** preservation activities associated with corrective actions in response to a real or perceived problem

By definition, both emergency management and pest management are “maintenance” activities.

Note: Most specimens you receive will already be stabilized. They probably will have undergone some degree of processing too. Park biologists or outside researchers working under contract usually carry out this work. These scientists are familiar with the standard protocols for specimen stabilization and processing in their fields. Curatorial staff should be involved only in some aspects of processing, and in the storage and maintenance of the collections.

Make sure you have documentation as to what processes were used by the researcher.

B. Stabilization of Biological Specimens

1. *What is stabilization?*

Stabilization includes:

- halting active deterioration of a specimen
- minimizing the risk of loss, damage, or disorder of the specimen and its associated information

2. *What issues should I consider prior to stabilization?*

Carefully evaluate all incoming material:

- Does the quality of the specimen(s) and associated information comply with standards for the collection?
- Does the acquisition of the specimen(s) comply with the park’s Scope of Collection Statement and:
 - serve institutional mission and goals?
 - contribute to the utility of the collection?
 - pose any health and safety risks?
 - pose any legal, ethical, or social problems?
 - require special resources for collection or salvage, preparation, or long-term care?

3. *What issues should I consider once we decide to initiate stabilization of specimens?*

- What is the condition of the specimen? Keep in mind that it may be:
 - alive
 - recently dead

- in some state of decomposition (as a result of necropsy, freezing, or delay between collection and initial stabilization)

- What parts of the specimen are to be preserved?
- What kind of stabilization (dry, wet, low temperature) is appropriate?
- Does stabilization require additional materials for support of the specimen and/or specialized equipment for the process?
- What professional standards (for example, positioning) apply to the stabilization technique?
- What special methods (for example, exposing diagnostic features) must be applied to insure maximum use of the specimen?
- Does completion of the stabilization of choice make the specimen available for use? Will subsequent processing treatments be required? For example, a vascular plant specimen may be stable after pressing to remove moisture. However, it won't be useful until it has been mounted.

4. *What information should I document during stabilization of biological specimens?*

Because so much information is lost when a specimen is removed from its natural setting and collected, the collector documents:

- ecological information
- field conditions
- observations about the specimen and its habitat
- accurate locality data

Such documentation usually includes:

- field notes
- field tags applied to the specimen
- photographs
- digital images
- original artwork
- sound or video recordings.

Remember: At a minimum, researchers working in NPS areas are required to provide the park with:

- an Investigator's Annual Report for each year of the permit
- copies of field notes, data, reports, publications and/or other materials resulting from the studies

Be sure that these data are included in the collection and are cross-

referenced with the specimen/s, including all catalog information in ANCS+.

Note information about the individual specimen. Often this involves recognizing the species and assigning a field or preparation number (especially in the case of tissues and/or parasites removed from the specimen). This allows the specimen to be cross-referenced to other related information. Some disciplines may not assign these numbers because all of the pertinent information is maintained with the dry specimen (this is sometimes the case in botany).

The collector also should have provided provenience information. This is especially important for ensuring specimen value and use within the collection. Such data include:

- the species
- the field or preparation number
- the methods used for stabilization from the time of collecting until received at the park
- where the specimen was collected
- when the specimen was
 - collected (including the method, as well as any drug and/or chemical used during the collection of animal specimens)
 - prepared
- who collected the specimen
- who stabilized the specimen

Hopefully, the collector also included:

- any special handling procedures
- information related to parasites or tissues collected from the specimen

You also need to be sure to document the natural conditions and features of the specimen, particularly those that may be changed by stabilization. Examples include color, markings, weight, dimensions, sex, reproductive condition, age, and physical condition.

Any documentation about specimen history, such as condition of the specimen, environmental conditions, and stabilization methods and materials, may prove useful in determining the integrity of the specimen for various uses.

5. *Are there any other issues related to stabilization that*

Yes. Be sure to bear in mind that:

I should consider?

- Various stabilization methods are used but can vary significantly between disciplines. Refer to the specific stabilization methods in subsequent sections for more information.
- The intended use of the specimen can significantly influence how it will be preserved.
- Stabilization should be the first step in preservation. Take care to ensure that stabilization practices comply with disciplinary standards.

6. *What protection concerns and practices are involved with stabilization of biological specimens?*

During stabilization, you should:

- ensure the relationship of the specimens and their data
- protect the specimens from all agents of deterioration

The agents of deterioration that most often damage specimens during stabilization depend greatly on the nature of stabilization. Refer to the specific stabilization methods in subsequent sections for more information.

7. *What health and safety concerns should I be aware of during stabilization?*

Specimens may contain animal-borne pathogens and/or toxic chemicals that are part of the plants or animals themselves. If chemicals are used as part of the stabilization process there may be additional risks. These hazards depend upon the specific chemicals. Protect yourself with good personal hygiene. Use appropriate engineering controls (such as biohazards hoods and chemical vapor hoods), and properly chosen gloves. If engineering controls are unavailable (as is often the case during field stabilization), you may need to use additional personal protective equipment.

C. Processing of Biological Specimens

1. *What is processing?*

Processing involves those activities beyond stabilization that are related to making the specimen available for use. These activities depend on standard practices established by individual disciplines. Processing typically includes a sequence of steps that includes:

- preparation
- accessioning
- cataloging
- labeling
- loans or other collection access

2. *What are the NPS requirements for processing of project-generated specimens?*

Specimens that you acquire should already have been accessioned, cataloged, and labeled. [This is required of researchers \(NPS and non-NPS\) who have NPS collection permits.](#)

Director's Order #24: NPS Museum Collections Management, requires [all](#) project budgets to include funding for the basic management of project-generated collections. Collections management includes:

- cataloging
- labeling
- conservation examination and treatment (including preparation)
- initial storage of objects and specimens
- organization and storage of project documentation (field data, reports, and other associated archival materials)

Do not accept project-generated collections that lack such basic documentation and means for protection. As noted above, DO #24 requires project budgets to include funding for basic collections management. It is not the responsibility of the park's museum program to fund cataloging and initial storage and organization of project-generated specimens and archives. You can contact your regional/SO curator or the Senior Curator of Natural History for advice.

All resource management projects that generate collections must provide funding for accessioning, cataloging, and labeling of specimens, as well as initial conservation and storage of both specimens and related archives. Budgets should include sufficient funding for NPS or contract cataloging or specimens and archives, storage materials, and equipment, such as cabinetry.

3. *What is involved in preparation of specimens?*

The initial step in processing is the preparation of the specimen (although it can be part of the stabilization process). If you lack critical data about the specimen (such as measurements), it is important to obtain the information at this time.

Anticipate specimen use, so that you can make correct decisions about:

- applying appropriate preparation techniques
- conforming to disciplinary standards
- positioning and exposing diagnostic features
- possibly exposing additional features commonly used for descriptive and comparative research

You also must ultimately decide w
only part(s) of it. This will lead to
supplemental support systems. To
appropriate subject matter experts ;

Processing can require special care. Be sure that you have all of the necessary processing obligations. If you have a backlog of unprocessed or partially processed specimens, they may have little or no utility.

4. *What is involved in accessioning biological specimens?*

For information concerning accessioning of museum collections, see *Museum Handbook*, Part II (*MH-II*), Chapter 2. Additional accession information relevant to biological acquisitions that you should document includes:

- What taxonomic groups of specimens are represented by the acquisition?
- What methods of preservation are represented by the acquisition?
- Where was the acquisition collected?
- When was the material collected?

You should also include the following materials in the accession folder:

- a copy of the research proposal
- a copy of the research/collecting permit(s)

It's also helpful for researchers if you also provide a cross-reference to these documents' physical locations in the park archives in the ANCS+ catalog record(s).

Do not assume responsibility for specimens that have not been appropriately stabilized and prepared (such as a backlog of unprepared specimens maintained in freezers).

5. *What is involved in cataloging biological specimens?*

For information concerning cataloging biological specimens, see *MH-II*, Chapter 3 and the *ANCS User Manual*, Chapter 2, Section V. You also should include the following:

- When was the specimen collected?
- When was the specimen stabilized and prepared?
- Who stabilized and prepared the specimen?

6. *How should I label specimens?*

Depending on the specimen and preservation method, you can label:

- the specimen itself (some invertebrates and bones)
- support materials for the specimen, such as:
 - labels attached to herbarium sheets
 - microscope slides
 - insect pins
- tags tied to these specimens

- birds
- mammal skins
- fluid-preserved specimens
- labels attached to the outside or placed inside of containers
 - bags
 - boxes
 - vials
 - jars

In many instances, the park acronym and a catalog number may be the only label data. Additional information can be valuable for facilitating collection use and organization. See *MH-II*, Appendix J, Section K, “Natural History Specimens” for information concerning labeling biological collections.

7. *What materials should I use to label specimens?*

Always use stable materials and in an appropriate manner. Most specimens that you acquire will already have been accessioned, cataloged, and labeled. This is required of researchers who have NPS collection permits. Sometimes park staff may undertake these activities for material they have collected.

Paper Labels

Paper products can vary in quality and appropriateness for the preservation of biological specimens. Paper labels that you use should:

- be white
- have a neutral to slightly alkaline pH (pH 6.0-8.0);
- have a lignin content of less than 0.3%
- be of long-fibered cotton stock, although alpha-cellulose, ground-wood papers are also acceptable

Alkaline-buffered papers, which have a pH of 8.5 or higher, are not acceptable unless they are labels applied to herbarium sheets or packets, insect pins, microscope slides, or the exterior of boxes or other containers where they are not in direct contact with the specimens.

You can obtain acceptable archival-quality paper from various vendors. These include firms listed in *Tools of the Trade* or from some full-line office supply stores (although you may have to place a special order).

Plastic Labels

Do not use plastic labels. Most of the plastic labels that have been used with specimens in the past have not been stable. The exception to this general rule is Tyvek[®], a stable non-woven polyester.

Metal Labels

Metal labels are sometimes part of a specimen in the form of leg bands or ear tags. Always retain these with the specimen. **Do not use metal for other labels or label attachments**, as:

- most metals will oxidize and corrode when in contact with the specimens
- sharp edges and corners of the metal can cause physical damage to the specimen

Note: If a metal leg band or ear tag attached to a specimen is actively corroding, you may need to remove it from the specimen. Be sure to consult with a conservator and/or your regional/SO curator for guidance.

Inks

Inks must be resistant to light, fluids, and abrasion. Only use carbon-based, permanent, black ink to label specimens. Carbon inks do not fade. Commercial, black printing inks are usually carbon-based. Most laser printer and photocopier toner is also carbon-based. Laser and photocopiers apply toner with a certain amount of heat. This helps fuse the toner particles to the paper. Some inkjet printers now use pigment-based inks. Keep in mind though that only black, carbon-based pigments are acceptable for labeling biological specimens.

Liquid inks vary in quality. Black inks suitable for labeling should be drafting inks designed for writing on drafting film, using technical pens. These inks tend to be carbon-based with a neutral pH. They adhere well to almost any surface.

You also can use some fiber-tipped pens for labeling specimens. Once again, be sure to choose pens with carbon-based, black, liquid ink.

To test an ink, see how:

- long it takes for the ink to dry so that it will not smear
- well the dry ink resists abrasion
- well it resists water, alcohol, or other fluids that may be used in specimen preservation

For information concerning acceptable permanent inks, refer to *Tools of the Trade*.

Label Attachments

Attach tags to specimens with cotton thread of a thickness appropriate to the size of the specimen. The attachment should be:

- long enough to permit the tag to be read on both sides without stress on the specimen
- short enough that it does not become entangled with the specimen or

adjacent specimens

Do not use plastic or metal ties when labeling specimens. These can deteriorate from contact with the specimens. They also can cause mechanical and/or chemical damage to the specimens.

Herbarium Sheet Labels

Attach labels to herbarium sheets and specimen packets in botany collections using methylcellulose paste. Other types of adhesives may break down over time and cause:

- labels to separate from sheets
- deposits of deterioration products on labels and sheets

Methylcellulose paste is compatible with the sheets, packets, and labels. To make this adhesive, follow these steps:

1. Choose a very pure, high-viscosity methylcellulose powder (such as Methocel A4M, a grade A, 4,000 viscosity methylcellulose made by Dow Chemical).
2. Mix the methylcellulose powder with distilled or deionized water.
3. Form a thick gel (following the manufacturer's directions).
4. Dilute the mixture with ethanol or an ethanol and water solution.
5. This creates a quick drying adhesive for paper materials.

Methylcellulose may not work well to attach paper labels to all surfaces. To adhere a label to a glass vial you may need to use an acrylic adhesive. Self-adhesive, foil-backed, paper labels with an acrylic adhesive are available from various conservation suppliers.

Labeling Directly On Specimens

You can directly label bone, shell, and other fairly smooth-surfaced specimens. Use a stable acrylic resin (such as Acryloid® B-72) to seal the surface below the number. If you don't seal the surface, the ink can penetrate and disperse through cracks. This can cause permanent alteration or requiring aggressive scraping to remove labeling errors. See *Conserve O Gram (COG)* 1/4 for additional information.

8. *How should I handle biological specimens during processing?*

To protect specimens during processing:

- provide dedicated, open workspace
- use stable work surfaces
- provide ultraviolet-filtered lighting with good color rendering capacity (a Color Rendering Index of 90 or higher)
- maintain clean surfaces
- remove clutter

- wear nitrile gloves
- maintain sufficient space for each specimen
- handle only one specimen at a time
- use trays or carts to move specimens to and from work areas
- keep food, fluids, and other contaminants away from work and storage areas
- avoid working with specimens in areas where environmental conditions are outside an acceptable range
- don't handle or move specimens more than necessary (use a padded turntable for examination to reduce handling)
- request assistance if needed to safely handle or transport a specimen

9. *What should I know about preparation materials?*

Most specimens have been fully stabilized and prepared prior to receipt. The materials used in these processes can affect the preservation and utility of the specimens. It is impossible at this time to state the best preparation techniques with certainty. Therefore, it's always important to carefully document all methods and materials to help determine appropriate use of the specimens over time and to aid future conservation efforts.

10. *How should I document a specimen's condition during processing?*

Prepare condition reports to document a specimen's condition. Collections care routinely involves condition reporting. It's impossible for you to prepare a condition report for each specimen. Therefore, you'll need to prioritize specimen condition reporting. At a minimum, prepare condition reports for:

- type specimens
- endangered or rare species
- unique and historically important specimens
- specimens that are removed from the collection to be sent on loan, or to be used for interpretation or exhibition
- specimens that need treatment

ANCS+ contains a condition report module that you can use to document the condition of specimens in your collection. See the *ANCS User Manual*, Chapter 3, Section IV: Condition Reports Supplemental Record, for additional information.

Your collection may require a more detailed condition examination. You also may require additional information concerning appropriate care for certain specimens. Discuss these needs with your regional/SO curator. He or she can assist you to hire a natural history conservator to conduct a Collection Condition Survey (CCS) of your collection. For additional information concerning a CCS, see Chapter 3, Section D.

11. *Are there any special*

If the specimens were not fully prepared when received at the park, the health and safety issues may be similar to those for stabilization. If the

health and safety concerns during processing?

specimens have been fully prepared, the risks will be primarily physical or chemical. If you know about all stabilization and preparation materials, it's possible for you to mitigate or eliminate chemical threats through the use of engineering controls and personal protective equipment (PPE). You can reduce the physical risks by paying careful attention to proper handling and storage techniques.

12. *What do I need to know about loans of specimens?*

For information concerning incoming loans, see *MH-II*, Chapter 2, Section P. For information concerning outgoing loans, see *MH-II*, Chapter 5. The following additional standards pertain to loans of biological specimens:

Type Specimens

- are never loaned in some disciplines (e.g., mammalogy)
- are routinely loaned in some disciplines (e.g., invertebrate zoology and botany)
- are usually subject to more stringent loan conditions than non-type material

Important Notes Concerning Transport of Type Specimens:

- The best method of transport to ensure a type specimen's security is hand delivery.
- Specimens shipped by air or mail may be subjected to various types of electronic, chemical, or radiological examination and treatment. Such procedures may damage the specimen; either physically and/or render it useless for certain types of research.
- Some commercial carriers do not accept animals, either alive or dead, for transport. Consult with your carrier in advance concerning their policies.
- If you must send a type specimen by post or commercial carrier, be sure that you can track the package.

Other Important Points Concerning Loans

- rare species or unique specimens are almost never loaned
- entire holdings of a series of specimens are not sent in a single loan
- normal loan duration is six months with provisions for extensions upon request
- shipping containers for outgoing loans are used to return the loans
- loans are not shipped during the end-of-year holiday season due to the risk of delays or losses due to the increased volume of holiday mail
- loan shipments (and indeed, any shipment of specimens for any reason) must fully comply with all applicable State and Federal regulations regarding:
 - shipping documentation

- the shipment of endangered species
- transporting hazardous materials

Be sure that the borrowing institution uses the NPS annotation label (Form 10-510) to note any annotations. The NPS annotation label is available in ANCS+. It's a good idea to send several blank NPS annotation labels with the loan paperwork for the borrower to use, if needed. Upon the loan's return to the park, be sure to note label annotations on the specimen's catalog record in ANCS+.

13. *What techniques should I use when packing and shipping specimens for loans?*

For information concerning proper packing and shipping techniques, see Chapter 6, "Handling, Packing, and Shipping Museum Objects." To ensure proper handling of specimens, you also should:

- use a rigid container (ideally a watertight container) for shipping to protect from external physical forces and environmental risks
- include appropriate invoices, permit information, and other shipping documentation to avoid unnecessary opening of the container
- provide instructions on how to properly open and remove the contents of the shipment
- provide appropriate support and cushioning in the container to protect the specimens from mechanical damage
- provide reasonably stable materials in contact with specimens
- wrap each specimen individually for protection and to contain specimen parts in the event of damage
- be sure address information is correct and legible, and that copies of the shipper and recipient addresses are inside the package
- follow all applicable laws and regulations regarding the packaging of any hazardous materials for any shipping method

There is no guarantee that the same care will be provided when the loan is returned, but hopefully your demonstration of proper methods and materials will serve as a positive example for loan recipients.

14. *What are the regulations pertaining to shipments of hazardous specimens?*

If you ship any hazardous materials (HAZMAT), including some specimens (such as radioactive, toxic, flammable, or otherwise dangerous specimens) via a **commercial carrier** (Federal Express, UPS, or similar firms) you must comply with all State and Federal regulations, especially Title 49, Code of Federal Regulations (49CFR).

YOU CANNOT SHIP HAZARDOUS MATERIALS USING THE U.S. POSTAL SERVICE. IT'S ILLEGAL.

In the United States, the U.S. Department of Transportation (DOT) administers the Federal regulations pertaining to transportation of HAZMAT, known internationally as dangerous goods. 49CFR, Parts 100 through 185, govern the transportation of hazardous materials in the U.S. As noted above, all commercial shipments of hazardous material must be in accordance with the Hazardous Materials Regulations (HMR) found in

Parts 171 through 180 of Title 49, CFR.

According to 49CFR, you **CANNOT** offer a HAZMAT shipment to a commercial carrier for transportation unless it has been packaged, labeled, and prepared for shipment in accordance with the Hazardous Materials Regulations (HMR) (see Parts 171 through 180 of 49CFR). The regulations also require that:

- All packages and containers that you use for shipping by commercial carrier must meet the requirements of the HMR
- Individuals who package, label, and/or prepare shipping papers for hazardous shipments must take a HAZMAT shipping training course. The training must include general awareness and familiarization, function-specific, and safety training.

If your park needs to transport a specimen that is considered HAZMAT, you have three options:

- **Use a U.S. Government vehicle** driven by a properly trained park employee who is knowledgeable of any risks posed by the specimen(s). Such shipments are not regulated by the requirements of the HMR noted above.
- **Hire a Commercial Carrier and a hazardous materials packaging contractor.** The contractor (who has been trained and certified in all DOT HAZMAT regulations) will prepare your package for shipment according to the HMR. The contractor will then forward your shipment to the commercial carrier. Companies that offer these services are usually located near large international airports or port facilities.
- **Complete a HAZMAT shipping training course that meets DOT requirements.** Several firms and organizations offer such courses, which are classroom-based, distance-learning/Internet, or via a CD-ROM or other method. The DOT has a CD-ROM based training program. Once you have completed the training you can legally pack such shipments for commercial transport.

For additional information concerning transportation of hazardous specimens and training requirements, consult the DOT:

U.S. Department of Transportation
Research and Special Programs Administration
Office of Hazardous Materials Safety
400 7th Street, SW
Washington, DC 20590
(800) 467-4922; (202) 366-8553
<http://hazmat.dot.gov>

D. Storage of Biological Collections

1. *How should I store biological collections?*

To ensure proper storage, consider:

- location

- security
- organization
- housings
 - storage designs
 - storage systems
 - storage materials

2. *Where should I locate storage?*

Locate biological collection storage in an area:

- where there are minimal natural or human-caused hazards
- where you can control access
- where you can organize the collection in a logical manner
- that staff can easily monitor and control the environment

Off-site facilities, basements, attics, and irregular or fragmented spaces do not serve the interests of good collection management, care, or use. Storage should meet the standards of the NPS Checklist for Preservation and protection of Museum Collections (“Museum Checklist”). For additional information concerning the Museum Checklist, see Appendix F: NPS Museum Collections Management Checklists.

3. *How can I ensure the security of biological collections in storage?*

Provide appropriate security for the specimens through:

- control of access and use
 - policies
 - procedures and other standard operations
 - key control
 - restrictions
- physical security
 - door and cabinet locks
 - staff supervision of all collection access
 - electronic detection and surveillance systems (alarm systems, coded keycards, closed circuit television surveillance, etc.)

For further information concerning the security of collections, see:

- Chapter 9, “Museum Collections Security and Fire Protection.”
- ASIS Standing Committee on Museum, Library and Archive Security. *Suggested Guidelines in Museum Security*. Alexandria: ASIS International, 1997. Available at on the web at:

<www.stevекeller.com/steve/pdf_files/SecurityStandards/GuidelinesRev97.pdf>.

4. *How should I organize my park's biological collection?*

- Layne, Stevan P. *The Cultural Property Protection Manual*. Denver: Layne Consultants International, 2002.

You can organize your collection:

- following disciplinary standards that comply with the most recently accepted classification system for the taxonomic group in question
- based on a progression from primitive to complex forms, often reflecting a described classification system
 - begin subdivisions within the broadest pertinent taxonomic division (phyla or class)
 - continue the phylogenetic arrangement at least to the family or subfamily level

Below these levels it is common to use an alphabetic arrangement:

- genera are organized alphabetically within a given family
- species are organized alphabetically within a given genus
- such organization may continue to sub-specific levels as well

Organization beyond the classification system may vary among disciplines and/or parks:

- Parks with large collections of specimens of the same genus or species (or subspecies, if applicable) may want to arrange specimens alphabetically by geographical designations for the collecting locality (such as state, park district, or county).
- Beyond classification and geographical arrangement, arrange specimens numerically by catalog number.

If you organize your park's biological collection this way, every specimen has a designated and predictable location. You can then easily retrieve and replace specimens and conduct periodic inventories without difficulty.

5. *What about other methods of arrangement?*

Sometimes you may need to adapt your arrangement patterns to provide effective use of space for:

- over-sized specimens
- specimens with multiple parts that are not best accommodated in the same storage unit (dry study skins with parts preserved in fluids)
- collections from more than one park

Remember: Be sure that your method of arrangement:

- provides appropriate protection for the specimens

- enables the specimens to be accessed with ease for research use

For additional assistance deciding on a suitable arrangement system, consult:

- Your regional and network-level contacts:
 - regional /SO curator
 - regional chief scientist
 - network inventory and monitoring coordinator
- NPS Senior Curator of Natural History
- Park scientists/natural resource management staff
- Major research users of your park's natural science collection

6. *Are there any other issues related to collection arrangement that I should consider?*

After you organize your biological collection based on an acceptable classification system, and arrange it in a simple and logical pattern, be sure that you can easily locate specimens. You can facilitate this by:

- signage
 - label each aisle of storage units to indicate the beginning and ending groups housed within the aisle
 - label each cabinet, drawer, and shelf to indicate the beginning and ending groups in the unit
- floor plans that detail where the various specimen groups are located

The ultimate goal is to allow ease of access to a specimen with minimal handling of other specimens.

7. *What issues should I consider when planning a new or upgraded storage facility for biological specimens?*

Discuss your storage needs with your regional/SO curator, park and regional/SO natural resource management staff, network inventory and monitoring coordinator, park maintenance staff, park partners such as local universities, other agencies, and museums, and other subject matter experts. Refer to Chapter 7, "Museum Collections Storage" for NPS standards and requirements for collections storage. Also refer to:

- Rose, C., C. Hawks, and H. Genoways (eds.). *Storage of Natural History Collections: A Preventive Conservation Approach*. Washington, D.C.: Society for the Preservation of Natural History Collections, 1995.
- Rose, C. L., and A. R. de Torres (eds.). *Storage of Natural History Collections: Ideas and Practical Solutions*. Washington, D.C.: Society for the Preservation of Natural History Collections, 1992.

For ordering information concerning either volume, visit the Society for the Preservation of Natural History Collections' (SPNHC) website at: <<http://www.spnhc.org/>>.

Things to consider for biological collections storage facilities include:

- Have a dedicated storage area. Do not co-locate offices, collections processing, supply storage, or any other functions within collections

storage areas.

- Provide 350 lbs. per square foot floor-loading capacity for storage areas that will house compact or mobile storage systems.
 - This will also permit you to safely move cabinets, collections on pallets, or objects in crates using lift equipment such as power lift stackers and pallet trucks.
 - Make sure that access corridors between freight elevators, storerooms, and exhibit areas have similar floor loading capacities.
- Ensure that the entrance to any storage area is large enough in both dimensions to accommodate full-unit cabinets and large objects.
- Avoid dropped ceilings in all storage areas, and, to the extent possible, elsewhere in the building. Dropped ceilings:
 - provide a habitat for pests
 - disguise the source of leaks
 - contain materials that can generate dust and debris that foul particulate filtration systems
- Avoid raised decks or other raised flooring for compact storage systems. These provide a habitat for pests. Install compactor tracks into properly leveled and coated concrete floors (see below).
- Install a sanitary perimeter around any building that houses collections. This is a 3' wide pea gravel border, 4" deep, along the outside of the exterior walls.
 - The trench should slope away from the building and be lined with a polyethylene membrane to inhibit plant growth.
 - Use non-flowering plants for landscaping outside the sanitary perimeter. Flowering plants attract dermestid beetles.
 - Avoid attaching mercury vapor or tungsten lighting to buildings as these attract insects.
- Equip all storerooms with fire detection and water-based, automatic fire suppression systems.
 - Program for, and ensure regular testing, inspection, and maintenance of the systems.
 - For assistance, contact your regional structural fire management officer (SFMO) and regional/SO curator.
- Label all pipes and ductwork so that staff can adequately protect collections that may have to be stored below them. Do not locate any pipes (other than sprinkler lines and minimal ductwork) inside storage areas.
- Install seals around all duct and pipe chases where they pass through walls, floors, or ceilings. You can block these passages with "Stuf-it"

copper wool gauze to keep insect pests and rodents out of storage areas. “Stuf-it” copper wool gauze is available from:

Allen Special Products, Inc.
1610 Bethlehem Pike #B3
Hatfield, PA 19440
(800) 848-6805

- Avoid interior duct linings. Where needed for noise control or to reduce condensation, use external duct linings.
- Install climate control equipment outside the storage room. This eliminates the need to access the room to maintain the equipment. This will also help protect the collections from equipment leaks.
- Filter all incoming and recirculated air to the American Society of Heating, Refrigerating and Air-Conditioning Engineers (ASHRAE) 90-95% level.
- Plan for a moderately dry environment.
 - The relative humidity (RH) range that is most suited to the majority of natural history collections is 40-60%. This assumes that the building fabric is designed for this range.
 - Specimens and objects inside well-sealed cabinets can withstand external environments from 30-65% RH over the course of a year. In a temperate climate, the collections inside the cabinets will enjoy a very stable RH somewhere between 45% and 55%.
 - Most natural history materials will preserve very well at a RH of 40-50%.
 - Some materials are very sensitive to mechanical damage at a RH below 40%, (teeth, bone, and shell). Fluctuations in RH below 40% can cause these materials to crack and spall, even without the impetus of mechanical damage.
- The optimum temperature for storage of biological collections depends upon the type of preservation (dry, wet, low temperature). Consult the appropriate sections of the text for information.
- Avoid all natural light, and use indirect lighting or filtered fluorescent lighting to reduce the potential for damage to collections from ultraviolet radiation.
- Paint walls and ceilings white or a very light color. White reflects much of the visible-light spectrum. You can then reduce the intensity of the light from various light sources in work or storage areas.
 - White or light walls and ceilings permit easy monitoring for dust, and cobwebs and other indications that insects may be present.
 - Most white paints contain titanium dioxide, which absorbs part of the ultraviolet radiation from fluorescent lighting, reducing the UV

in any reflected light.

- Avoid oil-based paints, single-component epoxies, alkyd paints, or oil-modified polyurethane coatings.
- Select an acrylic emulsion latex (interior or exterior), vinyl acrylic, or acrylic urethane coating for walls and ceilings.
- Coat concrete floors (after appropriate curing) with a solvent-borne epoxy sealer, topped with a moisture-cure epoxy sealer.
 - Avoid all other floor coverings. Anything else will require wet cleaning or will be a source of particulate or gaseous pollutants.
 - When worn, you can replace the topcoat without having to evacuate the collections from the area.
 - Use a clear or pigmented epoxy. Do not use white, it will always appear scuffed.

8. *What storage systems will best protect my park's biological collections?*

The agents of deterioration that pose the greatest risks in storage of collections vary according to the level of containment for the specimens. Collections in open storage are far more vulnerable than those stored in closed storage, as shown in Tables T.3 and T.4., below:

Threat	Floor	Racks/Screens	Shelving
Neglect	Poor	Poor	Poor-Fair

Direct Physical Forces	Poor	Fair	Poor-Fair
Criminal Activity	Poor	Poor-Good	Poor
Fire	Poor	Poor	Poor
Water	Poor	Fair	Fair
Pests	Poor	Poor	Poor
Contaminants (especially dust and outdoor air pollutants)	Poor	Poor	Poor
Visible and UV Light	Poor	Poor-Fair	Fair
Inappropriate Temperature	Poor	Poor	Poor
Inappropriate/Fluctuating Relative Humidity	Poor	Poor	Poor

Table T.3. Quality of protection against agents of deterioration for collections in open storage. Based on work by Barbara Moore and Stephen Williams .

Threat	Poorly Sealed Cabinet	Well Sealed Cabinet (elevated or on compactor storage)	Compactor Shelves
Neglect	Poor	Fair-Good	Poor-Fair
Direct Physical Forces	Good	Good	Fair-Good
Criminal Activity	Good	Good	Good
Fire	Fair	Fair-Good	Fair
Water	Fair	Good	Fair
Pests	Fair	Good	Fair
Contaminants (especially dust and outdoor air pollutants)	Poor-Fair	Good	Fair-Good
Visible and UV Light	Good	Good	Fair-Good
Inappropriate Temperature	Poor-Fair	Good	Fair
Inappropriate/Fluctuating Relative Humidity	Poor-Fair	Good	Poor

Table T.4. Quality of protection against agents of deterioration on collections in closed storage. Based on work by Barbara Moore and Stephen Williams.

For most collections, locked, well-sealed, properly installed and leveled cabinets reduce the risk of most agents of deterioration. Good cabinets:

- exclude pests (most pest infestations are then the result of negligence)
- greatly deter theft
- can eliminate damage from:
 - water leaks
 - light
 - most particulate pollutants
 - soot and other debris during a fire
 - some forms of physical damage
 - the impact of humidity extremes and fluctuations

Cabinets can maintain a reasonably stable relative humidity level (even

when you open doors periodically for access). If you keep doors closed, the cabinets will provide acceptable environments through short-term failure of building systems.

Remember: Cabinets do not provide protection against neglect. Lack of appropriate organization, cushioning, and support will still expose specimens to mechanical damage from physical forces. Well-sealed cabinets also will contain any vapor off-gassed by poor quality storage materials. This will increase the potential for chemical damage to collections stored with these materials.

9. *What types of storage equipment should I use for biological collections?*

The storage equipment of choice may depend on the type of biological collection (dry, wet, low temperature, etc.). Refer to subsequent sections for more information.

One of the best ways to provide proper long-term care for your collections at minimal cost is to use appropriate storage equipment. Good quality cabinets and other storage equipment will last for several decades if properly maintained. Purchase and use standardized storage equipment. This permits:

- bulk purchases, which can result in substantial cost savings
- drawers and other interior fittings to be traded among cabinets to suit specific needs

When purchasing new storage equipment, include the following specifications:

- steel construction (some lightweight aluminum or molded high-density polyethylene shelving may be useful in certain instances)
- high gloss, epoxy powder coatings
- exterior surfaces that are flush (no indentations or recesses other than at door latches)
- no interior spaces of any kind that cannot be reached with a vacuum cleaner - this includes hollow doors unless they are completely sealed
- hinged, lift-off doors, or doors that open completely and fold back flat against adjacent cabinets to facilitate
 - cleaning of the cabinet interiors
 - rearrangement of drawers and shelves
 - installation and removal of specimens
- door locks, generally keyed alike to prevent a proliferation of keys or a tendency to avoid locking the doors
- d-style tubular neoprene or silicone door gaskets

- these “rubberized” materials will off-gas minor amounts of sulfur (herbarium materials are sensitive to sulfur gases)
- you can use either neoprene or silicone foam gaskets for sulfur-sensitive collections, but the d-style gaskets provide a better seal against pests and pollutants and for most biological collections are probably worth the comparatively minor risk from the sulfur
- alcohol-cure silicone sealants (no acetic acid should be present in any sealants used in cabinets)
- powder-coated steel interior fittings
- light-tight construction for all cabinets (where light can enter, so can insect pests and dust)
- leveling feet
- 4” or higher legs

Note: The GSA contractors that manufacture NPS standard museum storage cabinets also sell cabinet platforms that you can use to elevate the cabinets 6” above the floor. See *Tools of the Trade* for more information.

- casters, or dollies with locking casters for deep shelving units, these
 - allow the units to be easily moved, even when fully loaded
 - help maximize the use of space in a storage area (they are an inexpensive compact storage design)
- removable restraining bars to keep items from toppling from shelving units during an earthquake
- suspension (roller-bearing) or Permaslide® or equivalent systems for pull-out drawers. Avoid friction systems as these rapidly abrade and can deposit fine particulates from the paint on collection objects.

When you acquire new storage cabinets, purchase only white or off-white equipment and containers. This facilitates housekeeping, pest monitoring, and "crumb" monitoring. "Crumb" monitoring refers to examining stored collections for signs of decrepitation (small particles dislodged from specimens as a result of biological, chemical, or physical deterioration). It's virtually impossible to inspect for pests against anything other than a white or very light background.

For additional information concerning proper storage equipment for biological collections, see *MH-I*, Chapter 7, “Museum Collections Storage” and *Tools of the Trade*. Refer to *Tools of the Trade* for equipment product descriptions and illustrations, vendor contact information, and current Federal government contracts.

10. *What special concerns should I consider when installing new storage equipment?*

Use the following steps when installing new storage equipment. This will help ensure that the equipment will protect the collections and be durable over time. You should use similar steps if you must move storage equipment after the initial installation.

- If possible, arrange for the manufacturer to install the equipment.
- If park staff are moving or installing cabinets:
 - Use mechanized equipment such as a stacker.
 - Move cabinets with a nearly complete complement of shelves or drawers (but without the collections). This helps reduce distortion of the cabinet during the move.
 - Remember that a good quality, steel museum storage cabinet with drawers can weigh as much as 600 lbs.
 - If you move cabinets improperly, this will reduce their capacity to provide protection for collections.
- Test all incoming storage cabinets for off-gassing.
 - This includes any powder-coated cabinets.
 - Coatings may off-gas.
 - Cabinets may contain many other materials besides the coating.
 - Air out all storage cabinets (with doors open) for as long as possible before installation of any collection objects.

Note: Information on test methods is given below.

- Level all cabinets (front-to-back and side-to-side) whenever they are newly installed or moved. Cabinets that are not level will not close properly and:
 - provide limited microclimate control
 - allow dust and insect pests to enter
- After leveling, test all incoming storage cabinets to insure that they are light tight:
 - Place a battery-powered lantern or 9-volt flashlights inside a leveled cabinet, then close and lock the door.
 - Turn off all room lights.
 - Carefully examine the cabinet for several minutes for signs of light from within.
 - If light can be seen, mark the area with a post-it note and examine it under normal lighting.
 - If the light leak is a result of a flaw in the cabinet from anything

other than a minor problem around the door gasket, contact the manufacturer for repairs or replacement.

- You can fill minor leaks around the door gasket. Use 3M[®] self-adhesive neoprene foam gasket material (or equivalent), which is available in various widths at hardware stores.
- Refer all major problems with door gaskets to the cabinet's manufacturer.

11. *What types of storage materials are appropriate for use with biological collections?*

The storage materials of choice may depend on the type of biological collection (dry, wet, low temperature, etc.). Refer to subsequent sections for more information about storage materials. In general, storage materials that are appropriate for use with biological collections include:

- closed-cell polyethylene foam (Volara[®] Type A or Plastazote[®])
- opaque non-woven (spun-bond) polyethylene fabric (Tyvek[®])
- polyester film
- high density molded polypropylene or polyethylene
- pH-neutral, alpha-cellulose, lignin-free, unbuffered papers & boards
- pH-neutral, unbuffered, 100% cotton paper products
- pure cotton fabrics (thoroughly washed)
- polyester fiber (non-bonded, high loft, resin-free polyester fiberfill)
- medium or high density, phenol-formaldehyde-impregnated, exterior grade plywood that is surface laminated with melamine, or with vapor barrier foil/plastic laminates. **Note:** See the Safety Note concerning the use of aluminum foil laminates with certain treated specimens, in #13, below)
- glassware

Contact with alkaline-buffered (“buffered”) paper can damage pigments and proteins in bird and mammal specimens. It can also interfere with herbarium chemical taxonomy studies. Always use unbuffered, acid-free materials with natural history specimens, or line buffered trays with unbuffered blotting paper to eliminate direct contact with alkalis.

For additional information concerning proper storage materials for biological collections, see *MH-I*, Chapter 7, “Museum Collections Storage” and *Tools of the Trade*.

12. *Are there any cautions to using the above materials with biological specimens?*

Polyethylene melts at about 250°F. This temperature is far below that at which many bird and mammal study skins, untanned skins, feathered or haired specimens, plant specimens, and paper are damaged by heat alone. If the foam is in direct contact, it will melt and damage the specimens **before** they would ordinarily be damaged by the heat of a fire. Separate from

direct contact with specimens by using pH-neutral, 100% cotton rag blotting paper or pH- neutral, smooth-surfaced tissue.

Polyethylene foams and films develop a static charge in low humidity conditions and can damage:

- friable surfaces, such as the periostracum on many shells
- fragile parts such as those on some plant specimens
- hair or feathers

Other cautions concerning polyethylene foam include:

- Polyethylene foam will readily adhere to some small specimens and objects, such as those with fur or with sharp protrusions (a specimen or object can be easily be torn in lifting it from the foam surface).
- Some expanded polyethylene foams have open pores along cut edges that are an appropriate size for some insects to deposit eggs or for insect larvae to pupate. Using appropriate ventilation, seal edges with a hot air gun, or cut the foam with a hot knife to seal the openings.

Considerations for other materials include:

- Polyester film (Mylar D[®], Melinex 516[®]) has a very high melting point, but develops a static charge at humidity levels of about 40% or less.
- Polypropylene may have the same problems as those noted above for polyethylene foams.
- Polyester fiber should always be separated from direct contact with any collection item that has small protrusions or a friable surface.

13. *What materials should not be used for storage of biological specimens?*

Don't use any of the following materials , they can damage specimens:

- polystyrene
- polyvinyl chloride (PVC) plastics
- polyurethane foams and oil-based polyurethane varnishes
- synthetic polymers containing unstable plasticizers or other additives
- alkyd enamel paints
- bakelite (a hard, black plastic), which decomposes when exposed to alcohol and/or formaldehyde vapor
- acidic paper products
- alkaline-buffered paper products (in collections containing proteins, animal pigments, or intended for use in some biochemical or chemical taxonomy studies)
- wood and most wood products, although you can use wood to construct

pallets for large specimens if:

- you use a well ventilated room
- you properly seal the wood
- the collection materials are not in direct contact with the wood
- most uncoated metals (see safety note below)
- most commercial grade textiles
- cotton batting (is extremely hygroscopic and will attract and hold moisture on specimens)
- natural rubber

IMPORTANT SAFETY NOTE: Aluminum metal, and vapor barrier materials made with aluminum foil can be a hazard if used with collections that have been treated for pest control using mercury salts or chlorinated compounds. These chemicals react with aluminum.

E. Maintenance of Biological Collections

1. *What is maintenance?*

Maintenance includes all of the corrective actions in response to a real or perceived problem. It can include a variety of issues, but the most common maintenance concerns include:

- updating information
- housekeeping in storage and exhibit areas
- emergency preparedness, response, and salvage
- specimen cleaning
- specimen treatment
- pest management

2. *What information management issues are related to maintenance of biological collections?*

Maintenance includes the following information management issues:

- the need to update information (to reflect ongoing changes in the classification system as researchers develop a better understanding of taxonomic relationships) to:
 - specimens
 - drawer labels
 - catalog records

- databases

Be sure to document information related to any associated collections of tissue or parasites. You also should obtain reports of further analysis of these collections.

- detailed documentation and analyses of environmental conditions in collection areas
- condition reporting
- recording images of specimens
- deaccessioning specimens (see *MH-II*, Chapter 6, “Deaccessioning”)

Maintenance activities may depend on the type of biological collection (dry, wet, low temperature, etc.) in question. Refer to subsequent sections for more information about specific maintenance issues.

Include all pertinent information in ANCS+, especially loan, exhibit, and treatment histories. Also, note all publications in which a specimen has been cited. If this information is available, the value of individual specimens and the collection as a whole is enhanced.

3. *How important is housekeeping for biological collections?*

As with all other collections, good housekeeping provides for the long-term preservation of biological specimens. Proper housekeeping minimizes particulate pollutants and eliminates habitats and materials attractive to insect and rodent pests.

4. *What housekeeping strategies should I use for long-term preservation of biological specimens?*

For NPS housekeeping and storage requirements, see the “NPS Checklist for Preservation and Protection of Museum Collections” in Appendix F: NPS Museum Collections Management Checklists, as well as Chapter 7: Museum Collection Storage and Chapter 13: Museum Housekeeping.

Other steps that you should take include:

- Place polypropylene fiber mats outside the doors to the storage rooms to reduce dust and dirt entering the collection area.
- Use High Efficiency Particulate Air (HEPA)-filtered vacuums as your primary cleaning tool. Unlike conventional vacuums, HEPA vacuums do not redistribute fine particulates into the area being cleaned. See *Tools of the Trade* for product information.
- Avoid wet cleaning in collection areas. If necessary, use spot cleaning to remove stains.
 - There is no need for regular wet cleaning in storage areas.
 - Large areas of damp carpet or floors can raise humidity levels.
- Do not use spray cleaners or aerosol cleaners in collection areas.
 - Do not use these in any space that shares a ventilation system with

collection areas.

- Spray on cleaning rags outside collection areas, only.
- Do not use chlorinated cleaners anywhere in collection areas. For safer cleaning alternatives, see *COG 2/21* “Safer Cleaning Alternatives for the Museum and Visitor Center.”
- Use specialized cleaners (such as Brillianize[®]) for many plastics, such as exhibit cases. Never spray directly onto the case surfaces, or on rags while in collection areas.

5. *What should I know about emergency management, response and recovery?*

Emergency planning and management is vital. Be sure that you are prepared to deal with all emergencies and potential disasters. Have an up-to-date Emergency Operations Plan (EOP), conduct drills, and ensure that all staff are aware of their responsibilities in event of an emergency. This will reduce damage to, or loss of, life or property.

For additional information, refer to *MH-I*, Chapter 10, and your park’s EOP. For questions about your park’s EOP, consult your chief ranger, safety officer, and regional/SO curator.

6. *What do I need to know about salvaging biological specimens following an emergency?*

Salvaging specimens after an emergency or a disaster is usually geared towards stabilization. It normally occurs within the first 48-hours after the collection and/or area is secured. Initial stabilization may involve some treatments. However, these treatments are not designed for restoration or repair, but to eliminate further damage.

There are a number of salvage techniques for many kinds of specimens. A very useful reference is:

Ball, C. and A. Yardley-Jones. *Help! A Survivor’s Guide to Emergency Preparedness*. Museum Excellence Series: Book 3. Edmonton: Museums Alberta, 2003. Ordering information at: <www.museumsalberta.ab.ca>.

There are conservators who have extensive experience in salvage of biological materials. Be sure to include their names and contact information in your park’s EOP response call list. Information about appropriate conservators is available on the web at <<http://www.aic-faic.org/guide/form.html>>.

Following an emergency, many specimens and/or collections may require treatment. These treatments can be extremely complex. Refer such work to a professional conservator.

7. *What about cleaning biological specimens?*

Cleaning of specimens poses a variety of problems:

- Removing particulate matter on most specimens can risk mechanical damage.
- Vacuuming some specimens, such as study skins, will remove ectoparasites that may be useful in verifying the identity of the host organism.
 - Before you vacuum or otherwise clean any research specimens, be sure that the “pest” is indeed a “recent” infestation rather than an

ectoparasite.

To ensure that specimens are not damaged during cleaning, follow these general guidelines:

- Carefully vacuum specimens using a HEPA-filtered vacuum and small tools.
 - Do not dust wipe specimens or use forced air.
 - For some hard-surfaced specimens, you can use a soft brush to brush surface dust into the nozzle of a HEPA-filtered vacuum.
- Restrict your cleaning to specimens that are otherwise in good condition.
- Do not attempt to vacuum specimens with:
 - flaking skin, scales, periostraca, or paint
 - loose feathers or hair
 - fragile parts or appendages
- Avoid cleaning botanical specimens, herbarium sheets, and insects.
- Consult a conservator for advice before cleaning any group of specimens for the first time.

Consult with a conservator before attempting any cleaning that may require water or organic solvents. This applies to all types of specimens and whatever sort of material is to be removed from them.

8. *Are there any other concerns regarding treatments of biological specimens?*

When specimens have suffered mechanical, biological, or chemical damage, you should stabilize the material by non-interventive means rather than to try to repair the damage:

- If there are detached parts, contain them so that they will not be lost. Don't attempt to reattach them.
- You can stabilize a cracked or broken specimen with an appropriate support.

Specimens with historic or interpretive value can be treated, but only by a conservator. Even in these instances, all repair materials must be easily distinguished from original specimen materials.

NOTE: Avoid any action that might compromise the integrity of research specimens.

9. *Are there any health and*

Many of the health and safety concerns can be mitigated by the use of proper personal protective equipment (PPE). This includes gloves and the

safety concerns related to maintenance of biological collections?

use of other appropriate equipment, such as HEPA-filtered vacuums.

Activities beyond routine maintenance may require you to:

- have full knowledge of potential material interactions
- use properly ventilated laboratory facilities
- use respirators and additional PPE

The use of some personal protective equipment (PPE), such as respirators, requires a medical evaluation, formal training, and fit testing. For additional information concerning respirator use, see COG 2/13.

10. *Should I document cleaning, treatment, and salvage activities?*

Yes. All cleaning is essentially an irreversible treatment. Always document all cleaning activities (whether done by collection staff or a conservator). Provide written documentation and photographs or other images as well. You also should document any treatment (however simple it may appear to be) in writing, and in photographs or images taken before, during, and after the treatment.

During emergency salvage operations, it's acceptable for you to eliminate individual specimen reports. However, you'll need to document all steps in the overall immediate salvage (in writing and in some imaging system). Record specific damage to particularly valuable specimens and specimens on loan from other museums. Note the specific salvage methods used. Such information may be important for insurance purposes as well as for the future preservation and utility of the specimens.

11. *How can I protect biological specimens from pests?*

In the past, pest management incorporated repeated application of pesticides. This often involved multiple types over time. There are numerous problems with this approach, including:

- laws and regulations
- health and safety
- environmental quality
- questionable effectiveness
- materials interactions

Practice the principles of Integrated Pest Management (IPM). IPM is the best approach to dealing with pests in museum collections. It is a holistic, environmentally-friendly, and sustainable means of pest control. IPM does not exclude the use of pesticides. It does however, offer many alternatives for achieving the same goal. Because dry collections are at greater risk from pests than other types of collections, refer to Section III for more information about IPM and pest management.

The National Park Service implemented an IPM program in the early 1980s. Since then, the NPS has reduced pesticide use by over 60 percent, while also improving the effectiveness of Servicewide pest management efforts.

SECTION III: DRY BIOLOGICAL COLLECTIONS

A. Overview

1. *What are dry biological collections?*

Dry collections consist of those specimens that are preserved in a dry state.

2. *Why are some biological specimens preserved in a dry state?*

Two factors influence decisions about preserving specimens this way:

- **Rigidity.** Some specimens can be preserved naturally (starfish) or artificially (vascular plants) with sufficient rigidity to accommodate normal handling. Such specimens often are suitable for dry preservation.
- **Specific characteristics.** Drying may provide the best available means to preserve natural colors (for example, butterflies) or distinguishing features (such as skeletal parts or surface details). Such specimens in a dry state may have great potential for interpretation and research.

3. *What types of biological specimens are usually included in dry collections?*

Plants

- Non-vascular (selected forms of lower plants such as lichens and many fungi)
- Vascular (flowering and coniferous plants)

Animals

- Invertebrates (selected forms such as many insects, corals and some crustacea, mollusks and echinoderms)
- Vertebrates
 - fish (skeletal parts, mounted specimens)
 - reptiles (skeletal parts, scutes or shells, large skins, mounted specimens)
 - birds (skeletal parts, skins, mounted specimens)
 - mammals (skeletal parts, skins, antlers, horns, mounted specimens)

Ancillary Collections

In addition to the specimens, ancillary or support collections are commonly preserved in a dry state. Examples include nests, eggs, replicas, scats, wood samples, labels, and specimen or collection records.

Note: Some biological collections may include photographs used to represent the voucher specimen, especially for some threatened and endangered species. An example of this is a photograph attached to a labeled herbarium sheet.

4. *What are the primary agents of deterioration that affect dry collections?*

Under certain conditions, dry collections can be damaged by all of the agents of deterioration. They are particularly susceptible to neglect, pests, contaminants, visible and UV light, inappropriate levels of temperature and humidity, and improper handling.

5. *How does neglect affect dry collections?*

Neglect can cause collections to become:

- damaged
- lost
- disordered (a lack of organization that impedes collection access)

Major causes of neglect include:

- insufficient knowledge and skills
- failure to provide adequate documentation
- apathy
- lack of administrative support
- an imbalance of resources

6. *How do pests threaten dry collections?*

Dry biological collections contain organic material that is attractive to many insect pests. Fresh material that is not thoroughly dry is highly at risk. However, even dry material is attractive to some pests. The species of insect pest varies according to the type of collection. Some insect pests prefer dried plant materials, while others feed on animal materials .

Vertebrate pests (such as mice) can damage any material either through nesting or feeding. They can also cause soiling with body fluids or excrement.

7. *How can contaminants adversely affect dry collections?*

Contaminants may occur in particulate or gaseous forms. Specimens can be contaminated due to:

- particulates such as dust and soot from atmospheric pollutants
- emergencies
- poor storage and exhibit designs

Particulates can:

- be abrasive
- soil surfaces
- obscure fine details
- attract and hold gas -phase pollutants on the surface of specimens, promoting chemical damage
- necessitate repeated cleaning of collections that:
 - is a drain on a museum's resources
 - causes wear and tear on the collections

- has the potential for severe damage during the cleaning process.

Specimens may acquire other particulate contaminants such as:

- asbestos from deterioration of building materials
- polychlorinated biphenyls (PCBs), lead, and cadmium as a result of the deterioration of paints used in buildings or on storage furniture
- other chemicals used for preparation treatments or pest control

Not all of these cause chemical or physical deterioration of the specimens, but they may have an impact on use of the specimens for interpretation or research.

Other points to remember include:

- Gaseous pollutants are generally inorganic or organic vapors that form acids when they react with moisture in the air.
- Inorganic acid gases, primarily sulfur and nitrogen oxides, are present in very high concentrations near urban centers. They may be high in some rural areas as well. In a museum, they contribute to deterioration of many materials. However, they will have the greatest effect on cellulosic materials stored or exhibited outside of cabinets.
- Organic acid vapors cause deterioration to most dry specimens and their documentation at varying rates, according to:
 - the type and concentration of pollutant
 - the nature of the materials in the collection

Organic acids can:

- cause chemical disintegration of organic materials
- attack calcareous materials (materials containing calcium such as shell, eggshell, and coral)
- damage to calcareous materials can range from unsightly surface alteration to complete conversion to a powder

The major sources of organic acid pollutants are:

- wood and wood products (including wood pulp paper and cardboard)
- additives in some plastics and fabrics
- certain adhesives and coatings, especially alkyd enamel paints, *including the baked enamel paints used on some storage furniture*

8. *How does visible and ultraviolet light affect dry collections?*

Most dry specimen materials are either very sensitive or moderately sensitive to visible light. Visible light causes fading of biological pigments. Fortunately, “structural colors” in animals are not greatly affected by visual light. These include multiple iridescent colors and some blues and greens

that are found in feathers. Others include colors in the exoskeletons and wings of many insects.

As with visible light, most dry specimen materials are also either very sensitive or moderately sensitive to ultraviolet radiation. Ultraviolet radiation causes:

- alteration of biological pigments (fading or shifts in color).
- damage to chemical bonds in plant and animal materials
 - UV breaks down the structure of the materials to leave them weakened or embrittled
 - this loss of structural integrity can alter the appearance of structural colors

9. *How does temperature and relative humidity affect dry collections?*

High temperatures contribute to:

- desiccation
- denaturation of proteins
- lipid and resin migration

In general, the rate of any chemical reaction that damages specimens will double with each 10°C/50° F rise in temperature.

Temperatures below freezing:

- cause expansion of free water, which can result in cell rupture in fresh plant and animal specimens
- permit lipid migration (via ruptured cells) in fresh animal specimens
- will not stop the growth of microorganisms unless the temperatures are below -20°C/-4°F
- will not stop enzymatic activity
- increase the rate at which lipids oxidize, which can cause damage to pigments and proteins
- may cause migration of salts in tanned skins. This can lead to collapse of capillaries in the skin

Temperature fluctuations can result in expansion and contraction of some materials, such as teeth. This can cause cracking.

Excessive moisture in the air (above about 65% relative humidity) encourages:

- mold

- pest infestations
- chemical reactions that can be damaging to organic material
- deformation of material such as tanned or untanned skins and wood samples (deformation is also caused by fluctuating relative humidity)
- softening of some adhesives

Relative humidity below 40% may contribute to embrittlement of rigid materials such as:

- teeth
- ivory
- bone
- mollusk shell
- the outer covering on some mollusk shells (the periostracum)
- wood samples

Embrittlement will leave these specimens very susceptible to mechanical damage.

Fluctuations in relative humidity can cause cracking or splitting of these materials. This is especially true at humidity levels below 40%.

Maintain relative humidity levels below 40% to promote the preservation of freeze-dried specimens that are prone to deteriorate rapidly at higher levels of RH.

10. *Are there any special rules for handling dry collections?*

Yes. You can easily damage dry collections by improper handling, inadequate support, carelessness, and poor storage techniques. In addition to the recommendations in Chapter 6 and those previously noted in this appendix, use the following handling guidelines to prevent damage to your dry collections:

- Ensure that everyone who uses the collection knows how to properly handle herbarium specimens. Develop written guidelines for use.
- Use large storage trays to move specimens housed in envelopes and small specimen trays.
- Used a padded cart to move material from room to room.
- Avoid handling specimens with your bare hands. Wear *unpowdered* nitrile gloves. As with other collection items, gloves will protect the specimen from oils in the hands, but they'll also protect you from specimens that may cause you to have an allergic reaction.

- Use a light colored work area, so that any material that breaks off can easily be seen and retrieved.
- If you require extra light, use it sparingly.
- Use forceps or gloved hands to carefully move loose material.

Herbarium Specimens

- Do not overcrowd specimens:
 - Don't place too many specimens on one cabinet shelf.
 - Leave enough space on each shelf to allow for easy expansion of the collection in the future.
- When you access a specimen, always remove the entire genus folder.
 - Never attempt to remove just one herbarium sheet from a stack of folders. This can damage the specimens.
 - Support the bottom of the genus folder with both hands when moving it.
- Move herbarium sheets by providing complete support from the bottom.
- Don't shuffle sheets as if they were cards or pages of a book.
- Do not turn sheets upside-down.
 - Stack sheets neatly to the side if specimens on the bottom of the stack are needed.
 - Be sure that the edges of sheets never hit or scrape specimens below.
- Whenever you remove a folder from storage, place a marker in the location to ensure that the folder is returned to its proper place.
- Do not bend sheets to force them under a microscope. Use a hand lens or long-armed microscope.
- Have fragment folders close at hand for attachment to herbarium sheets if needed. If a portion comes loose, place it in a fragment folder attached to the specimen's sheet immediately.
- Equip the research area with work surfaces that are large enough to accommodate a number of herbarium sheets, as well as additional space to ensure that the individual sheets will not strike each other, which may damage a specimen.

The most common cause of damage to herbarium specimens is through improper handling of herbarium sheets.

Insect Specimens

- Have empty pinning boxes close by in case they are needed for temporary placement of specimens.
- Do not leave drawers or specimens out of storage cabinets overnight, as they are more likely to be infested when outside cabinets.
- Remove boxes or the entire cabinet drawer; do not remove just single specimens from a cabinet for use.
- Leave specimens in the pinning box when viewing under the microscope.
- Use extreme care when removing an individual specimen from a storage box for such purposes as examining the ventral side of the specimen. Do not hit other specimens in the box.
- If there is not enough room on the pin above the specimen to safely grab it with your fingers use pinning forceps:
 - Use pinning forceps with the smaller size pins that flex easily.
 - Carefully pull the pin straight up from the pinning bottom of the box with an easy, smooth motion.
- Avoid unnecessary shaking of the specimen on the pin; do not jerk or quickly pull at the pin. Rough handling can cause sections of the specimen to fall off.
- If the underside of the pinned specimen must be viewed:
 - Pin the specimen into a large eraser or a piece of cork for easier handling.
 - Other possible pinning surfaces include a pinning box with all but one side removed, or an “L-cork” (two pieces of cork joined in an L-shape). Hold the “L” on either the backside or bottom, as needed to view the specimen.

Bird and Mammal Collections

Important Note: Be very careful if you don't know a specimen's complete treatment history. In such cases, assume that it's been treated with pesticides. For additional information concerning contaminated collections, see Question 12, below.

- Wear a white lab coat or lab apron. Animal hair, feather fragments, and insect frass are most likely to be seen against a white background.
- Handle/examine specimens on clean, cushioned, white or light-colored work surfaces. You can use a covering of 1/8” polyethylene foam to cushion a table or desktop effectively.

- Don't remove taxidermy mounts from their original supports.
 - The specimen armatures are under tension.
 - If you remove the rods extending from the feet from their original support, the armatures can move and damage the specimen.
- Handle freeze-dried specimens as little as possible and with great care. Freeze-dried specimens are extremely fragile.

11. *What security issues are related to dry collections?*

Theft is an increasing concern. This is because these collections are often subject to less stringent security measures than many cultural collections. Specimens at risk of theft include:

- ivory
- rhinoceros horn
- horn sheaths and antlers
- some claws and talons
- tanned skins
- skulls
- mollusk and egg shells
- insects
- seeds
- hallucinogenic plants
- specimens of rare, endangered, and extinct animals and plants

Supplementary archival materials, such as original scientific artwork, photographs, and field journals kept by well-known scientists are also vulnerable to theft.

12. *Are there any health and safety concerns associated with dry collections?*

Toxic materials may be present in various forms. This is usually a result of previous treatments. This includes chemicals that may have been used in specimen preparation or processing, such as:

- tanning with chromium salts
- use of asbestos in some taxidermy preparations
- residues from pesticide treatments such as arsenic, DDT, and mercury salts

Other potential hazards include:

- residues from inadvertent contamination of specimens by asbestos from deteriorating building materials

- lead paint dust from old cabinets
- mold spores from past exposure to liquid water or prolonged high relative humidity

Some park staff and collection users may have allergic reactions to hair, feathers, dander, insect debris, and certain specimens (such as poison ivy). Specimens with thorns, spines, or quills, claws, talons, antlers, horns, and long beaks, can cause physical injury during handling. At the same time, handling biological material during stabilization and preparation can pose the risk of numerous biohazards, varying with the specimen.

For additional information concerning handling of contaminated collections, refer to the following *Conserve O Grams*:

- 2/2 “Ethylene Oxide Health and Safety Update”
- 2/3 “Arsenic Health and Safety Update”
- 2/4 “Diclorvos (Vapona) Update”
- 2/10 “Hazardous Materials in Your Collection”
- 2/11 “Health and Safety Risks of Asbestos”
- 2/14 “DDT Health and Safety Update”
- 2/16 “Chronology of Pesticides Used on National Park Service Collections”
- 2/17 “Physical Properties and Health Effects of Pesticides Used on National Park Service Collections”
- 2/19 “Guidelines for the Handling of Pesticide Contaminated Collections”

B. Special Concerns for the Stabilization of Dry Specimens

1. *How are dry specimens stabilized?*

Dry stabilization is used for many biological collections. However, the activities can vary significantly between disciplines. For example:

- some non-vascular plant specimens (such as lichens) and some types of invertebrate specimens involve simple desiccation, such that the specimen does not need further physical alteration before it is ready for use
- for some non-vascular plants and most vascular plants, researchers use plant presses for positioning, compressing, and drying (with or without heat) individual specimens
- some invertebrates are treated with chemicals to either control bacterial decomposition of soft body parts by removing fats or oils, to degrade

soft body parts to facilitate removal or to relax the specimen

- insects are typically pinned and carefully positioned before being dried
 - some insects (for example, butterflies) are occasionally dried without positioning
 - these specimens are rehydrated and positioned as part of the processing stage or because they will be used for analysis of nucleic acids (rehydration will damage or destroy DNA)
- skins of various vertebrates, particularly oversized specimens, are flattened and dried (or tanned)
- whole skins and wings, or detached wings of some birds are shaped and dried
- skins of smaller birds and mammals are positioned and dried after being stuffed with a fibrous material (for example, cotton or polyester fiber) and supported with rigid materials (for example, wire, wood, or paper board)
- the flesh is normally removed from skeletal parts of vertebrate specimens to facilitate drying

Stabilization should be the first step in preservation. Take care to ensure that stabilization practices comply with disciplinary standards.

2. *What protection concerns and practices are involved with stabilization of dry specimens?*

During stabilization, you should:

- ensure the relationship of the specimens and their data
- protect the specimens from pests
- maintain the specimens in a dry condition

The agents of deterioration that most often damage specimens during stabilization are neglect, pests, and high relative humidity. (See Table T.5 below.)

PRIORITY 1	PRIORITY 2	PRIORITY 3
Neglect	Visible light and UV radiation	Criminal Activity
Pests	Contaminants	Fire
Inappropriate RH	Physical Forces	Inappropriate T
	Water	

Table T.5. Agents of deterioration during stabilization of specimens for dry collections.

Well-trained staff and proper procedures reduce the risk of neglect during stabilization. Appropriate use of screened or other enclosures, and careful procedures will reduce the potential for pest infestations. Proper ventilation during drying will reduce the potential for mold and rot that are fostered in fresh specimens by their moisture content and high relative humidity.

C. Special Concerns for the Processing of Dry Biological Specimens

1. *Are there any general observations about processing of dry specimens?*

- Dried, compressed non-vascular plants and most vascular plants are strapped or glued to herbarium sheets along with appropriate labels.
- Dried skins of various vertebrates, particularly oversized specimens, are often tanned as part of the processing treatment.
- Skeletal parts of vertebrate specimens receive processing treatments, such as mechanical cleaning, cleaning by insects or other invertebrates, and chemical baths, to remove non-osseous tissues and some fats.
- Final preparation of many dry specimens may involve placing the specimen or its parts in a container, such as a box, packet, tray, or vial.

Remember: Processing requires special expertise, time, and facilities. Be sure that you have all of the necessary resources before accepting processing obligations. If you don't, your collection will have a backlog of unprocessed or partially processed specimens. Such collections are of little or no utility.

2. *What are the agents of deterioration that affect dry collections during processing?*

The primary agents of deterioration for dry specimens during processing are neglect, physical forces, and pests (see Table T.6 below). Insufficient knowledge and skills can result in poor processing techniques, rendering a specimen useless. Dry organic material without protection is at risk to pest damage. Many processing treatments result in damage by physical forces as specimens are labeled, reshaped, or shipped for loans.

PRIORITY 1	PRIORITY 2	PRIORITY 3
Neglect	Contaminants	Criminal activity
Physical Forces	Water	Fire

Pests	Inappropriate RH	Inappropriate T
	Visible light and UV radiation	

Table T.6. Impact of agents of deterioration on specimens during processing.

D. Special Maintenance Concerns for Dry Collections

1. *What should I do about migrating lipids that are staining the specimen or surrounding materials?*

This can be a complicated cleaning problem. It may indicate that the specimen was not properly processed initially; not all lipids were removed. As lipids migrate from specimens and deteriorate, they can stain the surface of the specimen. They also can:

- stain other surfaces
- collect dust
- dissolve some inks
- develop unpleasant odors
- attract pests

As a result, it's sometimes in the best interests of the specimen (and collection workers) for you to remove migrating lipids.

Traditionally, lipids were removed by “degreasing” treatments that involve various solvents. Many of these solvents pose serious threats to human health and safety. Some degreasing treatments involve hot water or steam, which may damage specimens. Labile lipids (the unsaturated fats and oils that migrate out of specimens) are polyhydric alcohols. Most can be removed with ethanol.

Always refer to a natural history conservator before cleaning a specimen with water or other solvents. This applies to all specimens and all types of material to be removed from the specimen.

Important Note: (After first consulting a natural history curator), be extremely careful when removing lipids. You do not want the solvent to cause deterioration of other organic material, such as collagen. This can lead to the deterioration of a specimen.

2. *How should I protect dry specimens from pests?*

Practice the principles of Integrated Pest Management (IPM). IPM is the best approach to dealing with pests in museum collections. It is a holistic, environmentally-friendly, and sustainable means of pest control. IPM does not exclude the use of pesticides. It does however, offer many alternatives for achieving the same goal. IPM includes both **passive and active measures**.

NPS *Management Policies* (2001) requires that “The Service, and each park unit, will use an IPM approach to address pest issues. Proposed pest management activities must be conducted according to the IPM process prescribed in Director’s Order #77-7: Integrated Pest Management.”

For additional information, policies, and procedures, see *MH-I*, Chapter 5, “Biological Infestations,” Director’s Order #77-7, *Integrated Pest Management* (forthcoming) and the *Integrated Pest Management Manual*. You can also consult with your park’s IPM coordinator and your regional/SO curator.

3. *What passive IPM measures should I take to protect the collection?*

Passive measures are proactive ongoing daily activities that can significantly reduce the risks of pest infestations. Examples include:

- appropriate housekeeping procedures
- ensuring that food, drink, smoking, and live plants are never allowed in *or near* collections areas
 - Never locate break rooms or other areas where food is stored, prepared, and/or consumed near collections areas.
 - Be sure that garbage and other debris (including recycling materials) for disposal are never stored nor allowed to accumulate near collections areas.
- good work habits, such as replacing specimens in cabinets or other containers after use
- proper storage (using closed storage units)
- basic preventive practices, such as the quarantine of incoming specimens
- not storing curatorial supplies in collections storage areas
 - packing materials can contain pests; store these and all other supplies away from collections areas
- eliminating or reducing one or more of the four requirements for pest survival
 - nourishment
 - water
 - shelter
 - proper climatic conditions
- surveillance
 - periodic inspections, especially of materials particularly prone to pests (freeze-dried specimens) and natural traps (windows and spider webs)

- use of sticky traps (with or without pheromones)
- documentation
 - inspection dates
 - cleaning activities (what and when)
- proper design of facilities
- proper storage equipment

Remember: Passive measures do NOT include ongoing or scheduled application of toxic chemicals on specimens.

4. *What active IPM measures should I take to protect the collection?*

Active IPM measures are your responses to the discovery of possible pest problems, such as:

- pest damage
- pest excrement
- pest remains
- live pests

Always keep good collection records. They can help you determine if the evidence of pests represents a new problem or a pre-existing problem that has been addressed in the past.

When you discover a pest problem, the active measures that you can take range from surveillance to eradication procedures.

The first steps that you should take are to:

- Identify the problem:
 - What evidence is there?
 - What species of pest is it?
 - What life stages of pests are involved?
 - Are there active pests present or is it possible that the evidence is from an old infestation that is no longer active?
- Isolate the problem
 - Bag potentially infested specimens in polyethylene sheeting. Monitor them for evidence of pest activity to verify that there is an active infestation.

- Determine the magnitude of the problem. Find out how much of the collection is infested.
- If possible, move affected material away from the rest of the collection.
- Thoroughly inspect and clean the infested areas and materials.
- Replace storage supplies that may have been associated with the infestation.

Maintain close surveillance of the infested area and materials. A good option is to use pest “sticky” traps.

5. *What should I do if eradication is necessary?*

If active measures require eradication procedures, you have several options before you should use hazardous chemical pesticides:

- various kinds of traps
- freezing temperatures
- temperatures of 60°C/140°F
- low-oxygen or anoxic (without oxygen) environments

See *COG 3/8* “Controlling Insect Pests: Alternatives to Pesticides.”

6. *What kind of traps can I use?*

Various kinds of traps can help eradicate pests, but their success will depend on the pest species and circumstances.

- **Sticky traps** involve a variety of forms (boxes, fly-paper, boards) having surfaces with a sticky adhesive to trap pests. Place sticky traps in high-risk areas throughout the facility and inside specimen cases.
 - Check the traps frequently. Use an established schedule
 - Identify and record any pests that you discover.
 - Replace traps as necessary.

See *COG 3/7* “Monitoring Insect Pests with Sticky Traps.”

- **Pheromone traps** may involve sticky traps, but with the addition of species-specific pheromones.
 - Pheromones are natural scents insect species use to communicate with each other.
 - Pheromone traps tend to be sex-specific in effectiveness.
 - Certain pests can be strongly attracted to the traps from the surrounding area. This provides an extremely effective early warning system of pest presence.
 - Pheromone traps are only available for certain insects such as

cigarette beetles (*Lasioderma*), drug store beetles (*Stegobium*), Indian meal moths (*Plodia*), and warehouse beetles (*Trogoderma*).

- Other types are being developed and may be available soon.
- **Snap traps** (mouse traps) can be used for rats and mice, although they are sometimes messy.
- **Glue boards** are similar to sticky traps but larger.
 - They are often used against rats and mice.
 - Although glue boards are cleaner to use than snap traps, they will not kill the animal. Use snap traps to ensure the pest's quick and painless end.
- **Small electronic devices** that emit high frequency sound waves are sometimes used as a deterrent, in place of traps.
 - They are usually targeted against mice, rats, and other rodents.
 - The effectiveness of such devices is questioned. According to Health Canada's Pest Management Regulatory Agency, "Rodents may adapt to the devices over time and return to areas within the device's range" (Health Canada, 2001).

7. *Are there any cautions related to traps that I should consider?*

Yes. Be sure to bear in mind the following:

- Don't allow traps to become a food source for other problem pests.
 - Conduct regular monitoring of all pest traps.
 - Dispose of traps when they are no longer useful (if they contain a large quantity of trapped pests or lose their "stickiness").
- Avoid the use of pheromone traps or baited traps inside collection storage areas or cabinets if there is a risk of attracting pests into the collection area from an outside location.

8. *How can I use freezing temperatures to eliminate a pest problem?*

You can use freezing temperatures to kill pests in specimens or storage materials. Be sure to properly encapsulate the materials and follow these procedures:

- Encapsulate the items in two layers of well-sealed polyethylene bags or sheeting.
- Freeze the specimen as rapidly as possible. Slow cooling allows some insects to produce a "natural antifreeze."
- Freeze the materials for at least fourteen days at -20°C/-4°F.
 - Shorter periods may be effective with some species or if colder temperatures are used.
 - For temperatures above -20°C/-4°F, much longer periods are required for complete insect pest eradication.

- Do not use shorter periods interrupted by thawing. This will produce freeze-hardy insects. Insect eggs will not be completely eradicated during the shorter freezing periods.

Be sure that the specimens and other materials have thawed completely before you remove the polyethylene wrapping. This will prevent condensation of moisture on the specimens. During thawing, moisture should condense on the polyethylene.

For additional information concerning freezing for pest control, see:

- *COG 3/6* “An Insect Pest Control Procedure: The Freezing Process.”
- *CCI Notes 3/3* “Controlling Insect Pests with Low Temperature.” By Tom Strang. Canadian Conservation Institute, Ottawa (1997). Available for \$2.00 USD (+shipping) from the CCI website at: <<http://www.cci-icc.gc.ca>>.

9. *How can I use heat to eliminate a pest problem?*

All life stages of insects can be eradicated by subjecting the affected materials to a temperature of 60°C/140°F. Use this method for infested storage materials that have high melting points, and for stacks of dry herbarium specimens. **Do not use this process for animal specimens.**

For an inexpensive and rapid heat treatment:

- 1) Encapsulate the items to be treated in 6mil black plastic.
- 2) Then place the encapsulated materials in a clear plastic “greenhouse” and use solar energy to create the heat.

This system was developed by Tom Strang of the Canadian Conservation Institute (CCI), and is fully described in:

WAAC Newsletter, 23:2 “Solar Bagging: Putting Sunlight to Work to Eliminate Insect Infestations in Mere Hours.” By B. Baskin. Western Association for Art Conservation (2001). Ordering information available at: <<http://palimpsest.stanford.edu/waac>>.

10. *How can I use a low-oxygen environment to treat a pest problem?*

Another method to eradicate pests in dry specimens and storage materials is to create a low-oxygen or no-oxygen (anoxic) environment. You can create a low-oxygen or anoxic environment by using carbon dioxide or nitrogen gas in a commercially available chamber. Or you can use an oxygen scavenger in special made-to-order enclosures. These methods require specialized training or assistance for effective use. See *COG 3/9* “Anoxic Microenvironments: A Treatment for Pest Control.”

11. *If necessary, can I still use chemical treatments to eliminate a pest problem?*

If all of the non-chemical methods listed above fail to eradicate the pests affecting your collection, you may need to utilize certain chemical treatments. Discuss the matter with your park’s IPM coordinator, safety officer, and regional/SO IPM coordinator if necessary. There may be a least-toxic alternative that will work.

Do not attempt to apply any chemical insecticides yourself. NPS policy and local and state laws require that only individuals with formal training and certification can apply most chemical pesticides.

Only use chemical insecticides on non-collection materials. Such applications include around baseboards in a storage room or possibly to disinfest curatorial supplies.

12. *Where can I find additional information concerning IPM and pest control?*

For additional information, see the NPS *Integrated Pest Management Manual*, available on the web at <http://www1.nature.nps.gov/biology/ipm/manual/ipmmanual.htm>. The manual includes a module on museum pests.

Your park's IPM coordinator, safety officer, and natural resource management staff can assist you to develop an appropriate program to protect your collection. You also may wish to consult your regional/SO IPM coordinator, local university entomology faculty, county extension agent, local university natural history museum staff, or other specialists.

SECTION IV: WET BIOLOGICAL COLLECTIONS

A. Overview

- What are wet collections?*

Wet collections are specimens kept in a liquid preservative to prevent their deterioration.

The best available resource on the nature and care of wet biological collections is:

Simmon, J. 2002. Herpetological Collecting and Collections Management. Rev. ed. Herpetological Circulars No. 31. Society for the Study of Amphibians and Reptiles. For ordering information, visit the “Bibliomania! Herpetological Literature” website at: <<http://herplit.com/SSAR/circulars/HC31/simmons.html>>.
- Why are these specimens preserved in a wet form?*

Certain biological specimens are preserved in a wet form due to:

 - convenience
 - an intent to preserve body form and soft parts for a variety of uses

When color preservation is not critical and dry preservation sacrifices qualities needed for other intended uses, fluid preservation is beneficial.

Note: The size and flexibility of the specimen (or its parts) must allow effective chemical fixation, chemical preservation, and possible storage inside rigid containers (for example, glass jars, or metal or plastic tanks).
- What is fixation?*

Fixation is a stabilization process in which the fixative chemically bonds to the specimen to impede deterioration by enzymatic digestion or autolysis. Formalin, a solution of 40% formaldehyde gas in water that is then further diluted, is a common fixative. Usually the final solution contains about 4% formaldehyde in water and is referred to as 10% formalin.
- Are all wet specimens treated with a fixative?*

No. Some specimens are not treated with a fixative, but instead are placed immediately in an alcohol. Alcohols replace water in the tissues to reduce the potential for deterioration. Alcohols are considered to be denaturants, rather than fixatives.
- What types of preservative fluids are used for wet collections?*

Preservative fluids are those in which the specimen is housed for long-term storage, usually during the processing stage of specimen preparation. Alcohols, primarily 70-90% ethanol and 50-60% isopropanol, are common storage fluids for specimens that have been fixed or denatured.
- What types of specimens are usually included in wet collections?*

The following biological specimens are commonly subjected to wet preservation:

 - Plants
 - non-vascular (some forms)
 - vascular (particularly fleshy parts such as fruit or succulent vegetative parts)
 - Animals

- invertebrates (most forms)
- vertebrates (especially fish, reptiles, amphibians, soft eggs, larvae, many small specimens of birds and mammals, and viscera of birds and mammals)

7. *What are the primary agents of deterioration for wet collections?*

Most agents of deterioration might cause damage to wet collections under certain conditions, **but the primary causes of deterioration are usually related to fluid and container quality**. Other agents of deterioration that can affect wet collections include:

- Neglect (primarily the failure to monitor and maintain fluid levels and concentrations in containers)
- Visible and UV light
 - most natural pigments are very sensitive to the effects of visible light and ultraviolet radiation
 - visible and UV light will trigger photochemically induced reactions that may increase the rate of deterioration in the fluids around specimens
 - light, particularly UV, will also contribute to the deterioration of glass and plastic containers
- Inappropriate temperature (especially temperature fluctuations)
- Inappropriate relative humidity and fluctuations
- Fire (a special concern for collections stored in alcohols)
 - alcohol vapor from poorly sealed containers creates an explosion hazard
 - alcohols may serve as fuel for a fire
- Physical forces
 - earthquakes or other natural emergencies
 - explosions
 - dropping a glass container housing a wet specimen

Note: Fluids provide excellent cushioning against most vibration and minor shock, as long as the containers are not tightly packed with specimens.

8. *How can inappropriate temperature and temperature fluctuations adversely affect wet collections?*

- Contaminants resulting from improper mixing of fluids
- High temperatures will accelerate the drying of specimens removed from fluid.
- Low temperatures (below about 12.7°C/55°F):

- Will cause polymerization of unfixated formaldehyde. This results in milky strands that cannot maintain the equilibrium reaction that is the basis of fixation.
- Prolonged exposure to low temperatures may cause loss of fixation in formalin-fixed specimens.
- Low temperatures can improve the preservation of material that is denatured and stored in alcohol and has never been fixed in formalin.

9. *Can relative humidity adversely affect wet collections?*

Relative humidity has little importance for specimens in fluid. However:

- Excessively low relative humidity will accelerate drying of specimens removed from fluid.
- Excessively high relative humidity will contribute to corrosion of metal and glass containers.

10. *How can wet collections become contaminated?*

- **Fixatives** may have been improperly mixed using:

- tap water, which is often very alkaline
- saltwater, which can impede fixation

This results in poorly fixed specimens that may contain contaminants from water treatments or seawater components.

- **Alcohols**, the main storage fluids, can be contaminated if the initial quality of the alcohol is poor.
 - Low-grade ethanol may be contaminated by acetone.
 - Any chemical used in the collection should be laboratory grade, or higher.
 - Any ethanol that is used in a collection should be *undenatured*.
 - Denatured ethanol (ethanol that is not potable) will incorporate any of a number of deliberate contaminants, including, aviation fuel, acetone, fluorescent dyes, methanol, and purgatives. Such contaminants make the alcohol unsuitable for human consumption.
- **Containers** with decomposing seals or corroding metal lids have the potential to contaminate fluid preservatives.
 - They can discolor specimens as the decomposition/corrosion products leach into the fluid.
 - Also, any time fluid types are changed (for example, changing between isopropanol and ethanol) one fluid becomes the

contaminant of the other.

- **Labels** may react with fluid environments, depending on the materials involved.
 - The dissolution of label inks and colorants are common examples.
 - Metal labels and wires used to attach labels often corrode in fluids.
 - Corroding metals will deposit corrosion products on the specimens and can serve as catalysts for other reactions in the fluids.

Fortunately, the fluid environment is dynamic. It provides an optimum medium for chemical reactions and transfer of products; lipids, pigments, proteins, and other specimen components will leach into the fluids.

- If there are no outside energy sources, such as light, to drive the process, these reactions will eventually reach equilibrium.
- This results in both specimens and their fluid achieving a reasonably stable state, unless someone changes the fluids.

11. *Are there any special health and safety concerns related to wet collections?*

Many types of toxic chemicals are used for stabilization treatments and fluid storage media. To reduce your risk, have well-designed preparation, storage, and research facilities. Also, always use appropriate procedures.

Proper ventilation is extremely important. So is personal protective equipment (PPE). Use goggles designed to protect against spills and vapor, and aprons and gloves appropriate for each chemical.

Most chemicals used in fluid-preserved collections pose risks through inhalation or skin absorption. Some, like **alcohols and picric acid, also pose fire and explosion hazards**. The most common chemical hazards are:

- ethanol - flammable
- isopropanol - flammable
- formalin solutions - formaldehyde is considered to be a carcinogen
- fixatives containing metal salts (arsenic, chromium, copper, mercury)
- acids (acetic, boric, carbolic, glacial acetic, nitric, osmic, picric, pyroligneous, sulfuric, sulfurous, trichloroacetic)
- other chemicals that may be toxic (camphor, chloral hydrate, various glycols, phenoxetol, methanol, thymol)
- dyes and stains (used in clearing and staining specimens)
- unknown fluids - fixatives and storage fluids of unknown composition that may contain toxic substances

Other hazards include:

- cuts from broken glassware
- injuries from attempting to lift heavy jars or tanks
- biohazards that were not eliminated in processing

Note: Many infectious agents are killed by formalin but not all are killed by ethanol. For specimens that have been denatured rather than fixed, handle them with special care.

B. Stabilization of Wet Biological Specimens

1. *What specimen characteristics should I document prior to stabilizing a wet specimen?*

Be sure to document the natural conditions and features of the specimen. Note anything that may be changed by stabilization. The details of such documentation typically follow standard practices of individual disciplines. Examples include color, markings, weight dimensions, sex, reproductive condition, age, and physical condition. It's a good idea to take dimensional measurements when the specimen is still fresh. Fixation or denaturation may cause it to distort, shrink, or swell.

Documentation about specimen history can be useful in determining the integrity of the specimen for research or its safety for use in interpretation. Such information may include the condition of the specimen, environmental conditions, and stabilization methods and materials, to name but a few.

2. *What should I know about the stabilization process for wet specimens?*

A variety of chemicals can be used for collecting, fixing, and preserving specimens. The choice may be based on the kind of organism involved, disciplinary standards, intended use, and legal possession.

Formalin is a common fixative for soft tissues. Some specimens, such as fish larvae and eggs, are usually fixed and stored in formalin solutions.

Because formalin fixation yields acidic solutions that are harmful to calcium-based materials (shell, bone, and the calcium present in many tissues), formalin solutions may be:

- buffered
- subsequently replaced with an alcohol solution

To avoid potential deterioration in the fixative, some specimen parts may be removed prior to fixation (for example, skulls of vertebrates) then preserved by other means.

3. *Is formalin used with all wet biological specimens?*

No. Some specimens are denatured using alcohol, rather than treated with a fixative. This:

- facilitates extracting nucleic acids from specimens for biochemical

analyses

- avoids the safety hazards associated with formalin
- averts potential decalcification

The technique works especially well for small specimens, such as insects.

Note: You still may find it necessary to transfer the specimens to a fresh alcohol solution during the processing stage. This depends upon the degree to which displacement of water from the specimens has altered the concentration of the alcohol.

4. *How do I protect specimens during stabilization?*

During stabilization you should:

- Ensure the relationship of the specimens to their data.
- Perform the stabilization treatment in a timely manner to minimize the decomposition of the specimen.
- Use trained people to perform the work.
- Use deionized or distilled water to mix fixatives.
 - Tap water, water from local ponds and streams, or saltwater can be sources of fluid contamination.
 - Contaminants may jeopardize preservation by changing the pH of the solution (this can impede fixation or denaturation).
 - Soaking specimens in certain salt solutions has been used as a method to reverse formalin fixation.
- Use fixative or alcohol solutions for specimens for the same taxa collected at the same place and time.
 - This will ensure uncompromised utility of the specimens for biochemical analyses.
 - Components leached from one set of specimens can contaminate the next set.
- Do not crowd specimens in fixative or alcohol solutions.
 - The amount of water that leaches into the fluid from the specimens will weaken the concentration of the solutions.
 - Crowding also may lead to mechanical damage to the specimens.

Other things to remember include:

- **Alcohols are flammable.** Take special precautions to protect the specimens from fire.
- **Fixation with formalin may not work well at low temperatures.** This is because of the potential for polymerization of formaldehyde.

- **High relative humidity** will rapidly decrease the concentration of both alcohols, which rapidly take up moisture from the air.
- **Low temperatures** will cause polymerization of formaldehyde in formalin solutions used as storage fluids.
- **Improper handling** of specimens during processing, and crowding specimens in containers can result in mechanical damage.

PRIORITY 1	PRIORITY 2	PRIORITY 3
Neglect	Physical Forces	Criminal Activity
Contaminants	Light	Water
Fire		Pests
Inappropriate T		Inappropriate RH

Table T.7. Impact of the agents of deterioration on specimens during stabilization for wet biological specimens

5. *What are the health and safety issues concerning stabilization of wet specimens?*

Health and safety concerns during stabilization involve:

- external parasites
- diseased carcasses
- decomposing tissues
- toxicity or flammability of the chemicals used in the stabilization process

To protect yourself, other staff, and researchers, use:

- appropriate engineering controls, such as biohazard hoods and chemical vapor hoods
- properly chosen gloves and other protective clothing

These are the best means to ensure your safety. If engineering controls are unavailable (as is often the case during field stabilization), you may need to use additional personal protective equipment.

Remember: Before you use a respirator, you must have a medical exam, training, and be fit tested. See COG 2/13 “An Introduction to Respirator Use in Collections Management” for additional information.

C. Processing of Wet Biological Specimens

1. *What general information about processing should I be aware of?*

- In the past, specimens removed from formalin solutions for transfer to alcohol solutions were first soaked in water for prolonged periods to remove the excess fixative. Today, prudent practice involves briefly soaking the specimens in various concentrations of the final storage fluid (for example, 20%, then 40%, then 60%, then 70% ethanol for specimens that will eventually be stored in 70-75% ethanol).
- Many institutions select 70-75% ethanol as the storage fluid of choice. Institutions that lack a Federal permit for undenatured (potable) ethanol can use a 45-55% isopropanol solution. However, ethanol is the best storage fluid because it preserves the utility of the specimens for many biochemical and other analyses. Isopropanol use can also be problematic, as it:
 - has been shown to change the measurements of some specimens (via shrinkage)
 - renders some specimens transparent
 - may soften bone
 - is difficult to mix thoroughly with water

Note: To apply for a Federal permit for undenatured ethanol, contact the U.S. Department of the Treasury's Tax and Trade Bureau, National Revenue Center at:

U.S. Department of the Treasury
Tax and Trade Bureau
National Revenue Center
550 Main Street Suite 8002
Cincinnati, Ohio 45202
(877) 882-3277
www.ttb.gov/nrc/index.htm

- Some vertebrate material will be subjected to clearing and staining techniques to expose the position of skeletal elements within the body of the specimen.
- Some specimens with delicate or soft parts may be secured to a support system (for example, glass plate). This will protect the specimen and make it easy to handle during examination.
- Final preparation of wet specimens involves placing the specimen or its parts in a container, such as a glass vial or jar, or a stainless steel or plastic tank.

Processing requires special expertise, time, & facilities. You must possess ALL of these resources before accepting collections that may require processing. If you don't, you'll have a backlog of unprocessed or partially processed specimens of limited use.

2. *How should I label wet specimens?*

Depending on the specimen(s), you can label specimens with:

- tags tied to the specimen
- labels attached to the outside of the container
- labels placed inside the container, but facing out for visibility

If you place multiple, individually cataloged specimens within the same container, be sure that each specimen has a tag with at least its catalog number.

Remember: Any labels that you place inside the container must be resistant to fluid damage (both label and ink).

3. *What materials should I use to label wet specimens?*

Label Materials

- Use good quality, long-fibered, cotton rag labels. These hold up remarkably well in fluid collections.
- The only synthetic polymer that seems to withstand the fluid environment is non-woven polyester, such as Tyvek®.
- Don't use:
 - **Paper treated with formaldehyde** to make it fluid-resistant. This can cause slight acidification of storage fluids.
 - **Metal labels** can corrode and may also cause mechanical damage to specimens. Keep in mind that leg bands and ear tags should remain with specimens, even when stored in fluids.

Inks and Other Media

- Carbon inks do not fade over time. Use only carbon-based, black inks on specimen labels, including barcode labels.
 - Commercial, black printing inks are usually carbon-based, as are most laser and photocopier toners.
 - Laser and photocopiers also apply the toner with a certain amount of heat, which helps fuse the toner particles to the paper.
- Liquid inks vary greatly in quality. Black inks for labeling wet collections should be drafting inks designed for writing on drafting film, using technical pens.
 - These tend to be carbon-based inks with a neutral pH that adhere well to almost any surface.
 - Such inks do not dissolve in water, alcohol, or formalin solutions.
 - **Note:** They do not have to be used in technical pens or on drafting

film during specimen labeling.

- Black liquid inks in some fiber-tipped pens are acceptable for use in labeling wet specimens. Be sure to choose pens with carbon-based inks, and test:
 - how long it takes for the ink to dry so that it will not smear
 - how well the ink resists water, alcohol, and formalin
 - how well it resists smearing or loss from abrasion when wet with any of these fluids

Attachments for Labels

- Cotton thread or string will work well to attach labels to fluid-preserved specimens.
- Don't use:
 - wire or any other metal fasteners
 - plastics

4. *What agents of deterioration affect wet biological specimens during processing?*

The primary agents of deterioration for wet specimens during processing are:

- **Neglect**, including staff with insufficient knowledge and skills to fulfill processing techniques. This can render a specimen useless.
- **Contaminants** can result from:
 - diluting storage fluids with tap water (which often contains a variety of treatment chemicals)
 - using denatured alcohol or low-grade alcohols that contain impurities
- **Light and ultraviolet radiation** can damage wet specimens during processing while out of their fluid medium or while in transparent containers.
- **Fire** is a hazard with both ethanol and isopropanol.

Other agents of deterioration affecting wet biological specimens include:

- **High relative humidity** will rapidly decrease the concentration of both alcohols, which rapidly take up moisture from the air.
- **Low temperatures** will cause polymerization of formaldehyde in formalin solutions used as storage fluids.
- **Improper handling** of specimens during processing, and crowding specimens in containers can result in mechanical damage.

PRIORITY 1	PRIORITY 2	PRIORITY 3
Neglect	Physical Forces	Criminal activity
Contaminants	Inappropriate T	Water
Light	Inappropriate RH	Pests
Fire		

Table T.8. Impact of agents of deterioration during the processing of specimens for wet collections.

5. *How should I handle wet biological specimens during processing?*
- To protect wet specimens during processing (or at any other time), be sure to:
- Keep fluid-preserved specimens wet with the appropriate fluid at all times.
 - Keep fluid containers closed and sealed when not removing or replacing specimens. The volume and concentration of fluid preservatives will change with evaporation.
 - Avoid open flames and sources of heat and sparks. Use lighting and other electrical installations that are designed to be explosion-proof.
 - Ask for help when handling large jars or tanks and manipulating large specimens.
6. *Can I keep some wet biological specimens in formalin?*
- Yes. Formalin is sometimes used as a storage fluid as well as a fixative. This is less common today due to the health hazards associated with formaldehyde, which is considered to be a carcinogen.
- However, formalin is still a common storage fluid for some soft tissues. For example, fish larvae and eggs are usually fixed and stored in formalin solutions. Unlike alcohol, formalin will not dehydrate fish larvae cells causing them to become distorted and difficult to dissect.
- Most other specimens can be transferred to alcohol after fixation. If you prefer that a specimen remain in formalin, you may want to buffer the solution if there is a potential for excessive hardening or decalcification of the specimens. You do not need to buffer alcohol solutions.
- If you need to buffer a formalin solution, **do not use alkaline chemicals such as calcium carbonate and borax.**
- These alkalis simply raise the pH of a solution, and allow tissues to soften.
 - They can also cause fixation to reverse.

- Their impact on the pH of the solution may be short-lived.
- True chemical buffers act continuously to stabilize the pH of the solution to a pH determined by the choice of buffering agent.

An acceptable buffer for formalin is composed of monobasic sodium phosphate monohydrate and dibasic sodium phosphate anhydrate.

Remember: The rationale for keeping a particular specimen in formalin or transferring it into an alcohol solution might be related to its intended research use.

7. *How do I transfer wet specimens from formalin to an alcohol solution?*

If you transfer specimens from formalin to alcohol, be sure to soak them in increasing concentrations of the storage fluid. This prevents damage from osmotic pressures in the tissues. Osmotic pressures result when you move specimens directly into the final concentration of the storage fluid (alcohol) from a formalin solution, which is mostly water. Prolonged soaking in water, rather than graded alcohols, causes two problems:

- fixation may be reversed, allowing the specimens to begin to rot
- specimens may swell as they become hydrated

Note: You can determine alcohol concentrations by using an alcohol hydrometer.

Test Strips

- During the transfer process, you can use formaldehyde test strips to determine approximately how much fixative remains in the solutions.
- There should be some residual fixative in the final storage solution (even though this has potential to acidity the alcohol) because fixation involves an equilibrium reaction.
- If trace amounts of the fixative are not detected, it may mean that specimens were not originally fixed properly or that fixation was reversed during the transfer process.

Water

- Alcohols are usually diluted with water when used as a transfer or a storage medium.
- **Tap water is not acceptable for mixing these solutions:** it contains water treatment chemicals that may have an impact on specimen preservation and utility.
- Distilled water exposed to carbon dioxide in air tends to be acidic.
- **The best choice is deionized water,** which is pH neutral and should contain no harmful impurities.

Mixing

- Don't mix an alcohol/water solution simply by using fixed volumes, such as 70 parts alcohol to 30 parts water. The result will rarely be 70% alcohol because the concentration is temperature dependent.
- Determine the volume percent concentration of the alcohol.
 - You can use an alcohol hydrometer (available from most laboratory supply companies). Ambient and fluid temperatures must be at about 20°C/68°F.
 - Ideally, measure concentrations using a density meter (also available from laboratory suppliers).

Concentrations

- Check the concentration of alcohols used for specimens that are not treated with a fixative.
- You might have to correct the concentration of the alcohol to create an appropriate storage fluid.
 - If the concentration of the alcohol solution is very low, it may be prudent to replace the fluid entirely, even though this will result in loss of the materials already leached from the specimen.
 - See *COG 11/5* for methods to correct the alcohol concentration.

8. *Can I transfer wet biological specimens from ethanol to isopropanol?*

No. Do not transfer specimens in ethanol to isopropanol. This change will damage the specimens. Researchers have experimented with transferring specimens from isopropanol to ethanol after conditioning the specimens in increasing concentrations of ethanol. However, this process requires additional research before it can be endorsed as a practice.

9. *What about clearing and staining specimens?*

Some specimens are cleared and stained before being placed in storage fluids, and vice versa. The use of clearing and staining chemicals requires specialized knowledge. The choice of final storage fluid will be determined in part by the solubility of the stains used in the process.

Often the final storage fluid is glycerol. Glycerol supports mold growth, so collection staff sometimes have to mix various chemicals, such as thymol, as anti-fungal agents. These chemicals add to the complexity of preservation problems. When the stains used are not alcohol soluble, a simple way to prevent mold growth is to store the specimens in a mixture of glycerin and ethanol.

10. *Can I keep different wet biological specimens together in the same container?*

No. Various specimen components leach into the fluid. If you mix specimens you risk cross contamination. **This will damage the utility of the specimens for biochemical studies.**

Don't store specimens together in the same container unless they are of the same species or lot and were collected in the same place and at the same time.

11. *How should I document a wet specimen's condition during processing?*

As previously discussed, utilize a condition report. In addition to documenting standard conditions, you may want to also note:

- condition of labels and the label attachments to the specimen
- fluid characteristics
 - color
 - transparency
 - pH
 - formalin concentration
 - alcohol concentration
 - fluid-to-specimen ratio
- condition of the container and closure (corroded, poorly sealed, etc.)

Your collection may require a more detailed condition examination. You also may require additional information concerning appropriate care for certain specimens. Discuss these needs with your regional/SO curator. He or she can assist you to hire a natural history conservator to conduct a Collection Condition Survey (CCS) of your collection. For additional information concerning a CCS, see Chapter 3, Section D.

You might find it helpful to include the name of the individual who prepared the specimen in your condition report as well.

12. *What health and safety concerns should I be aware of during processing?*

Special health and safety concerns during processing are the:

- toxicity or flammability of the chemicals
- potential for ergonomic injuries when handling large containers

Engineering controls, such as chemical vapor hoods, along with proper gloves and other protective clothing are the best means to ensure your safety when handling hazardous chemicals. If engineering controls are unavailable, use additional personal protective equipment. **Note:** The use of respirators requires a medical evaluation, training, and regular fit testing. See *COG 2/13*.

To protect yourself, other staff, and researchers, you should also:

- keep spill cleanup kits on hand for all chemicals used in collection processing
- place large tanks on dollies
- use carts to move large glass jars and smaller tanks

13. *What do I need to know about loans of wet specimens?*

For loan shipments, collections staff usually prepare wet specimens by:

- individually wrapping specimens with cotton gauze that has been saturated with the appropriate fluid preservative

- sealing them in multiple plastic bags, so there's minimal risk of fluids affecting the shipping container

Because wet specimens may not have any information other than the catalog number, you may be required to provide additional information about the specimen for the user. Such information typically includes at least the collecting locality and date, and the fluid in which the specimen should be housed while on loan.

In addition, when packing and shipping specimens preserved in fluids you must:

- include instructions about the type of fluid preservative to be used with the specimens
- insert and seal the bagged specimen in at least one additional polyethylene bag, along with an address label that is visible through the second bag
- place the bags in a sturdy, well-sealed shipping container that has been cushioned on the interior to help protect the specimens during shipment
- comply with all laws and regulations regarding the shipment/transport of biological specimens, rare or endangered species, and hazardous chemicals

Notes:

- As long as you use the shipping method described above (specimens wrapped in cotton gauze saturated with solution and inside plastic bags), your shipment should not contain fluid in an amount to be considered HAZMAT by the DOT. As a result, unless the specimen itself was hazardous, your shipment shouldn't be subject to the Hazardous Materials Regulations, noted previously in this appendix.
- Some commercial shippers (such as Federal Express) do not accept dead animals of any type, including scientific specimens, for transport. Consult with your shipper in advance about any special provisions or requirements of this nature.

D. Storage of Wet Biological Collections

1. *Where should I locate storage?*

You may find it necessary to situate wet collection storage along an exterior wall. Such a location can help mitigate the impact of an explosion on the rest of the building. Note that placement and structural features may be controlled by local building codes. As with all collection storage areas, wet collections should be located where you **can:**

- control access
- organize the collection in a logical manner

- monitor and control the environment

Off-site facilities, basements and attics, and irregular or fragmented spaces are not good choices. Locating collections in such areas does not serve the interests of good collection management, care, or use.

When planning a new wet collection storage area, be sure to consult with your regional/SO curator, regional structural fire management officer, and park staff such as the structural fire management officer, fire inspector, brigade captain, and safety officer. Such NPS staff can assist you with planning a facility that meets both NPS safety and curatorial requirements.

2. *What agents of deterioration pose the greatest threat to wet collections in storage?*

The agents of deterioration that pose the greatest risks in storage are: light, neglect, inappropriate temperature, contaminants, and fire (Table T.9).

- Neglect includes:
 - the improper use of storage equipment
 - careless handling of specimens
 - lack of familiarity with collection organization and arrangement systems
 - failure to monitor storage environments, fluid levels, and container condition
 - mixing of different preservatives or not maintaining the proper concentration of preservative when topping off fluids
- Visible and UV light trigger reactions that can result in changes in fluid quality that may have in impact on specimen preservation.
- Temperature fluctuations cause pressure changes inside storage containers that loosen lids and allow fluid to evaporate.
- Deterioration of containers and closures (gaskets) can result in specimen contamination.
- Collections stored in alcohols can be fire hazards.

PRIORITY 1	PRIORITY 2	PRIORITY 3
Neglect	Physical Forces	Criminal Activity
Contaminants		Water
Light		Inappropriate RH

Inappropriate temperature		Pests
Fire		

Table T.9. Relationship of the agents of deterioration to the storage of specimens for wet collections.

3. *Are there any special considerations for storing wet specimens?*

Yes. In addition to the NPS standards listed in Chapter 4: “Museum Collections Environment” and Chapter 7: “Museum Collections Storage,” there are a number of extra requirements for fluid collections. Most of these additional standards are designed to reduce the potential for fire or hazards to staff and visitors from fluid vapors and chemical spills. The following specifications are either required (consult your regional structural fire management officer, local fire marshal, and local building codes) or desirable for storage facilities that house wet specimens:

- Segregate the storage of wet collections from other collection storage, and from all other museum functions (including laboratories where specimens are processed or used in research).
- Store bulk chemicals used in fluid preservation in a separate structure outside of the collection building. If this cannot be done, store chemicals in a room that that is:
 - separate
 - reinforced
 - properly drained
 - properly equipped

Store all flammable bulk chemicals (such as alcohol) in an approved flammables storage cabinet. See Tools of the Trade for product information and firms on GSA schedule.

- Provide separate air-handling systems for wet collection storage, processing, and use areas. Seal the storage areas so that vapor from storage fluids does not contaminate other museum spaces.
- Provide a stable, cool temperature of about 18.3°C/65°F.
- Provide sufficient dehumidification of the environment to keep the RH below 65%.
- Plan to install floor drains and gutters in the room to collect and contain chemical spills.
- Equip all storerooms with heat and smoke detectors, and water-based, automatic fire suppression systems. Ensure regular inspection, testing, and maintenance of the systems.
- Install explosion-proof lighting and electrical systems in rooms that house collections stored in alcohols.

- Filter all incoming and recirculated air to the American Society of Heating, Refrigerating and Air-Conditioning Engineers (ASHRAE) 90-95% level.
- Use UV filters on all fluorescent lighting. Keep specimens in a dark environment when not in use for research.
- If wet collection storage rooms are along exterior walls, you may need to design these as breakout walls. You also may need to reinforce interior walls to help contain potential explosions.
- Provide equipment to properly dispose of chemicals and solutions.

Discuss storage requirements with your regional/SO curator, regional and park structural fire management officers, local fire department, park maintenance staff, park safety officer, park and regional/SO natural resource management staff, and other subject matter experts. Refer to Chapter 4: “Museum Collections Environment” and Chapter 7, “Museum Collections Storage,” *COG 2/18* “Safe Storage and Handling of Natural History Specimens Preserved in Fluid,” and *COG 11/3* “Storage Concerns for Fluid-Preserved Collections” for NPS standards and requirements for fluid-preserved collections storage.

Note: Consult your regional structural fire management officer, park structural fire management officer, local fire marshal, and building codes to see if your jurisdiction has any special requirements for structures that house collections preserved in alcohol or formalin.

4. *What types of storage containers should I use?*

Containers for long-term storage of specimens preserved in fluid must:

- be durable
- be non-reactive towards the specimens and the storage fluids
- seal well enough to prohibit evaporation of the storage fluid
- comfortably accommodate the specimen so that removal and replacement can be done without causing damage (for example, no shoulders on jars or other containers)
- not degrade from environmental agents of deterioration
- be impermeable to oxygen

You can use these containers to store specimens:

- **Glassware**
 - **Borosilicate Glassware** is the best container material for small to mid-sized specimens. It’s very resistant to chemical corrosion. Unfortunately, appropriate sizes of borosilicate jars are difficult to find in the United States. As a consequence, most U.S. collections

house wet specimens in soda-lime glass (glass composed of silica, calcium oxide, and sodium oxide).

- **Soda-Lime Glass** is cheap, readily available glass. It has only fair corrosion resistance. This glass will begin to leach its alkaline constituents into distilled water in a matter of minutes. Since most storage fluids have pHs ranging from neutral to moderately acidic, the glass will probably react with the fluids over time.
- **Flint Glass Containers** are also used to store specimens in fluid. Flint glass is made of much the same ingredients as soda-lime glass. It may also contain other components, including lead oxide. Flint Glass is not particularly resistant to acids.
- **Tanks**
 - Large specimens are usually housed in tanks made of stainless steel, molded polyethylene, or molded polypropylene.
 - Stainless steel tanks will corrode in the presence of the fluids
 - Steel tanks may also corrode along the welds at the seams. Most do not seal well enough to stop fluid evaporation.
 - Plastic tanks can deteriorate from long exposure to acids, alkalis, UV radiation, and the stress caused by large volumes of fluid.
- **Lids, Gaskets, and Seals**

Lids, gaskets, and seals on containers are often a source of contaminants in the storage fluid. As with the containers noted above, stoppers of borosilicate glass are superior, while other types are not as effective:

- Borosilicate glass stoppers that are manufactured to very fine tolerances seal borosilicate jars very well. These have been used in the United Kingdom for many years.
- Stoppers for commercial grade glassware are not as carefully manufactured, and usually will fit only the container for which each stopper was produced originally. As a consequence, mixing stoppers and containers results in poorly sealed jars.
- Metal caps will corrode. Avoid using them.
- Some plastic lids, such as those made of Bakelite, become brittle in the presence of the vapor from the fluids.
- Polypropylene lids with polyethylene liners work reasonably well on most soda-lime and flint glass jars. They constitute one of the least expensive, but fairly effective closure systems.
- Avoid rubber and synthetic rubber gaskets. They will discolor and deteriorate with age. These gaskets also break down when in contact with the fluid preservative (Simmons, 1995). Gaskets of acrylonitrilebutadiene may be an adequate option (Suzumoto, 1992).

When closures are ineffective, your first option should always be to replace the closure, the container, or both. If that is not feasible, you can use 3M[®] brand #5086 clear polypropylene sealing tape with alcohol-resistant acrylic adhesive as a temporary means to reduce fluid loss. The tape is available at stores that sell building supplies.

- **Vials in a Larger Container**

Follow the steps below to store small fluid-preserved specimens:

- Place the specimens in vials filled with the appropriate fluid preservative.
- Close the vials with a permeable material (such as high-loft, non-bonded polyester fiber).
- Place the vials in a larger container filled with the same fluid preservative.
- Seal the outer container with a lid and liner to prevent evaporation.

This storage method protects individual specimens from mechanical damage and unnecessary handling. It also helps insure that any fluid loss around the specimens will be minimal.

IMPORTANT: Be sure that the ratio of specimens to fluid in a container does not exceed 30%. Fluid quality is jeopardized (the concentration drops, as does the pH) if specimen ratios are higher than 30%.

5. *Are there any other storage requirements that I should consider?*

Yes. The best way to store small wet collections is inside a flammable storage cabinet. Larger collections can be housed on shelves, including mechanically operated mobile storage (although these may not be acceptable to some fire protection authorities). Be sure that the finish on the shelving will resist the collection fluids.

Use bins or trays within cabinets or on shelves to organize specimen containers. This will protect the specimen containers from excess handling and disorder.

Equip all shelving units with removable restraining bars to help keep the containers in place in the event of an emergency. Such rails will also provide protection against someone accidentally knocking a jar off the shelf. Vibration and compactor movement pose little threat to these collections, as long as jars do not topple from the shelves as a result of shifts in position.

See *Tools of the Trade* and COG 11/3 “Storage Concerns for Fluid-Preserved Collections” for additional information concerning storage equipment.

6. *What about arranging wet specimens?*

Sometimes you may need to adapt your arrangement patterns. Most fluid-preserved specimens are stored on shelves. You might want to use an arrangement that accommodates a more effective use of available space (such as storing the same size containers on a shelf).

Over-sized specimens are often housed in large, sometimes very heavy containers. Normally, these are stored at or near floor level. Do not store them above head level.

7. *Are there any special health and safety concerns related to storage of wet collections?*

Yes. In addition to threats of fire and explosion, there are the risks of:

- inhalation of vapor
- skin absorption of chemicals

These risks can occur when removing specimens from large containers. Always open containers under local exhaust ventilation, or use appropriate personal protective equipment. You can minimize these risks and ensure that there is little alcohol or formaldehyde vapor in the ambient air if you:

- Design, maintain and use proper general ventilation systems.
- Use specimen containers that seal well.

To reduce the potential for injuries:

- Keep large containers on dollies or casters.
 - Do not store heavy jars or other heavy containers on high shelves.
-

E. Maintenance of Wet Biological Collections

1. *What does maintenance of wet collections include?*

Proper maintenance includes:

- updating information (including deaccessioning [See *MH-II*, Chapter 6: Deaccessioning, for additional information.])
- ensuring fluid quality and levels
- emergency preparedness and response

2. *How do I maintain fluid quality for wet specimens?*

Monitoring

Conduct frequent monitoring of the wet specimens. This includes:

- The visual inspection of fluid levels.
- The use of a digital density meter and temperature correction tables.
 - These tools allow you to determine alcohol concentrations if fluids have evaporated or become exceptionally discolored.
 - **Note:** You can use an alcohol hydrometer to approximate the concentration, but both the fluid and the ambient air temperatures must be 20°C/68°F to achieve accurate results.

Maintaining Fluid Levels

- If room temperatures do not change over time, you can maintain fluid levels by completely filling containers.
- If temperatures change, pressures within containers will cause the lids to loosen
 - This will eventually compromise fluid levels and concentrations.
 - If this occurs, it's best if you maintain fluid levels at a standard distance (at least one inch) below the lip of the closed lid.
 - This allows for the available space to better accommodate changing internal pressures.

Other monitoring considerations include:

- Avoid excessive air. This promotes oxidation of the fluids (acidification of the alcohol).
- Keep all containers filled to the same level. This facilitates inspections for containers that do not seal properly.
- If a container permits fluid loss, replace the appropriate parts (jar, lid, or gasket).
- If the loss of fluid results from use, you'll need to replenish the preservative.

It's vital that you ensure proper fluid levels and concentrations in each individual container housing wet specimens. This requires constant monitoring of fluid conditions and occasional maintenance.

3. *How are fluids lost or compromised?*

Fluids may be lost or altered by:

- defective lids or seals
- changing temperatures that cause closures to loosen
- leaving lids off of the containers for prolonged periods
- removal and replacement of specimens
- spills

In addition, fluid preservatives may become discolored due to:

- unstable gaskets
- corrosion of metal (such as bails, lids, labels, ear tags, leg bands)
- seepage of body fluids (water in the cells, blood, digestive fluids)

- dissolution of specimen pigments
- breakdown of lipids
- polymerization of formaldehyde into milky strings, due to:
 - exposure to low temperatures
 - a change in the pH of the fluid
- contaminants originally present in the fluids (such as minerals from tap water)

The most common problem related to wet collections maintenance is lack of training. Do not attempt to replenish fluids in a collection if you do not have a proper understanding of how to adjust the overall concentration.

4. *How do I replace or replenish the fluid preservative?*

Because the primary environments for wet specimens are the storage fluids, **the quality of those fluids are your main concern.** If fluids evaporate from containers for any reason, the concentration of the remaining fluid is altered. Alcohols evaporate more quickly than the water with which they are mixed. Evaporation results in solutions with low alcohol concentrations and low fluid volumes that no longer fill the jars. The space once filled with fluids is now filled with air. The air fosters oxidation of the alcohol, further changing the chemistry of the solution.

First, fix the problem, even if it means replacing the container. When containers are maintaining fluid levels, the only reason for fluid replacement should be to replenish fluids lost because of specimen use.

Use the following procedures to replenish fluid:

- Determine the concentration of the alcohol in the container.
 - Use a digital density meter and temperature correction tables to determine the concentration of the alcohol in the container. **OR**
 - Use an alcohol hydrometer to approximate the concentration, but both the fluid and the ambient air temperatures must be 20°C/68°F to achieve accurate results. This requires you to:
 - a. take several measurements to determine the true concentration of the reduced fluid in the container
 - b. carefully mix the fluid to ensure that there is no possibility of measuring pockets of especially high or low concentration
 - c. use sufficient amounts of fluid for measurement
- To determine the appropriate concentration of the make-up fluid, use the formula developed by Kelly Sendall and Grant Hughes: $z(x+y) = ax + by$

z = desired concentration

x = height of the fluid in a straight sided container

y = amount of fluid to add (in inches or centimeters)
a = measure concentration of the fluid (percent)
b = the concentration of the fluid being added (percent)

5. *Are there any other ways to adjust fluid concentrations?*

Yes. You also can adjust the concentration by simply adding 95% alcohol to the appropriate level in the container and then checking the concentration with the density meter. If the new concentration reaches the target range (70-75% ethanol) or is higher, that is acceptable. Higher concentrations are not likely to damage the specimens, but concentrations below the optimum range will permit deterioration.

6. *When should I replace the fluid?*

You may need to replace the fluid if any of the following circumstances occur:

- If the alcohol concentration in a container is 20% or less and there is still a fairly large amount of fluid in the container, it may not be possible to bring the concentration back to the appropriate level. If that is the case, you may need to replace at least some portion of the fluid.
- If the addition of 95% alcohol to the fluid in the container does not bring the concentration to the appropriate range or higher, you may need to replace the fluid.
- If the fluid contains sediment or other particulate residue that is shown by analysis to be damaging to the specimen, you can filter the fluid to remove the sediment and then return the fluid to the container. If the sediment is an indication of an ongoing deterioration of the fluid or specimen, then you may need to replace the fluid.
- If specimen containers are crowded with specimens the result will be poor fluid quality. To fix this:
 - Separate the specimens into additional containers.
 - Correct the concentration of the fluid in the initial container.
 - Use new storage fluids in the additional containers.

The fluid surrounding a specimen contains components leached from the specimen. Therefore, loss of specimen material results if you completely replace fluids. You can expect additional leaching as the specimen(s) and replacement fluid reach equilibrium. Replace fluids only under very special circumstances.

Note: Specimens that have become deformed when fluids have evaporated completely may no longer be useful for morphological studies. They are often of limited use after rehydration. However, in the dry state, they may be very stable. They also may be useful for biochemical studies, depending upon the type of fluids that were used originally.

7. *Should I be concerned if some fluids are discolored?*

No. Fluids are often discolored; this is not normally a cause for alarm. However, consult a conservator if:

- a fluid has developed a very dark color, and
- there is any evidence that a lid, gasket, or label is undergoing

deterioration and may be leaching components into the fluid

The conservator or a conservation scientist should determine the appropriate treatment. Do not replace the fluid before you have researched the nature of the deterioration.

8. *When should I consult a conservator?*

Never take any action that might compromise the integrity of research specimens. If specimens are damaged, stabilize the material by non-interventive means. This approach is usually preferable to treatment to repair the damage. For example, you can leave detached parts separate as long as they are kept in the same container with the original specimen. Be sure to separately label the parts to indicate their source.

If a condition indicates active deterioration, the specimen may need treatment to halt further decay. An example might be a metal label that has corroded and become attached directly to a specimen by the corrosion products. Because the corrosion and the specimen damage will continue in a fluid environment, it may be best to remove the label and the corrosion salts, then stabilize the label separately. **Do not attempt this type of interventive treatment. Call a professional conservator for assistance.**

9. *Are there any health and safety concerns related to maintenance of wet collections?*

In general, the safety concerns are the same as those for stabilization and processing of wet collections. Remember to utilize proper waste disposal of any fluids that are replaced during maintenance activities. Use proper engineering controls and personal protective equipment. Always move large tanks and other containers on dollies. Move smaller containers on carts.

10. *What should I know about emergency preparedness, response, salvage, and long-term recovery?*

Potential emergencies include chemical spills and leaks, fire, and explosions. Fluid collections can also be damaged by floods and earthquakes, especially if shelves are not properly secured and specimen containers are not protected by restraining bars on the shelving units.

Be sure that your park's structural fire brigade, law enforcement staff, local fire department, emergency medical technicians, and all other emergency response personnel know of all potential hazards and their locations.

The safety concerns that arise during emergency salvage are noted in Chapter 10: Emergency Planning and *Help! A Survivor's Guide to Emergency Preparedness*, available from the Alberta Museums Association. Ordering information is available on the association's website at <www.museumsalberta.ab.ca>.

If specimen containers have broken and fluids have been lost, the most important salvage step is to keep the specimens damp. Ideally, you should keep them damp using the same kind of fluid in which they were stored prior to the emergency. If that's not possible, at least bag (double bag if you can) the specimens in polyethylene with a small amount of deionized or distilled water. Add a little alcohol to help limit the potential for biodeterioration.

Note: Following an emergency, be sure to consult a conservation professional. Complex, extensive treatments may be needed as part of the long-term recovery process. If containers have been broken or were poorly sealed the contents may no longer have utility for some scientific research.

11. *Do I need to document maintenance activities such as replacing fluids?*

Yes. All adjustments of fluid concentration and fluid replacements are essentially specimen treatments that you should fully document in writing. If you discover that containers or labels have contaminated a specimen, note this as well. Any contamination is likely to affect the long-term preservation and the utility of the specimens for research.

During emergency salvage operations, it's acceptable for you to eliminate individual specimen reports, as long as you document all steps in the overall immediate salvage (in writing and in some imaging system). You should record specific damage to particularly valuable specimens and specimens on loan from other museums, and note the specific salvage methods used, as they may be important for insurance purposes.

SECTION V: BIOLOGICAL LOW-TEMPERATURE COLLECTIONS

A. Overview

1. *Why are specimens preserved at low temperatures?*
2. *What low temperatures are used?*

Specimens are maintained at low temperatures to preserve:

- soft parts for various biochemical analyses
- whole organisms in a viable (able to live and grow) state

Cold Storage includes temperatures above the freezing point of water (0°C/32°F), but not above about 8°C/46.4°F (a range of 2°-8°C/35.6-46.4°F is recommended). Cold storage is used to extend the shelf life of microorganisms prepared by specialized lyophilization (freeze-drying) techniques.

Freezer Storage includes temperatures between 0°C/32°F and -80°C/-112°F. Although such temperatures are often used for temporary storage, expansion of water in cells, ice crystal formation, and dehydration can damage biological materials stored at these temperatures.

Ultracold Storage at about -80°C/-112°F is used for short-term preservation of non-viable samples, such as animal tissue samples.

True Cryogenic Storage includes temperatures that are usually below -130°C/-202°F (the exact temperature is usually determined by the sensitivity of the specimens). -130°C/-202°F is the maximum temperature for long-term stability of plant and animal cells and **-150°C/-238°F or lower is considered to be optimum for preservation.**

You cannot achieve true preservation of fresh biological material at temperatures between 0°C/32°F and -130°C/-202°F, as:

- fresh material will undergo cellular disruption because of expansion of water in the tissues
- dry biological material will be degraded by an increase in the rate of deterioration of lipids and damage from residual moisture

Note: Increased rate of deterioration of lipids, and increased potential for biodeterioration are hazards for many materials stored at temperatures between 8°C/46.4°F and 16°C/60.8°F.

Lyophilization and cryogenic storage options generally require pre-treatment of the specimens using a cryoprotectant chemical.

3. *What specimens are preserved at low temperatures?*

- Plants
 - Non-vascular (strains of fungi, including yeasts)
 - Vascular (cell lines, seeds, cloned probes, other samples)

- Protists
 - Some algae
 - Protozoa (especially parasitic strains)
- Viruses
 - Plant, human, and animal viruses
 - Cloned viral genomes
- Bacteria
 - Bacterial strains
 - Bacteriophages
 - Plasmids
- Animals
 - Tissues (dissected organs, muscles)
 - Cell lines
 - Blood and blood components (whole blood, serum, plasma, antisera)
 - Semen
 - Venom
 - Other samples (cloned probes, isolated proteins and nucleic acids, cell suspensions)

Note: The largest organisms that can be preserved in a viable state are some insects.

Cryogenic collections are often samples specifically set aside for destructive analyses, using tissues from voucher specimens in traditional collections. Such cryogenic samples are ancillary or supportive to the voucher specimens. However, ancillary collections may include one or more tissue samples from individual specimens, or include samples from more than one collection or institution. Sometimes there is no voucher specimen. Because of these issues and the fact that various tissues may be indistinguishable without biochemical analyses, you need to ensure that your records are extremely accurate.

4. *What agents of deterioration affect low-*

Inappropriate temperature (including temperature fluctuations) is the primary agent of deterioration for low temperatures collections.

temperature collections?

- **Cold Storage** at temperatures of 2-8°C/35.6-46.4°F will extend the life of some freeze-dried cultures that are reasonably resistant to temperature changes, but may be damaged by temperatures outside this range.
- **Ultracold Storage** at temperatures around -80°C/-112°F:
 - will slow the rate of deterioration of tissue samples preserved for DNA analysis but will not stop the deterioration
 - the rate of deterioration increases when samples are repeatedly removed from storage for use at higher temperatures
- **Cryogenic Storage** at temperatures below -130°C/-202°F will preserve specimens well, but is expensive to install and maintain.

Cryogenic Specimens cannot be stored at temperatures above about -130°C/-202°F and below 0°C/32°F, as this will destroy their utility. To prevent such damage, make sure that you have backup systems in place so that cryogenic units can maintain the appropriate temperatures at all times.

The other agents of deterioration in addition to inappropriate temperature include:

- **Neglect** includes a lack of knowledge and skills, failure to follow standards or provide adequate documentation, apathy, lack of administrative support and resources. Common instances of neglect are:
 - marking ampoules illegibly or inaccurately
 - failing to link tissues, cell lines, etc. to identifiable voucher specimens
 - failing to monitor storage environments to ensure that appropriate temperatures are maintained constantly
 - failing to provide adequate backup systems to prevent temperature increases
 - the lack of temperature control during sample use
- **Contaminants** can damage low-temperature collections. Do not allow specimens to come into contact with:
 - other specimens, directly or indirectly (for example, transfer through handling)
 - any non-sterile surfaceContaminants can destroy a specimen's utility for many types of research. Maintain pristine work areas and utilize appropriate biofilters, proper storage containers, and appropriate handling methods to eliminate specimen contamination.

- **Physical Forces** can damage or destroy low-temperature collections.

- Inappropriate ampoules or ampoules containing excessive specimen tissues can burst when removed from liquid nitrogen. (Liquid nitrogen is used to both transport and store some materials preserved at low temperatures.) This will destroy the specimens and pose chemical, physical, and biological hazards to human safety.
- Freezing at temperatures above cryogenic levels will permit moisture in tissue samples to form ice crystals that will damage tissue structures.
- **Criminal Activity** is usually not a major threat to collections stored at low temperatures. However, some low-temperature collections may require additional security measures if they include:
 - viable organisms that are pathogenic to humans or human resources (for example, to agricultural plants and animals, or water supplies)
 - tissues that may contain pathogenic organisms in a viable state

Institutions that maintain such material must possess permits and sufficient security to ensure that their holdings cannot become a danger to public health.

5. *What health and safety concerns are related to low-temperature collections?*

As with fresh or semi-fresh biological material, there is the possibility of that **human pathogens are present in low-temperature materials**. These may include either the specimens themselves or as infectious agents in the specimens. Other potential hazards include:

- **Liquid nitrogen**, which is the best storage medium for cryogenic preservation. If you use liquid nitrogen, you need:
 - special personal protective equipment (PPE)
 - special building ventilation systems
 - appropriate ampoules that are resistant to breakage resulting from thermal changes
 - possible replenishment of liquid nitrogen, depending on the system used

You also may need to equip your building with special piping for delivery of the liquid nitrogen to cryogenic units.

- **Dry ice** (solid carbon dioxide) is sometimes used to protect material removed from cryogenic storage. If you use dry ice:
 - utilize special containers and personal protective equipment
 - do not use dry ice in confined closed areas because of respiratory concerns involving excessively high atmospheric quantities of carbon dioxide

Don't store dry ice in sealed rigid containers. This can cause an explosion when the containers are opened. Use vented containers.

- **Ethylene oxide** is used in some preparation procedures to sterilize the preparation chambers. This chemical requires:
 - special exhaust ventilation
 - personal protective equipment
 - specialized training

To reduce risks to you, other staff, and researchers, be sure to utilize:

- proper procedures
- well-designed preparation, storage, and research facilities
- biohazards hoods for any work with specimens preserved at low temperature
- personal protective equipment, including long insulated gloves and face shields when working with material stored at cryogenic temperatures
- properly fitted respiratory protection, and proper gloves and other protective clothing when
 - handling microorganisms
 - working with liquid nitrogen and ethylene oxide

B. Stabilization and Processing of Low-Temperature Collections

IMPORTANT NOTES CONCERNING LOW-TEMPERATURE COLLECTIONS:

Stabilization of low-temperature collections should not be the responsibility of the park's collection staff. Researchers, research designs, and material utilization will control the conditions of biological specimens and specimen parts intended for low-temperature preservation. Stabilization of such material is beyond the control or operations of the park.

Low-temperature collections can pose serious health and safety risks. They can also involve significant resource commitments (time, money, personnel, space, facilities, and equipment) for operating specialized low-temperature equipment.

No individual should be involved with stabilization of biological materials for low-temperature collections without first receiving specialized training. Such training far surpasses any guidance provided in this appendix. Therefore, the following information attempts to focus on the processing, storage, and maintenance of low-temperature collections. Be aware that serious health and safety risks are still present with these stages of preservation.

Finally, considering evolving issues of national security as they relate to the legality of some preserved biological materials (viruses, spores, toxins, etc.), special permits and security clearance may be required for any possession, handling, or transport of hazardous biological materials. The information contained in this appendix does not address any stage of preservation of such materials.

1. *How should I label low-temperature collections?*

Refer to the previous general discussions of labeling specimens, as well as those noted in *MH-II*, Appendix J, Section K, Natural History Specimens. Other considerations specific to low temperature include:

- **Condensation** on cold surfaces, water solubility of some inks, and impervious surfaces (like plastic ampoules) can create the problems for using inks in low-temperature collections. Staff sometime use alternative methods such as soft pencils or mechanical inscription.
- **Carbon-based, black inks** are the only type of inks that you should use on specimen labels. Carbon inks do not fade over time.
 - Commercial, black printing inks are usually carbon-based.
 - Most laser and photocopier toners are usually carbon-based.
 - Laser and photocopiers apply the toner with a certain amount of heat, which helps fuse the toner particles to the paper.

Liquid inks vary in quality. A good choice is **black ink designed for writing on drafting film**, using technical pens. These tend to be carbon-based inks with a neutral pH that adhere well to almost any surface.

- **Fiber-tipped pens.** Black liquid inks in some fiber-tipped pens are acceptable for labeling specimen containers.
 - Be sure to choose pens with carbon-based inks.
 - Fiber-tipped pens that contain colored or black dye inks are also available.
 - Many of these products may not function well if water from condensation is present.
 - Cold temperatures will slow the fading of the dyes in these inks, but rate of fading will depend upon both the temperature and the humidity level in storage.
 - Time spent out of the low-temperature environment will permit the inks to fade quite rapidly.
- **Testing of Inks.** Test inks to see:
 - How long does it takes for any ink to dry so that it won't smear?
 - How well does it resist smearing when wet?
 - What's the resistance of the ink to various fluids, minimal abrasive

forces, and to prolonged exposure to UV radiation?

Avoid any ink that fails such tests.

- **Bar Coding** is often used for the specimen and sample vials used in low-temperature preservation. Bar coding facilitates rapid inventory and reduced risk of mismatching specimens with data.

2. *What should I know about loans of low-temperature collections?*

For information concerning incoming loans, see *MH-II*, Chapter 2, Section P. For information concerning outgoing loans, see *MH-II*, Chapter 5. You should also be aware of the following additional standards that pertain to loans of specimens preserved at low temperature:

- The use of hazardous biological materials may be restricted.
- Do not loan entire holdings of a taxon for use at a single time (it may be necessary to culture a new colony before allowing specimens to be sent).
- Commercial shipments of hazardous biological materials must be in compliance with all Federal and State regulations, including the Hazardous Materials Regulations (49CFR, Parts 171 through 180).

3. *What agents of deterioration affect low-temperature collections during processing?*

The primary agents of deterioration during processing are:

- Insufficient knowledge and skills (neglect) that can render a specimen useless.
- Contaminants can result from poor handling techniques. Both physical damage and contamination can result from removing improperly sealed ampoules from some types of cryogenic storage.
- If liquid nitrogen has leaked into specimen containers, the containers may burst when exposed to warmer temperatures.
- Inappropriate temperatures can rapidly destroy the utility of specimens preserved at low temperatures.

These agents of deterioration are shown in Table T.10., below.

PRIORITY 1	PRIORITY 2	PRIORITY 3
Neglect	Criminal activity	Light
Contaminants		Water
Physical Forces		Fire
Inappropriate T		Pests

		Inappropriate RH
--	--	------------------

Table T.10. Impact of agents of deterioration during the processing of low-temperature specimens.

<p>4. <i>How should I handle specimens during processing?</i></p>	<p>The basic rules for properly handling, moving, and placing specimens preserved at low temperature are:</p> <ul style="list-style-type: none"> • Keep specimens as close as possible to storage temperatures at all times. Use insulated containers, small tanks of liquid nitrogen, or containers with dry ice to move specimens. Use carts to move these containers. • Some institutions require that handling tissue samples be done in a chest freezer. • Keep storage freezers or tanks closed when not removing or replacing specimens. Make sure that all removal/replacement is done quickly. • Provide dedicated workspace, stable work surfaces, appropriate local exhaust ventilation, and appropriate personal protective equipment. • Provide UV-filtered lighting with good color rendering capacity (a color rendering Index of 90 or higher) and preferably, lighting free of most infrared (heat) radiation. • Maintain clean and orderly work areas and eliminate unnecessary risks such food, beverages, and other potential contaminants. • Maintain sufficient space for each specimen. • Handle only one specimen container or sample at a time. • Avoid unnecessary handling.
<p>5. <i>How should I pack and ship specimens for loans?</i></p>	<p>Refer to the general packing and shipping guidelines listed in Chapter 6, “Handling, Packing, and Shipping Museum Objects.” Specimens preserved at low temperatures require additional precautions. Be sure to:</p> <ul style="list-style-type: none"> • Provide an appropriately sealed and insulated container that will maintain the required temperature for the specimens/samples. • Provide appropriate invoices and shipping documentation (including hazardous materials warnings and endangered species documentation where pertinent) to avoid unnecessary opening of the container. • Provide instructions on how to properly open the container and remove the specimens. • Provide instructions to the recipient about the type of preservation to be used for the specimens; especially the required temperature.

- Send loans by overnight express at the beginning of the week to ensure better control and to minimize risks of thawing prior to delivery.
- Send frozen materials in heavily insulated containers with “ice-packs.”

Note: Dry ice is considered to be a dangerous good. Do not use dry ice in a commercial shipment unless you have received DOT-approved training in packing, labeling, and shipping dangerous goods **OR** hire a certified HAZMAT shipping contractor to properly pack, prepare, and label the shipment for transport.

- Be sure that all shipments fully comply with Federal regulations regarding:
 - shipping documentation
 - the shipment of endangered species
 - the shipment of hazardous materials.
- Ensure that the specimens are properly packaged, to protect both the specimens and anyone handling the shipment.
- Mark outside of shipments as “FROZEN MATERIALS - KEEP FROZEN” or “TEMPERATURE SENSITIVE MATERIAL - KEEP REFRIGERATED.”

6. *How should I document a specimen’s condition during processing?*

Condition reporting of most cryogenic materials is not performed in the traditional manner. Be sure to report any adverse conditions. For example, document samples that have experienced thawing, freezer-burn, and potentially compromised data.

7. *What health and safety concerns should I be aware of during processing?*

If the cryogenic materials are more consistent to traditional collections (where whole identifiable organisms are maintained), you may be able to use a traditional natural history condition report, as previously noted. Health and safety concerns during processing are primarily associated with human pathogens. However, there also are concerns associated with storage in liquid nitrogen. To prevent injury, be sure to:

- Wear long, insulated gloves to protect the hands and arms against the cold.
- Wear a face shield when accessing material that may have been in the liquid phase of liquid nitrogen.
- Protect all skin against contact with dry ice.

Other hazards that you should be aware of include:

Dry Ice

Do not use dry ice in well-sealed rigid containers. Sublimation of the dry ice can increase internal pressure to the point that the container may explode. Use vented containers only.

Don’t store containers of dry ice in enclosed areas. As dry ice “melts,” carbon dioxide is released. Within enclosed areas, carbon dioxide can build to levels dangerous to people.

Freeze-Dried Specimens

Anyone handling specimens that are being freeze-dried must wear both respiratory protection and gloves for safety. If freeze-dryers are sterilized using ethylene oxide, the staff members who apply the chemical must have special training. They also may be required to have a general license or certification for application of a pesticide and a special license or certification for application of a fumigant. Additional requirements include:

- medical monitoring of personnel
 - environmental monitoring for residual ethylene oxide levels
 - full compliance with all applicable OSHA regulations
-

C. Storage of Low-temperature Collections

1. *Are there any special storage considerations concerning low-temperature collections?*

If there are biological toxins or pathogens involved, you **MUST** possess specialized training, permits, and sufficient security to ensure that the holdings cannot become a danger to public health.

For detailed information concerning the security of collections, see Chapter 9, "Museum Collections Security and Fire Protection."

2. *How should I organize low-temperature collections?*

Organize the collection to enable rapid retrieval and replacement of specimens. Don't let access risk temperature control for other specimens or samples. Place specimens that are frequently used within easy reach. There are two primary methods of organizing cryogenic materials. Both have advantages and disadvantages. Your choice should depend on how your collection is used.

Sequential or chronological organization groups material from a common time and source. Every sample has a definite and predictable location in the storage unit. If a sample has been consumed through prior research, an empty space is left.

- The advantage to this type of organization is the maximization of space.
- The disadvantage is that some research is based on multiple samples of common taxa. This would require the researcher to go through the entire cryogenic collection to obtain the needed samples.

Identification and classification systems organization is another method of arrangement. This involves maintaining samples in groups based on various identification and classification systems.

- The primary advantage is that most material needed for research purposes will be located in one area of the collection. This is less disruptive to the collection as whole.

- The disadvantages are:
 - As new material is added to specific taxa, more space within expensive storage units is required to accommodate expansion
 - The location of individual samples is less definite and predictable than the sequential or chronological organization.

Remember that organization can vary among disciplines and institutions. It may be more practical to simply arrange specimens according to catalog number. Whichever method you choose, be sure that every specimen has a designated and predictable location.

After you have organized your collection, don't forget cabinet signage, labels, and floor plans. Label each low-temperature storage unit with a sign indicating the beginning and ending taxa and catalog numbers. This avoids unnecessary opening of the unit. Use the same method for individual shelves, trays, or other equipment used to hold samples or specimen vials.

The ultimate goal is to allow rapid and easy access to a specimen with minimal handling of other specimen containers.

3. *What are the primary agents of deterioration that affect specimens in storage?*

The agents of deterioration that pose the greatest risks to low-temperature collections in storage are:

- **Neglect**, such as:
 - the improper use of storage equipment
 - failure to monitor environmental conditions
 - careless handling of specimens
 - lack of familiarity with collection organization and arrangement systems
 - disassociation of specimens from data
- **Inappropriate Temperature**, especially:
 - temperature increases
 - repeated exposure to freezing and warming temperatures

Such circumstances will cause specimens to deteriorate.

PRIORITY 1	PRIORITY 2	PRIORITY 3
Neglect	Contaminants	Inappropriate RH

Inappropriate T	Water	Light
	Physical Forces	Pests
	Criminal activity	Fire

Table T.11. Agents of deterioration related to low-temperature storage of specimens.

4. *What special features should I include in low-temperature storage areas?*

Refer to the storage requirements listed in Chapter 7: Museum Collection Storage. To reduce biohazards and chemical hazards, and protect the collections from malfunctioning equipment, you also should:

- Segregate the storage of low-temperature collections from other collection storage operations.
- Provide separate air-handling systems for low-temperature collection storage areas. This will:
 - permit cold rooms and rooms that house mechanical freezers to be cooled on a year-round basis
 - allow special ventilation designs for rooms housing liquid nitrogen tanks
- Provide appropriate security measures.
 - Install key code or other electronic entry control devices for storage rooms.
 - If electronic security is not possible, use a highly restricted key system for entry.
 - Consider adding a security window to the door to permit inspection of the room from the exterior.
 - Activate lighting from outside the room. This will facilitate inspections.
- Equip storerooms with water-based, automatic fire suppression systems and provide for regular inspection, testing, and maintenance of the systems.
- Filter all incoming and recirculated air to the American Society of Heating, Refrigerating and Air-Conditioning Engineers (ASHRAE) 90-95% level.

5. *What types of supplies and equipment are used for storage of low-temperature collections?*

Containers. Containers for specimens must be:

- clean (and in some cases sterile)
- able to withstand the temperatures used for low-temperature storage
- non-reactive towards the specimens and any cryoprotectant fluids

- sealed well enough to prohibit ingress of contaminants or release of material from the specimens
- impermeable to oxygen

Glass or polypropylene containers are usually used for many cryogenic or other low-temperature storage methods. Be aware that:

- Polypropylene is rapidly becoming the most popular type of container material.
- Only some polypropylene or glass vials can be used in the liquid phase of liquid nitrogen. Most must be kept in the nitrogen vapor over the liquid to avoid the potential for rupture unless they are further sealed in polyethylene tubing.
- Some polypropylene vial and closure systems have been designed especially for use in tanks containing liquid nitrogen. These are the best choice for shipping samples collected in the field.

Container closures. The closures for containers vary with the temperature at which the container will be stored. There are some vial and cap systems that are designed to withstand liquid nitrogen temperatures, but it's important to carefully consult the manufacturer's recommendations when choosing a system. **Do not use rubber-stoppered vials for storage at liquid nitrogen temperatures.**

Rack and Trays. A good technique for storing specimens inside mechanical freezers is to use stainless steel racks to hold divided cardboard or polypropylene trays containing the sample vials.

- This allows you to easily label the freezer contents and reduces the number of samples exposed to ambient air during retrieval and replacement.
- There are stainless steel racks suitable for use in either upright or chest freezers.
- Stainless steel racks for use with divided polypropylene trays and aluminum canes have also been developed to hold specimen vials for storage in the vapor over liquid nitrogen. These systems permit retrieval of selected vials without exposing large numbers of specimens to temperature changes.
- You can also use divided tray systems for freeze-dried specimens stored in sealed vials in cold storage rooms or in refrigerators capable of maintaining 2-8°C/35.6-46.4°F or less.

Cold Rooms used to store freeze-dried material are maintained at temperatures just above freezing (2-8°C/35.6-46.4°F).

- Cold Rooms require dehumidification of incoming air to ensure that there is not a problem with condensation that could lead to mold growth.

- They require backup power supplies to ensure that the temperatures are maintained in the event of a power failure.
- Cold Rooms will prolong the shelf life of viable specimens that are preserved by freeze-drying, **but do not guarantee long-term preservation**. You may need to periodically grow new colonies and create new specimens to ensure that stocks are maintained.

Mechanical Freezers (standard freezers and ultracold freezers) are also used to store low-temperature collections.

- Freezers can meet virtually any temperature requirement, **but initial costs and operating costs increase as the desired temperature goes down**.
- Many institutions maintain tissue samples in mechanical freezers at -80°C/-112°F.
 - Long-term preservation that would be achieved at true cryogenic temperatures is sacrificed to economics.
 - Most institutions can afford to maintain temperatures of -80°C/-112°F but cannot afford the cost of lower temperatures.

6. *What else should I know about mechanical freezers?*

Freezers use a lot of energy to obtain temperatures of -80°C/-112°F. They also produce a great deal of heat. Because of this, **only use freezers in rooms that have constant (24 hours/day, year-round) air conditioning or appropriate heat exhaust systems**. You also need to equip the freezers with back-up generators in case of a power failure.

There are two main kinds of mechanical freezers:

- **Upright freezers** are easy for staff to use. However, there is a tendency for temperature gradients to form when the door is opened. This can compromise temperature control.
- **Chest freezers** are less prone to the problem of temperature gradients forming. As noted above, both types become increasingly expensive to purchase and operate as the target temperature drops.

Liquid nitrogen freezers provide an excellent storage medium. They can maintain specimens at temperatures below -130°C/-202°F (usually at least -150°C/-238°F).

- Rooms that contain liquid nitrogen freezers must be properly ventilated:
 - when the freezers are refilled with liquid nitrogen
 - when oxygen levels in the room become too low for human safety
- If a number of liquid nitrogen freezers are housed in the same room, it's best to deliver the nitrogen through pipes from a bulk tank. Don't try to refill the freezers manually.
- Piping for liquid nitrogen has special design requirements, including:
 - insulation

- safety valves

- Use low-pressure tanks to supply the liquid nitrogen. High-pressure tanks can be hazardous to staff during manual refilling. They also can damage the automatic supply units.
- Within the tanks, specimens are usually stored in the vapor over the liquid, but can be stored in the liquid itself.

7. *How should I store specimens inside a freezer?*

Use stainless steel racks to hold divided cardboard or polypropylene trays containing the sample vials. This is a good technique, which:

- allows you to easily label the freezer contents
- reduces the number of samples exposed to ambient air during retrieval and replacement

Stainless steel racks are available for use in either upright or chest freezers.

To hold specimen vials for storage in the vapor over liquid nitrogen, you can use specialized:

- stainless steel racks and divided polypropylene trays
- aluminum canes

These systems permit retrieval of selected vials without exposing large numbers of specimens to temperature changes.

You can also use divided tray systems for freeze-dried specimens stored in sealed vials in cold storage rooms or in refrigerators capable of maintaining 2-8°C/35.6-46.4°F or less.

8. *What about storage of DNA samples?*

Low-temperature storage is not a prerequisite for successful extraction of DNA from specimens. In some cases, it is possible that simply freeze-drying some organ tissues, and then maintaining them in dry conditions might work as well as storing fresh samples at very low temperatures.

The main reason for low-temperature storage for samples preserved for nucleic acids analyses seems to be the ease of extraction when specimens have not been treated by any other methods, rather than the quality of preservation.

DNA can now be removed from highly degraded materials using the polymerase chain reaction (PCR) technique. This method allows DNA to be successfully extracted from increasingly smaller samples of old museum materials. This practice has improved steadily as a result of interest by forensic scientists. As a result, sample size and environmental conditions are not as important as they were when the techniques for DNA extraction were initially developed.

As long as biological tissues have not been contaminated in some adverse fashion, or chemically treated in a way that destroys the nucleic acids, most dry biological specimens can be used for DNA analyses.

9. *Are there any special health and safety concerns related to storage of low-temperature collections?*

The primary health and safety concerns include:

- protection against biohazards
- exposure to high concentrations of carbon dioxide from dry ice
- skin lacerations from exploding ampoules or vials
- injuries resulting from exposure to very low temperatures
- displacement of oxygen caused by evaporation of liquid nitrogen in confined spaces

Consult your regional curator, an industrial hygienist, the Centers for Disease Control and Prevention (CDC), and the National Research Council of the National Academy of Sciences for information concerning the control of specific biohazards. Use face shields and long, insulated gloves when retrieving or replacing samples from the liquid phase of liquid nitrogen. Use long, insulated gloves when working with material in the vapor phase over liquid nitrogen. To protect against low oxygen environments when dealing with liquid nitrogen, equip all storage areas with oxygen monitors, and audible and visible alarms that alert staff to problems before they enter.

D. Maintenance of Low-temperature Collections

1. *Are there any special maintenance issues concerning storage of low-temperature collections?*

Low-Temperature Equipment

Specific maintenance concerns depend on the type of low-temperature equipment that you use. Be sure to discuss these issues with the equipment manufacturer and/or distributor.

Alarm systems are vital! Alarm systems that can warn of power or equipment failures at any time of the day or night are an important part of emergency preparedness for collections preserved at low temperatures. Many “freezer alarms” are designed to be audible or visible only to someone who is nearby when the alarm is triggered. Such alarms are useless 16 hours every weekday and on weekends. Install alarm systems that are monitored 24 hours a day by a UL-listed central station that will immediately notify staff in the event of a power or equipment failure.

Be sure that your park has emergency generators, backup freezers, and/or transportation and storage arrangements in place to move collections in the event of an emergency. This information should be included in your park’s Emergency Operations Plan. Make sure that all staff are aware of these procedures and their individual responsibilities.

Staff Training

Be sure that **all** collection staff have been properly trained. The most common problem with the maintenance of low-temperature collections is

lack of training. Without proper training, uninformed “good intentions” easily can cause specimen damage. For example, tissue samples and other frozen material may deteriorate if:

- freezers are left open
- specimens are transported from freezers to work areas without temperature protection
- specimens are used at room temperature
- you allow repeated cycles of freezing and warming, which will:
 - cause physical damage to the specimens
 - destroy the viability of cell suspensions when their cryoprotective fluids are allowed to warm to room temperature and then are re-frozen
- mishandled, causing:
 - breakage of vials or ampoules
 - contamination by contact with non-sterile surfaces

Any of these instances can destroy the utility of the material. For this reason, full documentation is required for every sample that has been compromised.

Don't underestimate staff training needs, equipment needs, and operational costs for low-temperature storage. All of these requirements can be quite expensive. As with all other types of museum collections, if you cannot provide an appropriate level of care for them, you shouldn't attempt to maintain low-temperature collections at your park. Such collections would be better housed at an institution that specializes in research and care of such collections.

2. *What is involved in salvage of low-temperature collections?*

Salvaging specimens after an emergency or a disaster:

- is usually concerned with stabilizing the specimens
- normally occurs within the first 48-hours after the collection or area is secured from the situation

This initial stabilization may involve some treatments. However, such treatments are not designed for restoration or repair, but to keep further damage at bay. **The primary concern for salvage of low-temperature collections is maintaining the proper preservation temperatures.**

Once most collections preserved at -80°C/-112°F or lower have been defrosted and allowed to remain at room temperatures for more than a few hours, they can be damaged by bacteriological and enzymatic processes. Tissue samples are especially susceptible to this type of damage. Freeze-

dried materials may last much longer if kept in well-sealed containers and not exposed to moisture.

3. *What is the "best method" of salvage?*

Preplanning

As with all potential disasters and emergencies, preplanning is vital. An appropriate and effective emergency and salvage plan can spell the difference between an inconvenience and a major disaster. Be sure that your park's Emergency Operations Plan (EOP) includes relevant information concerning low-temperature collections if your park maintains such materials, **especially information related to any biohazards.**

- Ensure that all staff:
 - are aware of their emergency responsibilities
 - possess appropriate training
 - have full knowledge of all potential hazards (including biohazards)
 - possess proper personal protective equipment
- Conduct periodic reviews of the potential for biohazards for all low-temperature collections.
- Ensure that you implement adequate control measures for any type of emergency situation involving biohazards.
- To prevent release of hazardous organisms during salvage efforts, request assistance from the Centers for Disease Control and Prevention (CDC) and your state health department.
 - **Don't wait until an emergency to contact these organizations and agencies; by then it could be too late.**
 - Include the CDC and your state health department in emergency pre-planning efforts.
 - Be sure that your park's EOP contains all such relevant information.

Emergency Response

HUMAN SAFETY IS PARAMOUNT! Address all potential life safety issues before you attempt any collection salvage. Ensure that:

- All staff possess full knowledge of potential biohazards.
- Facilities are properly ventilated.
- All staff possess appropriate training and personal protective equipment (PPE).
- The park has procedures for the proper disposal of any biohazards, if portions of some samples are not salvageable.

Once it is safe to enter the area, you can start the salvage operation:

- Transfer frozen specimens to backup freezers or to temporary storage in containers with dry ice or liquid nitrogen. Store the specimen over the liquid, not in it, if possible.
- It may be possible to salvage some tissue samples by freeze-drying. This requires that you maintain sterile conditions throughout the freeze-drying process.

Notes:

- If samples from the same voucher specimens are available at other repositories, heroic salvage efforts may not be worthwhile.
- To be effective, all salvage operations should be targeted toward specimens whose importance has been determined in advance. These must be well marked and placed in storage so as to facilitate salvage activities.

IMPORTANT: Be sure that your museum standard operating procedures include information pertaining to the proper disposal of any biohazards, if portions of some samples are not returned to storage after salvage or research use.

4. *Where can I get salvage advice and assistance?*

Contact your regional/SO curator, the Senior Curator of Natural History, a natural history conservator, or staff from a nearby large natural history museum or university repository. You can also contact organizations such as:

The American Type Culture Collection
 PO Box 1549
 Manassas, Virginia 20108
 (703) 365-2700
www.atcc.org

The American Type Culture Collection's staff have specialized expertise in dealing with collections preserved at low temperatures. It's a good idea to include this organization on your park's emergency salvage call list.

5. *How should I document emergency salvage efforts?*

Tissue samples are unlikely to survive for more than a few years at the storage temperatures commonly used for their preservation. As a result, management and care issues tend to overlap for documentation, as with emergency salvage. The primary concerns for collections care documentation are:

- How long has the specimen been in storage?
- How often and under what circumstances has the specimen been used?

Tracking this information will provide a reasonable schedule for disposal of specimens that have outlived their utility and therefore are no longer worth the costs of preservation.

During emergency salvage it is acceptable to simply document all

immediate salvage steps, both in writing and in some type of imaging system. Record specific damage to particularly valuable specimens and specimens from other institutions, and note specific salvage methods that are used. Such data may be important for insurance purposes or essential in resolving liability issues.

SECTION VI: BIOLOGICAL MICROSCOPY COLLECTIONS

A. Overview

1. *Why are some specimens preserved as microscope preparations?*

Scientists preserve certain specimens as microscope preparations to preserve whole or partial organisms for:

- various kinds of microscopic examination
- some kinds of biochemical analyses, including extraction of DNA

Specimens prepared for microscopy may be found in all biological collections, but are most common in these collections:

- entomology
- mycology
- palynology
- parasitology

It's also common for microscopy collections to be ancillary to more traditional collections. Examples of such ancillary collections include:

- histology
- karyology
- hair samples
- scales
- some genitalia

Be sure that microscope slides of parts tied to another specimen are given the same catalog number as the specimen. Link or otherwise cross-reference all data too.

2. *How are specimens preserved as microscope preparations?*

There are several basic types of microscope preparations for biological specimens or specimen parts:

- mounted on flat, glass microscope slides of various sizes, usually with round, square, or oblong cover slips
- in micromounts (paperboard, aluminum, or glass slides that have one or more cavities for the specimen(s), usually with a polyester film or glass cover slip on one side or possibly on both sides
- mounted on stubs for scanning electron microscopy (SEM)
- removed from SEM stubs

- prepared as thin sections (cut into very thin slices) for subsequent examination under various levels of magnification

They can also include casts or other replicas of specimens or specimen parts (often used for SEM).

The specimens or specimen parts for microscopy may be:

- immersed in a natural or synthetic liquid or resinous mounting medium, often with a ringing medium (a material used around the margin of the cover slip to protect the specimen and the mounting medium)
- embedded in a solid or semi-solid wax or resin (often used for thin sections)
- dry-mounted without a mounting medium or coating, but often attached to the slide or stub with a small amount of an adhesive
- coated with various metallic (e.g., aluminum, gold, gold-palladium alloy) or non-metallic substances (such as carbon) to improve the image of the specimen/specimen part for SEM, and attached to a stub with a small amount of adhesive

Specimens prepared for microscope slides or for thin sections are often:

- **cleared** (treated with enzymes or alkaline chemicals that render parts of the specimen transparent to light)
- **stained** (treated with dyes that differentially color various tissues to make them easily visible)

3. *What agents of deterioration affect microscopy collections?*

The impact of various agents of deterioration on microscopy collections is largely unknown. This topic has not yet been adequately examined in scientific studies. As a result, what little that is known comes from observations by collections staff. As with other biological collections, inappropriate temperature, contaminants, neglect, and inappropriate relative humidity levels undoubtedly pose risks to specimens preserved for microscopy. Be aware of the following risks:

Physical Forces

- Glass breakage: specimens mounted on glass substrates are prone to damage from breakage of the glass.
- Specimens mounted on scanning electron microscope stubs are small and usually very fragile.
- Gravity can damage many specimens in mounting media. This is because the media can flow over time and move specimens out from under protective cover slips.

Inappropriate Temperature

The precise temperatures that pose risks vary with the particular medium.

- The mounting, ringing, and sometimes the embedding media used in preparing specimens for microscopy can flow under the force of gravity at room temperatures.
- Elevated temperatures can increase the tendency for mounting media to flow.
- Temperatures at or below freezing may cause the mounting media to fracture.

Contaminants

In general, any gas phase material that can promote the oxidation of an organic substance is likely to cause damage to the synthetic and natural resins used in many mounting and ringing media. This includes peroxides emitted by wood and wood by-products, including many poor quality paper products.

Particulates may also damage specimens prepared for microscopy. This is because they can become absorbed into the surface of some resins, and obscure fine details in the specimens.

Inappropriate Relative Humidity

- Inappropriate relative humidity levels, whether very high or very low are thought to damage some ringing and mounting media.
- It is possible that very high relative humidity could cause some resins to become cloudy or moldy. This would obscure the specimen.
- Very low relative humidity might cause desiccation of mounting, ringing or embedding media. This can lead to physical damage to specimens.

Neglect

Neglect can result in damage to all collections, including microscopy preparations, and is characterized by:

- insufficient knowledge and skills
- failure to follow standards and/or provide adequate documentation
- apathy
- lack of adequate administrative support and funding

Common instances of neglect in microscopy collections include the failure to: link specimen parts to identifiable voucher specimens; provide backup systems to ensure appropriate environmental conditions; provide adequate storage to protect against contaminants.

Visible and UV Light

Microscopy preparations are generally kept in cabinets or boxes that protect them from light. However, during examination, they are apt to be exposed to very intense light. Prolonged exposure will fade the color in some stains. Light sources rich in ultraviolet radiation will not only increase this rate of fading, but may also promote the oxidation (aging, usually accompanied by yellowing) of many media used for embedding, mounting, or ringing.

Pests

Other than insects attracted to the adhesive on paper slide labels, insect and rodent pests are rarely, if ever, a threat to microscopy preparations.

Water

Prolonged immersion in water from a flood or leak will soften some natural and synthetic resins used as various media. Immersion might soften the adhesives used to mount specimens on SEM stubs. It also may damage the ink, paper, or adhesives used in labeling slides, resulting in loss of essential data.

Fire

Fire can cause slides to break, soften media, and may deposit soot on slides and specimens mounted on SEM stubs.

4. *Are there any health and safety concerns related to microscopy collections?*

Yes. Be aware of the following safety issues:

- Any risk from human pathogens that may be present in the specimens is usually greatly reduced if the specimens are mounted in some type of medium.
- The greatest human safety risk is the preparation of the media, due to the toxic nature of some of the chemicals used.
- Once the specimens have been prepared, the risks in subsequent handling of microscope preparations should be minimal. Even so, **always wear nitrile gloves when handling these preparations.**
- Any effort to remount slides or to remove the coatings from SEM specimens can pose significant risks.

There are hundreds of different chemicals and chemical mixtures that have been used in creating microscope preparations in the biological sciences. Some of these include:

- polychlorinated biphenyls (PCBs)
- cyanide solutions (used to remove SEM coatings)
- naphthalene resins or polymers mixed with toluene or other solvents
- organic stains and dyes, many of which are toxic
- chloral hydrate, the common component of most formulations of Hoyer's mounting media, and also an ingredient in many other

mounting media

- phenol
- thymol
- phenolic resins
- Eurparal, a commercial product containing paraldehyde
- cellulose nitrate (flammable)
- formaldehyde
- inorganic and organic acids
- natural plant resin (Canada balsam), which while not a threat in itself, is often thinned with phenol alcohol or xylene
- epoxy resins
- polystyrene resins
- phthalate plasticizers
- metal salts

Refer any interventive treatment of microscope preparations to a conservator or to a specialist in the preparation of the organisms. To ensure human safety and preservation of the specimen, be sure to acquire information on the preparation methods used for any specimens prepared for microscopy.

Of particular concern are:

- the use of toxic chemicals during preparation work
- the impact of toxic chemicals during subsequent handling of the specimens

Be sure to use appropriate engineering controls and personal protective equipment when examining microscope preparations.

B. Stabilization and Processing of Microscopy Collections

IMPORTANT NOTE: For purposes of these guidelines, it is assumed that the conditions of biological specimens and specimen parts intended for a microscopy collection will be under the control of research designs and material utilization. Therefore, the stabilization stage of

microscopy preservation is not a topic of this appendix and should not be part of the responsibility of the collection staff of the park.

Because of the risks to health and safety, as well as the expense of specialized equipment, no individual should be involved with stabilization for microscopy collections without first receiving specialized training that far surpasses any instructions and information provided herein.

1. *What are the primary agents of deterioration that affect microscopy collections?*

For most microscope preparations, there is a great risk of physical damage during processing. This results from direct damage to the specimen during preparation or by damage to the slide, stub, or other support for the specimen during subsequent use. Insufficient knowledge and skills (neglect) can render a specimen useless.

Priority 1	Priority 2	Priority 3
Neglect	Contaminants	Criminal Activity
Physical Forces	Fire	Pests
Inappropriate T°	Water	
Light/radiation		
Inappropriate RH		

Table T.12. Impact of agents of deterioration during processing of microscopy specimens.

2. *How should I handle specimens during processing?*

In addition to following the basic rules for handling collections (listed in Chapter 6), you also should be sure to:

- Keep material in environments that are as close as possible to those used for long-term storage.
- Carefully clean microscope slides of any immersion oils (oils used to enhance viewing when the slides are examined at high magnification) after use.

3. *How should I label microscope slides?*

Paper labels are often used on microscope slides. However, the choice of adhesives for these labels has caused many problems. You can purchase foil-backed, alkaline-buffered paper labels with a neutral acrylic adhesive

from conservation suppliers. You can either cut them to fit the slides or other microscope mounts, or order them pre-cut to specifications.

Note: It's a good idea to also use a diamond-tipped scribe to mark the specimen number on glass slides in case the paper label is lost for any reason.

4. *What types of specimen containers should I use for microscopy preparations?*

The primary specimen container for microscopy preparations is usually a microscope slide, SEM stub, or a micromount. Glass slides, SEM stubs, and the new generation of micromounts made from good quality paper and polyethylene terephthalate film (Mylar D[®] or Melinex 516[®]) are excellent.

You can purchase various boxes that are available from archival and scientific supply firms to store slides, SEM stubs, and micromounts.

Use These Containers:	Don't Use These Containers:
<ul style="list-style-type: none"> • molded polypropylene • polyethylene • metal with powder coatings or uncoated aluminum 	<ul style="list-style-type: none"> • wooden boxes • boxes of poor quality paper products • boxes with interiors of cork, acidic paper boards, and various plastics, such as polyvinyl chlorides (PVC) or polyurethane foam • unstable plastic containers (such as pill boxes or gel containers) • polystyrene (can only be used to house specimens that will not be used for biochemical analysis).

Table T.13. Recommended Storage for Microscopy Collections

5. *How should I pack and ship microscopy specimens for loans?*

Refer to the general packing and shipping guidelines listed in Chapter 6, "Handling, Packing, and Shipping Museum Objects." Be sure to also:

- Cushion specimens in their primary boxes to ensure that there is no movement of the slides, stubs, or micromounts during transport.
- Provide an appropriately sealed and cushioned container that will maintain a stable relative humidity for the specimens.
- Provide a legible and accurate mailing address.
- Provide appropriate invoices and shipping documentation, (including hazardous materials warning and endangered species documentation, where pertinent) to avoid unnecessary opening of the container.
- Provide instructions on how to properly open the container and remove the specimens.
- Provide instructions about the type of preservation to be used for the specimen.
- Comply with all laws and regulations regarding the shipment of

endangered species or hazardous materials.

6. *How should I document a specimen's condition during processing?*

For condition reports for microscope preparations, be sure to include information about the support as well as the specimen. For example, be sure to note:

- chipped, cracked, or broken slides or cover slips (slides with these conditions should not be shipped on loans until the specimens can be remounted properly)
- “infingering” of air into mounting media (usually evidenced by bubbles or voids in the media that extend from the edge of the cover slip inwards)
- flow of mounting media (usually indicated by a less-than-centered position of the specimen)
- cloudiness, discoloration, or crazing of mounting media
- voids or cracks in ringing media
- torn or distorted specimens
- faded stains or dyes
- discolored specimens
- dirt or debris on slides, stubs, or specimens
- mold

C. Storage of Microscopy Collections

1. *How should I organize the collection?*

The most important organization concern is to be sure that the arrangement allows access to selected specimens without jeopardizing other specimens. Organization may vary among disciplines and institutions. In most instances, the organization will be first by nature of preservation (slide or SEM stub), then by taxonomic group, and then catalog number, or simply by catalog number. This type of organization ensures that every specimen has a more-or-less designated and predictable location.

Once the collection is organized, be sure to:

- post adequate informational signage and floor plans throughout the area
- label all storage units with beginning & ending taxa and catalog numbers
- label each slide box or SEM stub box with beginning and ending catalog numbers

Ease of access to a specimen with minimal handling of other specimen containers is the ultimate goal.

2. *What are the primary agents of deterioration for microscopy collections in storage?*

The agents of deterioration that pose the greatest risks in storage of microscope preparations are:

- **Neglect** may be evident through the improper use of storage equipment, careless handling, lack of familiarity with organization and arrangement systems, or disassociation of specimen and data.
- **Temperature increases** may cause some mounting media to flow, damaging specimens in the process. Exposure to freezing temperatures may damage some mounting, ringing, and embedding media.
- **Inappropriate relative humidity (high)** can promote mold growth on some specimens, labels, and some media .
- **Low relative humidity** may promote embrittlement of some media, which can subsequently cause damage to specimens.

Priority 1	Priority 2	Priority 3
Neglect	Contaminants	Criminal Activity
Physical Forces	Fire	Pests
Inappropriate Temperature	Water	Light/UV radiation
Inappropriate RH		

Table T.14. Relationship of the agents of deterioration to the storage of microscope preparations.

3. *What are the appropriate environmental conditions for storage of microscopy collections?*

The optimum conditions for storage of microscope preparations have never been defined. However, reasonable conditions for long-term storage are:

- moderate temperatures, probably in the range of 16.6-22.2°C/62-72°F
- moderate relative humidity, probably in the range of 40-50%

4. *What types of storage equipment should I use?*

Store microscopy collections inside closed storage cabinets. Make sure that the cabinets are properly designed and used.

- All slides must be properly supported and positioned horizontally.
- The stubs should remain upright for SEM preparations.
- Microscope slides and micromounts should be stored flat. See Figure T.2., below.
- Slides stored vertically will allow some mounting media to flow

toward the edge of the cover slip. This often results in damage to the specimens.

- Similar harm can occur if specimens in micromounts are stored vertically. This allows the specimens to rest against the edge of a well or cavity, rather than in the center.

The Best Option:

Acquire steel storage cabinets designed to hold boxes of slides in the proper position so that the slides themselves are horizontal. These cabinets are available with smooth roller-bearing drawers that minimize shock and vibration and are the best available option for most microscopy preparations.

Another Option:

You also can use standard museum storage cabinets to house boxes of slides or micromounts in a horizontal position. If you use this option, be sure that the slides are positioned horizontal to the shelves and that the shelves are cushioned with polyethylene foam (such as Volara[®] Type A).

Figure T.2. Microscope slides stored horizontally in a slide cabinet. Photograph courtesy of the Entomology Research Museum, University of California, Riverside.

5. *Are there any common problems with microscopy collections?*

Yes. They include:

- deteriorating mounting, ringing, or embedding media
- researchers, who may:
 - wish to have an SEM coating removed from a specimen
 - leave a coating of immersion oils on a microscope slide
- a lack of training among staff and/or researchers

6. *What should I do if specimens need to be cleaned, remounted, or treated?*

Aside from gently wiping off immersion oil residues, leave any other cleaning of specimens prepared for microscopy to experts. The removal of SEM coatings can involve the use of extremely dangerous chemicals and is generally not recommended for any biological specimens.

Always refer to an experienced conservator concerning remounting specimens that exhibit deteriorating mounting or ringing media. Most of the common mounting, ringing, and embedding media in collections are not stable. They were chosen for their ability to enhance microscopic examinations, not for longevity. As a result, it is not unusual to see many thousands of deteriorating preparations in a single collection.

Some unpublished studies have been conducted, especially in parasitology collections, to replace deteriorating mounting media. Although there are some successes with certain mounting media, this remains a topic requiring additional research.

7. *What should I know about salvaging microscopy collections?*

Unfortunately, there are no data on the salvage of microscope preparations following disasters. Because most emergencies will result in water damage and subsequent high humidity, the most useful steps probably will involve achieving control over the environment, such as:

- exhausting moisture-laden air from the storage room and replacing it with conditioned (drier) air using specialized dehumidification equipment and fans (leaving specimens in containers and inside closed cabinets)
- air-drying, by removing specimens from containers and cabinets to an area with good ventilation and dehumidification
- arranging to transfer the collection to an environmentally controlled location for examination and possible treatment by experts

8. *Are there any health and safety issues that I should consider?*

As noted above, during any cleaning or remounting process, anyone handling specimens prepared for microscopy can be exposed repeatedly to small quantities of highly toxic materials. When working with such chemicals be sure that:

- all staff have received appropriate training
- all staff possess a full knowledge of the potential chemical hazards
- proper engineering controls are in place

- all staff have appropriate personal protective equipment
- all hazardous waste is properly disposed of

Remember: Human safety is paramount. Address all human safety issues prior to attempting collection salvage. Do not put staff at risk during emergency salvage efforts.

SECTION VII: GLOSSARY

<i>Autolysis:</i>	deterioration of a specimen's cells or tissues due to enzymatic digestion
<i>Denaturant:</i>	chemicals added to ethanol to make it unsuitable for human consumption
<i>Ectoparasites:</i>	a parasite that lives on the exterior of its "host" organism; examples include ticks, lice, and fleas
<i>Exsiccati:</i>	dried fungi specimens that have been identified and labeled
<i>Fixation:</i>	applying a substance that chemically bonds to a specimen to impede deterioration of the specimen by enzymatic digestion
<i>Karyotypes:</i>	a photograph or "map" of a cell's chromosomes
<i>Larvae:</i>	young of any insects that undergo a complete metamorphosis in the course of development into adults
<i>Lipid:</i>	organic fats, oils, and waxes contained in all life forms, which serve as cellular building blocks and provide energy
<i>Lyophilization:</i>	the process of freeze-drying a specimen
<i>Maintenance:</i>	preservation activities associated with corrective actions in response to a real or perceived problem
<i>Periostracum:</i>	the hard outer covering of a mollusk's shell
<i>Processing:</i>	preservation activities beyond stabilization that are related to making the specimen available for use
<i>Pupae:</i>	the metamorphic stage of an insect's life between larvae and adult
<i>Stabilization:</i>	preservation activities associated with halting active deterioration and minimizing the risk of loss, damage, or disorder as it relates to the specimen and its associated information
<i>Storage:</i>	preservation activities associated with housing of the specimens for the sake of access, organization, and protection
<i>Type Specimen:</i>	the specimen used to describe a new species for the first time; type specimens have extremely high scientific value; they are managed as NPS controlled museum property and must be afforded appropriate storage and security
<i>Ultrastructure:</i>	a detailed, complete view of a cell or tissue; visible only through electron microscopy

SECTION VIII: REFERENCES

**A. References for Section
I: The Nature Of
Biological Collections**

Baker, R. "Some Thoughts on Conservation, Biodiversity, Museums, Molecular Characters, Systematics, and Basic Research." *Journal of Mammalogy* 75, no. 2 (1994): 277-287.

**B. References for Section
II: Preservation of
Biological Collections in
General**

ASIS Standing Committee on Museum, Library and Archive Security. *Suggested Guidelines in Museum Security*. Rev. ed. Alexandria: ASIS International, 1997. Available on the web at: <www.stevекeller.com/steve/pdf_files/SecurityStandards/GuidelinesRev97.pdf>.

Baker, R. "Some Thoughts on Conservation, Biodiversity, Museums, Molecular Characters, Systematics, and Basic Research." *Journal of Mammalogy* 75, no. 2 (1994): 277-287.

Ball, C. and A. Yardley-Jones. *Help! A Survivor's Guide to Emergency Preparedness*. Museum Excellence Series: Book 3. Edmonton: Museum Alberta, 2003.

Canadian Conservation Institute. *Publications and Special Products Catalog*. Ottawa: Canadian Conservation Institute, 2003. Available at: <<http://www.cci-icc.gc.ca>>.

Cato, P. *Guidelines for Managing Bird Collections*. Museology No. 7. Lubbock: Texas Tech University Press, 1986.

Cato, P. and C. Jones (eds.). *Natural History Museums: Directions for Growth*. Lubbock: Texas Tech University Press, 1991.

Cato, P., R. Waller, L. Sharp, J. Simmons, S. Williams. *Developing Staff Resources for Managing Collections*. Martinsville, Va.: Virginia Museum of Natural History and Canadian Museum of Nature, 1996.

Childs, J., J. Mills, and G. Glass. "Rodent-Borne Hemorrhagic Fever Viruses: A Special Risk for Mammalogists?" *Journal of Mammalogy* 76, no. 3 (1995): 664-680.

Cohen, D. and R. Cressey (eds.). *Natural History Collections: Past, Present, and Future*. Special issue of the *Proceedings of the Biological Society of Washington*, Volume 82, pp. 559-762. Washington, D.C.: Biological Society of Washington, 1969.

Cosgrove, J., D. Donaldson, G. Hughes, and W. Maloff. "Plague at the Museum: Disease Transmission Potential and Biosafety Precautions." *Collection Forum* 8, no. 1 (1992): 1-8.

Down, J., M. MacDonald, J. Tétreault, and S. Williams. "Adhesive Testing at the Canadian Conservation Institute—An Evaluation of Selected Poly(vinyl acetate) and Acrylic Adhesives." *Studies in Conservation* 41 (1996): 19-44.

Duckworth, D., H. Genoways, and C. Rose. *Preserving Natural Science Collections: Chronicle of our Environmental Heritage*. Washington, D.C.: National Institute for the Conservation of Cultural Property, 1993.

Feller, R. and M. Wilt. *Evaluation of Cellulose Ethers for Conservation*. Research in Conservation 3. Los Angeles: Getty Conservation Institute, 1990.

Floray, S. "Safer Cleaning Alternatives for the Museum and Visitor Center." *Conserve O Gram* 2/21. Washington, D.C.: National Park Service, 2003.

- Gage, K., R. Ostfeld, and J. Olson. "Nonviral Vector-Borne Zoonoses Associated with Mammals in the United States." *Journal of Mammalogy* 76, no. 3 (1995): 695-715.
- Garrett, K. "Documentation Guidelines for the Preparation of Biological Specimens." *Collection Forum* 5, no. 2 (1989): 47-51.
- Genoways, H., C. Jones, and O. Rossolimo (eds.). *Mammal Collection Management*. Lubbock: Texas Tech University Press, 1987.
- Gorton, P., F. Schieppati, and M. Conquino. *Health and Safety for Archaeologists and CRM Professionals*. Buffalo: Panamerican Environmental, Inc. and Panamerican Consultants, Inc., 1999.
- Hawks, C. "An Introduction to Respirator Use in Collections Management." *Conserve O Gram* 2/13. Washington, D.C.: National Park Service, 2000.
- Hawks, C., and K. Makos. "Inherent and Acquired Hazards in Museum Objects: Implications for Care and Use of Collections." *CRM* 23, no. 5 (2000): 31-37.
- Heyer, W., M. Donnelly, R. MacDiarmid, L-A Hayek, and M. Foster (eds.). *Measuring and Monitoring Biological Diversity: Standard Methods for Amphibians*. Washington, D.C.: Smithsonian Institution Press, 1994.
- Hoagland, K. (ed.). *Guidelines for Institutional Policies and Planning in Natural History Collections*. Washington, D.C.: Association of Systematics Collections, 1994.
- Irvin, A., J. Cooper, and S. Hedges. "Possible Health Hazards Associated with the Collection and Handling of Post-Mortem Zoological Material." *Mammal Review* 2, no. 2 (1972): 43-54.
- Krebs, J., M. Wilson, and J. Childs. "Rabies—Epidemiology, Prevention, and Future Research." *Journal of Mammalogy* 76, no. 3 (1995): 681-694.
- Layne, S. *The Cultural Property Protection Manual*. Denver: Layne Consultants International, 2002.
- McLaren, S., P. August, L. Carraway, P. Cato, W. Gannon, M. Lawrence, N. Slade, P. Sudman, R. Thorington, S. Williams, and S. Woodward. *Documentation Standards for Automatic Data Processing in Mammalogy: Version 2.0*. American Society of Mammalogists, Committee on Information Retrieval, 1996.
- McLaren, S. and J. Braun (eds.). *GIS Applications in Mammalogy*. Norman: Oklahoma Museum of Natural History and The Carnegie Museum of Natural History, 1993.
- Merritt, E. "Conditions on Outgoing Research Loans." *Collection Forum* 8, no. 2 (1992): 78-82.
- Metzger, D. and S. Byers. *Managing the Modern Herbarium: An Interdisciplinary Approach*. Washington, D.C.: Society for the Preservation of Natural History Collections and The Royal Ontario Museum, Centre for Biodiversity and Conservation Biology, 1999.
- Michalski, S, M. MacDonald, T. Strang, J. Tétreault, and R. Williams. 1992. *A Systematic Approach to the Conservation (Care) of Museum Collections, with Technical Appendices*. Ottawa: Canadian Conservation Institute.
- Miller, E. (ed.). *Museum Collections: Their Roles and Future in Biological Research*. Occasional Papers Series No. 25. Victoria: British Columbia Provincial Museum, 1985.
- Mills, J., T. Yates, J. Childs, R. Parmenter, T. Ksiazek, P. Rollin, and C. Peters. "Guidelines For Working With Rodents Potentially Infected with Hantavirus." *Journal of Mammalogy*, 76, no 3 (1995): 716-722.
- Monk, R. *Bar Code Use in the Mammal Collection at the Museum of Texas Tech University*. Museology 8. Lubbock: Texas Tech University Press, 1998.

- National Park Service. *Conserve O Gram* series. Washington, D.C.: National Park Service. Available at <http://www.cr.nps.gov/museum/publications/consveogram/conserv.html> ≥.
- Nudds, J. and C. Pettitt (eds.). *The Value and Valuation of Natural Science Collections*. Proceedings of the International Conference, Manchester, 1995. London: The Geological Society, 1997.
- Rose, C., C. Hawks, and H. Genoways (eds.). *Storage of Natural History Collections: A Preventive Conservation Approach*. Washington, D.C.: Society for the Preservation of Natural History Collections, 1995.
- Rose, C., and A. R. de Torres (eds.). *Storage of Natural History Collections: Ideas and Practical Solutions*. Washington, D.C.: Society for the Preservation of Natural History Collections, 1992.
- Rose, C., S. Williams, and J. Gisbert. (eds.). *Current Issues, Initiatives, and Future Directions for the Preservation and Conservation of Natural History Collections*. Vol. 3 in Proceedings of the International Symposium and First World Congress on the Preservation and Conservation of Natural History Collections, Madrid, 10-15 May 1992. Madrid: Consejería de Educación y Cultura, Comunidad de Madrid, y Dirección General de Bellas Artes y Archivos, Ministerior de Cultura, 1993.
- Simmons, J. *Herpetological Collecting and Collections Management*. Rev. ed. Herpetological Circular No. 31. Society for the Study of Amphibians and Reptiles, 2002.
- Society for the Preservation of Natural History Collections. "Guidelines for the Care of Natural History Collections." *Collection Forum* 10, no. 1 (1994): 32-40.
- Stansfield, G., J. Mathias, and G. Reid. *Manual of Natural History Curatorship*. London: HMSO, 1994.
- Waddington, J. and D. Rudkin (eds.). *Proceedings of the 1985 Workshop on the Care and Maintenance of Natural History Collections*. Life Sciences Miscellaneous Publications. Toronto: Royal Ontario Museum, 1986.
- Williams, S. *Destructive Preservation: A Review of the Effect of Standard Preservation Practices on the Future Use of Natural History Collections*. Göteborg Studies in Conservation 6. Göteborg, Sweden: Acta Universitatis Gothoburgensis, 1999.
- Williams, S. and L. Brandstetter-Wolansky. "Examination of Macroscopic Particles from Dust Accumulations in Collection Storage Areas." *Collection Forum* 18, nos. 1-2 (2003): 90-97.
- Williams, S. and P. Cato. "Interaction of Research, Management, and Conservation for Serving the Long-Term Interests of Natural History Collections." *Collection Forum* 11, no. 1 (1995): 16-27.
- Williams, S. and C. Hawks. "Inks for Documentation in Vertebrate Research Collections." *Curator* 29, no. 2 (1986): 93-08.
- Wilson, D., F. Cole, J. Nichols, R. Rudran, and M. Foster (eds.). *Measuring and Monitoring Biological Diversity: Standard Methods for Mammals*. Washington, D.C.: Smithsonian Institution Press, 1996.
- Wood, R. and S. Williams. "An Evaluation of Disposable Pens for Permanent Museum Records." *Curator* 36, no. 3 (1993): 189-200.

**C. References for Section
III: Dry Biological
Collections**

- Agnew, N. "The Corrosion of Egg Shells by Acetic Acid Vapour." *ICCM Bulletin* 7, no. 4 (1981): 3-9.
- Baskin, B. "Solar Bagging: Putting Sunlight to Work to Eliminate Insect Infestations in Mere Hours." *WAAC (Western Area for Art Conservation) Newsletter* 23, no. 1 (2001): 20-22.

- Briggs, D, P. Sell, M. Block and R. I'Ons. "Mercury Vapour: A Health Hazard in Herbaria." *New Phytologist*, 94 (1983): 453-457.
- Burke, J. "Anoxic Microenvironments: A Treatment for Pest Control." *Conserve O Gram* 3/9. Washington, D.C.: National Park Service, 1999.
- Cato, P. *Guidelines for Managing Bird Collections*. Museology No. 7. Lubbock: Texas Tech University Press, 1986.
- Child, R. (ed.). *Conservation and the Herbarium*. Leigh, Worcestershire, U.K.: Institute of Paper Conservation, 1994.
- _____. "Monitoring Insect Pests with Sticky Traps." *Conserve O Gram* 3/7. Washington, D.C.: National Park Service, 1998.
- Espinoza, E. and M-J. Mann. *Identification Guide for Ivory and Ivory Substitutes*. 2d rev ed. Washington, DC: World Wildlife Fund, 1991.
- Florian, M-L. "The Effects of Freezing and Freeze-Drying on Natural History Specimens." *Collection Forum* 6, no. 2 (1990): 45-52.
- Hawks, C. and S. Williams. "Care of Specimen Labels in Vertebrate Research Collections." In *Proceeding of the 1985 Workshop on Care and Maintenance of Natural History Collections*, edited by J. Waddington and D. Rudkin, 105-108. Life Sciences Miscellaneous Publications. Toronto: Royal Ontario Museum, 1986.
- Hawks, C., S. Williams, and J. Gardner. *The Care of Tanned Skins in Recent Mammal Collections*. Museology No. 6. Lubbock: Texas Tech University Press, 1974.
- Hawks, C. and D. Von Endt. "Mercury and Mercury Compounds in Natural History Collections: An Annotated Bibliography." *Natural History Conservation* 5 (1990): 4-19.
- Health Canada, Pest Management Regulatory Agency. *Effective Control of Rats and Mice*. Ottawa: Health Canada, Pest Management Regulatory Agency, 2001. On the web at: <http://www.pmr-arla.gc.ca/english/consum/ratsandmice-e.html#5>.
- Horie, C. "Fading of Feathers by Light." Pp. 431-435 in *Preprints of the ICOM Committee for Conservation 9th Triennial Meeting, Dresden, Germany, 26-31 August 1990*. Paris: ICOM Committee for Conservation.
- Kigawa, R., H. Nochide, H. Kimura, and S. Miura. "Effects of Various Fumigants, Thermal Methods, and Carbon Dioxide Treatment on DNA Extraction and Amplification: A Case Study on Freeze-Dried Mushroom and Freeze-Dried Muscle Specimens." *Collection Forum* 18, nos. 1-2 (2003): 74-89.
- Linnie, M. "Use of a Low-Oxygen Atmosphere for the Control of Insect Pests." *Collection Forum* 14, no. 1 (2000): 57-65.
- Metzger, D. and S. Byers. *Managing the Modern Herbarium: An Interdisciplinary Approach*. Washington, D.C.: Society for the Preservation of Natural History Collections and The Royal Ontario Museum, Centre for Biodiversity and Conservation Biology, 1999.
- Monk, R. *Bar Code Use in the Mammal Collection at the Museum of Texas Tech University*. Museology 8. Lubbock: Texas Tech University Press, 1998.
- Peigler, R. "Shipping of Pinned Insects." *Collection Forum* 8, no. 2 (1992): 73-77.
- Pinniger, D. "Controlling Insect Pests: Alternatives to Pesticides." *Conserve O Gram* 3/8. Washington, D.C.: National Park Service, 1998.
- Poole, M. "Preliminary Analysis of the Effects of Cold Storage on Fur Garments and Mammal Skins." *Collection Forum* 13, no. 1 (1997): 25-39.

- Purewal, V. "An Investigation into the Composition of Botanical Wax Models with a View to Their Conservation." *Collection Forum* 13, no. 1 (1997): 11-19.
- Purewal, V. "The Identification of Hazardous Pesticide and Fungicide Residues on Herbarium Material." *SSCR Journal* 10, no. 4 (1999): 5-9.
- Raphael, Toby. "An Insect Pest Control Procedure: The Freezing Process." *Conserve O Gram* 3/6. Washington, D.C.: National Park Service, 1994.
- Rogers, S., M. Schmidt, and T. Gütebier. *An Annotated Bibliography on Preparation, Taxidermy and Collection Management of Vertebrates with Emphasis on Birds*. Special Publication No. 15. Pittsburgh: Carnegie Museum of Natural History, 1989.
- Rose, C., C. Hawks, and H. Genoways (eds.). *Storage of Natural History Collections: A Preventive Conservation Approach*. Washington, D.C.: Society for the Preservation of Natural History Collections, 1995.
- Rose, C. L., and A. R. de Torres (eds.). *Storage of Natural History Collections: Ideas and Practical Solutions*. Washington, D.C.: Society for the Preservation of Natural History Collections, 1992.
- Shchepanek, M. "Observations of Temperature and Relative Humidity During the Cooling and Warming of Botanical Specimens for Insect Pest Control." *Collection Forum* 12, no. 1 (1996): 1-7.
- Simmons, J. *Herpetological Collecting and Collections Management*. Rev. ed. Herpetological Circular No. 31. Society for the Study of Amphibians and Reptiles, 2002.
- Strang, T. "A Review of Published Temperatures for the Control of Pest Insects in Museums." *Collection Forum* 8, no. 2 (1992): 41-67.
- _____. "Detecting Infestations: Facility Inspection Procedure and Checklist." *CCI Notes* 3/2. Ottawa: Canadian Conservation Institute, 1996.
- _____. "Controlling Insect Pests with Low temperature." *CCI Notes* 3/3. Ottawa: Canadian Conservation Institute, 1997.
- _____. "The Effect of Thermal Methods of Pest Control on Museum Collections." In *Biodeterioration of Cultural Property* 3. Edited by C. Aranyanak and C. Shinghasiri, 334-353. Proceedings of the 3rd International Conference on Biodeterioration of Cultural Property, 4-7 July 1995, Bangkok, Thailand. Bangkok: Thammasat University Press.
- Tennent, N. and T. Baird. "The Deterioration of Mollusca Collections: Identification of Shell Efflorescence." *Studies in Conservation* 30 (1985): 73-85.
- Waddington, J. and J. Fenn. "Preventive Conservation of Amber: Some Preliminary Investigations." *Collection Forum* 4, no. 2 (1988): 25-31.
- Williams, S. "Investigation of the Causes of Structural Damage to Teeth in Natural History Collections." *Collection Forum* 7, no. 1 (1991): 13-25.
- Williams, S. and C. Hawks. "Arsenic in Natural History Collections." *Leather Conservation News* 2, no. 2 (1986): 1-4.
- _____. "Inks for Documentation in Vertebrate Research Collections." *Curator* 29, no. 2 (1986): 93-08.
- _____. "History of Preparation Materials Used for Recent Mammal Specimens. In *Mammal Collection Management*, edited by H. Genoways, C. Jones, and O. Rossolimo, 21-48. Lubbock: Texas Tech University Press, 1987.
- _____. "Deterioration of Bone and Ivory: An Annotated Bibliography." *Natural History Conservation* 5 (1990): 25-27.

- Williams, S. L., R. Laubach, and H. H. Genoways. 1977. *A Guide to the Management of Recent Mammal Collections*. Special Publication 4. Carnegie Museum of Natural History, Pittsburgh. 105 pp.
- Williams, S. and S. McLaren. "Modification of Storage Design to Mitigate Insect Problems." *Collection Forum* 6, no. 1 (1990): 27-32.
- Williams, R., J. Waddington, and J. Fenn. "Infrared Spectroscopic Analysis of Central and South American Amber Exposed to Air Pollutants, Biocides, Light, and Moisture." *Collection Forum* 6, no. 2 (1990): 65-75.
- Wood, R. and S. Williams. "An Evaluation of Disposable Pens for Permanent Museum Records." *Curator* 36, no. 3 (1993): 189-200.
- Yu, D. S. Klein, and D Reindl. "An Evaluation of Silica Gel for Humidity Control in Display Cases." *WAAC (Western Area for Art Conservation) Newsletter* 23, no 1 (2001): 14-19.
- Zyberman, L. and J. Schrock (eds.). *A Guide to Museum Pest Control*. Washington, D.C.: Foundation of the American Institute for Conservation and the Association of Systematics Collections, 1988.

**D. References for Section
IV: Wet Biological
Collections**

- Andrei, M. and H. Genoways. "Changes in pH in Museum Storage Fluids, I—Effects of Resistal Paper Labels." *Collection Forum* 12, no. 2 (1991): 63-75.
- Bayer, J. and T. Counihan. "Length Changes in White Sturgeon Larvae Preserved in Ethanol or Formaldehyde." *Collection Forum* 15, nos. 1-2 (2001): 57-64.
- Billy, A. "The Effects of Formalin and Isopropyl Alcohol on Length and Weight Measurements of *Sarotherodon mossambicus* Trewavas." *Journal of Fish Biology* 21 (1982): 107-112.
- Boase, N. and R. Waller. "The Effect of Propylene Glycol on Ethanol Concentrations Determined by Density Measurement." *Collection Forum* 10, no 2 (1994): 41-49.
- Camacho, A. and J. Bedoya. "Evaluation of the Effects of Different Preservative and Fixative Fluids on Aquatic Invertebrates from Interstitial Waters." *Collection Forum* 10, no. 1 (1994): 20-31.
- Carter, J. "An Investigation of pH Changes in a Selection of Formaldehyde Buffering Agents Used on a Fish Parasitology Research Collection." *Collection Forum* 13, no 1 (1997): 1-10.
- Clark, P. "Ground Glass Stoppered Jars for Fluid Collections." In *Storage of Natural History Collections: Ideas and Practical Solutions*, edited by C. Rose and A. de Torres, 221-223. Washington, D.C.: Society for the Preservation of Natural History Collections, 1992.
- Clark, P., O. Crimmen, F. Naggs, A. Wahl, and M. Mansfield. "Transportation of Fluid-Preserved Natural History Specimens Stored in Glass Containers: New Solutions to an Old Problem." *Collection Forum* 10, no. 1 (1994): 1-9.
- Fery, J., T. Yates, D. Duszynski, W. Gannon, and S. Gardner. "Designation and Curatorial Management of Type Host Specimens for New Parasite Species." *Journal of Parasitology* 78, no. 5 (1992): 930-932.
- Gisbert, J. and R. Garcia-Perea. "Double-jar system for types in fluid collections." In *Storage of Natural History Collections: Ideas and Practical Solutions*, edited by C. Rose and A. de Torres, 225-226. Washington, D.C.: Society for the Preservation of Natural History Collections, 1992.

- Gisbert, J., F. Palacios, and R. Garcia-Perea. "Labeling Vertebrate Collections with Tyvek® Synthetic Paper." *Collection Forum* 6, no. 1 (1990): 35-37.
- Lohrer, F. "Magnetic Label Holders for Metal Storage Equipment – System No. 1. and System No. 2." In *Storage of Natural History Collections: Ideas and Practical Solutions*, edited by C. Rose and A. de Torres, 261-264. Washington, D.C.: Society for the Preservation of Natural History Collections, 1992.
- Hochberg, E. "Colored Dots for Coding Fluid Collections." In *Storage of Natural History Collections: Ideas and Practical Solutions*, edited by C. Rose and A. de Torres, 267-268. Washington, D.C.: Society for the Preservation of Natural History Collections, 1992.
- Hughes, G. and J. Cosgrove. "pH Change in a Formalin Borax Solution with Inferences about Uses of Neutralized Formalin in Vertebrate Collections." *Collection Forum* 6, no. 1 (1990): 21-26.
- McCoy, C. "Packing Fluid-Preserved Herpetological Specimens for Shipment." *Collection Forum* 9, no. 2 (1993): 70-75.
- Ratcliffe, B. and C. Messenger. "Vial Support System for Fluid Collections." In *Storage of Natural History Collections: Ideas and Practical Solutions*, edited by C. Rose and A. de Torres, 21-214. Washington, D.C.: Society for the Preservation of Natural History Collections, 1992.
- Scott, N. and A. Aquino-Shuster. "The Effects of Freezing on Formalin Preservation of Specimens of Frogs and Snakes." *Collection Forum* 5, no. 2 (1989): 41-46.
- Sendall, K. and G. Hughes. "Correcting Alcohol Concentrations." *SPNHC Newsletter* 11, no. 1 (1997): 6-7.
- Simmons, J. *Herpetological Collecting and Collections Management*. Herpetological Circular No. 16. Tyler, Texas: Society for the Study of Amphibians and Reptiles, 1987.
- _____. "Storage in Fluid Preservatives." In *Storage of Natural History Collections: Ideas and Practical Solutions*, edited by C. Rose and A. de Torres, 161-186. Washington, D.C.: Society for the Preservation of Natural History Collections, 1992.
- _____. "Vial Supports for Cleared and Stained Specimens." In *Storage of Natural History Collections: Ideas and Practical Solutions*, edited by C. Rose and A. de Torres, 215-216. Washington, D.C.: Society for the Preservation of Natural History Collections, 1992.
- _____. *Herpetological Collecting and Collections Management*. Herpetological Circulars No. 31. Rev. ed. Marceline, MO: Society for the Study of Amphibians and Reptiles, 2002.
- Snyder, A. (comp.). *Proceedings of the 1992 ASIH Workshop on Collections Care and Management Issues in Herpetology and Ichthyology*. American Society of Ichthyologists and Herpetologists, 1993.
- Snyder, A. (comp.). 1994. *Proceedings of the 1993 ASIH Workshop on Collections Care and Management Issues in Herpetology and Ichthyology*. American Society of Ichthyologists and Herpetologists. 51 pp. [2] + 20 pp.
- Steedman, H. (ed.). *Zooplankton Preservation and Fixation*. Monographs on Oceanographic Methodology 4. Paris: The UNESCO Press, 1976.
- Steigerwald, M. and S. Laframboise. "Tape Applications: A Jar Sealing Method for Reducing Ethanol Evaporation in Fluid-Preserved Collections." *Collection Forum* 12, no. 2 (1996): 45-54.
- Stoddard, D. "Fixatives and Preservatives: Their Effects on Tissue." In *Conservation of Natural History Specimens: Spirit Collections*, 1-25. Manchester: Manchester Museum and Department of Environmental Biology, University of Manchester, 1989.
- Stuart, J. "Observations on Formalin-Induced Darkening of Herpetological Specimens." *Collection Forum* 11, no. 2 (1995): 39-45.

- Suzumoto, A. "Storage Containers for Fluid-Preserved Specimens." In *Storage of Natural History Collections: Ideas and Practical Solutions*, edited by C. Rose and A. de Torres, 217-220. Washington, D.C.: Society for the Preservation of Natural History Collections, 1992.
- van Dam, A. "DMDN-Hydantoin: The Promising Result of a Search for an Alternative in Fluid Preservation of Biological Specimens." *Collection Forum* 18, nos. 1-2 (2003): 104-115.
- _____. "The Interactions of Preservative Fluid, Specimen Container, and Sealant in a Fluid Collection." *Collection Forum* 14, no 1 (2000): 78-92.
- Von Endt, D. "Spirit Collections: A Preliminary Analysis of Some Organic Materials Found in the Storage Fluid of Mammals." *Collection Forum* 10, no. 1 (1994): 10-19.
- Von Endt, D., E Yourd, and P. Hare. "Spirit Collections: Accelerated Aging Studies Concerning the Stability of Keratin in Ethanol and Formalin." *Collection Forum* 14, no. 1 (2000): 66-77.
- Waller, R. and D. McAllister. "A Spot Test for Distinguishing Formalin from Alcohol Solutions." In *Proceedings of the 1985 Workshop on the Care and Maintenance of Natural History Collections*, edited by J. Waddington and D. Rudkin, 93-99. Life Sciences Miscellaneous Publications. Toronto: Royal Ontario Museum, 1986.
- Waller, R. and J. Simmons. "An Exploratory Assessment of the State of a Fluid-Preserved Herpetological Collection." *Collection Forum* 18, nos. 1-2 (2003): 1-37.
- Waller, R. and T. Strang. "Physical Chemical Properties of Preservative Solutions—I. Ethanol-Water Solutions." *Collection Forum* 12, no. 2 (1996): 70-85.

**E. References for Section
V: Biological Low-
Temperature Collections**

- American Society for Testing and Materials. *Standard Practice for Preservation by Freezing, Freeze-Drying, and Low-temperature Maintenance of Bacteria, Fungi, Protista, Viruses, Genetic Elements, and Animal and Plant Tissues*. Guide E1342-97. Philadelphia: American Society for Testing and Materials, 1997.
- _____. *Standard Guide for Handling Hazardous Biological Materials in Liquid Nitrogen*. Guide E1556-00. Philadelphia: American Society for Testing and Materials, 2000.
- Baker, R. "Some Thoughts on Conservation, Biodiversity, Museums, Molecular Characters, Systematics, and Basic Research." *Journal of Mammalogy* 75, no. 2 (1994): 277-287.
- Baker, R. and M. Hafner. "Curation of Collections of Frozen Tissues: Curatorial Problems Unique to Frozen Tissue Collections." In *Collections of Frozen Tissues: Value, Management, Field and Laboratory Procedures, and Directory of Existing Collections*, edited by H. Dessauer and M. Hafner, 35-40. Lawrence: Association of Systematics Collections, 1984.
- Baker, R. and M. Haiduk. "Collections of Tissue Cultured Cell Lines Suspended by Freezing." *Acta Zoologica Fennica* 170: 91-92.
- Cato, P. "Racks and Dividers to Organize Small Frozen Samples." In *Storage of Natural History Collections: Ideas and Practical Solutions*, edited by C. Rose and A. de Torres, 201-202. Washington, D.C.: Society for the Preservation of Natural History Collections, 1992.
- Cato, P. and D. Schmidly. "Policies concerning the use and management of ancillary preparations in vertebrate systematic collections." In *Natural History Museums: Directions for Growth*, edited by P. Cato and C. Jones, 91-104. Lubbock: Texas Tech University Press, 1991.

- Cosgrove, J. 1992. "Tub and Divider System for Fluid Collections." In *Storage of Natural History Collections: Ideas and Practical Solutions*, edited by C. Rose and A. de Torres, 205-206. Washington, D.C.: Society for the Preservation of Natural History Collections, 1992.
- Dessauer, H. and M Hafner (eds.). *Collections of Frozen Tissues: Value, Management, Field and Laboratory Procedures, and Directory of Existing Collections*. Lawrence, Ks.: Association of Systematics Collections.
- Gareis, P., C. Cowley, and H. Gallisdorfer. "Operating Characteristics of Biological Storage Vessels Maintained with Liquid Nitrogen." *Cryobiology* 6, no. 1 (1969): 45-56.
- Hawksworth, D., I. Sastramihardja, R. Kokke, and R. Stevenson. *Guidelines for the Establishment and Operation of Collections of Cultures and Microorganisms*. World Federation for Culture Collections, 1990.
- Malik, K. (ed.). *Technical Information for Culture Collections Curators in Developing Countries*. Paris: UNESCO and World Federation of Culture Collections-Education Committee, 1992.
- Merryman, H. *Cryobiology*. London: Academic Press, 1966.
- Monk, R. *Bar Code Use in the Mammal Collection at the Museum of Texas Tech University*. *Museology* 8. Lubbock: Texas Tech University Press, 1998.
- National Research Council Committee on Hazardous Biological Substances in the Laboratory. *Biosafety in the Laboratory: Prudent Practices for Handling and Disposal of Infectious Materials*. Washington, D.C.: National Academy of Sciences, 1989.
- Richmond, J., and R. McKinney (eds.). *Biosafety in Microbiological and Biomedical Laboratories*. 4th rev. ed. U.S. Department of Health and Human Services, Public Health Service, Centers for Disease Control and Prevention, and National Institutes of Health, 1999. Available on the web at: <<http://www.cdc.gov/od/ohs/biosfty/biosfty.htm>>.
- Simione, F. "Storage of Living Cells in Culture." In *Storage of Natural History Collections: Ideas and Practical Solutions*, edited by C. Rose and A. de Torres, 273-274. Washington, D.C.: Society for the Preservation of Natural History Collections, 1992.
- _____. "Storage in Standards and Ultra-Cold Freezers: Living Biological Specimens." In *Storage of Natural History Collections: A Preventive Conservation Approach*, edited by C. Rose, C. Hawks, and H. Genoways, 157-186. Washington, D.C.: Society for the Preservation of Natural History Collections, 1995.
- Woodward, S. and W. Hlywka. "A Database for Frozen Tissues and Karyotype Slides." *Collection Forum* 9. no. 2 (1993): 76-83.

**F. References for Section
VI: Biological
Microscopy Collections**

- Brown, P. "A Review of Techniques Used in the Preparation, Curation and Conservation of Microscope Slides at the Natural History Museum, London." *The Biology Curator* Issue 10 Supplement. Biology Curators' Group, 1997.
- Fery, J., T. Yates, D. Duszynski, W. Gannon, and S. Gardner. "Designation and Curatorial Management of Type Host Specimens for New Parasite Species." *Journal of Parasitology* 78, no. 5 (1992): 930-932.
- Garner, R. and C. Horie. "The Conservation and Restoration of Slides of Mosses." *Studies in Conservation* 29 (1984): 93-99.

Golden, J. "Golden Oldies: Curating SEM Specimens." *Collection Forum* 5, no. 1 (1989): 17-26.

_____. "Storage for SEM stubs." In *Storage of Natural History Collections: Ideas and Practical Solutions*, edited by C. Rose and A. de Torres, 271-272. Washington, D.C.: Society for the Preservation of Natural History Collections, 1992.

Goodway, M. "Storage System for Microscopical Preparations." In *Storage of Natural History Collections: Ideas and Practical Solutions*, edited by C. Rose and A. de Torres, 269. Washington, D.C.: Society for the Preservation of Natural History Collections, 1992.

Harris, R. *A Selective Bibliography on Preservation, Macro and Micro-anatomical Techniques in Zoology*. Report No. 3. Biology Curators' Group, 1984.

Pritchard, M. and G. Kruse (comps.). *The Collection and Preservation of Animal Parasites*. Lincoln: University of Nebraska Press, 1982.

Upton, M. "Aqueous Gum-Chloral Slide Mounting Media: An Historical Review." *Bulletin of Entomological Research* 83 (1993): 267-274.

SECTION IX: NON-NPS REPOSITORIES WITH SERVICEWIDE OR MULTI-REGIONAL AGREEMENTS TO HOUSE PARK BIOLOGICAL COLLECTIONS

The National Park Service seeks and maintains long-term agreements with qualified institutions to assist in managing park collections. These umbrella agreements establish terms and conditions under which park collections will be preserved, housed, managed, and accessed, as well as the responsibilities of all parties to the agreement.

The Chief Curator and the Associate Director, Natural Resources negotiate the agreements. Parks that place specimens with a cooperating repository must prepare a loan form documenting all specimens.

The contact information for institutions with Servicewide agreements to curate NPS natural science collections are as follows:

A. Low-Temperature Collections

The American Type Culture Collection
PO Box 1549
Manassas, Virginia 20108
(703) 365-2700
<http://www.atcc.org/SpecialCollection/NPS.cfm>

The American Type Culture Collection (ATCC) makes available for research microorganisms collected in parks. Park collections are on loan to ATCC under the terms of this agreement. Copies of the agreement, which includes related NPS procedures, are available from the Chief Curator at ann_hitchcock@nps.gov.

B. Other Specimens

At this time, the National Park Service has no Servicewide agreements with any non-NPS repositories for curation of NPS botanical, animal, fluid-preserved, or microscopy collections. Several parks, regions, and/or networks have agreements at that level; contact your regional/SO curator for additional information.

Appendix U: Curatorial Care of Paleontological and Geological Collections

Page

Section I: Paleontological Collections	U:1
A. Overview	U:1
What information concerning paleontological collections will I find in this appendix?	U:1
Why is it important to practice preventive conservation with paleontological specimens?	U:1
How do I learn about preventive conservation?	U:1
Where can I find the latest information on care of paleontological specimens?	U:2
B. Paleontological Collections and Fossils	U:2
What are paleontological collections?	U:2
What is a fossil?	U:2
Are there other types of fossils?	U:2
How can I identify the fossils in my collection?	U:3
C. Body Fossils	U:3
How did body fossils develop?	U:3
What is Permineralization?	U:3
What is replacement?	U:4
What is carbonization?	U:4
What are molds and casts?	U:4
What are nodules?	U:4
What is amber?	U:4
D. Trace Fossils	U:4
How did trace fossils form?	U:4
How are trace fossils usually exhibited?	U:4
What else should I know about trace fossils?	U:5
E. Factors that Contribute to Specimen Deterioration	U:5
How can I minimize deterioration of paleontological specimens?	U:5
How can I identify active deterioration of a paleontological specimen in storage?	U:6
How can I stop active deterioration of a specimen once it's started?	U:6
What is pyrite disease?	U:7
How can I protect my specimens from pyrite disease?	U:7
What should I do if I notice pyrite disease?	U:8
What else should I consider when confronting pyrite disease?	U:8
F. Handling and Storage of Paleontological Specimens	U:9
What factors should I consider when accepting paleontological specimens for storage?	U:9
How do I ensure the preservation of specimens in storage?	U:10
What temperature and humidity levels should I maintain in storage?	U:10
Should I be concerned about light levels?	U:10
What about dust?	U:10
What is the proper way to handle paleontological specimens?	U:11
Are there any other handling issues?	U:12
What type of storage equipment should I use?	U:12
How should I label fossil specimens?	U:14

G.	Health and Safety Issues	U:15
	What health and safety issues are related to paleontological specimens?	U:15
	What types of specimens might be radioactive?	U:15
	How do I test fossils for radioactivity?	U:16
	What is radon?	U:16
	How should I protect staff and the public from radioactive specimens?	U:16
	Who should I consult for additional safety information?	U:18
	Are there any special requirements for loans and shipping of radioactive specimens?	U:18
H.	Security and Fire Protection of Paleontological Collections	U:19
	What are the fire and security considerations for paleontological collections?	U:19
	How can I determine if certain specimens are monetarily valuable?	U:20
	Are some specimens at increased risk of theft and/or vandalism?	U:20
	How should I best protect specimens at risk?	U:20
I.	Exhibiting Paleontological Specimens	U:20
	What should I consider when planning or rehabilitating an exhibit?	U:20
	Are there any other exhibit planning considerations?	U:21
	Are there any particular environmental concerns for specimens on exhibit?	U:21
	Where can I obtain additional information about exhibiting paleontological specimens?	U:21
J.	Preparation and Conservation of Specimens	U:22
	What is preparation?	U:22
	Who can I contact to prepare my park's fossil specimens?	U:22
	Why should I contact a preparator?	U:23
	Are there preparators that my park can hire under contract to prepare specimens?	U:24
	Are there any special considerations regarding preparation?	U:24
	How much time does it take to prepare a specimen?	U:25
	Should I have damaged and/or incomplete specimens repaired?	U:25
	Are there occasions when I should not have a preparator repair a damaged specimen?	U:25
	What's the best way to repair specimens?	U:25
	What about applying protective coatings to specimens?	U:26
	Who should clean specimens?	U:26
Section II: Geological Collections		U:27
A.	Overview	U:27
	What information concerning geological collections will I find in this appendix?	U:27
	Why is it important to practice preventive conservation with geological specimens?	U:27
	How do I learn about preventive conservation?	U:27
	Where can I find the latest information on care of geological specimens?	U:27
B.	Geological Collections	U:28
	What types of geological specimens are generally found in park collections?	U:28
	What is a rock?	U:28
	What is a mineral?	U:29
	What are ores?	U:29
	Why do some collections include cave formations?	U:29
	Why do some collections contain quarried stone?	U:30
	How do I identify the different types of specimens?	U:30
C.	Factors That Contribute to Specimen Deterioration	U:30
	What agents of deterioration affect geological specimens?	U:30

How can I identify active deterioration?	U:30
How can I protect my specimens from deterioration?	U:31
What is the best relative humidity and temperature for my specimens?	U:31
Should I be concerned about atmospheric pollution?	U:31
Does cleaning contribute to deterioration?	U:32
Are there any other deterioration concerns?	U:32
D. Handling and Storage of Geological Collections	U:32
What do I need to know about handling specimens?	U:32
How should I store specimens?	U:33
What additional protection do geological specimens need in storage?	U:33
E. Health and Safety Issues	U:34
What health and safety issues are related to geological specimens?	U:34
How can I best protect the health of staff and researchers using potentially toxic collections?	U:35
What other safety concerns should I consider?	U:35
Could some specimens be radioactive?	U:36
What terms should I know that are relative to radioactivity?	U:36
How can I determine if specimens are radioactive?	U:37
What is radon?	U:37
How should I protect staff and the public from radioactive specimens?	U:38
Are there any other human health risks associated with geological specimens?	U:39
F. Security Concerns	U:39
Are some types of specimens at increased risk of theft and/or vandalism?	U:39
How should I best protect specimens at risk?	U:39
G. Exhibiting Geological Specimens	U:40
What should I consider when planning an exhibit?	U:40
Are there any particular concerns for exhibiting geological specimens?	U:40
Are there any specific situations that I should avoid when exhibiting geological specimens?	U:40
What should I know about cleaning geological specimens?	U:40
H. Conservation of Specimens	U:41
When should I contact a conservator?	U:41
Should park staff repair damaged and/or incomplete specimens?	U:41
What types of repairs can a conservator undertake?	U:41
What type of damage is beyond repair by a conservator?	U:42
Should protective coatings be applied to specimens?	U:42
What about cleaning specimens?	U:42
Section III: References	U:43
A. National Park Service Resources	U:43
B. Professional Organizations	U:43
C. Glossary	U:44
D. Web Resources	U:45
E. Bibliography	U:46
List of Figures	
Figure U.1. Cabinet Storage of Paleontological Specimens	U:13
Figure U.2. Paleontological Specimen Cradled in Polyethylene Foam-lined Fiberglass Jacket	U:13
Figure U.3. Radioactive Specimen Cabinet with Venting System and Safety Signage	U:18
Figure U.4. Preparator Preparing a Specimen	U:23

Figure U.5 Example Preparation Record #1.....	U:49
Figure U.6. Example Preparation Record #2.....	U:51

APPENDIX U: CURATORIAL CARE OF PALEONTOLOGICAL AND GEOLOGICAL COLLECTIONS

SECTION I: PALEONTOLOGICAL COLLECTIONS

A. Overview

1. *What information concerning paleontological collections will I find in this appendix?*

This appendix will:

- introduce you to the preventive conservation of paleontological specimens
- provide you with the information necessary for the day-to-day management of your fossil collections
- prepare you to carry out the duties associated with the long-term storage of a paleontological collection
- not teach you the skills of fossil preparation or conservation, as practiced by trained preparators and conservators

The appendix includes:

- a discussion of the characteristics of paleontological collections
- tools to help you recognize deterioration
- information about proper storage environments
- health and safety concerns
- a listing of NPS resources and outside organizations that can provide you with additional information

2. *Why is it important to practice preventive conservation with paleontological specimens?*

Fossils may seem to be “hard as stone.” You might then assume that fossils require little monitoring or preventive conservation. This isn’t the case. Paleontological collections do require an appropriate level of preventive conservation. Without routine monitoring (including good baseline information), the first indication of a problem is usually when a specimen starts to crumble. Often, little can be done at this point. The deterioration is irreversible. This results in:

- damage to the specimen
- the loss of scientific information.

3. *How can I learn about preventive conservation?*

Read about the agents of deterioration in Section E and the proper storage of paleontological specimens in Section F. See Chapter 3: Preservation: Getting Started, and Chapter 4: Museum Collections Environment, for a discussion on the agents of deterioration. For information on exhibits, refer to Museum Handbook, Part III (MH-III), Chapter 7: Using Museum Collections in Exhibits and NPS CD-ROM publication, Exhibit Conservation Guidelines, available from the Harpers Ferry Center (see

Section III. References).

4. *Where can I find the latest information on care of paleontological specimens?*

See Section III. References. This section lists contact information for NPS resources, professional organizations devoted to paleontology and geology, a glossary, Internet resources, and a bibliography.

B. Paleontological Collections and Fossils

1. *What are paleontological collections?*

Paleontology is the study of ancient life. It includes the five kingdoms of life (Monera, Protista, Fungi, Plantae, and Animalia), but most paleontological collections are identified as:

- vertebrates
- invertebrates
- plants

NPS paleontological collections cover the entire span of geological time and represent all five kingdoms of life.

2. *What is a fossil?*

A fossil is any evidence of past life preserved in the earth's crust. Fossils can be divided into two main categories:

- body fossils are the preserved remains of a plant or animal
- trace fossils are indications of past animal activity such as:
 - tracks
 - burrows
 - borings
 - gnaw or bite marks
 - coprolites (fossilized feces)

The study of trace fossils is called ichnology.

3. *Are there other types of fossils?*

Unaltered fossils result from burial conditions that prevent decomposition, such as low temperatures or low humidity. The classic example of an unaltered fossil is a frozen woolly mammoth. Bison and horses also have been found preserved in Alaskan permafrost. In arid environments, mummified specimens may be preserved in caves or in pack rat middens.

Unaltered fossils are extremely sensitive to changing environmental conditions. If you remove such specimens from the field, you must duplicate the field environment within the museum (temperature,

humidity, etc.). This will ensure their continued preservation.

4. *How can I identify the fossils in my collection?*

Because a wide variety of plants and animals have fossilized, it's very difficult for anyone to identify every type of fossil. You can consult a paleontologist, but remember that even the experts can't identify all fossils. Most paleontologists specialize in one (or several) plant or animal group(s), fossils from a specific geologic time, or fossils in a given geographic area.

There are many "popular" guides to fossils, but you'll probably need to consult the scientific literature to confirm a fossil's identification.

C. Body Fossils

1. *How did body fossils develop?*

Body fossils formed when an organism died and was rapidly buried. This minimized decomposition and destruction from scavengers. (These fossils escaped the natural recycling process!)

Common burial sites include rivers and lakes or other areas of rapid sedimentation. The death either occurred there or the specimen was quickly transported to the area shortly after death. After burial, the specimen was protected from further transport, scavenging, and some types of decay. Eventually, minerals from ground water cemented the surrounding sediments. Body fossils were preserved by:

- permineralization
- replacement
- carbonization
- molds and casts
- nodules
- amber

Organisms, particularly vertebrates with a skeleton made of numerous parts often are represented by isolated bones and teeth. Individuals that died at the site of deposition and were quickly buried are more likely to be preserved as complete, well-preserved specimens.

Organisms that were transported are more likely to be incomplete. They also may show signs of transport such as

2. *What is Permineralization?*

Permineralization is what we commonly associate with fossils. "Petrified" or "fossilized" are words used to describe a fossil preserved this way. Minerals have been deposited in the specimen. It has "turned to stone." Even though minerals were deposited in the specimen, it still may retain part of its original organic structure. If you examine the fossil under a microscope at high magnification, you may see the original organic material with minerals deposited in spaces. The logs at Petrified Forest

National Park are a good example of permineralization.

3. *What is replacement?*

Replacement is similar to permineralization, except that none of the original specimen survived. Minerals replaced the original components. The replacement occurred at the molecular level, so all of the original details may be preserved.

4. *What is carbonization?*

Carbonized fossils are often preserved on the bedding planes of shale. These shales were often deposited in water that is low in oxygen. This permitted the preservation of soft-bodied organisms that would not otherwise have been preserved. Heat and pressure of sediments reduced the original plant or animal to a carbon film. Many types of plants and animals that would not normally be preserved in other environments are preserved this way. The best examples are fossil fish from the Green River Formation at Fossil Butte National Monument and the insects and leaves at Florissant Fossil Beds National Monument.

5. *What are molds and casts?*

- A mold formed when the original fossil dissolved. This left a cavity within the surrounding rock. This negative impression preserves the external details of the original specimen. One rare form of mold can form when lava flows around a living tree. Tree molds are found at Craters of the Moon, El Malpais, and Lava Beds National Monuments.
- A cast is formed if this negative impression later filled with sediment. The cast may preserve all of the external morphological details of the original specimen but lacks any microscopic details.
- A steinkern is another type of mold. Steinkerns can result when a shell (such as a snail or clam) filled with sediment and then dissolved. The hardened sediment preserves a reverse image of the formerly hollow inside of the shell.

6. *What are nodules?*

During preservation the original organic material may serve as a nucleus around which minerals are deposited. The minerals may be deposited in layers and eventually the original specimen becomes completely encased in a nodule. Depending on the types of minerals and environment of deposition, the original fossil may be preserved or only an impression may be left. Often the fossil can only be seen when the nodule is cracked open.

7. *What is amber?*

Amber is fossilized resin produced by various trees. Amber results from the evaporation of volatile organic compounds, and oxidation and polymerization. Amber often includes insects or other arthropods and pieces of plants.

D. Trace Fossils

1. *How did trace fossils form?*

Trace fossils result from an animal disturbing sediments (such as burrowing worms, a dinosaur leaving footprints in the mud, or depositing dung). These specimens are usually found in rock.

2. *How are trace fossils usually exhibited?*

Because there are no hard parts to be preserved, trace fossils are generally found as molds, casts, and infillings. They may be difficult to distinguish from the surrounding rock. Larger trace fossils, such as track sites of multiple tracks, are usually left in-situ.

Smaller specimens, such as large pieces of rock containing trace fossils, are sometimes transported to the visitor center for an outdoor display. Such specimens may not have been accessioned and cataloged into the museum collection. If not, you should accession and catalog them. Remember: If such fossils are displayed outdoors, or within reach of visitors, the specimens are subject to consumptive use, including wear, deterioration, vandalism, or environmental damage.

Trace fossils are not expendable. Take proper steps to ensure their long-term preservation. Even tracks displayed in a “structure” that prevents visitors from touching them can suffer deterioration, due to environmental fluctuations (Shelton et al, 1993). Ensure that all paleontological exhibits at your park have addressed preventive conservation issues to the extent possible. For additional information, refer to Section I. “Exhibiting Paleontological Specimen” below, and the National Park Service CD-ROM publication, Exhibit Conservation Guidelines (see Section III. References).

For a more conservation-friendly approach to outdoor exhibits, use reproductions of fossils for visitor center design elements and interpretive dinosaur “track walks.”

3. *What else should I know about trace fossils?*

Trace fossils generally require less preparation than body fossils. Different kinds of trace fossils may require different types of care. For example, caves in the Grand Canyon and the Guadalupe Mountains preserve unaltered dung of the extinct ground sloth. Dung of mammoths and extinct brush-ox are found in alcoves in Glen Canyon. This type of original organic material requires a different preservation approach than slabs of rock with tracks. Such specimens are extremely fragile and break easily; handle them with extreme care.

For storage of dung or other trace fossils of original organic material:

- Store the specimens in cabinets with low humidity.
- Protect the fossils from insect pests.

You may need to build a microclimate within the storage cabinet using desiccants (see Conserve O Gram [COG] 1/8 “Using Silica Gel in Microenvironments”).

E. Factors that Contribute to Specimen Deterioration

1. *How can I minimize deterioration of paleontological specimens?*

Preservation of paleontological collections is a collaborative effort between field paleontologists, laboratory preparators, and curators. Everyone brings a different perspective and expertise to the matter. It’s important to understand the concerns and needs of each professional when making decisions about how to care for the specimens.

Preservation begins in the field. You should:

- Work with the paleontologist who collects the specimen and the preparator who prepares it in the laboratory.
- Address conservation issues throughout the project.
- Ensure that everyone is using current conservation techniques. When in doubt, contact the NPS Geologic Research Division (GRD), Paleontology Program Coordinator or the Senior Curator of Natural History for advice.
- Make any necessary notations to catalog records or other documentation, such as:
 - conservation information from the paleontologist or preparator
 - type of glues and preservatives used to stabilize the fossil, both in the field and in the lab

Note: Be sure to request all preparation data from the preparator. This includes a list of solvents and any other chemicals used on a specimen.

- Follow through with proper curatorial care and museum storage conditions.

2. *How can I identify active deterioration of a paleontological specimen in storage?*

The best way to detect active deterioration is careful, routine observation:

- Note the condition of specimens when they arrive for storage.
- Create a baseline photograph of every specimen upon arrival.
- Are there small bits of unattached bone associated with the specimen, or is the specimen completely intact?
- Is the specimen well supported and padded with an appropriate material such as polyethylene foam?
- Are some delicate parts prone to damage from gravity or mishandling?
- Previously attached bone or rock pieces under/around a specimen are a sign of deterioration and crumbling!

3. *How can I stop active deterioration of a specimen once it's started?*

First, determine the cause of the deterioration:

- Was the specimen mishandled?
- Are the environmental conditions in storage appropriate?
- Did the deterioration occur because of routine cleaning?
- Is the specimen properly supported (such as cavity packing using

polyethylene foam)?

- Is the specimen crumbling due to glue failure or a preservative used during preparation?

You should be able to eliminate some of these causes of deterioration. Others require the skills of an experienced paleontologist. When in doubt, contact the GRD Paleontology Program Coordinator or the Senior Curator of Natural History for advice. Be prepared to discuss:

- the type of paleontological specimen
- what formation it came from
- who collected it
- its present storage environment
- types of preservatives used

The GRD Paleontology Program Coordinator or the Senior Curator of Natural History may suggest that you contact the person who collected or prepared the specimen, or possibly a professional paleontologist who works at another park.

Do not undertake any type of conservation procedure on a specimen unless you are an experienced paleontologist with appropriate training.

4. *What is pyrite disease?*

Pyrite disease is common in some fossil collections. Pyrite disease results from the oxidation of iron pyrite (“fool’s gold”) in a fossil. Pyrite can be present in bone, invertebrate shell, or plant fossils. The oxidation of pyrite will affect microcrystalline or framboidal pyrite far more than it does larger crystals. The resultant iron sulphate (FeSO₄) causes fossils to crumble as the crystals grow and expand. The damage is preventable, but irreversible once it begins.

5. *How can I protect my specimens from pyrite disease?*

Keep the fossils in a stable environment. Temperature and humidity fluctuations promote pyrite “rot.” Consolidants, coatings, or adhesives can be of use only if they are introduced to the specimen under vacuum conditions to coat all surfaces internally and externally. Even carefully conserved specimens can explode spectacularly due to pyrite “rot” building up under the protective skin of preservatives.

The only way to slow the oxidation is to lower the relative humidity. If the reaction has not started, keep RH at 45% or lower; if it has started, reduce it to 30% or lower. It’s possible to clean the reaction products off the surface of a specimen. This requires a very specific procedure and specialized training. Untrained personnel can easily inflict further damage to, or destroy the specimen.

Remember: Prevention is always better than treatment.

6. *What should I do if I*

Follow these steps:

notice pyrite disease?

- Remove the specimen from its storage environment to a work area.
- Brush away and discard the dry powdery reaction product with a dry, soft brush. If you're fortunate, you may need to do nothing more than rehouse the specimen at this point.
- If you can't keep the RH below 45%, and pyrite problems exist, you'll have to upgrade your storage environment. Possible solutions:
 - Build a microclimate within the storage cabinet using desiccants (see COG 1/8 "Using Silica Gel in Microenvironments").
 - Create an anoxic (low- or no-oxygen) environment (see COG 3/9 "Anoxic Microenvironments: A Treatment for Pest Control"). For a collection of known reactive specimens, anoxic film enclosures will help slow the reaction. But be aware that it never stops.
 - For a large collection, consider installing climate-control equipment for an entire case or cases.

7. *What else should I consider when confronting pyrite disease?*

Cross-Contamination

The pyrite oxidation reaction liberates sulfuric acid. This can damage other specimens and storage materials. Do not let other specimens touch infected ones. Also, encapsulate specimen labels (don't laminate them) so that they are not in direct contact with the specimen.

Susceptibility to pyrite disease

A fossil's susceptibility to pyrite disease may depend on the types of rock in which it was preserved. Holmberg (2000) noted a good example of this principle:

Two fossil whale skeletons containing pyrite were obtained from Miocene clay. They were found in different states of preservation, though they had been stored under identical conditions. One of the skeletons was embedded primarily in light-colored clay dominated by the mineral smectite. (Smectite has a high absorption capability and low pH.) The other embedding medium consisted of other clay minerals, mainly kaolinite and illite. (These minerals have a neutral pH resulting from the presence of carbonates, which work as buffers.) Pyrite in the fossil bones from smectite-rich clays was more susceptible to deterioration after exposure than bone containing pyrite preserved in clays dominated by other clay minerals.

F. Handling and Storage of Paleontological Specimens

1. *What factors should I consider when accepting paleontological specimens for storage?*

Specimens collected and prepared by experienced paleontologists should arrive well supported, padded, and stable. The fossils can range in size from less than a millimeter to thousands of pounds. They are stored in many different ways, including:

- attached to the head of a pin inserted into a polyethylene stopper in a vial
- “cavity packed” in their own form-fitted plaster cradle
- in specimen trays of various sizes with polyethylene sheeting used as padding
- small microfossils mounted on special slides that can be stored in a slide cabinet

When accepting collections for storage, be sure to:

- inspect each specimen and make sure each one is well supported and padded
- ask the paleontologist about the materials used for padding:
 - Do they off gas?
 - Are they durable?
 - If the materials used to pad the specimens have loose threads or fibers, such as cotton and cheesecloth, these can easily snag on delicate parts of the fossil. Ask the paleontologist about other options.
- ask the paleontologist to demonstrate how the specimens should be handled.
- see how easily the specimens return to the storage container.
- note if the specimen label can be seen without handling the specimen. If not, discuss other options with the paleontologist.

Remember: Don't accept the specimens if they have not been properly prepared for storage. You can contact the GRD Paleontology Program Coordinator, the Senior Curator of Natural History, or your regional/SO curator for advice.

2. *How do I ensure the preservation of specimens in storage?*

Practice preventive conservation. Be sure to:

- House the specimens in a proper environment. See the CD-Rom publication *Exhibit Conservation Guidelines*, available from the Harpers Ferry Center.
- Use standard geology/paleontology cabinets for most specimens (see *Tools of the Trade* for additional information). As with other collections, you can store small specimens in trays, and cavity-pack them in polyethylene foam.
- For larger specimens, you'll probably need to use open shelf storage.
 - Very large specimens such as sections of petrified logs may require their own pallet for support.
 - To move these specimens, you'll need a pallet jack.
- Protect the collection from dust and excessive light levels.
- Always use proper handling techniques.
- Pad and support each specimen appropriately.
- Use appropriate storage equipment (see *Tools of the Trade*).

Improper storage and handling is a leading cause of specimen deterioration. Fossils are often more fragile than they appear, even if they are mostly rock. Many specimens cannot support their own weight, which makes them extremely vulnerable to improper handling.

3. *What temperature and humidity levels should I maintain in storage?*

For a mixed paleontological collection, keep a stable:

- temperature between 59° and 77° F.
- relative humidity at 45-55%.

4. *Should I be concerned about light levels?*

There is no evidence that light levels (UV or visible) adversely affect fossils. However, they do affect glues and preservatives used to preserve specimens. So be sure to keep light levels as low as possible.

5. *What about dust?*

Airborne dust that settles on specimens is highly abrasive. Cleaning fossils, even with the gentlest techniques, causes damage too. To help eliminate dust in storage areas:

- keep circulating air as clean as possible (use primary and secondary filtering systems whenever possible)
- keep museum cabinet doors closed
- use dust covers on open rack shelving

- practice good housekeeping procedures:
 - consistently carry out all specified duties
 - use appropriate methods as approved by your park's Housekeeping Plan
 - use proper equipment, such as a HEPA vacuum cleaner and a HEPA air purifier (if needed). See Tools of the Trade for information concerning supplies and equipment.

6. *What is the proper way to handle paleontological specimens?*

Contrary to standard museum practice, DO NOT wear cotton gloves when handling paleontological specimens. Fossils may be slippery. You can easily drop a specimen. Use your clean, bare hands to assure a good grip.

Some specimens may have special handling requirements. Discuss these issues with the paleontologist who collected or prepared the specimens. Call the GRD Paleontology Program Coordinator or Senior Curator of Natural History if questions arise. Have enough staff available to assist with especially vulnerable or heavy specimens.

In general, handle specimens as you would other museum objects:

- Handle specimens as infrequently as possible.
- Handle each specimen as though it's irreplaceable and the most specimen valuable in the collection.
- Never smoke, eat, or drink while handling specimens.
- Don't wear anything that may damage the specimen. To avoid scratching and snagging surfaces, be careful of breast pocket contents, jewelry, watches, and belt buckles.
- Use only a pencil when examining specimens.
- Save all information that is associated with the specimen, such as tags and labels.
- Know the condition of a specimen before moving it.
- Lift and/or move the specimen by supporting its strongest structural component. Do not lift it by protruding parts, small bones, or attachments. These areas are weak.
- Use a utility cart with padded shelves and raised sides to transport specimens from one room, area, or building to another. See Tools of the Trade for additional information.
- Handle only one specimen at a time and use both hands. Use one hand for support and the other hand for balance.

- If you need to temporarily place a specimen in an unstable position for examination, be sure to support it. Exercise extreme caution in these situations. Return the specimen to a stable base or surface as soon as possible.
- Never hurry when handling specimens. Move slowly.

If part of a specimen is broken, reattach it as soon as possible to prevent it from becoming separated or lost.

7. *Are there any other handling issues?*

Researchers will need to handle specimens in order to study them. But don't assume that every paleontologist who requests collections access is aware of all the proper handling procedures.

Be sure that you:

- know how to appropriately handle all of the specimens in your collection.
- thoroughly brief all collections users on proper specimen handling techniques. A good way to do this is to provide all researchers with a copy of your park's "Collections Handling Guidelines."
- require all collections users to sign a statement agreeing to abide by these and any other applicable rules, as a condition of access.

For additional information, refer to:

- Chapter 6: Figure 6.14, "Example of Written Handling Rules for NPS Collections" on page 6:30
- Appendix G: Figure G.6., "Sample Visitor Log" on page G:32, and Figure G.7., "Conditions for Access to Museum Collections" on page G:33

8. *What type of storage equipment should I use?*

Paleontological specimens can vary in size from less than a millimeter to thousands of pounds. You may need to use several different types of storage equipment. Options include:

Standard museum cabinets offer an added measure of security and environmental control. Use cabinets for all specimens small enough to fit safely in a drawer. Take care not to overload cabinets or drawers. As with other collections, use cavity packing and padding to keep specimens in place and eliminate any movement when someone opens a drawer. See Figure U.1. below.



Figure U.1. Cabinet storage of paleontological specimens. Individual specimens are cavity-packed in polyethylene foam-lined specimen trays. Courtesy of John Day Fossil Beds National Monument.

Open rack shelving with a steel frame and $\frac{3}{4}$ inch plywood shelves, will safely hold moderate size specimens. Use exterior grade plywood and completely seal all surfaces. You can use either a 2-component water-based epoxy paint or a water-based urethane sealant. Line each shelf with polyethylene foam and pad/support each specimen with foam or another suitable material. Another option is to use custom-made reinforced fiberglass jackets (see Figure U.2. below). This is the same principle as cavity packing, but on a much larger scale.



Figure U.2. Paleontological Specimen cradled in polyethylene foam-lined fiberglass jacket. Courtesy of John Day Fossil Beds National Monument.

Remember: Unsupported components of specimens can easily be damaged by gravity. Also, do not over-pack shelves. This will increase the likelihood of damage from handling.

Pallets are a safe technique to store large specimens. Some fossils may weigh thousands of pounds. Pallets are a relatively inexpensive alternative to specially designed, heavyweight shelves. You'll need a pallet jack, a front-end loader, or a forklift to transport these large specimens. Be sure to properly support all specimens, especially before moving them. You will also need to have room for the forks of a loader to get under the pallet without damaging the specimen or support structure. Discuss methods for moving the specimens with the paleontologist who collected or prepared them. You can also contact the GRD Paleontology Program Coordinator or the Senior Curator of Natural History for assistance.

9. *How should I label fossil specimens?*

Labeling Directly on Specimens

You can directly label bone, shell, and other specimens with a hard, fairly smooth surface. Be sure to use a stable acrylic resin (such as Acryloid B-72) to seal the surface below the number. If you don't, inks can penetrate many surfaces. This can cause permanent alteration or require aggressive scraping to remove labeling errors. See COG 1/4 for additional information.

If the surface is too rough or irregular to permit writing directly on the specimen:

- Place a small square of enamel paint (usually white) on the specimen to provide a surface for the catalog number.
- Make sure the paint is completely dry before writing the catalog number.
- Keep the painted area as small as possible in order not to obscure anatomical details.

Be careful not to write the catalog number in a place that will obscure any critical anatomical details.

Other Labeling Strategies

For other types of fossils (those that lack a hard surface), such as the trace fossils discussed above, you'll have to use different labeling methods. Such techniques are similar to those used for other types of collection materials, and may include:

- paper labels tied to the specimen with string
- catalog numbers written on storage containers (using permanent ink)
- labels attached to storage containers
- labels otherwise attached to the specimens in a non-permanent way, such as:
 - a twill tape label (with the catalog number written on the tape in permanent ink) tied to or gently, but not tightly! tied around the

- specimen
- a similarly-used Tyvek® label

For additional labeling strategies, refer to Appendix T: Curatorial Care of Biological Collections, COG 1/4, your regional/SO curator, the NPS Geologic Research Division (GRD), Paleontology Program Coordinator or the Senior Curator of Natural History.

G. Health and Safety Issues

1. *What health and safety issues are related to paleontological specimens?*

Many fossils are oversized and heavy. Don't injure yourself or others. Always:

- Lift properly (use your legs to avoid back strain). For moving and lifting heavy specimens use a:
 - pallet jack
 - forklift
 - other equipment

Note: Before using any such equipment, be sure that you and others are properly trained in its safe operation.

- Maintain a good grip; don't drop a specimen on someone's foot.
- Wear personal protective equipment (PPE), if needed, such as:
 - Hard hats when working beneath large full skeleton exhibits or whenever you're below overhead hazards that:
 - a) might fall on you
 - b) you might bump your head against.
 - Respirators if a specimen is being prepared. This will protect you from inhaling hazardous mineral dust.

Note: Before you can use a respirator, you must first undergo a medical evaluation, formal training, and fit testing. For additional information concerning respirator use, see COG 2/13.

Be aware that some specimens may be radioactive.

2. *What types of specimens might be radioactive?*

Fossils from any of these deposits may be radioactive:

- The Morrison Formation and the Glens Ferry Formation contain uranium.

- Black Shales can emit radon.
- Phosphate deposits like the Phosphoria Formation may include radon-producing minerals.
- Carnotite, which contains uranium, is often found in fossil logs in the Morrison Formation, present in many western parks.
- Sandstone often contains petrified trees and other fossils, which may be radioactive

Ask the collector if the specimens were checked for radioactivity. If not, you'll need to arrange for testing.

3. *How do I test fossils for radioactivity?*

Use a Geiger Counter or a Scintillator. If you do not have this equipment, perhaps a local university's geology department or the state geologist's office can help.

Another option is this low-cost test:

Place a small piece of unexposed black and white photographic film in a lightproof sleeve and place the specimen on the sleeve. When the film is developed, any fogging will indicate that the specimen is radioactive (Blount, 1990).

4. *What is radon?*

Radon is a radioactive gas resulting from the radioactive decay of radium. Radium is formed by the decay of uranium. As radon decays, it forms radioactive by-products called progeny, decay products, or daughters. These radioactive by-products, if inhaled, can damage lung tissue and cause lung cancer.

Radon is invisible and odorless. It is a dangerous health hazard when it accumulates to high levels inside homes or other structures. Radon is deadly. Indoor radon exposure is estimated to be the second leading cause of lung cancer deaths each year in the United States.

If your park's collection contains radioactive fossils, be sure to monitor radon levels in specimen cabinets and storage areas. Your park safety officer can arrange for appropriate radon

5. *How should I protect staff and the public from radioactive specimens?*

Never be careless around radioactive materials. Follow these general rules:

- Minimize all contact with radioactive specimens.
- Protect everyone from breathing in radon or inhaling or ingesting other radioactive particles.
 - Do not crush, saw, or grind radioactive minerals so as to cause their dust to enter the air, especially indoors.

- As with all museum specimens, never smoke, drink, or eat while handling radioactive minerals.

Note: Inhalation of radon or breathing in or ingesting radioactive minerals or their dust is the most likely method of radiation exposure.

- Wear latex or nitrile gloves whenever handling radioactive specimens.
- Always wash your hands after handling radioactive minerals.
- Work to minimize deposits of radioactive particulates on staff:
 - Always wear a labcoat or other protective outer wear.
- Store all radioactive specimens appropriately. Post proper labels and signage (see Figure U.3. below). Make sure that everyone knows the nature of the materials that they might be handling. Be sure to provide everyone accessing these collections with guidance on handling, precautions, and procedures.
- You may need to store radioactive specimens in a special cabinet with a venting systems (see Figure U.3. below). Refer to Conserve O Gram 2/5 "Fossil Vertebrates as Radon Sources: Health Update" for additional information.
- If possible, store radioactive specimens in a separate, secured room that is vented to the outdoors.

Additional Important Safety Notes:

The general rules stated above are NOT adequate for specimens emitting high levels of radiation. Consult an industrial hygienist or the National Institute for Occupational Safety and Health (NIOSH) for assistance developing appropriate control measures.

Contact NIOSH by telephone at: (800) 356-4674 or on the web at:
< <http://www.cdc.gov/niosh/homepage.html>> .

NIOSH also conducts Health Hazard Evaluations (HHE). A HHE is the study of a workplace to see if workers are exposed to hazardous materials or harmful conditions. To request a HHE, or for more information, see the HHE Program website at: < <http://www.cdc.gov/niosh/hhe/default.html>> . Requests for a HHE must be in writing. The HHE Program website includes an on-line HHE Request Form.

For additional information concerning a HHE relative to paleontological collections, refer to:

Jiggins, Timothy, E., John J. Cardarelli, and Steven H. Arhrenholz. NIOSH Health Hazard Evaluation Report: Hagerman Fossil Beds National Monument, National Park Service, U.S. Department of the Interior, Hagerman, Idaho, HETA 96-0264-2713. Cincinnati:

National Institute for Occupational Safety and Health, 1998.
Available on the web at:
< <http://www.cdc.gov/niosh/hhe/reports/pdfs/1996-0264-2713.pdf>> .

Remember:

- There is an inverse square relationship between the level of exposure to radiation from a mineral and the distance you are from it. Radiation levels drop off dramatically the farther you are from the specimen.
- If you plan to use shielding for a radioactive mineral on exhibit, build it using wood and/or acrylic (Plexiglas®).



Figure U.3. Radioactive Specimen Cabinet with Venting System and Safety Signage. Courtesy of Hagerman Fossil Beds National Monument.

Always store specimens appropriately and use proper labels and signage that identifies ALL hazardous materials.

6. *Who should I consult for additional safety information?*

For more information, contact your park safety officer, park or regional public health specialist, regional/SO curator, GRD Paleontology Program Coordinator, or the Senior Curator of Natural History.

7. *Are there any special requirements for loans and shipping of radioactive specimens?*

Yes. The U.S. Department of Transportation (DOT) regulates commercial shipments of hazardous materials, including radioactive articles. These regulations also apply to naturally occurring radioactive substances, such as some fossils. All commercial shipments of radioactive specimens must be in accordance with the shielding, packaging, labeling, and other requirements noted in 49CFR173.426.

Note: The DOT regulations do not apply to shipments of specimens by

NPS (or other Federal) employees in a park (or other U.S. Government) vehicle.

If you plan to ship radioactive specimens via commercial carrier (Federal Express, UPS, or another firm), and no one at your park has received hazardous materials transportation training, you will need to hire a certified contractor to prepare any such shipments for commercial transport.

H. Security and Fire Protection of Paleontological Collections

1. *What are the fire and security considerations for paleontological collections?*

Fire and Disasters. Fossils are just as susceptible to damage due to fire and natural disasters as many other collections. Be sure to:

- Always practice fire prevention, including staff training (such as annual extinguisher training).
- Have an appropriate level of fire protection in every structure where specimens are stored and exhibited, preferably a fire suppression system.
- Have an up-to-date Emergency Operations Plan (EOP). Your EOP should include information about the museum collection, including:
 - the special needs of all collections, including paleontological resources
 - all hazardous collections and materials, including locations and any special requirements

Security. Paleontological specimens have a very high monetary value. The market for fossils is similar to the art market. Collectors compete for prize fossils. There is a thriving black market for fossils. As a result, you may need to implement increased security protection for your collection. Discuss the options with your regional/SO curator, park protection staff, and/or regional law enforcement specialist.

Type specimens. Your collection may include type specimens. Type specimens represent a specimen upon which the description of a new type of fossil taxon is based. As such, it is the specimen to which all future specimens will be compared. As a result, they are priceless to science. Designate all type specimens as controlled property.

Designate all type specimens, monetarily valuable specimens, and all exhibited fossils that are particularly vulnerable to damage or theft as controlled property.

For additional information, contact your regional/SO curator, regional structural fire management officer, and regional law enforcement specialist.

2. *How can I determine if certain specimens are monetarily valuable?*

You don't have to hire a professional appraiser. You can obtain a good estimate of a fossil's current "market" value by consulting the web catalogs of commercial fossil dealers. When in doubt, contact the GRD Paleontology Program Coordinator or the Senior Curator of Natural History for advice.

Note: Once you've determined a specimen's market price, be sure to note that information on the ANCS+ catalog record.

3. *Are some specimens at increased risk of theft and/or vandalism?*

Yes. There is an ever-increasing commercial market for fossils. Some types of fossils tend to remain popular. These include trilobites, dinosaur parts, amber, and shark's teeth. Skulls, teeth, leaves, and insects can also command high prices.

As with any item, "commercial value" depends on rarity, quality and type of preservation, completeness, or a unique attribute. Some petrified wood can be considered gemstone quality.

Ultimately, all fossils can be potentially sold. Consider all paleontological resources as vulnerable.

4. *How should I best protect specimens at risk?*

Ensure that all museum areas have an appropriate level of security and fire protection. This includes:

- security, access, and other relevant standard operating procedures
- locks (which are always used) on doors, exhibit cases, and storage cabinets
- electronic fire and intrusion detection systems
- a fire suppression system
- fire prevention and fire and security awareness training for all staff
- an up-to-date Structural Fire Plan, Security Plan, and Emergency Operations Plan

These are just a few of the fire and security measures that your park should undertake. For additional information, consult your regional/SO curator and Chapter 9: Museum Collections Security and Fire Protection.

I. Exhibiting Paleontological Specimens

1. *What should I consider when planning or rehabilitating an exhibit?*

Fossils come in all shapes and sizes. First and foremost, consider how you'll place the specimen in the exhibit. Many specimens like shells are simple in shape and can support their own weight. For other specimens, you may have to construct special supports. You should also consider:

- Does the design specify placing the specimen on the floor of the case or attached to the wall?
- Is there a particular part of the fossil that should be clearly visible to illustrate a certain exhibit topic? The exhibit's theme may determine how to display the specimen.
- Does the fossil have projections that are easily broken or snapped off? If so, you may need to build a custom support to position the specimen for easy viewing.
- In some cases adhesives have been used to attach fossils to the exhibit case's interior.

- Will the adhesive damage the fossil?

Note: Only use adhesives to mount fossils inside exhibits as a last resort. Be sure to consult with an experienced conservator before using any adhesives.

- Can it be easily removed or dissolved without damaging the fossil?
- What is the life of the adhesive?
- If it becomes dry and brittle, is there the potential for the specimen to fall and become broken?

2. *Are there any other exhibit planning considerations?*

Conservation: Be sure that your exhibits are conservation-conscious. Everyone on the planning team (including contractors) must understand that the preservation of the specimen is paramount.

Security: If you plan to mount a complete skeleton, it's critical that you construct a barrier. The barrier must effectively place the specimen beyond the reach of visitors. There is a strong tendency on the part of visitors to want to touch exhibited specimens. Some parts, such as ribs, can be easily grabbed and ends snapped off. Tails are likewise vulnerable.

Also, as noted above, commercially valuable fossils are at increased risk of theft. For unusual or rare specimens on exhibit, you may need to implement additional security measures. Discuss this matter with your regional/SO curator and park law enforcement staff.

3. *Are there any particular environmental concerns for specimens on exhibit?*

Yes. Fossils that retain their original organic constituents, particularly those from the Pleistocene (Ice Age), may be sensitive to high humidity or ultraviolet light. To ensure their preservation, keep relative humidity levels at 45-55% and eliminate all sources of UV light.

4. *Where can I obtain additional information about exhibiting paleontological specimens?*

Consult the following resources:

- Chapter 7: "Using Museum Collections in Exhibits," in the NPS Museum Handbook, Part III: Museum Collections Use
- Exhibit Conservation Guidelines CD-ROM, available from HFC.

See Section III. References, for ordering information

- NPS Geologic Research Division, Paleontology Program Coordinator
 - NPS Senior Curator of Natural History
 - your regional/SO curator
 - conservation staff at the NPS Harpers Ferry Center (HFC)
 - paleontological/curatorial staff at other NPS units
 - paleontological, curatorial, and conservation staff at university, state, or regional natural history museums
-

J. Preparation and Conservation of Specimens

1. *What is preparation?*

Preparation is the process of readying a paleontological specimen for exhibit, curation, or research use. Preparation can include:

- Removing the rock matrix surrounding some fossils. This enables scientists to conduct a more detailed study of the specimen. It also minimizes the amount of dirt and rock introduced into a specimen cabinet.

Note: Some specimens must be left in the rock matrix. This provides critical support and stability to the fossil. Also, it may be impossible to remove some fossils from the surrounding rock, such as a fossil leaf or insect.

- Re-attaching broken pieces.
- Applying some type of preservative or consolidant (also called a hardener). This can strengthen the specimen and make it more durable for handling.

2. *Who can I contact to prepare my park's fossil specimens?*

Consult a trained fossil preparator for assistance. Only an experienced fossil preparator (or a curator who has received such training from a preparator) should prepare specimens. If you do not possess such training, contact the NPS GRD Paleontology Program, your regional/SO curator, the Senior Curator of Natural History, or a local university's paleontology department for assistance, recommendations, and/or training opportunities.



Figure U.4. Preparator preparing a specimen.
Courtesy of Hagerman Fossil Beds National
Monument.

3. *Why should I contact a preparator?*

Fossils differ from other natural history collections; they often require preparation. This is an important intermediate step between their collection in the field and final cataloging and exhibit or storage for research. Only trained professionals should attempt to collect and prepare fossil material. Well-meaning but untrained individuals can easily damage or destroy a specimen. This can rob science of vital data and diminish its value for display, education, or future research.

Protect your collections from such avoidable damage:

- Do not attempt to work on fossils unless you are a trained preparator.
- Do not allow additional preparation to be done by anyone without proof of their qualifications.
- Always document all work done to a specimen and all preservatives used. Keep such documentation in the specimen's catalog folder, accession folder, and/or catalog record. Also, record treatments in the Conservation Module and/or the Preparation Treatment Module of ANCS+ .
- Be sure that you obtain all associated records about any fossil deposited in your collection. These records should include all pertinent preparation data. In addition to the general provenience and catalog data required for ANCS+ , you should maintain a complete preparation history for each specimen. This record should include:
 - any chemical used to clean the specimen
 - a list of all glues and fillers used
 - any comments the preparator may have recorded. Many labs that

do fossil preparation maintain preparation record cards (see Figures U.5 and U.6).

Note: ANCS+ contains a Preparation Treatment Module.

Only trained professionals should attempt to collect and prepare fossil material. Unnecessary damage to the specimen can rob science of vital data and diminish its value for display, education, or future research.

4. *Are there preparators that my park can hire under contract to prepare specimens?*

Yes. You can contract with a museum or university with a fossil preparation laboratory. Parks with paleontology as their focus may have a fully functioning preparation lab. If so, they may be able to assist your park to prepare specimens.

You can hire a trained private practice fossil preparator to work for your park under contract on a project. Check with the Paleontology Program Coordinator in the GRD, the Senior Curator of Natural History, or with paleontologists at other parks on how to proceed if extensive preparation of a specimen is required.

Another option is to use qualified volunteers. Perhaps your park can recruit a retired paleontologist, graduate student, or other individual with fossil preparation skills for the Volunteers-In-Parks (VIP) program. Contact the Paleontology Program Coordinator in the GRD or the Senior Curator of Natural History for assistance.

5. *Are there any special considerations regarding preparation?*

Yes. Fossils should be prepared as quickly as possible. Unprepared fossils are unusable for research, exhibit, or educational purposes and may introduce dust and dirt into storage cabinets.

Also, be aware that:

- Not all glues and consolidants are reversible. Those that contain either alcohol or acetone as a solvent may be reversible. Epoxy adhesives, sometimes used for larger specimens, may not be easily reversed.
- Certain preparation treatments can affect the utility of the specimen:
 - Some hardeners can affect chemical testing.
 - Organic hardeners may contaminate a specimen. This will prevent the use of the Carbon 14 dating technique (for specimens younger than 50,000 years).
 - The ability to extract fossil DNA or study isotopes (to determine the animal's diet) also can be impaired.

Remember: Many specimens were initially prepared according to the original project's research design and/or the specimen's intended

conservation) will not alter or compromise the specimen's relevance to such research or hinder future investigation.

It's impossible to predict what scientific sampling techniques will be developed in the future. Therefore, be sure to keep a permanent record of all chemical treatments applied to the specimen. It then may be possible to remove a chemical at some later date (in order to conduct further analysis).

6. *How much time does it take to prepare a specimen?*

Preparation time depends on the fossil's size, type of preservation, and nature. Such work can be time consuming. A single dinosaur skeleton such as the Allosaurus found at Dinosaur National Monument required 7000 staff-hours of preparation over 4 years. Other types of fossils, such as plant impressions in rock, may require little to no preparation. Other fossils might be ready for exhibit or storage within a matter of days or weeks.

7. *Should I have damaged and/or incomplete specimens repaired?*

Yes, if you don't make necessary repairs, any broken parts can easily become separated and lost. Contact an experienced fossil preparator to repair any broken specimens as soon as possible.

8. *Are there occasions when I should not have a preparator repair a damaged specimen?*

Yes. In some cases repair may not be possible. Store the loose pieces in a properly labeled vial or other container. Depending on the nature of the break, the pieces may be too large or heavy to be reattached (like dinosaur bones).

On rare occasions, breakage may be seen as fortuitous: it permits examination of the specimen's internal structure. In these instances, you may decide against repairing the break.

9. *What's the best way to repair specimens?*

Avoid the need for repair. Make certain that specimens are not damaged in the first place:

- Consistently practice preventive conservation.
- Ensure that all collection users know and use proper handling techniques.

If breakage does occur, take time to determine the cause. Was the breakage:

- accidental (someone bumped into the specimen)?
- due to mishandling (the specimen was handled inappropriately)?
- a result of improper storage or exhibit design? Is the specimen:
 - not in a cradle or other support structure?
 - not properly supported or protected?
 - in a support that needs to be modified?

Remember: The best conservation approach is a preventive one. Once a specimen is broken, it is likely to be broken in the same spot again.

10. *What about applying protective coatings to specimens?*

As noted above, it's appropriate and sometimes necessary to use a hardener or consolidant to strengthen a fossil. This can ensure its long-term stability. However, while the anatomical features may be preserved, such treatments can impact research utility (Carbon 14 dating, isotope studies, or the extraction of DNA).

The best protection for fossils on a flat surface (such as leaves, insects and fish on the bedding plane of shale) is a thin clear coating.

For three-dimensional fossils such as bones, the preparator may need to saturate the specimen with a hardener in order to increase its structural integrity. In these cases, a thin covering may not suffice. If this protective shell is damaged or broken and the specimen lacks internal strength, the entire specimen may crumble.

Once again, you need to consider the intended use of the specimen (exhibit, research, or possibly both) before you make any treatment decisions.

11. *Who should clean specimens?*

To a paleontologist, the cleaning of fossils means the removal of the surrounding rock or matrix during the preparation process, as previously discussed. Once the specimens are prepared, they are subject to accumulating dust, just like other museum objects. To minimize dust on specimens:

- house small specimens in closed storage cabinets
- cover open shelving with plastic sheeting

These actions cannot eliminate all dust. Unless you conduct periodic housekeeping, dust and dirt will accumulate. Consult your park's Museum Housekeeping Plan to determine the frequency that fossil specimens should be periodically cleaned. If you do not have a Housekeeping Plan, or if it is out of date, consult your regional/SO curator, the GRD Paleontology Program Coordinator, the Senior Curator of Natural History, and/or a natural history conservator to establish recommended cleaning guidelines.

From time to time, you'll need to gently vacuum and/or use a soft brush to dust certain specimens. Many larger bones may have fragile processes that are easily broken or snapped. As with all other collections, be very careful whenever removing dust from

SECTION II: GEOLOGICAL COLLECTIONS

A. Overview

1. *What information concerning geological collections will I find in this appendix?*

In this section of the appendix you will find:

- a discussion of the characteristics of geological collections
- guidelines and resources to aid in identifying different types of geological specimens
- tools for recognizing deterioration
- information about proper storage environments
- health and safety concerns
- additional sources of information

2. *Why is it important to practice preventive conservation with geological specimens?*

The general impression that “rocks” are inert, strong, and durable is false. Many geological specimens can be:

- fragile
- chemically active
- easily damaged

3. *How do I learn about preventive conservation?*

Read about the agents of deterioration in Section C and the proper storage of specimens in Section D. See Chapter 3: Preservation: Getting Started, and Chapter 4: Museum Collections Environment, for a discussion on the agents of deterioration. Also refer to Museum Handbook, Part III (MH-III), Chapter 7: Using Museum Collections in Exhibits.

4. *Where can I find the latest information on care of geological specimens?*

Several professional organizations focus on the care of natural history collections, including geological specimens. Such organizations’ publications often contain articles on the care of geological specimens. Examples include:

- The Society for the Preservation of Natural History Collections (SPNHC) publishes Collection Forum
- The Geological Curators’ Group in England publishes a newsletter, The Coprolite and a technical series, The Geological Curator.

Refer to Section III of this appendix for additional information.

B. Geological Collections

1. *What types of geological specimens are generally found in park collections?*

Since all parks have geology, there's always the potential for geological specimens in a park's collection. Geological collections can include:

- rocks (igneous, sedimentary, and metamorphic)
- mineral specimens (including crystals)
- ores
- cave formations and minerals
- samples of geological formations
- soils
- building stone samples

2. *What is a rock?*

A rock is an aggregate of one or more minerals or a body of undifferentiated mineral matter. Rocks are divided into three different types:

- **Igneous Rocks** solidified from molten or partly molten material. Examples include:
 - basalt lava flows found at Hawaii Volcanoes, Craters of the Moon, El Malpais, Lava Beds, and Devil's Postpile
 - lava bombs (features associated with lava flows)
 - granite at Yosemite
 - obsidian at Yellowstone
- **Sedimentary Rocks** result from the consolidation of loose sediment that has accumulated in layers. Sedimentary rocks are divided into:
 - clastic rocks formed by the mechanical breakdown of fragments of older rock, such as sands and shales
 - chemical rock formed by the precipitation of minerals such as gypsum or limestone from solution
 - organic rock formed by the secretions of plants or animals or accumulations of organic matter such as coal or shell fragments called coquina used in the construction of the fort at Castillo de San Marcos

Examples include sandstones in Glen Canyon, limestones at Guadalupe Mountains, dolomites, shales, clays like bentonite at Bighorn Canyon and Cuyahoga Valley, and coal at New River Gorge.

Some parks have loose sands and sand dunes. Samples of sand may be collected and placed in the park collection such as the gypsum sand at White Sands or silica sands at Great Sand Dunes or Sleeping Bear Dunes.

- Metamorphic Rocks are modified pre-existing rocks. They undergo metamorphosis in response to marked changes in temperature, pressure, shearing stress, and chemical environment. Examples include:
 - gneiss and schist in the Grand Canyon
 - marble at Oregon Caves, Great Basin, and Mojave

3. *What is a mineral?*

Characteristics of minerals include:

- naturally occurring inorganic element or compound
- orderly internal structure
- characteristic chemical composition
- crystal form
- physical properties

Examples include pyrite (also known as “Fools Gold”) from Prince William Forest and borate minerals from Death Valley. Today, over 4,200 different types of minerals are known to science.

4. *What are ores?*

Ores are the natural material from which a mineral of economic value can be extracted at a profit. In general, the term is used to refer to metal-bearing rock. Many parks have historic mines and samples of ores from these mines may be present in the park collection. Copper ores are known from Delaware Water Gap, Keweenaw, and Wrangell-St. Elias. Prince William Forest has a historic pyrite mine.

5. *Why do some collections include cave formations?*

Even though NPS policy is to ensure that all cave minerals and formations are managed in place, many parks with caves will have examples of cave formations (stalactites, stalagmites, cave pearls) or minerals in their collections. Often these specimens were salvaged during trail construction or other similar activities.

Most cave formations are composed of calcium carbonate but may be formed by either calcite (more commonly) or aragonite (rarer) crystals. Cave formations composed of aragonite are more fragile and subject to damage. There are a variety of cave minerals. Depending on their chemical composition, they may require special conditions for their preservation.

Cave formations and minerals are in the collections at Mammoth Cave and Carlsbad Caverns. A good reference for helping with the identification of cave formations and minerals is *Cave Minerals of the World* by Carol Hill and Paolo Forti (1997).

6. *Why do some collections contain quarried stone?*

Some parks like Harpers Ferry and Acadia have historic stone quarries that were used in building construction. Examples of the rock types from these quarries may be placed in the park collection. Other parks, such as Alibates Flint Quarries, may have prehistoric quarries where chert or flint was mined by Native Americans or the catlinite quarry at Pipestone. Reference samples of this rock material may be placed in park collections.

7. *How do I identify the different types of specimens?*

You may need a geologist or mineralogist to help you identify a particular mineral, but the standard reference for mineral identification is: Dana's New Mineralogy: The System of Mineralogy of James Dwight Dana and Edward Salisbury Dana by Richard V. Gaines et. al. (1997).

C. Factors That Contribute to Specimen Deterioration

1. *What agents of deterioration affect geological specimens?*

Deterioration can result from:

- Physical damage resulting from improper storage or handling
- Chemical changes, depending on the chemical composition of the specimen and the environment in which it is stored.

2. *How can I identify active deterioration?*

Look for:

- physical changes in the specimen, such as changes in size or shape
- “growth” of new minerals on the surface
- spalling
- breakage
- powdery residues
- change in color
- change in translucency
- swelling
- uncharacteristic odors

Also, look for darkening, embrittlement, and shrinkage of old coatings and adhesives. These can be very damaging to geological collections.

3. *How can I protect my specimens from deterioration?*

The best approach is to maintain:

- proper storage
- climate control systems
- an active environmental and Integrated Pest Management (IPM) monitoring program

Begin at the microenvironmental level and work outward. If you have a limited budget, you may have to start small. First, invest in archival-quality enclosures and trays. If you have additional funding available, perhaps you can purchase new storage cabinets. The perfect scenario, if funding is appropriate is:

- a heating and cooling system that maintains appropriate environmental conditions facility-wide
- proper storage cabinets
- archival-quality enclosures and trays

No matter what your park can afford, be sure to take the time to maintain accurate records of your museum facilities' environments, including:

- temperature
- relative humidity
- visible and UV light
- IPM

4. *What is the best relative humidity and temperature for my specimens?*

Maintain a stable storage environment:

- temperature of 59° - 77°F
- relative humidity at 45-55%

Relative humidity may not be a critical factor in the storage of most geological specimens. However, some anhydrous (water-free) minerals will absorb moisture from the atmosphere. Store these specimens in a cabinet or room that is maintained in a low humidity environment. You may need to place trays or packages of silica gel or some other desiccant in the cabinet to help reduce humidity levels. Conduct regular monitoring. Remember to regularly check and recondition or replace the silica gel, as needed. For additional information, see COGs 1/8 "Using Silica Gel in Microenvironments" and 2/15 "Cobalt Indicating Silica Gel Health and Safety Update."

5. *Should I be concerned about atmospheric pollution?*

Yes. Both gaseous and particulate pollutants can accelerate deterioration, especially if they are acidic or caustic. Many minerals, including calcium carbonate, are highly susceptible to reactions with acids. Particulates can lodge on surfaces and surface coatings, which you'll need to clean off (this

is never a risk-free procedure [see below]).

In addition, some geological specimens are themselves sources of gaseous pollutants:

- mercury vapor is readily liberated from cinnabar
- a number of uranium-series minerals release radon
- asbestos-containing minerals may break down enough to release inhalable particles

Monitor all specimens known to contain hazardous substances. Seek expert advice. Remember that such items may require separate storage (or transfer to a more appropriate facility).

6. *Does cleaning contribute to deterioration?*

Yes. Both custodial (room-level) cleaning and specimen (preparation-level) cleaning can expose the specimen to rough handling and caustic materials. Maintenance chemicals that can cause severe damage to specimens include: chlorine bleach, ammonia, other cleaning agents, waxes, and related materials. Whenever possible, utilize nontoxic cleaning alternatives (see COG 2/21 “Safer Cleaning Alternatives for the Museum and Visitor Center”). Carelessness and improper techniques can cause damage through vibration and impact.

Remember that specimen cleaning is an irreversible process in many instances. Cleaning can cause loss of:

- matrix
- parts of the actual specimen
- associated trace material

Don't clean a specimen just to keep up a routine. Ask yourself if cleaning really is necessary. If not, don't do it.

7. *Are there any other deterioration concerns?*

Some sulphate-based cave minerals such as selenite (calcium sulphate) and epsomite (magnesium sulphate) readily absorb water from the atmosphere and can disintegrate. To prevent deterioration, any mineral that can potentially absorb water must be stored in a low humidity environment. For additional information, see Holmberg (2000) and Jerz (2000), noted in the bibliography.

D. Handling and Storage of Geological Collections

1. *What do I need to know about handling specimens?*

Weight

Depending on the size of the specimen, weight can be a major factor. You may need to access heavily loaded cabinet drawers. Be sure not to overload drawers; consult the manufacturer's recommended weight loads and do not exceed them. Always use extreme caution; due to its weight, if a specimen

shifts it may cause the drawer to tip.

Transport

Never carry specimens to a table or other area. Use a wheeled, sturdy cart with a padded surface to transport specimens between storage cabinets and exhibit or research areas.

Handling

Protect the specimen. Practice limited handling. Specimens should spend as little time outside storage cabinets or exhibit cases as possible. Only handle specimens on or over a work surface.

Gloves

Contrary to standard handling practice with other museum collections, DO NOT wear cotton gloves when handling geology specimens. The specimen may be slippery, and you could easily drop it. Use your clean, bare hands to assure a good grip.

Lab Coats and Other Protective Outerwear

Wear a labcoat or other type of protective outer garment when handling collections. This will help to minimize deposits of particulates and dirt on your clothing. Wearing a labcoat also helps to protect the specimen from damage due to contact with badges, jewelry, and belt buckles. Another option is to wear a Tyvek® “jumpsuit,” sold in paint stores.

2. *How should I store specimens?*

Use standard geology cabinets for most specimens (see Tools of the Trade for additional information). As with other collection items, you can store small specimens in trays, cavity-packed in polyethylene foam. This is a good idea for items that may require more frequent access and transport for research purposes.

For larger specimens, you'll probably need to use open shelf storage. Very large specimens such as pieces of building stone or larger ore samples may require their own pallet for support. To move these specimens, you'll need a pallet jack.

Since a specimen may spend well over 95% of time in storage, proper storage systems are a wise long-term investment. As with all collections, inappropriate storage materials put the specimen at risk. Always use acid-free, inert storage materials and housings. Cabinetry should be of steel construction, with high gloss, epoxy powder coatings.

3. *What additional protection do geological specimens need in storage?*

- In general, don't leave a specimen on a bare surface exposed to the open lab conditions.
- Make sure that specimens (particularly large ones) are not supporting their weight on appendages, attachments, or other weak areas.
- Pad surfaces with inert closed-cell polyethylene foam (such as Volara® or Plastizote®).
- Use closed storage wherever possible.
- For large specimens, use custom-made reinforced fiberglass jackets (the same principle as cavity packing, but on a much larger scale).

This facilitates open shelf storage.

- Place smaller specimens in specimen trays.

Protection from high and/or fluctuating temperature and relative humidity are important for all specimens. Other threats include:

- UV exposure
 - water
 - fire
 - theft and vandalism
 - related factors
-

E. Health and Safety Issues

1. *What health and safety issues are related to geological specimens?*

Some minerals may contain elements that are toxic. The most common ones are:

- Aluminum
- Antimony
- Arsenic
- Beryllium
- Bismuth
- Bromine
- Cadmium
- Lead
- Mercury
- Selenium
- Thallium
- Uranium

Handle all of these minerals with care.

Many parks have historic mines that extracted minerals that may be considered hazardous to human health. Some examples include:

- Cinnabar, which is a mercury sulfide (HgS) mineral.

- Arsenopyrite (FeAsS), which includes arsenic.
- Asbestos, which is a variety of fibrous, nonflammable minerals with flexibility and high tensile strength. Asbestos includes minerals such as chrysotile, amphibole, and crocidolite.

Specimens of these economically important minerals related to historical mining in the parks may be present in park collections and used in park exhibits.

2. *How can I best protect the health of staff and researchers using potentially toxic collections?*

Make sure that a mineral has been properly identified and that you are aware of its chemical composition. If a mineral does contain potentially toxic elements, always wear neoprene gloves when handling it. Be sure to wash your hands after you finish handling any other minerals with bare hands, as a precaution. As with all collections, never allow food or drink around mineral specimens.

Always wear neoprene gloves when handling minerals that contain potentially toxic elements.

3. *What other safety concerns should I consider?*

Take into account the following:

Heavy Metals

Heavy metals cause problems by displacing or replacing related minerals that are required for essential body functions. For example, cadmium can replace zinc, and lead displaces calcium. When this happens, cadmium or lead is stored in the bones or other tissues and becomes difficult to remove from the body. At the same time, the important functions of the minerals that are replaced cannot be carried out.

Toxic Gases

Some minerals may release gases or vapors. In a closed specimen cabinet, this can generate high concentrations of toxic gases. These can include:

- acidic vapors (thought to be primarily carboxylic acid vapors)
- mercury vapor
- sulfur dioxide
- hydrogen sulfide, the gas that tarnishes silver

Label all cabinets housing such minerals with the appropriate National Fire Protection Association (NFPA) Hazard Warning Symbol. This will ensure that all personnel (staff, visitors, and emergency workers) are aware of these potential hazards.

Note: See Chapter 11: Curatorial Health and Safety, Figure 11:4 on page 11:45, for an example of the NFPA Hazard Warning Symbol System.

Also, be sure to note the presence of these minerals in relevant emergency

planning documents (such as your Museum Emergency Operations Plan [MEOP]) and brief all first responders on their presence and locations.

Mineral Dust

Inhaling mineral dust may be more of a hazard than handling the specimen. The amount of dust depends on how friable the specimen is and how it is handled. For example, handling may release asbestos fibers. Although mineral dust may not be a primary problem in museum collections, at times it may be important to use a good quality respirator when handling specimens, especially if they are being cut or trimmed.

Note: Before you can use a respirator, you must first undergo a medical evaluation, formal training, and fit testing. For additional information concerning respirator use, see COG 2/13.

4. *Could some specimens be radioactive?*

Yes. Many parks contain radioactive minerals or ores. Some examples of common radioactive minerals include:

- Autunite (hydrated calcium uranium phosphate)
- Brannerite (uranium titanate)
- Carnotite (potassium uranium vanadate)
- Monazite (a mixed rare earth and thorium phosphate)
- Thorianite (thorium dioxide)
- Uraninite (uranium dioxide)

The vast majority of the radioactive content in minerals or ores is either uranium-238 or thorium-232, although other radioactive elements may be present. Uranium minerals are found in Blue Ridge Parkway, and many western parks such as Canyonlands have abandoned uranium mines, so it is possible that uranium minerals will be present in park collections.

5. *What terms should I know that are relative to radioactivity?*

Radioactivity is the spontaneous release of particles and energy by the nucleus of an unstable atom. This is part of a natural decay process in which an unstable element is transformed into a stable element, such as uranium-238 becoming lead-206. There may be a number of intermediate stages or daughter elements.

Radiation in the common sense refers to *ionizing radiation*: a term for invisible particles or waves with enough energy to strip electrons from atoms, causing chemical changes. The three basic types of natural radiation are alpha, beta, and gamma. There are also X-rays and neutrons.

An alpha particle is composed of two protons and two neutrons—essentially it's a helium nucleus, an ionized helium atom (a helium atom devoid of its electrons and having a net charge of + 2). Alpha particles are comparatively large and cannot penetrate much more than a sheet of paper or a few inches of air. However, they are extremely potent ionizing agents because they interact with plenty of matter in their [short] path.

A beta particle (actually a “beta-minus” particle, since it has a charge of -1) is a stray electron originating from an atom’s nucleus as the result of neutron breakdown. “Beta-plus” particles are positrons or “positive electrons,” something seldom encountered in nature. Beta radiation can be stopped by a few centimeters of wood, plastic, or glass. A few millimeters of aluminum will also stop most beta particles.

Note: Do not use lead or other highly dense materials to shield from beta radiation. Certain types of shielding can actually be worse than none. Lead and other dense metals (including tungsten) can emit X-rays when exposed to beta particles such as those thrown out by the natural decay products of U-238 and Th-232. This phenomenon is called *bremsstrahlung*. If the lead is thick enough, the X-rays won’t get out the other side of it. Nevertheless, if you’re going to use shielding for a mineral display, it’s best to make it out of wood or acrylic (Plexiglas®).

Gamma radiation is composed of high-energy photons (invisible light; electromagnetic waves). It has no charge, but its high energy means that it can cause ionization. Fortunately, gamma rays move so fast and have such energy that they often pass right through matter without interacting at all.

6. *How can I determine if specimens are radioactive?*

It’s vital to correctly identify a mineral’s composition. If you have a specimen that you suspect is radioactive, confirm its identification with a trained mineralogist. Most university geology departments include a mineralogist on the faculty. The crystal structure, color, and other physical properties may permit a quick identification. If a Geiger counter or scintillator is available, you can use it to detect the presence of radioactive particles. If you do not have access to a Geiger counter or a mineralogist, use the procedure to detect radioactivity in specimens proposed by Blount (1990):

Place the specimen on a small piece of unexposed black-and-white photographic film in a lightproof sleeve and then have it developed to check for fogging.

7. *What is radon?*

Radon is a naturally occurring radioactive gas that is colorless, odorless, tasteless, and chemically inert. It is found in soils, rock, and water throughout the U.S. Because radon occurs throughout the nation, it’s possible that specimens in your collection emit radon. Radon has a half-life of only 3.5 days, but when a radon-emitting sample is stored in a closed specimen cabinet, radon levels may come to equilibrium over time. The actual amount of radon will depend on the number, volume and chemical composition of the radioactive mineral specimens stored in the cabinet.

30 CFR, Part 57, Subpart D regulates occupational levels of alpha and gamma radiation in underground uranium mines. Occupational yearly exposure per individual shall not exceed 4 WLM (working level month) alpha or 5 REM (Roentgen Equivalent Man = the amount of ionizing radiation that when absorbed by a person is equivalent to one roentgen or x-ray or gamma radiation) gamma. While these levels may not exist in most park collections, they do provide a standard by which staff safety can be measured. Generally the EPA typically recommends 10% of occupational limits for the general public.

If you have concerns regarding occupational exposure to radioactive specimens in your park’s collection, consult with an industrial hygienist,

NIOSH, and/or the U.S. Public Health Service specialist duty-stationed in your park or region.

8. *How should I protect staff and the public from radioactive specimens?*

Never be careless around radioactive materials. Follow these general rules:

- Minimize all contact with radioactive specimens.
- Protect everyone from breathing in radon or inhaling or ingesting other radioactive particles.
 - Do not crush, saw, or grind radioactive minerals so as to cause their dust to enter the air, especially indoors.
 - As with all museum specimens, never smoke, drink, or eat while handling radioactive minerals.

Note: Inhalation of radon or breathing in or ingesting radioactive minerals or their dust is the most likely method of radiation exposure.

- Wear latex or nitrile gloves whenever handling radioactive specimens.
- Always wash your hands after handling radioactive minerals.
- Work to minimize deposits of radioactive particulates on staff:
 - Always wear a labcoat or other protective outer wear.
- Store all radioactive specimens appropriately. Post proper labels and signage (see Figure U.3. above). Make sure that everyone knows the nature of the materials that they might be handling. Be sure to provide everyone accessing these collections with guidance on handling, precautions, and procedures.
- You may need to store radioactive specimens in a special cabinet with a venting systems (see Figure U.3.). Refer to Conserve O Gram 2/5 "Fossil Vertebrates as Radon Sources: Health Update" for additional information.
- If possible, store radioactive specimens in a separate, secured room that is vented to the outdoors.

Additional Important Safety Notes:

The general rules stated above are NOT adequate for specimens emitting high levels of radiation. Consult an industrial hygienist or the National Institute for Occupational Safety and Health (NIOSH) for assistance developing appropriate control measures.

Contact NIOSH by telephone at: (800) 356-4674 or on the web at: < <http://www.cdc.gov/niosh/homepage.html> > .

NIOSH also conducts Health Hazard Evaluations (HHE). A HHE is the study of a workplace to see if workers are exposed to hazardous materials or harmful conditions. To request a HHE, or for more information, see the HHE Program website at: < <http://www.cdc.gov/niosh/hhe/default.html> > .

Requests for a HHE must be in writing. The HHE Program website includes an on-line HHE Request Form.

For additional information concerning a HHE relative to geological and paleontological collections, refer to:

Jiggins, Timothy, E., John J. Cardarelli, and Steven H. Arhrenholz. NIOSH Health Hazard Evaluation Report: Hagerman Fossil Beds National Monument, National Park Service, U.S. Department of the Interior, Hagerman, Idaho, HETA 96-0264-2713. Cincinnati: National Institute for Occupational Safety and Health, 1998. Available on the web at:
< <http://www.cdc.gov/niosh/hhe/reports/pdfs/1996-0264-2713.pdf>> .

Remember:

- There is an inverse square relationship between the level of exposure to radiation from a mineral and the distance you are from it. Radiation levels drop off dramatically the farther you are from the specimen.
- If you're going to use shielding for a radioactive mineral on exhibit, it's best to make it out of wood and/or acrylic (Plexiglas®).

Always store specimens appropriately and use proper labels and signage that identifies ALL hazardous materials

9. *Are there any other human health risks associated with geological specimens?*

Some specimens of rocks or minerals are large and difficult to move. You may want to store such specimens on pallets and use a pallet jack or forklift to move them. Always follow proper safety precautions. Use appropriate techniques and equipment.

F. Security Concerns

1. *Are some types of specimens at increased risk of theft and/or vandalism?*

Gold nuggets and silver specimens have commercial value; store them in a safe. Other minerals may be vulnerable, including:

- certain rare and valuable mineral specimens
- minerals with good crystal structure
- some minerals of gemstone quality
- small specimens, which are easier for a thief to pick up and steal

2. *How should I best protect specimens at risk?*

You may wish to have a professional mineral appraiser examine your collections. An appraiser can provide an indication of the market value of specimens. Appraisals can help you to decide which specimens may require increased levels of security.

As noted above, some specimens should not be stored with other items. Rather, they require their own secure storage areas. Specimens that may

require separate storage include radioactive specimens and those that produce gases.

For additional information concerning museum security, refer to Chapter 9: Museum Collections Security and Fire Protection.

G. Exhibiting Geological Specimens

1. *What should I consider when planning an exhibit?*

Geology exhibits usually focus on two broad interpretive themes:

- Processes. The specimens illustrate a process such as erosion or volcanic activity.
- Objects. The exhibit focuses on the specimens themselves, such as examples of different rock types or mineral ores.

Do not select specimens for exhibit until the exhibit planning team has developed interpretive themes. As the Exhibit Plan progresses, the planning team can then decide how each specimen can best illustrate the story being told.

Always consider the durability of a specimen and its value when deciding how to exhibit it (either as a touch specimen or in an exhibit case).

2. *Are there any particular concerns for exhibiting geological specimens?*

Many geological specimens are relatively inert; they don't require any special conditions. Often, because of their durability, geological specimens are used as touch exhibits. Make sure that specimens selected for use as touch specimens do not contain any toxic or radioactive substances. Place fragile specimens (such as some smaller crystals) inside an exhibit case. Massive crystals such as quartz may be suitable for a touch exhibit.

3. *Are there any specific situations that I should avoid when exhibiting geological specimens?*

Do not assume that all objects classified as geological specimens are the same. Know the properties of each specimen and how these different properties can affect the potential for damage. This includes damage from environmental conditions, improper display, or inappropriate handling.

4. *What should I know about cleaning geological specimens?*

The care and cleaning of specimens on exhibit is similar to that of other objects. Dry dusting and vacuuming may be appropriate for larger specimens but not for smaller fragile specimens. A damp cloth may be appropriate for some rock types but not water-soluble minerals like certain types of salts.

Practice preventive conservation. A proper exhibit case design can prevent dust accumulation. This approach is preferable to cleaning specimens after they become dusty. Know the composition of the specimen and its degree of durability prior to any decision on how it should be cleaned.

H. Conservation of Specimens

1. *When should I contact a conservator?*

Contact a geological conservator if you notice any signs that the specimen is reacting to environmental conditions such as:

- new crystal growth
- deterioration of labels or storage materials

A trained geological conservator may be able to provide simple corrective steps that will address the immediate problem or determine if more serious treatment is warranted. For example, if there is active deterioration of the specimen, the conservator may be able to determine if it is the result of environmental conditions in storage or other causes. Proper diagnosis of the problem is critical in order to correct the situation.

2. *Should park staff repair damaged and/or incomplete specimens?*

Do not attempt any specimen repairs yourself. The various glues and adhesives in common use can cause long-term damage to the specimen. If the specimen is intended solely for exhibit, you may be able to have a conservator repair it. However, it's vital to ensure that specimens used in research are not chemically contaminated. Do not use any adhesives (or any other chemical additives) on such specimens.

Remember: Many specimens were initially prepared according to the original project's research design and/or the specimen's intended use. Be sure that any proposed treatments (including preventive conservation) will not alter or compromise the specimen's relevance to such research or hinder future invagination

3. *What types of repairs can a conservator undertake?*

A conservator can:

- recommend what can (and cannot) be done for the specimen
- advise you if conservation work is necessary
- do advanced cleaning and stabilization. Such work may be beyond even the resources of a park that has its own laboratory and trained staff.
- undertake delicate repairs and infills of specimens. Note: Infills, reconstructions and replacement of missing parts may be acceptable for exhibition and interpretive uses. Any such repairs should be:
 - easily distinguishable from the original specimen
 - inert
 - reversible

Exhibiting repaired specimens also may require you to alter or revise related interpretive elements. Each specimen creates its own set of concerns and issues.

4. *What type of damage is beyond repair by a conservator?*

A conservator cannot undo irreversible damage. Such examples include:

- fading caused by UV exposure
- breaks

Breaks are irreversible. They do not “go away” when the specimen is glued back together.

5. *Should protective coatings be applied to specimens?*

As a general rule, protective coatings are not currently applied to geological specimens. Older specimens may have been coated with a variety of poor-quality substances, including shellac, waxes, oils, films, and spray-on polymers.

6. *What about cleaning specimens?*

Many larger, hardier specimens (like rocks and ores) can withstand occasional cleaning. In some cases, trained park staff can clean specimens. Appropriate methods, techniques, cleaning supplies, and equipment vary with the chemical composition of the specimen. For example:

- Don't use water to clean certain minerals, such as salt minerals like halite (sodium chloride) or gypsum (calcium sulfate) because they are soluble in water.
- Specimens with small delicate crystals may require procedures to remove dust and dirt.
- Ultrasonic cleaners can be used to clean some small crystal specimens. The technique used depends on the minerals (Hansen, 1984).

Before starting, be sure to consult your park's Museum Housekeeping Plan. It will help you determine:

- which specimens you can safely clean
- which specimens should only be cleaned by a conservator (or some other specially trained individual)
- the frequency that specimens should be cleaned
- appropriate method, techniques, supplies, and equipment.

If you do not have a Housekeeping Plan, or if it's out of date, consult your regional/SO curator, the NPS Geological Resources Division, and/or a natural history conservator to establish recommended cleaning guidelines.

SECTION III. REFERENCES

A. National Park Service Resources

- Geologic Resources Division, Paleontology Program
P.O. Box 25287
Denver, Colorado 80225-0287
www2.nature.nps.gov/geology/paleontology
 - Senior Curator of Natural History, Park Museum Management Program
1201 Oakridge Drive, Suite 150
Fort Collins, Colorado 80525
(970) 267-2167
 - Your regional/SO curator
-

B. Professional Organizations

The Society of Vertebrate Paleontology has a preparators' group and a special session at their annual meetings to discuss fossil preparation and related topics. Contact the society at:

Society of Vertebrate Paleontology
60 Revere Drive
Suite 500
Northbrook, IL 60062
www.vertpaleo.org

The Society for the Preservation of Natural History Collections (SPNHC), represents the interests of natural history collections and the people associated with the management and care of these collections. Publications include Collection Forum and SPNHC Newsletter. SPNHC's annual meetings include formal presentations and workshops. Contact SPNHC at:

Society for the Preservation of Natural History Collections
PO Box 797
Washington, DC 20044
www.spnhc.org

The Paleontological Society is an international association dedicated to the science of paleontology. The organization publishes the Journal of Paleontology, Paleobiology, The Paleontological Society Memoirs, Short Course Notes, and various other special publications. The society holds an annual meeting, as well as regional meetings. Contact the society at:

The Paleontological Society
PO Box 7075
Lawrence, KS 66044
(785) 843-1235 ext. 297
www.paleosoc.org

The Paleobotanical Section of the Botanical Society of America is an organization of individuals concerned with fossil plants. The section

publishes the Bibliography of American Paleobotany, as well as other materials and special publications. The Paleobotanical Section holds workshops and conferences at the annual meeting of the Botanical Society of America. For additional information, refer to their website at: < www.dartmouth.edu/~daghlian/paleo > .

The Mineralogical Society of America promotes scientific research, teaching, and educating the public concerning mineralogy. The Society publishes *American Mineralogist*, *Reviews in Mineralogy and Geochemistry*, monographs, a newsletter, and books. It holds courses, lectureships, symposia, and meetings. The organization also gives grants and awards. For further information, contact the society at:

Mineralogical Society of America
1015 18th Street, NW, Suite 601
Washington, DC 20036
(202) 775-4344
www.minsocam.org

The Geological Curator's Group in England was established in 1974 to improve the status of geology in museums and raise the standard of geological curation. Their goals are to advise, inform, and create a forum for discussion for all aspects of the care of geological collections as an irreplaceable part of our scientific and cultural heritage.

The Geological Curator's Group is affiliated to the Geological Society of London. For further information, refer to the Group's website at: <<http://www.hmag.gla.ac.uk/gcg>> .

C. Glossary

- Body fossil:* the preserved remains of any anatomical part of a plant or animal.
- Carbonization:* the accumulation of residual carbon from a plant or animal by changes in the organic matter and decomposition products.
- Consolidant:* any type of material, often a plastic or shellac, used to harden and strengthen a specimen. Applied by either specimen immersion or surface application.
- Fossil:* any remains, trace or imprint of a plant or animal that has been preserved in the earth's crust since some past geological time.
- Mineral:* a naturally occurring inorganic element or compound having an orderly internal structure and characteristic chemical composition, crystal form, and physical properties.
- Ore:* the natural material from which a mineral or minerals of economic value can be extracted at reasonable profit. Usually applied to metalliferous material.

- Permineralization:* a process of fossilization whereby the original hard parts of a plant or an animal have additional material deposited in their pore space.
- Pyrite disease:* humidity-driven oxidation of pyrite (iron sulfide) that affects the microcrystalline or framboidal forms that change the iron sulfide to iron sulfate.
- Replacement:* a process of fossilization involving the substitution of inorganic material for the original organic constituents of an organism.
- Rock:* an aggregate of one or more minerals or a body of undifferentiated mineral matter. Rocks are divided into three different types: igneous, sedimentary and metamorphic.
- a. *Igneous Rock:* rocks or minerals that solidified from molten or partly molten material.
- b. *Sedimentary Rock:* a rock resulting from the consolidation of loose sediment that has accumulated in layers. Sedimentary rocks are divided into:
- clastic rocks formed by the mechanical breakdown of fragments of older rock such as sands and shales
 - chemical rocks formed by the precipitation of minerals such as gypsum or limestone from solution
 - organic rocks formed by the secretions of plants or animals or accumulations of organic matter such as coal.
- c. *Metamorphic Rock:* any rock derived from pre-existing rocks by mineralogical, chemical and/or structural changes, essentially in the solid state, in response to marked changes in temperature, pressure, shearing stress, and chemical environment.
- Trace fossil:* a sedimentary structure resulting from the life activity of an animal such as a track, trail, burrow, tube, boring or tunnel, or marks on other fossils indicating feeding or chewing activities or the preserved feces of an animal.

D. Web Resources

The National Institute for Occupational Safety and Health (NIOSH)
<http://www.cdc.gov/niosh>

NIOSH Health Hazard Evaluation (HHE) Program
<http://www.cdc.gov/niosh/hhe>

Quality Condition Score for Paleontology/Geology collections
<http://fenscore.man.ac.uk/Formspage1.htm>
<http://fenscore.man.ac.uk/FORMF3.htm>

Fossil Plant Preservation
<http://www.ucmp.berkeley.edu/IB181/VPL/Pres/Pres2.html>
<http://www.korrnet.org/kgms/feb-01/feb01-8.htm>

Radioactive Minerals
<http://www.crscientific.com/radiation.html>

Mineral Dust
<http://www.minsocam.org/MSA/RIM/Rim28.html>

E. Bibliography

- Bates, R.L. and J.A. Jackson (editors). *Glossary of Geology* 2nd edition. Falls Church, Virginia: American Geological Institute, 1980.
- Bennett, Karen L. *Conserve O Gram* 1/8 "Using Silica Gel in Microenvironments." Washington, DC: National Park Service, 1999.
- Birker, I. and J. Kaylor. "Pyrite Disease: Case Studies from the Redpath Museum." In *Proceedings of the 1985 Workshop on the Care and Maintenance of Natural History Collections. Life Sciences Miscellaneous Publications*, edited by J. Waddington and D.M. Rudkin, 21-27. Toronto: Royal Ontario Museum, 1986.
- Blount, A.M. "A Low-Cost Radioactivity Test for Geological Specimens." *Collection Forum* 6, no. 1 (1990).
- Burke, John. *Conserve O Gram* 3/9 "Anoxic Microenvironments: A Treatment for Pest Control". Washington, DC: National Park Service, 1999.
- Buttler, C.J. "National Museum of Wales Specimen Condition Survey Form for Geological Collections." *Collection Forum* 1, no. 1 (1995).
- Carman, M.R. and J.D. Carman. "Health Considerations of Radon Source Fossil Vertebrate Specimens." *Collection Forum* 5 no. 1 (1989).
- Child, R.E. (ed.). *Conservation of Geological Collections*. London: Archetype Publications Ltd., 1994.
- Chure, Dan. *Conserve O Gram* 2/5 "Fossil Vertebrates as Radon Sources: Health Update." Washington, DC: National Park Service, 1993.
- Collins, C. *Care and Conservation of Palaeontological Material*. London: Butterworth-Heinemann Publishing, 1995.
- Donovan, S.K. (ed.). *The Process of Fossilization*. New York: Columbia University Press, 1991.
- Elder, Ann et al. "Adhesives and Consolidants in Geological and Paleontological Applications." *Society for the Preservation of Natural History Collections Leaflet* 1, no. 2 (1997).
- Feldmann, R.M., R.E. Chapman and J.T. Hannibal (eds.). *Paleotechniques. The Paleontological Society Special Publication No. 4*, 1989.
- Fitzgerald, G. R. "Documentation Guidelines for the Preparation and Conservation of Paleontological and Geological Specimens." *Collection Forum* 4, no. 2 (1988).
- Floray, Steven P. *Conserve O Gram* 2/21 "Safer Cleaning Alternatives for the Museum and Visitor Center." Washington, DC: National Park Service, 2003.
- Gaines, Richard V. et. al. *Dana's New Mineralogy: The System of Mineralogy of James Dwight Dana and Edward Salisbury Dana*. New York: Wiley, 1997.

- Hall, Kathy. Conserve O Gram 11/2 "Storage Concerns for Geological Collections." Washington, DC: National Park Service, 1998.
- Hansen, Mogen. "Cleaning Delicate Minerals." *Mineralogical Record* 15, no. 2 (1984).
- Hawks, Catharine and Tim Radtke. Conserve O Gram 2/13 "An Introduction to Respirator Use in Collections Management." Washington, DC: National Park Service, 2000.
- Hebda, R.J. "Museum Collections and Paleobiology." In *Museum Collections: Their Roles and Future in Biological Research*, British Columbia Provincial Museum Occasional Paper No. 25, edited by E.H. Miller, 93-111. Victoria: British Columbia Provincial Museum, 1985.
- Hill, Carol and Paolo Forti. *Cave Minerals of the World*. Huntsville: National Speleological Society, 1997.
- Holmberg, I.C. "Different Degradation Effects on Miocene Whale Skeletal Remains from Gram, Denmark, Caused by the Clay Matrix." *Collection Forum* 14, nos. 1-2 (2000). Available on the web at: http://www.spnhc.org/documents/CF14-1_2.htm.
- Howie, F.M.P. Safety Considerations for the Geological Conservator. *Geological Curator* 4, no. 7 (1987): 379-401.
- _____. "The Care and Conservation of Geological Material: Minerals, Rocks, Meteorites and Lunar Finds." London: Butterworth-Heinemann Publishing, 1992.
- Jerz, Jeanette K. Rate of Pyrite Oxidation In Air. Blacksburg, VA: Department of Geological Sciences, Virginia Tech University, 2000. On the web at: <http://www.geol.vt.edu/research/gssrs/gssrs2000/abstracts/jjerz.html>.
- Jiggins, Timothy, E., John J. Cardarelli, and Steven H. Arhrenholz. NIOSH Health Hazard Evaluation Report: Hagerman Fossil Beds National Monument, National Park Service, U.S. Department of the Interior, Hagerman, Idaho, HETA 96-0264-2713. Cincinnati: National Institute for Occupational Safety and Health, 1998. Available on the web at: <http://www.cdc.gov/niosh/hhe/reports/pdfs/1996-0264-2713.pdf>.
- Leiggi, P. and P. J. May (eds.). *Vertebrate Paleontological Techniques, Volume 1*. Cambridge: Cambridge University Press, 1995.
- Litwin, R.J. and S.R. Ash. "First Early Mesozoic Amber in the Western Hemisphere." *Geology* 19 (1991): 273-276.
- Raphael, Toby. *Exhibit Conservation Guidelines* (CD-ROM publication). Harpers Ferry, WV: National Park Service, Harpers Ferry Center, 1999.
- Seymour, K. "Computerized Specimen and Preparation/Conservation Worksheets for Fossil Vertebrates." *Collection Forum* 4, no. 2 (1988).
- Shelton, S.Y., R. C. Barnett, and M. D. Magruder. "Conservation of a Dinosaur Trackway Exhibit." *Collection Forum* 9, no. 1 (1993).
- Tétreault, Jean. *Guidelines for Selecting Materials for Exhibit, Storage and Transportation*. Ottawa: Canadian Conservation Institute, 1993. Available on the Web at: http://www.cci-icc.gc.ca/document-manager/view-document_e.cfm?Document_ID=82&ref=co.
- _____. *Display Materials: The Good, the Bad, and the Ugly*. Ottawa: Canadian Conservation Institute, 1994. Available on the Web at: http://www.cci-icc.gc.ca/document-manager/view-document_e.cfm?Document_ID=83&ref=co.

- _____. Coatings for Display and Storage in Museums. CCI Technical Bulletin No. 21. Ottawa: Canadian Conservation Institute, 1999.
- _____. Oak Display Cases: Conservation Problems and Solutions. Ottawa: Canadian Conservation Institute, 1999. Available on the Web at: http://www.cci-icc.gc.ca/document-manager/view-document_e.cfm?Document_ID=80&ref=co.
- _____. Airborne Pollutants in Museums, Galleries and Archives: Risk Assessment, Control Strategies and Preservation Management. Ottawa: Canadian Conservation Institute, 2004.
- Thrush, P. W. (ed.). A Dictionary of Mining, Mineral and Related Terms. Washington, D.C.: United States Department of the Interior, Bureau of Mines, 1968.
- Waddington, J. and J. Fenn. "Preventive Conservation of Amber: Some Preliminary Investigations." Collection Forum 4, no. 2 (1988).
- Waller R., K. Andrew, and J. Tétreault. "Survey of Gaseous Pollutant Concentration Distributions in Mineral Collections." Collection Forum 14, nos. 1-2 (2000).

**National Park Service
Paleontological Specimens
Preparation/Conservation Record**

Catalog Number JODA 8499
DF8001

Accession Number 248

Field Number

Taxon: *Stylemys* Sp.

Description: Cranium and shell fragments

1. Permanent Location: Collection Storage, Cabinet 56, Drawer 3
2. Field Observations: when collected it was not recognized as a turtle skull immediately because it was in about 13 pieces and caked with loose sediment.
3. Condition on Receipt: In several pieces and in need of a good wash to reveal the broken surfaces.
4. Development Notes: Prep by Matt Smith

2000

- | | | |
|-----------------------|------------|---|
| 11 th Sept | 15 min | Started exploring the matrix on the occipital portion of the cranium, removing loose bits and probing and cleaning obvious foramina. Vinac |
| 12 th Sept | 7 hours | Continued with occipital portion of cranium. Cleaned out right otic capsule. Portion that I had attached before with a drop of vinac loosened and dropped off I cleaned both surfaces and reattached. Removed matrix from ventral surfaces and the right quadrate. The posterior portion of the skull has suffered some wear and tear pre-burial. The occipital condyl is missing as is bone from the area just behind the right otic capsule. The squamate bone I believe? Also the posterior portions of the parietals and supraoccipital. Just started work on the left post-orbital, jugal, and quadratojugal (poj) portion of the skull. Vinac |
| 13 th Sept | 5 hours | Worked mainly on poj today. Started by cleaning off as much of the exterior surface as possible to ascertain if the fractures would allow me to clean out the interior surfaces or just what. Also worked on left otic capsule and discovered that even more of the squamatic bone is missing on this side. Also, it appears that the articular surface of the quadrate has been damaged. The fracturing of the qj is quite extensive and I don't believe it will allow me to clean out the interior surfaces as I had hoped. Vinac |
| 14 th Sept | 5:45 hours | Continued cleaning out the left otic capsule today and discovered the stapes is present and intact!! Also the large mass of matrix on the dorsal surface of the prootic and the opisthotic was easily removed revealing the suture where the squamosal would have been. The whole area was easily freed of matrix leaving the posterior portion largely exposed. I have decided to limit the amount of matrix in |

		the left postorbital area by confining it to a series of arches to provide strength. There are also impressions of missing bone on these arches that I thought may be worth preserving. Worked a bit on the right orbit. Vinac
15th Sept	7:15	Continued on the right orbit and external surface of the fore part of the skull. I made a supportive jacket for the edge of the maxilla and premaxilla and started to expose the knife like edge of these bones. This was done mainly with a pin-vise to avoid damage. I then started to work down onto the premaxilla at the end of the day. Vinac
16th Sept	2 hours	Worked on premaxillae and maxillae. Vinac.
18th Sept	4:15 hours	Continued on palate working backwards exposing crenellations on maxillae. Injected thick vinac into break in left maxilla. This should hold it if I am careful enough. The matrix is hard and then becomes strangely soft about 1/8 to 1/16 of an inch away from the bone. Vinac.
19th Sept	3:45 hours	Continuing on palate. I am now starting to dip into the internal nares and vomerine area. Exposed an area on the posterior most portion of maxilla or perhaps the pterygoid. It was an extremely thin lip of bone and wanted to shatter. I had to preserve it with paleobond because the vinac was too soft and would soften every time I applied more vinac or 'washed the fossil with acetone. The vomer seems to form a knife like ridge that extends all the way back to the pterygoids from the premaxilla area.
20th Sept	2:45 hours	I have removed the supportive jacket because the danger to the maxillae is over and I need more mobility to reach the areas around the vomer and the orbits. I removed the matrix all along the vomer with a needle and the thing is a amazingly thin ridge of bone over most of its length. I have started to try and work behind the jugal and post orbital of the right orbit and clean that area out entirely. It seems stable enough to do this. Vinac.
21st Sept	5 hours	Worked on right orbital and post orbital areas. It has been exceedingly difficult because of the angles involved in getting under the cheekbones. Also the huge foramen in-between the eyes was a challenge be cause of the ridges of bone along the ventral surface. The anterior portion of one of these ridges began to shatter an I stabilized it with paleobond. Also there is a slight wing of bone that I had to leave some matrix on in the posterior portion of the temporal area. This wing broke off and I reattached it with paleobond. It is too fine and the matrix is too well adhered to attempt to remove it. the corresponding area on the posterior portion of the cranium is broken away and so it looks like it is just hanging out in space but in reality that would not have been the case. Washed the shell fragments and tried to look for further skull fits but found none. Vinac.
22nd Sept	1:40 hours	Did some final picking and probing. Tried to remove as much of the dirt and such as possible that was caked on by too much vinac. Then I tacked it all together in order to store it. I also tacked together two portions of the shell that fitted together. By 'tacked' I mean a drop of thick vinac here and there that will easily come apart with the application of acetone.

Figure U.5. Example Preparation Record #1 (continued)

**Preparation/Conservation Record
National Park Service
Hagerman Fossil Beds NM
Paleontological Specimens**

Catalog #: _____ **Accession #:** _____ **Field #:** _____

Preparator's Name: _____ **Date to begin work:** _____

Specimen (Family, Genus, Species): _____

Element: _____

Permanent Location: _____

Field Observations: _____

Condition Upon Receipt: _____

Development Notes: _____

Consolidants: _____ B15 _____ B72 _____ PVA _____ Glyptal _____ B76

_____ B98 _____ PaleoBond Other: _____

Adhesives: _____ B76 _____ B98 _____ B15 _____ DUCO _____ PVA

_____ Cyanoacrylate _____ PaleoBond Other: _____

Stabilizers and Fillers: _____ Plaster _____ Carbowax _____ Plastic

_____ Mache Other: _____

Casting/Molding Notes: _____

Attachments (photos, drawings, etc): _____

Comments: _____

Date Complete: _____ **Total Hours (see reverse side):** _____

Figure U.6. Example Preparation Record #2 (continued)

MUSEUM HANDBOOK



PART II MUSEUM RECORDS

ACKNOWLEDGEMENTS

The NPS *Museum Handbook*, Part II, is coordinated by the Information Management Team (IMT), Museum Management Program (MMP), National Center for Cultural Resources. IMT member, Kathleen Byrne, was responsible for coordinating the revision. Several MMP staff contributed to the writing, technical review, and layout of this handbook.

Museum Handbook, Part II authors are:

Chapters 1-6: Kathleen Byrne, Museum Registrar

Appendix A: (1994) Tony Knapp, Staff Curator; revised by Steve Floray, Museum Specialist

Appendix B: Ann Hitchcock, Chief Curator; Lynn Black, Computer Specialist

Appendix D: Diane Vogt-O'Connor, Senior Archivist

All other appendices were revised by Kathleen Byrne with assistance from Kandace Muller, Museum Technician, and interns Barbara Copp, Jason O'Neal, and Jennifer Walton.

Thanks to the Department of the Interior Office of the Solicitor for legal review; the American Association of Museums for review and advice on Chapter 6, Deaccessioning; Joan Bacharach, Museum Registrar, for her work on the 1984 version of the handbook and subsequent revisions; Ann Hitchcock, Chief Curator, for her critical review of the text; and especially Carolyn Moler, Administrative Assistant, for the many hours devoted to formatting and layout of the text and forms.

TABLE OF CONTENTS

	<u>Page</u>
INTRODUCTION	ix
1. DOCUMENTING MUSEUM COLLECTIONS	
A. Overview.....	1:1
B. Training.....	1:3
C. Work Area	1:3
D. Forms, Supplies, and Equipment	1:4
E. Authorities.....	1:7
F. Records Protection.....	1:8
G. Information Protection.....	1:11
H. List of Figures	1:11
2. ACCESSIONING	
A. Overview.....	2:1
B. General Information on Accessions.....	2:1
C. Acquisition Policies.....	2:4
D. Special Considerations for Accessions	2:5
E. Acquiring Copyrights	2:7
F. Gifts	2:8
G. Gift Considerations.....	2:10
H. Purchases	2:13
I. Purchase Considerations.....	2:14
J. Exchanges.....	2:17
K. Exchange Considerations	2:18
L. Transfers	2:20
M. Transfer Considerations.....	2:21
N. Field Collections	2:22
O. Other Field Collections	2:25
P. Incoming Loans.....	2:27
Q. Incoming Loan Considerations	2:28
R. Processing and Documenting Incoming Loans.....	2:30
S. Tracking Incoming Loans.....	2:33
T. Old Loans	2:35
U. Accession Book.....	2:38
V. Documenting Accessions	2:43
W. List of Figures.....	2:51
3. CATALOGING	
A. Overview.....	3:1
B. General Information on Cataloging.....	3:2
C. Cataloging Procedures.....	3:6
D. Tracking Catalog Numbers	3:10
E. Cultural Resources (CR) Catalog Data Fields.....	3:12
F. Natural History (NH) Catalog Data Fields.....	3:16
G. Making Changes on the Catalog Record	3:18
H. Submitting Catalog Records to the National Catalog.....	3:20
I. List of Figures.....	3:24

4. INVENTORY AND OTHER SPECIAL INSTRUCTIONS	
Section I. Annual Inventory of Museum Property	4:1
A. Overview	4:1
B. Conducting the Inventory	4:4
C. Completing the Random Sample and Controlled Property Inventories	4:7
D. Accessions Inventory	4:8
E. Completing the Accessions Inventory	4:9
F. Submitting the Inventory	4:10
G. Inventory Deficiencies and Property Irregularities	4:11
H. Spot-Check Inventories and Audits	4:12
Section II. Documenting Object Location	4:12
A. Overview	4:12
B. Documenting Current Location	4:13
C. Documenting Location Changes	4:13
Section III. Reporting Loss of Museum Objects	4:14
A. Overview	4:14
B. Discovering Loss	4:15
C. Reporting Loss	4:16
Section IV.. Reproductions, Living History Items, Exhibition Aids, and Outdoor Exhibits	4:19
A. Reproductions	4:19
B. Living History Items	4:21
C. Exhibition Aids	4:22
D. Outdoor Exhibits	4:22
Section V. Consumptive Use of Museum Objects	4:23
A. Overview	4:23
B. Consumptive Use Approval	4:23
Section VI. Following Regulations for Cataloging Natural History Specimens	4:24
A. Overview	4:24
B. Documenting Natural History Collections Collected under 36 CFR 2.5g	4:25
C. Natural History Collections on Loan to Non-NPS Repositories	4:29
Section VII. Buying Insurance for Borrowed Objects	4:29
A. Overview	4:29
B. Buying Insurance	4:30
C. Insurance Policies	4:31
Section VIII. Completing the Collections Management Report	4:34
A. Overview	4:34
B. Reporting Center Collections	4:35
C. CMR Program	4:36
D. Completing the CMR	4:37
E. Submitting the CMR	4:41
Section IX. Determining the Monetary Value of Museum Objects	4:42
A. Overview	4:42
B. Monetary Values	4:43
C. Assigning Monetary Value	4:43
D. Professional Appraisals	4:45
E. Re-Appraising Objects	4:49
F. Documenting Appraisal Information	4:49
G. Appraisals and Tax Deductions	4:49

Section X. List of Figures	4:50
5. Outgoing Loans	
A. Overview.....	5:1
B. General Information on Loans	5:1
C. Outgoing Loan Considerations	5:3
D. Documenting Loans	5:6
E. Processing Loans.....	5:10
F. Tracking Loans.....	5:11
G. Special Procedures for Lending Objects to Repositories.....	5:13
H. Special Procedures for Lending Objects to NPS Conservation Treatment Facilities.....	5:14
I. List of Figures.....	5:15
6. Deaccessioning	
A. Overview.....	6:1
B. General Information on Deaccessions	6:1
C. Special Considerations for Deaccessions	6:3
D. Processing Deaccessions.....	6:7
E. Documenting Deaccessions	6:10
F. Tracking Deaccessions.....	6:15
G. Packing and Shipping Deaccessions	6:17
H. Return to Rightful Owner (See Flow Chart Figure 6.1)	6:18
I. Loss, Theft, Involuntary Destruction, Voluntary Destruction/Abandonment (See Flow Chart Figure 6.2).....	6:19
J. Outside Scope of Collection (See Flow Charts Figures 6.3 and 6.4)	6:22
K. Outside SOCS Requirements.....	6:25
L. Outside SOCS Procedures.....	6:28
M. Destructive Analysis	6:32
N. Native American Graves Protection and Repatriation Act (See Flow Chart Figure 6.5)	6:32
O. NPS Clearinghouse Services.....	6:37
P. List of Figures.....	6:38

APPENDICES

	<u>Page</u>
A. MANDATES AND STANDARDS FOR NPS MUSEUM COLLECTIONS	
A. Overview.....	A:1
B. Laws, Regulations, and Conventions – NPS Cultural Collections	A:1
C. Laws, Regulations, and Conventions – NPS Natural History Collections.....	A:6
D. Policies and Standards	A:9
E. List of Figures.....	A:17
B. CATALOGING COSTS	
A. Estimating Cataloging Costs.....	B:1
B. Funding Cataloging Costs.....	B:2
C. Applying For and Spending Cataloging Funds	B:3
D. List of Figures.....	B:5
C. CATALOGING GUIDELINES	
A. Overview.....	C:1
B. Component Parts, Pairs, and Sets	C:1
C. Methods of Describing Objects.....	C:3
D. Terms for Describing Object Condition	C:4
E. Measuring Objects	C:8
F. Recording Dimensions and Weight.....	C:11
D. MUSEUM ARCHIVES AND MANUSCRIPT COLLECTIONS	
A. Overview.....	D:1
B. Understanding Definitions	D:5
C. Reviewing the Basics of Park Records Management	D:7
D. Learning Archival Theory.....	D:9
E. Locating and Identifying Park Archival and Manuscript Collections	D:11
F. Summarizing Survey Findings.....	D:16
G. Appraising and Evaluating Collections	D:17
H. Accessioning Collections	D:19
I. Preserving Collections	D:20
J. Arranging Collections.....	D:23
K. Creating Folder Lists	D:23
L. Creating and Updating Other Container Lists.....	D:26
M. Writing Finding Aids.....	D:27
N. Determining How to Catalog Your Archival and Manuscript Collections	D:28
O. Cataloging Archival and Manuscript Collections: ANCS+ Collections Management Module....	D:29
P. Cataloging Archival and Manuscript Collections: ANCS+ Archives Module.....	D:31
Q. Planning for the Future	D:32
R. Producing Repository-level Guides to Park Holdings.....	D:37
S. Publicizing the Finding Aid or Repository-level Guide	D:38
T. Providing Access to Archival and Manuscript Collections	D:39
U. Identifying Appropriate Restrictions for Archival and Manuscript Collections.....	D:41
V. Implementing Access and Usage Policies for Archival and Manuscript Collections	D:47
W. Monitoring and Tracking Researcher Use of Archival and Manuscript Collections.....	D:48
X. Handling Freedom of Information Act Requests	D:51
Y. Documenting Copies	D:54
Z. Understanding the Language: A Glossary.....	D:56
AA. Identifying Further Sources of Archival Training and Guidance	D:62
BB. Readings: A Bibliography	D:63
CC. List of Figures	D:71

E. ARCHEOLOGY	
A. Archeology Classification.....	E:1
B. Archeology Object Names.....	E:4
C. Cataloging Archeology.....	E:5
D. Within Site Provenience Abbreviations.....	E:6
E. Archeology Object Name List.....	E:8
F. ETHNOLOGY	
A. Ethnology Classification.....	F:1
B. Ethnology Object Names.....	F:5
C. Cataloging Ethnology.....	F:6
D. Cultural Area and Cultural Group Classification.....	F:6
G. HISTORY	
A. History Classification.....	G:1
B. History Object Names.....	G:2
C. Cataloging History.....	G:6
D. Revised Nomenclature Hierarchical Classification.....	G:6
E. Supplementary History Object Term List.....	G:8
H. NATURAL HISTORY (To be revised and reissued in 2001.)	
I. LOT CATALOGING	
A. General Rules for Lot Cataloging.....	I:1
B. Discipline-specific Rules for Lot Cataloging Cultural Resources Collections.....	I:2
C. Discipline-specific Rules for Lot Cataloging Natural History Collections.....	I:4
D. List of Figures.....	I:8
J. MARKING	
A. Marking Guidelines.....	J:1
B. Applying and Removing Numbers.....	J:3
C. Marking Human Remains.....	J:5
D. Marking Paper Items.....	J:6
E. Plastics, Vinyl, and Rubber.....	J:7
F. Marking Textiles.....	J:8
G. Large and Small Objects and Unstable Surfaces.....	J:10
H. Leather and Baskets.....	J:11
I. Numbering Component Parts, Pairs, and Sets.....	J:12
J. Number Location for Specific Types of Objects.....	J:12
K. Natural History Specimens.....	J:15
K. PHOTOGRAPHY	
A. Museum Record Photography.....	K:1
B. Equipment.....	K:2
C. Procedures.....	K:5
D. Processing the Film.....	K:13
E. Documentation and Storage.....	K:14
F. List of Figures.....	K:16
L. BIBLIOGRAPHY	
Archeology.....	L:1
Ethnology.....	L:8
History.....	L:10
Catalogs and General Reference.....	L:45
Museum References.....	L:46
Appraisals.....	L:46

LIST OF FIGURES

Figure Number	Caption	Page
1.1	NPS Forms in ANCS+	1:12
2.1	Receipt for Property (Form DI-105).....	2:52
2.2a-b	Accession Receiving Report (Form 10-95 Rev.)	2:53
2.3	Deed of Gift (Form 10-830 Rev.).....	2:55
2.4	Letter of Acknowledgment (Sample)	2:56
2.5	Gift Acknowledgment Certificate	2:57
2.6	Ownership Statement (Sample)	2:58
2.7	Transfer of Copyright Statement (Sample).....	2:59
2.8a-b	Exchange Agreement (Sample)	2:60
2.9	Transfer of Property (DI-104)	2:62
2.10	Instructions for Completing and Sending the Incoming Loan Agreement	2:63
2.11a-b	Incoming Loan Agreement (Form 10-98 Rev.).....	2:64
2.12	Conditions for Incoming Loans (Form 10-98a Rev.)	2:66
2.13	Flow Chart for Incoming Loans.....	2:67
2.14	List of Objects (Form 10-417).....	2:68
2.15	State Old Loan Law Citations	2:69
2.16	Accession Book (Form 10-256) (Sample)	2:70
2.17	Flow Chart for Accessioning	2:71
2.18	Accession Folder Cover Sheet (Form 10-255).....	2:72
2.19	Source of Accession Card (Sample)	2:73
3.1	Museum Catalog Record – CR, Form 10-254 Rev.	3:25
3.2	Museum Catalog Record – NH, Form 10-254B Rev.	3:26
3.3	Catalog Number Logbook Page (Sample)	3:27
3.4	Archeology Catalog Record (Sample)	3:28
3.5	Ethnology Catalog Record (Sample)	3:29
3.6	History Catalog Record (Sample).....	3:30
3.7	Archival/Manuscript Catalog Record (Sample).....	3:31
3.8	Biology Catalog Record (Sample)	3:32
3.9	Geology Catalog Record (Sample).....	3:33
3.10	Paleontology Catalog Record (Sample)	3:34
3.11	Cultural Resources Classification	3:35
3.12	Natural History Classification.....	3:36
3.13	Receipt for Property, DI-105 (Sample for National Catalog Submission).....	3:37
4.1a	Inventory of Museum Property, Random Sample (Form 10-349)	4:51
4.1b	Inventory of Museum Property, Random Sample Continued (Form 10-349A).....	4:52
4.1c	Inventory of Museum Property, Random Sample Summary (Form 10-349A).....	4:53
4.1d	AIP Summary for Random Sample Inventory [Optional]	4:54
4.2a	Inventory of Museum Property, Controlled Property (Form 10-349)	4:55
4.2b	Inventory of Museum Property, Controlled Property Continued (Form 10-349D)	4:56
4.2c	Inventory of Museum Property, Controlled Property Summary (Form 10-349D)	4:57
4.2d	AIP Summary for Controlled Property [Optional].....	4:58
4.3a	Inventory of Museum Property, Accessions (Form 10-349B).....	4:59
4.3b	Inventory of Museum Property, Accessions Continued (Form 10-349C)	4:60
4.3c	Inventory of Museum Property, Accessions Summary (Form 10-349C).....	4:61
4.3d	AIP Summary for Random Accessions Inventory [Optional]	4:62
4.4	Object Temporary Removal Slip (Form 10-97)	4:63
4.5	Report of Survey (DI-103).....	4:64
4.6	Collections Management Report (Form 10-94 Rev.).....	4:65
4.7	Written Appraisal Sample	4:66

Figure Number	Caption	Page
5.1	Flow Chart for Outgoing Loans.....	5:16
5.2	Instructions for Completing and Sending the Outgoing Loan Agreement	5:17
5.3a-b	Outgoing Loan Agreement (Form 10-127 Rev.).....	5:18
5.4a-b	Conditions for Outgoing Loans (Form 10-127a).....	5:20
5.5	List of Objects (Form 10-417) [Optional]	5:22
5.6	Object Condition Report (Form 10-637) [Optional].....	5:23
5.7	Outgoing Loan Folder Cover Sheet (Form 10-640) [Optional]	5:24
5.8	Outgoing Loan Extension (Form 10-641) [Optional].....	5:25
6.1	Flow Chart for Deaccessioning: Return to Rightful Owner	6:39
6.2	Flow Chart for Deaccessioning: Loss, Theft, Involuntary Destruction, and Voluntary Destruction/Abandonment	6:40
6.3	Flow Chart for Deaccessioning: Outside Scope of Collection Statement Transfer and Exchange	6:41
6.4	Flow Chart for Deaccessioning: Outside Scope of Collection Statement Conveyance (Donation) and Voluntary Destruction/Abandonment	6:42
6.5	Flow Chart for Deaccessioning: Native American Graves Protection and Repatriation Act.....	6:43
6.6	Deaccession Form (Form 10-643)	6:44
6.7	List of Objects (Form 10-417) [Optional]	6:45
6.8	Deaccession Folder Cover Sheet (Form 10-644) [Optional]	6:46
6.9	Deaccession Book (Form 10-642) [Optional]	6:47
6.10	Transfer of Property (DI-104)	6:48
6.11a-b	Exchange Agreement (Sample)	6:49
6.12a-b	Repatriation Agreement (Sample).....	6:51
6.13	Conveyance Agreement (Form 10-99).....	6:53
6.14	Collections Advisory Committee Procedures (Sample).....	6:54
6.15	Specialist Review Form (Sample)	6:55
A.1	Museum Properties Act of 1955 as amended November 12, 1996.....	A:18
A.2	References to Museum Collections Management in IPMR.....	A:19
A.3	Director's Order #24: NPS Museum Collections Management	A:21
B.1a	Recent Cataloging Costs (FY 1997).....	B:5
B.1b	Recent Cataloging Costs (FY 1998).....	B:6
B.1c	Recent Cataloging Costs (FY 1999).....	B:7
D.1	Sequential Overview of Park Archival Work.....	D:72
D.2	Documentary Records Types Chart (Cultural Resource Management Guideline Release No. 5).....	D:73
D.3a	Archival and Manuscript Collections Survey Form (Sample) [Optional]	D:74
D.3b	Completed Archival and Manuscript Collections Survey Form (Sample) [Optional]	D:75
D.4	Sample Collection-Level Survey Description	D:76
D.5a	Separation Sheet (Form 10-645) [Optional]	D:77
D.5b	Completed Separation Sheet (Form 10-645) [Optional]	D:78
D.6a	Folder List-Archival and Manuscript Collections (Form 10-96 Rev.) (Sample) [Optional]	D:79
D.6b-c	Example of a Completed Folder List	D:80
D.7a-b	Sample Folder List Index	D:82
D.8	Sample Container List	D:83
D.9a	Museum Catalog Record-Cultural Resources (Form 10-254 Rev.)	D:84
D.9b	Completed Museum Catalog Record (Form 10-254 Rev.) for Personal Papers	D:85
D.9c	Completed Museum Catalog Record (Form 10-254 Rev.) for Field Records	D:86
D.9d	Completed Museum Catalog Record (Form 10-254 Rev.) for Park Project Photograph Collection	D:87

Figure**Number Caption****Page**

D.10	Park Archival Processing Plan Statement (Sample)	D:88
D.11	Park Documentation Strategy Statement (Sample)	D:88
D.12	Shelf List (Sample) [Optional]	D:89
D.13a-b	Access Policies and Rules Governing Use (Sample) [Optional]	D:90
D.14	Researcher Duplication Form (Sample) [Optional]	D:92
D.15	Copyright and Privacy Restrictions (Sample) [Optional]	D:93
D.16	Researcher Registration Form (Sample) [Optional]	D:94
I.1	Completed Catalog Record – Lot Cataloging (Archeology).....	I:9
I.2	Completed Catalog Record – Lot Cataloging (Archeology).....	I:10
I.3	Completed Catalog Record – Lot Cataloging (History)	I:11
I.4	Completed Catalog Record – Lot Cataloging (Biology)	I:12
I.5	Completed Catalog Record – Lot Cataloging (Geology)	I:13
K.1	Kodak Gray Card Instructions	K:17
K.2	Placement of Object	K:6
K.3	Placement of Identification Information and Metric Scale	K:7
K.4	Basic Lighting Setup	K:8
K.5	Distance and Angles for Light Placement.....	K:8
K.6	Height of Light.....	K:8
K.7	Angles for Key and Fill Lights	K:9
K.8	Relationship of Shadows from Key and Fill Lights.....	K:10
K.9	Composing the Photograph: Distance.....	K:10
K.10	Composing the Photograph: Camera Angle.....	K:10
K.11	Choosing Vertical or Horizontal Format.....	K:11
K.12a	Object Photograph Record Sheet.....	K:18
K.12b	Object Photograph Record Sheet (Sample).....	K:19
K.13	Labelling for Photo Enclosures (Sample)	K:20

INTRODUCTION

The *Museum Handbook* covers a broad range of topics to guide National Park Service staff in managing museum and archival collections:

- Part I covers planning, preservation, and protection for the disciplines and materials represented in NPS collections, including professional ethics, specialized storage, environment standards, conservation treatments, and emergency preparedness.
- Part II outlines procedures for museum record keeping, including accessioning, cataloging, loans deaccessioning, photography, and reporting annual collection management data.
- Part III provides guidance on access and use for interpretation, education, exhibition, and research. It covers legal issues, publications, two and three-dimensional reproductions, using museum objects in exhibits and furnished historic structures, and providing access for research.

NPS staff responsible for collections should make informed choices based on their own skills and experience, standards and procedures outlined in the *Museum Handbook*, advice provided by specialists, and additional information provided in the references found in the *Museum Handbook*. Staff should, as needed, seek advice or technical information from support offices, the Harpers Ferry Center, and the Museum Management Program, National Center for Cultural Resources.

By following the practices represented in this guidance, trained staff can ensure that the National Park Service collections will be, as mandated by the 1916 NPS Organic Act, preserved and maintained for the use and enjoyment of the present and future generations.

Ann Hitchcock
Chief Curator
Museum Management Program
National Center for Cultural Resources
September 2000

Chapter 1: Documenting Museum Collections

	<u>Page</u>
A. Overview	1:1
What will I find in this handbook?	1:1
How is this handbook different from the <i>ANCS+ User Manual</i> ?	1:1
What is ANCS+?	1:1
Where can I get ANCS+?	1:2
What is the purpose for museum records?	1:2
Who must follow the guidelines in this handbook?	1:2
Am I required to follow this handbook?	1:2
What do I do if I know little about museum management?	1:2
What is in this chapter?	1:2
B. Training	1:3
Where can I get training in museum documentation methods?	1:3
Where can I get training in NPS museum documentation methods?	1:3
What if I can't find a training course?	1:3
C. Work Area	1:3
Do I need a special work area for museum record keeping?	1:3
Are there special requirements for the work area?	1:4
What should I consider when setting up the work area?	1:4
D. Forms, Supplies, and Equipment	1:4
Where do I get NPS museum forms?	1:4
Must I use the forms in ANCS+?	1:5
What forms aren't available in ANCS+?	1:5
What supplies do I need for museum record keeping?	1:5
Where do I get museum record keeping supplies?	1:6
What types of equipment do I need for museum record keeping?	1:7
Where do I get equipment?	1:7
E. Authorities	1:7
Who is responsible for the museum records at a park?	1:7
What are the superintendent's duties as the accountable officer for museum records?	1:7
What forms must the superintendent sign?	1:8
What are the custodial officer's responsibilities for museum records?	1:8
What are the receiving officer's responsibilities for museum records?	1:8
F. Records Protection	1:8
How can I protect my museum records against deterioration and destruction?	1:8
What are the requirements for storing paper museum records?	1:9
What types of storage equipment are available?	1:9
Where can I get storage equipment for my museum records?	1:10
What if I have a very large amount of records?	1:10
What are the requirements for storing media?	1:10
What are the differences between a media safe, a mixed media file, and a media box?	1:10
Are there requirements for the room where I store museum records?	1:11
G. Information Protection	1:11
Can the NPS protect sensitive or confidential information that the park has acquired as part of documentation activities?	1:11
Where can I find more information about protecting sensitive or confidential information?	1:11
H. List of Figures	1:11

CHAPTER 1: DOCUMENTING MUSEUM COLLECTIONS

A. Overview

1. *What will I find in this handbook?* The *Museum Handbook*, Part II, Museum Records, tells you about the records you need to manage National Park Service (NPS) museum collections. These records are consistent with professional standards. Use the handbook as a reference. Refer to it when you:

- accession material into the museum collection (Chapter 2)
- receive incoming loans (Chapter 2)
- catalog objects (Chapter 3)
- photograph objects (Appendix K)
- mark objects with a catalog number (Appendix J)
- report losses of museum objects (Chapter 4)
- conduct the annual inventory of museum property (Chapter 4)
- complete the annual Collections Management Report (Chapter 4)
- place museum collections on outgoing loan (Chapter 5)
- deaccession museum collections (Chapter 6)

Note: The *Museum Handbook*, Part I: Museum Collections (*MH-I*), tells you how to physically care for your collections. The *Museum Handbook*, Part III: Museum Collections Use (*MH-III*), gives you information on providing access to and using your collection.

2. *How is this handbook different from the ANCS+ User Manual?* This handbook gives you the guidelines for carrying out NPS museum policies on museum records.

The *ANCS+ User Manual* gives you detailed instructions on how to use the ANCS+ collection management system. ANCS+ allows you to automate the procedures in this handbook.

3. *What is ANCS+?* ANCS+ is the NPS collections management system that allows you to automate all your museum records. It is a customized, commercial program from Re:discovery Software, Inc. You must use ANCS+ to:

- accession and catalog your collection
- complete the annual inventory and Collections Management Report
- document incoming and outgoing loans and deaccessions

4. *Where can I get ANCS+?* You must order ANCS+ through the Museum Management Program (MMP), WASO. In 1998 most parks received an appropriated increase of \$3,000 to their budgets to purchase and support the program. If you are a new park, you may not have this increase in your budget.
- Refer to Appendix H in the *ANCS+ User Manual* for information on ordering the program.
5. *What is the purpose for museum records?* Museum records allow you to properly care for and access your collection. You need records to prove ownership, describe the material in the collection, document loans, and locate objects. Museum records insure that museum collections are physically and intellectually available for collections management, interpretation, exhibition, and research. They give you accountability for your collection.
6. *Who must follow the guidelines in this handbook?* The person responsible for the park's museum collection must follow the guidelines and procedures in this handbook. These guidelines and procedures insure that the park's museum records meet NPS standards.
- Note:** Office of Personnel Management (OPM) Personnel Classification Standards require that a GS-11 (or higher) level curator must oversee each park's museum collection. The regional/support office (SO) curator can provide oversight for parks with small collections. The curator provides professional guidance and oversees all documentation work at the park. Equivalent occupation series positions, such as archivist or museum specialist, may serve in this position. Refer to *MH-I*, Chapter 12: Curatorial Programming, Funding, and Staffing for information on staffing for museum collections.
7. *Am I required to follow this handbook?* Yes. You must follow this handbook to accession, catalog, loan, inventory, and deaccession museum collections. You must use NPS forms to document these actions.
8. *What do I do if I know little about museum management?* Start by reading the Basic Requirements page at the beginning of each chapter. These one-page summaries tell you the basics on what you must do.
- Read the section in this chapter on how to get training in museum records and ANCS+.

Refer to the appropriate chapter or appendix in this handbook for detailed instructions before beginning to do the work.

Don't be afraid to ask for help. Contact your regional/SO curator or other curators in the area with questions. Make sure your park and region know that you lack experience and are interested in getting training.

9. *What is in this chapter?* This chapter will help you get started with museum record keeping. It includes sections on:
- museum records training
 - preparing a work area
 - forms and supplies

- delegation of authority for museum collections
- records protection

B. Training

1. *Where can I get training in museum documentation methods?*

A number of museums, museum organizations, and academic institutions offer excellent short courses in museum record keeping. These courses can give you an understanding of the basic principles of museum records that are common to all museums. However, each museum has its own system for documenting collections. To learn the NPS procedures for museum records, you must take a training class on documenting NPS collections.

2. *Where can I get training in NPS museum documentation methods?*

See the NPS Employee Training and Development Career Planning and Tracking Kit for your essential competencies, which are the skills you need to do your job. Review your KSAs (Knowledge, Skills, and Abilities) under your essential competency “Research and Inventory” and discuss your training needs with your first-line supervisor. Prepare an Individual Development Plan (IDP) that addresses your training needs. You can access the tracking kit at “The Learning Place” web site under the Park Net Home Page at www.nps.gov/training/npsonly/npscom.htm.

Some regions offer specific training courses on documentation and the use of ANCS+. There are also regional training courses on basic curatorial work that include sessions on museum records.

Contact your Regional Employee Development Officer (EDO) or the Training Manager, Cultural Resources Stewardship Career Field, at Stephen T. Mather Training Center, for information on available courses. You may be able to take a course in another region if your region is not offering training.

Note: Refer to Appendix L in this handbook for a bibliography of some of the standard texts on museum records.

3. *What if I can't find a training course?*

One of the best ways to learn about museum records is to get a temporary detail to another park or NPS center. Make sure the park has an active museum program and an experienced curatorial staff. You can gain valuable experience by working with park or center curators who can supervise and review your work. Your regional/SO curator may be able to help you coordinate a detail or locate a cooperating park.

Some regions may send curatorial staff from another park or NPS center to give you hands-on training at your site. Contact your regional/SO curator to find out if someone is available in your region.

C. Work Area

1. *Do I need a special work area for museum record keeping?*

Yes. You need to set up an adequate, secure work area that is separate from the collections storage area. It should contain space for all the museum files, such as the accession file, and your ANCS+ computer. You must keep all museum files in a locked, insulated file cabinet. Refer to Section F in this chapter for information about insulated files.

2. *Are there special requirements for the work area?*

Yes. There are several requirements for the area:

- Post a written warning against smoking, eating, and drinking in the area.
- Don't keep food, live plants, or flowers in the area.
- Keep the area clean and neat with nothing cluttering work surfaces, walkways, and aisles.
- Only issue keys to the area to the employees who have direct responsibility for the collections.
- Keep a current location map of all exhibit and storage areas. Include the letters and numbers of rooms, exhibit cases, and storage equipment, such as cabinets and shelf units.

3. *What should I consider when setting up the work area?*

When setting up the work area, consider the activities you'll be doing there, such as:

- receiving and unpacking objects
- examining objects for accessioning and cataloging
- measuring and weighing objects
- marking catalog numbers on objects
- photography
- entering data into ANCS+ and printing forms

A large padded table, or other flat surface, will be adequate for most objects. You may also need additional tables or shelves to hold items waiting to be accessioned or processed for loan. Organize your equipment, files, and supplies so that you can quickly find the things you frequently use.

Note: You should isolate objects coming into the collection for the first time to make sure they are pest free. Refer to the *MH-I*, Chapter 5, Biological Infestations, for additional information.

D. Forms, Supplies, and Equipment

1. *Where do I get NPS museum forms?*

Official NPS forms begin with "10-". You can print all official NPS museum forms from ANCS+. The program will complete many of the forms for you from data you enter on the screens. It also allows you to print blank forms that you can type or complete by hand. Use archival paper for printing official forms.

Refer to Figure 1.1 for a list of the forms in ANCS+. The list tells you which forms you can complete using ANCS+. The forms that relate to the chapters in this handbook appear at the end of each chapter.

Order accession books, deaccession books, and gift acknowledgement certificates from the Supply and Equipment Program of the Museum Management Program. See the Tools of the Trade catalog.

Note: You can order natural history labels from the Supply and Equipment Program while supplies last. You can also print the labels from ANCS+.

2. *Must I use the forms in ANCS+?*

Yes. You must use the **official** NPS museum forms in ANCS+ (forms numbered 10-). Don't modify these forms or create park-specific replacements. These forms meet legal requirements and professional standards. They also provide consistency between sites.

Some forms in ANCS+, such as the Repatriation Agreement, are Word documents that allow you to customize the form. These forms are sample forms for your use.

3. *What forms aren't available in ANCS+?*

ANCS+ doesn't have:

- forms for purchasing museum collections, such as the DI-1 Requisition
- forms for documenting loss of collections, such as the Case Incident Record, Form 10-343, or equivalent, and Report of Survey, Form DI-103
- Scientific Research and Collecting Permit

4. *What supplies do I need for museum record keeping?*

The supplies you need include:

- archival paper (for printing forms)
- pigma pen
- crochet hook
- tweezers (stamp handling variety)
- measuring rule (metric and SAE)
- cloth and metal tape measures (metric and SAE)
- white cotton gloves
- magnifying glass or linen tester
- caliper
- magnet (for testing metal objects)
- metric conversion table

Supplies for marking catalog numbers on objects include:

- technical pen (Rapidograph®) or crowquill pen
- clear lacquer (acrylic resin/acetone)
- white lacquer (acrylic resin/acetone with titanium dioxide white pigment)
- permanent black ink (Higgins®, Black Magic®, or Pelikan 17 Black)
- #2H, HB or softer pencil
- artist brushes (small tip)
- textile marking tape
- sewing needles and thread

Refer to Appendix J in this handbook for information on marking objects.

Supplies for record photography include:

- photo identification stands
- magnetic letters and numbers
- metric scale
- roll labels
- magnetic tape

Refer to Appendix K in this handbook for information on photographing objects.

5. *Where do I get museum record keeping supplies?*

Refer to the NPS *Tools of the Trade* catalog:

- Section II, Record Keeping Supplies, for additional information on supplies
- Section I, Introduction, for information on ordering supplies
- Section IX, Equipment and Supply Sources, for supply sources

The MMP publishes this catalog and updates it periodically. You can get some supplies free through the MMP's Supply and Equipment Program.

Depending on your collection, you may need additional supplies, such as weight scales and color charts. Contact other curators, conservators, and your regional/SO curator for other supply sources.

6. *What types of equipment do I need for museum record keeping?*

You must have:

- a computer capable of running ANCS+
- a printer for printing ANCS+ forms
- the ANCS+ software program
- insulated file cabinet(s) and media safe

If you photograph your collections, you will need a 35mm camera, a tripod, and lights. Many parks also use digital cameras to produce digital images for ANCS+.

7. *Where do I get equipment?*

The park pays for equipment. In FY 1998 parks received a recurring \$3,000 increase in base funding for the purchase and support of ANCS+. Your park receives this money every year for catalog-related costs. Use these funds to purchase your annual support and updates to ANCS+. If there is money left over, you may use it to fund cataloging or to purchase cataloging equipment, such as computers, printers, and digital cameras.

Refer to Appendix H, Support, in the *ANCS+ User Manual* for information on purchasing support. Refer to Appendix A, System Requirements, in the *ANCS+ User Manual* for information on the hardware you'll need for ANCS+.

Refer to the *Tools of the Trade* and Section F in this chapter for information on insulated file cabinets.

E. Authorities

1. *Who is responsible for the museum records at a park?*

NPS museum property is accountable property. The accountable officer for museum property is the superintendent or center manager. He or she has the overall responsibility for museum collections and museum records.

The custodial officer is directly accountable and responsible for the physical care and documentation of the museum collection. The custodial officer is the person in charge of the museum collection. At most parks this is the curator or collections manager.

The receiving officer is responsible for documenting the receipt of museum collections. The receiving officer can be one of the museum staff or a staff member from another division in the park.

Refer to the *Personal Property Management Handbook No. 44* for information on property officers.

2. *What are the superintendent's duties as the accountable officer for museum records?*

The superintendent has the authority to approve or disapprove all accessions, loans, and deaccessions.

The superintendent must sign all legal documents that transfer ownership (title) or custody of museum property.

The superintendent is also responsible for verifying and signing the annual inventory of museum property and the annual collections management report. Refer to Chapter 4 in this handbook for information about these reports.

The superintendent appoints, in writing, the custodial officer and the receiving officer for the museum collection.

3. *What forms must the superintendent sign?*

The superintendent must sign the following accession, loan, and deaccession forms. Refer to the chapters in parentheses for information about these forms.

- Deed of Gift, Form 10-830 (Chapter 2)
- Transfer of Property, Form DI-104 (Chapters 2 and 6)
- Exchange Agreement (Chapters 2 and 6)
- Incoming Loan Agreement, Form 10-98 (Chapter 2)
- Outgoing Loan Agreement, Form 10-127 (Chapter 5)
- Outgoing Loan Extension, Form 10-641 (Chapter 5)
- Deaccession Form, Form 10-643 (Chapter 6)
- Conveyance Agreement, Form 10-99 (Chapter 6)
- Repatriation Agreement (Chapter 6)

4. *What are the custodial officer's responsibilities for museum records?*

The custodial officer is in charge of museum records. The custodial officer recommends accessions, loans, and deaccessions to the superintendent and is responsible for justifying and documenting these transactions. He or she is responsible for accessioning and cataloging the collection, conducting the annual museum property inventory, and completing the collections management report. The custodial officer often supervises other staff who are doing the work.

5. *What are the receiving officer's responsibilities for museum records?*

The receiving officer signs the Accession Receiving Report, Form 10-95, the Receipt for Property, DI-105, and any other receipts for museum property. The custodial officer can't serve as the receiving officer.

F. Records Protection

1. *How can I protect my museum records against deterioration and destruction?*

Many of the common threats to museum collections are also threats to your museum records. It's important to take preventive actions against these threats because museum records are a valuable part of your collection.

Threat	Preventive Action
Human error	Training in proper techniques; checking work for accuracy
Fire	Insulated file; media file; good fire

prevention standards, fire detection devices, and suppression systems; Structural Fire Plan that includes the special needs of museum records

Theft	Locked file; secure storage with adequate key control and access; frequent inspection
Mildew/mold	Environmental monitoring; dehumidification if relative humidity exceeds 60%
Pests	Museum housekeeping program; frequent inspection; active Integrated Pest Management program; fumigation as necessary
Paper deterioration	Acid-free paper for museum forms
Water damage	Keep records away from pipes, basement, or flood plain
Disaster (earthquake, tornado, hurricane)	Emergency Operation Plan that includes the special needs of museum records; duplicate accession book and catalog records kept off-site
Electronic media deterioration	Backup copies (one copy off site); proper storage; media migration strategy

2. *What are the requirements for storing paper museum records?*

To protect museum records from fire and unauthorized use, store them in a locking, insulated file, safe, or vault. The interior of the container or vault must maintain a temperature of less than 350° F during a one-hour exposure to exterior temperatures of at least 1700° F.

3. *What types of storage equipment are available?*

Most parks use two, four, or five-drawer insulated (fire resistive) filing cabinets with combination or key locks. These are convenient to use and fairly inexpensive to purchase. The Underwriters Laboratories (UL) rating is “Insulated Filing Device, Class 350-1 Hour” (Formerly “UL Class D”).

Cabinets in spaces above the grade level of the building must be able to survive a drop through the floor during a fire. The UL rating is “Insulated Record Containers, Class 350-1 Hour” (Formerly “UL Class C”).

Impact resistant Class 350-2 hour and Class 350-4 hour filing cabinets are also available. Consider using one of these in buildings that are likely to burn long enough or hot enough to warrant the extra protection.

You can use one-door and two-door insulated safes to protect records that don't fit in a filing cabinet. The UL rating is “Fire-Resistive Safe, Class 350-4, 2, or 1-Hour”.

See *Tools of the Trade* and National Fire Protection Association (NFPA) 232, *Standard for the Protection of Records*, for information on records storage equipment.

4. *Where can I get storage equipment for my museum records?*

Section VI of the *Tools of the Trade* has information on fire-resistive filing cabinets and media safes. Sections IX and X have information on sources and current equipment contracts. The park pays for storage equipment. You can get money for museum records storage equipment through the Museum Collections Preservation and Protection Program (MCPPE).

Your regional/SO curator or MMP staff can give you information on storage equipment for museum records.

5. *What if I have a very large amount of records?*

For very large amounts of records, you may find it more cost-effective to use ordinary steel filing cabinets in a records vault. The vault construction must meet the requirements of the NFPA. See NFPA 232, *Standard for the Protection of Records*, for information on the construction of vaults. See NFPA 232AM, *Manual for the Protection of Archives and Records Centers*, for information on protecting large collections of paper records.

Vaults require doors with a UL rating, “Fire-Resistive Vault Door, Class 350-6, 4, or 2-Hour”. This type of door may have a combination lock or key lock. If less protection is acceptable, you can use a door with a UL rating, “Fire-Insulated File Room Doors, Class 350-1 Hour”.

6. *What are the requirements for storing media?*

Computer media are plastic-based and will degrade:

- at temperatures above 180°F
- when exposed to the high humidity (usually 100%) present during a fire in an ordinary fire-resistive filing cabinet or safe

Don't store media in the fire-resistive filing cabinet or safe that you use for your paper records.

Store computer media (floppy disks, CDs, zip disks, tapes) in a container that will maintain an interior temperature of not more than 125° F during a one hour exposure to an exterior temperature of 1700°F. The container can be a media safe or a mixed media file. Media boxes are acceptable if you store them in an appropriately rated insulated records file.

7. *What are the differences between a media safe, a mixed media file, and a media box?*

Media safes or files are designed to protect computer media. The UL rating is “Fire-Resistive Safe, Class 125-4, 3, 2, or 1 Hour”.

A mixed-media container is a fire-resistive filing cabinet or safe for paper records that has a media container. The container may be removable. It gives additional insulation against heat and protection against high humidity. The UL rating for the media container is “Class 125-4, 3, 2, or 1 Hour” when it is inside the cabinet. Outside the cabinet, the media container may have no rating or a rating of only one-half hour.

A media box is a small, portable container, usually with a lock. You can use media boxes to hold a small amount of media at your desk during the work day. Most media boxes have only a 150°F one-half hour rating. Don't use a media box to protect your data unless you keep it inside a fire-resistive filing cabinet.

8. *Are there requirements for the room where I store museum records?*

Yes. You want the room where you store your museum records to be as fire-resistant and secure as possible.

- Don't store flammable materials in the room.
- Lock the room against unauthorized access.
- Install fire detection and suppression systems.
- Install intrusion detection systems.

Consult with the park safety officer and law enforcement specialist, a local fire marshall, or another qualified expert. They can help you assess the room and make recommendations to improve it.

Refer to *MH-I*, Chapter 9: Security and Fire Protection and Appendix G: Museum Collections Protection for additional information.

G. Information Protection

1. *Can the NPS protect sensitive or confidential information that the park has acquired as part of documentation activities?*

No. The NPS may acquire sensitive or confidential information during record keeping and documentation activities. In certain circumstances, the Freedom of Information Act (FOIA) may require that the NPS release such information. You must inform parties that request confidentiality of information that the NPS:

- won't voluntarily share this information, *but*
- can't guarantee confidentiality

2. *Where can I find more information about protecting sensitive or confidential information?*

Refer to the NPS *Management Policies*, Chapter 5, Cultural Resource Management. For information on the Freedom of Information Act, refer to *MH-III*, Chapter 2: Legal Issues.

H. List of Figures

Figure 1.1

NPS Forms in ANCS+

NPS Forms in ANCS+

Refer to Chapter 5 in the *ANCS+ User Manual* for information on how to complete the forms. You can complete the following forms using ANCS+ or Word.

Accession Forms

Accession Receiving Report, Form 10-95 Rev.
Deed of Gift, Form 10-830 Rev.
Accession Folder Cover Sheet, Form 10-255 Rev. – Word document
Source of Accession Card

Catalog-Related Forms

Museum Catalog Record-CR, Form 10-254 Rev.
Museum Catalog Record-NH, Form 10-254B Rev.
Receipt for Property, DI-105
List of Objects, Form 10-417
Object Condition Report, Form 10-637
Inventory of Museum Property, Form 10-349
Collections Management Report, Form 10-94 Rev.
Object Temporary Removal Slip, Form 10-97

Natural History Labels

Vertebrate Wet Specimen Label, Form 10-500
Vertebrate Specimen Label, Form 10-501
Skull Vial or Box Label, Form 10-502
Invertebrate Specimen Label, Form 10-503
Geology Collection, Form 10-504
Paleontology Label, Form 10-505
Wet Plant Specimen Label, Form 10-506
Invertebrate Label, Form 10-507
Egg Box Label, Form 10-508
Insect Label, Form 10-509
Annotation Label, Form 10-510
Mineral Collection, Form 10-511
Herbarium Collection, Form 10-512

Loan Forms

Incoming Loan Agreement, Form 10-98 Rev.
Outgoing Loan Agreement, Form 10-127 Rev.
Outgoing Loan Folder Cover Sheet, Form 10-640 Rev.
Outgoing Loan Extension, Form 10-641

Deaccession Forms

Deaccession Form, Form 10-643 Rev.
Deaccession Folder Cover Sheet, Form 10-644 Rev. – Word document
Transfer of Property, DI-104
Conveyance Agreement, Form 10-99
Exchange Agreement – Word document
Repatriation Agreement – Word document
Specialist Review Form

Archives Forms

Archives and Manuscript Collections Separation Sheet, Form 10-645 – Word document
Folder List, Form 10-96 Rev. – Word document

Figure 1.1. NPS Forms in ANCS+

Chapter 2: Accessioning

	<u>Page</u>
A. Overview	2:1
What is accessioning?	2:1
Who must follow this chapter?	2:1
B. General Information on Accessions	2:1
What is an accession?	2:1
What are accession records?	2:1
When do I accession objects?	2:2
How soon must I catalog objects after accessioning them?	2:2
What are the types of NPS accessions?	2:2
What is a transfer of ownership document?	2:2
Where do I get the forms for accessioning?	2:3
Who reviews and makes recommendations about potential accessions?	2:3
Who signs the transfer of ownership document?	2:3
Must I accession objects left at the park for identification or consideration as a possible acquisition?	2:3
What if previous accessions lack the documentation outlined in this chapter?	2:3
Can an object have more than one accession number?	2:4
C. Acquisition Policies	2:4
What is the best accession policy?	2:4
Must all accessions fit within the SOCS?	2:4
Why is it important to make sure that accessions fit within the SOCS?	2:4
May a park acquire collections if it doesn't have the facilities or staff to manage them?	2:4
May I accession collections if I intend to deaccession them?	2:4
Should I encourage the park to acquire collections?	2:4
Do I accession reproductions?	2:5
D. Special Considerations for Accessions	2:5
What do I need to know about illicit trade?	2:5
Are there special acquisition considerations for archival and manuscript collections?	2:6
Are there special procedures for acquiring archival and manuscript collections?	2:6
Are there special considerations for acquiring firearms?	2:6
Are there special considerations for acquiring NAGPRA material?	2:6
Are there special requirements for acquiring threatened and endangered species?	2:6
Are there health and safety considerations when acquiring collections?	2:7
E. Acquiring Copyrights	2:7
What are copyrights?	2:7
Why is it important to consider copyrights when acquiring museum collections?	2:7
What types of material have copyrights?	2:7
How do I determine who owns the copyrights?	2:7
How does the owner transfer the copyrights?	2:7
What if the owner doesn't want to transfer the copyrights?	2:8
What if the owner is willing to transfer some, but not all, of the copyrights?	2:8
What are some questions to ask when acquiring museum collections that have copyrights?	2:8
F. Gifts	2:8
What is a gift?	2:8
Who has the authority to accept gifts?	2:9
How do I document a gift?	2:9
How do I acknowledge a gift?	2:9
Does the NPS prohibit donations from certain sources?	2:9

When should I refuse a gift?.....	2:9
Can a park refuse a bequest?.....	2:10
Are there special considerations for bequests?	2:10
Can a park solicit donations?	2:10
Can a park receive a donation for a fractional interest in an object?.....	2:10
G. Gift Considerations	2:10
Does a gift automatically include copyrights?.....	2:10
Can a donor place restrictions on a gift?	2:11
Can I accession gifts into the collection to use in a deaccession?	2:11
Are donations tax deductible?.....	2:11
Can NPS staff appraise donations?.....	2:11
Are there special considerations for gifts of archival and manuscript collections?	2:12
What if I don't have a deed of gift on file for previous accessions?	2:12
May a park receive a donation of NAGPRA material?.....	2:12
What other types of documentation should I get for a gift?.....	2:12
Can I restrict access to donor information?	2:12
H. Purchases.....	2:13
What is a purchase?.....	2:13
Who has the authority to purchase museum objects?	2:13
How do I document a purchase?	2:13
Can a park use appropriated funds to purchase museum collections?.....	2:13
Can a park accept donations of cash to use for purchasing museum collections?	2:13
Can a park solicit donations of money to purchase museum collections?.....	2:14
Can a park conduct a fundraising campaign for money to purchase museum collections?.....	2:14
Can a park establish endowments to provide a permanent source of money to purchase museum collections?.....	2:14
How do I acknowledge a donation of money to use for purchasing museum collections?	2:14
I. Purchase Considerations	2:14
Do I need an ownership statement from the vendor?	2:14
What information should an ownership statement contain?	2:14
Does a purchase automatically include copyrights?	2:15
May I purchase firearms for the museum collection?.....	2:15
May I purchase NAGPRA material?	2:15
How do I record purchases that Harpers Ferry Center makes for exhibit or furnishings projects?.....	2:15
How do I record purchases by the park's cooperating association for the park's museum collection?.....	2:16
What is a purchase contract?.....	2:16
What do I need to include in a purchase contract?	2:16
Are there special considerations for purchasing archival and manuscript collections?	2:16
Should I get an appraisal for objects that the park wants to purchase?.....	2:16
What other types of documentation should I get for a purchase?	2:17
J. Exchanges.....	2:17
What is an exchange?	2:17
Who has the authority to make exchanges?	2:17
How do I document an exchange?	2:17
Does the NPS prohibit exchanges with certain sources?	2:18
Does the NPS have an order of preference for sources of exchanges?.....	2:18
K. Exchange Considerations	2:18
Must exchanges be of equal value?	2:18
Must the objects in an exchange be appraised?	2:18
Where can I find information about appraisals for exchanges?.....	2:19
Can I exchange natural history specimens?.....	2:19

Does an exchange automatically include copyrights?	2:19
Can I acquire NAGPRA material through an exchange?.....	2:19
Are there special considerations for acquiring archival and manuscript collections through an exchange?.....	2:20
May I accession objects expressly to use them in an exchange?	2:20
Who pays the transportation costs for an exchange?	2:20
What other types of documentation should I get for an exchange?	2:20
L. Transfers	2:20
What is a transfer?.....	2:20
Who has the authority to accept transfers?	2:20
How do I document a transfer?	2:20
Do I need an ownership statement for a transfer?	2:20
M. Transfer Considerations	2:21
Does a transfer automatically include copyrights?	2:21
How can I find out if other parks or agencies have material for transfer?	2:21
What if I don't have a transfer form on file for previous accessions?	2:21
May I receive a transfer of NAGPRA material?.....	2:21
Are there special considerations for acquiring archival and manuscript collections through a transfer?	2:21
Who pays transportation costs for a transfer?.....	2:22
What other types of documentation should I get for a transfer?	2:22
N. Field Collections	2:22
What is a field collection?	2:22
How do I document a field collection?	2:22
What if I receive collections from a field collection over a period of time in more than one batch?	2:23
Can I accession field collections that are not at the park?.....	2:23
What are field records?	2:23
Do I accession the field records when I accession a field collection?	2:24
Do field records automatically include copyright?	2:24
Are there restrictions on field records?	2:24
What if a field collection involves NAGPRA material?	2:25
O. Other Field Collections	2:25
What is an unauthorized field collection?	2:25
How do I document an unauthorized field collection?.....	2:25
Do I accession objects that were manufactured in the park as a field collection?	2:26
Do I accession objects without accession documentation as a field collection?.....	2:26
How can I make sure the documentation for an accession is really missing?	2:26
How do I accession objects that don't have documentation?	2:27
Does the park own the copyrights on materials found in the collection?.....	2:27
P. Incoming Loans	2:27
What is an incoming loan?	2:27
Why does the NPS accession incoming loans?.....	2:27
For what purposes may I borrow museum objects?	2:28
Must the objects I borrow fit within the park's SOCS?	2:28
How do I document a loan?	2:28
For how long may I borrow museum objects?.....	2:28
Must I catalog incoming loans?.....	2:28
Who makes the loan?.....	2:28
Q. Incoming Loan Considerations	2:28
May I make third-party loans?.....	2:28
Are there special procedures for loans between parks?.....	2:29

Are there special procedures for loans between parks and NPS centers?	2:29
Must I inventory incoming loans?	2:29
Are incoming loans subject to NPS collections management policies?	2:29
Where do I get the forms for incoming loans?	2:29
Does an incoming loan include copyrights?	2:30
R. Processing and Documenting Incoming Loans	2:30
Loan Identification and Review	2:30
Loan Requests	2:30
Insurance	2:30
Shipping	2:30
Loan Agreement	2:31
Attachments to the Loan Agreement	2:31
Signing the Loan Agreement	2:32
Filing the Loan	2:32
Receiving the Objects	2:32
S. Tracking Incoming Loans	2:33
ANCS+ Loans In Associated Module	2:33
Monitoring and Recall	2:33
Loan Extensions	2:34
Loan Termination	2:34
Documenting a Loan Return	2:34
T. Old Loans	2:35
What is an old loan?	2:35
Why is it important to resolve old loans?	2:35
How do I go about resolving an old loan?	2:35
How should I contact the lender?	2:36
What should I do to locate a missing lender?	2:36
What if I'm unable to locate the lender or legal owner?	2:37
What if someone other than the lender claims to own the property?	2:37
What if more than one person claims to be the owner of the property?	2:37
Does the park own the copyrights on materials in unclaimed loans?	2:37
What do I do if the loan remains unclaimed?	2:38
May I deaccession objects from unclaimed loans?	2:38
What do I do if the owner comes forward after I accession the unclaimed loan as a gift?	2:38
U. Accession Book	2:38
What is the accession book?	2:38
May a park have more than one accession book?	2:38
Should I store the accession book in a special place?	2:38
Should I make a copy of the accession book?	2:39
How do I make an entry in the accession book?	2:39
How do I make corrections to the accession book?	2:41
What if I find that an object is in the wrong accession?	2:41
How do I correct an entire accession book page?	2:42
What if I need to recopy the entire accession book?	2:42
What if I need to rebind the accession book?	2:43
Should I replace or deacidify my accession book if it is acidic?	2:43
V. Documenting Accessions	2:43
Receipt of Objects	2:43
Accession Receiving Report	2:44
Recording Condition	2:45
List of Objects	2:45

ANCS+ Accession Records	2:45
Accession Book	2:46
Tagging and Storing Objects.....	2:46
Accession Folder	2:46
Required Documents in the Accession Folder	2:47
Other Documents in the Accession Folder	2:48
Outgoing Loan and Deaccession Documents in the Accession Folder	2:49
Accession File.....	2:49
Source of Accession.....	2:49
Changing Accession Type	2:50
W. List of Figures	2:51

BASIC REQUIREMENTS FOR NPS ACCESSIONS

Accession all objects, specimens, and archival and manuscript collections that are part of the park's museum collection. Accession museum collections when you receive them.

Only accession museum collections that fit within the park's Scope of Collection Statement and that the park can manage according to NPS policies and standards.

An accession can be from only one source. Accession museum collections as one of the following types of transactions: gift, purchase, exchange, transfer, field collection, or incoming loan. Read the appropriate sections of this chapter for the type of accession you are documenting. There are special documentation requirements that you should be aware of for each accession type.

There must be a transfer of ownership document for a gift, purchase, exchange, or transfer.

- gift – Deed of Gift (Form 10-830 Rev.)
- purchase – an appropriate purchase document, such as a DI-1 or Procurement Request and invoice
- exchange – exchange agreement
- transfer – Transfer of Property (DI-104)

Field collections, such as archeological and natural history collections, are collected on park property. Field collections don't require a transfer of ownership document. Use the Accession Receiving Report (Form 10-95 Rev.) to document field collections.

Incoming loans require an Incoming Loan Agreement (Form 10-98 Rev.) to document transfer of custody.

The superintendent must approve all accessions and sign all transfer of ownership documents and incoming loan agreements.

Assign an accession number to all accessions. The NPS accession number consists of the park acronym, a dash, and a number. Tag the objects in the accession with the accession number and store them in an accession storage area until you can catalog them.

Isolate infested or unsafe collections immediately to avoid contaminating other material. Stabilize these collections after consulting with a conservator.

Enter all accessions into ANCS+. Print the accession forms from ANCS+.

Complete an Accession Receiving Report (Form 10-95 Rev.) that lists the objects in the accession for all accessions. Record the condition of the objects.

Enter all accessions into the Accession Book (Form 10-256).

Set up an accession folder for each accession. Store all documents for the accession in the folder.

Store all accession folders and the accession book in an insulated, locked file. Control access to this file.

CHAPTER 2: ACCESSIONING

A. Overview

1. *What is accessioning?*

Accessioning is the process of officially accepting items into National Park Service (NPS) museum collections. Accessioning establishes legal custody and ownership and provides information on how the NPS acquired the items. This chapter discusses the various ways to acquire collections and explains the basic procedures for documenting accessions.

2. *Who must follow this chapter?*

The staff person responsible for the museum collection must follow this chapter to accession museum objects and archival collections. You must accession all items that are part of the park's permanent museum collection and all incoming loans.

See Section A.6 of Chapter 1 in this handbook for information on staffing requirements for museum collections.

The NPS treats incoming loans as accessions. This chapter includes procedures on incoming loans. An incoming loan establishes custody but not ownership.

B. General Information on Accessions

1. *What is an accession?*

An accession is the acquisition of a single item or a group of items:

- from one source
- under one type of transaction (for example, gift)
- on one date

For example, an individual may sell a rifle to the park, and at the same time donate twenty Civil War documents. You would record this as two accession transactions: a purchase and a gift. If the same individual donates additional material one month later, this would be a third transaction. An accession can have one object or thousands of objects.

2. *What are accession records?*

Accession records document the legal transaction that establishes ownership (title) and custody of museum objects. Accession records also document general information about the accession. They consist of the accession book, the accession file, and the Automated National Catalog System (ANCS+) accession database. The accession file contains all pertinent documentation about the accession. It's important to keep records of all the steps you take in the acquisition process.

The accession book and accession file are permanent park records that must remain at the park. Restrict access to these records to the extent permitted by law.

Note: Catalog records provide detailed information about the items in an accession. All museum items must have both an accession number and a catalog number. Refer to Chapter 3 in this handbook for information on cataloging.

3. *When do I accession objects?*

You must accession objects upon receipt. Accessioning is the first step in documenting museum collections. No park should have an accessions backlog.

Note: In 1984, the Director issued a call to accession all museum collections. The call also included an instruction to keep up-to-date accession records for all future accessions.

4. *How soon must I catalog objects after accessioning them?*

Catalog accessions as soon as possible. Accessioned but uncataloged objects are a backlog of work that needs immediate attention. This material isn't a useful part of the collection until you catalog it. Uncataloged material is also more vulnerable to theft, since it lacks identifying numbers and descriptive catalog record data.

5. *What are the types of NPS accessions?*

There are six types of NPS accessions:

- gift
- purchase
- exchange
- transfer
- field collection
- incoming loan

Gifts, purchases, exchanges, and transfers are permanent and involve a transfer of ownership (title). Field collections document the collection of objects that are already park property. Incoming loans are temporary accessions involving a transfer of custody, not ownership.

Refer to Sections F-Q for specific information on the types of accession transactions.

Note: If you're not sure which accession type to use, consult your regional/support office (SO) curator or other curators with similar transactions. Once you make a determination, justify the decision in the accession file.

6. *What is a transfer of ownership document?*

Each accession must have a document transferring ownership (title) or custody. The type of document depends upon the type of accession transaction. For example, you must use a deed of gift to document accessions that the park receives as gifts. The document provides the basis for the park's claim to legal title and custody.

Refer to Sections F-Q for specific information on the types of accession transactions.

7. *Where do I get the forms for accessioning?*

Use ANCS+ to print blank or completed accession forms. Use acid-free paper to print the forms.

Acid-free paper is available from the Supply and Equipment Program of the Museum Management Program (MMP), National Center for Cultural Resources.

8. *Who reviews and makes recommendations about potential accessions?*

The curator and curatorial staff review all potential accessions and make recommendations to the superintendent. You should consult subject-matter specialists as needed.

The superintendent may choose to set up a collections advisory committee to review and make recommendations about potential accessions. A collections advisory committee is recommended, but not required, for accessions. The curator should be a member of the committee. Other members should represent relevant disciplines, depending on the type of material to review.

Note: The park must use a collections advisory committee for some types of deaccessions. The superintendent may want to use the same committee for accessions. Refer to Section C.4 of Chapter 6 in this handbook for information about the collections advisory committee.

9. *Who signs the transfer of ownership document?*

The superintendent and the authorized source of accession (such as the owner or institutional official) must sign the transfer of ownership document.

10. *Must I accession objects left at the park for identification or consideration as a possible acquisition?*

No. If the objects are there for less than 30 days, you don't have to accession them. However, you should discourage people from leaving objects at the park, especially if you can't provide a prompt response. For periods of less than 30 days, you may use a Receipt for Property, DI-105 (Figure 2.1). Note on the receipt the date that the owner must retrieve the property. Include the owner's name, address, and phone number on the receipt. File and track the receipt by the date of return.

You must accession material that is left at the park for more than 30 days as an incoming loan.

Note: Frequently taxonomists need to borrow specimens from other repositories to identify species. You can issue a receipt for property in these instances if the park doesn't keep the specimens for over 30 days.

11. *What if previous accessions lack the documentation outlined in this chapter?*

You must make a good faith effort to get the documentation. For example, the accession may lack a transfer of ownership document. If the other party to the transaction is still available, draft the required document and get it signed and dated. Attach a note that the document confirms a transaction made on an earlier date.

In the absence of any legal documentation, record all actions taken to trace the accession. At a minimum, complete the Accession Receiving Report, Form 10-95 Rev. (Figure 2.2). Refer to Section N of this chapter for additional information on recording undocumented accessions.

12. *Can an object have more than one accession number?*

No. An object can have only one accession number, which represents one accession transaction.

Archival collections can have more than one accession number. Refer to Appendix D: Museum Archives and Manuscript Collections, in this handbook.

C. Acquisition Policies

1. *What is the best accession policy?*

The best accession policy is a good Scope of Collection Statement (SOCS). All parks must have an approved SOCS that provides the basis for reviewing potential acquisitions. This document outlines the type of collections that:

- are essential to fulfilling the park's mission
- will enhance interpretation and research at the site
- legislation requires the park to preserve and maintain

Refer to the *Museum Handbook*, Part I (MH-I), Chapter 2: Scope of Museum Collections, for guidance on writing a SOCS. This chapter also has a section on acquisition criteria.

2. *Must all accessions fit within the SOCS?*

Yes. However, a museum collection may have objects from previous accessions that don't fit within the SOCS. The park's SOCS may also change over the years. In both these cases, you may deaccession objects that no longer fit within your SOCS. Refer to Chapter 6: Deaccessioning, in this handbook.

Note: Accessions that involve special short-term loans for exhibit don't have to fit within the SOCS.

3. *Why is it important to make sure that accessions fit within the SOCS?*

When you accession an object, it becomes subject to NPS regulations for museum property. Museum collections require money, staff time, and specialized supplies and equipment for proper maintenance, preservation, and use. For these reasons, you should carefully review acquisitions to make sure that they fit within the SOCS.

4. *May a park acquire collections if it doesn't have the facilities or staff to manage them?*

No. A park should only acquire museum collections that it can manage according to NPS policies and standards.

5. *May I accession collections if I intend to deaccession them?*

No. You may not accession objects outside the park's SOCS with the intent of deaccessioning them. Accessions are permanent additions to the museum collection that must fit within the park's SOCS. You may not acquire a collection with the intention of deaccessioning part of it.

6. *Should I encourage the park to acquire collections?*

Yes. You should make every reasonable effort to acquire museum collections that:

- become available and fit within the park's SOCS

- you can manage and make accessible according to NPS standards

For guidance and justification on acquisitions, refer to:

- the park’s SOCS
- historic furnishings reports
- archival assessments
- exhibit plans
- natural resources inventory and monitoring guidelines
- subject-matter specialists

7. *Do I accession reproductions?*

Yes. You accession and catalog reproductions. You don’t accession living history items (unless they are left on exhibit when not in use) or exhibition aids. Refer to Section IV in Chapter 4 of this handbook for additional information. There are special marking guidelines that help differentiate reproductions from originals.

D. Special Considerations for Accessions

1. *What do I need to know about illicit trade?*

Illicit trade involves illegal trafficking in museum items. You need to be aware of the manner in which the current and previous owner(s) obtained the material you plan to accession.

The owner(s) must have collected the material in an ethical manner compatible with professional disciplines and museum standards.

The owner(s) must have collected, exported, imported, transported, or otherwise obtained and possessed the material in full compliance with the laws and regulations of the:

- country of origin
- the United States federal government (including NAGPRA)
- individual states within the U.S.

You must make a reasonable effort to make sure that the owner(s) acquired the objects legally. The amount of effort depends on the type and value of the material. For example, get a complete provenience history from the owner. If you have any doubts about the material, check with organizations or offices that list missing or stolen objects. Refer to Section III in Chapter 4 of this handbook for a list of organizations.

Report suspect materials to the superintendent and the regional/SO curator. If you unknowingly accession objects in violation of this policy, you must make every possible effort to return the objects to the rightful owner.

2. *Are there special acquisition considerations for archival and manuscript collections?*

Yes. It is especially important to get the copyrights for archival or manuscript collections.

If possible, get signed release forms from individuals who appear in oral history or videotapes, photos, digital files, and motion pictures. Without a release form, you must get permission to use these materials in publications or exhibits or provide them to researchers. Refer to the *Museum Handbook*, Part III (*MH-III*), Chapter 3: Publications, for a sample release form.

3. *Are there special procedures for acquiring archival and manuscript collections?*

Yes. Archivists use the process of appraisal and evaluation to determine if a collection has value for a park. Refer to Sections A and G in Appendix D of this handbook for information on the categories of archival value and the appraisal process.
4. *Are there special considerations for acquiring firearms?*

Yes. The acquisition of firearms must be in compliance with all state and local law enforcement regulations. Consult the law enforcement personnel at your park for information on state and local regulations.
5. *Are there special considerations for acquiring NAGPRA material?*

Yes. NAGPRA refers to the Native American Graves Protection and Repatriation Act [P.L. 101-601; 25 USC 3001-3013; 104 Stat. 3048-3058]. The law requires you to consult with affected Native American groups if a proposed accession involves Native American:

 - human remains
 - associated and unassociated funerary objects
 - sacred objects
 - objects of cultural patrimony

Refer to the *Cultural Resource Management Guideline*, Appendix R: NAGPRA, for further information on NAGPRA compliance.
6. *Are there special requirements for acquiring threatened and endangered species?*

Yes. You can only acquire threatened and endangered species if the collector:

 - has a valid permit from the United States Fish and Wildlife Service or the National Marine Fisheries Service to collect a threatened or endangered species, *and*
 - has met all applicable requirements from the state, local government, tribal government, or foreign country to collect a threatened or endangered species

You may receive a gift of endangered or threatened species if the donor:

 - has proof of pre-Act ownership, *and*
 - the specimens haven't been offered for sale since the date of the Endangered Species Act.

The park must have a permit to purchase threatened and endangered species and objects that contain their parts.

7. *Are there health and safety considerations when acquiring collections?*

Yes. You need to get any treatment history for objects. This is especially important for organic objects that may have been treated with pesticides such as arsenic. If there is no written record, then interview the source.

Refer to the *MH-I*, Chapter 11: Health and Safety, for information on hazardous materials that have been used on objects. Section 2 in the *Conserve O Gram (COG)* series has information on arsenic, dichlorvos (vapona) and other hazardous materials.

E. Acquiring Copyrights

1. *What are copyrights?*

Copyrights are special property rights that legally grant creators, such as artists and authors, exclusive rights to their work. The copyrights to a work consist of a group of rights that a creator can transfer separately from the actual work. Copyrights include the right to reproduce a work, to publicly display it, and to distribute copies by sale.

2. *Why is it important to consider copyrights when acquiring museum collections?*

Acquiring an object without acquiring the copyrights can severely limit the park's use of the object. NPS acquisition policy requires parks to:

- determine who owns the copyrights
- if possible, have the owner transfer the copyrights to the NPS

3. *What types of material have copyrights?*

Copyrights cover original material in fixed form, such as paintings, photographs, sound recordings, and archival materials. Refer to the *MH-III*, Chapter 2: Legal Issues, for additional information on the types of material covered by copyrights.

Note: Government-produced documents and materials are in the public domain and don't have copyrights.

4. *How do I determine who owns the copyrights?*

The creator usually owns the copyrights to his/her work. If you are acquiring the work from someone other than the creator, ask for supporting documentation of copyright ownership.

Frequently, the owner may not know who has the copyrights. You'll then have to research the copyright status of the work. Refer to the *MH-III*, Chapter 2: Legal Issues, for information on the length of copyright protection. This chapter also includes steps you can take to research copyright.

The U.S. Copyright Office, Library of Congress, publishes several circulars on copyright, including Circular 22: *How to Investigate the Copyright Status of a Work*. Call 202-707-9100, or access their publications on-line at <<http://www.loc.gov/copyright/circs/>>.

5. *How does the owner transfer the copyrights?*

The NPS Deed of Gift, Form 10-830 (Figure 2.3) and sample exchange agreement (Figure 2.8) include copyright ownership and transfer statements. You can use a transfer of copyright statement (Figure 2.7) with purchases and transfers.

You must have a written transfer of copyright interests.

Note: Materials in an archival collection may contain copyrightable works, such as letters and photographs, from other people. The owner of the collection can't transfer the copyrights to these works. You must negotiate with the original creator to get the copyrights to these works.

6. *What if the owner doesn't want to transfer the copyrights?*

You must seriously consider whether to accept an object/archival collection that doesn't include a transfer of copyrights. If you don't own the copyrights, you have a restriction on the material.

Negotiate with the copyright owner to get as many copyrights as possible. At the very least, get written permission to use the materials for special purposes, such as park publications and exhibitions.

7. *What if the owner is willing to transfer some, but not all, of the copyrights?*

In some cases, the copyright owner may be willing to transfer some, but not all, of the copyrights. Clearly document which copyrights the park is receiving on the deed of gift, exchange agreement, or copyright statement. Also place a prominent note in the accession file to document which copyrights the park doesn't own.

8. *What are some questions to ask when acquiring museum collections that have copyrights?*

When you're acquiring and accessioning objects/archival collections that have associated copyrights, ask yourself the following questions:

- How long are the copyrights in effect?
- Who owns the copyrights? Has anyone researched the copyright status and ownership?
- Has the owner transferred all copyrights in writing? Where is the documentation for the transfer?
- If the owner hasn't transferred all copyrights, which ones does the park own? Which copyrights does the owner keep?
- If the owner won't transfer the copyrights, has there been a review and justification for acquiring the material without copyrights?

Be sure to document the answers to these questions. Store this information in the accession folder.

F. Gifts

1. *What is a gift?*

Gifts are outright donations from individuals or institutions, as well as bequests (posthumous gifts made in a will). The donor owns the property and transfers ownership to the NPS. The donor must warrant that he/she has full legal title to the object(s) and has full power and authority to donate the object(s) to the NPS. There can be no liens or other encumbrances of any kind against the gift or title to it.

2. *Who has the authority to accept gifts?*

The park superintendent has the delegated authority, through the Museum Properties Act of 1955, to accept donations. The superintendent cannot redelegate this authority. Single donations valued at \$1 million or more require the Director's approval.

The NPS reserves the right to decline any gift.

3. *How do I document a gift?*

You must use the Deed of Gift, Form 10-830 Rev. (Figure 2.3) to document gifts to the NPS. As part of the accessioning process, complete a deed of gift that lists the objects in the gift. The deed of gift is a formal, legal agreement that transfers ownership and legal rights.

You can print a blank or completed deed of gift from ANCS+. Be sure to print this form on acid-free paper.

Make two copies of the deed of gift. The donor or authorized agent and the superintendent sign both copies of the form. The park keeps one copy in the accession folder, and the donor keeps the other copy.

4. *How do I acknowledge a gift?*

The superintendent should write a letter acknowledging receipt of the gift and thanking the donor for his or her support. If you send the letter with the deed of gift, you can include instructions for the donor to sign and return one copy of the deed of gift to the park. Refer to Figure 2.4 for a sample acknowledgement letter.

The letter is an official and personal expression of appreciation. It makes reference to the objects in the donation, and explains the importance of the donation to the museum. It might also mention that the gift is tax deductible to the extent permitted by law.

For some gifts, you may want to use a gift acknowledgement certificate (Figure 2.5). You can get gift certificates from the Supply and Equipment Program of the Museum Management Program, National Center for Cultural Resources.

You can also credit the donor through press releases, public events, and unobtrusive credit lines. The accession information should include the preferred credit line, if appropriate, such as "A gift from the J.H. Smith Family." Refer to Director's Order #21 for guidelines on donor recognition.

Note: You might want to publicize significant accessions to increase public awareness of the museum collection.

5. *Does the NPS prohibit donations from certain sources?*

Yes. Refer to Director's Order #21: Donations and Fundraising, for a list of prohibited sources of donation. For example, a park can't accept donations from persons or entities when acceptance would create a conflict of interest or the appearance of a conflict of interest for the NPS or the Department of the Interior.

6. *When should I refuse a gift?*

The superintendent should decline to accept a gift if:

- the material doesn't fit within the park's SOCS
- the park doesn't have the facilities or staff to manage the material according to NPS standards

- the object is not in good condition

Note: When declining a gift, thank the potential donor for his/her interest in the museum, and explain why the park can't accept the material. If possible, note other parks or museums that may have an interest in the material. The American Association of Museums (AAM) *The Official Museum Directory* is a good source for non-NPS museums.

7. *Can a park refuse a bequest?*

Yes. A park can refuse a bequest or only accept part of the material in the bequest. Consult the regional/SO curator before refusing a bequest. Other parks may be in need of the material.

8. *Are there special considerations for bequests?*

Yes. The lawyers for the estate may use a deed of gift or gift of personalty to document the gift. With the approval of the estate lawyers, you may use the NPS deed of gift form as the title transfer document.

In addition, document the bequest with:

- a copy of the provision of the will that concerns the bequest
- a final receipt accepting the objects in the bequest

Note: A bequest is not final until a court approves the administration of the estate.

9. *Can a park solicit donations?*

No. You may not ask for a donation of museum objects. Refer to Director's Order #21 for prohibitions against soliciting.

You may:

- describe the needs of the museum if a potential donor expresses interest
- respond to questions on how to make a donation
- get your friends group to approach a potential donor for you
- describe the needs of the museum to the general public

10. *Can a park receive a donation for a fractional interest in an object?*

Yes. This is a rare transaction, but a park can acquire an object as a partial gift and a partial purchase. The park pays a portion of the value of the object, and the seller donates a portion of the value. Record the transaction as a purchase, but document the partial donation with a deed of gift. Document the entire transaction on the accession receiving report.

G. Gift Considerations

1. *Does a gift automatically include copyrights?*

No. The Deed of Gift, Form 10-830 Rev. (Figure 2.3) allows the donor to transfer all copyrights. If the donor won't, or can't, transfer all copyrights, delete the copyright phrase from the deed of gift by drawing a line through it. Have both parties initial the change.

You should make every effort to get all copyrights when receiving gifts. Be aware that past gifts may not include copyrights.

Refer to Section E in this chapter for additional information on acquisitions and copyrights.

2. *Can a donor place restrictions on a gift?*

In accordance with NPS policy and general museum practice, you should only accept unrestricted gifts. Only the regional director can allow an exception to this rule. Gifts or bequests must be free of restrictions as to their use and future disposition. However, museum collections are subject to legal restrictions, such as privacy laws and classified data. Refer to the *MH-III*, Chapter 2: Legal Issues, for information on use and access restrictions.

You must carefully evaluate any restrictions on a proposed gift. Consult the regional/SO curator or solicitor or the DOI solicitor. Consider the park's need for the material, its intended use, and the impact of the restrictions on future collections management. Discuss potential gift restrictions, and negotiate with the owner for a more acceptable agreement.

Although counter to NPS policy, your collection may contain past acquisitions with donor restrictions. You must honor these restrictions to the extent allowed by law. Refer to the *MH-III*, Chapter 2: Legal Issues, for information on donor restrictions and the Freedom of Information Act (FOIA).

3. *Can I accession gifts into the collection to use in a deaccession?*

No. Gifts are permanent additions to the museum collection. You can't accession a gift with the intent to later deaccession the objects. Refer to Chapter 6: Deaccessioning, of this handbook for information on potential tax liabilities and the deaccession of gifts.

4. *Are donations tax deductible?*

Yes. Donations to the NPS are tax deductible to the extent permitted by law. The donor is responsible for:

- establishing the value of a gift for tax deduction purposes
- meeting Internal Revenue Service reporting requirements
- completing a Noncash Charitable Contributions form (IRS Form 8283)
- getting a professional (non-NPS) appraisal for items that total over \$5,000

The NPS must acknowledge a donation that totals over \$5,000 in one year by completing the donee acknowledgment portion of Form 8283. The donor will give you the form. Contact the regional/SO curator and regional solicitor if you have questions about noncash charitable contributions.

5. *Can NPS staff appraise donations?*

No. NPS staff may place values on objects for internal documentation and insurance purposes only.

NPS staff can't give donors monetary appraisals for donations.

Refer to Section IX in Chapter 4 of this handbook for information on appraisals.

6. *Are there special considerations for gifts of archival and manuscript collections?*

Yes. Getting all copyrights is especially important for archival and manuscript collections. See Section E in this chapter for information on copyrights. Be aware that archival collections may contain sensitive or legally-restricted material.

You also need to be aware of the need to get model and interview release forms as needed for the material in the collection. See Section D.2 in this chapter for information on release forms.

7. *What if I don't have a deed of gift on file for previous accessions?*

All gifts should have a signed, original deed of gift form on file. Gifts that the park received before 1985 might not have a deed of gift on file. Previous accessions may be documented by a donor letter signed by both parties or a last will and testament. Some early accessions may not have documentation of any kind.

Make every effort to get a signed deed of gift form if the donor, or donor's agent is still available. Note the earlier date of donation on the form. Document all your efforts to get a deed of gift. Keep this documentation in the accession file.

8. *May a park receive a donation of NAGPRA material?*

Yes. Consult with the affiliated Native American group when considering the acquisition. You must inform the donor that the park may repatriate the gift in response to a request from an affiliated group. You must add the material to the park's NAGPRA inventory or summary and continue to consult with the affiliated group(s). Follow the guidelines in the *Cultural Resource Management Guideline*, Appendix R: NAGPRA Compliance.

9. *What other types of documentation should I get for a gift?*

Get as much information as you can from the donor. You may not be able to get this information later, and it is of primary importance for documenting the object. Don't be afraid to ask questions. You may receive valuable information. Your interest may lead to additional donations that relate to the object. Donors may even spread the word of your interest, which may result in donations from others.

Make a paper copy of the donor information, and store it in the accession folder. You may also have donor information on media, such as tape or videotape. Place a reference in the accession file that includes the type of media and its location. If possible, create a written transcript of the media.

Note: Inform donors that the information they provide will become part of the public record and cannot be guaranteed absolute confidentiality. See Section G of Chapter 1 in this handbook for information on protecting sensitive or confidential information.

10. *Can I restrict access to donor information?*

Yes. Restrict access to donor names and addresses to the fullest extent of the law. You may have to release this information if you receive a Freedom of Information Act (FOIA) request. Refer to the *MH-III*, Chapter 2: Legal Issues, for information on FOIA requests.

H. Purchases

1. *What is a purchase?*

When you buy museum objects with park funds, you accession the objects as a purchase. The seller owns the property and transfers ownership to the NPS. The seller must warrant that he/she has full legal title to the object(s) and has full power and authority to sell the object(s) to the NPS. There can be no liens or other encumbrances of any kind against the object(s).

Note: Your park association or friends group may purchase museum collections for the park and then donate them to the park. These acquisitions are gifts, not purchases, since park funds were not used.
2. *Who has the authority to purchase museum objects?*

The park superintendent has the delegated authority to purchase museum collections at prices he or she considers reasonable. For major purchases, the superintendent should consult with an optional collections advisory committee or the regional/SO curator.
3. *How do I document a purchase?*

Documentation for purchases varies depending upon how you made the purchase and the purchasing authority for the park. Consult with your procurement staff for the appropriate way to make a purchase. Documentation includes:

 - receiving report copy of the Order for Supplies or Services, Form 10-3470(2-97) or OF-347
 - governmentwide purchase card (credit card) receipt
 - DI-1 Requisition or Procurement Request and invoice or sales slip or vendor's receipt
 - copy of the purchase contract

Note: If you don't have an original document, make an archival copy to include in the accession folder.
4. *Can a park use appropriated funds to purchase museum collections?*

Yes. A park can use appropriated funds in its budget for the purchase of museum collections. The curator or staff member responsible for the collection, can include the purchase of collections in budget requests.
5. *Can a park accept donations of cash to use for purchasing museum collections?*

Yes. The Museum Act of 1955 (16 U.S.C. 18f) authorizes the NPS to accept donations and bequests of money to purchase museum collections. Refer to Director's Order #21: Donations and Fundraising for a list of prohibited sources of donation. For example, a park can't accept donations from persons or entities when acceptance would create a conflict of interest or the appearance of a conflict of interest for the NPS or the Department of the Interior.

Single donations of \$1 million or more require the Director's approval.

6. *Can a park solicit donations of money to purchase museum collections?* No. You may not ask for donations of money to purchase museum objects. Refer to Director's Order #21 for prohibitions against soliciting.
- You may:
- describe the needs of the museum if someone expresses an interest in donating money for purchasing museum collections
 - respond to questions on how to donate money for purchasing museum collections
 - get your friends group to approach a potential donor for you
 - describe the needs of the museum to the general public
 - have a catalog of needs with cost estimates
7. *Can a park conduct a fundraising campaign for money to purchase museum collections?* No. However, a NPS partner, such as a friends group, may conduct fundraising campaigns for purchasing museum collections. The NPS partner must have a written agreement with the park. Refer to Director's Order #21 for guidelines on fundraising campaigns.
8. *Can a park establish endowments to provide a permanent source of money to purchase museum collections?* No. However, a NPS partner, such as a friends group, can establish and manage an endowment for the park. The NPS partner must have a written agreement with the park. Refer to Director's Order #21 for guidelines on endowments.
9. *How do I acknowledge a donation of money to use for purchasing museum collections?* The superintendent should write a letter acknowledging receipt of the cash donation and thanking the donor for his or her support. You can credit the donor through press releases, public events, and unobtrusive credit lines. The accession information should include the preferred credit line, if appropriate, such as "Purchased through a gift from the J.H. Smith Family." Refer to Director's Order #21 for guidelines on donor recognition.

I. Purchase Considerations

1. *Do I need an ownership statement from the vendor?* Yes. Get an ownership statement when you purchase museum collections. An ownership statement protects the park from purchasing stolen property or property acquired through illicit trade. It also gives a history of ownership for the objects.
- Note:** The need for an ownership statement is dependent on the type of sale and the value of the objects. It is especially important to get an ownership statement from private individuals.
2. *What information should an ownership statement contain?* An ownership statement should guarantee that the:
- seller is the owner or authorized agent for the owner of the property
 - seller owns clear and free title to the objects without liens or other encumbrances
 - objects are authentic and of the time period on the bill of sale

- seller has broken no customs, tax, records law, patrimony or other import and export laws or regulations

The seller should also note where he/she acquired the objects. A sample ownership statement appears in Figure 2.6.

3. *Does a purchase automatically include copyrights?*

No. You must have the seller sign a transfer of copyright statement to get the copyrights. A sample copyright statement appears in Figure 2.7.

You should make every effort to get all copyrights when purchasing museum collections. Be aware that past purchases may not include copyrights.

Refer to Section E in this chapter for additional information on acquisitions and copyrights.

4. *May I purchase firearms for the museum collection?*

Yes. However, you must be in compliance with all state and local law enforcement regulations.

You can't use the governmentwide purchase card to purchase firearms for the museum collection.

5. *May I purchase NAGPRA material?*

It depends on the material. You may not purchase human remains (either those subject to NAGPRA or those not subject to NAGPRA). In certain situations you may purchase funerary objects, sacred objects, or objects of cultural patrimony, if:

- the seller can verify that the original owner acquired the material legally
- the park acquires the material in compliance with NAGPRA, including consultation with the affiliated Native American group(s)

You must add the material to the park's NAGPRA inventory or summary. Follow the guidelines in the *Cultural Resource Management Guideline*, Appendix R: NAGPRA Compliance.

Note: You must be very cautious when purchasing NAGPRA material. It involves careful research and consultation to make sure that you don't acquire material in violation of the law. The park may have to pay for the services of a specialist to do the research.

6. *How do I record purchases that Harpers Ferry Center makes for exhibit or furnishings projects?*

Record objects that Harpers Ferry Center (HFC) purchases for exhibits and furnishings projects as purchases. HFC staff are acting as authorized agents for the park in making purchases with park or center money. HFC provides the park with purchase documentation that includes copies of sales receipts and information about the sale. The park signs a receipt for property when the objects arrive at the park.

7. *How do I record purchases by the park's cooperating association for the park's museum collection?* When the park's cooperating association purchases museum collections for the park, record the transaction as a gift.
8. *What is a purchase contract?* You may want to use a purchase contract for large or complex purchases, such as the purchase of an entire collection. A purchase contract spells out the conditions of the purchase.
9. *What do I need to include in a purchase contract?* There is no standard purchase contract. The content of the contract depends on the purchase. Confer with the procurement staff at the park. The regional/SO curator can assist you with writing a purchase contract. Some things to address in a contract include:
- proof of ownership
 - history of ownership (pedigree/provenance)
 - transfer of all rights, title, and interests
 - transfer of all copyrights
 - NAGPRA issues, if relevant
 - firearms restrictions, if relevant
 - warranty that the collection is free of pesticides and hazards or that they are identified
 - shipping and packing information
 - insurance information
 - date of purchase and possession
 - release forms for archives
10. *Are there special considerations for purchasing archival and manuscript collections?* Yes. Getting all copyrights is especially important for archival and manuscript collections. See Section E in this chapter for information on copyrights.
- Be aware that archival collections may contain sensitive or legally-restricted material. You also need to be aware of the need to get model and interview release forms as needed for the material in the collection. See Section D.2 in this chapter for information on release forms.
11. *Should I get an appraisal for objects that the park wants to purchase?* Yes. Get an appraisal for objects of high value in order to determine a fair purchase price. The seller may have an appraisal for the objects; however, the park may choose to get an independent appraisal.

12. *What other types of documentation should I get for a purchase?*

Get as much information as you can from the vendor. You may not be able to get this information later, and it is of primary importance for documenting the object. Don't be afraid to ask questions. If you don't get a response, document the fact that you asked. File the documentation in the accession folder.

J. Exchanges

1. *What is an exchange?*

You can acquire objects for the museum collection through an exchange. You exchange objects that are outside the park's SOCS for objects that fit the park's SOCS. An exchange involves both a deaccession and an accession. The owner of the property you acquire transfers ownership to the NPS. The owner must warrant that he/she has full legal title to the objects and has full power and authority to use the objects in an exchange. There can be no liens or other encumbrances of any kind against the objects you acquire or the title to those objects.

You must be able to justify that the objects you acquire:

- fit the park's SOCS
- fill a need at the park
- will receive adequate care
- are of museum quality, or fit archival appraisal criteria

Exchanges require the deaccession of museum collections. Refer to Chapter 6: Deaccessioning, in this handbook, for guidelines on deaccessioning.

2. *Who has the authority to make exchanges?*

The park superintendent has the delegated authority to make exchanges that are fair, justified, and in the public interest. For major exchanges, the superintendent should consult with an optional collections advisory committee or the regional/SO curator.

The superintendent must consult with a collections advisory committee for exchanges outside DOI (excluding the exchange of natural history specimens). See Chapter 6: Deaccessioning, in this handbook.

3. *How do I document an exchange?*

You must use an exchange agreement to document an exchange. The exchange agreement is a formal, legal agreement that transfers ownership and legal rights. A sample exchange agreement appears in Figure 2.8. You may create your own exchange agreement, but it must include the introduction and sections 1-9 of the sample exchange agreement.

You can print a blank or completed exchange agreement from ANCS+. Print the agreement on acid-free paper.

Make two copies of the exchange agreement. The superintendent and the

legal owner, or his/her authorized representative, sign both copies of the agreement. The park keeps one copy in the accession folder, and the other party keeps the other copy. If you use the optional deaccession folder, make a copy of the signed agreement for this folder.

The exchange agreement includes the following attachments:

- a list of the objects that the park is acquiring
- a list of the objects that the park is deaccessioning
- appraisals of the objects (this is only required for exchanges outside the federal government)
- an ownership statement (see Figure 2.6 for a sample statement)

Note: For exchanges within the federal government, write, “Not Applicable” in Section 4 of the exchange agreement.

4. *Does the NPS prohibit exchanges with certain sources?*

Yes. You must clearly justify and document all exchanges so that they can withstand any public or professional scrutiny. You cannot exchange with sources if there is a real or apparent conflict of interest. For example, NPS employees and their relatives cannot appear to benefit in any way from an exchange.

5. *Does the NPS have an order of preference for sources of exchanges?*

Yes. Follow the order of preference in Section K.2 of Chapter 6 in this handbook. You should try to keep museum objects in the public trust whenever possible. According to NPS procedures and generally accepted museum practice, exchanges with private individuals and non-educational or non-cultural institutions are not recommended. Only exchange with private individuals and entities if the exchange is well justified, and you can't acquire the objects by other means.

K. Exchange Considerations

1. *Must exchanges be of equal value?*

Objects in an exchange should be approximately equal in monetary value. However, it is sometimes appropriate to exchange NPS objects for objects of lesser value. This situation might occur when the park has a great need for the objects and has been unable to get them elsewhere. You must fully describe such circumstances in the justification for the exchange. Explain why the exchange is in the best interest of the NPS and the general public.

2. *Must the objects in an exchange be appraised?*

Yes, unless the exchange is within the federal government. The NPS requires formal appraisals for exchanges outside the federal government. Formal appraisals are standard museum practice for determining monetary value. You need appraisals to show that the objects in the exchange are approximately equal in value. Get a minimum of one formal, written appraisal (sometimes referred to as “an arms-length appraisal”) for objects below \$20,000 in value. Get two appraisals for objects over \$20,000 in value. You must have appraisals for the objects you deaccession and the objects you acquire.

Note: You don't need to do appraisals for most exchanges of natural history specimens. See question 4 below.

3. *Where can I find information about appraisals for exchanges?*

Refer to Section E of Chapter 6, in this handbook, for information on the appraisals you will need for an exchange. Refer to Section IX of Chapter 4, in this handbook, for information on appraisers and determining the value of objects.

4. *Can I exchange natural history specimens?*

Yes. The exchange of specimens is a common practice among scientists. The exchange of specimens doesn't require review by the collections advisory committee or a formal appraisal. However, for certain specimens, such as paleontology specimens, an appraisal may be appropriate. Consult the regional/SO curator before exchanging natural history specimens.

You may not exchange type or voucher specimens.

5. *Does an exchange automatically include copyrights?*

No. Section 5 of the sample exchange agreement allows the owner to transfer all copyright interests. You must include this section in any exchange agreement you create. If the owner won't, or can't, transfer all copyrights, delete the copyright section from the exchange agreement by drawing a line through it. Have both parties initial the change.

You should make every effort to get all copyrights when receiving museum collections. Be aware that past exchanges may not include copyrights.

Refer to Section E in this chapter for additional information on acquisitions and copyrights.

6. *Can I acquire NAGPRA material through an exchange?*

It depends on the material. You may not acquire human remains (either those subject to NAGPRA or those not subject to NAGPRA) through an exchange. In certain situations you may acquire funerary objects, sacred objects, or objects of cultural patrimony, if:

- the other party can verify that the original owner acquired the material legally
- the other party, if a museum, is in compliance with the NAGPRA statute
- the park acquires the material in compliance with NAGPRA, including consultation with the affiliated Native American group(s)

You must add the material to the park's NAGPRA inventory or summary. Follow the guidelines in the *Cultural Resource Management Guideline*, Appendix R: NAGPRA Compliance.

Note: You must be very cautious when acquiring NAGPRA material in an exchange. It involves careful research and consultation to make sure that you don't acquire material in violation of the law. The park may have to pay for the services of a specialist to do the research.

7. *Are there special considerations for acquiring archival and manuscript collections through an exchange?* Yes. Getting all copyrights is especially important for archival and manuscript collections. See Section E in this chapter for information on copyrights.
- Be aware that archival collections may contain sensitive or legally-restricted material. Be aware that you must get model and interview release forms, as needed, for the material in the collection. See Section D.2 in this chapter for information on release forms.
8. *May I accession objects expressly to use them in an exchange?* No. The park items you use in an exchange must be outside the SOCS. A park may not acquire objects outside the SOCS. In addition, acquiring objects to use in an exchange gives the impression that the park is dealing in collections. There would also be potential tax liabilities if the park acquired an object for the purpose of using it in an exchange. Refer to Section C.7 of Chapter 6, in this handbook, for information on tax liabilities.
9. *Who pays the transportation costs for an exchange?* Transportation costs are negotiable in an exchange. Usually the park pays transportation costs for the objects it is deaccessioning. You can modify Section 10 of the sample exchange agreement as needed for each exchange.
10. *What other types of documentation should I get for an exchange?* Get as much information as you can from the other party in the exchange. You may not be able to get this information later, and it is of primary importance for documenting the object. Don't be afraid to ask questions. If you don't get a response, document the fact that you asked.
- Note:** Keep the original accession documents for the material you deaccession. Provide the other party with copies of documentation needed to manage the objects.

L. Transfers

1. *What is a transfer?* When other parks or federal agencies transfer museum objects to your park, you accession the objects as a transfer. The other park or agency transfers title and control of the property to your park. Your park must agree to the transfer. Most transfers occur between parks.
2. *Who has the authority to accept transfers?* The park superintendent has the delegated authority to accept transfers from any federal agency.
3. *How do I document a transfer?* Document a transfer with a Transfer of Property, DI-104 (Figure 2.9). The park or agency that is transferring the objects completes the transfer form and makes two copies. The accountable officer for the other park or agency and the superintendent at your park sign both copies of the transfer. Keep one copy in the accession folder and return the other copy.
4. *Do I need an ownership statement for a transfer?* Yes. You don't necessarily need a signed statement as in Figure 2.6, but you do need copies of the accession or ownership documents. Ownership documents include such items as donor letters, previous transfers of property, and sales receipts. These documents provide a history of ownership for the objects you will accession. File this information in the accession folder.

If you receive a transfer from another park, there should also be a title verification statement on the transfer. Refer to Section L.2 in Chapter 6, in this handbook.

M. Transfer Considerations

1. *Does a transfer automatically include copyrights?*

No. You must have the other park or agency sign a transfer of copyright statement to get the copyrights.

A sample copyright statement appears in Figure 2.7.

You should make every effort to get all copyrights when receiving transfers of museum collections. Be aware that past transfers may not include copyrights.

Refer to Section E in this chapter for additional information on acquisitions and copyrights.
2. *How can I find out if other parks or agencies have material for transfer?*

Parks may advertise the need for objects:

 - on the curatorial bulletin board
 - on the Museum Management Program's web site
 - in the Clearinghouse Classifieds newsletter

Other federal agencies have newsletters, electronic bulletin boards, or web sites that may include lists of objects available for transfer. You may also advertise objects available for transfer using any of these options.
3. *What if I don't have a transfer form on file for previous accessions?*

All transfers should have a signed, original transfer of property form. Transfers that the park received before 1985 might not have a transfer form on file. Some early accessions may have very little documentation of any kind.

If you can determine that a previous accession was a transfer, try to get a signed transfer form from the other park or agency. Note the earlier date of transfer on the form. Document all your efforts to get a transfer form. Keep this documentation in the accession file.
4. *May I receive a transfer of NAGPRA material?*

Yes. However, you must have the consent of all affiliated Native American groups.

You must add the NAGPRA material that you acquire to the park's NAGPRA inventory or summary. Follow the guidelines in the *Cultural Resource Management Guideline*, Appendix R: NAGPRA Compliance.
5. *Are there special considerations for acquiring archival and manuscript collections through a transfer?*

Yes. Getting all copyrights is especially important for archival and manuscript collections. See Section E in this chapter for information on copyrights.

Be aware that archival collections may contain sensitive or legally-restricted material. You also need to be aware of the need to get model and interview release forms as needed for the material in the collection. See Section D.2 in this chapter for information on release forms.
6. *Who pays transportation costs for a transfer?*

Usually the receiving park pays the transportation costs for a transfer.
7. *What other types of*

documentation should I get for a transfer?

This includes accession records, catalog records, research notes, catalog folder contents, conservation records, and any other information available. The park or agency that is transferring the objects keeps the original documents.

N. Field Collections

1. *What is a field collection?*

Field collections are accessions of museum objects/specimens and field records that are park property. Most field collections are archeology or natural history collections. The authority for collecting objects or specimens is usually a permit or contract.

Accession resource management records as a field collection.

A park produces resource management records in the process of preserving its cultural and natural resources. These records document research, preservation, and restoration work and provide “baseline data” for ongoing management of resources. They include records and files that document resource management projects such as:

- ruins maintenance
- natural science inventories
- historical architecture research and maintenance
- cultural landscape research and maintenance

2. *How do I document a field collection?*

There is no transfer of ownership document for field collections, since the park has title to these collections. Use a Receipt for Property, Form DI-105 (Figure 2.1) to document receipt of material from authorized collectors. Print the name of the field collector and the project name on the receipt for property.

Don't issue a receipt for property if the collector doesn't bring the material to the museum. Some collections go directly from the field to a repository for analysis and storage. You'll need to accession the collection and place it on outgoing loan. Note on the Accession Receiving Report, Form 10-95 Rev. (Figure 2.2) that the park didn't receive the collection. Refer to Chapter 5, in this handbook, for information on outgoing loans.

Use the Accession Receiving Report, Form 10-95 Rev. (Figure 2.2) to document information about a field collection. It's important to get information from the collector to complete the report.

3. *What if I receive collections from a field collection over a period of time in more than one batch?*

You may receive more than one delivery of materials (objects/specimens, field records) from a single project. Issue a receipt for property for each delivery. You may assign a single accession number to the material if the project has the same:

- funding source
- project name
- geographic location

You must complete a receipt for property and update the accession receiving report and inventory for each delivery. Add the dates of additional deliveries and other pertinent information about each delivery in the Other Comments field in the ANCS+ accession record. This information will print in the Remarks section of the accession receiving report. Print a copy of the updated Accession Receiving Report, Form 10-95 Rev. (Figure 2.2) for each delivery. Store all copies of the accession receiving reports in the accession folder.

Note: For multi-year accessions, remember to make adjustments to your annual Collections Management Report (CMR). Adjust the number of items in the accession after the first year. Note that the adjustment is due to a multi-year accession.

4. *Can I accession field collections that are not at the park?*

Ideally, you should accession a field collection before it leaves the park. However, at times field collections are removed from a park before being accessioned. You must accession these collections as soon as possible. Contact the repository or collector for the information you will need to complete the accession records. Then give the repository or collector the accession information for the collection. It's not a good practice to assign accession numbers in advance.

Make sure you complete ANCS+ accession records for field collections that are not at the park. Provide accession information to the repository or collector who is cataloging the collection.

5. *What are field records?*

The term "field records" is sometimes used to describe the associated records that accompany the objects and specimens from an authorized collecting project, such as an archeological investigation. These associated records are a subset of resource management records. Field records include:

- field notes, journals, and diaries
- maps, graphs, and charts
- reports
- databases
- geographic information system records
- photographs, slides, and other documentary images of collecting localities, such as large scale aerial photographs

- correspondence
- audiotapes and videotapes

6. *Do I accession the field records when I accession a field collection?*

Yes. You must accession the field records along with the objects/specimens from a field collection. The permit or contract that authorizes the collection should state that all associated records are the property of the park.

The collector must provide a key to any abbreviations or codes.

Note: Collectors frequently keep their original field notes and give copies to the park. This is acceptable. For preservation purposes, it's a good idea to copy all paper field records onto archival paper.

7. *Do field records automatically include copyrights?*

The ownership of the copyrights depends on who created the records:

- When NPS or other federal staff produce field records while functioning in their official capacity as a government employee, the field records are in the public domain.
- Those who produce field records under contract own the copyrights to the records unless the contract states otherwise. The contract should state that:
 - the work (including field records) is a federal work-for-hire, meaning that the contractors have produced the records as part of their responsibilities, and therefore the records are in the public domain, *or*
 - the contractor transfers all intellectual property rights, including all copyrights and release forms, to the park
- Non-federal entities who produce field records under collecting permits own the copyrights to the field records they produce. Parks should try to get the copyrights whenever possible. A good way to do this is to state as a condition of the permit that field records (or copies) and the copyrights become park property.

Refer to the *MH-III*, Chapter 2: Legal Issues, for additional information about copyrights and federal contractors.

8. *Are there restrictions on field records?*

Yes. It is important to note restrictions at the time of accession. By law, you must place restrictions on the location data for:

- archeological excavations, including shipwrecks -- Archaeological Resources Protection Act (ARPA) of 1979 (16 USC 470)
- caves and cave resources – Federal Cave Resources Protection Act of 1988 (16 USC 4301-4309)
- historic resources at risk of harm, theft, or destruction – National Historic Preservation Act of 1966, as amended (16 USC 470-470t, 110)
- information concerning the nature and specific location of mineral or paleontological specimens or objects of cultural patrimony within units

NPS *Museum Handbook*, Part II (2000)

of the NPS or resources that are endangered, threatened, rare, or commercially valuable – National Parks Omnibus Management Act of 1998 (16 USC 5937)

You should also place restrictions on the following location data; however, these data may be subject to Freedom of Information Act (FOIA) requests.

- Indian sacred sites – Executive Order 13007—Indian Sacred Sites (May 24, 1996)
- nesting sites or specific habitat on threatened and endangered species – Endangered Species Act of 1973, as amended (16 USC 1531-1543)
- paleontological sites

Refer to the *MH-III*, Chapter 2: Legal Issues, for additional information about restrictions and FOIA requests.

9. *What if a field collection involves NAGPRA material?*

Authorized collectors must notify and consult with affected Native American groups about NAGPRA material before it is collected. When accessioning NAGPRA items, get as much information as possible from the collector. This is the most readily available evidence for determining cultural affiliation. Recording this information at the time of accession can make NAGPRA compliance much easier.

You must add the NAGPRA material that you acquire to the park's NAGPRA inventory or summary. Follow the guidelines in the *Cultural Resource Management Guideline*, Appendix R: NAGPRA Compliance.

O. Other Field Collections

1. *What is an unauthorized field collection?*

An unauthorized field collection may occur if an individual collects objects/specimens in the park without a permit or contract. For example, visitors may occasionally turn in objects that they have found in the park.

NPS policies prohibit unauthorized collecting. Strongly discourage this type of accession. Consider returning the objects to their original location, if possible.

Parks may want to establish a Standard Operating Procedure (SOP) for how to handle unauthorized collecting.

2. *How do I document an unauthorized field collection?*

If you have to accession an unauthorized field collection, record it as a field collection. Use the Accession Receiving Report, Form 10-95 Rev. (Figure 2.2) to record the:

- details of the collection location
- finder's name and address
- name of the staff member who received the material
- any other details that relate to the material or its collection

List the park as the source of accession on the report. Don't issue a receipt for property for an unauthorized field collection.

3. *Do I accession objects that were manufactured in the park as a field collection?*

Yes. Park staff, contractors, or cultural demonstrators may make objects in the park that become part of the museum collection. Accession these objects as a field collection. Have the maker sign a statement that he or she produced the objects while working for the park. Get as much information as possible from the maker about the object. File this information in the accession folder.

4. *Do I accession objects without accession documentation as a field collection?*

Yes. If you are unable to find any documentation to tell how the park acquired the objects, accession the objects as a field collection. Many parks have material from unknown sources in the park museum collection. You may find undocumented material in the collection or in other storage areas of the park.

It may not always be easy to determine whether objects that you find without accession documentation are museum material. The objects should fit within the park's SOCS, or relate in some way to other material in the collection. When in doubt, consult other park staff or your regional/SO curator.

Note: If you find out the source of the material at a later date, change the accession information. See Section V.14 for information about changing accession type.

5. *How can I make sure the documentation for an accession is really missing?*

Do a thorough and organized search for the missing documentation. Record everything that you know about the objects and the source of that information. You may want to create a checklist to record the steps you take and the information you find. Some questions to ask include:

- Does the location in which you found the material supply information?
- Can other staff give you information?
- Can you locate former staff and interview them?
- Has someone labeled the material incorrectly?
- Is the material actually part of another accession?

If there is evidence of a source of accession, try to locate the other party to get a transfer of ownership document. Refer to Section B.11 of this chapter.

Be sure to document the sources you contact and the information you find, even if it's negative or inconclusive. Distinguish facts from theories or assumptions. Thorough records can prevent later duplications of effort and add to the interpretive value and history of the collection.

Note: Searching for missing accession documentation can be time-consuming and complex. You often don't get any clear-cut answers or solutions. You may want to consult with your regional/SO curator before conducting a search.

6. *How do I accession objects that don't have documentation?*

Enter only the known facts about the accession in the accession book. Use the date of entry in the accession book as the acquisition date. This is the date that the park acknowledged custody of the objects. The source of

accession for collections without documentation is the National Park Service or “Unknown.”

Complete an Accession Receiving Report, Form 10-95 Rev. (Figure 2.2) for the accession. In the Remarks field, describe how and where the material was found and who found it. If you’ve done research on the accession, include a working hypothesis on the source of the material. List the sources you used, including the names and addresses of people you interviewed.

Include your research notes and documentation in the accession folder. Make sure that the accession folder contains all the information that you know about the objects.

7. *Does the park own the copyrights on materials found in the collection?*

The park can’t assume that it owns the copyrights on materials that are found in the collection without accession documentation. Refer to the *MH-III*, Chapter 2: Legal Issues, for information on what types of materials are protected by copyright.

P. Incoming Loans

1. *What is an incoming loan?*

Museum collections for which you have temporary custody are incoming loans. There is no transfer of ownership with an incoming loan. The lender is the owner of the property. The park or NPS center is the custodian of the property for a specific period of time. Parks receive incoming loans from other parks, institutions, or individuals. NPS centers receive incoming loans from parks. The NPS treats incoming loans as accessions.

Note: Museum collections that are at a park for less than 30 days are not incoming loans. Issue a Receipt for Property, DI-105 (Figure 2.1) when you receive objects for less than 30 days. Note on the receipt the date that the owner must get the property. Include the owner’s name, address, and phone number on the receipt. File and track the receipt by the date of return. If you decide to keep the objects for more than 30 days, you must complete an Incoming Loan Agreement, Form 10-98 Rev. (Figure 2.11).

2. *Why does the NPS accession incoming loans?*

The NPS uses the accession number as the incoming loan number to avoid an additional numbering system. Accessioning incoming loans also provides these objects with the same accountability system that you use for the collections that the park owns.

You must accession all incoming loans. Follow the procedures in Sections U and V of this chapter.

3. *For what purposes may I borrow museum objects?*

Parks usually borrow museum objects for exhibition or research. You may borrow museum objects for any reason consistent with the purposes of the park.

Note: In general, it doesn't benefit the park to have objects in your collection that you don't own. Limit incoming loans to objects you need for very specific purposes, such as a temporary exhibit.

4. *Must the objects I borrow fit within the park's SOCS?*

No. Objects that you borrow for short-term exhibits and research don't need to fit within the park's SOCS. Objects that you borrow for periods of over a year should fit within the SOCS.

5. *How do I document a loan?*

You must use the Incoming Loan Agreement, Form 10-98 Rev. (Figure 2.11) to document loans to the NPS. As part of the accessioning process complete an incoming loan agreement that lists the objects in the loan. The incoming loan agreement is a formal, legal agreement that transfers custody for a specific period of time.

Refer to Section R of this chapter for additional information on the incoming loan agreement.

6. *For how long may I borrow museum objects?*

Limit the length of incoming loans to three years. You can extend the loan after three years if needed. NPS centers should review and extend incoming loans from parks every ten years.

7. *Must I catalog incoming loans?*

Yes, if you keep them for over a year. You don't have to catalog incoming loans that you keep for less than one year. Cataloging is usually part of the purpose for incoming loans to NPS centers.

Note: Don't mark the objects with a catalog number. Tag incoming loans with the catalog number.

8. *Who makes the loan?*

As the staff person responsible for the museum collection, you must review all potential loans and make recommendations to the superintendent.

The superintendent approves or disapproves all incoming loans.

Once the superintendent approves the loan, you're responsible for processing, documenting, and tracking the loan.

Q. Incoming Loan Considerations

1. *May I make third-party loans?*

No. The NPS doesn't permit third-party loans. You may not loan out material that you acquired as an incoming loan.

Note: Parks may grant NPS centers blanket approval to make third-party loans for routine conservation, exhibit, or analysis.

2. *Are there special procedures for loans between parks?*

Yes. The incoming loan agreement is optional if you receive a loan from another park. The lending park must follow the procedures in Chapter 5: Outgoing Loans, of this handbook.

If your park is the borrower:

- treat the loan as an incoming loan
- use the lending park's outgoing loan agreement in place of an incoming loan agreement
- follow all other incoming documentation procedures as outlined in this chapter
- place the accession number you assign to the incoming loan on the lender's outgoing loan form

Note: For CMR and tracking purposes, you must enter the incoming loan into the Loans In associated module of ANCS+. If you want to have an incoming loan agreement, you can print one from this module.

3. *Are there special procedures for loans between parks and NPS centers?*

Yes. The lending park must follow the procedures in Chapter 5: Outgoing Loans, in this handbook. Refer to Section F of Chapter 5 for special procedures for lending objects to centers.

The NPS center may:

- use the lending park's outgoing loan agreement in place of an incoming loan agreement, *or*
- complete an incoming loan agreement for the park

4. *Must I inventory incoming loans?*

Yes. Incoming loans are controlled property that you must include in the annual inventory. When you catalog incoming loans, enter a "Y" in the Controlled Property field. You must inventory all controlled property annually. Refer to Section I of Chapter 4 in this handbook for instructions on completing a controlled property inventory.

NPS centers don't treat incoming loans from parks as controlled property. Centers inventory individual objects within the loan that meet controlled property criteria.

Note: You must make incoming loans available for the lender to inventory, as needed. The lender may ask you to verify in writing or by phone the presence and condition of objects.

5. *Are incoming loans subject to NPS collections management policies?*

Yes. Objects on incoming loan are subject to NPS museum management policies. Incoming loans appear on the annual Collections Management Report (CMR). Refer to Section VIII of Chapter 4 in this handbook for information on the CMR.

6. *Where do I get the forms for incoming loans?*

Use ANCS+ to print blank or completed incoming loan forms. Use acid-free paper to print the forms.

Acid-free paper is available from the Supply and Equipment Program of the

Museum Management Program, National Center for Cultural Resources.

7. *Does an incoming loan include copyrights?*

No. Incoming loans don't include copyrights. Copyrights for material on loan stay with the owner of the material. As a condition of the loan, you may negotiate permission to use the materials for special purposes, such as park publications and exhibitions.

R. Processing and Documenting Incoming Loans

You are responsible for processing and documenting the loan transaction. For an overall view of the loan process, refer to Flow Chart Figure 2.14.

1. *Loan Identification and Review*

You or other park staff, such as exhibit specialists or interpreters, may identify objects you want to acquire on loan. If your park has a collections advisory committee, have them review the potential loan. You may also want to consult with the regional/SO curator before negotiating the loan.

Refer to Section B.8 of this chapter for information on the collections advisory committee.

2. *Loan Requests*

Request and arrange loans in advance. You should send a formal letter of request from the superintendent. You and the lender must agree to the terms of the loan. The lender may send you a sample loan agreement and conditions. You may want to send the lender a copy of the Incoming Loan Agreement, Form 10-98 Rev. (Figure 2.11) and Conditions for Incoming Loans, Form 10-98a Rev. (Figure 2.12) for review.

Before approving the loan, the lender may request that you complete a facility report. A facility report provides the lender with written evidence that the park can adequately care for the loan. You can get a facility report from the American Association of Museums or the NPS Museum Management Program.

3. *Insurance*

Non-federal museums, private owners, and state or local agencies may require insurance coverage as a condition for a loan. As the borrower, you're responsible for paying for the insurance. You don't need insurance for loans from other parks or from most other federal agencies. The agency will tell you if you need to purchase insurance.

Refer to Section VII of Chapter 4 in this handbook for information on purchasing insurance.

4. *Shipping*

As the borrower, you are responsible for arranging the shipping with the lender's approval. You pay all the shipping costs. You may negotiate to have the lender arrange for shipping and charge the shipping costs to you.

Unless otherwise agreed to in writing, parks are responsible for shipping arrangements and costs for incoming loans to NPS centers.

Refer to *MH-I*, Chapter 6: Handling, Packing and Shipping Museum Objects.

5. *Loan Agreement*

The lender should send you two copies of the lending institution's loan agreement that contains the conditions of the loan. Have your superintendent sign both copies of the agreement, and return one copy to the lender. You must also complete an Incoming Loan Agreement, Form 10-

98 Rev. (Figure 2.11) for all incoming loans. You cannot substitute a non-NPS form for Form 10-98. The loan agreement includes:

- the purpose for the loan
- starting and ending dates
- address and contact names for both parties
- the objects in the loan
- a credit line
- shipping and packing information
- insurance coverage information
- specific conditions concerning the loan

You can print a completed incoming loan agreement by using the Loans In associated module in ANCS+. Refer to the ANCS+ User Manual for instructions. Print the form on acid-free paper.

Note: See Figure 2.10 for instructions on completing and sending the incoming loan agreement.

6. *Attachments to the Loan Agreement*

Attach a list of objects and the conditions for the loan to the loan agreement.

List of Objects

For large loans, attach a list of objects to the loan agreement. You may attach:

- a copy of the lender's list of objects with the lender's catalog numbers, if appropriate
- a copy of the ANCS+ accession receiving report continuation sheet that includes a list of objects in the accession
- an inventory list or computerized list that you create

Note: After you catalog the objects in the loan, you can complete the List of Objects, Form 10-417 (Figure 2.14) using ANCS+. Attach this form to the incoming loan agreement.

The list of objects in the loan should include:

- object name
- brief description
- item count or quantity
- condition
- value (if appropriate)

- space for comment

Conditions

Attach the Conditions for Incoming Loans, Form 10-98a Rev. (Figure 2.12) to the incoming loan agreement. If additional conditions are necessary, note them in the additional loan condition section of the incoming loan agreement.

7. *Signing the Loan Agreement*

Your superintendent and the lending official are responsible for meeting the terms of the loan agreement.

Your superintendent signs two copies of the incoming loan agreement and sends them to the lender. The lender signs both copies, returns one copy to the park, and keeps the other copy.

For incoming loans to NPS centers, the center manager must sign the loan agreement.

8. *Filing the Loan*

Store all the documents for the loan in the accession folder. Refer to Section V of this chapter for information on the accession folder.

9. *Receiving the Objects*

When you receive an incoming loan:

- Give the objects time to acclimatize before unpacking.
- Unpack and inspect the objects.
 - photograph packing techniques for awkward or fragile objects to help you when repacking
 - photograph poor packing to document to the lender that the park is not responsible for shipping damage
 - save and reuse the packing materials (if professionally or well-packed) for return of the loan.
- Document the condition of the objects. Photograph any objects that were damaged in shipment. Notify the owner and insurance company immediately, if necessary.

<i>If the lender...</i>	<i>Then...</i>
has completed an object condition report,	note any changes or “no change,” date, and sign the report.
hasn't completed an object condition report,	you may want to complete one to protect the park from possible disputes over object condition.

- Record the loan in the accession book (refer to Section U of this chapter for information on the accession book).
- Complete an Accession Receiving Report, Form 10-95 Rev. (Figure 2.2), and create an accession folder. Refer to Section V of this chapter for information on documenting accessions.
- Tag the objects with NPS accession numbers.
- Send a memo or e-mail message to the lender to acknowledge receipt of the objects. Keep a copy in the accession folder.

Note: ANCS+ will print an Object Condition Report, Form 10-637 from the condition information you enter on the catalog record.

S. Tracking Incoming Loans

You are responsible for tracking all incoming loans. Keep up-to-date loan agreements for all incoming loans.

1. *ANCS+ Loans In Associated Module*

Use ANCS+ to track incoming loans by return date. By entering your incoming loans into ANCS+, you can print all the loan forms and sort and track your loans by return date. ANCS+ contains all the required fields for loan data.

Refer to Section V of Chapter 4 in the *ANCS+ User Manual* for information on using the Loans In associated module.

Note: NPS centers may use a customized version of the ANCS+ Loans In associated module to track incoming loans.

2. *Monitoring and Recall*

All incoming loans, with the exception of incoming loans to NPS centers, should include a regular monitoring schedule. Conducting an annual inventory of controlled property is sufficient monitoring for most loans. You may need to monitor certain objects, such as those on exhibit, more frequently.

You should give at least 30 days written notice to cancel a loan before the termination date. Most lenders reserve the right to end a loan within 30 days written notice.

3. *Loan Extensions*

The lender will usually tell you when a loan is coming due. If you don't

hear from the lender, it is your responsibility to contact the lender.

You may request a loan extension. Give an extension a specific ending date, not to exceed three years. NPS centers can extend incoming loans for up to ten years.

The lender may ask you to update a facility report when negotiating a loan extension. You will also have to extend insurance coverage, if applicable. Provide the lender with a copy of the certificate of insurance for the extension period.

The lender may extend the loan with a loan extension form, letter, or new loan agreement. Review the extension document and have the superintendent sign and return it to the lender. Keep a copy with the original loan agreement. If the lender extends the loan by letter, have the superintendent send a written acknowledgment of the extension. Include the new ending date for the loan in the acknowledgment.

Update the Incoming Loan Agreement, Form 10-98 Rev. (Figure 2.11) with the new extension date and any new loan conditions. Don't create a new incoming loan agreement. Send a copy of the updated agreement to the lender. File all loan extension documentation in the accession folder.

4. *Loan Termination*

Before the termination date of the incoming loan, make arrangements for shipping and packing the objects. You, as the borrower, are responsible for shipping and packing costs.

Pack objects using the same packing methods as the lender. If the objects were poorly packed, refer to *MH-I*, Chapter 6, Handling, Packing, and Shipping Museum Objects. Consult with the lender if you change the packing.

Make sure the lender receives the objects. Contact the lender to verify receipt.

Send a letter requesting the lender to sign the original incoming loan agreement and return it to the park. Keep the signed, terminated loan agreement and all other documentation on the loan in the accession file.

5. *Documenting a Loan Return*

To document the return of an incoming loan:

- Note the return of the loan in the accession book in the Remarks column.
- Note the return of the loan on all other accession documents, including the accession receiving report.
- Enter "Returned" in the Status field in the ANCS+ Loans In associated module.
- Enter "Deaccessioned" in the Catalog Status field on the ANCS+ accession record.
- Enter "Deaccessioned-Loan Returned" in the Object Status field on the catalog records for the objects in the loan.

- Change the Location field on the catalog records for the objects in the loan. Note that the loan was returned.
- Change the Controlled Property field to “N” on the catalog records for the objects in the loan.

Don't use the ANCS+ Deaccessions associated module for the return of incoming loans. Use this module only when the park owns an item and is giving up ownership. The NPS uses the term “deaccessioned” for the return of incoming loans because the loan has been accessioned. The return of a loan is a type of deaccession, but it involves a change of custody, not ownership.

Note: The return of incoming loans appears in the deaccession section of the Collections Management Report (CMR).

T. Old Loans

1. *What is an old loan?*

The curatorial staff at many parks face the problem of old loans. Old loans may be:

- loans that have expired, and you cannot locate the owner
- long-term loans without a termination date that the lender hasn't claimed
- partially or undocumented loans

Note: There is generally some form of documentation, such as a letter, that lets you know that you're dealing with a loan. Refer to Section N of this chapter for information on accessioning objects that you find in the collection without any documentation.

To avoid the problem of unclaimed loans in the future, attach the Conditions for Incoming Loans, Form 10-98a Rev. (Figure 2.12) to the loan agreement. The conditions include procedures the NPS will follow for unclaimed loans.

2. *Why is it important to resolve old loans?*

The resolution of old loans should be a high priority. Without legal title, you have limited use of these collections, but you must pay the costs of storing and caring for them. The longer you wait, the harder it may be to find the legal owner.

3. *How do I go about resolving an old loan?*

First you must know the location and condition of the object and what the park wants to do with it.

Many states have enacted old loan laws. Refer to Figure 2.15 for a listing of state laws. If your park is in one of these states, follow the procedures for your state.

If your state hasn't enacted old loan legislation, follow the procedures in Sections T.4-T.8 below. Consult your regional/SO curator and regional solicitor.

4. *How should I contact the NPS Museum Handbook, Part II (2000)*

Send a notice of termination in a certified letter, return receipt requested, to

lender?

the last known address of the lender. The letter should include the following information:

- the date of notice
- the name of the lender
- a description or list of the object(s) in the loan
- the dates of the original loan
- your name, address, and telephone number for contacting you at the park
- a statement that the museum wants to terminate the loan and return the objects
- a request for the lender to contact you within 45 days
- a statement that the park will take title to the objects within one year of the date of the notice if the lender doesn't contact the park

<i>If...</i>	<i>Then...</i>
you hear from the lender,	terminate the loan or have it converted to a permanent accession, such as a gift.
you don't hear from the lender,	conduct a reasonable search for the owner, heirs, or designees.

5. *What should I do to locate a missing lender?*

You must make a reasonable effort to locate the lender. Be sure to document the steps you take. Your efforts may become evidence if the owner or heirs resurface at a later date and demand the return of the property. Some sources to search include:

- telephone directories
- relatives
- real estate records
- probate records
- vital (death) records
- Web-based national phone directories

During your search for the lender, you may discover that he/she has died. You must then conduct a reasonable search for the lender's heirs. Contact the heirs with a certified letter.

If you are able to locate the lender, heirs, or designees follow the procedures in Section T.4 above.

Note: Searching for missing lenders takes time and effort. You must determine what is a reasonable search given the particular circumstances of each loan.

6. *What if I'm unable to locate the lender or legal owner?*

If you can't locate the owner of the objects, you must publish a notice of intent to terminate the loan. Publish the notice in a newspaper of general circulation in the local area of the:

- last known address of the lender, *and*
- park (if different from the lender's address)

Publish the notice twice, 60 or more days apart. The one-year waiting period begins with the second publication.

Address the notice to anyone claiming ownership or other legal interest in the property. The notice should include the same information as the certified letter to the lender. Refer to Section T.4 above. For example:

Second notice to Mr. Jackson B. Smith last of 346 Persimmon Lane, Lancaster, PA. On 8/19/1985 you loaned a miniature painting in a wooden and brass frame to Park National Park. This loan expired 8/19/1988. The park wants to terminate the loan and return the object. Please contact Tom Brown at [park address and telephone number] within 45 days of this notice. The park will take title to the objects within one year of this notice (4/5/2001) if you do not contact the park and make arrangements to terminate the loan. (4/5/2000)

7. *What if someone other than the lender claims to own the property?*

Don't give the property to anyone without proof of ownership. Get enough documentation to prove that the person or institution is the legal owner or authorized representative of the owner.

In the case of an heir or heirs, request a copy of the lender's will. If no will exists, contact a solicitor.

8. *What if more than one person claims to be the owner of the property?*

Don't release the property if there are competing claims of ownership. Wait to release the property until the parties reach an agreement or a court action resolves the dispute.

9. *Does the park own the copyright on materials in unclaimed loans?*

No. The park doesn't own the copyrights on materials in an unclaimed loan. Refer to *MH-III*, Chapter 2: Legal Issues, for information on what types of materials are protected by copyright.

10. *What do I do if the loan remains unclaimed?* If you follow the notification procedures in this section and the loan remains unclaimed, accession the object as a gift. Note the circumstances of the unclaimed loan on the Accession Receiving Report, Form 10-95 Rev. (Figure 2.2) File all the documentation on your search for the lender in the accession file. Don't use a deed of gift form.
- See Section V.14 for procedures for changing accession type.
11. *May I deaccession objects from unclaimed loans?* Yes. If you follow the notification procedures in this section, you may deaccession the objects from unclaimed loans. Be sure to maintain all documentation on your search for the lender. Refer to Chapter 6 in this handbook for deaccessioning procedures.
12. *What do I do if the owner comes forward after I accession the unclaimed loan as a gift?* If you follow the notification procedures in this section, and the loan remains unclaimed, it becomes abandoned property to the United States. You don't have to return the material at this point. However, with a solicitor's written opinion, the park may choose to deaccession the material to the original owner. Use the deaccession type "Return to Rightful Owner." Refer to Chapter 6 in this handbook for information on deaccessioning.

U. Accession Book

1. *What is the accession book?* The Accession Book, Form 10-256 (Figure 2.16) documents the source for **every** object in the park's museum collection. It contains the sequential log of transactions that prove NPS ownership of museum collections and temporary custody for incoming loans. All material in the park's museum collection must be part of an accession in the accession book. You haven't officially accessioned the material until you enter the accession in the accession book.
- Treat your accession book as a legal document. It may be used in a court of law, if necessary. The value of the book as a legal document lies in the uninterrupted sequence of entries, without missing pages or erasures.
- The accession book is one of your most important museum record-keeping documents. It is designed for permanence. The pages are made of high-quality rag paper. Each page is string-bound into a hard cover. New accession books are available from the Supply and Equipment Program of the Museum Management Program, National Center for Cultural Resources.
2. *May a park have more than one accession book?* No. You may have only one accession book, or set of books, with one series of accession numbers.
- Note:** If the park contains different management units in different geographical locations, you may need an accession book for each unit. Consult your regional or support curator. You must submit a written request to keep an accession book at each geographical unit. Submit the request to the Chief Curator, Museum Management Program, National Center for Cultural Resources.
3. *Should I store the accession book in a special place?* Yes. You must store your accession book in a secure room in an insulated file cabinet with a lock. Monitor and control access to the accession book.
4. *Should I make a copy of the accession book?* Yes. Make an archival photocopy or microform copy of the original accession book. Store the copy in a different location from the original.

Making a copy of your accession book helps to safeguard against loss and potential fraud or abuse.

5. *How do I make an entry in the accession book?*

Be extremely careful when making entries in the accession book. Making a draft entry on plain paper may help you avoid errors. When you make entries:

- Print neatly.
- Use high quality permanent black carbon (India) ink with fountain, quill, or rapidograph pen, or a fine felt-tip permanent ink pen (pigment ink pen).
- Check to make sure the entry is accurate.

Note: Pens and ink are available from the *Tools of the Trade* catalog.

Entries in the accession book should be chronological. Make entries upon receipt of the objects.

Complete the columns in the accession book as follows:

Accession Number

Record the number for the accession. The accession number is a unique number that allows you to connect the objects in an accession to the documentation. Use one number for each accession transaction. Some accessions may contain one object; others may contain thousands of objects.

Don't repeat or reuse accession numbers.

Don't use decimals in the accession number. The NPS accession number is in a three-part format:

- The first part is the four-letter park acronym, in the form of "AAAA."
- The second part is a hyphen, which distinguishes the accession number from the catalog number.

A few parks will use a collection designation letter, such as A, B, C, in place of the hyphen. Use a collection designation letter only if your park has approved separate accession and catalog systems under one acronym.

The Chief Curator must approve the designation. Review requests to use a designation with your regional/SO curator. Submit a written request to the Chief Curator, Museum Management Program, National Center for Cultural Resources.

- The third part is the sequential, identification number that you assign to an accession.

Example: DETO-678

Date Received

Record the date that you acquired the material for the museum collection. For gifts, exchanges, transfers, and incoming loans, both the owner and the superintendent must sign the transfer of ownership document or incoming loan agreement. The acquisition date is the later date of these two signatures. This is the date that you completed the transaction and the material became part of the museum collection.

Note: It's important to get a signed transfer of ownership (deed of gift, exchange agreement, transfer of property) or incoming loan agreement before, or at the time, you receive the objects. The park doesn't legally own the objects until both the superintendent and the other party have signed a transfer of ownership document.

For purchases, enter the date of the sale. For field collections, enter the date you received the objects. For field collections that won't remain at the park, enter the date you completed the Accession Receiving Report, Form 10-95 Rev. (Figure 2.2). If you receive field collections from the same project on different dates, use the first date of receipt as the acquisition date.

The date you enter in the accession book will become the date of accession.

Enter the date in standard format using the full year. You can abbreviate the month.

Example: Nov 3, 1997

Dates before 1985 may have been entered without a day and month, such as pre1957, or in other formats. Don't reformat earlier dates. If you now know the correct date, add it as a correction to the date field. Don't remove the previous date.

Use the date of entry in the accession book as the acquisition date for old accessions that haven't been entered into the accession book. In the Remarks column, note the earlier date when the objects were received at the park, if known.

Description

Briefly describe and quantify the material in the accession. Use general terms. The accession book has limited space. You won't be able to list all the objects in a large accession. Include a complete inventory or list of objects with the accession receiving report. If applicable, provide the project name and state site number.

Examples: 7 Civil War uniforms and accoutrements
103 boxes of excavated material from the Hill Site (36CR1947)
Project 116 Prehistoric Occupations and associated field records
125 botanical specimens
one oil painting "Grand Canyon at Dawn" by Thomas Moran

Received From

Record the full name (last name first), address, and telephone number of the source of the accession. The source of accession is the previous owner of the material. If the source of accession is an institution, include the name of the responsible official or contact person. Enter the responsible official's name after the name and address of the institution.

The source of accession for field collections is the National Park Service. Enter the name of the collector as the individual representing the National

Park Service. If the collector is an NPS employee, include his or her title.

How Acquired

Record the type of accession. Use only the following accession types:

- gift
- purchase
- exchange
- transfer
- field collection
- incoming loan

Remarks

Record comments about the accession, as needed. Make sure the documentation in the accession folder supports the remarks. Don't enter transitory notes, such as "Consider for deaccession?"

Example: Returned to lender June 5, 1991.
Loss or theft, March 1991.
Received at park in early 1960s.

Catalog Numbers

For small accessions, record the catalog numbers for the objects in the accession, after you catalog the accession. Including the catalog numbers in the accession book provides a good cross-reference between the accession and catalog records.

For large accessions, leave this column blank. Include the catalog numbers on the list of objects that you attach to the accession receiving report.

6. *How do I make corrections to the accession book?*

If an accession entry contains a mistake, draw a single line through the incorrect information. Enter the correct information above or below or on another line. Initial and date the correction. Clearly enter your signature in the Remarks column.

Never erase or blot out the entries in the accession book. Don't use correction fluid or correction tape.

7. *What if I find that an object is in the wrong accession?*

Record the object in the correct accession, and note the correction as in Section U.6 above. Cross-reference to the incorrect accession.

8. *How do I correct an entire accession book page?*

In extreme cases, you may have to rewrite whole pages of an accession book. Consult your regional/SO curator if you need to do this.

Never remove pages from the accession book.

Draw a single diagonal line from the upper left corner to the lower right corner of the page you want to delete. Write your signature and date on the line. Record the corrected entries on the next page. If you can't use the next page, include a note on the deleted page about the location of the corrected entries.

9. *What if I need to recopy the entire accession book?*

In general, you should never recopy your accession book. Consult your regional/SO curator if you think you need to recopy your entire accession book. A "messy" accession book is not a valid reason for recopying the book. You must receive written permission to recopy the book. Consult your regional or system office curator before sending a request. Send your request to the Chief Curator, Museum Management Program, National Center for Cultural Resources.

File the request and its response with the accession book. If you receive permission to recopy the book, keep the old accession book with the accession files.

You may need to recopy the entire book if:

- pages are ripping and tearing due to brittleness or mishandling
- there is severe ink fading
- pages are severely distorted, cockle, or buckled
- it contains mold
- it is contaminated with chemical, biological residue, radiation, or asbestos that can't be mitigated
- there is insect or vermin residue
 - it is stained from leaks or spills

Consult a conservator about problems like these before requesting to recopy the book. With conservation treatment, you may be able to continue to use the book. Refer to *Conserve O Gram (COG) 1/5, Salvaging Acidic or Damaged Museum Accession Books*.

10. *What if I need to rebind the accession book?*

You may need to rebind your accession book if the pages are coming loose or the spine is coming off. Make a complete photocopy before sending it out for rebinding. Number each page on both sides if both sides are used. Take care not to damage the original volume. Refer to *COG 19/7*, Archives: Reference Photocopying, for instructions on making a high quality copy. To locate a reputable binder, contact the regional/SO curator or the conservator for the Museum Management Program.

If the accession book is too fragile for reference use, carefully photocopy it and place the copy in an archival-quality three-hole binder album. Number each page on both sides if both sides have entries. Use the copy for reference. Purchase an archival book box or slipcase to help store the original book. Use the original only to enter new accessions. Make photocopies of the new accessions as needed. If the original book is too fragile for new entries, order a new book.

11. *Should I replace or deacidify my accession book if it is acidic?*

No. Many NPS museum accession books may border on the acidic. However, under cool, dry storage conditions, acidic paper may last a long time. If you store and handle your accession book correctly, it will last many more decades.

Consult a conservator if you are concerned about the acidity of your accession book. Deacidification isn't the answer to all acidic paper concerns. For example, it doesn't make paper less brittle. Some chemicals used in deacidification may change the appearance of inks, eventually causing fading and information loss. Deacidification also needs to be an ongoing series of treatments. The calcium carbonate buffering that the process uses depletes over time.

V. Documenting Accessions

You are responsible for documenting the accession transaction and maintaining all the original documentation. Accession records should be as accurate and complete as possible. For an overall view of the accessioning process, refer to Flow Chart Figure 2.17.

Before documenting an acquisition, you must have a transfer of ownership document or an incoming loan agreement. Refer to the appropriate section of this chapter for the document to use with each accession type. Section F for gifts, Section H for purchases, Section J for exchanges, Section L for transfers, Sections N and O for field collections, and Section P for incoming loans.

1. *Receipt of Objects*

When you receive an accession:

- Give the objects time to acclimate before unpacking.
- Unpack and inspect the material as soon as possible. Do this outside the museum storage area.
- Inspect objects for potential insect infestation, mold, vermin, asbestos,

nitrate and other health and safety hazards. Isolate infested or unsafe materials immediately to avoid contaminating other material. Stabilize the collections after consulting with a conservator. Refer to the *MH-I*, Chapter 5, Biological Infestations, and the *COG* series for information on collection hazards.

- Check that the material corresponds to written descriptions on the transfer of ownership document. Refer to Section R of this chapter for information on receiving incoming loans.

2. Accession Receiving Report

You must complete an Accession Receiving Report, Form 10-95Rev. (Figure 2.2) for all accessions. The report documents the receipt of the material and information from the source of accession.

Note: You must have an accession receiving report on file for all accessions dating from 1985. Completing an accession receiving report for accessions prior to 1985 is optional.

To complete the accession receiving report, you must first enter the accession into ANCS+. Refer to Chapter 4 of the *ANCS+ User Manual* for instructions on entering accessions into ANCS+. Section V.5 of this chapter contains a list of the fields in the ANCS+ Accession Records associated module.

Complete the accession receiving report with information from the source of the accession. Get as much information as you can. You may not be able to get this information later. It is of primary importance for documenting the material in the accession and can greatly assist you in cataloging the objects.

Don't be afraid to ask questions. Find out how the owner acquired the objects. Ask the owner questions about the use, manufacture, and significance of the objects. Document your findings.

For field collections, note whether the field records are included, or not included, in the accession. Record:

- permit number
- project title and dates
- principal investigator (name and address)
- state site number for archeological collections (you may have to add later when assigned)
- precise locations of the collecting activity, including geographic coordinates (site name or descriptive title for a survey that includes many sites)
- site and field numbers (see above for surveys)
- information about releases
- restrictions or sensitivities

- information on informed consent

File the accession receiving report in the accession folder. Refer to Section V.8 of this chapter for information on the accession folder.

The designated receiving officer signs the accession receiving report.

3. *Recording Condition*

It's important to record the condition of the material upon arrival. Record the overall condition of the accession on the accession receiving report. Record specific object condition on the list of objects that accompanies the accession receiving report. Photographing objects is a good way to record physical condition.

Note: ANCS+ will print an Object Condition Report, Form 10-637 from the condition information you enter on the catalog record.

4. *List of Objects*

You must attach a list of objects to the accession receiving report. You can:

- enter the list in ANCS+ and print it on the Accession Receiving Report (Continued), Form 10-95 Rev.
- use a copy of the itemized list that was attached to the transfer of ownership document
- attach a field level inventory, field specimen, or provenience log for field collections
- attach a list that already exists in another format

Note: After you catalog the objects in the accession, include the catalog numbers on the list of objects.

For small accessions of one to six objects (not more than six lines), the list of objects will print on the accession receiving report.

5. *ANCS+ Accession Records*

You must enter all accessions into the ANCS+ Accession Records associated module. Refer to Section I of Chapter 4 in the *ANCS+ User Manual* for instructions on using the module. You may enter data directly into the program or use the accession worksheet that came with the manual.

Using ANCS+, you can complete and print the:

- Accession Receiving Report, Form 10-95 Rev. (Figure 2.2)
- Deed of Gift, Form 10-830 Rev. (Figure 2.3)
- source of accession card
- Accession Folder Cover Sheet, Form 10-255 Rev. (Figure 2.18)

Make sure that the entries in the ANCS+ accession record match the entries in the accession book.

The ANCS+ accession record includes all the fields you will need to track the accession. The fields include:

Accession Number
Acquisition Type
Acquisition Date
Catalog Status
Region
Cultural Resources Totals (by discipline)
Natural History Totals (by discipline)
Item Total
Source Individual
Source Institution
Source Official
Description
Related Accessions
Condition
Other Comments
Custody Document
Publication
Permit Number
State Site Number
Phase Type
Project Date
Project Title
Project Director

You must submit electronic copies of accession records along with your annual catalog record submission to the National Catalog.

6. *Accession Book*

Make an entry in the accession book. Refer to Section U of this chapter for information about the accession book.

7. *Tagging and Storing Objects*

Tag objects with the accession number. Use acid-free tags without metal rims. Don't use adhesive or pressure sensitive tapes or apply labels directly to objects. Refer to the *Tools of the Trade* catalog for ordering acid-free tags.

Store the tagged objects in an accession storage area until you can catalog them.

Note: If objects are too small to tag individually, tag or label the containers.

8. *Accession Folder*

Create an accession folder to store all the paperwork for the accession. Using ANCS+, print an Accession Folder Cover Sheet, Form 10-255 Rev. (Figure 2.18). The sheet contains a checklist that shows you the documents in the folder. Place the cover sheet inside the front cover of the folder.

Note: You can complete the cover sheet manually or on the computer.

You must have an accession folder for every accession.

Each accession folder contains the originals or archival copies of the documentation that supports the accession. The documentation must correspond with the accession book entry.

For example, if...

The entry in the accession book is for a transfer,

Then...

the accession folder should contain a transfer of property form.

The accession folder is an archival file folder. Write the accession number on the folder tab using permanent black carbon ink. Use a fountain, quill or rapidograph pen, or a fine felt-tip permanent ink pen (pigma ink pen). Don't use pressure-sensitive tapes that can fall off in time.

Folders, ink, and pens are available through the *Tools of the Trade* catalog.

Mark the accession number in permanent ink in the upper right corner of all the accession documents in the folder.

Note: You may need to do preservation photocopying for documents in old accession folders. Accession documents may include Thermofax™ and other fading records, brittle or torn documents, or documents on highly acidic paper. Refer to *COG 19/4, Archives: Preservation Through Photocopying*. Mark the copies as copies, and include the date and reason for copying. Don't discard the originals. Encapsulate originals if necessary to protect the document(s) and the other contents of the folder.

9. *Required documents in the Accession Folder*

You must keep the following documents in the accession folder.

- Accession Receiving Report, Form 10-95 Rev. (Figure 2.2)
- transfer of ownership or custody document appropriate to the accession type

Gift: Deed of Gift, Form 10-830 Rev. (Figure 2.3)
Last Will and Testament

Purchase: Receiving Report Copy of the Order for Supplies or Services
Form 10-3470 (2-97) or OF-347
Governmentwide Purchase Card (Credit Card) Receipt
DI-1 Requisition or Procurement Request and Invoice or Sales Slip
Copy of the Purchase Contract

Exchange: Exchange Agreement (Figure 2.8)

Transfer: Transfer of Property, Form DI-104 (Figure 2.9)

Field Collection: Receipt for Property, Form DI-105 (Figure 2.1)

Incoming Loan: Incoming Loan Agreement, Form 10-98 Rev. (Figure 2.11)

- legal documents (as applicable)
 - ownership statement
 - copyright statement
 - release forms
 - Noncash Charitable Contributions Form (IRS Form 8283)
 - permits (archival copies of scientific research and collecting permits or Archeological Resources Protection Act permits)
 - insurance documents for incoming loans

10. *Other Documents in the Accession Folder*

Other types of documentation to store in the accession folder include:

- correspondence

Include telephone notes, memoranda, copies of e-mail correspondence, and any other records of communication about the accession.

- miscellaneous documentation

- letter of acknowledgement
- Gift Acknowledgement Certificate (Figure 2.5)
- restrictions and sensitivities
- research notes
- evidence of historical authenticity, such as documents that authenticate age, identity, or historical association*
- notes and correspondence on specimen taxonomy, identification, and geological provenience*
- shipping documents
- appraisals and evaluations
- Object Condition Reports, Form 10-637
- object treatment requests and conservation treatment reports*

* In some instances, you may want to store this information in a catalog folder.

Include the name and address of the source and the date you receive the information. Include the name and title of the park staff who recorded the information. Refer to Chapter 3: Cataloging, in this handbook for information on catalog folders.

- photographs

Keep photographs that document an object's acquisition or condition in the accession folder. Store photos in archival sleeves with a cross-reference to the negatives, which you store separately. Provide a cross-reference to images that are too large to fit in the accession folder, such as aerial photographs.

11. *Outgoing Loan and Deaccession Documents in the Accession Folder*

You may store outgoing loan documentation in the accession folder or in an outgoing loan folder.

Refer to Section C of Chapter 5: Outgoing Loans, in this handbook for information on filing paperwork for loans that involve multiple accessions.

You may store deaccession documentation in the accession folder or in a deaccession folder.

Refer to Section D of Chapter 6: Deaccessioning, in this handbook for information on filing paperwork for deaccessions that involve multiple accessions.

12. *Accession File*

The accession file is a series of accession folders that you file numerically with the accession book in an insulated, locked file.

The accession file is a permanent file that never leaves the park. You must monitor and control access to this file and the information it contains.

The documents in the accession file support the government's claim to the title or custody of museum property. The park uses the accession file in the current, ongoing management of park resources. Accession documents are therefore exempt from Federal Records Management retirement procedures.

Refer to Chapter 1: Getting Started, in this handbook for information on insulated files.

13. *Source of Accession*

You have the option of maintaining a manual source of accession file. ANCS+ will print source of accession information that you can file alphabetically in a 5X8" box or file cabinet. The source of accession card contains:

- source of accession name
- source of accession address
- source of accession telephone
- accession numbers
- description of each accession

See Figure 2.19 for a sample source of accession card.

14. *Changing Accession Type*

Occasionally you may have to document changes in accession type. For example, an incoming loan may become a gift or a purchase.

When you are converting all the objects in an accession to another accession type:

- Retain the original accession number.
- Change the accession type in the accession book. Draw a line through the old entry in the How Acquired column. Enter the new accession type in the column. Include the date of the change and your initials.
- Change the accession type for the ANCS+ accession record. Note the change in type in the Other Comments field.
- Print a new Accession Receiving Report, Form 10-95 Rev. (Figure 2.2).
- File the transfer of ownership document, such as a deed of gift in the accession folder.

When you are converting part of the objects in an accession to another accession type:

- Give a new accession number to the objects that are part of the new accession type.
- Follow accession procedures to document the new accession.
- Cross-reference the two accessions in the accession book, ANCS+, and on the accession receiving reports.
- Update the incoming loan form and original accession records to show the removal of the objects.

Note: You will have to adjust your CMR to show the change.

W. List of Figures

- + Figure 2.1 Receipt for Property (Form DI-105)
- +* Figure 2.2a-b Accession Receiving Report (Form 10-95 Rev.)
- +* Figure 2.3 Deed of Gift (Form 10-830 Rev.)
- Figure 2.4 Letter of Acknowledgment (Sample)
- Figure 2.5 Gift Acknowledgement Certificate
- Figure 2.6 Ownership Statement (Sample)
- Figure 2.7 Transfer of Copyright Statement (Sample)
- + Figure 2.8a-b Exchange Agreement (Sample)
- +* Figure 2.9 Transfer of Property (Form DI-104)
- Figure 2.10 Instructions for Incoming Loan Agreement
- +* Figure 2.11a-b Incoming Loan Agreement (10-98 Rev.)
- +* Figure 2.12 Conditions for Incoming Loans (Form 10-98a Rev.)
- Figure 2.13 Flow Chart for Incoming Loans
- + Figure 2.14 List of Objects (Form 10-417)
- Figure 2.15 States with Old Loan Law Citations
- * Figure 2.16 Accession Book (Form 10-256) (Sample)
- Figure 2.17 Flow Chart for Accessioning
- + Figure 2.18 Accession Folder Cover Sheet (Form 10-255 Rev.)
- + Figure 2.19 Source of Accession Card (Sample)

- + Print these forms from ANCS+.

- * You must use the Accession Book (Form 10-256) and the Accession Receiving Report (Form 10-95 Rev.) for all accessions. You must use the Deed of Gift (Form 10-830 Rev.) for all donations. You must use the Transfer of Property (Form DI-104) for all transfers between federal entities. You must use the Incoming Loan Agreement (Form 10-98 Rev.) and Conditions for Incoming Loans (Form 10-98a Rev.) for all incoming loans.

DI-105
(Revised 5/88)

UNITED STATES
DEPARTMENT OF THE INTERIOR

BUREAU OR OFFICE

RECEIPT FOR PROPERTY

NUMBER		DESCRIPTION (INCLUDE SERIAL NUMBERS, MODEL, ETC)	QUANTITY	UNIT OF ISSUE	COST
ITEM	PROPERTY				
1					
2					
3					
4					
5					
6					
7					
8					
9					
11					
12					
13					
14					
15					
16					
17					
18					
19					
20					
Issued by: (Name and Title)			Date Issued:		
It is understood that I am personally responsible for the property listed hereon and that if any of the property is lost, stolen damaged or destroyed through my simple or ordinary neglect or negligence or gross negligence I can be held financially liable as determined by a Board of Survey.					
Received By: (Name and Title)			Signature and Date:		

RETURN ORIGINAL TO EMPLOYEE UPON TURN-IN OF PROPERTY

Figure 2.1. Receipt for Property (Form DI-105)

Accession Receiving Report

Park Name _____

Use this record to document the receipt of objects and collect pertinent information on an accession from the Source of Accession (donor, vendor, field collector, lender, etc). If additional space is needed, attach a separate sheet. Blank copies of this form should be kept on hand by all employees who are likely to receive museum objects on behalf of the National Park Service.

The following information pertains to objects listed on the attached form:

Nature of accession: _____

Name and address of Source of Accession: _____

Daytime Telephone Number: _____

Give a brief description, identification and history of the collection. Note locality collected or purchased, give site names and numbers if appropriate. This information is provided by the source of accession only.

Project name (if applicable): _____

Give overall condition on arrival. Specific object condition must be noted on attached form.

Remarks: _____

Objects/Specimens Received by: _____ Date: _____
Signature of Employee, Title

at: _____
(Park location)

I certify that the objects described above and on the attached document have been received and inspected.

(Signature of Designated Receiving Officer) Date: _____

Figure 2.2a. Accession Receiving Report (Form 10-95 Rev.)

National Park Service

Accession Number

Accession Receiving Report (Continued)

Park Name _____

Give a brief description, identification and history of the collection. Note locality collected or purchased, give site numbers if appropriate. This information is provided by the Source of Accession only. Include (or attach) a list of objects in the accession, noting specific object condition.

Figure 2.2b. Accession Receiving Report (Continued) (Form 10-95 Rev.)

UNITED STATES DEPARTMENT OF THE INTERIOR NATIONAL PARK SERVICE		FOR NPS USE ONLY _____ ACCESSION NUMBER _____
DEED OF GIFT		
NAME OF DONOR(S)		TELEPHONE NUMBER (Give Area Code)
ADDRESS (Number, Street, City, State and Zip)		
<p>Whereas the National Park Service is dedicated to the preservation and protection of objects significant to the interpretation of the National Parks throughout the United States,</p> <p>I/We do hereby unconditionally donate to the National Park Service, for its unrestricted use, the item(s) listed below.</p> <p>I/We also acknowledge actual delivery of the item(s) listed below to the National Park Service.</p> <p>I/We certify that I/we hold free and clear title to the subject property and that I/we may dispose of it in any manner that I/we may determine.</p> <p>I/We certify that I/we hold free and clear title to the copyright for the subject property and that I/we may dispose of it in any manner that I/we may determine.</p>		
DONOR(S) SIGNATURE (Please use ball point pen)		
SIGNATURE	DATE	
SIGNATURE	DATE	
<u>DESCRIPTION OF OBJECTS</u>	<u>CONDITION</u>	
The National Park Service hereby gratefully acknowledges the receipt of the item(s) listed above.		
SIGNATURE	DATE	
TITLE		
PARK		
ADDRESS		
GIFTS TO THE NATIONAL PARK SERVICE ARE TAX DEDUCTIBLE AS CHARITABLE CONTRIBUTIONS, HOWEVER IT IS THE DONOR'S RESPONSIBILITY TO SECURE APPRAISALS TO SUPPORT DEDUCTIONS. (See IRS Pamphlet 561)		
FORM 10-830 Rev. January 1998		

Figure 2.3. Deed of Gift (Form 10-830 Rev.)

**National Park Service
Letterhead**

File Code
Accession Number

June 10, 1999

Mr. George A. Monroe
912 West Main Street
Kingston, Missouri 63555

Dear Mr. Monroe:

The National Park Service is pleased to accept your very generous donation of your great grandfather's uniform and diary from the Battle of Smith's Creek. The uniform and diary arrived safely at the park on June 1, 1999. As you know from our discussions, these items will be a significant addition to (the park's) museum collection and to the work of preserving and interpreting the park's unique and rich history. The detailed information you provided about these items will be included in the park's museum records.

To complete the transfer of ownership, please sign and date both copies of the enclosed Deed of Gift form. Retain one copy for your records, and return one copy to us. A stamped, pre-addressed envelope for returning the signed gift form is enclosed for your convenience.

Gifts to the National Park Service are tax deductible as charitable contributions, to the extent permitted by law.

We are most grateful for your gift and your interest in the National Park Service.

Sincerely,

Superintendent

Enclosures

Figure 2.4. Letter of Acknowledgment (Sample)



United States Department of the Interior
NATIONAL PARK SERVICE

*Your valued gift
of*

has been received and is gratefully acknowledged.

Respectfully yours,

_____ 20 _____

To _____

Figure 2.5. Gift Acknowledgment Certificate

U.S. Department of the Interior
NATIONAL PARK SERVICE

Ownership Statement

I/we, _____ (print name), do hereby represent, warrant, certify, and guarantee the following information to be true and correct:

1. I/we am the (*check one*)
____ owner
____ authorized agent for the owner
of the object described in the _____ (purchase document) dated _____.
2. [*For authorized agents only*] I am fully authorized by the owner of the object to enter into this transaction and to execute the warranties and representations herein.
3. The object is authentic and of the period indicated on the _____ (purchase document).
4. I acquired the object from _____

5. If origin is not USA, the object was legally exported from its country of origin. The object has been legally exported from and imported into all countries through which it has passed.
6. No customs, tax, patrimony or other laws or regulations applicable to the object, its sale, export, or import have been broken.
7. There are no liens or other encumbrances of any kind whatsoever against the object or title to them.
8. I/we certify that I/we hold free and clear title to the object and I/we may dispose of it in any manner that I/we may determine.

Signature: _____ Date: _____

Signature: _____ Date: _____

Address: _____

Figure 2.6. Ownership Statement (Sample)

U.S. Department of the Interior
NATIONAL PARK SERVICE

Transfer of Copyright Statement

I/we, _____ (print name), do hereby represent, warrant, certify, and guarantee the following information to be true and correct.

I/we certify that I/we hold free and clear right, title, and interest in the copyright in the material described in the _____ (name of document) dated _____ and that I/we may dispose of it in any manner that I/we may determine.

I/we transfer the copyright for the material to the National Park Service.

Signature: _____ Date: _____

Signature: _____ Date: _____

Address: _____

Figure 2.7. Transfer of Copyright Statement (Sample)

Exchange Agreement

In accordance with the authority granted to the Secretary of the Interior by the Museum Act of 1955 (16 USC, Sect. 18 [f]), and in consideration of the mutual promises set forth in this Agreement, the National Park Service and _____ (other party) enter into this agreement for the exchange of museum objects.

1. _____ (NPS Unit) hereby becomes the owner of the objects listed on the first attached inventory (Attachment 1 of this Agreement). _____ (other party) hereby becomes the owner of the objects listed on the second attached inventory (Attachment 2 of this Agreement).
2. _____ (other party) represents and warrants that he/she/they will possess clear title, free of all liens, claims, and encumbrances of any kind, to the objects listed in Attachment 1 at the time the exchange takes place. If at the time the exchange is to occur _____ (other party) is unable to present the objects listed on Attachment 1 and proof of ownership for the said objects he/she/they is/are exchanging, the National Park Service is under no obligation to complete the exchange.
3. _____ (other party) represents and warrants that the objects listed on Attachment 1 were secured in compliance with all applicable International, Federal and State laws. Documentation evidencing the source of acquisition of the objects listed on Attachment 1 will be attached to this Agreement at the time the exchange takes place (Attachment 3).
4. _____ (other party) represents and warrants that the objects listed in Attachment 1 have been authenticated and appraised in writing, at market value, by at least one objective appraiser within six months previous to the date of this agreement. Copies of the appraisals for the NPS and non-NPS items are attached to this Agreement (Attachment 4).
5. _____ (other party) represents and warrants that he/she/they is/are the sole owner(s) of all rights in the objects listed on Attachment 1. _____ (other party) hereby assigns in _____ (NPS unit) all of _____ (other party) common law and statutory copyrights to the objects listed in Attachment 1. _____ (other party) agrees to indemnify _____ (NPS unit) against any claims, damages, losses, or expenses of any kind that _____ (NPS unit) may suffer as a result of any infringement or alleged infringement of the copyrights to _____ (NPS unit).
6. Title to the objects exchanged under this agreement shall pass when the objects have been delivered pursuant to the terms of this Agreement and the parties have inspected the objects and found them to be in a satisfactory condition and are as represented in this Agreement. Inspections of the objects shall occur on the date of delivery.
7. As provided by 41 U.S.C. §§ 22, no member of or delegate to Congress, or Resident Commissioner shall be admitted to any share or part of this Agreement or to any benefit that might arise therefrom; but this provision shall not be construed to extend to this Agreement if made with a corporation for its general benefit.
8. No NPS employee or members of a NPS employee's immediate family shall be admitted to any share or part of this Agreement or to any benefits that may arise therefrom.
9. The exchange of all firearms must be in compliance with all state and local law enforcement regulations related to the acquisition of firearms. Upon consummation of this Agreement, the National Park Service shall not be liable for any action related to the use of firearms described within the Agreement.
10. The National Park Service will pay all costs of transporting and insuring the objects listed on Attachment 2 to _____ (address).

Figure 2.8a. Exchange Agreement (Sample)

Exchange Agreement (Continued)

11. The parties agree that the physical transfer of all objects covered by this Agreement will occur on or before _____ (date) and that time is of the essence to this Agreement. If _____ (other party) fails to deliver the objects listed on Attachment 1 to the agreed-upon place of delivery by the date given in this paragraph, the National Park Service may, at its option, terminate this Agreement, recover any objects which it may have delivered pursuant to this Agreement and sue for damages for undue delay of the performance of this Agreement or for specific performance of this Agreement. _____ (NPS unit) remedies hereunder are not exclusive and _____ (NPS unit) retains the right to pursue any and all legal remedies available to it for the breach of this Agreement.
12. Catalog information on all NPS objects incorporated under this Agreement is included by reference to the NPS catalog number listed on Attachment 2.

For the NATIONAL PARK SERVICE (Receiving):

Recommended: _____
(Park Curator) (Date)

Approved: _____
(Superintendent) (Date)

For the other PARTY

Name: _____

Approved: _____
(Date)

Approved: _____
(Date)

Address: _____

Telephone: _____ FAX: _____

Figure 2.8b. Exchange Agreement (Continued) (Sample)

DI-104
(Rev. 6/88)

UNITED STATES DEPARTMENT OF THE INTERIOR TRANSFER OF PROPERTY		Page ____ of ____		
		Report No.		
		Date		
Transfer From: (Organization and Complete Address)		Transfer To: (Organization and Complete Address)		
Appropriation and Accounting Data:				
ITEM NO.	QUANTITY OR PROPERTY ID NO.	ITEM DESCRIPTION <i>(Include model & serial number)</i>	ORIGINAL ACQUISITION COST (OAC)	CONDITION CODE

SHIPPING AND RECEIVING INFORMATION			
Date Shipped:		Date Received:	
Authorized Signature:		Authorized Signature:	
Official Title:		Official Title:	
Adjustment to property records (Property Official Signature):	Date Completed	Financial Official Signature (if Required):	Date Completed

U.S. Government Printing Office 1988 673-017/96039

Figure 2.9. Transfer of Property (DI-104)

INSTRUCTIONS FOR INCOMING LOAN AGREEMENT

Accession Number	Enter the accession number for the loan. Example: PARK-55
Borrower	Enter the name of the park.
Borrower Address	Enter the park's street/box, city, state, zip code, telephone number, and FAX number.
Superintendent	Enter the name of the superintendent or center chief, for authorization and contact purposes.
Borrower Shipping Address	Enter the shipping address of the park, if it is different from the mailing address.
Lender	Enter the name of the lender (for example, University of Arizona). Indicate whether the lender is a NPS unit or non-NPS.
Lender (Department)	Enter the department or division of the lending institution (for example, Department of Anthropology), where applicable.
Lender Address	Enter the street/box, city, state, zip code, country (if outside USA), telephone number and FAX number.
Responsible Official (Lending Institution)	Enter the name and title of the responsible individual (or agent) of the lending institution (for example, G. A. Lindsay, Director), if applicable.
Lender Shipping Address	Enter the shipping address of the lender, if it is different from the mailing address.
Purpose of Loan	Indicate the purpose of the loan (exhibit, study, collections management, storage, or other). If other, explain.
Credit Line	Record the credit line as it is to appear in exhibit graphics, publications, or other media.
Objects in Loan	List the objects in the loan. Include the object name, item count or quantification, description, condition, and insurance value (if appropriate). For loans involving several objects, attach an inventory or a computer-generated list.
Initiation Date	Record the date on which the agreement is to go into effect.
Termination Date	Enter the termination date of the loan. Loans to repositories cannot exceed ten years. All other loans cannot exceed three years.
Insurance	Indicate whether the insurance will be waived or carried by the lender or borrower. Enter the name of the insurance company and the policy number. Refer to Chapter 4 of this handbook for information on insurance.
Packing and Shipping	Indicate who will be responsible for packing the objects. Provide information on the method of shipping for sending and returning the loan. If a shipping company is used, include the name, address, and phone number. Indicate who will be responsible for shipping charges.
Loan Conditions	Indicate whether a facilities report is required. Include any other additional conditions. Attach a copy of the Conditions for Incoming Loans (Form 10-98a Rev.).
Signature and Date Lines	Enter the name of the superintendent and the lender. Both parties must sign and date the agreement. The repository chief or institution director must sign the agreement for repository loans.
Return Status (Partial or Complete)	Indicate whether the entire loan has been returned. If part of the loan has been returned, enter date of return for each object returned.
Extension Information	For extended loans, enter the new termination date.
Return Signature	Enter the name of the lender. The lender must sign and date the agreement when the entire loan is returned.
Sending and Returning the Loan Agreement	The superintendent signs two copies of the loan agreement and sends them to the lender. The lender signs and returns one copy to the park and keeps the other signed copy. On return of the entire loan, the lender signs and dates the agreement and sends a copy to the borrower.

Figure 2.10. Instructions for Completing and Sending the Incoming Loan Agreement

US Department of the Interior
National Park Service

Incoming Loan Agreement

Accession No.

NPS Unit (Borrower):

(Street/Box)

Telephone:

(City/State/Zip)

Fax Number:

Superintendent (please print):

Shipping Address (if different):

LENDER:

(Department)

Telephone:

(Street/Box)

Fax Number:

(City, State, Zip, Country)

Title:

Responsible Official (Lender):

Shipping Address (if different):

NPS Status:

PURPOSE OF LOAN:

Credit Line:

OBJECTS IN LOAN:

INITIATION DATE

TERMINATION DATE:

INSURANCE AND SHIPPING/PACKING:

Insurance Paid By:

Insurance Company:

Policy No.:

Packer:

Shipping Paid By:

Method of Shipping: Outgoing:

Return:

Form 10-98 Rev.
February 1998

Figure 2.11a. Incoming Loan Agreement (Form 10-98 Rev.)

US Department of the Interior
National Park Service

Accession No.

Incoming Loan Agreement (Continued)

LOAN CONDITIONS:

Incoming loans are subject to the terms and conditions noted on the attached Conditions for Incoming Loans.

Additional Loan Conditions:

SIGNATURES:

ON INITIATION OF THIS AGREEMENT: The undersigned borrower is an authorized agent of the National Park Service. Signature indicates agreement to terms specified in this loan agreement and attached conditions.

PLEASE SIGN BOTH COPIES AND RETURN THE ORIGINAL TO THE NPS.

Name of Responsible Official (Lender or Authorized Agent), Title (Please print)

Signature

Date

Name of Superintendent (Borrowing NPS Unit), (Please print)

Signature

Date

RETURN STATUS:

Extension Termination Date:

RETURN OF LOAN:

The undersigned is an authorized agent of the lender. Signature acknowledges receipt of all material in good condition or in condition as noted on this agreement or in attached object condition report(s). A signed copy is sent to the borrower to acknowledge the return of the loan.

Name of Lender or Authorized Agent (Please print)

Signature

Date

Form 10-98 Rev.
February 1998

Figure 2.11b. Incoming Loan Agreement (Continued) (Form 10-98 Rev.)

Conditions For Incoming Loans

Care and Preservation

1. The NPS will give to objects borrowed the same care as it does comparable property of its own. It is understood by Lender and Borrower that all tangible objects are subject to gradual inherent deterioration for which neither party is responsible.
2. Evidence of damage at the time of receipt or while in NPS custody will be reported as soon as practicable, to the Lender.
3. No alteration, restoration, or repair will be undertaken without the written authorization of the Lender.
4. The Lender certifies that the objects lent are in such condition as to withstand ordinary strains of packing and transportation.

Transportation and Packing

1. Costs of packing and transportation will be borne by the borrowing park unless the loan is at the Lender's request. The method of shipment must be agreed upon by both parties.
2. Customs regulations will be adhered to in international shipments.
3. The Lender will assure that said objects are adequately and securely packed for the type of shipment agreed upon, including any special instructions for unpacking and repacking. Objects will be returned packed in the same or similar manner as received unless authorized by the Lender.

Insurance

1. Unless objects are covered by a specific insurance policy, NPS liability for loss or damages will be subject to recovery under the Federal Tort Claims Act (28 U.S.C. 2671-2630, as amended), if loss or damage occurs while in the custody of the NPS and the loss can be proved to be caused by negligence or wrongful act of the Federal Government.
2. On request of Lender objects will be insured by the NPS under an all risk wall-to-wall museum collections policy subject to the standard exclusions for the duration of the incoming loan agreement. Insurance will be placed in the amount specified by the Lender herein, which must reflect fair market value at the time of the loan. If the Lender

fails to indicate an amount, the NPS will set a value for purposes of insurance for the period of the loan.

3. If the Lender elects to maintain his own insurance coverage, the NPS must be supplied with a certificate of insurance naming the NPS and the United States Government as additional insureds or a waiver of subrogation. The NPS shall not be responsible for any error or deficiency in information furnished to the Lender's insurer or for any lapse in coverage.
4. The Lender is responsible for updating insurance valuations.
5. The amount payable by an insurance policy is the sole recovery available to the Lender in event of loss or damage.

Photography

Unless otherwise notified in writing, the objects lent may be photographed by the NPS for record, educational, catalog, and publicity purposes. It is understood that objects on exhibit may be photographed by the general public.

Ownership and Address Change

By signing the Agreement the Lender certifies that he is the legal owner of the described property. It is incumbent upon the Lender to notify the NPS in writing of any change of address. In case of change in legal ownership during the period of the loan, the new owner is required to establish his legal right by proof satisfactory to the NPS.

Return of Loans

The loan agreement may be terminated by either party given reasonable notice in writing. All notices to the Lender in regard to termination of the loan are considered sufficient if sent by registered mail to the Lender at the address given in this record. Unless otherwise notified in writing, the NPS will release the objects only to the Lender. If NPS efforts to contact the Lender, within a reasonable period following the expiration of the loan, are unsuccessful, and no special arrangements have been made for the return of the loan, then the objects will be placed in storage at the Lender's risk and expense. If after 3 years the property is not withdrawn, it may be deemed to become the unrestricted property of the Federal Government for administration by the NPS.

Figure 2.12. Conditions for Incoming Loans (Form 10-98a Rev.)

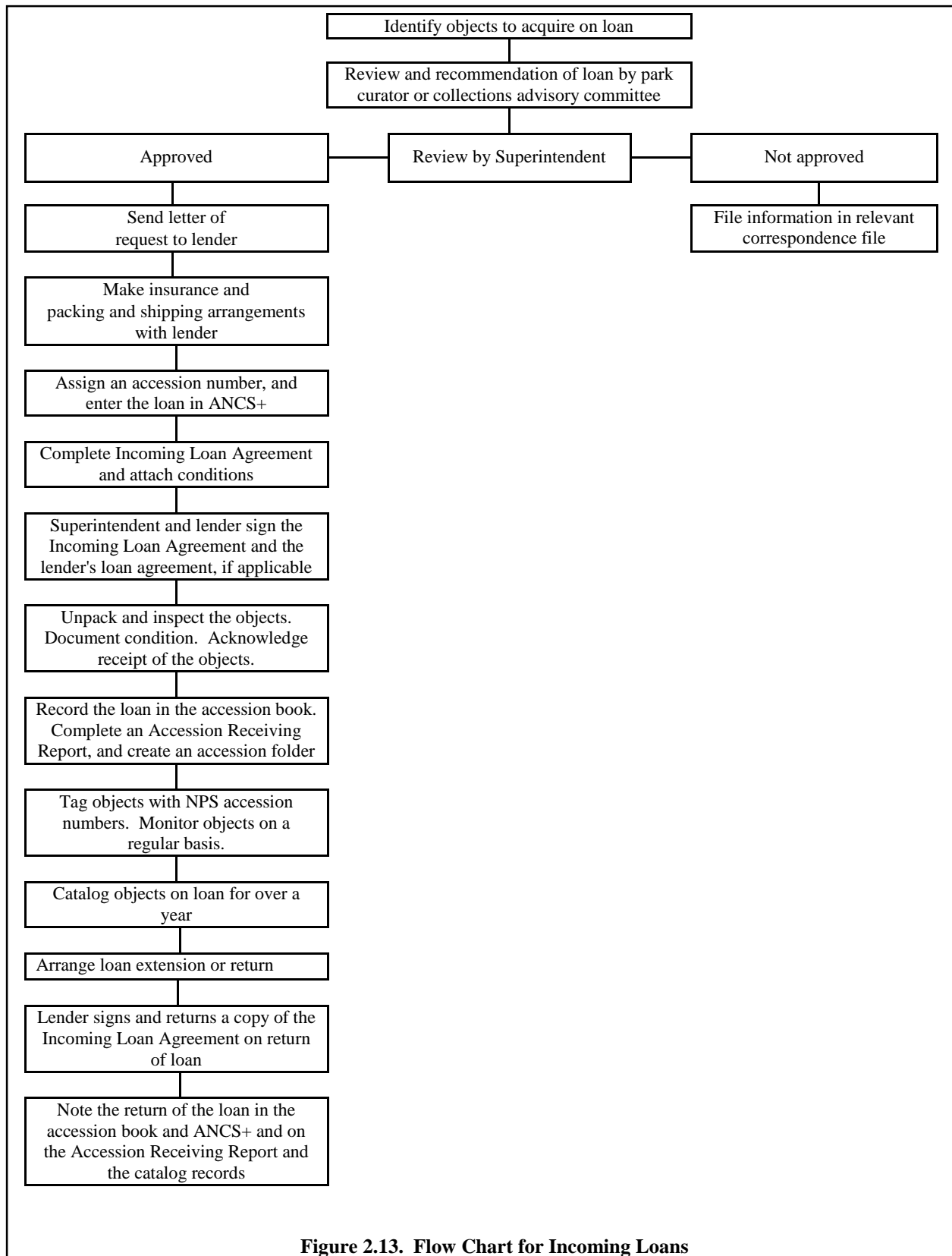

Figure 2.13. Flow Chart for Incoming Loans

US Department of the Interior
National Park Service

Page _____ of _____

LIST OF OBJECTS

Park Acronym _____

Number _____

CATALOG NUMBER	ACCESSION NUMBER	ITEM COUNT OR QUANTITY	OBJECT NAME	DESCRIPTION AND CONDITION	VALUE	COMMENT

NPS Form 10-417
July 1995

Figure 2.14. List of Objects (Form 10-417)

State Old Loan Law Citations

Note: This list may be incomplete. Several additional states are considering passing old loan legislation. If this doesn't include your state, consult your state laws for recent legislation on old loans.

Alabama St. § 41-6-72 (applies only to the state Department of Archives and History)
Arizona Rev. Stat. Ann. § 44-351 *et seq.*
California Civ. Code § 1899
Colorado Rev. Stat. § 38-13-101 *et seq.*
Florida Stat. Ann. § 265.565 *et seq.*
Indiana Code Ann. § 32-9-10-1 *et seq.*
Iowa Code Ann. § 305B
Kansas Stat. Ann. § 58-4001 *et seq.*
Kentucky Rev. Stat. Ann. § 171.830 *et seq.*
Louisiana Rev. Stat. Ann. § 25:345 (applies only to state museums)
Maine Rev. Stat. Ann., tit. 27, § 601 *et seq.*
Michigan Comp. Laws Ann. § 399.611 *et seq.*
Mississippi Code Ann. § 39-19-1 *et seq.*
Missouri Stat. Ann. § 184.102 *et seq.*
Montana Code Ann. § 22-3-501 *et seq.*
Nevada Rev. Stat. Ann. § 381.009 (applies to specified museums and historical societies)
New Hampshire Rev. Stat. Ann. § 201:E-1 *et seq.*
New Mexico Stat. Ann. § 18-10-1 *et seq.*
North Carolina Gen. Stat. § 121-7(c)
North Dakota Cent. Code § 47-07-14 (applies only to state museums)
Oregon Rev. Stat. § 358.415 *et seq.*
South Carolina Code Ann. § 27-45-10 *et seq.*
South Dakota Cod. Laws § 43-41C-1 *et seq.*
Tennessee Code Ann. § 66-29-201 *et seq.*
Texas Property Code Ann. § 80.001 *et seq.*
Washington Rev. Code Ann. § 63.26.010 *et seq.*
Wisconsin Stat. Ann. § 171.30 *et seq.*
Wyoming Stat. § 34.-23-101 *et. seq.*

Figure 2.15. State Old Loan Law Citations

ACCESSION BOOK

Accession Number	Date Received	Description	Received From	How Acquired	Remarks	Catalogue Number
1	Nov 9, 1998	one oil painting "Storm At Sea" by Thomas Moran	Jones, John St. 215 Main St. Staunton VA 28401	Gift		PARK 1
2	April 4, 1999	103 boxes of excavated material & field records from the Hill Site OBI 0012	National Park Service Bell, Martha, Principal Investigator	Field Collection	Project 116	
3	May 20, 1999	medical kit and Dr. Thomas Knoll's diary	Weathercure Antiques 49 Hill St. Olney, MD 23421 301-726-4253	Purchase		PARK 403 PARK 404
4	June 1, 1999	125 botanical specimens PARK-1999-008	National Park Service Ortega, Victor, Biologist	Field Collection	Collection # 76-340	
5	June 13, 1999	Confederate enlisted man's greatcoat	Battle Museum Battle Boulevard Burling TX 75219 114-543-2345	loan	Returned Feb 5, 2000	
6	Aug 21, 1999	personal correspondence and photographs of the Burns family	Fish and Wildlife Service P.O. Box 3247 Arlington VA 22203 703-358-1944 Attn: James Weber	Transfer		PARK 673

Figure 2.16. Accession Book (Form 10-256) (Sample)

Refer to Figure 2.13 for a Flow chart on incoming loans.

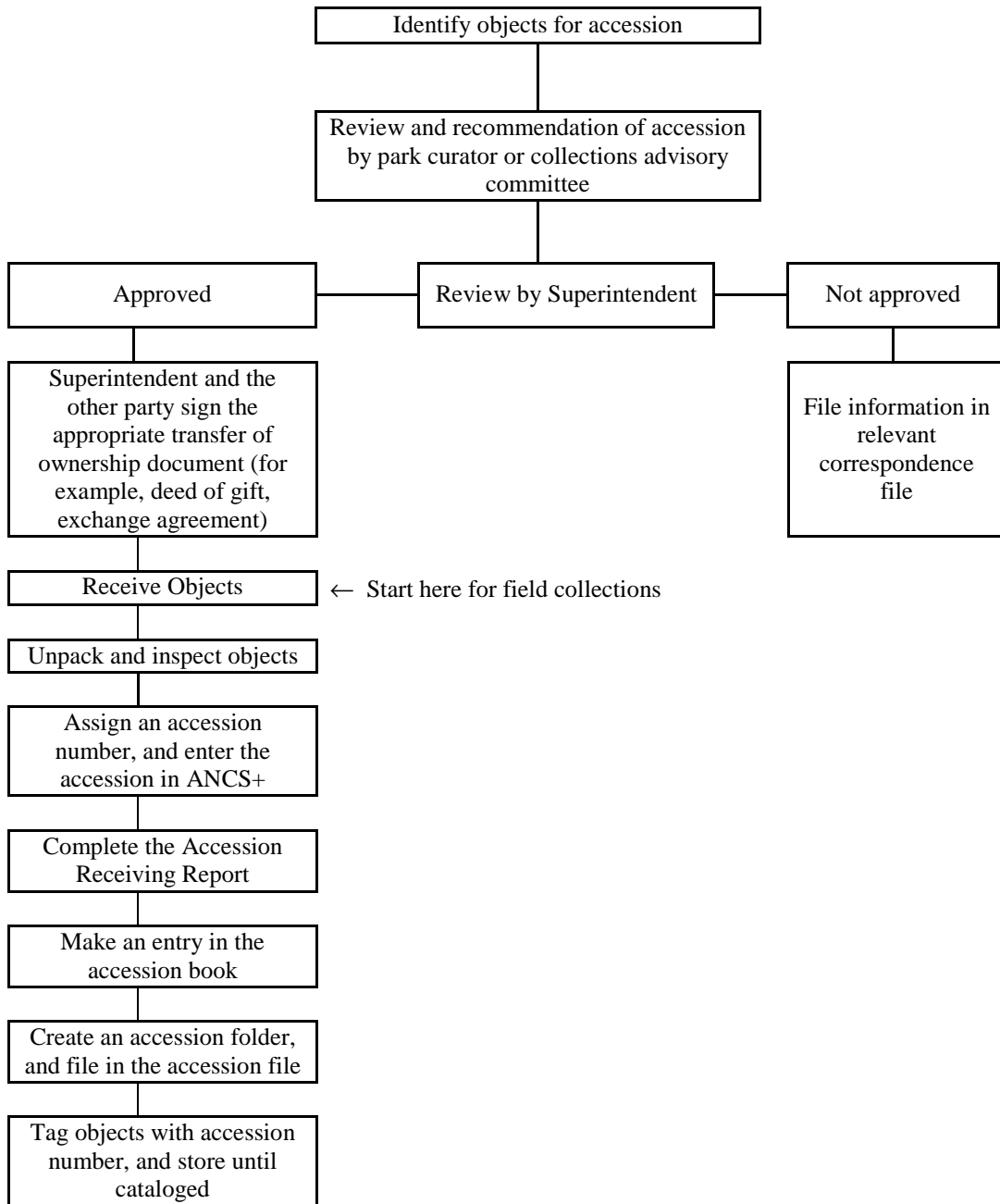

Figure 2.17. Flow Chart for Accessioning

Accession Number _____ Park Name _____

ACCESSION FOLDER COVER SHEET

INSTRUCTIONS: Use this Accession Folder cover sheet when the National Park Service acquires museum collections. Include all documents relating to the accession. Complete box "A" for permanent accessions (gifts, purchases, exchanges, transfers, and field collections). Complete box "B" for temporary accessions (loans). The Accession Receiving Report (Form 10-95) is required for all accessions. Insert this cover sheet in the accession folder.

<p>A. PERMANENT ACCESSIONS</p> <ul style="list-style-type: none"> <input type="checkbox"/> Accession Receiving Report (Form 10-95) <input type="checkbox"/> Accession Receiving Report: Continuation sheet (Form 10-95c) <input type="checkbox"/> Gift <ul style="list-style-type: none"> <input type="checkbox"/> Deed of Gift (Form 10-830) <input type="checkbox"/> Donor Letter <input type="checkbox"/> Last Will and Testament <input type="checkbox"/> Purchase <ul style="list-style-type: none"> <input type="checkbox"/> Receiving Report Copy of Purchase Order (Form 10-3470 or OF-347) <input type="checkbox"/> Requisition (DI-1) and Invoice or Sales Slip <input type="checkbox"/> Governmentwide Purchase Card (credit card) Receipt <input type="checkbox"/> Exchange Agreement <input type="checkbox"/> Transfer <ul style="list-style-type: none"> <input type="checkbox"/> Receipt for Property (DI-104) <input type="checkbox"/> Field Collection <input type="checkbox"/> Receipt for Property (DI-105) 	<p>B. TEMPORARY ACCESSIONS (LOAN)</p> <ul style="list-style-type: none"> <input type="checkbox"/> Accession Receiving Report (Form 10-95) <input type="checkbox"/> Accession Receiving Report: Continuation Sheet (Form 10-95c) <input type="checkbox"/> Incoming Loan Agreement (Form 10-98) <input type="checkbox"/> Receipt for Property (DI-105) <input type="checkbox"/> Other (Specify) _____ <p>Return Date: _____</p>
---	---

INDICATE LOCATION OF THE FOLLOWING:

	Accession Folder	Catalog Folder
1. Correspondence relating to transaction.....		
2. Insurance documents for loans to NPS.....		
3. Deaccessioning Information:		
a) Deaccession Form (Form 10-643).....		
b) Disposition Document.....		
c) Other.....		
4. Field Notes.....		
5. Research Notes.....		
6. Outgoing Loan Documentation:		
a) Outgoing Loan Agreement (Form 10-127).....		
b) Other.....		
7. Shipping documents.....		
8. Conservation records.....		
9. Appraisals.....		
10. Photographs.....		
11. Other (Specify).....		

NPS Form 10-255 Rev.
July 1999

Figure 2.18. Accession Folder Cover Sheet (Form 10-255)

Source of Accession Name: SCRIVEN, C.E.
Source of Accession Address:
213 SECOND AVENUE

Telephone:
(717)765-3425

YORK PA 17403-

Accession
Numbers

Description

PARK-00067

32 MID-19TH CENTURY BOOKS

PARK-00010

DIARY OF FRANKLIN CARTER
PHOTOGRAPHS OF THE CARTER FAMILY

Figure 2.19. Source of Accession Card (Sample)

Chapter 3: Cataloging

	<u>Page</u>
A. Overview	3:1
What is cataloging?	3:1
What is the purpose for cataloging?	3:1
Who uses catalog data?	3:1
Who must follow this chapter?	3:2
B. General Information on Cataloging	3:2
What are catalog records?	3:2
What is a catalog number?	3:2
When do I catalog objects?	3:3
How do I plan to reduce or eliminate my cataloging backlog?	3:3
How can I prevent a future catalog backlog from occurring?	3:3
Where do I get the information for cataloging?	3:3
How much time should I spend researching information for the catalog record?	3:4
How do I prepare to catalog a collection?	3:4
Should I develop site-specific cataloging guidelines?	3:4
What is the National Catalog of Museum Objects?	3:5
Do I need to restrict access to catalog data?	3:5
How do I provide access to the park's catalog data?	3:6
C. Cataloging Procedures	3:6
Should I use a worksheet when cataloging collections?	3:6
What is a catalog folder?	3:6
How do I complete a catalog record?	3:7
How can I gain preliminary control for new accessions?	3:7
What if I have unverified data?	3:8
What if I need to add or change information on the catalog record?	3:8
Can I catalog objects that are alike on the same catalog record?	3:8
How do I catalog objects with detachable parts?	3:8
Should I photograph objects while I'm cataloging?	3:8
Are there times when I don't need to photograph collections?	3:9
When do I mark an object with a catalog number?	3:9
What do I do with catalog data that I receive from centers, contractors, and other sources outside the park?	3:10
What is the relationship between the NPSpecies database and my catalog records?	3:10
D. Tracking Catalog Numbers	3:10
Can I release catalog numbers in advance?	3:10
When should I release catalog numbers outside the park?	3:10
How should I track the catalog numbers I release?	3:11
How can I find the last catalog number I used?	3:11
May I reuse catalog numbers?	3:11
What if I have missing catalog numbers?	3:12
What if I have duplicate catalog numbers?	3:12
How should I cross-reference catalog numbers with the accession records?	3:12
E. Cultural Resources (CR) Catalog Data Fields	3:12
Where do I find the data fields for CR catalog records?	3:12
What are the data fields for CR catalog records?	3:12
What are the discipline-specific fields for archeology records?	3:14
What are the discipline-specific fields for ethnology records?	3:14
What are the discipline-specific fields for history records?	3:14

What are the discipline-specific fields for archival/manuscript records in the Collections Management Module?	3:15
What is the Archives Module in ANCS+?.....	3:15
Must I catalog archival/manuscript collections in the ANCS+ Archives Module?.....	3:15
Where can I find information about the CR discipline classifications?	3:16
F. Natural History (NH) Catalog Data Fields	3:16
Where do I find the data fields for NH catalog records?.....	3:16
What are the data fields for NH catalog records?	3:16
What are the discipline-specific fields for biology records?	3:17
What are the discipline-specific fields for geology records?	3:17
What are the discipline-specific fields for paleontology records?	3:18
Where can I find information about the NH classifications and cataloging?	3:18
G. Making Changes on the Catalog Record	3:18
How do I make and track changes to a catalog record?	3:18
How do I change manual records that are not in ANCS+?	3:19
What is recataloging?	3:19
Do I submit the records I changed to the National Catalog?	3:20
Does the National Catalog print archival copies of recataloged records?.....	3:20
Does the National Catalog print archival copies of records with minor modifications?.....	3:20
Can I make changes to the NPS classification systems?.....	3:20
Can I make changes to the object name lists?	3:20
H. Submitting Catalog Records to the National Catalog.....	3:20
Must I submit catalog records to the National Catalog?	3:20
Why must I submit my catalog records to the National Catalog?.....	3:21
When do I submit my database to the National Catalog?	3:21
What do I submit to the National Catalog?.....	3:21
How do I prepare the data for submission?	3:22
How do I prepare the receipt for property?.....	3:22
Where do I send my submission?	3:22
What happens to my records at the National Catalog?	3:23
What should I do with the blue copies of my catalog records?.....	3:23
Does the National Catalog print white cardstock classification copies of catalog records?.....	3:23
I. List of Figures	3:24

BASIC REQUIREMENTS FOR NPS CATALOGING

Catalog all objects, specimens, and archival and manuscript collections that are part of the park's museum collection.

Accession objects before you catalog them. Refer to Chapter 2: Accessioning. Catalog museum collections as soon as you are able.

Make sure that contracts and permits that produce museum collections include the requirement to catalog the collections.

Classify museum collections by discipline: archeology, ethnology, history (including archival and manuscript collections), biology, geology, or paleontology. Refer to the appropriate appendix in the handbook for information on each discipline.

Enter all catalog records into ANCS+. Paper catalog records are optional.

To complete a catalog record, follow the:

- guidelines in this chapter and Appendix C of this handbook
- instructions in Chapter 2: Cataloging, in the *ANCS+ User Manual*
- on-line field help in ANCS+
- regional and/or park-specific cataloging guidelines, if applicable

Make sure the catalog record is accurate and understandable to someone looking for information about the object.

Use lot cataloging to catalog like objects in groups, rather than cataloging them individually. Refer to Appendix I in this handbook for guidelines on lot cataloging.

You must catalog all archival and manuscript materials at the collection level. Assign only one catalog number to the entire collection. Don't individually catalog the pieces of the collection. Further describe the collection at the series, file unit, and item level in the Archives Module, if recommended by the archival survey.

Assign a catalog number to each object or group of objects. Mark the catalog number on the object as part of the cataloging process. Refer to Appendix J in this handbook for marking techniques.

Keep track of the catalog numbers you use, including those you release in advance to NPS repositories and contractors.

If possible, photograph objects as part of the cataloging process. Refer to Appendix K in this handbook for basic instructions on record photography.

Make changes to the catalog record as needed to keep the data on the record accurate and current.

Submit a copy of your ANCS+ database to the National Catalog each year. Submit the database even if your park had no cataloging activity during the year. Include any new or recataloged records in a tag file within the database.

CHAPTER 3: CATALOGING

A. Overview

1. *What is cataloging?*

For National Park Service (NPS) museum collections, cataloging is the process of recording detailed information about individual items or groups of related items. Cataloging also includes assigning a unique identifying number to the item or group of items. You must have museum catalog records for all objects, specimens, and archival/manuscript collections in your park's museum collection. The information on the catalog records may be as important as the items themselves.

Note: You can catalog some objects and specimens in lots. Refer to Appendix I: Lot Cataloging, for guidelines on how to determine which items you can lot catalog.

You must catalog all archival and manuscript materials at the collection level. This means that you assign one catalog number to the entire collection. Don't individually catalog the pieces of the collection. You can further describe a collection at the series, file unit, and item level by using the ANCS+ Archives Module. Archivists generally describe very few collections at the item level. See Appendix D in this handbook for additional information about cataloging archives.

2. *What is the purpose for cataloging?*

Catalog records give you access to information about your museum collection for research and interpretation. They are also the primary property accountability records for museum objects. Catalog records tell you what objects you have, their condition, and where they're located. They provide physical and intellectual access to your museum collection.

3. *Who uses catalog data?*

Numerous people and institutions use data from your catalog records, including:

- NPS staff, (curatorial and interpretive staff, cultural and natural resource managers, archeologists, scientists, ethnographers, archivists, and the superintendent)
- exhibit planners
- conservators
- students
- researchers
- general public
- regional and Washington office staff
- educational, cultural, or scientific institutions (such as, museums, historical societies, and universities)

4. *Who must follow this chapter?*

The staff person or persons responsible for the museum collection must follow this chapter to catalog museum collections. You must catalog all objects that are part of the park's museum collection.

Note: You don't have to catalog short-term incoming loans that are at the park for less than a year. You must accession all incoming loans and track them using an incoming loan agreement. Refer to Chapter 2 in this handbook for information on incoming loans. Objects at a park for less than thirty days are in temporary custody and don't require a loan agreement. Refer to Section B.10 in Chapter 2 of this handbook.

See Section A.6 of Chapter 1 in this handbook for information on staffing requirements for museum collections.

B. General Information on Cataloging

1. *What are catalog records?*

Catalog records are both paper and electronic records. The NPS uses Form 10-254 to print catalog records. The form has two formats:

- Museum Catalog Record – CR, Form 10-254 Rev. (Figure 3.1) for cultural resources records for archeology, ethnology, history, and archival/manuscript collections.
- Museum Catalog Record – NH, Form 10-254B Rev. (Figure 3.2) for natural history records for biology, geology, and paleontology.

The electronic catalog record is part of the cultural resources and natural history databases in ANCS+.

Note: The electronic catalog record has more fields than the paper record. The Form 10-254 contains basic catalog data. The electronic catalog record includes separate screens for discipline-specific and park-specific data. You can print all the data in the record using the All Fields report in ANCS+. This report is not the official catalog record.

You must enter all catalog records into ANCS+, the NPS collections management software program. The use of paper records at the park is optional. The National Catalog prints and archives paper copies of all catalog records.

2. *What is a catalog number?*

A catalog number is the unique identification number for a particular item or group of items. You mark the catalog number on the object, and create a catalog record for each number. The number links the object and the documentation. Refer to Section C.11 in this chapter for information on marking the catalog number on the object.

Note: The catalog number identifies the object or group of objects. The accession number identifies the transaction that established NPS ownership of the object or group of objects.

3. *When do I catalog objects?*

If possible, catalog objects when you accession them.

Parks frequently have backlogs of cataloging to complete. Make a plan for reducing or eliminating the backlog, since it's hard to access and account for uncataloged collections. You must report the number of objects that you cataloged and the number of objects in the backlog each year on the Collections Management Report (CMR). Refer to Section VIII in Chapter 4 of this handbook for information on the CMR.

4. *How do I plan to reduce or eliminate my cataloging backlog?*

Planning for cataloging projects is part of the normal planning, programming, and budgeting process for any park. Be sure to include projects for cataloging the museum collection in the park's Resource Management Plan and Project Management Information System (PMIS). You will have to estimate the size and cost of the project and the time it will take to complete. You will also have to justify why the work needs to be done.

Note: Your current Collections Management Report (CMR) will have the number of items, by discipline, in the backlog. You may need to make adjustments to your CMR figures if you find additional items that you need to catalog.

To get an idea of the size of the job, locate all the materials that you need to catalog. Make sure that you have accessioned all items. Remember to include:

- archival collections that may be in offices or storage spaces
- large, mobile items that might be outside, such as farm machinery
- representative pieces of historic building fabric or architectural material

Give an estimate of the number of items in each discipline (such as biology or archives) that you need to catalog. The cost of cataloging varies by discipline.

Refer to Appendix B in this handbook for information on estimating cataloging costs.

5. *How can I prevent a future catalog backlog from occurring?*

It's important to keep your backlog from growing larger in the future. This may not be possible if you receive a large accession of materials. However, you can address the backlog of project-generated collections. Make sure all contract agreements and permits include the requirement to catalog all collections that the project generates.

6. *Where do I get the information for cataloging?*

Cataloging museum objects involves gathering and recording information from:

- physical observation
- accession records
- associated documentation

- research
- subject-matter specialists

Note: Refer to Appendix L: Bibliography, in this handbook for books that may be helpful in cataloging various types of objects and materials.

7. *How much time should I spend researching information for the catalog record?*

The amount of time you spend researching information about an object depends on:

- the importance of the object to your collection
- the availability of information
- your work schedule
- your research skills

Note: You can always add additional information to a catalog record at a later date.

Refer to Appendix B in this handbook for information on the costs of cataloging various types of collections.

8. *How do I prepare to catalog a collection?*

Before beginning to catalog, get a basic understanding of the entire collection and its purpose. Start by surveying the collection, including items on exhibit, on loan, and in storage. Look at the park's enabling legislation and Scope of Collection Statement (SOCS). What are the interpretive themes at the park? What's in the park library?

Become familiar with the park's accession book and records. Look at the cataloging that has been done and any research requests. Identify the material that you still need to catalog.

Knowledge of the collection as a whole allows you to:

- record information that is pertinent to the collection
- efficiently organize the cataloging process by sorting objects by type or material and conducting research on similar objects
- place objects in context within the whole collection
- provide cross-references to related objects

9. *Should I develop site-specific cataloging guidelines?*

Yes. Create written, site-specific cataloging guidelines. These guidelines set up the format for the catalog data at your park. They also help you maintain consistent data. Consistency is especially important if you have numerous catalogers and changes in cataloging staff. The person responsible for the collection should create the guidelines.

Site-specific guidelines might include:

- uniform location descriptions for areas in the park

- lists of eminent figures and organizations that are relevant to the park
- standard descriptions for various types of materials

Some regions provide regional guidelines for cataloging certain types of materials, such as archeology.

Note: Site-specific cataloging guidelines may supplement, but not replace, the NPS cataloging procedures in this handbook and the *ANCS+ User Manual*.

Appendix C in this handbook has information on uniform ways to describe and measure objects.

10. *What is the National Catalog of Museum Objects?*

The National Catalog of Museum Objects is one of the required NPS inventories and databases. It includes all catalog records for cultural objects, archival and manuscript materials, and natural history specimens in NPS museum collections. The National Catalog office is part of the Museum Management Program, National Center for Cultural Resources. The office is in Harpers Ferry, West Virginia. It serves as an off-site repository for your park's paper catalog records and electronic catalog record databases.

The National Catalog helps provide accountability, security, and preservation for electronic and paper catalog records and access to catalog data. The data would otherwise only be located at parks. The National Catalog protects park data during emergencies, disasters, or computer crashes.

Refer to Section H of this chapter for information on submitting catalog records to the National Catalog.

11. *Do I need to restrict access to catalog data?*

You should make most catalog data available to the public. However, you must restrict access to some types of location data. You are required by law to restrict access on the location data for:

- archeological excavations, including shipwrecks – Archaeological Resources Protection Act (ARPA) of 1979 (16 USC 470)
- cave and cave resources – Federal Cave Resources Protection Act of 1988 (16 USC 4301-4309)
- historic resources at risk of harm, theft, or destruction –National Historic Preservation Act of 1966, as amended (16 USC 470-470t, 110)

You should also place restrictions on the following location data. However, these data may be subject to Freedom of Information Act (FOIA) requests.

- Indian sacred sites –Executive Order 13007 – Indian Sacred Sites (May 24, 1996)
- nesting sites or specific habitat on threatened and endangered species – Endangered Species Act of 1973, as amended (16 USC 1531-1543)

You may withhold the following information from a FOIA request unless the Secretary approves release.

- information concerning the nature and specific location of mineral or paleontological specimens or objects of cultural patrimony within units of the NPS or resources that are endangered, threatened, rare, or commercially valuable – National Parks Omnibus Management Act of 1998 (16 USC 5937)

Use common sense when providing catalog data to the public. You should exclude current location and value data from general viewing.

12. *How do I provide access to the park's catalog data?*

ANCS+ has a public search function that allows researchers or non-museum staff to search the park's catalog data. You can choose which data fields on the catalog record are visible. Refer to Appendix C in the *ANCS+ User Manual* for information on using the public search function.

C. Cataloging Procedures

1. *Should I use a worksheet when cataloging collections?*

Use of a worksheet is optional. You can enter catalog data directly into ANCS+. Catalog worksheets for each discipline came with your *ANCS+ User Manual*. Contact the National Catalog office if you need additional copies.

2. *What is a catalog folder?*

A catalog folder is an archival folder that holds information that isn't contained on the catalog record. File the folder in numerical order by catalog number. Mark the catalog number on the folder using permanent ink. You can also write "Catalog Folder" on the tab.

Note: The ANCS+ catalog record includes a Catalog Folder field to tell you if you there is a catalog folder corresponding to the catalog record.

Proof of ownership and accession-related documentation always remain in the accession folder.

Typical contents of a catalog folder may include:

- research notes or reports on a specific object that is not part of a systematic collection

Note: Catalog the notes and reports from systematic collections as part of the associated records for the project. For example, a large archeological project may have a research report or chemical analysis for thousands of objects. In such cases, catalog the information as archives.

- conservation records, such as an object treatment request, condition report, treatment proposal, and conservation treatment report
- chemical analysis
- appraisals
- exhibition documentation

- publicity or other photographs (see Appendix K: Photography, for filing documentation photos) in protective enclosures
- material samples, such as upholstery, fabric, or paint
- publication citations

If possible, items in the catalog folder should be on acid-free paper. Store catalog folders in a separate drawer in the same, or similar, insulated and fireproof locking file as the accession file.

3. *How do I complete a catalog record?*

Refer to the appropriate section in Chapter 2: Cataloging, in the *ANCS+ User Manual*. The chapter contains a section for each discipline. ANCS+ also contains on-line field help for each field on the catalog record.

To save a record, you must enter data in all the mandatory fields. Refer to Sections E and F of this chapter for a list of the mandatory fields.

You will probably not have enough data on most objects to complete every non-mandatory field on the catalog record. Enter data in the fields for which you have information. The types of data that you record will vary between disciplines. Cite the sources of your data as needed.

Be accurate and thorough. Proof your work. Inaccurate or incomplete cataloging can result in unnecessary confusion in later years. Spelling errors make your work look unprofessional. Remember that other people, such as researchers, internet users, or park staff, may eventually see your work. Make sure the catalog record is clear and understandable to someone looking for information about the object.

Refer to Appendix C: Cataloging Guidelines, in this handbook for information on:

- how to record dimensions and weight in a consistent format
- the types of questions to ask when cataloging an object
- uniform techniques for description
- terms to use when describing condition

4. *How can I gain preliminary control for new accessions?*

You may not have time to do detailed cataloging when you accession an object. However, you can gain basic accountability for the object by completing the mandatory fields on the catalog record. Refer to Sections E and F of this chapter for a list of mandatory fields.

If you have a catalog record in ANCS+, the program will:

- do searches for the data
- get automated data from the record for the Automated Inventory Program (AIP)
- automatically include the data in the CMR

- use the data in reports

Note: You will have to go back to the record to complete the full cataloging at some point. You can't use Backlog Cataloging (BACAT) funds for partially cataloged items.

5. *What if I have unverified data?*

It's important to note when data are unverified. Use a question mark “?” or attributed “(att)” to show data that are probable but not certain.

6. *What if I need to add or change information on the catalog record?*

Cataloging is a continuing process. You may receive additional information about an object, or discover that information on the record is incorrect. You can add, change, or delete information on the catalog record at any time. The Catalog Notes supplemental record in ANCS+ allows you to keep track of changes to the record. Refer to Section II in Chapter 3 of the *ANCS+ User Manual* for information on the Catalog Notes supplemental record. Refer to Section G in this chapter for information on recataloging.

7. *Can I catalog objects that are alike on the same catalog record?*

This depends on the objects. Refer to Appendix I: Lot Cataloging, in this handbook for guidelines on when to lot catalog similar objects. Refer to Appendix C: Recommended Cataloging Guidelines, in this handbook for information on cataloging pairs and sets of objects.

8. *How do I catalog objects with detachable parts?*

Catalog detachable parts as components of the object. Refer to Appendix C: Recommended Cataloging Guidelines, in this handbook for information on cataloging objects with component parts.

9. *Should I photograph objects while I'm cataloging?*

Yes. Photograph most objects as part of the cataloging process. You should have a permanent space in the cataloging area for photographing objects. However, you may have to set up photography sessions as time, staff, and funding permit.

Photographs can aid you in:

- describing an object
- recording condition
- recovering a lost or stolen object
- preserving the object by reducing the need to handle it

A complete record of an object generally requires both a photograph and a catalog record with a cross-reference between the two.

It is highly recommended that you photograph all controlled property:

- *items with a value over \$1,000*
- *firearms*
- *type specimens*
- *incoming loans (with the exception of incoming loans to NPS repositories)*
- *items especially vulnerable to theft, loss, and damage*

Refer to Appendix K: Photography, in this handbook for information on photographing museum collections.

10. *Are there times when I don't need to photograph collections?*

Yes. You must decide if a photograph is useful. For example, you don't need to photograph most botanical specimens, soil samples, or sherds. Photograph culturally affiliated NAGPRA items in consultation with the affiliated tribe.

You can make a photocopy, rather than a photograph, of some archival materials. Use a photocopy if:

- the item is a line drawing or illustration
- there isn't a lot of shading or nuance in the work
- you don't need to capture extremely fine detail
- the material is already a copy (such as a blueprint drawing of an architectural drawing)
- the material doesn't have high artifactual or evidential value

11. *When do I mark an object with a catalog number?*

Mark the object with a catalog number when you complete the worksheet or catalog record. Placing a catalog number on the object links the object to its documentation. Refer to Appendix J: Marking and Numbering Museum Collections, in this handbook for marking techniques.

Mark objects with the complete catalog number, which includes the park acronym, a space (or collection designator), and a sequential identification number. For example: DETO 3717.

A catalog number never includes a hyphen between the acronym and the number.

Be sure to enter the catalog number on the natural history labels for natural history specimens. You can't mark the number on many natural history specimens, such as insects or soils.

Mark catalog numbers on folder and box labels for archival collections.

Don't place a number on incoming loans. Use an acid-free tag to label incoming loans with a catalog number. NPS centers may mark numbers on park collections that are on loan to the center for curation and storage.

12. *What do I do with catalog data that I receive from centers, contractors, and other sources outside the park?*

The catalog data you receive from centers, contractors, and other outside sources is part of your park's database. You must transfer the data into the park database and submit the complete database to the National Catalog every year. A complete database for your park includes the data for all the objects that the park owns. By law and regulation, the park is responsible for archeological and natural history collections that are collected at the park. The park must maintain catalog data on these collections even if the collections are not located at the park. (Before 1984, parks weren't required to catalog natural history specimens that were collected under permit and stored in other repositories.)

13. *What is the relationship between the NPSpecies database and my catalog records?*

The NPSpecies database of the Inventory and Monitoring (I & M) Program uploads data from your ANCS+ natural history catalog records. You can give your data directly to I & M or have the National Catalog give them your data. The park must give the National Catalog permission to send your data to the I & M Program.

Note: Upload data from ANCS+ to NPSpecies. Don't upload data from NPSpecies to ANCS+.

D. Tracking Catalog Numbers

1. *Can I release catalog numbers in advance?*

Yes. You may need to give or release catalog numbers to other institutions or individuals that are responsible for cataloging NPS collections. These include:

- NPS centers, such as the Midwest Archeological Center (MWAC)
- universities
- non-NPS museums or institutions
- contractors
- collectors (collecting under permit)

You may also release catalog numbers in advance if you have a large cataloging staff. Assigning blocks of numbers to each individual is a good way to track your catalog numbers.

ANCS+ has a pre-allocate records function that assigns catalog numbers to blank records. Refer to Section IV in Chapter 6 of the *ANCS+ User Manual* for information on this function.

2. *When should I release catalog numbers outside the park?*

The repository, contractor, or collector must give you a list or estimate of the items to be cataloged. Don't release catalog numbers until you receive an adequate estimation of the material. Make sure that the person cataloging the material has a copy of:

- the appropriate chapters and appendices in this handbook and the *ANCS+ User Manual*
- a copy of ANCS+

- site-specific cataloging guidelines, if available

Use of the program and guidelines should be part of the contract or permit requirements. Refer to the introduction of the *ANCS+ User Manual* for information on contractors and the use of ANCS+.

If you don't require contractors to use ANCS+, be sure they provide the data for all mandatory fields. The data should be in an export format that you can easily import into ANCS+. See Section VI in Chapter 6 of the *ANCS+ User Manual* for information on importing and exporting data.

3. *How should I track the catalog numbers I release?*

Use a bound catalog number logbook or a computer-generated log to track catalog numbers. See Figure 3.3 for a sample logbook page. Be sure to include an "Issued To" column or field to note who has the number. For large collecting projects that use hundreds of catalog numbers, placing lists of catalog numbers in the accession folder for the project is helpful.

Make sure that all the numbers you release have been used and properly assigned to objects. This may be difficult since you may not know which numbers were used for several years. You will also want to keep track of which numbers were not used. You can then reassign these numbers to other objects.

4. *How can I find the last catalog number I used?*

If you don't keep a catalog number log, you will have to check ANCS+ or your catalog worksheets for the last number.

<i>If...</i>	<i>Then...</i>
all your records are in ANCS+,	go to the last record in your database (remember to check both the CR and NH databases) and sort your data by catalog number.
you have catalog worksheets waiting for data entry,	look for the catalog number on the last completed worksheet.

Remember that you may have already released catalog numbers that aren't in the database or on worksheets. Also, catalogers may be using skipped numbers. The catalog number on the last completed worksheet may not be the actual last number. You risk fewer errors by keeping a logbook.

Use the missing numbers report in ANCS+ to find missing numbers in the database.

5. *May I reuse catalog numbers?*

Reusing catalog numbers depends on the circumstances. If an object was cataloged under two different numbers, you can void the later number and reuse it. When you reuse the number, make a cross-reference to its earlier use. For example, you can note, "This catalog number was previously used for chair XXXX 567. The chair had been cataloged twice by mistake."

Never reuse catalog numbers for missing or deaccessioned objects.

6. *What if I have missing catalog numbers?*

If you skip a catalog number by mistake, assign the number to the next available object. You may have to spend some time searching for missing numbers if you have released numbers in advance.

7. *What if I have duplicate catalog numbers?*

<i>If the duplicate catalog numbers are for...</i>	<i>Then...</i>
identical records,	delete one of the records.
different objects,	assign a new number to one of the objects with a cross-reference to the old number.

Be sure to check the catalog numbers on the objects as well as the catalog records.

8. *How should I cross-reference catalog numbers with the accession records?*

For small accessions, enter the catalog numbers in the Catalog Number column in the accession book. Leave this column blank for large accessions.

Add the catalog numbers to the list of objects or inventory list that is part of the Accession Receiving Report, Form 10-95. This provides a good cross-reference between your accession and catalog records. Be sure to date the list to make clear that it was completed after the accession receiving report.

You can also generate a list from ANCS+ of all the cataloged items in an accession. Add this list to the accession file in place of a written list.

E. Cultural Resources (CR) Catalog Data Fields

1. *Where do I find the data fields for CR catalog records?*

The data fields for your CR catalog records are in the Collections Management Module of ANCS+. This module has your accession records and your cultural resources and natural history catalog records. It also has associated modules that help you with collections management functions, such as outgoing loans.

2. *What are the data fields for CR catalog records?*

The following list of CR data fields includes the mandatory fields. You can't save a record in ANCS+ until you complete all the mandatory fields. Refer to questions 3-6 of this section for discipline-specific fields. Refer to Chapter 2 in the *ANCS+ User Manual* and the on-line help in ANCS+ for information on how to use and complete the fields.

Sample catalog records for archeology, ethnology, history, and archival/manuscript collections appear in Figures 3.4 – 3.7.

* Mandatory Field

@ ANCS+ enters "Not Provided" if you don't complete this field.

+ ANCS+ enters "Not Provided" in all these fields if you don't complete at least one of them for archeology records.

* Accession Number

- Alternate Name
- Artist/Maker
- Catalog Date
- Catalog Folder
- * Catalog Number
- * Cataloger
- * Classification Lines 1-4
- Component Part
- * Condition
- Condition Description
- * Controlled Property
- Cultural ID
- Culture of Use
- @ Description
- Eminent Figure
- Eminent Organization
- + Field Site Number
- Historic/Cultural Period
- Identified By
- Identified Date
- * Item Count (or Quantity)
- Key Descriptor
- * Location
- Maintenance Cycle
- Manufacture Date
- Material
- Measurements
 - Dimensions
 - Other
 - Volume
 - Weight
- NAGPRA
- * Object Name
- * Object Status
- Other
- Other Numbers
- Place of Manufacture
 - City
 - Country
 - County
 - State
- Place of Origin
 - City
 - Country
 - County
 - State
- * Quantity (or Item Count)
- Related Collections
- Reproduction
- + Site Name
- + State Site Number
- * Status Date
- * Storage Unit
- Use Date
- + Within Site Provenience

3. *What are the discipline-*
NPS Museum Handbook, Part II (2000)

The following list of fields appears on the discipline-specific screen in

specific fields for archeology records?

ANCS+. None of these fields are mandatory.

Collector
Collection Date
Collector
Color
Decorative Motif
Decorative Technique
Field Specimen Number
Makers Mark
Manufacturing Technique
Object Form
Object Part
Previous Catalog Number
Revised Nomenclature
Temper
Type Name

4. *What are the discipline-specific fields for ethnology records?*

The following list of fields appears on the discipline-specific screen in ANCS+. None of these fields are mandatory.

Aboriginal Name
Additional Area
Additional Group
Manufacturing Technique
Object Use
Possible/Probable Classification

5. *What are the discipline-specific fields for history records?*

The following list of fields appears on the discipline-specific screen in ANCS+. None of these fields are mandatory.

Copyright
Format
Genre
Inscription/Marks
Object Use
Patent Date
Process/Technique of Manufacture
School
Significant Event
Style
Subjects
Term (AAT)
Title

Note: ANCS+ contains the lexicon for the *Art and Architecture Thesaurus (AAT)*. The AAT is a standardized vocabulary for fine arts, architecture, decorative art, and material culture of the Western world.

6. *What are the discipline-specific fields for archival/manuscript records in the Collections Management Module?*

The following list of fields appears on the discipline-specific screen in ANCS+. None of these fields are mandatory.

- Additional Accession Numbers
- Arrangement
- Catalog Level
- Collection Title
- Dates
 - Bulk Dates
 - Inclusive Dates
- Finding Aids
 - Finding Aid
 - Level of Control
- History
- Index Terms
 - Form
 - Function
 - Genre
 - Occupation
- Language
- Local Collection Number
- Organization
- Provenance
- Reference Terms
 - Corporate Name
 - Geographic Name
 - Personal Name
 - Topic

7. *What is the Archives Module in ANCS+?*

The Archives Module is a separate but interfacing element of ANCS+. It allows you to describe archival collections beyond the catalog information in the Collections Management Module. The Archives Module allows you to describe archival collections:

- at multiple levels (collection, series, file unit, and item levels)
- according to archival descriptive standards
- in the Machine Readable Cataloging (MARC) format

Note: Use of the MARC format allows you to upload records into national bibliographic systems.

8. *Must I catalog all archival/manuscript collections in the ANCS+ Archives Module?*

No. The archival survey and processing plan will recommend which collections should be further described in the Archives Module.

You must catalog all archival collections in the Collections Management Module. ANCS+ will copy the information in the Collections Management Module to the Archives Module if you choose to do so.

For some collections, you may decide to use the Archives Module to create a more detailed collection level record. You can then further describe the collection at the series, file unit, and item levels. Refer to Appendix I, Archives Module, in the *ANCS+ User Manual* for information on the data fields in the Archives Module. Refer to Appendix D in this handbook for guidance on archival surveys and processing plans.

9. *Where can I find information about the CR discipline classifications?*

Refer to the appendices in this handbook for information on classifying and naming archeology, ethnology, and history objects and archival/manuscript collections. Figure 3.11 is a flow chart showing CR classifications.

Appendix D: Archival & Manuscript Collections

Appendix E: Archeology

Appendix F: Ethnology

Appendix G: History

**F. Natural History (NH)
Catalog Data Fields**

1. *Where do I find the data fields for NH catalog records?*

The data fields for your NH catalog records are in the Collections Management Module of ANCS+. This module has your accession records and your cultural resources and natural history catalog records. It also has associated modules that help you with collections management functions, such as outgoing loans.

2. *What are the data fields for NH catalog records?*

The following list of NH data fields includes the mandatory fields. You can't save a record in ANCS+ until you complete all the mandatory fields. Refer to questions 3-5 of this section for discipline-specific fields. Refer to Chapter 2 in the *ANCS+ User Manual* and the on-line help in ANCS+ for information on how to use and complete the fields.

Sample catalog records for biology, geology, and paleontology appear in Figures 3.8 – 3.10.

* Mandatory Field

@ ANCS+ enters "Not Provided" if you don't complete this field.

+ You must enter either Latitude and Longitude, Township/Range/Section, or UTM Coordinates.

* Accession Number

Catalog Date

Catalog Folder

* Catalog Number

* Cataloger

* Classification Lines 1-4

* Collection Date

@ Collection Number

@ Collector

Common Name

Component Part

* Condition

Condition Description

* Controlled Property

County

Depositional Environment
 Depth
 Description
 Dimensions/Weight
 Elevation
 Eminent Figure
 Eminent Organization
 * Identified By
 Identified Date
 * Item Count (or Quantity)
 + Latitude and Longitude
 Locality
 * Location
 Maintenance Cycle
 * Object Status
 Other Numbers
 Park
 * Quantity (or Item Count)
 Reproduction
 * Scientific Name
 State
 * Status Date
 * Storage Unit
 + Township/Range/Section
 + UTM Coordinates
 Waterbody/Drainage

3. *What are the discipline-specific fields for biology records?*

The following list of fields appears on the discipline-specific screen in ANCS+. None of these fields are mandatory.

Age
 Aspect
 Associated Species
 Exotic/Native
 Formation/Period/Substrate
 Habitat
 Habitat/Community
 Lower Taxon
 Rare
 Sex
 Slope
 Soil Type
 Threatened/Endangered Date
 Threatened/Endangered Species
 Synonym
 Synonym Name
 Threatened and Endangered Status
 Type Specimen

4. *What are the discipline-specific fields for geology records?*

The following list of fields appears on the discipline-specific screen in ANCS+.

* Mandatory Field

@ ANCS+ enters “Not Provided” if you don’t complete this field.

Age/Stage
Datum
Epoch/Series
* Formation
Lithology/Pedotype
Member
@ Period/System
Thin Section
Unit
Vertical Datum

5. *What are the discipline-specific fields for paleontology records?*

The following list of fields appears on the discipline-specific screen in ANCS+.

@ ANCS+ enters “Not Provided” if you don’t complete this field.

Age/Stage
Datum
Epoch/Series
Formation
Horizon
In situ/Float
Lithology
Lower Taxon
Member
@ Period/System
Taphonomy
Type Specimen
Unit
Vertical Datum

6. *Where can I find information about the NH classifications and cataloging?*

Refer to Appendix H: Natural History for information on classifying and naming biology, geology, and paleontology specimens. Appendix H is an appendix of this handbook, but it is published in a separate volume. It includes the Hierarchical Classification Outline (HCO) for classifying specimens, a scientific name index, and a common name index.

Figure 3.12 is a flow chart showing NH classifications.

G. Making Changes on the Catalog Record

1. *How do I make and track changes to a catalog record?*

Modify the record in ANCS+. When you save the record, the program will prompt you for the level of changes you have made. Choose between:

- Minor Modification, such as a change in location
- Recataloged, such as a change in object name

The optional Catalog Notes supplemental record allows you to note the changes you made. You can track changes to the catalog record, when they were made, and who made them. Refer to information on saving a catalog record in Chapter 2 of the *ANCS+ User Manual*. Refer to Section II in Chapter 3 of the *ANCS+ User Manual* for information on the Catalog Notes supplemental record.

If you keep paper records at the park, have the National Catalog print the records you have changed. Draw a diagonal line through the old record, and place the new record on top. If you keep catalog folders, you may place the old record in the appropriate catalog folder.

2. *How do I change manual records that are not in ANCS+?*

For minor modifications to records that are not yet in ANCS+, write the correction on the record. Include the name of the person who authorized the change and the date of change.

If you are recataloging (see definition below) a manual record, enter the record into ANCS+.

Note: Entering a manual catalog record into ANCS+ without changes is not considered to be recataloging.

3. *What is recataloging?*

Recataloging is any significant change to the data in the catalog record.

Examples: an appraiser tells you that an object is a reproduction

a specialist changes the scientific name of a botany specimen

you deaccession an object

Changes in location and object status (other than deaccessioning), and correction of spelling errors are not recataloging.

In general, when you make changes to the following fields, you are recataloging:

- Accession Number
- Catalog Number
- Item Count or Quantity
- Object Status (if deaccessioned)
- NAGPRA (CR records)
- Classification
- Object Name or Scientific Name
- Description (if substantial changes for CR records)
- Site of Original Collection/Provenience fields (for archeology)
- Manufacture Date (CR records)
- Eminent Figure Association and Eminent Organization (CR records)
- Artist/Maker (CR records)
- Reproduction (CR records)

- Collector, Collection Number, Collection Date (NH records)
- Collection Site Data (NH records)

4. *Do I submit the records I changed to the National Catalog?*

Yes. Each year you must submit a copy of your entire database to the National Catalog. You must also submit a tag file of the catalog records you completed during the fiscal year. If you recataloged records during the fiscal year, include these records in the tag file. Refer to Section VII of Chapter 7 in the *ANCS+ User Manual* for information on preparing records for your annual submission.

Don't include records with minor modifications, such as location changes, in the tag file with the new and recataloged records.

5. *Does the National Catalog print archival copies of recataloged records?*

Yes. National Catalog staff will print and store white, archival copies of the recataloged records. You can request that the National Catalog print blue, park copies of recataloged records for the park.

6. *Does the National Catalog print archival copies of records with minor modifications?*

No. The National Catalog doesn't print or store archival copies of records with minor modifications.

The National Catalog will print blue, park copies of records with minor modifications if you:

- make a separate tag file of the records with minor modifications that you want to print, and
- request the blue copies

For example, you might want new blue copies of your catalog records after a mass location change.

7. *Can I make changes to the NPS classification systems?*

No. The classification tables in ANCS+ are locked tables. You may not add to, delete, or modify the NPS classification entries. The Museum Management Program may periodically update these tables in consultation with discipline-specific specialists. Send requests and justifications for changes in classification to the Museum Registrar, National Catalog. Refer to Appendix H: Natural History, in this handbook for information on requesting additions to the Hierarchical Classification Outline (HCO).

8. *Can I make changes to the object name lists?*

Yes. You can make changes to all of the object/scientific name lists in ANCS+ except the history object term list. The Museum Management Program will periodically update the history object term list in consultation with discipline-specific specialists. Refer to Appendix G: History, in this handbook for information on requesting additions to the history object term list.

H. Submitting Catalog Records to the National Catalog

1. *Must I submit catalog records to the National Catalog?*

Yes. Each year you must submit a copy of your ANCS+ database to the National Catalog in Harpers Ferry, West Virginia. You must submit a copy of your database even if your park had no cataloging activity during the

year.

<i>If you...</i>	<i>Then...</i>
had cataloging activity during the fiscal year,	your database needs to include tag files that contain the fiscal year's catalog records (new and recataloged records).
don't have any electronic records at the park,	please send a memo stating that you don't have a database to submit.

Don't submit paper records to the National Catalog. The National Catalog staff will print white and, if requested, blue paper copies of your records.

2. *Why must I submit my catalog records to the National Catalog?*

The National Catalog is one of the required NPS inventories and databases. It provides:

- off-site storage for your electronic data
- paper copies of your catalog records that serve as backups to your electronic data
- a centralized source of information about NPS museum catalog data

The NPS doesn't consider an object cataloged until you submit the catalog record to the National Catalog.

Note: You should keep a complete, current backup at the park of all accession and catalog records. Refer to Section VII in Chapter 7 of the *ANCS+ User Manual* for backup instructions.

3. *When do I submit my database to the National Catalog?*

Submit your database in the month for your region's submission:

November: Midwest Region, Southeast Region, Harpers Ferry Center, Washington Office

December: Alaska Region, Intermountain Region, Denver Service Center

January: National Capital Region, Northeast Region, Pacific West Region

4. *What do I submit to the National Catalog?*

You need to submit a:

- copy of your entire database on a zip disk, including both CR, NH, and accession records
- tag files that contain the new and recataloged records that you completed during the previous fiscal year (October 1-September 30)

- Receipt for Property, DI-105 that includes a list of the numbers in the tag file
- cover memo indicating if you want the National Catalog to print and return blue copies of the catalog records.
- self-addressed label for return of the receipt for property

Note: If no cataloging activity took place during the fiscal year, you don't need to make tag files.

5. *How do I prepare the data for submission?*

Refer to the *ANCS+ User Manual* for instructions on how to back up your data and create a tag file for submission. See:

- Section VII of Chapter 7 for instructions on how to back up your database
- Section XI of Chapter 6 for information on tag files

6. *How do I prepare the receipt for property?*

Include the following on the receipt for property:

- park name or acronym
- the number of zip disks that you have enclosed
- the name and title of the person issuing the submission and the date of issue
- the ranges of consecutive catalog numbers in the tag file, such as 590-789, 800-867

Don't include ranges of non-consecutive numbers.

Note: If you have a lot of non-consecutive numbers in your tag file, print a receipt for property from ANCS+. The receipt will list every number in the tag file. Refer to Section II of Chapter 5 in the *ANCS+ User Manual* for information on printing a receipt for property.

Refer to Figure 3.13 for a sample receipt for property.

7. *Where do I send my submission?*

Mail your submission to:

National Park Service
National Catalog
Bombshelter/Fillmore Street
Harpers Ferry, WV 25425

Mail submissions by:

- certified U.S. mail
- United Parcel Service

- Federal Express
- other reputable mail service

Don't send submissions by cc:Mail.

8. *What happens to my records at the National Catalog?*

The National Catalog staff will:

- sign and return your receipt for property
- log in your records and print reports from your database and tag file
- print white, archival copies of your new and recataloged records and store them in the National Catalog vault
- print blue copies of your catalog records at your request
- send you copies of the reports

9. *What should I do with the blue copies of my catalog records?*

Many parks still use paper records along with their ANCS+ database. In the NPS these records are blue to distinguish them from the white archival records at the National Catalog. File these blue records consecutively by catalog number in groups of five hundred, with the highest number on top. Place them in post binders that are available from the Supply and Equipment Program of the Museum Management Program. Most parks keep these records in the curatorial office or collection storage area for quick reference when working with the collection.

10. *Does the National Catalog print white cardstock classification copies of catalog records?*

No. The NPS no longer uses the white cardstock classification copy of the Form 10-254. Some parks with large numbers of manual records may still maintain a classification file for these records. It's a file based on the classification headings and sub-headings for objects in a collection. The use of classification files will become obsolete when all the manual records have been entered into ANCS+. Classification searches will then be done more efficiently by the computer.

I. List of Figures

Figure 3.1	Museum Catalog Record - CR, Form 10-254 Rev.
Figure 3.2	Museum Catalog Record - NH, Form 10-254B Rev.
Figure 3.3	Catalog Number Logbook Page (Sample)
Figure 3.4	Archeology Catalog Record (Sample)
Figure 3.5	Ethnology Catalog Record (Sample)
Figure 3.6	History Catalog Record (Sample)
Figure 3.7	Archival/Manuscript Catalog Record (Sample)
Figure 3.8	Biology Catalog Record (Sample)
Figure 3.9	Geology Catalog Record (Sample)
Figure 3.10	Paleontology Catalog Record (Sample)
Figure 3.11	Cultural Resources Classification
Figure 3.12	Natural History Classification
Figure 3.13	Receipt for Property, DI-105 (Sample)

MUSEUM CATALOG RECORD-CR		MUSEUM CATALOG RECORD - CULTURAL RESOURCES	
REGISTRATION DATA		NATIONAL PARK SERVICE FORM 10-254 REV. 7/84	
CLASSIFICATION	OBJECT LOCATION	CONTROLLED PROPERTY	
	OBJECT STATUS AND YEAR	PARK ACRONYM	CATALOG NUMBER
	ACQUISITION TYPE	ACQUISITION DATE	ACCESSION NUMBER
OBJECT		LOT QUANTIFICATION	STORAGE UNIT
		ITEM COUNT	
DESCRIPTION			
SITE OF ORIGINAL COLLECTION/PROVENIENCE	SITE OF ORIGIN		
CULTURAL IDENTITY	OBJECT DATE	HISTORIC / CULTURAL PERIOD	
DIMENSIONS/WEIGHT	PHOTO NUMBER	OTHER NUMBERS	
MEDIUM/MATERIALS		CONDITION	MAINTENANCE CYCLE
IDENTIFIED BY AND DATE	EMINENT FIGURE ASSOCIATION	ARTIST/MAKER	
CATALOGER AND DATE	VALUE AT ACQUISITION, BASIS	CURRENT VALUE, DATE, BASIS	
RESTRICTION	REPRODUCTION	PUBLICATION CITATION	PRESERVATION TREATMENT
U.S. DEPARTMENT OF THE INTERIOR		CATALOG FOLDER	SIGNIFICANCE

Figure 3.1. Museum Catalog Record-CR, Form 10-254 Rev.

CLASSIFICATION		OBJECT LOCATION		CONTROLLED PROPERTY	
REGISTRATION DATA		MUSEUM CATALOG RECORD-NH		CATALOG DATA	
OBJECT STATUS AND YEAR		PARK ACRONYM		CATALOG NUMBER	
ACQUISITION TYPE		ACQUISITION DATE		ACCESSION NUMBER	
OBJECT/SPECIMEN NAME		ITEM COUNT		LOT QUANTIFICATION STORAGE UNIT	
DESCRIPTION					
COLLECTION SITE		PARK		TOWNSHIP/RANGE/SECTION COUNTY STATE	
WATERBODY/DRAINAGE		UTM Z/E/N		LAT. LONG. ELEVATION DEPTH	
HABITAT/DEPOSITIONAL ENVIRONMENT		FORMATION-PERIOD		DIMENSIONS/WEIGHT	
COLLECTOR		COLLECTION NO.		COLLECTION DATE MAINTENANCE CYCLE CONDITION	
IDENTIFIED BY AND DATE		TYPE		VALUE AT ACQUISITION, BASIS CURRENT VALUE, DATE, BASIS PHOTO NUMBER	
CATALOGER AND DATE		EMINENT FIGURE ASSOCIATION		OTHER NUMBERS	
RESTRICTION		REPRODUCTION		PUBLICATION CITATION	
PRESERVATION TREATMENT		CATALOG FOLDER		SIGNIFICANCE	
U.S. DEPARTMENT OF THE INTERIOR		MUSEUM CATALOG RECORD - NATURAL HISTORY		NATIONAL PARK SERVICE	
				FORM 10-254B REV. 7/84	

Figure 3.2. Museum Catalog Record-NH, Form 10-254B Rev.

Cat. Nos.	Acc. No.	Issued To	Date Issued	Object(s)

Figure 3.3. Catalog Number Logbook Page (Sample)

MUSEUM CATALOG RECORD-CR		CATALOG DATA		REGISTRATION DATA	
CLASSIFICATION ARCHEOLOGY	OBJECT LOCATION SOUTHWEST MUSEUM RM 10 BX 901 B SH I-9-D	CONTROLLED PROPERTY N			
PREHISTORIC	OBJECT STATUS AND YEAR STORAGE 1999	PARK ACRONYM PARK	CATALOG NUMBER 8254	NUMBER	
MINERAL	ACQUISITION TYPE FIELD COLLECTION	ACQUISITION DATE 09/01/1988	ACCESSION NUMBER PARK-00018		
STONE	OBJECT	ITEM COUNT 4	LOT QUANTIFICATION	STORAGE UNIT EA	
ABRADER	DESCRIPTION 1 TRIANGULAR AND 3 IRREGULAR SHAPED TABULAR SANDSTONE ABRADER FRAGMENTS WITH THE TRIANGULAR PIECE ABRADED ON ONE FACE AND APPEARING TO HAVE BEEN BURNED; THE IRREGULAR SHAPED PIECES HAVE BEEN GROUND SMOOTH ON BOTH FACES AND TWO OF THESE FRAGMENTS FIT TOGETHER. BAG NOTE: BOOTH 5				
SITE OF ORIGINAL COLLECTION/PROVENIENCE 27SI 423 LA 878 TM 2, STRAT COLUMN 8, GSQ 278(NE 1/4), LY 34		SITE OF ORIGIN			
CULTURAL IDENTITY ANASAZI	OBJECT DATE AD 1020-1140	HISTORIC / CULTURAL PERIOD PII-PIII			
DIMENSIONS/WEIGHT L 6.0, W 4.7, T 1.5 CM; L 5.5, W 4.2 T 0.7 CM	PHOTO NUMBER	OTHER NUMBERS FS 4659			
MEDIUM/MATERIALS SANDSTONE	EMINENT FIGURE ASSOCIATION				
IDENTIFIED BY AND DATE RICARDO, VICTOR 10/20/1988	CURRENT VALUE, DATE, BASIS				
CATALOGER AND DATE SANDERS, NANCY 06/16/1999	VALUE AT ACQUISITION, BASIS	PRESERVATION TREATMENT			
RESTRICTION N	REPRODUCTION N	PUBLICATION CITATION N	PRESERVATION TREATMENT N	CATALOG FOLDER	SIGNIFICANCE N
U.S. DEPARTMENT OF THE INTERIOR					
MUSEUM CATALOG RECORD - CULTURAL RESOURCES					
NATIONAL PARK SERVICE FORM 10-254 REV. 7/84					

Figure 3.4. Archeology Catalog Record (Sample)

MUSEUM CATALOG RECORD-CR		REGISTRATION DATA		CATALOG DATA		CONTROLLED PROPERTY	
CLASSIFICATION	OBJECT LOCATION	CR-61-A-1		PARK ACRONYM		Y	
ETHNOLOGY	OBJECT STATUS AND YEAR	STORAGE 1999		PARK		NUMBER	
BASIN	ACQUISITION TYPE	GIFT		ACQUISITION DATE		NUMBER	
MONO LAKE PAIUTE				07/23/1997		PARK-00579	
GLASS/PLANT				LOT QUANTIFICATION			
OBJECT				ITEM COUNT		STORAGE UNIT	
BASKET, BEADED				1		EA	
DESCRIPTION	BEAD-COVERED SINGLE ROD BASKET, WOVEN IN SPLIT WILLOW SHOOTS, WITH 4 HORIZONTAL BANDS OF BLACK BRACKEN FERN ROOT. THE BASKET IS COVERED WITH NET-BEADING USING 4/0 ITALIAN & 11/0 CZECHOSLOVAKIAN BEADS IN A LIGHT BLUE BACKGROUND, WITH VARIOUS VERTICAL ZIGZAGS, TREE-LIKE MOTIFS, AND FLAME-LIKE PATTERNS WORKED IN OPAQUE WHITE, BLACK, AND RED-ORANGE, AND TRANSPARENT RED, DARK BLUE, AND GREEN. THIS BASKET WAS EXHIBITED AT THE 1925 INDIAN FIELD DAYS BY BELLE JOSEPH (SEE PHOTO ALBUM PARK 46106).						
SITE OF ORIGINAL COLLECTION/PROVENIENCE	SITE OF ORIGIN						
---	MONO/LEE VINING -- CA -- USA						
CULTURAL IDENTITY	OBJECT DATE	HISTORIC / CULTURAL PERIOD					
MONO LAKE PAIUTE	1925						
DIMENSIONS/WEIGHT	PHOTO NUMBER	OTHER NUMBERS					
H 7.8, DIAM 14.0 CM	567/4						
MEDIUM/MATERIALS	EMINENT FIGURE ASSOCIATION		CONDITION		MAINTENANCE CYCLE		
WILLOW --GLASS BEADS --COTTON THREAD	JOSEPH, BELLE		COM/GD		1.5/1999		
IDENTIFIED BY AND DATE	MOBLEY, EARL 08/24/1997		ARTIST/MAKER		JOSEPH, BELLE		
CATALOGER AND DATE	MOBLEY, EARL 08/24/1997		CURRENT VALUE, DATE, BASIS		\$2000 03/22/2000 MARKET		
RESTRICTION	REPRODUCTION	PUBLICATION CITATION	PRESERVATION TREATMENT	CATALOG FOLDER	SIGNIFICANCE	N	
Y	N	N	Y	N	N	N	
U.S. DEPARTMENT OF THE INTERIOR							
MUSEUM CATALOG RECORD - CULTURAL RESOURCES							
NATIONAL PARK SERVICE							
FORM 10-254							
REV. 7/84							

Figure 3.5. Ethnology Catalog Record (Sample)

MUSEUM CATALOG RECORD-CR		REGISTRATION DATA	
CLASSIFICATION HISTORY	OBJECT LOCATION WYLER HOUSE DINING RM	CONTROLLED PROPERTY Y	
FURNISHINGS	OBJECT STATUS AND YEAR EXHIBIT 1999	PARK ACRONYM PARK	CATALOG NUMBER 7621
FURNITURE	ACQUISITION TYPE GIFT	ACQUISITION DATE 12/08/1998	ACCESSION NUMBER PARK-00044
OBJECT		LOT QUANTIFICATION	STORAGE UNIT
CHAIR		ITEM COUNT 1	EA
DESCRIPTION	MAHOGANY HEPPLEWHITE SHIELD-BACK SIDE CHAIR WITH SWELLED ORIGINAL SLIPSEAT AND MOLDED EXTERIOR FRONT LEGS. SHIELD BACK CONTAINS FIVE CHanneled VERTICAL SLATS SPRINGING FROM A LEAF CARVED AND 15 FLUTE LUNETTE, TERMINATING IN A STYLIZED LOTUS FLOWER AND CROSS-HATCHING. MARKED ON INTERIOR FRONT SEAT RAIL "IIIIIV". BRASS PLATE SAYS: "THIS CHAIR BELONGED TO REV. THOMAS WYLER, FRANKLIN PRESBYTERIAN CHURCH."		
SITE OF ORIGINAL COLLECTION/PROVENIENCE	SITE OF ORIGIN HOPEWELL, ___ PA ___ USA		
CULTURAL IDENTITY	OBJECT DATE 1787 --AD --CIRCA	HISTORIC / CULTURAL PERIOD FEDERAL	
DIMENSIONS/WEIGHT H 99.1, W 54.3, D 56.0 CM ___ ___ ___	PHOTO NUMBER 4235/13	OTHER NUMBERS	
MEDIUM/MATERIALS WOOD		CONDITION COM/GD	MAINTENANCE CYCLE 1.0/1999
IDENTIFIED BY AND DATE PARK, MALCOLM 12/08/1998	EMINENT FIGURE ASSOCIATION WYLER, REV. THOMAS		
CATALOGER AND DATE DAI, SHAN 12/10/1998	VALUE AT ACQUISITION, BASIS \$ 8000 CATALOGER	CURRENT VALUE, DATE, BASIS \$8000 04/08/1999 CATALOGER	
RESTRICTION N	REPRODUCTION N	PUBLICATION CITATION N	PRESERVATION TREATMENT Y
U.S. DEPARTMENT OF THE INTERIOR		MUSEUM CATALOG RECORD - CULTURAL RESOURCES	
		CATALOG FOLDER Y	SIGNIFICANCE N
		NATIONAL PARK SERVICE FORM 10-254 REV. 7/84	

Figure 3.6. History Catalog Record (Sample)

MUSEUM CATALOG RECORD-CR		REGISTRATION DATA		CATALOG DATA	
CLASSIFICATION HISTORY	COMMUNICATION ARTIFACTS DOCUMENTARY ARTIFACT ARCHIVAL/MANUSCRIPT COLLECT.	OBJECT LOCATION ARC R 3 S 4	OBJECT STATUS AND YEAR STORAGE 1999 ACQUISITION TYPE GIFT	PARK ACRONYM PARK	CONTROLLED PROPERTY Y
OBJECT	CHI ETA PHI SORORITY, INC. RECORDS			CATALOG NUMBER 678	NUMBER
DESCRIPTION	CHI ETA PHI SORORITY, INC.'S RECORDS DOCUMENT THE ACTIVITIES OF THIS NATIONAL ORGANIZATION OF BLACK NURSES FROM THE 1950'S TO THE PRESENT. THE COLLECTION INCLUDES CORRESPONDENCE, MINUTES, AND PUBLICATIONS. SOME HIGHLIGHTS ARE THE MINUTES, REPORTS, AND WORKBOOKS FROM THE ANNUAL BOULE AND THE FILES RELATING TO CHI ETA PHI'S CHAPTERS AND REGIONS.			ACQUISITION DATE 10/01/1995	ACCESSION NUMBER PARK-00343
				LOT QUANTIFICATION ITEM COUNT	STORAGE UNIT 5.50 LF
SITE OF ORIGINAL COLLECTION/PROVENIENCE		SITE OF ORIGIN			
CULTURAL IDENTITY		OBJECT DATE	1954-1997	HISTORIC / CULTURAL PERIOD	
DIMENSIONS/WEIGHT	5.5 LINEAR FEET	PHOTO NUMBER		OTHER NUMBERS	
MEDIUM/MATERIALS	PAPER			CONDITION	MAINTENANCE CYCLE
IDENTIFIED BY AND DATE	BARCLAY, HILLARY 01/08/1999	EMINENT FIGURE ASSOCIATION		EXCELLENT	4.0/1999
CATALOGER AND DATE	ROGERS, WILLIAM 01/08/1999	VALUE AT ACQUISITION, BASIS		ARTIST/MAKER	CHI ETA PHI SORORITY INC.
RESTRICTION	N	PUBLICATION CITATION	N	PRESERVATION TREATMENT	N
U.S. DEPARTMENT OF THE INTERIOR	MUSEUM CATALOG RECORD - CULTURAL RESOURCES	CATALOG FOLDER	N	SIGNIFICANCE	N
					NATIONAL PARK SERVICE
					FORM 10-254
					REV. 7/84

Figure 3.7. Archival/Manuscript Catalog Record (Sample)

REGISTRATION DATA		CATALOG DATA	
CLASSIFICATION	OBJECT LOCATION	FSU DEPT. ENT. BODNAR INSECT COLL.	
BIOLOGY	OBJECT STATUS AND YEAR	CONTROLLED PROPERTY	
ANIMALIA	LOAN OUT - 1998	PARK ACRONYM	CATALOG NUMBER
INSECTA	ACQUISITION TYPE	PARK	13932
LEPIDOPTERA	FIELD COLLECTION	ACQUISITION DATE	ACCESSION NUMBER
		09/15/1998	PARK-00846
OBJECT/SPECIMEN NAME	BEET WEBWORM	LOT QUANTIFICATION	STORAGE UNIT
<i>Loxostege sticticalis</i>		ITEM COUNT	EA
DESCRIPTION	PINNED SPECIMEN.		
	FAMILY: PYRALIDAE		
COLLECTION SITE	PARK	TOWNSHIP/RANGE/SECTION	COUNTY STATE
TWIN OWLS TRAILHEAD			
WATERBODY/DRAINAGE	PARK	T. 5N. R. 73W. Sec. 13.	LARIMER CO
UNNAMED CREEK TO BLACK CANYON CREEK		LONG.	DEPTH
			2385 M
HABITAT/DEPOSITIONAL ENVIRONMENT	FORMATION/PERIOD	DIMENSIONS/WEIGHT	
OPEN PONDERSOA PINE, BOREAL SHRUB-GRASSLAND, ASPEN RIPARIAN		L 2.5 CM	
COLLECTOR	COLLECTION NO.	COLLECTION DATE	MAINTENANCE CYCLE
VALARDI, ANGELO	P065	07/17/1998	5.0/1997
IDENTIFIED BY AND DATE	TYPE	VALUE AT ACQUISITION, BASIS	PHOTO NUMBER
VALARDI, ANGELO 07/17/1998	N	CURRENT VALUE, DATE, BASIS	
CATALOGER AND DATE	EMINENT FIGURE ASSOCIATION		
ZUBECK, CONNIE 10/02/1998	OTHER NUMBERS		
RESTRICTION	REPRODUCTION	PUBLICATION CITATION	PRESERVATION TREATMENT
U.S. DEPARTMENT OF THE INTERIOR			
MUSEUM CATALOG RECORD - NATURAL HISTORY NATIONAL PARK SERVICE			
FORM 10-254B			
REV. 7/84			

Figure 3.8. Biology Catalog Record (Sample)

MUSEUM CATALOG RECORD-NH		REGISTRATION DATA		CATALOG DATA	
CLASSIFICATION	OBJECT LOCATION	GEOL CAB #1/DR B		CONTROLLED PROPERTY	
GEOLOGY	OBJECT STATUS AND YEAR	1998		N	
ROCKS	STORAGE	PARK		CATALOG NUMBER	
IGNEOUS	ACQUISITION TYPE	FIELD COLLECTION		6232	
ANDESITE-BASALT GROUP	ACQUISITION DATE	04/28/1998		ACCESSION NUMBER	
OBJECT/SPECIMEN NAME	ITEM COUNT	2		PARK-00778	
BASALTIC ANDESITE OR BASALT? ___	LOT QUANTIFICATION			STORAGE UNIT	
				EA	
DESCRIPTION	DARK GRAY, HIGHLY VESICULAR. MAY REPRESENT TOP OF FLOW (STRATIGRAPHICALLY ABOVE LAVA REPRESENTED BY PARK 6231). NEAR VOLCANIC VENT (ASSOCIATED WITH SCORIA, REPRESENTED BY SAMPLE PARK 6233). 14-17 m. Tbat MEMBER. THIN SECTION.				
COLLECTION SITE	PARK	TOWNSHIP/RANGE/SECTION	COUNTY	STATE	
0.9 MILES ESE OF MILEPOST 71, HIGHWAY 85	PARK	T. 22N. R. 5W. Sec. 12.	CORTEZ	AZ	
WATERBODY/DRAINAGE	UTM Z/E/N	LAT.	LONG.	ELEVATION	DEPTH
				1476 M	
HABITAT/DEPOSITIONAL ENVIRONMENT	FORMATION PERIOD		DIMENSIONS/WEIGHT		
	BATOMITE AND ESITE/TERTIARY		748.3 G		
COLLECTOR	COLLECTION NO.	COLLECTION DATE	MAINTENANCE CYCLE	CONDITION	
CHAMP, EDWARD	OP 78-A	04/01/1998	9.0/1998	COM/EX	
IDENTIFIED BY AND DATE	TYPE	VALUE AT ACQUISITION, BASIS	CURRENT VALUE, DATE, BASIS	PHOTO NUMBER	
CHAMP, EDWARD 05/01/1998	N			75/5	
CATALOGER AND DATE	EMINENT FIGURE ASSOCIATION		OTHER NUMBERS		
INGELLS, JAN 05/08/1998					
RESTRICTION	REPRODUCTION	PUBLICATION CITATION	PRESERVATION TREATMENT	CATALOG FOLDER	SIGNIFICANCE
N	N	N	N	N	N
U.S. DEPARTMENT OF THE INTERIOR			MUSEUM CATALOG RECORD - NATURAL HISTORY		
			NATIONAL PARK SERVICE		

FORM 10-254B
REV. 7/84

Figure 3.9. Geology Catalog Record (Sample)

MUSEUM CATALOG RECORD-NH

REGISTRATION DATA

CLASSIFICATION PALEONTOLOGY UNKNOWN FORMATION MAMMALIA ELEPHANTIDAE	OBJECT LOCATION BLDG 1 RM J2 CAB G DR 1	CONTROLLED PROPERTY N
OBJECT/SPECIMEN NAME Mammuthus ___ columbi ___ Falconer ___ 1857 ___ FEMUR MISSING PROXIMAL CONDYLE.	OBJECT STATUS AND YEAR STORAGE 1997	PARK ACRONYM PARK 2356
	ACQUISITION TYPE FIELD COLLECTION	ACQUISITION DATE 08/08/1997
		ACCESSION NUMBER PARK-00834
		LOT QUANTIFICATION ITEM COUNT 1 STORAGE UNIT EA

CATALOG DATA

COLLECTION SITE 5 KM SOUTHWEST OF KIVIDLO	PARK PARK T. 11N. R. 25W. Sec. 41.	TOWNSHIP/RANGE/SECTION	COUNTY KLAMATH	STATE AK
WATERBODY/DRAINAGE UNNAMED CREEK	UTM Z/E/N 14/367834/3477467	LAT.	LONG.	ELEVATION
HABITAT/POSITIONAL ENVIRONMENT BEACH SURFACE FIND	FORMATION/PERIOD UNKNOWN	DIMENSIONS/WEIGHT L 100 CM		DEPTH
COLLECTOR HARRIS, BRYAN	COLLECTION NO. RH-97-652	COLLECTION DATE 08/05/1997	MAINTENANCE CYCLE 5.0/1998	CONDITION INC/FR
IDENTIFIED BY AND DATE HARRIS, BRYAN 08/05/1997	TYPE N	VALUE AT ACQUISITION, BASIS \$50	CURRENT VALUE, DATE, BASIS 10/01/1997 CATALOGER	PHOTO NUMBER 2289/24
CATALOGER AND DATE DAVIS, ARNOLD 10/01/1997	EMINENT FIGURE ASSOCIATION OTHER NUMBERS			

RESTRICTION	REPRODUCTION	PUBLICATION CITATION	PRESERVATION TREATMENT	CATALOG FOLDER	SIGNIFICANCE
N	N	N	N	N	N

U.S. DEPARTMENT OF THE INTERIOR **MUSEUM CATALOG RECORD - NATURAL HISTORY** NATIONAL PARK SERVICE
FORM 10-254B
REV. 7/84

Figure 3.10. Paleontology Catalog Record (Sample)

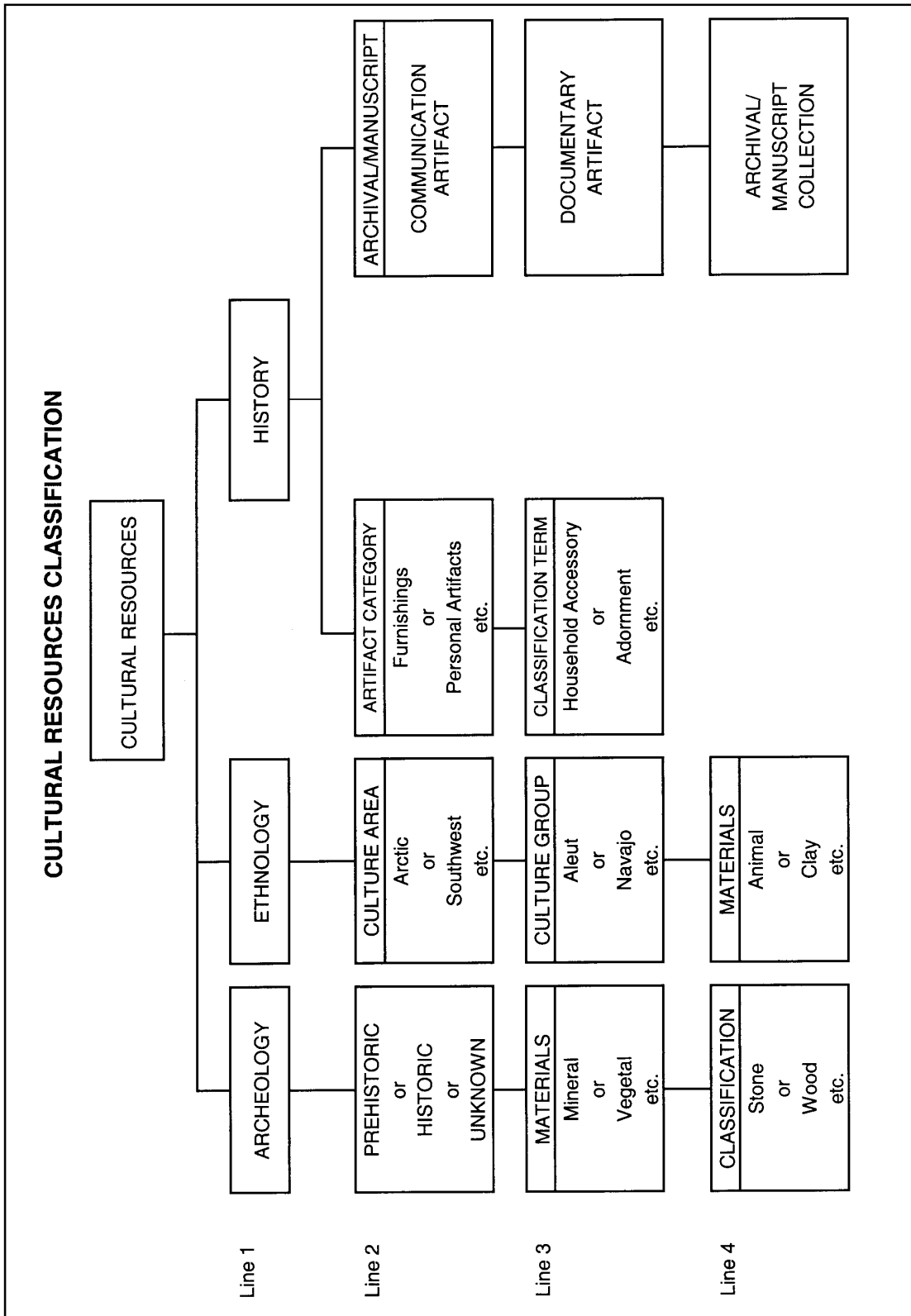

Figure 3.11. Cultural Resources Classification

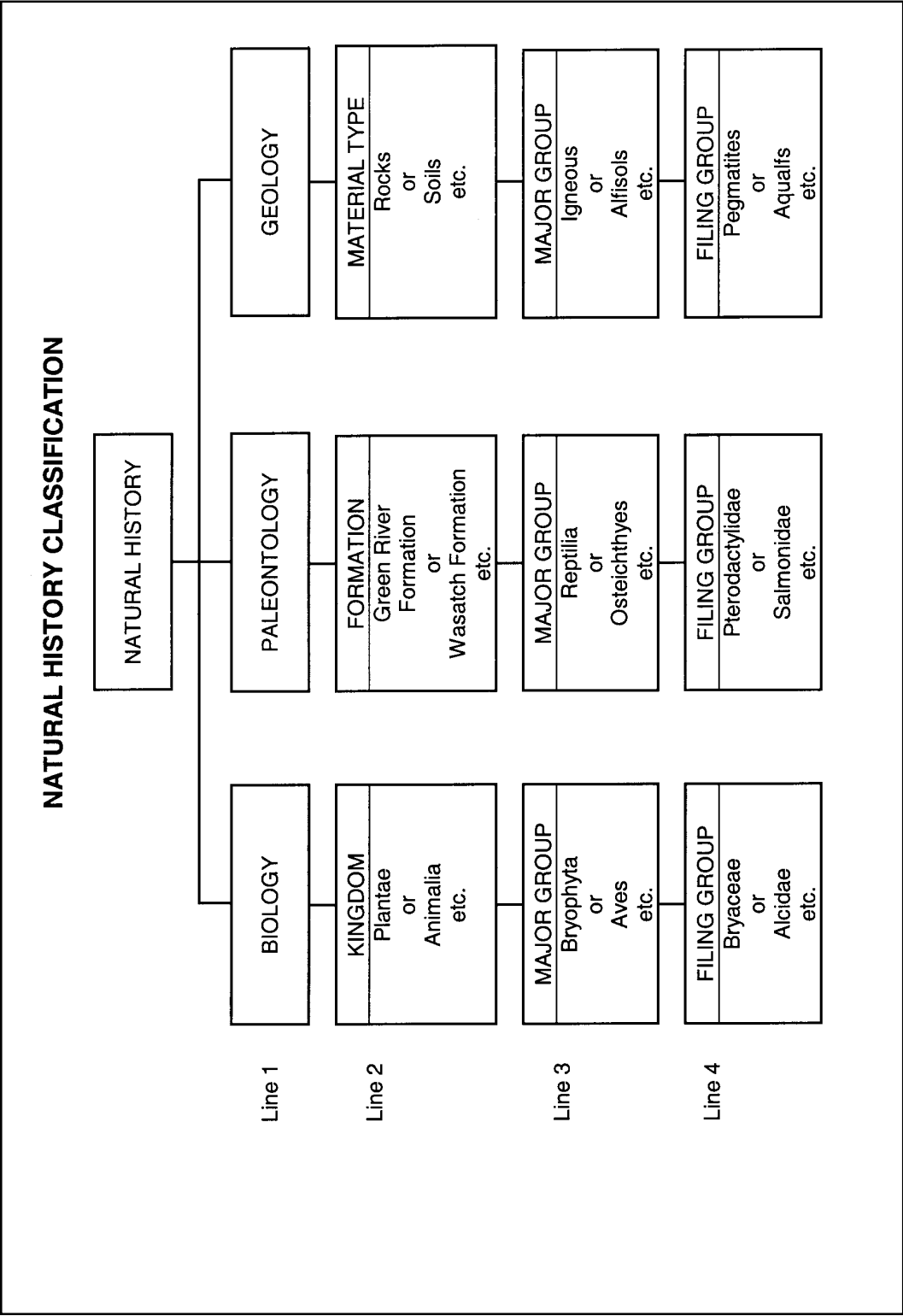

Figure 3.12. Natural History Classification

UNITED STATES
DEPARTMENT OF THE INTERIOR
National Park Service - Park Acronym
BUREAU OR OFFICE

RECEIPT FOR PROPERTY

NUMBER		DESCRIPTION (INCLUDE SERIAL NUMBERS, MODEL, ETC.)	QUANTITY	UNIT OF ISSUE	COST
ITEM	PROPERTY				
1		1 zip disk that contains the following two			
2		directories with FY99 tag files:			
3		PARK.ZIP contains PARKCR99.DBF (567-980)			
4		PARKNH.ZIP contains PARKNH99.DBF (362-456)			
5					
6					
7					
8					
9					
10					
11					
12					
13					
14					
15					
16					
17					
18					
19					
20					

Issued By: (Name and Title)		Date Issued:	
Name & Title of Person Issuing the Data		Date the Data Are Sent	
It is understood that I am personally responsible for the property listed hereon and that if any of the property is lost, stolen, damaged or destroyed through my simple or ordinary neglect or negligence or gross negligence I can be held financially liable as determined by a Board of Survey.			
Received By: (Name and Title)		Signature and Date:	

RETURN ORIGINAL TO EMPLOYEE UPON TURN-IN OF PROPERTY

Figure 3.13. Receipt for Property, DI-105 (Sample for National Catalog Submission)

Chapter 4: Inventory and Other Special Instructions

Page

Section I. Annual Inventory of Museum Property	4:1
A. Overview	4:1
What is the annual inventory?	4:1
What is the purpose of the inventory?	4:2
Who conducts the inventory?	4:2
How often do I conduct the inventory?	4:2
What is the Automated Inventory Program (AIP)?	4:2
What inventory reports does the AIP produce?	4:2
Will running the AIP change any of my catalog or accession data?	4:3
What is controlled property?	4:3
What is a random sample?	4:3
Why does the random sample inventory include controlled property?	4:4
What are the steps in completing the inventory?	4:4
Do I need to complete the inventory in any special order?	4:4
B. Conducting the Inventory	4:4
What does the AIP do?	4:4
What catalog and accession data does the program extract?	4:5
What if my park has objects that are cataloged but not yet entered into ANCS+?	4:5
What must I do for the inventory?	4:5
Must I inventory objects that are on outgoing loan?	4:6
What if my park manages more than one collection?	4:6
What if there are uncataloged objects in the museum collection?	4:6
What if some accessions have both cataloged and uncataloged objects?	4:6
What do I do if deaccessioned objects appear in the inventory?	4:6
Do I have to complete all the fields on the inventory?	4:6
Do I have to complete the inventory on the computer?	4:6
C. Completing the Random Sample and Controlled Property Inventories	4:7
How do I complete the random sample and controlled property inventories?	4:7
What are the data fields for the random sample and controlled property inventories?	4:7
Column 1 - Location	4:7
Column 2 - Catalog Number	4:7
Column 3 - Number in Use	4:7
Column 4 - Controlled Property	4:7
Column 5 - Object Found	4:7
Column 6 - Record Found	4:7
Column 7 - Location (Blue)	4:7
Column 8 - Location (ANCS+)	4:8
Column 9 - Other Data OK	4:8
Column 10 - Damaged	4:8
Column 11 - Object/Specimen Name	4:8
Column 12 - Remarks/Condition	4:8
D. Accessions Inventory	4:8
When do I need to conduct an accessions inventory?	4:8
Is the accessions inventory a random sample inventory?	4:8
Where do I find the accession documentation that I'll need for the inventory?	4:8
What if an accession on the inventory is fully cataloged?	4:8
What if an accession has both cataloged and uncataloged objects?	4:8
How do I conduct an inventory if the accession information is not specific?	4:9
How do I conduct an inventory of extremely large accessions?	4:9

E. Completing the Accessions Inventory	4:9
How do I complete the accessions inventory?	4:9
What are the data fields for the accessions inventory?	4:9
Column 1 - Location.....	4:9
Column 2 - Accession Number	4:9
Column 3 - Number in Use	4:9
Column 4 - Record Found	4:9
Column 5 – Catalog Status.....	4:10
Column 6 - Object Found.....	4:10
Column 7 - Damaged.....	4:10
Column 8 - Remarks/Condition.....	4:10
F. Submitting the Inventory	4:10
Who signs the inventory reports?	4:10
What happens to the inventory after signature?	4:10
Do I keep a copy of the inventory at the park?	4:10
G. Inventory Deficiencies and Property Irregularities	4:11
What are inventory deficiencies	4:11
What happens if there are inventory deficiencies?	4:11
What are property irregularities?	4:11
What happens if the inventory uncovers property irregularities?	4:11
Who investigates property irregularities?.....	4:12
H. Spot-Check Inventories and Audits	4:12
Who conducts a spot-check inventory?	4:12
What is a spot-check inventory?	4:12
What happens if a spot-check uncovers deficiencies?	4:12
Who conducts a museum property audit?	4:12
What happens to audit reports?	4:12
Section II. Documenting Object Location	4:12
A. Overview	4:12
Why is it important to document location?	4:12
Who is responsible for documenting object location?	4:12
B. Documenting Current Location	4:13
Where do I document current location?	4:13
Why is it important to be consistent in entering location?.....	4:13
What is a location file?	4:13
C. Documenting Location Changes	4:13
How do I document location changes?	4:13
How do I document temporary location changes?	4:14
Section III. Reporting Loss of Museum Objects	4:14
A. Overview	4:14
Who is responsible for reporting the loss of museum objects?	4:14
What is the definition of “loss”?.....	4:14
Where can I learn about prevention of loss?	4:15
Where can I find the procedures for investigating a loss?.....	4:15

B. Discovering Loss	4:15
Who usually discovers a loss?.....	4:15
What should I do first upon discovery of a loss?	4:15
When should I report a loss to a law enforcement officer?.....	4:15
C. Reporting Loss	4:16
How do I report a loss?	4:16
How do I document a loss?	4:16
What if the object is found?	4:16
What if the object is not found?	4:16
How do I report stolen museum collections to outside agencies?.....	4:16
Section IV. Reproductions, Living History Items, Exhibition Aids, and Outdoor Exhibits	4:19
A. Reproductions	4:19
Why are reproductions used in park exhibits?.....	4:19
What kinds of reproductions does the NPS use?	4:19
How are reproductions different from objects in the museum collection?	4:19
Must I accession and catalog reproductions?	4:20
How do I document commercially produced reproductions?.....	4:20
How do I document reproductions created for exhibit installation?	4:20
How do I document reproductions of specific items in a park or other museum's collection?.....	4:20
How do I document natural history specimens acquired for exhibit?	4:20
Do I manage reproductions differently from museum collections?.....	4:21
May I deaccession reproductions at the end of their useful life?.....	4:21
B. Living History Items	4:21
Are living history items part of the museum collection?.....	4:21
How does the park document living history items?	4:21
C. Exhibition Aids	4:22
What's the difference between reproductions and exhibit aids?	4:22
Do I need to accession and catalog exhibit aids and props?	4:22
D. Outdoor Exhibits	4:22
Do I catalog objects in outdoor exhibits?	4:22
Do I catalog fixed outdoor monuments?.....	4:22
Section V. Consumptive Use of Museum Objects	4:23
A. Overview	4:23
What is consumptive use?.....	4:23
Where can I find NPS guidelines on consumptive use of museum objects?	4:23
B. Consumptive Use Approval	4:23
Who approves consumptive use?.....	4:23
When is consumptive use acceptable?	4:23
When is consumptive use not acceptable?	4:24
Are there types of materials for which the regional director won't grant permission for consumptive use?	4:24

Section VI. Following Regulations for Cataloging Natural History Specimens	4:24
A. Overview	4:24
Where can I find information on collection permits for natural history specimens?	4:24
How can I help collectors with 36 CFR 2.5 compliance?.....	4:25
Who is considered a collector?	4:25
B. Documenting Natural History Collections Collected under 36 CFR 2.5g	4:25
Who accesses natural history specimens collected under 36 CFR 2.5g?.....	4:25
Who catalogs specimens stored in the park or a NPS repository?	4:25
Who catalogs collections stored in a non-NPS repository?.....	4:25
What materials for documenting collections must I give to the collector?	4:26
Do I have to buy an additional copy of ANCS+ to give to the collector?	4:26
What fields on the catalog record must the collector complete?	4:26
May I release catalog numbers to the collector?	4:27
Who is responsible for cataloging the field records?	4:28
Who is responsible for monitoring the accuracy of the records?	4:28
What documentation must the collector submit to you?	4:28
Who prepares the NPS natural history labels and marks the specimens?	4:28
C. Natural History Collections on Loan to Non-NPS Repositories	4:29
When do I place a natural history collection on loan to a non-NPS repository?.....	4:29
Am I responsible for monitoring the loan?	4:29
Section VII. Buying Insurance for Borrowed Objects	4:29
A. Overview	4:29
Why do I need to insure museum objects that I borrow?	4:29
Do I need to insure items left at the park for identification?.....	4:29
Do I need to insure property of the United States Government?	4:29
What is a tort claim?	4:30
B. Buying Insurance	4:30
Can the NPS buy insurance?	4:30
Who pays for the insurance?	4:30
How do I use the lender's policy?	4:31
What is a waiver of subrogation?.....	4:31
What is a certificate of insurance?.....	4:31
How do I buy an insurance policy to cover the items I borrow?	4:31
C. Insurance Policies	4:31
What standard features must an insurance policy include?	4:31
Do I need to update an existing insurance policy?	4:34
Section VIII. Completing the Collections Management Report	4:34
A. Overview	4:34
What is the Collections Management Report?	4:34
What is the purpose of the CMR?.....	4:34
Who completes the CMR?	4:34
When is the CMR due?	4:34
How do I complete the CMR?.....	4:34
What's the relationship between the CMR and GRPA?	4:34

B. Reporting Center Collections	4:35
Does the CMR include the objects I have at NPS centers and non-NPS repositories, such as universities?	4:35
Who completes the CMR for the collections I have at NPS centers?	4:35
Who completes the CMR for collections I have at non-NPS repositories?	4:35
Do I need to combine the center and repository reports with my park report?	4:35
What do I do with the summary report for my park?	4:36
C. CMR Program	4:36
What does the CMR program do?	4:36
Will running the CMR program change any of my ANCS+ data?	4:36
What if I have different collections within my park?	4:36
What is the structure of the CMR?	4:36
How does the CMR program count cataloged objects?	4:37
D. Completing the CMR	4:37
What are the steps in completing the CMR?	4:37
How does ANCS+ create my CMR?	4:37
Why would I need to make adjustments to my CMR?	4:37
What do I do if I think the data in my CMR are incorrect?	4:38
What are the data fields in Section I of the CMR?	4:38
What are the fields in Section II.A of the CMR?	4:39
What are the fields in Section II.B of the CMR?	4:39
What are the fields in Section II.C of the CMR?	4:39
What are the fields in Section II.D of the CMR?	4:40
What are the fields in Section III of the CMR?	4:40
E. Submitting the CMR	4:41
Do I need to print my CMR?	4:41
Do I need to submit a paper copy of my CMR?	4:41
Does anyone need to review my CMR before I submit it?	4:41
Section IX. Determining the Monetary Value of Museum Objects	4:42
A. Overview	4:42
What kinds of value do museum collections have?	4:42
When would I want to assign a monetary value to museum objects?	4:42
What types of collections don't have a monetary value?	4:42
B. Monetary Values	4:43
What is fair market value?	4:43
What is replacement value?	4:43
Do all objects have a fair market and replacement value?	4:43
C. Assigning Monetary Value	4:43
What makes an object valuable?	4:43
How does a specialist determine monetary value?	4:44
Can I assign values to museum objects?	4:44
What should I do before assigning a value to an object?	4:44
How can I gain expertise in market values?	4:45
What types of specialists are available in the NPS?	4:45
Must the specialist come to the park to evaluate the objects?	4:45

D. Professional Appraisals	4:45
What does a professional appraiser do?	4:45
When do I need to get a professional appraisal?	4:46
What should I look for in an appraiser?	4:46
How do I find appraisers?	4:46
What is the American Society of Appraisers?	4:47
How much does an appraisal cost?	4:47
Should I do a scope of work for the appraiser?	4:47
What must I do to prepare for the appraiser's visit?	4:47
What does an appraisal report include?	4:48
Can I request changes in an appraisal report?	4:48
Do I need to get more than one appraisal?	4:48
E. Re-Appraising Objects	4:49
How often should I re-appraise the objects in my collection?	4:49
How long is a professional appraisal valid?	4:49
F. Documenting Appraisal Information	4:49
Where do I document appraisal information on the catalog record?	4:49
Where should I keep appraisal reports and other written documentation on monetary value?	4:49
G. Appraisals and Tax Deductions	4:49
Can I appraise objects for tax deduction purposes?	4:49
Can I refer a donor to an appraiser?	4:49
What do I need to know about the IRS and donations to my museum collections?	4:50
Section X. List of Figures	4:50

BASIC REQUIREMENTS

Annual Inventory

Conduct an annual inventory of museum property using the Automated Inventory Program (AIP) in ANCS+. There are three parts to the inventory:

- 100% inventory of all controlled museum property
- random sample inventory of all cataloged museum property
- random sample inventory of all accessions, if you have accessions with uncataloged objects

The regional director sends museum property inventory certifications to the Associate Director, Cultural Resource Stewardship and Partnerships, Attention: Chief Curator, by September 30 each year.

Reporting Lost Objects

Report losses of museum objects to a park law enforcement officer as soon as possible after discovery.

Complete a Report of Survey (Form DI-103) for objects that you can't find within thirty days.

36 CFR 2.5 Regulations for Natural History Specimens

Ensure that natural history specimens that are retained in museum collections are cataloged in ANCS+. Place collections stored outside the park on loan.

Collections Management Report (CMR)

Each fiscal year, complete the CMR using ANCS+, and submit it electronically to the Museum Management Program by November 1.

CHAPTER 4: INVENTORY AND OTHER SPECIAL INSTRUCTIONS

Overview

This chapter outlines a variety of procedures that will help you manage museum collections. The chapter is divided into the following sections:

- Section I. Annual Inventory of Museum Property
- Section II. Documenting Object Location
- Section III. Reporting Loss of Museum Objects
- Section IV. Reproductions, Living History Items, Exhibition Aids, and Outdoor Exhibits
- Section V. Consumptive Use of Museum Objects
- Section VI. Following Regulations for Cataloging Natural History Specimens
- Section VII. Buying Insurance for Borrowed Objects
- Section VIII. Completing the Collections Management Report
- Section IX. Determining the Value of Museum Objects

Section I. Annual Inventory of Museum Property

A. Overview

1. *What is the annual inventory?*

The annual museum collection inventory consists of a:

- 100% inventory of all controlled museum property
- random sample inventory of all cataloged museum property (including controlled property)
- random sample inventory of accessions if any accessions have uncataloged museum property

Note: You don't have to do an accessions inventory if the only uncataloged objects are from accessions that you have received within the last year.

You must accession all uncataloged objects before conducting the inventory.

You must complete a 100% inventory instead of the random sample if your park has fewer than 250 catalog records.

You must complete a 100% inventory of accessions if:

- your park has fewer than 250 accessions
- some of those accessions have uncataloged objects that were acquired before the last inventory

2. *What is the purpose of the inventory?*

During the inventory, you will check the physical location, condition, and documentation for objects in the collection. The annual inventory allows you to identify object-specific and systematic accountability and collections management problems.

3. *Who conducts the inventory?*

The superintendent is responsible for insuring that park staff conduct the inventory. The superintendent delegates the authority to conduct inventories of the museum collection to the custodial officer. The custodial officer is usually the staff person responsible for the museum collection. Refer to Chapter 1 in this handbook and *Personal Property Management Handbook No. 44* for the definition of custodial officer.

The superintendent appoints a team of at least two individuals to complete the annual physical inventory:

- the custodial officer for museum property or a person designated by the custodial officer to provide expertise in verifying descriptions and access to the collections
- an impartial reviewer who doesn't have direct responsibility for the museum collection

4. *How often do I conduct the inventory?*

You must complete the inventory annually by the end of the fiscal year. The regional director should set up a regular schedule for parks in the region to complete the inventory. If you don't receive a regional call to do the inventory, the superintendent can set the date.

5. *What is the Automated Inventory Program (AIP)?*

The Automated Inventory Program (AIP) partially automates the inventory process and prints the inventory reports.

You must use the AIP to do the annual inventory. Refer to the ANCS+ User Manual, Appendix F, Automated Inventory Program, for instructions on running the AIP.

6. *What inventory reports does the AIP produce?*

The AIP will produce the following reports as part of the inventory process:

- Inventory of Museum Property (Random Sample), Form 10-349 (Figures 4.1a – 4.1d)
- Inventory of Museum Property (Controlled), Form 10-349 (Figures 4.2a – 4.2d)
- Inventory of Museum Property (Accessions), Form 10-349 (Figures 4.3a – 4.3d), if appropriate

7. *Will running the AIP change any of my catalog or accession data?*

No. Running the AIP doesn't change ANCS+ catalog or accession data. The AIP extracts information from existing records, but doesn't modify them. You can't change your records from the AIP. You must go to the appropriate database to make changes to your data. If during the inventory you note that there are incorrect data on the catalog record, remember to update the catalog record.

8. *What is controlled property?*

Controlled museum property includes all:

- objects valued at \$1,000 or more
- firearms
- incoming loans

NPS repositories do not treat incoming loans from parks as controlled property.

You should also designate the following as controlled:

- objects that are especially vulnerable to theft, loss or damage (the park must assess the risk)
- natural history specimens with high scientific value, such as type or voucher specimens

You must do a 100% inventory of controlled property.

You must accession and catalog all controlled property. Enter a Y in the Controlled Property field on the catalog record to indicate controlled property.

9. *What is a random sample?*

The random sample used in the inventory serves as an indicator of accountability for the entire collection. If you have accounted for all the objects in the sample inventory, it is assumed that you can account for all objects in the collection.

The AIP creates a valid random sample by randomly selecting catalog and accession numbers from a statistically valid sample size. A random sample is used to complete the Inventory of Museum Property (Random Sample) and Inventory of Museum Property (Accessions).

The sample size and percentage of collection to be sampled varies depending on the size of the collection. The larger the collection, the smaller the percentage of the collection that you must sample. For example, a collection with 253 records will sample 121 records. A collection with 150,000 or more records will sample 203 records. You will never sample more than 203 records.

10. *Why does the random sample inventory include controlled property?*

Controlled property appears in the random sample inventory even though you must conduct a separate, 100% inventory of controlled property. This is because the entire set of sequential numbers is needed to run a statistically valid sample. The AIP randomly selects catalog numbers from the sequential catalog numbers for the entire cataloged collection.

Note: You don't need to inventory controlled property twice. Copy the data for the controlled property that appears in the random sample inventory into the controlled property inventory or vice versa.

11. *What are the steps in completing the inventory?*

To complete the inventory:

- Generate the numbers and data for the inventory using the AIP.
- Print the inventory forms from the AIP.
- Complete the inventory by:
 - finding the objects and records
 - answering the questions on the inventory form
 - totaling the responses
 - completing the summary sheet
- *Optional:* Enter the inventory responses directly into the AIP and print the forms and the summary sheet.
- Have the custodial officer and staff conducting the inventory sign the forms.
- Have the superintendent review and sign the inventory.
- Update the catalog records as needed.

Note: You must repeat the process for all three parts of the inventory.

12. *Do I need to complete the inventory in any special order?*

No. Once you generate the numbers for the inventory, you can complete the inventory in any order you choose.

B. Conducting the Inventory

1. *What does the AIP do?*

The AIP will:

- determine the sample size from the highest catalog number and highest accession number you enter
- randomly select catalog and accession numbers for you to inventory (**Note:** You must generate the numbers in the presence of the custodial officer and all those who sign the inventory form, except the superintendent.)
- pull all controlled property for the controlled property inventory and allow you to enter non-electronic controlled property
- extract selected data from ANCS+ catalog and accession records and index catalog records by location and by ascending numbers for each

location

- allow you to edit selected AIP fields on line
- print the inventory forms containing the randomly selected and controlled property numbers and ANCS+ information
- print the completed inventory forms with the data you have entered
- total the inventory entries and print a summary sheet

2. *What catalog and accession data does the program extract?*

The AIP extracts the location, catalog number, controlled property status, and object/specimen name for all catalog records it pulls from ANCS+. This information appears on the screen and prints on the Form 10-349.

The AIP extracts the accession number and the data in the Catalog Status field for all accession records it pulls from ANCS+. This information appears on the screen and prints on the Form 10-349.

3. *What if my park has objects that are cataloged but not yet entered into ANCS+?*

If a catalog number isn't in ANCS+, the program can't extract data from the record. You will have to enter this information from the paper record. The only fields on the screen that will have entries are the catalog number field and the Rediscovery Status field. "Not in Rediscovery" will appear in the Rediscovery Status field.

Note: For controlled property only, you can add non-electronic catalog numbers to the inventory.

4. *What must I do for the inventory?*

To generate random catalog and accession numbers you must:

- look up the highest catalog number in use and enter it in the AIP
- look up the highest accession number in use and enter it in the AIP

For cataloged objects you must enter the following:

- presence or absence of the museum object
- presence or absence of the catalog record
- accuracy of location information and other data on the catalog record
- any change in the object condition

For accessions, you must enter the following:

- presence or absence of the accession record (including documents in the accession file)
- catalog or deaccession status of the objects in the accessions

If the accession includes uncataloged objects, you must enter the following:

- presence or absence of the objects in the accession as determined by

spot-check

- any change in the overall condition of the objects in the accession as determined by spot-check

5. *Must I inventory objects that are on outgoing loan?*

Yes. You must inventory objects on outgoing loan if their catalog numbers appear on the inventory. Verify the presence and condition of those objects either personally, by telephone, or in writing. Make a note in the Remarks/Condition column on the inventory form.

Note: You don't need to verify an object on outgoing loan if you have checked it within the last year. For example, if you renewed the loan within the last year, you don't need to verify the object.

You don't need to verify the presence and condition of objects on outgoing loan to a NPS repository. Note the acronym of the NPS repository in the Remarks/Condition column on the inventory form. NPS repositories must complete an annual inventory for park collections at the repository.

You must include collections on loan to a non-NPS repository as part of the park's inventory. You must verify the presence and condition of objects on outgoing loan to a non-NPS repository if they appear on the inventory.

6. *What if my park manages more than one collection?*

If you have units with more than one series of accession and catalog numbers, complete a separate inventory for each unit.

7. *What if there are uncataloged objects in the museum collection?*

You must inventory uncataloged objects using the random sample of accessions until you can catalog the objects. You don't have to inventory uncataloged objects from accessions that you've received since the last annual inventory.

8. *What if some accessions have both cataloged and uncataloged objects?*

You will inventory the cataloged objects as part of the random sample and controlled property inventories. You will inventory the uncataloged objects as part of the accessions inventory.

9. *What do I do if deaccessioned objects appear in the inventory?*

You have accounted for the object if it has been deaccessioned. Although you no longer have the object, the catalog number and record for a deaccessioned object remain in the database. Answer the inventory questions about the catalog record, and note in the Remarks/Condition field that the object is deaccessioned.

10. *Do I have to complete all the fields on the inventory?*

No. You may not always have information to enter in the Remarks/Condition field. In some cases, the instructions say to leave fields blank. For example, if a catalog number is not in use, leave the fields blank.

11. *Do I have to complete the inventory on the computer?*

No. You must generate the numbers and print the inventory forms from ANCS+. You can complete the forms by hand or on the computer.

<i>If you...</i>	<i>Then...</i>
enter the inventory data on the computer,	the AIP will total the answers and complete the summary sheet.
complete the forms by hand,	you'll have to total the answers, print a blank summary sheet, and complete the summary sheet manually.

C. Completing the Random Sample and Controlled Property Inventories

1. *How do I complete the random sample and controlled property inventories?*

You must complete the inventories using the Automated Inventory Program in ANCS+. Refer to Appendix F: Automated Inventory Program in the *ANCS+ User Manual* for specific information on completing the inventory fields.

2. *What are the data fields for the random sample and controlled property inventories?*

The data fields for the random sample and controlled property inventories are identical. For most fields, use a yes or no entry that is abbreviated “Y” or “N”. A few fields, such as the Remarks/Condition field, allow you to enter text.

Column 1 – Location

This is the physical location of the object.

Column 2 – Catalog Number

This is the object’s catalog number.

Column 3 – Number In Use

This column shows whether the catalog number is in use.

Note: If the catalog number isn’t in use, leave the other fields blank.

Column 4 – Controlled Property

This column shows whether the object is controlled property. Refer to question A.8 in this section of the chapter for a definition of controlled property.

Note: Deaccessioned objects should not be controlled property.

Column 5 – Object Found

This column shows whether you found the object or group of objects corresponding to the catalog number.

Note: Enter a Y (yes) for deaccessioned objects since you have accounted for these objects.

Column 6 – Record Found

This column shows whether you found the catalog record for the object.

Column 7 – Location (Blue)

This column shows whether the location on the blue paper copy of the catalog record is correct.

Note: Leave this field blank if you’re using the electronic record in place of the blue paper record.

Column 8 – Location (ANCS+)

This column shows whether the location on the electronic copy of the catalog record is correct.

Note: Leave this field blank if you’re using the blue paper record in place of the electronic record.

Column 9 – Other Data OK

This column shows whether the information on the museum catalog record is complete and accurate.

Column 10 – Damaged

This column shows whether you observe any damage or deterioration to the object.

Column 11 – Object/Specimen Name

This is the name of the object.

Column 12 – Remarks/Condition

Enter any remarks or notes on condition in this column.

D. Accessions Inventory

1. *When do I need to conduct an accessions inventory?*

<i>If...</i>	<i>Then...</i>
the entire collection is cataloged,	don’t complete an accessions inventory.
the only uncataloged objects in the collection are from accessions that you received within the last year,	don’t complete an accessions inventory.
you have uncataloged collections from accessions you received before the last inventory,	you must complete an accessions inventory.

2. *Is the accessions inventory a random sample inventory?*

Yes. When you enter the highest accession number in use, the AIP generates a random sample of accession numbers. If you have fewer than 250 accessions, the AIP will list all the accession numbers.

The accessions inventory is a substandard level of accountability because the property is not cataloged.

3. *Where do I find the accession documentation that I’ll need for the inventory?*

Use the accession book, the ANCS+ accession record, and the accession folder to find accession documentation. Also refer to previous annual inventories for these data.

4. *What if an accession on the inventory is fully cataloged?*

Fully cataloged accessions appear in the random sample accessions inventory. This is because the program needs all your accession numbers to run a statistically valid sample. You must verify the accession documentation for fully cataloged accessions, but you don’t need to check the objects.

5. *What if an accession has both cataloged and uncataloged objects?*

Inventory only the uncataloged objects. Don’t inventory the cataloged objects as part of the accessions inventory.

6. *How do I conduct an inventory if the accession information is not specific?*

You can only conduct the accessions inventory to the level of detail given in the accession record. If the accession information doesn't include a list with the number and type of objects, make a list at the time of inventory. Date the list, and file it in the accession folder. It will allow future inventories to be more precise.

<i>If the accession records shows...</i>	<i>Then you would check for...</i>
2 dinner forks	2 dinner forks
5 boxes of archeological material	5 boxes that have an unspecified amount of archeological material
types of objects, such as military gear or household goods	an unspecified amount of military gear or household goods

7. *How do I conduct an inventory of extremely large accessions?*

Do a spot-check of the objects in the accession to see if the objects match the accession information. Use the most detailed object list available. You can spot-check a large accession by doing a random sample of the objects in the accession. For example, you could check every tenth object in the list.

E. Completing the Accessions Inventory

1. *How do I complete the accessions inventory?*

You must complete the accessions inventory using the Automated Inventory Program in ANCS+. Refer to Appendix F: Automated Inventory Program in the *ANCS+ User Manual* for specific information on completing the inventory fields.

2. *What are the data fields for the accessions inventory?*

The data fields for the accessions inventory include:

Column 1 – Location

This is the physical location of the accession. This entry is optional.

Column 2 – Accession Number

This is the number of the accession.

Column 3 – Number in Use

This column shows whether the accession number is in use.

Note: If the accession number isn't in use, leave the other fields blank.

Column 4 – Record Found

This column shows whether you found the accession records for the accession.

Accession records include an:

- entry in the accession book, *and*
- accession folder with the required documents from Chapter 2: Accessioning in this handbook

Column 5 – Catalog Status

This column shows whether the accession is:

- not cataloged
- partially cataloged
- fully cataloged
- deaccessioned

Note: If the accession is fully cataloged, leave the other fields blank.

Column 6 – Object Found

This column shows whether you found the object or group of objects corresponding to the accession number.

Report all missing objects in the Remarks/Condition field.

Column 7 – Damaged

This column shows whether you observe any damage or deterioration to the objects in the accession.

Column 8 – Remarks/Condition

Enter any remarks or notes on condition in this column.

F. Submitting the Inventory

1. *Who signs the inventory reports?*

The staff members who conducted the inventory sign and date the inventory after reviewing and verifying it.

The superintendent and the custodial officer must sign and date the certification statements on the cover sheet of Form 10-349. There is a separate cover sheet for each part of the inventory (random sample, controlled property, and accessions).

2. *What happens to the inventory after signature?*

The superintendent must send a copy of the inventory to the regional director. Director's Order #24: NPS Museum Collections Management, states that the regional director:

- certifies that all parks have completed the annual inventory
- sends the certification to the Associate Director, Cultural Resource Stewardship and Partnerships, Attention: Chief Curator, no later than September 30 each fiscal year.

Note: The superintendent must submit a copy of the full inventory for museum property to the regional director. See Director's Order #24: NPS Museum Collections Management.

3. *Do I keep a copy of the inventory at the park?*

The superintendent must keep a copy of the inventory for three years. It is recommended that you keep a copy of the inventory with the museum records for at least five years.

If you have the space, you may want to keep copies of past inventories indefinitely. Past inventories can be very useful references when an object is missing. You may be able to use the inventory to prove when the object was last seen in the collection.

If the inventory has uncovered problems, such as large numbers of losses, keep a complete copy until you have corrected the problems.

G. Inventory Deficiencies and Property Irregularities

1. *What are inventory deficiencies?*

Inventory deficiencies are problems that the inventory uncovers, such as:

 - the loss of an object
 - incorrect locations
 - damage to an object
2. *What happens if there are inventory deficiencies?*

The superintendent is responsible for the accuracy of the park inventory. He/she must correct any problems that the inventory uncovers and reduce the risk of future problems. The superintendent must request that a Board of Survey investigate the loss or damage of museum property. The regional director is the reviewing authority for the Board of Survey.

The park may want to consult the regional/SO curator for advice on correcting problems and reducing the risk of future loss and damage.

Refer to the *Personal Property Management Handbook No. 44* for information on Board of Survey procedures.
3. *What are property irregularities?*

Property irregularities are losses of property that point to serious accountability and management problems. They include:

 - evidence of fraud or falsifying records
 - large numbers of damaged or lost objects
 - losses of a suspicious nature

Property irregularities are most likely to come to light during the annual inventory.

Refer to the Interior Property Management Regulations (IPMR 420 DM 114-60.811) and the *Personal Property Management Handbook No. 44* (Section 8.24) for information on property irregularities.
4. *What happens if the inventory uncovers property irregularities?*

Property irregularities require an additional investigation beyond a Board of Survey. The Board of Survey reports evidence of property irregularities to the superintendent. The regional director reviews the board's findings and directs the superintendent to take immediate corrective action. This may include a 100% inventory of the collection.

The regional director must send a description of any property irregularities and corrective actions to the Associate Director, Cultural Resource Stewardship and Partnerships, Attention: Chief Curator.

5. *Who investigates property irregularities?* After reviewing the findings of the Board of Survey, the regional director or Director may call for an investigation by:
- field or Washington office staff, *or*
 - the Department of the Interior Office of the Inspector General (OIG)
-

H. Spot-Check Inventories and Audits

1. *Who conducts a spot-check inventory?* The regional director and the Associate Director, Cultural Resources, can request spot-check inventories. They may periodically request their staff to do sample spot-checks of park museum collections and records.
2. *What is a spot-check inventory?* A spot-check inventory involves two parts. The person conducting the spot-check will choose a small sample of objects and unrelated catalog (or accession) records. You must then:
- produce the corresponding catalog (or accession) records for the objects
 - locate the corresponding objects for the records
- A spot-check inventory may also involve a spot-check of the most recent annual inventory for accuracy.
3. *What happens if a spot-check uncovers deficiencies?* The staff conducting the spot-check will report any serious deficiencies or property irregularities to the regional director. He or she will direct the superintendent to take corrective action.
4. *Who conducts a museum property audit?* If requested by the NPS, the OIG will perform audits of park museum collections. The Inspector General may also call for an audit whenever he/she determines the need for one.
5. *What happens to audit reports?* The OIG sends audit reports to the Director. The Director forwards these reports to the appropriate regional director, who must review the audit and submit a program for corrective action, if necessary. The Inspector General tracks the program until the NPS accomplishes any necessary corrective action.

Section II. Documenting Object Location

A. Overview

1. *Why is it important to document location?* Documenting the physical location of an object is an important part of cataloging. You need to know the location of objects in the collection to be able to access and care for them.
2. *Who is responsible for documenting object location?* The staff person responsible for the museum collection must maintain current physical location information for all objects in the collection.

B. Documenting Current Location

1. *Where do I document current location?*

Document current location on the catalog record. Enter the current location in the Object Location field in ANCS+. Enter changes in location for manual, paper records in pencil in the Object Location field.

2. *Why is it important to be consistent in entering location?*

Entering location information consistently in ANCS+ allows you to quickly find the information and create reports on object location. The location should be specific, so that you can easily find the object. Refer to the *ANCS+ User Manual* for instructions on completing the Object Location field.

Note: Using letters and numbers to identify location areas can help you keep consistent location data. You may want to keep a map of each structure that has museum collections. Identify each room or area by a letter and/or number, including exhibit cases. In storage areas, you may want to keep a map of each storage unit, such as cabinets and cases. Identify each unit by a letter and/or number. Post the map in the storage area. Include location maps as part of your site-specific cataloging guidelines.

3. *What is a location file?*

A location file gives catalog data for objects at a particular location within the park. This electronic or manual file may consist of:

- copies of catalog records arranged in numerical order by catalog number
- an ANCS+ or computer generated report of catalog numbers (and other pertinent data) for each location (index the report on object location and catalog number)

A location file can be especially useful for parks with:

- furnished structures (the file provides a record of furnishings by room)
- large collections housed in several structures (the file shows the objects in each location)
- exhibits with multiple exhibit cases

Use of a location file is optional.

C. Documenting Location Changes

1. *How do I document location changes?*

You must note any changes in object location. Develop a system for documenting location changes as they occur. Update the object location field in ANCS+ and location files as needed.

Note: ANCS+ will track changes in location. You can also do mass location updates in ANCS+. For tracking location changes, refer to the instructions on saving a record in Chapter 2 of the *ANCS+ User Manual*.

Refer to Section X of Chapter 3 in the *ANCS+ User Manual* for information on the Location supplemental record and mass location updates.

2. *How do I document temporary location changes?*

When you temporarily remove an object, you can mark the location with an Object Temporary Removal Slip, Form 10-97 (Figure 4.4). It gives you a visual reminder of an object's location and removal. It's especially useful in exhibits and furnished rooms as a reminder to staff. Use of this form is optional. The form includes:

- catalog number
- permanent location
- purpose for removal
- temporary location
- who removed the object
- the date the object was removed

You can print Form 10-97 from ANCS+.

Use a separation sheet for archival and manuscript collections. See Appendix D in this handbook for an example.

Section III. Reporting Loss of Museum Objects

A. Overview

1. *Who is responsible for reporting the loss of museum objects?*

The staff person who is responsible for the museum collection must:

- report losses to a park law enforcement officer and the accountable officer as soon as possible
- document the loss
- document the circumstances surrounding the loss

2. *What is the definition of "loss"?*

The term "loss" means traumatic and total loss:

- theft
- destruction
- disappearance

It doesn't refer to losses of integrity (breakage, fading, infestation, or other deterioration) or the deliberate deaccession of objects.

3. *Where can I learn about prevention of loss?* Refer to *MH-I*, Chapter 9, Security and Fire Protection, and Chapter 10, Emergency Planning.
4. *Where can I find the procedures for investigating a loss?* Procedures for investigating a loss follow:
- Director’s Order #9: Law Enforcement Program and the Law Enforcement Reference Manual (RM-9)
 - *Personal Property Management Handbook No. 44*
 - Interior Personal Property Management Regulations (IPMR 410 DM 114-60)
- There may also be park-specific and regional procedures for investigating losses.

B. Discovering Loss

1. *Who usually discovers a loss?* Staff conducting the annual inventory most frequently discover losses. You may also receive loss reports from housekeepers, security personnel, or interpreters. These staff may notice something missing when they make their customary rounds.
2. *What should I do first upon discovery of a loss?* Search the area to see if the object has been misplaced in a nearby location. If you can’t locate the object:
- make a copy of the Museum Catalog Record (Form 10-254)
 - gather any additional information that might be useful, such as additional information in ANCS+ or the catalog folder
 - locate any available photographs or other images of the object
- Give this information, along with a verbal report of the loss, to a park law enforcement officer. At some parks, there is a designated law enforcement officer who is responsible for the museum collection.
3. *When should I report a loss to a law enforcement officer?* If you are unable to locate an object after a complete search, contact a law enforcement officer. This should be as soon as possible after discovery of the loss. A delay may jeopardize your ability to reclaim the object if it is later found. Provide the officer investigating the loss with all relevant museum records, including accession and catalog information.
- Conduct a search for the object with the law enforcement officer and, if possible, the person who reported the loss. Use a catalog record and photograph, if available, to aid in identification.

C. Reporting Loss

1. How do I report a loss?

If the search for the object is unsuccessful, the law enforcement officer must complete a Case Incident Record, Form 10-343, or equivalent. Be sure to get a copy as well as the case number.

Note: The case incident record should show that the missing object is museum property. Attach a copy of the catalog record and any other pertinent data from the catalog or accession folder to the report.

2. How do I document a loss?

Change the Object Status field on the catalog record to Missing. Enter the year that you discovered the loss in the Status Date field. Place copies of the case incident record and all other documentation relating to the loss in the appropriate accession folder.

3. What if the object is found?

Change the Object Status field from Missing to the appropriate entry, such as Storage or Exhibit. Note the disappearance and recovery of the object on the catalog record or in the accession folder. Assess and record the condition of the object upon its return.

4. What if the object is not found?

Start the process of deaccessioning the object if you can't find it within thirty days after reporting its loss. Complete a Report of Survey, Form DI-103 (Figure 4.5). A Board of Survey must review the DI-103. Refer to Chapter 6, Deaccessioning, in this handbook and the *Personal Property Management Handbook No. 44*.

5. How do I report stolen museum collections to outside agencies?

Notify NPS and local law enforcement authorities before contacting outside agencies.

The more widely you report a loss, the better chance of its recovery. In some jurisdictions, the local police will report crimes to the FBI and to Interpol. You may have to notify all other agencies and offices. Refer to the following list in the event of a theft or other criminal loss of museum objects.

Agency/Office

National Stolen Art File
Federal Bureau of Investigation
IT/GRCU Room 5096
935 Pennsylvania Ave, NW
Washington, D.C. 20535
Tel: 202 -324-6668

Web Address:

<www.fbi.gov/majcases/arttheft/art.htm>

Report all information through local FBI office.

Comments

- Investigates theft of cultural property valued over \$5,000 (fine art, gems, and coins over \$2,000) and when interstate commerce is suspected
- Stolen and recovered property listed on-line
- Art Theft Link: <www.saztv.com/page11.html>
 - includes a listing of databases of stolen art
 - lists information on stolen books, manuscripts, musical instruments, artifacts, fossils, and other materials
 - lists contact information for art detectives, security consultants, art loss register, and insurance

Agency/Office

INTERPOL

U.S. Department of Justice
INTERPOL
U.S. National Central Bureau
Washington, D.C. 20530

INTERPOL's home page:
<www.interpol.int/>

Cultural Property Program,
INTERPOL-USNCB
US. Department of Justice
Washington, D.C. 20530
Tel: 202- 616-6769
Fax: 202- 616-8400

INTERPOL's stolen cultural
property home page:
<[www.usdoj.gov/usncb/
culturehome.htm](http://www.usdoj.gov/usncb/culturehome.htm)>

American Philatelic Society

Stamp Theft Committee
P.O. Box 8000
State College, PA 16803
Tel: 814- 237-3803
Fax: 814- 237-6128

Web Address: <www.stamps.org>
for stamp theft:
<[www.stamps.org/aps/services/
defense.htm](http://www.stamps.org/aps/services/defense.htm)>

Art Dealers Association of America

575 Madison Ave
NY, NY 10022
Tel: 212- 940-8590
Fax: 212- 940-7013

Web Address:
<www.artdealers.org>

Comments

- fine art, gems, and coins thought to be transported internationally
- stolen and recovered property listed on-line
- publishes "Stolen Property Notice" monthly, and "Twelve Most Wanted" to 135 countries plus 15 addresses in the US

- stamps only
- published in *American Philatelist* monthly to 55,000 subscribers
- all recovery information requests are shared with police

- on-line search for catalogs published by members of the ADAA
- offers free subscriptions to ADAA Report, a newsletter publicizing current issues regarding art and museums
- publishes reports bimonthly for law enforcement agencies, dealers, and major museums (plus 1,000 addresses)
- fine art, gems and coins only
- stolen and recovered property listed on-line

Agency/Office

International Foundation for Art Research, Inc.

500 Fifth Avenue, Suite 1234
NY, NY 10110
Tel: 212- 301-7234
Fax: 212- 391-8794

Web Address: <www.ifar.org>

Local Newspaper

Society of American Archivists

527 S. Wells St., 5th Floor
Chicago, IL 60607-3922
Tel: 312- 922-0140
Fax: 312- 347-1452

Web Address:
<www.archivists.org>

Special Agent-In-Charge
U.S. Custom Service
P.O. Box 938
Church St. Station
NY, NY 10008
Hotline: 1-800-232-5378

Web Address:
<www.customs.treas.gov/>

Commanding Officer
NYC Police Department
Special Investigations Division:
Major Case Squad
1 Police Plaza
New York, NY 10038
212-374-3955

Art Loss Register

U.S. Office
20 East 46th Street, Suite 1402
New York, NY 10017
212-297-0941
Fax: 212-972-5091

Web Address:
<www.artloss.com>

Comments

- offers impartial authentication services and information regarding theft and other ethical issues
- publishes *IFAR Journal* quarterly, featuring information on art fraud, and art and cultural property law
- publishes “Stolen Art Alert” monthly, and “Art Theft Alert” on major thefts

- provides press releases and photographs

- provides information about stolen archival materials through the *American Archivist Journal* and its web site

- reports thefts from all states
- for exported art
- includes listings for other organizations
- information available through police organizations

- fine art, gems, and coins only
- stolen and recovered property listing indexed
- publishes reports bimonthly, for law enforcement agencies, dealers, and major museums
- New York City area only

- maintains database of stolen collectibles
- sells the database to museums and auction houses to prevent acquisitions of stolen property

Agency/Office	Comments
Market Alert Journal of Field Archaeology Boston University 675 Commonwealth Ave Boston, MA 022215 Tel: 617-353-2357 E-mail : jfa@bu.edu	<ul style="list-style-type: none"> • excavated archeological material with some documentation • stolen and recovered materials • publishes information quarterly in <i>Journal of Field Archaeology</i>
Object ID™ Council for the Prevention of Art Theft The Estate Office Stourhead Park Stourton, Warminster Wiltshire BA12 6QD UK Tel and Fax: +44.1747.841540 Web Address: <www.info@object-id.com>	Promotes crime prevention in the fields of art, antiques, antiquities, and architecture.

Section IV. Reproductions, Living History Items, Exhibition Aids, and Outdoor Exhibits

A. Reproductions

- | | |
|---|---|
| <p>1. <i>Why are reproductions used in park exhibits?</i></p> | <p>A park may acquire reproductions for exhibit for a variety of reasons:</p> <ul style="list-style-type: none"> • the park does not have the specific items needed for the exhibit • original or period pieces are not available • to protect original objects, such as replacing an original chair with a reproduction to protect the original |
| <p>2. <i>What kinds of reproductions does the NPS use?</i></p> | <p>Parks use several different types of reproductions in exhibits:</p> <ul style="list-style-type: none"> • commercially produced reproductions • reproductions created for a specific exhibit installation • reproductions of objects in the park or in another museum's collection <p>Refer to Chapters 4 and 5 in the <i>MH-III</i> for information on two-dimensional and three-dimensional reproductions.</p> |
| <p>3. <i>How are reproductions different from objects in the museum collection?</i></p> | <p>Although reproductions have monetary and interpretive value, they generally don't have the associative value that would make them important to the park museum collection. However, in certain cases, reproductions may be the only remaining evidence of the original. They may also be inherently valuable themselves, such as the Navajo rug reproductions at Hubbell Trading Post NHS.</p> |

4. *Must I accession and catalog reproductions?* Yes. To provide accountability, you must accession and catalog reproductions into the museum collection. Follow the instructions in Chapter 2 and Chapter 3 in this handbook. Refer to Section Y in Appendix D of this handbook for information on cataloging two-dimensional reproductions.
5. *How do I document commercially produced reproductions?* Clearly and permanently mark these items as reproductions. Write “reproduction” in an accessible, but not obtrusive, location on all commercially produced reproductions. Refer to Appendix J in this handbook for marking techniques.
- If the park purchased the items from a catalog, make copies of the pertinent pages of the catalog. Place the copies in the accession or catalog folder to give further information on the source and the object.
- Enter Reproduction in the Reproduction field in ANCS+. Enter “Reproduction acquired for purposes of exhibition” in the Description field in ANCS+.
6. *How do I document reproductions created for exhibit installation?* Some reproductions are created specifically for exhibit installation, such as furnishings for a general store. Clearly and permanently mark these items as reproductions. Write “reproduction” on the item in an accessible, but not obtrusive, location. Refer to Appendix J in this handbook for marking techniques. Place copies of the documentation about the production of these items, such as plans and specifications, in the accession or catalog folder.
- Enter Reproduction in the Reproduction field in ANCS+. Enter “Reproduction acquired for purposes of exhibition” in the Description field in ANCS+.
7. *How do I document reproductions of specific items in a park or other museum’s collection?* These items have been produced from original objects. They are replicas using the same materials and techniques as the original. Use the accession or catalog folder to file documentation about the current location of the original item and plans and specifications for the reproduction. Clearly and permanently mark these items as reproductions. Write “reproduction” on the item in an accessible, but not obtrusive, location. Refer to Appendix J in this handbook for marking techniques.
- Enter Reproduction in the Reproduction field in ANCS+. Enter “Reproduction of [catalog number of the original] acquired for purposes of exhibition” in the Description field in ANCS+.
8. *How do I document natural history specimens acquired for exhibit?* For exhibit purposes, the park may acquire natural history specimens from outside the park’s Scope of Collection Statement. For example, a commercial scientific company may supply a beaver from Michigan to a park in the Southwest. If the park purchased the specimens from a scientific catalog, make copies of the pertinent pages of the catalog. File the copies in the accession folder to show the source.
- Enter “Specimen acquired for purpose of exhibition” in the Description field of ANCS+.
- Note:** See Chapter 2 in this handbook for special requirements for acquiring threatened and endangered species. See Chapter 5 in this handbook for special requirements for loaning threatened and endangered species.

9. *Do I manage reproductions differently from museum collections?*

No. Manage reproductions as part of the museum collection, with one exception. Generally, reproductions receive routine approval for consumptive use. However, reproductions that are of high monetary value and/or importance to the collection, or those that replace badly deteriorated originals, should not be consumptively used.

Refer to Section V in this chapter for information on consumptive use.

10. *May I deaccession reproductions at the end of their useful life?*

Yes. Deaccession all cataloged reproductions by following the guidance in Chapter 6 in this handbook. You may determine the disposition of reproductions at the time of acquisition. This will assist staff in making a decision at the end of an object's useful life. You must fully note the recommended disposition in the accession folder at the time of acquisition. Consider the current market value when determining disposition.

Some reproductions, such as curtains and rugs, will wear out in time. If possible, save a small sample of the reproduction. Generally, worn out reproductions will be destroyed through a Board of Survey. Follow the procedures in Section H of Chapter 6 in this handbook.

Don't reuse the catalog numbers of deaccessioned reproductions.

Note: If the original is badly deteriorated, you may want to keep the reproduction.

B. Living History Items

1. *Are living history items part of the museum collection?*

The park will manage original objects and reproductions that it acquires exclusively for living history separately from the museum collection.

No. Living history items are not left on exhibit. Parks must store them in a separate location from the museum collections and manage them according to the personal property system.

If objects on exhibit are also used for living history, you must accession and catalog them and get approval for consumptive use.

Remove living history materials that have been inappropriately accessioned into the museum collection. Refer to Section B of Chapter 6 in this handbook for information on removing non-museum property from the collection.

2. *How does the park document living history items?*

Clearly and permanently mark living history items with the words "Living History." Mark them in an accessible, but not obtrusive, location. The park should account for living history items through the personal property system. See the *Personal Property Management Handbook No. 44*.

C. Exhibition Aids

1. *What's the difference between reproductions and exhibit aids?*

Reproductions are exact or close imitations of museum objects. Exhibit aids or props are produced or acquired to create an exhibit. Exhibit aids aren't intended to be original or reproduction museum objects. Examples of exhibit aids include:

- exhibit cases and mounts
- molded plastic fruit
- curtain rods (non-historic)
- panels and dioramas
- display panels
- photographs and other display art

2. *Do I need to accession and catalog exhibit aids and props?*

No. Don't accession and catalog exhibit aids and props. In rare cases, you may want to accession and catalog old exhibit material as examples of:

- notable craftsmanship
- park history
- exhibit techniques or interpretive approaches

D. Outdoor Exhibits

1. *Do I catalog objects in outdoor exhibits?*

Yes. Accession and catalog movable objects that are in outdoor exhibits and are not incorporated in a fixed monument. These include cannons, carriages, wagons, farm equipment, and automobiles.

2. *Do I catalog fixed outdoor monuments?*

No. The List of Classified Structures (LCS) defines fixed outdoor monuments as structures. Refer to *Cultural Resource Management Guideline*, Chapter 8, Management of Historic and Prehistoric Structures, for other examples of structures.

Section V. Consumptive Use of Museum Objects

A. Overview

1. *What is consumptive use?*

Consumptive use is the use of museum objects in a way that may damage them or make them deteriorate more quickly. It includes:

- subjecting objects to unacceptable possibilities of wear, breakage, theft, deterioration, or destruction
- destructive and scientific analysis
- use of objects in interpretive programs

Note: Exhibiting objects is not considered consumptive use.

2. *Where can I find NPS guidelines on consumptive use of museum objects?*

The guidelines for consumptive use are in the *Cultural Resource Management Guideline*, Chapter 9, Management of Museum Objects.

Refer to *MH-III*, Chapter 1, Evaluating and Documenting Use, for more information on consumptive use of collections.

Refer to Chapter 6 in this handbook for information on deaccessioning objects that have been entirely destroyed in analysis.

Refer to Director's Order #24: NPS Museum Collections Management.

B. Consumptive Use Approval

1. *Who approves consumptive use?*

The superintendent can authorize in writing destructive or scientific analysis except for rare or highly significant objects, specimens, and archival materials.

The superintendent must send destructive or scientific analysis requests that involve rare or significant objects to the regional director for approval. The regional/SO curator, archeologist, or natural history specialist should review these requests.

The superintendent must send all other requests for consumptive use to the regional director for approval. Refer to the *Cultural Resource Management Guideline* for the specific information that the superintendent must include in the request.

2. *When is consumptive use acceptable?*

Destructive or scientific analysis is a legitimate use of museum collections for approved research purposes. The research purpose must be based on a professional research design that clearly documents the need for the analysis.

Note: New and developing non-invasive technologies for analysis are preferable to analysis that destroys or alters all or part of an object or specimen.

3. *When is consumptive use not acceptable?*

With the exception of destructive or scientific analysis, consumptive use is generally not acceptable for museum collections. In most cases, you should use a reproduction rather than expose objects to unacceptable wear, deterioration, destruction, or loss. In rare instances, the NPS may permit consumptive use of museum objects after careful review and approval.

The superintendent must justify the request for consumptive use by stating to the regional director:

- how the use will benefit the public, increase understanding and appreciation of cultural and natural heritage, or contribute significantly to heritage preservation and protection
- why the park can't use reproductions of the original or a similar object

4. *Are there types of materials for which the regional director won't grant permission for consumptive use?*

Yes. The regional director won't grant permission for consumptive use if the objects are:

- directly connected with or prime survivors from the park's historic periods, events, or personalities
- type specimens or one-of-a-kind natural history specimens
- from systematic archeological collections that have known site provenience or scientific value that hasn't yet been documented
- of scientific interest

Note: The Director may grant an exemption for this material.

There will be no exemptions for the consumptive use of:

- NAGPRA material, unless the affiliated cultural group has approved the use
- original firearms

Section VI. Following Regulations for Cataloging Natural History Specimens

A. Overview

1. *Where can I find information on collection permits for natural history specimens?*

Title 36 of the Code of Federal Regulations, Chapter 1, Part 2, Section 2.5 (Revised 1984) governs collection permits for natural history specimens. 36 CFR 2.5, Research Specimens, outlines specific conditions that govern specimens and related data that are:

- collected on park lands, *and*
- placed in museum collections or on display

In Section 2.5g, the regulation states:

(g) Specimen collection permits shall contain the following conditions:

(1) Specimens placed in displays or collections will bear official National Park Service museum labels and their catalog numbers will be registered in the National Park Service National Catalog.

(2) Specimens and data derived from consumed specimens will be made available to the public and reports and publications resulting from a research specimen collection permit shall be filed with the superintendent.

(h) Violation of the terms and contents of a permit issued in accordance with this section is prohibited and may result in the suspension or revocation of the permit.

Note: The Secretary's regulations on the preservation, use, and management of fish and wildlife are found in 43 CFR Part 24. Regulations concerning archeological resources are found in 43 CFR, Part 3.

2. *How can I help collectors with 36 CFR 2.5 compliance?*

Supply the collector with the NPS requirements, guidelines, and supplies listed in question B.4 of this section.

3. *Who is considered a collector?*

Collectors include outside researchers, contractors, and NPS employees.

B. Documenting Natural History Collections Collected Under 36 CFR 2.5g

1. *Who accession natural history specimens collected under 36 CFR 2.5g?*

The NPS must accession specimens collected under 36 CFR 2.5g. Assign one accession number to each project, and accession the specimens as a field collection. Refer to Chapter 2 in this handbook for information on accessioning.

The collector must give you information for accessioning the specimens. You must assign an accession number to the collection, and give the number to the collector.

2. *Who catalogs specimens stored in the park or a NPS repository?*

NPS curatorial staff usually catalog specimens stored in parks or NPS repositories. However, the superintendent may add a condition to the permit to make the collector responsible for cataloging.

In most cases, the collector will be responsible for cataloging specimens that go into a non-NPS repository. In some cases the non-NPS repository may be responsible.

3. *Who catalogs collections stored in a non-NPS repository?*

The collection permit should include a statement that the collector must:

- give the park accession information
- catalog the specimens into ANCS+ or in an export format that can be easily imported into ANCS+ (including data for all the mandatory

fields)

- complete the NPS labels for the specimens
- submit copies of all field notes, data, reports, and other records that relate to the specimens and the collecting project

4. *What materials for documenting collections must I give to the collector?*

Before the end of the project, you must give the collector:

- an accession number for the collection
- a supply of appropriate NPS natural history specimen labels or instructions on how to print the labels from ANCS+
- copies of the *MH-II*, Chapter 3, Cataloging; Appendix H, Natural History; and Appendix I, Lot Cataloging
- the *ANCS+ User Manual*, the ANCS+ program, and sample copies of ANCS+ natural history worksheets

5. *Do I have to buy an additional copy of ANCS+ to give to the collector?*

No. Collectors may use a park's ANCS+ site license for work they are doing for the park. Have the collector complete the contractor agreement form that you received from Re:discovery Software, Inc., the vendor for ANCS+. Contact the company at 804-975-3256 if you need a copy of the form.

Make sure that your park purchased a support plan that includes the collector's work station(s). You may have to buy additional support.

A non-NPS repository can keep the ANCS+ software as long as it's storing and managing NPS collections. If the collections leave the repository, the repository must return its copy of ANCS+ to the park.

6. *What fields on the catalog record must the collector complete?*

The collector must complete or supply data for the following fields in ANCS+:

- Classification
- Specimen Name (scientific name)
- Lot Quantification
- Collection Site
- Township/Range/Section **or** UTM Coordinates **or** Latitude/Longitude
- Collector
- Collection Number
- Collection Date
- Identified By and Date
- Formation (for geology)
- Period/System (for geology and paleontology)

- Condition
- Type (if designated)
- Description
- Preservative and/or preparation

The park may require the collector to provide additional information. If the collector is doing the cataloging, he/she will also need to complete the following mandatory fields:

- Accession Number
- Catalog Number
- Cataloger
- Controlled Property
- Location
- Object Status
- Status Date

Refer to Chapter 2 in the *ANCS+ User Manual* for information on the catalog fields for natural history specimens.

7. *May I release catalog numbers to the collector?*

Yes. You may release catalog numbers for use with the project if the collector:

- provides a list or estimate of items to be cataloged
- has knowledge of the NPS cataloging system

Don't release catalog numbers before the field collecting activity takes place.

Track the catalog numbers that you issue for each accession. Include lists of catalog numbers and object names in the appropriate accession folders.

Follow up to make sure that the collector has:

- used all the numbers
- properly assigned the numbers to objects
- entered catalog records into ANCS+ or in an export format for import into ANCS+

8. *Who is responsible for cataloging the field records?*
- The park is responsible for cataloging field records. Refer to Chapter 2 in the *ANCS+ User Manual* for information on cataloging archival collections.
- Note:** The collector might not turn the field records over to the park until he/she has published or produced a final report. This may take several years. The park should track outstanding field records until the collector turns them over to the park.
- Refer to Chapter 2 in this handbook for information on copyrights and field records.
9. *Who is responsible for monitoring the accuracy of the records?*
- The collector should send the completed electronic database to you for review. The contract should state that the collector must make corrections or changes to the database based upon your review. It's a good idea to review the database at intervals so that you can catch problems early.
10. *What documentation must the collector submit to you?*
- The collector must submit:
- approved electronic copies of the catalog records (if the collector is required to catalog the specimens as a condition of the permit)
 - original or reproducible copies on archival quality paper of all field notes and reports (see question 8 above)
- Note:** When the park submits the records to the National Catalog, the National Catalog will print paper copies of the catalog records at the park's request. The collector may print paper copies of the catalog records, but printing paper records is optional.
11. *Who prepares the NPS natural history labels and marks the specimens?*
- If the collection is going into a non-NPS repository, the collector prepares the NPS natural history labels and marks the specimens. The collector is responsible for adding accession and catalog numbers to the labels and marking the specimens with the catalog number. See Appendix J in this handbook for marking techniques. Appendix H of this handbook has information on natural history labels.
- Use the field collection number as a reference until the collector marks the catalog number on the specimen. The field specimen number is on the specimen and the accession and catalog records.
- Note:** If the collections are going into a NPS repository or a park, NPS staff complete the labels and mark the specimens.

C. Natural History Collections on Loan to Non-NPS Repositories

1. *When do I place a natural history collection on loan to a non-NPS repository?*

Many collectors will want to move the collection to their institution at the end of the field collecting period. You may place collections on outgoing loan to a non-NPS repository. If the specimens have not been cataloged, list specimens by accession number and collecting number or groups of similar specimens. Find out the size of the collection. Tell the collector that you will prepare a complete list of specimens for the loan agreement after the collection is fully processed. Follow the procedures for repository loans in Chapter 5 of this handbook. Make arrangements for the collector or non-NPS repository to process and catalog the specimens.

2. *Am I responsible for monitoring the loan?*

Yes. You must periodically monitor the condition of the collections at the borrowing repository. You may supply the borrowing institution with copies of the *MH-I*, Museum Collections.

You will also monitor collections on loan through the annual inventory. See Section I of this chapter and Appendix F in the *ANCS+ User Manual* for information on the annual inventory.

Section VII. Buying Insurance for Borrowed Objects

A. Overview

1. *Why do I need to insure museum objects that I borrow?*

Non-federal museums, private owners, and state or local agencies generally require insurance coverage as a condition for a loan. Insurance is a means of financial compensation if loss and damage occur from unexpected causes. These include fire, smoke, water, flood, vandalism, theft, or shipping damage.

Insurance is not a substitute for good collections management.

2. *Do I need to insure items left at the park for identification?*

No. Generally you don't insure items if they are left at the park for the benefit of the owner. But if the owner could show that government negligence resulted in loss or damage, the owner could file a tort claim. It is wise not to take custody of such items in the first place.

3. *Do I need to insure property of the United States Government?*

No. The U.S. Government assumes its own risks. You don't need to insure your park's collection. You don't need to insure museum collections you borrow from other parks or from other government agencies unless the agency requires insurance.

Note: This doesn't apply to Smithsonian Institution collections that are held in trust by the Institution for the general public (20 USC 41). Smithsonian loan agreements require one of the following:

- insurance to be carried by the Smithsonian and the premium billed to the park

- insurance to be carried by the park
- insurance waived if the park agrees to indemnify (financially back) the Smithsonian for any and all loss or damage to the objects

The last option is unacceptable for the NPS. Government employees aren't authorized to obligate government funds in advance of appropriations (31 USC 665a, 35-CG-85). It's most convenient for you to use the Smithsonian Institution policy. Refer to question B.3 in this section. Consult with the registrar of the appropriate Smithsonian Institution museum for additional information.

4. *What is a tort claim?*

A non-federal owner of an uninsured museum object that's lost or damaged while in NPS custody can file a tort claim against the government for the cost of replacement. To receive a monetary judgement, the plaintiff must prove that the government was negligent or committed a wrongful act. Tort claim procedures are described in the Federal Tort Claims Act (28 USC 2671-2680, as amended).

It's in the lender's best interest to require insurance coverage for borrowed material rather than rely on a tort claim. Tort Claims Act coverage isn't insurance. An insurance policy keeps the lender from filing a tort against the government to recoup losses on damaged or lost museum collections.

B. Buying Insurance

1. *Can the NPS buy insurance?*

Yes. As a result of two Comptroller General decisions (17-CG-55 and 42-CG-392), you can buy insurance when non-federally owned property is in NPS temporary custody. "Where privately owned property is temporarily entrusted to the custody of the Government for public purposes, the cost of insuring such property may be paid from applicable appropriations." (17-CG-55)

You can either use the lender's policy or buy private insurance.

2. *Who pays for the insurance?*

You, as the borrower, are responsible for paying insurance costs unless explicitly agreed to otherwise in writing. Whether you use the lender's policy or buy private insurance, you'll need to submit a requisition for the premium amount.

You can also have your park cooperating association pay the premium. If the association pays the premium, the policy must list the park as the insured.

The value of the insured property may increase over time and the insurer may raise the insurance premium yearly. You will have to budget for these increases. Regularly review the values of the items on loan to make sure they reflect current market value. If you have any questions, contact the regional/SO curator.

3. *How do I use the lender's policy?*

If you use the lender's insurance you'll be billed the premium costs for the loan period. Be sure to:

- get a waiver of subrogation from the insurance company, *or*
- have the park named as an additional insured in the lender's policy

4. *What is a waiver of subrogation?*

Subrogation is a clause in an insurance policy that allows the insurer the rights to any possible legal action. A waiver of subrogation is an assurance by the insurer that it won't subrogate against a third party. If you don't have a waiver of subrogation, the insurance company can recoup its losses by suing the park as a third party. Without a waiver of subrogation, the insurance company could pay the lender and then claim compensation from your park.

The insurance policy should state that the company won't attempt to recover any loss from:

- your park
- any other institution borrowing the covered museum property

5. *What is a certificate of insurance?*

If you're using the lender's policy, you can get a certificate of insurance with the United States and your park named as additional insureds. This puts the park in the same category as the original holder of the policy. The park has to follow the terms of the lender's policy. Put a copy of the policy terms and the certificate of insurance in the loan or accession folder. Send a copy of the documents to your contracting officer.

6. *How do I buy an insurance policy to cover the items I borrow?*

You can arrange with an insurance company to buy museum collections insurance for the items you borrow. Look for a company or agent with experience in insuring museums or fine arts. You'll be billed for the premium costs for the period of the loan. Make sure the policy you buy is a "museum collections policy" as listed in the *Fire, Casualty and Surety Bulletins* (specialty lines Section Fa-1) published by the National Underwriters Company.

Don't get a fine arts dealers policy because the coverage is not as comprehensive as museum collections insurance.

C. Insurance Policies

1. *What standard features must an insurance policy include?*

Make sure the policy you buy for the objects you borrow includes these standard features:

- ***Limits of Liability***

The policy outlines the limits of liability. They refer to the:

- maximum amount of coverage the insured (individual or organization) can collect, *or*

- the maximum amount to be paid out in the case of loss or damages

The limits of liability should correspond to the actual dollar values of the museum objects shown on the loan agreement. Liability limits established at less than the total value could result in problems for the park in the event of loss or damage.

- ***Wall to Wall Coverage***

The policy must include a clause that shows protection for objects is “wall to wall” or “nail to nail.” This means that property is covered from the time it leaves its normal repository until it’s returned. The policy will be in effect during packing, shipping, temporary storage, and during the period of the loan.

- ***Perils Insured***

All policies should be “All-Risk.” This means the insured is protected against all loss or damage arising from an external cause. The policy must list any specific exclusions for which the insurer won’t pay damages.

- ***Exclusions***

Exclusions are circumstances for which the policy will deny coverage. The policy must spell out all exclusions. Make sure you understand what they are.

Standard exclusions are:

- normal wear and tear (damage caused by usual day-to-day handling)
- gradual deterioration (the effects of time)
- insects, moths, and rodents
- inherent vice (a quality in an object which causes it to deteriorate or destroy itself)
- damage due to or resulting from repair, restoration, or retouching
- nuclear reaction, radiation, or radioactive contamination
- insurrection and war
- government confiscation

You can negotiate to remove standard exclusions if a particular exclusion is not advantageous to the park. This may involve additional expense. If you do negotiate the additional coverage, make sure it’s noted on the loan agreement.

- ***Waiver of Subrogation***

Any insurance policy that you purchase to cover museum collections that you borrow should include a waiver of subrogation for other museums. Museum insurance policies should include this waiver as a courtesy to maintain trust between institutions.

Refer to question B.4 in this section for information on a waiver of subrogation.

- ***Valuation***

The lender usually places the monetary value on the museum objects in the loan. However, you need to make sure that the insurance value is reasonable. You and the lender must agree on the dollar amount before signing the loan agreement. The value should be the same as the fair market value at the time of the loan.

Insurance coverage should not be less than the amount noted in the loan agreement.

Note that the value of the insured property may increase over time. The insurer may also raise the insurance premium yearly.

- ***Claims***

The policy should have procedures for handling claims. These include information on who you should notify after a loss and how soon after a loss you should notify them. Don't accept a requirement that notice of loss must be made immediately after loss or damage occurs. Substitute the phrase "as soon as practical."

- ***Deductibles***

Don't accept a deductible when insuring borrowed objects. Insure the full value of the object to protect the park and the lender in the event of loss. Deductibles are a feature used to cut costs. Museums commonly use them to insure permanent collections but don't use them for loans.

- ***Buy back provision***

The policy should include a "buy-back" provision. This allows the insured to buy back a lost or stolen item that is recovered after the claim has been paid. It is the right to buy back the item from the insurance company.

Insurance companies are flexible in meeting the needs of potential customers. Don't hesitate to ask a company to add the provisions that you want.

2. *Do I need to update an existing insurance policy?*

Review insurance arrangements for current loans at the time of renewal to determine if there is proper coverage. Update the policy if necessary.

Section VIII. Completing the Collections Management Report

A. Overview

1. *What is the Collections Management Report?*

The Collections Management Report (CMR) gives information on the size of your museum collection and collection activity during the fiscal year. The report tracks accessions, deaccessions, cataloging, and use of collections.

2. *What is the purpose of the CMR?*

The CMR allows you to see changes in your collection from year to year. It assists the regions and the Washington office in measuring program activity and managing collections. The NPS and Department of Interior (DOI) use CMR numbers to produce Servicewide statistics and departmental reports on museum collections. The NPS has successfully used CMR statistics to justify requests for funding to complete the cataloging backlog. The CMR also supplies the numbers for Government Performance and Results Act (GPRA) reporting on Strategic Plan Goal Ib2D. The goal is to increase the number of NPS museum objects that are cataloged.

3. *Who completes the CMR?*

The staff person responsible for the museum collection completes a CMR each fiscal year.

4. *When is the CMR due?*

You must complete your CMR at the end of each fiscal year. The fiscal year runs from October 1 through September 30.

You must submit an electronic copy of your CMR to the Museum Management Program (MMP) in Washington by November 1.

5. *How do I complete the CMR?*

You must complete the CMR using ANCS+. Refer to Appendix E in the *ANCS+ User Manual* for instructions on using the program. If your previous year's CMR is accurate, and you keep your databases up-to-date, ANCS+ produces an accurate CMR for you.

6. *What's the relationship between the CMR and GRPA?*

Strategic Plan Goal Ib2D measures the number of items entered into ANCS+ and submitted to the National Catalog. The certified data for Goal Ib2D, which is reported in compliance with GRPA, comes directly from the CMRs that parks and centers submit. The certified data are the number of objects cataloged. The number comes from your CMR, Section III, Part A: Total Objects Cataloged plus the number of objects that centers have cataloged during the fiscal year for your park. This is the park's certified data for Goal Ib2D.

B. Reporting Center Collections

1. *Does the CMR include the objects I have at NPS centers and non-NPS repositories, such as universities?*

Yes. Your park CMR represents your entire collection. Your park CMR shows all the museum objects that your park owns, including those that aren't physically located at the park.

If you have collections at NPS centers, the CMR that the park prepares doesn't include the current fiscal year's cataloging and other activities, such as research use, that the center has managed for your park. The MMP will send the park a summary report that includes this activity.

Note: You should have loan agreements for the objects at other facilities. Refer to Chapter 5 in this handbook for information about repository loans.

2. *Who completes the CMR for the collections I have at NPS centers?*

NPS center staff complete a CMR for each park collection at the center. The centers complete these reports each fiscal year and submit them to the MMP. Center CMRs represent only the portion of the park collection that is on loan to the center. The center report for your park tells you the number of cataloged objects, the catalog backlog, and the collection size for those park items on loan to the center. It also tells you the number of objects that the center cataloged for your park during the fiscal year.

Note: Don't double report cataloging. The park report should show only the fiscal year cataloging done at the park. Don't add the center's fiscal year cataloging to your CMR. The center's cataloging appears on the center's CMR for your park. The MMP completes a park summary report that combines the cataloging totals and sends it to the park.

3. *Who completes the CMR for collections I have at non-NPS repositories?*

In 1994, the Interior Museum Program did a survey of non-federal repositories that hold federal collections. Your region received the results of this survey with its summary CMR for FY 1999.

<i>If...</i>	<i>Then...</i>
your park has museum items in a non-federal repository,	you should contact the institution and include the items in your park CMR.
the non-federal repository supplies extensive collections management services to your park that includes the use of ANCS+,	you may submit a separate CMR for that institution.

Note: If the repository completes the report, it must send the CMR to you for submission.

4. *Do I need to combine a center or repository CMR with my park CMR?*

No. If the center or repository that submits a CMR cataloged collections for your park, the MMP will create a summary report for your park. The summary report combines the number of items the center cataloged during the fiscal year with the number of items the park cataloged. The MMP will send the summary CMR back to you. The MMP also produces summary reports for centers, clusters, and regions, and a Servicewide summary.

5. *What do I do with the summary report for my park?*

The MMP will send an electronic copy of the summary report directly to your park.

When you receive your summary report, upload it into ANCS+ to update your baseline cataloging data. You must do this before running your next CMR.

C. CMR Program

1. *What does the CMR program do?*

The CMR program in ANCS+ will:

- extract your last year's CMR data
- extract the current fiscal year's data from ANCS+
- allow you to adjust the data
- total your data
- maintain your CMR data from previous years
- print the CMR, Form 10-94 Rev. (Figure 4.6)
- allow you to submit the CMR files electronically

2. *Will running the CMR program change any of my ANCS+ data?*

No. The CMR extracts information from existing records but doesn't modify them. You can't change your records from the CMR. You must go to the appropriate database to make changes to your data.

3. *What if I have different collections within my park?*

The CMR allows you to extract data from different directories. You can run individual reports for each park collection that you manage. You can also run one report that combines the data for all the collections at the park under one acronym.

4. *What is the structure of the CMR?*

The CMR has three sections:

- Section I. Total Collection Summary From Previous Year (this should be your previous year's CMR data or the data that you uploaded from your park summary report)
- Section II. Collection Summary For Fiscal Year, which has four parts:
 - A. Accessions
 - B. Deaccessions
 - C. Cataloging
 - D. Use of Collections
- Section III. Total Collection Summary For All Years

5. *How does the CMR program count cataloged objects?*

The CMR program counts objects in three ways. The program:

- counts the number of individual items if an exact item count is available
 - counts bulk units, such as boxes or bags, as one item, if an exact item count isn't available
 - multiplies the number of linear or cubic feet by 1600 to get an item count for archival collections
-

D. Completing the CMR

1. *What are the steps in completing the CMR?*

To complete the CMR:

- Enter the park, year, and directories for the report you're creating, and have the program extract the data for the report.
- Adjust the numbers from the previous year's CMR, if needed.
- Review the numbers that the program has extracted in the various sections of the report. Make adjustments and add explanations as needed.
- Enter the information on who completed the report.
- Print the report and have the superintendent sign it. File the signed copy.
- Submit an electronic copy of the report by November 1 to the Museum Management Program.
- Update the CMR if you receive a park summary from the MMP.

Note: Specific instructions for completing these steps are in Appendix E of the *ANCS+ User Manual*.

2. *How does ANCS+ create my CMR?*

ANCS+ uses the numbers you reported on last year's CMR (or your summary CMR) as its baseline. The program then adds the numbers for transactions such as new accessions, deaccessions, and cataloging to those totals.

3. *Why would I need to make adjustments to my CMR?*

There are many reasons to make adjustments to your CMR. For example, you might need to adjust accession numbers if you incorrectly estimated the number of items in an accession. It's important to add notes that explain why you made the adjustments.

4. *What do I do if I think the data in my CMR are incorrect?*

ANCS+ has several verification reports that you can run to see how the program pulled the numbers for your report. Run the reports, and then adjust your data as needed, or make changes to your database and rerun the CMR. You may need some of the following information to assist you in verifying your data:

- previous year's CMR
- previous year's CMR from centers or your park summary report that includes center data
- park accession book
- park deaccession book or files (if your park uses these)
- catalog number log book (if your park uses one)
- outgoing loan records
- researcher access records

5. *What are the data fields in Section I of the CMR?*

The fields in Section I of the CMR show the data from your previous year's CMR. The fields are divided by discipline: archeology, ethnology, history, archives, biology, paleontology, and geology.

Objects Cataloged

This field includes the total number of cataloged items and the number of items cataloged by discipline. You can make adjustments to this field.

Catalog Backlog

This field includes the total number of items that need to be cataloged and the number of items that need to be cataloged by discipline. You can make adjustments to this field.

Total Collection

This field includes the total number of items in the park's collection and the total number of items in each discipline. The program automatically tallies the totals.

Notes

Use this field to enter explanations for adjustments you make.

Note: Section I of your current year's CMR should be the same as Section III of your previous year's CMR. Changes you make on your current CMR won't change your previous year's CMR. To make changes on your previous year's CMR, you must go to the report in ANCS+, modify it, and save it. If you make modifications, be sure to resubmit the CMR.

6. *What are the fields in Section II.A of the CMR?*

The fields in Section II.A of the CMR record the number of items you accessioned during the fiscal year of the report.

Objects Accessioned (By Acquisition Type)

This field includes the total number of items that you accessioned and the number of items you accessioned by acquisition type. The acquisition types are: gift, exchange, purchase, field collection, transfer, and incoming loan. The program automatically tallies the totals. You can make adjustments to this field.

Notes

Use this field to enter explanations for adjustments you make.

Objects Accessioned (By Discipline)

This field includes the total number of items that you accessioned and the number of items you accessioned by discipline. The acquisition types are: gift, exchange, purchase, field collection, transfer, and incoming loan. The program automatically tallies the totals. You can make adjustments to this field.

Notes

Use this field to enter explanations for adjustments you make.

Note: The total number of items accessioned by acquisition type must equal the total number of items accessioned by discipline.

7. *What are the fields in Section II.B of the CMR?*

The fields in Section II.B of the CMR record the number of items you deaccessioned during the fiscal year of the report.

Objects Deaccessioned (By Deaccession Type)

This field includes the total number of items that you deaccessioned and the number of items you deaccessioned by deaccession type. The deaccession types are: exchange, transfer, loss, theft, loan return, NAGPRA, conveyance, involuntary destruction, voluntary destruction, return to rightful owner, and destructive analysis. The program automatically tallies the totals. You can make adjustments to this field.

Notes

Use this field to enter explanations for adjustments you make.

Objects Deaccessioned (By Discipline)

This field includes the total number of items that you deaccessioned and the number of items you deaccessioned by discipline. The disciplines are: archeology, ethnology, history, archives, biology, paleontology, and geology. The program automatically tallies the totals. You can make adjustments to this field.

Notes

Use this field to enter explanations for adjustments you make.

Note: The total number of items deaccessioned by deaccession type must equal the total number of items deaccessioned by discipline.

8. *What are the fields in Section II.C of the CMR?*

The fields in Section II.C of the CMR record the number of items you cataloged during the fiscal year of the report.

Objects Cataloged

This field includes the total number of items you cataloged and the number of items you cataloged by discipline. The disciplines are: archeology, ethnology, history, archives, biology, paleontology, and geology. You can make adjustments to this field.

Notes

Use this field to enter explanations for adjustments you make.

Note: Include only those records that you will be submitting for this fiscal year to the National Catalog. To qualify as new cataloging, this must be the first time that you submitted the records.

9. *What are the fields in Section II.D of the CMR?*

The fields in Section II.D of the CMR record information about use of the collection.

Total Number of Outgoing Loans

This field shows the total number of outgoing loans that were active during the fiscal year. You can make adjustments to this field.

Include all loans to NPS centers and non-NPS repositories. You should have a loan agreement for any items that aren't located at the park.

Total Number of Objects in Outgoing Loans

This field shows the number of objects in outgoing loans during the fiscal year. You can make adjustments to this field.

Total Objects in Exhibits

This field shows the number of objects on exhibit during the fiscal year. You can make adjustments to this field.

Total Number of Research Requests Within Park

This field shows the total number of research requests that park staff made during the fiscal year. Include all inquiries about the collection.

Total Number of Research Requests From Outside Park

This field shows the total number of research requests that outside researchers made during the fiscal year. Outside researchers include anyone from outside the park, such as the general public, scientists, scholars, teachers, students, and journalists.

Note: The number of research requests is important. You can use these numbers to justify the need for museum staff to handle the requests. The MMP submits these numbers to DOI and Congress to show the amount of research being done using NPS collections.

Notes

Use this field to enter explanations for adjustments you make.

10. *What are the fields in Section III of the CMR?*

The fields in Section III of the CMR show the most current data for your collection. The program automatically tallies the data for this section from the data in Sections I and II. You can't make adjustments to the data in this section. If you need to adjust the data, you must make the adjustments in Sections I and II of the report.

The fields are divided by discipline: archeology, ethnology, history, archives, biology, paleontology, and geology.

Objects Cataloged

This field includes the total number of cataloged items and the number of items cataloged by discipline.

Catalog Backlog

This field includes the total number of items that need to be cataloged and the number of items that need to be cataloged by discipline.

Total Collection

This field includes the total number of items in the park's collection and the total number of items in each discipline.

These numbers should be an accurate representation of all the museum objects that your park has. The park CMR should include the objects that centers and repositories store and manage for your park.

Notes

Use this field to enter explanations about the current collection.

Noteworthy

Use this field to describe important accessions and deaccessions. If you reported losses and/or thefts, include the total value of the objects, if known. You may want to list major achievements in documenting the collection.

Be sure to include an explanation of any major adjustments that you've made. This information will print on the CMR, Form 10-94 Rev. (Figure 4.6).

Completion Information

The fields in this section of the CMR tell you the:

- name, title, and phone number of the person who completed the report
 - date the report was completed
 - the name of the person who approved the report
-

E. Submitting the CMR

1. *Do I need to print my CMR?*

Yes. Print the CMR, Form 10-94 Rev. (Figure 4.6) and have the superintendent or center manager sign it. By signing the CMR, the superintendent is certifying that it is a correct representation of the park museum collection.

Keep the signed paper copy on file with your museum records.

2. *Do I need to submit a paper copy of my CMR?*

No. Don't submit a paper copy of your CMR. You must submit an electronic copy of your CMR using ANCS+. Refer to Appendix E of the *ANCS+ User Manual* for instructions on submitting an electronic copy of your CMR.

3. *Does anyone need to review my CMR before I submit it?*

It's a good idea to have your regional/SO curator review your CMR. Some regions may require you to do this.

If you have collections at a center, the center should send you a review copy of the center's CMR for your park collection.

Section IX. Determining the Monetary Value of Museum Objects

A. Overview

1. *What kinds of value do museum collections have?*

Museum collections have scientific, cultural, historic, educational, and esthetic value in addition to their monetary value. NPS collections, in particular, have high associative value. The items in NPS collections are associated with the people, events, and natural features that the park commemorates. These types of values make many museum items irreplaceable and invaluable.

2. *When would I want to assign a monetary value to museum objects?*

Assigning monetary values to museum objects can be an important part of collections management. You can use monetary values to:

- determine replacement value for insuring outgoing loans
- document that an exchange of museum objects is equitable
- choose which objects will be controlled property
- justify protection and preservation actions
- determine loss in case of damage or theft
- confirm purchase price or the monetary value of an acquisition
- document a proposed deaccession

Note: In the case of theft, law enforcement bases the level of investigation on the monetary value of the object.

You must get a formal monetary appraisal for objects in an exchange if the exchange is with individuals or institutions outside the federal government. Refer to Chapter 6 in this handbook for information on exchanges.

3. *What types of collections don't have a monetary value?*

Curators and discipline specialists are usually reluctant to give a monetary value to most natural history and archeological collections. However, certain archeological, paleontological, and geological items have a very high monetary value in the current market. It's important to give these items a monetary value.

A monetary value may be inappropriate for NAGPRA material and other ethnographic items of cultural significance. Consult with the culturally affiliated group before giving a monetary value to these types of materials.

B. Monetary Values

1. *What is fair market value?*

Fair market value is the price that a willing buyer and seller agree to when there is no pressure to buy or sell. Both the buyer and the seller should have a reasonable knowledge of the facts about the item for sale.

Use fair market value to determine if an exchange is equal. Donors must use fair market value to determine value for tax deduction purposes.

2. *What is replacement value?*

Replacement value is the amount of money you would need to buy a similar item at full retail cost. In the case of replacement value, the owner has no intention of selling the item.

Replacement value is appropriate for most situations in a park, such as:

- placing a value on the catalog record
- determining insurance coverage for an outgoing loan
- making management decisions about the collection

Note: The cost of conservation treatment for a site-specific, irreplaceable object may be more than the fair market or replacement value. Keep this point in mind when assigning values for outgoing loans.

3. *Do all objects have a fair market and replacement value?*

No. You can usually place a fair market or replacement value on items that frequently appear in auction sales and antique stores. These types of items include furniture, porcelain, gems, firearms, coins, jewelry, and books. For other types of material it's much more difficult to place a monetary value because of a less active market. These types of material include certain natural history and archeological items such as soil and lithic samples. These materials may possess great historic or scientific value but little or no market value.

You should know the replacement and market values for the types of material in your collection.

C. Assigning Monetary Value

1. *What makes an object valuable?*

Characteristics that affect object value include:

- condition
- rarity
- authenticity
- fashion (market demand)
- age
- provenience
- documentation

- historic association
- materials
- quality

For example, a table that General Meade used as his desk at the Battle of Gettysburg has historic association. The table will have a higher monetary value because of its association.

The condition of an object often affects its value. Missing pieces or visible repairs usually decrease value. Mint condition greatly increases value.

Sometimes the fact that a collection is complete makes it valuable, such as a collection of 1939 World's Fair bric-a-brac. The completeness of the collection is more valuable than the items within it.

2. *How does a specialist determine monetary value?*

A specialist bases the value of an object on:

- knowledge of the market value (market demand)
- particular characteristics of the piece (quality)
- verification of the date and origin (authenticity)

For example, a chest made by an 18th century cabinetmaker is more valuable than a Colonial Revival piece from the late 20th century. Features such as period hardware and structural details also affect the value.

3. *Can I assign values to museum objects?*

Yes. You can assign values to museum objects for some purposes, such as cataloging, identifying controlled property, and outgoing loans. You can't assign values for exchanges outside the federal government, tax deduction purposes, or in other cases that require a formal appraisal.

4. *What should I do before assigning a value to an object?*

An accurate identification of the object is the first step in assigning value. Once you have identified the item, you may need to:

- do research
- check auction catalogs and retail prices
- get help from NPS specialists
- consult other museum professionals or subject-matter specialists

Note: Examine the object carefully and match it as closely as possible to the examples in the auction catalogs and price guides.

5. *How can I gain expertise in market values?*

Antique shows, auctions, and educational forums are good places to learn market values. Become familiar with auction catalogs, books on collectibles, and trade journals and newsletters. Price guides offer market values for many types of specialized objects such as dolls, pewter, glass, and furniture. You should check price guides at least once a year for changes in market prices. The bibliography in Appendix L of this handbook has a list of some common price guides.

6. *What types of specialists are available in the NPS?*

Within the NPS there is a wide range of specialized knowledge of material culture. A few examples include experts in 18th century furniture, military costume, Native American baskets, and photographic processes. Contact your regional/SO curator for the names of NPS specialists who can help you determine values for objects.

7. *Must the specialist come to the park to evaluate the objects?*

No. Physical observation is the best way to evaluate objects, but specialists often can give you an approximate value from photographs. You may be able to get an approximate value to put on a catalog record or for a loan through a telephone call.

Before contacting the specialist, find out as much information as possible about the object, including the date and condition. You'll need to have a detailed description of the object. Photos must show several views and features such as wear, repairs, and maker's marks.

It's important to remember that a photograph is never as accurate as seeing the original object. For example, the painted finish on a piece of furniture may not be visible in a photograph.

D. Professional Appraisals

1. *What does a professional appraiser do?*

The term "appraise" means to place a value on, rate, or judge. A professional appraiser is an acknowledged expert who places values on objects for a fee. He/she produces a written appraisal statement that includes:

- a description of the objects
- an appraised value for the objects
- the facts that are the basis for the value

Note: An appraisal must be supported by facts. For example, many appraisers use prices from recent sales of similar objects to determine a value.

2. *When do I need to get a professional appraisal?*

You need a professional, or formal, appraisal for:

- objects of extremely high value or questionable authenticity
- an exchange of museum objects with individuals or institutions outside the federal government
- updating the value of an entire collection
- objects that are beyond the area of expertise of the curator or other NPS specialists

Note: To determine the value of an entire collection, an appraiser classifies the types of items in the collection. He/she then estimates a value for each category and totals the figures. At times, an appraiser may place a value on each item and total the values.

3. *What should I look for in an appraiser?*

You need to make sure that the appraiser you hire is qualified and ethical. You want an appraiser with a good reputation who is impartial and honest. An appraiser must have no past, present, or future interest, monetary or otherwise, in the object being appraised. For example, he/she may not be a previous owner or vendor of the object.

Look for an appraiser who is an expert in the type of collections for which you want an appraisal. If the appraiser doesn't know the material, he/she may have to do additional research that will increase the cost of the appraisal. Interview potential appraisers and ask about their training, education, experience, specialties, references, and professional memberships. Ask them about the resources they use and how they determine comparisons. You'll also want to see an example of their work. Look for appraisal reports that are complete and that show an expert knowledge of the material.

A good appraiser will be objective, professional, and businesslike. He/she will produce a well-documented report that can withstand close scrutiny.

4. *How do I find appraisers?*

Appraising objects is not a licensed profession. In fact, most appraisers are commercial dealers. There are professional appraisal organizations that regulate their members and publish directories of certified appraisers. There are also some very good appraisers who aren't members of a professional organization. You may hear about them from colleagues.

To find an appraiser, contact:

- your regional/SO curator
- other NPS curators
- museum staff from other institutions
- private collectors
- insurance agents
- a professional appraisal organization

5. *What is the American Society of Appraisers?*

The American Society of Appraisers (ASA) is an international, non-profit, independent appraisal organization. The ASA tests and certifies potential appraisers, and requires periodic recertification. The ASA also maintains a directory of certified and accredited appraisers in various categories, such as fine arts. You can search the directory on their Web site, or contact them at:

The American Society of Appraisers
555 Herndon Parkway, Suite 125
Herndon, VA 20170
703-478-2228
1-800-272-8258
<www.appraisers.org>

A second group, The Appraisal Foundation on the Web at <www.appraisalfoundation.org> is an authority on the development of appraisal standards and qualifications. Look on their Web site for information on appraisers and the appraisal process.

6. *How much does an appraisal cost?*

Appraisers used to charge a percentage of the total value of the appraised objects. The Internal Revenue Service now prohibits appraisal fees based on percentages. Many appraisers charge an hourly rate plus expenses. Appraisers working with very high value objects are normally justified in charging a rate commensurate with the value of the objects.

A park may also accept donated appraisal services as long as there is no conflict of interest. Apply the same standards to someone donating services as you would to someone you are paying.

To save on costs, several parks may want to do a joint contract for the services of an appraiser. A region or cluster may also administer a contract for appraising objects at various parks.

7. *Should I do a scope of work for the appraiser?*

Yes. Services of an appraiser usually include an on-site visit, some research, and preparation of a written report. It's a good idea to send the appraiser a written scope of work that includes the:

- date the work is to be done
- fee for the appraisal
- objects to be appraised

8. *What must I do to prepare for the appraiser's visit?*

To best use the appraiser's time, make the following preparations:

- Decide whether you want market value or replacement value (see Section B above).
- Make sure that you have physical access to the objects.
- Supply adequate lighting.
- Have relevant documentation for each object readily available. Relevant documentation includes provenience information, photographs, and catalog records.

9. *What does an appraisal report include?*

A professional appraiser's written report should include the following information:

- whether the value is fair market or replacement value
- date and place the appraiser viewed the material
- description of the objects that includes, if applicable, condition, dimensions, materials, style, technique, characteristics, title, date, artist/maker, site of origin, exhibit history, previous owners, authenticity, and value
- names of consultants
- basis for the value, such as auction house prices, current state of the market
- total value
- signature and date of the report
- statement that the appraiser certifies no interest, past, present, or future in the subject property and that the appraisal fee is not contingent on the appraised values
- personal qualifications and credentials data on the appraiser

For example, the description portion of a chair's appraisal might read:

American (New York), mahogany, Chippendale side chair, claw and ball front feet, cabriole legs, slip seat, pierced back splat, arched crest rail ending in molded ears, gadroon molding along seat edge, with pine secondary wood, seat 24" X 24", overall height 60", excellent condition, circa 1760, \$15,000.

See Figure 4.7 for a sample of a written appraisal.

10. *Can I request changes in an appraisal report?*

Yes. Read the appraisal report carefully when you receive it. It's easier to ask for changes in the report before you have paid for it. If the documentation is inadequate or there are factual errors, return the report immediately for adjustment. It's not appropriate to question the values, but you can question the appraiser's evidence or lack of documentation.

11. *Do I need to get more than one appraisal?*

If the material is very valuable, you may want to get more than one appraisal and average the values.

You must get two written appraisals for exchanges outside the federal government if the objects are over \$20,000 in value.

E. Re-Appraising Objects

1. *How often should I re-appraise the objects in my collection?*

It's important to keep the monetary values on your objects up-to-date. Continual fluctuations in the antiques and fine arts markets mean that values don't remain current. You should periodically re-examine the values on your catalog records. This is particularly important in the event of theft. The value on the catalog record will determine the type of police investigation and whether there are criminal prosecution charges.

Be aware of price fluctuations in "trendy" objects, such as dolls and Civil War material. Price increases on these types of items can be much higher than you expect.

2. *How long is a professional appraisal valid?*

Depending on the material, a professional appraisal may be valid for years or only months. The appraisals that you use in an exchange can't be more than 60 days old. For most transactions, such as acquisitions, loans, and deaccessions, you'll want a current appraisal. For most objects in storage, you'll update the value infrequently. You'll want to update the values of exhibit items and controlled property more often.

F. Documenting Appraisal Information

1. *Where do I document appraisal information on the catalog record?*

Use the Appraisals Supplemental Record in ANCS+ to document appraisal information on the catalog record. This supplemental record allows you to track changes in value. It also links the appraisal data to the name and address of the appraiser. Refer to Section I in Chapter 3 of the *ANCS+ User Manual* for information on how to enter data in this record.

Note: Information in the Appraisals Supplemental Record doesn't appear on the main catalog record screens. Information on the acquisition value and current value for an object prints on the Museum Catalog Record, Form 10-254 and 10-254B.

2. *Where should I keep appraisal reports and other written documentation on monetary value?*

Where you file appraisal information depends on the reason for the appraisal and the number of museum files you use. You can file the information in the accession folder or the optional outgoing loan folder, deaccession folder, or catalog folder. Since most appraisals are for more than one object, you may have to make copies for multiple accession and catalog folders.

G. Appraisals and Tax Deductions

1. *Can I appraise objects for tax deduction purposes?*

No. NPS staff can't give appraisals for tax deduction purposes. Donations to the NPS are tax deductible to the extent permitted by law. The Internal Revenue Service (IRS) requires donors to get a professional appraisal for items that total over \$5,000. If the donor wants to take a tax deduction, the donor is responsible for getting the appraisal.

2. *Can I refer a donor to an appraiser?*

No. You can't refer donors to specific appraisers in order to get an appraisal for tax deduction purposes. You can refer donors to the ASA and other professional associations of appraisers. You can also help donors by telling them of the IRS law that requires the appraisal.

3. *What do I need to know about the IRS and donations to my museum?*

You need to be aware of the current IRS regulations on charitable contributions of property. The IRS requires that museums acknowledge a donation that totals over \$5,000 in one year. You must complete the donee

collection?

acknowledgment portion of Form 8283, the IRS Noncash Charitable Contributions form. Refer to Chapter 2 in this handbook for additional information on appraising donations.

Note: Signing Form 8283 does not mean that you agree with the appraised value.

If you deaccession a donation within two years of receipt, you must report the deaccession to the IRS. Use Form 8282, the IRS Donee Information Return. You must include the donor's tax identification number. Refer to Chapter 6 in this handbook for additional information on tax liabilities and deaccessions.

It's against NPS policy to acquire an object with the intention of deaccessioning it.

Send the donor copies of all forms that the park files with the IRS. If requested, the park must give the IRS information on the donor and the donated property. Keep copies of all the forms you file with the IRS for a donation. File them in the accession folder.

Section X. List of Figures

Figure 4.1a	Inventory of Museum Property, Random Sample (Form 10-349)
Figure 4.1b	Inventory of Museum Property, Random Sample Continued (Form 10-349A)
Figure 4.1c	Inventory of Museum Property, Random Sample Summary (Form 10-349A)
Figure 4.1d	AIP Summary for Random Sample Inventory [Optional]
Figure 4.2a	Inventory of Museum Property, Controlled Property (Form 10-349)
Figure 4.2b	Inventory of Museum Property, Controlled Property Continued (Form 10-349D)
Figure 4.2c	Inventory of Museum Property, Controlled Property Summary (Form 10-349D)
Figure 4.2d	AIP Summary for Controlled Property [Optional]
Figure 4.3a	Inventory of Museum Property, Accessions (Form 10-349B)
Figure 4.3b	Inventory of Museum Property, Accessions Continued (Form 10-349C)
Figure 4.3c	Inventory of Museum Property, Accessions Summary (Form 10-349C)
Figure 4.3d	AIP Summary for Random Accessions Inventory [Optional]
Figure 4.4	Object Temporary Removal Slip (Form 10-97)
Figure 4.5	Report of Survey (Form DI-103)
Figure 4.6	Collections Management Report (Form 10-94Rev.)
Figure 4.7	Written Appraisal Sample

You can print all forms, except the Report of Survey (Form DI-103) from ANCS+.

NPS Form 10-349
(Feb 1994)

Highest Catalog Number Used:
Sample Size:

UNITED STATES DEPARTMENT OF THE INTERIOR
NATIONAL PARK SERVICE
INVENTORY OF MUSEUM PROPERTY
RANDOM SAMPLE

Page

_____ Park/Center

I hereby certify that I have made or caused to be made a physical inventory of cataloged museum property in or assigned to the area for which I am the "accountable officer" and that the property shown on the sheets I through 13, inclusive, reflects a true and accurate accounting of cataloged museum property assigned to my area, and, for which I am personally responsible. The property information shown on this listing, together with any additions, changes, or deletions annotated, reflects a true and accurate property inventory record as of the date of this certification.

Superintendent (Print name)

Signature

Date

I hereby certify that I have made or caused to be made a physical inventory of cataloged museum property in or assigned to the area for which I am the "custodial officer" and that the property shown on the sheets I through 13, inclusive, reflects a true and accurate accounting of cataloged museum property assigned to my area, and, for which I am personally responsible. The property information shown on this listing, together with any additions, changes, or deletions annotated, reflects a true and accurate property inventory record as of the date of this certification. I certify that, if random numbers were used, only one set of random numbers was generated, that these numbers were generated in my presence, and that these were the random numbers used in conducting this random sample inventory.

Park Custodial Officer (Print name)

Signature

Title

Date

Signatures and titles of other persons completing inventory:

I/we certify that if random numbers were used, only one set of random numbers was generated, that these numbers were generated in my (our) presence, and that these were the random numbers used in conducting this random sample inventory.

1) _____

2) _____

Print name

Signature

Title

Date

NOTE: INSTRUCTIONS FOR COMPLETING THIS FORM ARE IN THE NPS MUSEUM HANDBOOK, PART II, CHAPTER 4.

Figure 4.1a. Inventory of Museum Property, Random Sample (Form 10-349)

UNITED STATES DEPARTMENT OF THE INTERIOR
NATIONAL PARK SERVICE
INVENTORY OF MUSEUM PROPERTY
RANDOM SAMPLE
CONTINUED

Page _____

_____ Park/Center

1	2	3	4	5	6	7	8	9	10	11	12
Location	Catalog Number	Num In Use	Cont Prop	Obj Fd	Rec Fd	Loc Btu OK	Loc Redns OK	Loc 254 OK	Dam OK	Object/Specimen Name	Remarks/Condition

Figure 4.1b. Inventory of Museum Property, Random Sample Continued (Form 10-349A)

UNITED STATES DEPARTMENT OF THE INTERIOR
NATIONAL PARK SERVICE
INVENTORY OF MUSEUM PROPERTY
RANDOM SAMPLE
SUMMARY

Page

_____ Park/Center

3	4	5	6	7	8	9	10	
Num In Use	Cont Prop	Obj Fd	Rec Fd	Loc Blu OK	Loc Redis OK	10- Dam		
Totals								
							Total Objects Missing:	=Y
							Total Objects Damaged:	=N

Figure 4.1c. Inventory of Museum Property, Random Sample Summary (Form 10-349A)

RANDOM SAMPLE INVENTORY OF MUSEUM PROPERTY

TOTAL AIP CATALOG NUMBERS:

SUMMARY OF FIELDS IN AIP GENERATED DATABASE

YES NO

CATALOG NUMBER IN USE:

CONTROLLED PROPERTY:

OBJECT FOUND:

RECORD FOUND:

BLUE LOCATION OK:

REDISCOVERY LOCATION OK:

FORM OK:

DAMAGED:

TOTAL AIP CATALOG NUMBERS WITH OBJECTS(S) MISSING:

TOTAL AIP CATALOG NUMBERS WITH OBJECTS(S) DAMAGED:

TOTAL AIP CATALOG NUMBERS NOT IN REDISCOVERY:

Figure 4.1d. AIP Summary for Random Sample Inventory [Optional]

UNITED STATES DEPARTMENT OF THE INTERIOR
NATIONAL PARK SERVICE
INVENTORY OF MUSEUM PROPERTY
CONTROLLED PROPERTY

Page _____

Park/Center _____

NPS Form 10-349
(Feb 1994)

I hereby certify that I have made or caused to be made a physical inventory of cataloged museum property in or assigned to the area for which I am the "accountable officer" and that the property shown on the sheets 1 through 3, inclusive, reflects a true and accurate accounting of cataloged museum property assigned to my area, and, for which I am personally responsible. The property information shown on this listing, together with any additions, changes, or deletions annotated, reflects a true and accurate property inventory record as of the date of this certification.

 Superintendent (Print name) _____ Signature _____ Date _____

I hereby certify that I have made or caused to be made a physical inventory of cataloged museum property in or assigned to the area for which I am the "custodial officer" and that the property shown on the sheets 1 through 3, inclusive, reflects a true and accurate accounting of cataloged museum property assigned to my area, and, for which I am personally responsible. The property information shown on this listing, together with any additions, changes, or deletions annotated, reflects a true and accurate property inventory record as of the date of this certification.

 Park Custodial Officer (Print name) _____ Signature _____ Title _____ Date _____

Signatures and titles of other persons completing inventory:

1) _____

2) _____

 Print name _____ Signature _____ Title _____ Date _____

NOTE: INSTRUCTIONS FOR COMPLETING THIS FORM ARE IN THE NPS MUSEUM HANDBOOK, PART II, CHAPTER 4.

Figure 4.2a. Inventory of Museum Property, Controlled Property (Form 10-349)

UNITED STATES DEPARTMENT OF THE INTERIOR
NATIONAL PARK SERVICE
INVENTORY OF MUSEUM PROPERTY
CONTROLLED PROPERTY
CONTINUED

Page

_____ Park/Center

1	2	3	4	5	6	7	8	9	10	11	12
Location	Catalog Number	Num In Use	Cond Prop	Obj Fd	Rec Fd	Loc Bldg	Loc Redit	10-254	Dam	Object/Specimen Name	Remarks/Condition

Figure 4.2b. Inventory of Museum Property, Controlled Property Continued (Form 10-349D)

NPS Form 10-349D
(Feb 1994)

UNITED STATES DEPARTMENT OF THE INTERIOR
NATIONAL PARK SERVICE
INVENTORY OF MUSEUM PROPERTY
CONTROLLED PROPERTY
SUMMARY

Page _____

Park/Center _____

3	4	5	6	7	8	9	10
Num In Use	Cont Prop In	Obj Fd	Rec Fd	Loc Blu OK	Loc Redis OK	10- 254 OK	Dam
Total Objects Missing: = Y							
Total Objects Damaged: = N							

Figure 4.2c. Inventory of Museum Property, Controlled Property Summary (Form 10-349D)

100 % INVENTORY OF CONTROLLED PROPERTY

TOTAL AIP CATALOG NUMBERS:

SUMMARY OF FIELDS IN AIP GENERATED DATABASE

YES NO

CATALOG NUMBER IN USE:

CONTROLLED PROPERTY:

OBJECT FOUND:

RECORD FOUND:

BLUE LOCATION OK:

REDISCOVERY LOCATION OK:

FORM OK:

DAMAGED:

TOTAL AIP CATALOG NUMBERS WITH OBJECTS(S) MISSING:

TOTAL AIP CATALOG NUMBERS WITH OBJECTS(S) DAMAGED:

TOTAL AIP CATALOG NUMBERS NOT IN REDISCOVERY:

Figure 4.2d. AIP Summary for Controlled Property [Optional]

UNITED STATES DEPARTMENT OF THE INTERIOR
 NATIONAL PARK SERVICE
 INVENTORY OF MUSEUM PROPERTY
 ACCESSIONS

Page _____

ParkCenter

NPS Form 10-349B
 (Feb 1994)
 Highest Accession Number Used: _____
 Sample Size: _____

I hereby certify that I have made or caused to be made a physical inventory of uncataloged museum property in or assigned to the area for which I am the "accountable officer" and that the property shown on the sheets 1 through 4, inclusive, reflects a true and accurate accounting of uncataloged museum property assigned to my area, and, for which I am personally responsible. The property information shown on this listing, together with any additions, changes, or deletions annotated, reflects a true and accurate property inventory record as of the date of this certification.

I am aware that this inventory represents a substandard level of accountability because the property is not cataloged.

Superintendent (Print name) _____ Signature _____ Date _____

I hereby certify that I have made or caused to be made a physical inventory of uncataloged museum property in or assigned to the area for which I am the "custodial officer" and that the property shown on the sheets 1 through 4, inclusive, reflects a true and accurate accounting of uncataloged museum property assigned to my area, and, for which I am personally responsible. The property information shown on this listing, together with any additions, changes, or deletions annotated, reflects a true and accurate property inventory record as of the date of this certification. I certify that, if random numbers were used, only one set of random numbers was generated in my presence, and that these were the random numbers used in conducting this random sample inventory.

Park Custodial Officer (Print name) _____ Signature _____ Title _____ Date _____

Signatures and titles of other persons completing inventory:
 I/we certify that if random numbers were used, only one set of random numbers was generated, that these numbers were generated in my (our) presence, and that these were the random numbers used in conducting this random sample inventory.

1) _____

2) _____

Print name _____ Signature _____ Title _____ Date _____

NOTE: INSTRUCTIONS FOR COMPLETING THIS FORM ARE IN THE NPS MUSEUM HANDBOOK, PART II, CHAPTER 4.

Figure 4.3a. Inventory of Museum Property, Accessions (Form 10-349B)

**UNITED STATES DEPARTMENT OF THE INTERIOR
NATIONAL PARK SERVICE
INVENTORY OF MUSEUM PROPERTY
ACCESSIONS
CONTINUED**

Page _____

_____ Park/Center

1 Location	2 Accession Number	3 Num In Use	4 Rec Ft	5 Cataloged Status	6 Obj	7 Dam Fd	8 Remarks/Condition

Figure 4.3b. Inventory of Museum Property, Accessions Continued (Form 10-349C)

UNITED STATES DEPARTMENT OF THE INTERIOR
NATIONAL PARK SERVICE
INVENTORY OF MUSEUM PROPERTY
ACCESSIONS
SUMMARY

Page _____

_____ Park/Center

	3		4		5		6		7	
	Num In Use	Rec Fd	Num In Use	Rec Fd	Cataloged Status		Obj Fd	Dam		
Totals					N= P=	F= D=				
									=Y	Total Accession Numbers with Object(s) Missing:
									=N	Total Accession Numbers with Object(s) Damaged:

Figure 4.3c. Inventory of Museum Property, Accessions Summary (Form 10-349C)

RANDOM ACCESSION INVENTORY OF MUSEUM PROPERTY

TOTAL AIP ACCESSION NUMBERS:

SUMMARY OF FIELDS IN AIP GENERATED DATABASE

YES NO

ACCESSION NUMBER IN USE:

RECORD FOUND:

NOT CATALOGED:

PARTIALLY CATALOGED:

FULLY CATALOGED:

DEACCESSIONED:

OBJECT FOUND:

DAMAGED:

TOTAL AIP ACCESSION NUMBERS WITH OBJECTS(S) MISSING:

TOTAL AIP ACCESSION NUMBERS WITH OBJECTS(S) DAMAGED:

Figure 4.3d. AIP Summary for Random Accessions Inventory [Optional]

NATIONAL PARK SERVICE
OBJECT TEMPORARY REMOVAL SLIP

Catalog Number: PARK 7621
Permanent Location: DINING RM WEST WALL
Purpose for Removal: OUTGOING LOAN
Temporary Location: CONSERVATION ASSOCIATES
Removed By: BRADLEY, JULIA
Date Removed: 07/31/2000

NPS Form 10-97
7/84

Figure 4.4. Object Temporary Removal Slip (Form 10-97)

UNITED STATES DEPARTMENT OF THE INTERIOR REPORT OF SURVEY					Page _____ of _____
					Report No.
					Date
A. Originating Office and Telephone No. (include area code)			Accountable Office and Location		
The following items are: (check one) <input type="checkbox"/> Lost <input type="checkbox"/> Stolen			A statement of circumstances involving the identified property is attached.		
<input type="checkbox"/> Damaged <input type="checkbox"/> Destroyed <input type="checkbox"/> Other (specify)					
			Signature of Accountable Officer:		Date:
ITEM NO.	QUANTITY OR PROPERTY ID NO.	ITEM DESCRIPTION	ORIGINAL ACQUISITION COST (OAC)	CONDITION CODE (See Reverse)	ESTIMATED VALUE
B. To the best of my knowledge the attached statement(s) of circumstances are correct.					
Signature of Cognizant Employee:			Date:	Signature of Custodial Officer:	
				Date:	
C. Board of Survey findings and determinations: A complete statement of Board findings and determinations is attached.			Signature of Board Chairperson:		Date:
Signature of Board Member:			Date:	Signature of Board Member:	
				Date:	
D. Reviewing Authority: <input type="checkbox"/> Approved <input type="checkbox"/> Returned for technical insufficiency (statement attached)			Signature:		Date:
<input type="checkbox"/> Disagree with Board of Survey Findings and Determinations (statement attached)					
E. Head of Bureau or Office: (required only for disagreement between Board and Reviewing Authority) Statement of resolution:			Signature:		Date:
F. CERTIFICATE OF DISPOSITION/DESTRUCTION					
I certify that the item(s) No. _____ listed above have been destroyed, abandoned, or disposed of as directed by a Board of Survey.					
Official Responsible for Disposition/Destruction:			Title:	Signature:	Date:
Witness Name (for Destruction only):			Title:	Signature:	Date:
G. Adjustment to property records (Property Official Signature):		Date Completed	Financial Official Signature (if Required):		Date Completed

Figure 4.5. Report of Survey (DI-103)

U.S. Department of the Interior
National Park Service
COLLECTIONS MANAGEMENT REPORT

Fiscal Year: _____
Park: _____
Center: _____

I. TOTAL COLLECTION SUMMARY FROM PREVIOUS YEAR

	Archaeology	Ethnology	History	Archives	Biology	Paleontology	Geology	Total
A. Objects Cataloged								
B. Catalog Backlog								
C. Total Collection								

II. COLLECTION SUMMARY FOR FISCAL YEAR

A. ACCESSIONS

	Gifts	Exchanges	Purchases	Field Collections	Transfers	Incoming Loans	Total
1. Objects Accessed							

	Archaeology	Ethnology	History	Archives	Biology	Paleontology	Geology	Total
2. Objects Accessed								

B. DEACCESSIONS

	Exchanges	Transfers	Losses	Gifts	Loan Return	NACPRRA
1. Obj Deaccessioned						

	Conveyance	Involuntary Destruction	Voluntary Destruction	Return to Right Owner	Destructive Analysis	Total
1. Obj Deaccessioned (continued)						

	Archaeology	Ethnology	History	Archives	Biology	Paleontology	Geology	Total
2. Obj Deaccessioned								

C. CATALOGING

	Archaeology	Ethnology	History	Archives	Biology	Paleontology	Geology	Total
1. Objects Cataloged								

D. USE OF COLLECTIONS

1. Total Number of Outgoing Loans	2. Total Number of Objects in Outgoing Loans	3. Total Objects in Exhibits	4. Total Number of Research Requests within Park	5. Total Number of Research Requests from Outside Park

III. TOTAL COLLECTION SUMMARY FOR ALL YEARS

	Archaeology	Ethnology	History	Archives	Biology	Paleontology	Geology	Total
A. Objects Cataloged								
B. Catalog Backlog								
C. Total Collection								

IV. NOTEWORTHY ACCESSIONS, DEACCESSIONS, & OTHER (Attach a separate sheet if necessary)

V. FORM COMPLETION INFORMATION

Form Completed By: _____
(Name) (Title) (Phone) (Date)

Approval: _____
(Superintendent for Park Reports, Manager for Center or Repository Reports) Form 10-94 (Rev. 2/98)

Figure 4.6. Collections Management Report (Form 10-94 Rev.)

William Morris, Appraiser
American Society of Appraisers
263 Market Street
Philadelphia, PA 19097

June 7, 1999

Re: Report for Virginia Carter Smith National Historic Site
Ipswich, MA

The following is a list of museum objects that I inspected at your site on June 3, 1999. I have carefully examined each item, and, in my judgement their current replacement values are as follows.

Furniture

English Mahogany Secretary Bookcase, bracket feet, 3 long drawers below 3 short drawers, fitted interior with satinwood fronts, two glass bookcase doors with V-shaped glass divisions, arched cornice, Circa 1790 – 44”w x 93”h \$15,000.00

Mahogany Hepplewhite style Flip Top Dining Table, reproduction, 60” x 36” 1,000.00

Pair of French Walnut Regency style Round Tables, marble top, shelf below, 36” dia. Circa 1900 2,500.00

Sterling Silver

Stuffing Spoon, feather edge, Old English Pattern – Beaver Crest Hallmarked – London 1810 500.00

Pair of Salt Spoons, Fiddle Pattern, Hallmarked London 1810 250.00

Total value: \$19,250.00

The foregoing appraisal is made with the understanding that the appraiser assumes no liability with respect to any action that may be taken on the basis of this appraisal.

The appraiser hereby certifies that he has no interest, present, past or contemplated, in the subject property, and that his fee for this appraisal is not contingent upon the values certified.

Yours very truly,

William Morris
Attachment: Appraiser Qualifications Vita
Comparison Notes on value

Figure 4.7. Written Appraisal Sample

Chapter 5: Outgoing Loans

	<u>Page</u>
A. Overview	5:1
Why does the National Park Service make outgoing loans?	5:1
Who must follow this chapter?	5:1
B. General Information on Loans	5:1
For what purposes may I lend museum objects?	5:1
How long may I lend museum objects?	5:1
To whom may I lend museum objects?	5:2
Must I catalog objects before lending them?	5:2
Who makes the loan?	5:2
How do I document a loan?	5:3
C. Outgoing Loan Considerations	5:3
May I make third-party loans?	5:3
Are there special procedures for loans between parks?	5:3
Do I need a special agreement for loans to non-NPS repositories?	5:4
Must I inventory objects on outgoing loan?	5:4
Are objects on loan subject to NPS collections management policies?	5:4
Where do I get the forms for making outgoing loans?	5:4
What are some things to consider before making a loan?	5:5
Are there special requirements for loaning threatened and endangered species?	5:5
Must I require insurance for outgoing loans to U.S. Government agencies?	5:5
Should I require non-federal borrowers to insure the objects in an outgoing loan?	5:6
Should I require non-NPS conservators to have insurance?	5:6
D. Documenting Loans	5:6
Loan Requests and Consultations	5:6
Facility Reports	5:6
Condition Reports and Photographs	5:7
ANCS+ Loans Out Associated Module	5:7
Loan Number	5:7
Loan Agreement	5:7
Attachments to the Loan Agreement	5:8
Signing the Loan Agreement	5:9
Loan Folder or Accession Folder	5:9
Additional Documentation	5:10
E. Processing Loans	5:10
Insurance	5:10
Packing	5:10
Shipping	5:11
Receipt for Property	5:11
F. Tracking Loans	5:11
Loans in ANCS+	5:11
Monitoring and Recall	5:12
Extensions	5:12
Loan Termination	5:12
G. Special Procedures for Lending Objects to Repositories	5:13
Park Responsibilities	5:13
Repository Responsibilities	5:14

BASIC REQUIREMENTS FOR NPS OUTGOING LOANS

Outgoing loans must further the NPS mission of preservation, education, and research.

You may loan objects to:

- educational, cultural, or scientific institutions
- service-providing organizations, such as conservation labs or exhibit preparation firms
- NPS centers and non-NPS repositories for collections management

Loans to private individuals are prohibited.

Make sure that the borrower can insure, secure, and transport loaned objects properly.

All loans must have a specific termination date. Limit repository loans to 10 years with a renewal option. Limit all other loans to 3 years or less.

Enter all loans into ANCS+. Print the loan forms from ANCS+.

Record condition for all objects in a loan. Recording object condition for loans to repositories is optional.

Complete an Outgoing Loan Agreement, Form 10-127 Rev. for all loans, and attach the Conditions for Outgoing Loans, Form 10-127a.

The superintendent must approve all loans and sign the loan agreement.

Store all loan documents in an optional loan folder or the accession folder.

Track loans by ending date or loan extension date.

CHAPTER 5: OUTGOING LOANS

A. Overview

1. *Why does the National Park Service make outgoing loans?*

Outgoing loans of museum collections further the National Park Service (NPS) mission of preservation, education, and research. Parks also make outgoing loans to repositories for the purposes of long-term collections management and storage. Outgoing loans give borrowers temporary custody, not title.

2. *Who must follow this chapter?*

The staff person responsible for the museum collection must follow this chapter when loaning museum objects. These procedures ensure that the collections are appropriately managed and that the NPS and the borrower are legally protected.

Refer to Chapter 2, Accessioning, in this handbook for procedures on incoming loans.

B. General Information on Loans

1. *For what purposes may I lend museum objects?*

You may lend objects from the park museum collection for purposes such as

- exhibition
- research
- scientific or exhibit preparation
- analysis
- photography
- conservation or other requested services
- long-term collections management and storage

2. *How long may I lend museum objects?*

<i>If you are lending...</i>	<i>Limit the loan to...</i>
to NPS and non-NPS repositories	10 years
to any other institution or organization	3 years

All loans must have a specific termination date. If a borrower requests an extension, you may grant it if you follow Section F.3 in this chapter.

Repository loans remain at the designated repository until you ask for them back, but you must renew them every ten years. The repository must return the loan if it is unable to meet the terms of the agreement.

3. *To whom may I lend museum objects?*

You may lend museum objects to several different types of recipients:

- educational, cultural, or scientific institutions (for example, NPS park museums, non-NPS museums, historical societies, universities, research institutions, and other organizations)
- service-providing organizations (for example, NPS and non-NPS conservation and analytical laboratories or exhibit preparation firms or contractors providing these services)
- NPS centers for collections management (including cataloging and storage)
- non-NPS repositories for collections management (including cataloging and storage)
- other NPS divisions, offices, and units

You may not lend museum objects to private individuals.

4. *Must I catalog objects before lending them?*

Catalog the following objects before you lend them:

- objects lent for exhibit or exhibit preparation
- objects lent for research or analysis (if you don't catalog them, at least document them adequately—for example, in a field specimen log)
- objects lent for photography or conservation (if items need conservation treatment for identification purposes, document these objects adequately—for example, in a field specimen log)
- objects lent to repositories, unless the purpose of the loan includes cataloging

5. *Who makes the loan?*

As the staff person responsible for the museum collection, you must review all potential loans and make recommendations to the superintendent.

The superintendent approves or disapproves all loans.

Once the superintendent approves the loan, you make all arrangements.

Consult the regional/support office (SO) curator before making loans to repositories. Some regions may have a regional mandate to send archeological or natural history collections to a specific repository.

For loans to non-NPS repositories, send an informational copy of the loan agreement to the regional/SO curator.

6. *How do I document a loan?*

You must use the Outgoing Loan Agreement, Form 10-127 Rev. (Figure 5.3) to document loans. Attach the Conditions for Outgoing Loans, Form 10-127a (Figure 5.4) to the agreement. The outgoing loan agreement is a formal, legal agreement that transfers custody for a specific period of time. This agreement protects both parties by specifying the conditions of the loan.

Refer to Section D in this chapter for more information on the outgoing loan agreement.

C. Outgoing Loan Considerations

1. *May I make third-party loans?*

No. The NPS doesn't permit third party loans. You may lend only the objects the museum owns.

Your superintendent may grant NPS repositories blanket approval to make third party loans for routine conservation or research. Note this authority in the additional loan conditions section of the loan agreement.

Your superintendent may grant NPS conservation treatment facilities the authority to initiate third party loans for contract conservation treatment. Note this authority in the additional loan conditions section of the loan agreement.

2. *Are there special procedures for loans between parks?*

Your park as the lender must follow the outgoing loan procedures in this chapter.

If your park is the borrower:

- treat the loan as an incoming loan
- use the lending park's outgoing loan agreement in place of an incoming loan agreement
- follow all other incoming documentation procedures as outlined in Chapter 2 of this handbook
- place the accession number assigned to the incoming loan on the lender's outgoing loan form

3. *Do I need a special agreement for loans to non-NPS repositories?*

No. Use the Outgoing Loan Agreement, Form 10-127 Rev. (Figure 5.3) to cover the objects on loan to the non-NPS repository.

<i>If...</i>	<i>Then...</i>
you are paying the repository for collections management services,	in addition to the loan agreement, you'll need a contract for the services.
the park will have a substantial involvement in the collections management activities, such as park staff on site assisting the repository,	you may need to have a cooperative agreement.

Refer to Director's Order #20: Agreements for information on cooperative agreements.

4. *Must I inventory objects on outgoing loan?*

Yes. Objects on loan are subject to NPS inventory procedures as outlined in Chapter 4. During the first year of a loan, the loan agreement serves as verification for inventory purposes. After the first year, the borrower must make objects available for you to inventory. The borrower may verify in writing or by phone the presence and condition of objects in your inventory.

In addition to inventory, all loans should include a regular monitoring schedule.

5. *Are objects on loan subject to NPS collections management policies?*

Objects on loan remain subject to NPS museum management policies. Federal policies and mandates governing NPS museum collections take precedence over state and local laws and regulations.

Non-NPS repositories must meet National Park Service standards for management of museum collections. These standards are outlined in the *NPS Museum Handbook*, Part I (*MH-I*) and this handbook. Standards for storage of federal archeological objects are outlined in 36 CFR Part 79 "Curation of Federally Owned and Administered Archeological Collections." Systematic collections must remain intact.

Non-federal repositories must give you information each year for the park's Collections Management Report (CMR). Refer to Section VIII of Chapter 4 in this handbook for information on non-federal repositories and the CMR.

6. *Where do I get the forms for making outgoing loans?*

Use ANCS+ to print blank or completed outgoing loan forms. Use acid-free paper to print the forms.

Acid-free paper is available from the Supply and Equipment Program of the Museum Management Program (MMP), National Center for Cultural Resources.

7. *What are some things to consider before making a loan?*

Consider loan requests on a case-by-case basis. Be consistent by setting up written park-specific guidelines for using the collection. Use the following questions to help you determine whether a loan serves the public interest.

- Can the borrower meet the conditions of the outgoing loan agreement?
- Does the loan provide greater public, scholarly, and research access to the park's museum collection?
- Has the borrower asked to handle objects during lectures or demonstrations? The superintendent must approve the request in writing and include any necessary instructions (for example, special handling techniques).
- Is the loan being requested for entertainment or social events (for example, tables used for cocktail parties)? Decline any such request.
- Will you be able to monitor the loan?
- Can the object withstand travel? Does it need any special handling, packing and shipping? If there are questions about an object's stability, get advice from a conservator.
- Is the object one of a kind or otherwise so significant that it should not leave your park?
- Is the object subject to any restrictions that might prevent a loan?
- Have you consulted with affected groups?

8. *Are there special requirements for loaning threatened and endangered species?*

Yes. There are special requirements for loans outside the U.S. You don't need a permit to loan threatened or endangered species across state lines. You do need an export permit to loan threatened or endangered species outside the U.S. Depending on the species, you must contact the Fish and Wildlife Service or the National Marine Fisheries Service for a permit. You'll also need to get an import permit to cover the loan return.

For information on permits, contact:

Fish and Wildlife Service
Office of Management Authority
4401 North Fairfax Drive
Room 430
Arlington, VA 22203
800-358-2104

9. *Must I require insurance for outgoing loans to U.S. Government agencies?*

No. Waive the insurance requirement for outgoing loans to U.S. Government agencies and bureaus (other than the Smithsonian Institution). The U.S. Government is self-insured. The Smithsonian Institution will insure your objects on their insurance policy.

To cover any loss to the park, add the following statement under Additional Loan Conditions on the loan agreement:

"The borrower is responsible for any damage or loss and must reimburse the National Park Service for the cost of conservation, replacement, or reduction in value."

10. *Should I require non-federal borrowers to insure the objects in an outgoing loan?*

Insurance is negotiable. You should require insurance for most outgoing loans. The borrower should give you a certificate of insurance that names the park as an additional insured.

You are responsible for updating the value of the objects on loan, if necessary, for insurance purposes.

11. *Should I require non-NPS conservators to have insurance?*

Many conservators carry insurance. As part of the contract, you can require conservators to cover the cost of insurance while an object is in their care.

D. Documenting Loans

You are responsible for documenting the loan transaction to ensure accountability for the objects. You, as the lender, must maintain all the original documentation.

For an overall view of the loan process, refer to Flow Chart Figure 5.1.

1. *Loan Requests and Consultations*

Loans are requested and arranged in advance. You may send a sample loan agreement and conditions to a potential borrower.

If a NPS repository provides you with written procedures for loans, follow them.

If your park has a collections advisory committee, have it review the potential loan. You may also want to consult with the regional/SO curator before negotiating a loan.

2. *Facility Reports*

You must be sure that a borrower can adequately care for the loan. You may request the borrowing institution to provide written evidence that it can insure, secure, and transport loaned objects properly. You may ask for a facility report before approval of a loan. A facility report allows you to determine the risk of lending an object. A facility report is advisable for loans of controlled property or other sensitive material. The Registrar's Committee of the American Association of Museums publishes a standard facility report. You may get a copy from the MMP, National Center for Cultural Resources.

Waive facility reports for NPS repositories and NPS conservation-treatment facilities.

As part of the loan, you may require non-NPS repositories to complete the NPS Checklist for Preservation and Protection of Museum Collections. Use a paper copy of the Checklist not the automated version. Don't enter the data in ANCS+.

You can print a blank copy of the Checklist from ANCS+.

3. *Condition Reports and Photographs*

You may want to complete an object condition report to document an object's condition before you lend it. Send a copy of this report to the borrower and use it on return of the object to check its condition. The Object Condition Report, Form 10-637 (Figure 5.6) in this chapter is *optional*. You may report condition on Form 10-637 or a park-specific document.

Note: ANCS+ will complete part of Form 10-637 using the condition data from the catalog record. Refer to Chapter 5 in the *ANCS+ User Manual* for information on which fields map to the form.

If you don't use an object condition report, note each object's condition on the list of objects that you attach to the loan agreement.

You don't need to do an object condition report for loans to repositories.

You should photograph all objects you lend except for loans to repositories.

4. *ANCS+ Loans Out Associated Module*

Enter the loan in the ANCS+ Loans Out associated module. This module allows you to track the loan, print all loan forms, and attach loan information to the catalog records. Refer to Section IV in Chapter 4 of the *ANCS+ User Manual* for information on using the module. Use of this module is essential for keeping your annual Collections Management Report (CMR) accurate.

5. *Loan Number*

Give each loan a number and put that number on every loan document. A loan number has three parts:

- L (indicates outgoing loan)
- calendar year (four digits indicating the calendar year, such as 1995)
- outgoing loan transaction number (sequential transaction number within the calendar year, such as 12 for the twelfth outgoing loan transaction in the calendar year)

For example, L.1995.2 means the second loan made in calendar year 1995.

6. *Loan Agreement*

Loan Agreement

You must complete an Outgoing Loan Agreement, Form 10-127 Rev. (Figure 5.3), for all outgoing loans. You cannot substitute a non-NPS form for Form 10-127. The loan agreement includes:

- a detailed list of objects in the loan
- the purpose for the loan
- starting and ending dates
- the addresses and contact names for both parties

- a credit line
- your responsibilities and the borrower's
- conditions of physical care
- shipping and handling information
- insurance information
- specific conditions concerning the loan

You can print a completed outgoing loan agreement from ANCS+. Print two copies of the agreement on acid-free paper.

Your superintendent and the borrower must agree to the loan conditions and sign the form before the loan occurs. Some institutions have incoming loan forms that the superintendent must sign. In the case of conflict between the two forms, the lender's form (Form 10-127 Rev.) controls.

See Figure 5.2 for instructions on completing and sending the outgoing loan agreement.

As a service to your park, an NPS repository may prepare the loan agreement for your superintendent to sign.

7. *Attachments to the Loan Agreement*

Attach a list of objects and the conditions for the loan to the loan agreement.

List of Objects

For loans involving several objects, attach a List of Objects, Form 10-417 (Figure 5.5) to the loan agreement. You may create a park-specific document to use in place of Form 10-417. The list, which serves as an inventory of objects on loan, should include:

- catalog number
- accession number
- item count or quantity
- object name
- description
- condition
- value (if appropriate)
- space for comment

For loans to repositories, you may use a field or laboratory inventory instead of a list of objects. You don't have to include value for loans to repositories.

Note: You can print a completed List of Objects, Form 10-417 (Figure 5.5) from ANCS+.

Conditions

Attach the Conditions for Outgoing Loans, Form 10-127a (Figure 5.4) to the loan agreement or cooperative agreement. If additional conditions are necessary, note them in the additional loan conditions section of the outgoing loan agreement. Additional conditions include requirements such as special restrictions on light levels.

8. *Signing the Loan Agreement*

The superintendent and the borrowing official are responsible for meeting the terms of the loan agreement.

Your superintendent signs two copies of the loan agreement and sends them (with attachments) to the borrower. The borrower signs both copies, returns one copy to the park, and keeps the other copy.

For loans to repositories, the repository chief or institution director must sign the loan agreement.

For loans to non-NPS repositories, send an informational copy of the loan agreement to the regional/SO curator.

9. *Loan Folder or Accession Folder*

Store all documents generated by the loan in an acid-free, straight (full) tab cut folder, or in an accession folder. Whatever folder you choose, use it consistently. Refer to Chapter 2 in this handbook for information on the accession folder.

Outgoing Loan Folder

- Store all original documents associated with a loan in this folder. Mark the loan number in the upper left corner of the folder and the termination date in the upper right corner of the folder.
- Insert the optional Outgoing Loan Folder Cover Sheet, Form 10-640 (Figure 5.7). Print this form from ANCS+ on acid-free paper.
- File the folder by loan number or termination date.
- Store the folder in a separate, marked section of your accession filing cabinet.
- Copies of the loan agreement may be added to the catalog or accession folder.
- Keep the folder and contents after the loan ends.

Accession Folder

- File all original paperwork for the loan in the accession folder.
- If multiple accessions are involved, file the original paperwork in the accession folder of the lowest accession number.

File copies of the loan agreement in each subsequent accession folder.

10. *Additional Documentation*

Update the Object Status, Status Date, and Location fields in ANCS+ to show what objects are on loan.

Complete a temporary removal slip for all objects on loan, except for repository loans. Place the removal slip in the object location noted on the ANCS+ catalog record.

Note: Your annual CMR includes the number of outgoing loans and the number of items on loan.

E. Processing Loans

You are responsible for processing the loan. This may include:

- arranging for conservation work (you may arrange with the borrower to cover conservation costs)
- making sure that objects are safe for travel
- making sure that there is insurance coverage, if required
- coordinating packing and shipping arrangements
- completing any additional paperwork

The borrower is responsible for loan-related expenses, unless otherwise arranged in advance. If the loan is for the benefit of the park, such as a loan for conservation or photography, the park pays the cost.

1. *Insurance*

See that non-NPS borrowers get their own insurance coverage. They should give you a certificate of insurance that names the park as an additional insured, unless you waive the insurance requirement.

Insurance requirements are waived for all loans to NPS parks, NPS repositories, and NPS conservation facilities.

Refer to Section VII in Chapter 4 of this handbook for information about insurance policies.

2. *Packing*

Make sure that all objects are packed securely and adequately. Use professional packing and shipping companies if you lack the training, facilities, or materials to pack museum objects.

Pack and label containers according to the *MH-I*, Chapter 6. If non-NPS staff do the packing, oversee the work. The borrower should keep the

original packing materials, if possible. The borrower packs the objects for return in the same way they arrived or improves the packing.

Enclose an inventory of objects and a return address in each container. Include the catalog number and condition of each object or enclose condition reports. Also include any special instructions for unpacking and repacking. Under separate cover send a copy of the inventory.

Unless otherwise noted on the loan agreement, you pack the objects and provide the packing materials for loans to repositories and NPS conservation facilities.

3. *Shipping*

Don't ship the objects until you have a signed loan agreement from the borrower.

The borrower arranges the shipping with your approval and pays all shipping costs. You may arrange for shipping and charge shipping costs to the borrower.

A shipping list is useful to the borrower and the shipping company. Don't put monetary values or historical information on shipping lists. You may use the postal system to mail certain objects that are sturdy and within the specified size limits. Use certified or registered mail with a return receipt requested. Don't use the postal system for items of high intrinsic or monetary value.

Unless otherwise agreed to in writing, you are responsible for shipping costs and the safe transportation of museum objects to repositories and NPS conservation facilities.

Refer to the *MH-I*, Chapter 6: Handling, Packing and Shipping Museum Objects.

4. *Receipt for Property*

Send a Receipt for Property (DI-105) to the borrower under separate cover. The borrower signs the receipt and returns one copy to you.

A memo or electronic mail message may also be used to acknowledge receipt of objects.

F. **Tracking Loans**

You are responsible for tracking all outgoing loans. Keep up-to-date loan agreements for all outgoing loans.

1. *Loans in ANCS+*

Use ANCS+ to track your loans by return date. ANCS+ has all the required fields for loan data and allows you to sort your loan data by return date.

Refer to Section IV of Chapter 4 in the *ANCS+ User Manual* for information on using the Loans Out associated module.

2. *Monitoring and Recall*

Track loans by date to ensure that you get objects back on time.

Reserve the right to inspect the objects on loan at any time. All loans should include a regular monitoring schedule.

You may end a loan with 30 days notice to the borrower. You may end a loan without notice if an object is at risk.

The borrower must give at least 30 days written notice to cancel a loan before the termination date.

3. *Extensions*

Tell the borrower when a loan is coming due. If the borrower requests a loan extension, review it and make a recommendation to the superintendent. All loan extensions require the superintendent's approval.

Give an extension a specific ending date, not to exceed three years. Loans to repositories may be extended for up to ten years per extension.

You may ask the borrower to update the standard facility report when negotiating a loan extension.

The borrower must extend insurance coverage, if applicable. The borrower gives you a copy of the certificate of insurance for the extension period. The certificate of insurance must name the lending park as an additional insured.

Prepare the loan extension documents. Use either:

- the optional Outgoing Loan Extension, Form 10-641 (Figure 5.8)
- a memorandum to extend the loan
- a new loan agreement, using the same loan number

Note: You can print a completed Outgoing Loan Extension, Form 10-641 from ANCS+. Print two copies of the extension form on acid-free paper.

If a memorandum is used, it must include the same information and signatures as the loan extension form. Keep the original loan number but update other data.

The borrower should sign and return the extension document at least thirty days before the original termination date.

The superintendent signs the extension document upon its return and sends a copy to the borrower. Keep a copy with the loan documentation.

4. *Loan Termination*

If the borrower returns part of a loan before the ending date, note the return date on the outgoing loan agreement or in the comment column on the list of objects. Continue to track partially returned loans until you have all objects back. Keep the original loan number for tracking purposes.

The loan transaction is complete when all objects in the loan have come

back to you. Examine the objects for any change in condition upon return of the loan. Contact the borrower immediately if there are problems. Record any changes in condition on the Object Condition Report Form 10-637 (Figure 5.6) and the catalog record. Change the location and object status on the catalog records.

Your superintendent signs the loan agreement acknowledging receipt of all objects. You then send a copy to the borrower. The original stays in your park.

G. Special Procedures for Lending Objects to Repositories

1. *Park Responsibilities*

Loans to repositories are made to manage collections or store them. Consult with the regional/SO curator before sending objects to a NPS center or non-NPS repository. The superintendent should send a written request asking the center or repository to accept the collection as an incoming loan. The center or repository should respond in writing.

In addition to the loan agreement, send the following with the objects you lend to a repository:

Inventories

For cataloged objects, provide an inventory or computer-generated list that includes catalog numbers, item quantification, object name, description, condition, and value (if appropriate).

For uncataloged objects, include field or laboratory-level inventories, or both, provided by the investigator. Produce an updated inventory when cataloging is completed. Include field specimen numbers, NPS catalog numbers, item quantification, object name, description, condition, and value (if appropriate).

Documentation

Accession all objects in the loan.

Provide copies of all appropriate documentation in the accession file, catalog folder, and any supplemental database. Keep all original documentation on ownership.

Include all associated records, such as field and lab records, maps, and photos, as defined in Appendix D of this handbook.

Conservation

Include a list of known conservation problems (for example, rust, mold, weak repairs). Supply copies of object treatment reports or conservation surveys for any prior conservation treatment.

2. *Repository Responsibilities*

If the repository is to catalog the objects, it must use ANCS+ or an export format compatible with ANCS+. The repository must give the park electronic copies of catalog records. Optional paper copies of catalog records can be printed at the National Catalog, Harpers Ferry, WV.

The repository must place any information added to a natural history specimen label on a new label. The old label is kept with the specimen.

A complete inventory and all associated original documents must accompany returned loans.

H. **Special Procedures for Lending Objects to NPS Conservation Treatment Facilities**

1. *Request for Treatment or Analysis*

You can make a request to a NPS conservation facility by e-mail, phone, or letter. You no longer need to use the Object Treatment Request (OTR). Complete the loan agreement after the facility has reviewed and accepted your request.

2. *Exhibit Plans*

Exhibit projects often include many objects requiring treatment, mounting, or other exhibit preparation. You and/or the conservator prepare a list of objects for conservation, mounting, or other exhibit preparation. This list may be used in place of the List of Objects, Form 10-417 (Figure 5.5).

You may send the objects in batches to the conservation treatment facility over time. You and/or the conservator determine whether objects can withstand shipment. Use a single loan agreement to cover all the shipments needed for an entire exhibit. Document each shipment to and from the treatment facility with a receipt for property.

3. *Documentation*

Provide the facility with paper or electronic copies of catalog records for the objects.

The NPS conservation facility provides you with copies of all reports of examination and treatment.

I. LIST OF FIGURES

- | | |
|------------------|---|
| Figure 5.1 | Flow Chart for Outgoing Loans |
| Figure 5.2 | Instructions for Completing and Sending the Outgoing Loan Agreement |
| +* Figure 5.3a-b | Outgoing Loan Agreement (Form 10-127 Rev.) |
| +* Figure 5.4a-b | Conditions for Outgoing Loans (Form 10-127a) |
| + Figure 5.5 | List of Objects (Form 10-417) [Optional] |
| + Figure 5.6 | Object Condition Report (Form 10-637) [Optional] |
| + Figure 5.7 | Outgoing Loan Folder Cover Sheet (Form 10-640) [Optional] |
| Figure 5.8 | Outgoing Loan Extension (Form 10-641) [Optional] |
- + Print these forms from ANCS+.
- * You must use the Outgoing Loan Agreement (Form 10-127 Rev.) and the Conditions for Outgoing Loans (Form 10-127a) for all outgoing loans.

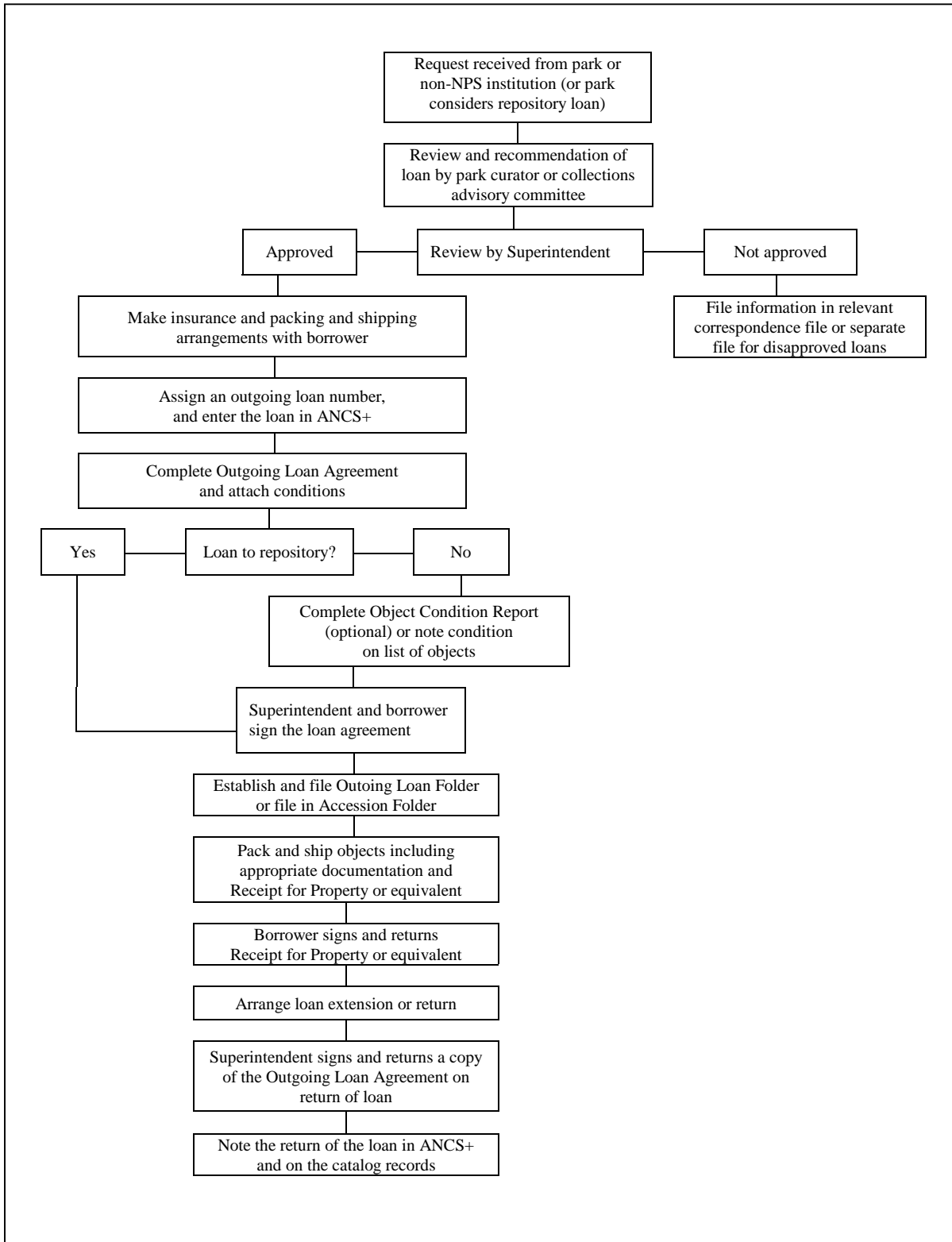

Figure 5.1. Flow Chart for Outgoing Loans

INSTRUCTIONS FOR OUTGOING LOAN AGREEMENT

Outgoing Loan Number	Enter the outgoing loan number. Example: L.1993.12. L (outgoing loan indicator), calendar year (four digits indicating the calendar year), outgoing loan transaction number (sequential transaction number within the calendar year).
Lender	Enter the name of the park.
Lender Address	Enter the park's street/box, city, state, zip code, telephone number, and FAX number.
Lender Shipping Address	Enter the shipping address of the park, if it is different from the mailing address.
Superintendent (Lending Park)	Enter the name of the superintendent or center chief, for authorization and contact purposes.
Borrower (Institution)	Enter the name of the institution that is borrowing the material (for example, University of Arizona). Indicate whether it is a NPS unit or a non-NPS institution.
Borrower (Department)	Enter the department or division of the borrowing institution (for example, Department of Anthropology), where applicable.
Borrower Address	Enter the borrower's street/box, city, state, zip code, country (if outside USA), telephone number and FAX number.
Borrower Shipping Address	Enter the shipping address of the borrower, if it is different from the mailing address.
Responsible Official (Borrowing Institution)	Enter the name and title of the responsible individual [or agent] of the borrowing institution (for example, G. A. Lindsay, Director).
Purpose of Loan	Indicate the purpose of the loan (exhibit, study, conservation, exhibit preparation, collections management, storage, or other). If other, explain.
Credit Line	Record the credit line as it is to appear in exhibit graphics, publications, or other media.
Objects in Loan	List the objects in the loan. Include the catalog number, accession number, object name, item count or quantification, description, condition, and insurance value (if appropriate). For loans involving several objects, attach the List of Objects (Form 10-417) or a computer-generated list.
Initiation Date	Record the date on which the agreement is to go into effect.
Termination Date	Enter the termination date of the loan. Loans to repositories cannot exceed ten years. All other loans cannot exceed three years.
Insurance	Indicate whether the insurance will be waived or carried by the borrower. Enter the name of the insurance company and the policy number. Indicate if the certificate of insurance or waiver of subrogation has been received. Refer to Chapter 4 of this handbook for information on insurance.
Packing and Shipping	Indicate who will be responsible for packing the objects. Provide information on the method of shipping for sending and returning the loan. If a shipping company is used, include the name, address, and phone number. Indicate who will be responsible for shipping charges.
Loan Conditions	Indicate whether a facilities report is required. Include any other additional conditions. Attach a copy of the Conditions for Outgoing Loans (Form 10-127a).
Signature and Date Lines	Enter the name of the superintendent and the borrowing official. Both parties must sign and date the agreement. The repository chief or institution director must sign the agreement for repository loans.
Return Status (Partial or Complete)	Indicate whether the entire loan has been returned. If part of the loan has been returned, enter date of return for each object returned.
Extension Information	For extended loans, enter the new termination date.
Return Signature	Enter the name of the superintendent. The superintendent must sign and date the agreement when the entire loan is returned.
Sending and Returning the Loan Agreement	The superintendent signs two copies of the loan agreement and sends them to the borrower. The borrower signs and returns one copy to the park and keeps the other signed copy. The park does not release the objects until the signed agreement is received. On return of the entire loan, the superintendent signs and dates the original agreement and sends a copy to the borrower.

Figure. 5.2. Instructions for Completing and Sending the Outgoing Loan Agreement

US Department of the Interior
National Park Service

Outgoing Loan Agreement

Outgoing Loan No.**NPS Unit (Lender):**

(Street/Box)

Telephone:

(City/State/Zip)

Fax Number:

Superintendent (please print):

Shipping Address (if different):

BORROWING INSTITUTION (Borrower):

(Department)

Telephone:

(Street/Box)

Fax Number:

(City, State, Zip, Country)

Title:

Responsible Official (Borrower):

Shipping Address (if different):

NPS Status:

PURPOSE OF LOAN:

Credit Line:

OBJECTS IN LOAN:

INITIATION DATE**TERMINATION DATE:**

INSURANCE AND SHIPPING/PACKING:

Insurance Paid By:

Insurance Company:

Policy No.:

Packer:

Shipping Paid By:

Method of Shipping: Outgoing:

Return:

Form 10-127 Rev.
February 1998

Figure 5.3a. Outgoing Loan Agreement (Form 10-127 Rev.)

US Department of the Interior
National Park Service

Outgoing Loan Number

Outgoing Loan Agreement (Continued)

LOAN CONDITIONS:

Outgoing loans are subject to the same terms and conditions noted on the attached Conditions for Outgoing Loans.

Additional Loan Conditions:

SIGNATURES:

ON INITIATION OF THIS AGREEMENT: The undersigned borrower is an authorized agent of the borrowing institution. Signature indicates agreement to terms specified in this loan agreement and attached conditions.

PLEASE SIGN BOTH COPIES AND RETURN ORIGINAL TO THE NPS.

Name of Responsible Official (Borrowing Institution), Title (Please print)

Signature

Date

Name of Superintendent (Lending NPS Unit) (Please print)

Signature

Date

RETURN STATUS:

Extension Termination Date:

RETURN OF LOAN:

The undersigned is an authorized agent of the lender. Signature acknowledges receipt of all material in good condition or in condition as noted on this agreement or in attached object condition report(s). A signed copy is sent to the borrower to acknowledge the return of the loan.

Name of Superintendent (Lending NPS Unit) (Please print)

Signature

Date

Figure 5.3b. Outgoing Loan Agreement (Continued) (Form 10-127 Rev.)

Conditions For Outgoing Loans

GENERAL

1. It is the Borrower's responsibility to become familiar with stipulations covering this transaction. Responsibility for meeting the terms agreed to in this loan agreement remains with the borrowing institution and authorized agent.
2. No loans will be made until all necessary documentation has been received by the lending park, and the Outgoing Loan Agreement has been signed by both parties.
3. The borrowing institution is not permitted to make third party loans. Such loan requests shall be treated as an independent outgoing loan and negotiated between the lending park and the second borrowing institution. Unless specifically agreed to in writing on the attached loan agreement, the borrowing institution is not permitted to make third party loans. Such loan requests shall be treated as an independent outgoing loan and negotiated between the lending park and the second borrowing institution.
4. Borrower agrees to incur all expenses relating to this loan unless otherwise noted.
5. Borrower agrees not to use the loaned museum objects/specimens/archival items (henceforth "loaned items") for commercial or other revenue-generating purposes without the prior written authorization of NPS.
6. If the loaned items are to be exhibited, cited, or illustrated in a publication, or otherwise made public, the credit line must cite the following elements and conform to any additional specifications in the loan agreement: "National Park Service," park name, control number (such as a catalog or negative number), object/specimen name, and original creator (if applicable, e.g. artist name). The NPS is not responsible for the quality of exhibits, publications, or interpretive or educational programs that may feature NPS loaned items.
7. The Borrower shall provide to Lender a copy, at no cost, of any publication or report featuring the loaned items.
8. The Borrower, in the event of a change of address, shall provide the NPS with written notification thereof within 15 days of such change.
9. Federal laws and policies governing NPS museum collections take precedence over state and local laws.
10. The borrower agrees to care for loaned items in a manner consistent with NPS policies and procedures as stated in *Director's Order #24: NPS Museum Collections Management* and in *NPS Museum Handbook* (<http://www.nps.gov/policy/DOOrders/DOOrder24.html>) (<http://www.cr.nps.gov/museum/publications/index.htm>).

COPYRIGHT AND PHOTOGRAPHY RESTRICTIONS

1. Loaned items are subject to restrictions outlined in the copyright law of the United States (Title 17, U.S. Code). Borrower will honor copyright restrictions as they apply to the loaned items and will ensure that the appropriate copyright releases are obtained.
2. Unless otherwise agreed to in writing, no reproductions are permitted by the Borrower except photographic copies for condition reports, documentation, damage, educational, and publicity purposes related to the stated purpose of this loan.

INSURANCE

1. All loaned items shall be continuously and fully insured at the Borrower's expense for the amount specified on the loan agreement, unless waived and so noted on the agreement. Insurance shall be wall-to-wall, and provide coverage against all risks of physical loss or damage from any external causes while in transit and on location for the entire duration of the loan. Borrower shall provide proof of insurance to the lending park. The NPS must be notified in writing at least 20 days prior to any cancellation or meaningful change in the Borrower's insurance policy. If additional coverage is taken by the Borrower, the lending park must receive from the Borrower a copy of the certificate of insurance naming the lending park as an additional insured.
2. Any lapses in coverage or any failure to secure insurance and/or any inactions by the Lender regarding notice will not release the Borrower from liability for loss or damage.
3. Dollar values provided are confidential and are for insurance purposes only. The NPS reserves the right to increase the amount of insurance coverage required on the loaned items, if reasonably justified.
4. If insurance is waived, the Borrower agrees to indemnify any and all loss or damage to the loaned items occurring during the course of the loan, except for loss or damage resulting from inherent vice, war, and nuclear incident.
5. Borrower agrees to waive all claims and recourse against the NPS for loss or damage to persons, museum collections, or loaned items arising from this agreement. Borrower agrees to defend, indemnify, and save harmless the NPS from all liability, loss, cost, or obligation on account or arising out of any injury to any person or property of any kind, from any cause whatsoever, in any way connected with Borrower's use of said property, including acceptance and redelivery thereof.

CONDITION, ALTERATION, AND CONSERVATION

1. Each loaned item is considered to be in good condition unless otherwise noted.
2. Loaned items may not be cleaned, repaired, retouched or altered in any way without the express permission of the Lender.
3. Loss, damage or deterioration must be reported to the lending park. If damage occurs, NPS staff will arrange any necessary conservation treatment. The Borrower or its insurance company is liable for all costs resulting from damage, including the cost of conservation, and for any reduction in value or replacement.

HANDLING AND CARE

1. All physical care (e.g., handling, storage, exhibition) should meet or exceed the standards set down in the *NPS Museum Handbook*, Part I.
2. Loss or damage, whether in transit or on the borrower's premises, and regardless of who may be responsible, must be reported immediately. Photographs and documents of the damage (e.g., condition report) with dates, names, and other details of the occurrence (e.g., damage reports) must be sent to the lending park within 5 working days of the loss or damage.

NPS Form 10-127a
January 2006

Figure 5.4a. Conditions for Outgoing Loans (Form 10-127a)

Conditions For Outgoing Loans (Continued)

3. The Borrower and all users of the loaned items have received the U.S. Department of the Interior (DOI) Notice of Potential Hazard in Museum Collections (DI-3320). If the Borrower provides access to the loaned items to users other than those identified in this loan agreement, the Borrower is responsible for providing this DOI notification to the users and returning acknowledgement of notification to the Lender.

SECURITY AND ENVIRONMENTAL CONTROLS

1. Borrower must provide, at all times, adequate security in order to protect loaned items against risk of damage, loss or deterioration due to theft, vandalism, fire, smoke, and water. Adequate protection against insects, vermin, fungi, mold and pollutants must be provided. Conditions should comply with museum standards and the NPS *Museum Handbook*, Part I.
2. Loaned items must be protected, at all times, against damage caused by exposure to direct sunlight, ultraviolet light, excessive humidity, or proximity to heating or cooling sources. Temperature and relative humidity levels should be monitored on a daily basis. Levels are controlled to minimize short-term fluctuations and to avoid harmful extremes. Conditions should comply with museum standards and the NPS *Museum Handbook*, Part I.
3. If these conditions cannot be met, the lending park must be advised in writing. The amended conditions should be attached to the loan agreement and noted in the additional conditions on the face of the attached agreement prior to the completion of the agreement.

PACKING AND SHIPPING

1. Packing and transportation must be by safe methods designated and approved in advance by the Lender and noted on the attached agreement. Borrower must comply with shipping and packing instructions provided by the Lender.
2. Lender will pack the loaned items and will provide packing materials for the loan. If required by the terms of the agreement, the Borrower will pay for packing materials.
3. Unpacking and repacking must be done by experienced personnel under competent supervision. The loan must be repacked in the same manner as received and with the same packing materials, if possible, unless otherwise mutually agreed upon by Lender and Borrower. All packing materials should be stored, if possible, during the loan period in a place fully conditioned to the same temperature and relative humidity as those under which the loan itself is stored or displayed. All packing materials that are to be reused must be protected from contamination by insects, mold, dust, airborne pollutants, and other sources.

ACCESS

1. Access to loaned items by individuals for purposes other than those identified on the attached agreement must receive prior approval by the Lender and must be supervised by the Borrower. Borrower agrees to provide access to loaned items only when all other options, such as photographs or reproductions, have been exhausted. Use of loaned items must be restricted to a supervised area. Researchers will be subject to the Lender's current user rules and restrictions. Borrower will be responsible for any misconduct by persons "using" loaned items.
2. Borrower must provide access to Lender's staff or representatives during regular hours of operations for the purposes of inspections, inventory, repacking, research and condition reporting.

3. Borrower is subject to NPS annual inventory procedures as noted in the NPS *Museum Handbook*, Part II. Either the Borrower will confirm Lender's inventory or will provide access to the Lender to conduct an inventory, as noted in the special conditions on the agreement.

REPOSITORY LOANS

1. Loans for storage and collections management ("repository" loans) may not exceed 20 years, renewable.
2. Items loaned to a repository for the purposes of collections management and/or storage will be cataloged according to the NPS *Museum Handbook*, Part II, and in accordance with requirements established by the lending park. Copies of all catalog records and electronic data will be sent to the lending park by the borrowing repository.
3. The Borrower will either respond to the Lender's requests for information about loaned items for the purposes of completing an annual inventory, or, if approved in advance by the Lender, include the loaned items in the Borrower's annual inventory of its collections and report on the results of the inventory to the Lender. Borrower's inventory must be equivalent to the inventory required by NPS *Director's Order #24*.
4. Unless specifically exempted in this Agreement, the Borrower will complete a Collections Management Report and the Checklist for Preservation and Protection of Museum collections as specified in NPS *Director's Order #24*.
5. Repository loans must remain at the designated repository until they are requested by the lending park or until such time as the repository is unable to care for the loan in accordance with the loan stipulations. The loan may be terminated by either party, by giving 3 months notice, or within 30 days if the lending park determines the loan stipulations are not being met. Should the Borrower be unable to continue care for the loaned items, the items must be returned to the lending NPS park or another designated repository approved by the Lender.
6. The conditions specific to repository loans take precedence when in conflict with other conditions in this Agreement. Otherwise, all conditions apply to repository loans.

EXTENSION AND RECALL

1. Any extensions of the loan period must be requested by the Borrower. The Lender will prepare extension documents to be completed and signed by the Borrower and received by the Lender at least 30 calendar days prior to the original loan expiration date shown on the attached agreement. All additional insurance will be extended by the Borrower and proof of insurance will be provided to the Lender by a copy of the certificate of insurance naming the NPS Lender as an additional insured and dated with the new termination date of the loan.
2. The Lender reserves the right to inspect or audit the loaned items at any time. Should the Lender desire to recall any of the loaned items for its own purposes, it may do so by giving at least 30 days notice to the Borrower. Loaned items may be withdrawn by the Lender without prior written notice to the Borrower if it is determined that they are receiving improper care.
3. Borrower agrees to give at least 30 days written notice to the Lender if electing to cancel this loan prior to the term of this loan agreement.

Figure 5.4b. Conditions for Outgoing Loans (Continued) (Form 10-127a)

US Department of the Interior
National Park Service

Page _____ of _____

LIST OF OBJECTS

Park Acronym _____
Number _____

CATALOG NUMBER	ACCESSION NUMBER	ITEM COUNT OR QUANTITY	OBJECT NAME	DESCRIPTION AND CONDITION	VALUE	COMMENT

NPS Form 10-417
July 1995

Figure 5.5. List of Objects (Form 10-417) [Optional]

Object Condition Report

DOCUMENTATION:

Catalog Number: _____ Accession Number: _____
Object Name: _____ Item Count: _____
Component Parts (list): _____ Outgoing Loan Number: _____
Photograph Numbers: _____

CONDITION:

Describe structural and surface condition (e.g. tears, losses, cracks, chips, holes, foxing, abrasion, scratches, tape residues, mold, buckling, discoloration, stains, flakes, patina), and any other conditions, and note location:

CONDITION DESCRIBED BY:

Name (Please print) Title (Please print)

Signature Date

CONDITION ON RETURN OF OBJECT: Same as above Other (describe): _____

CONDITION DESCRIBED BY:

Name (Please print) Title (Please print)

Signature Date

Figure 5.6. Object Condition Report (Form 10-637) [Optional]

Termination Date _____

Outgoing Loan Number _____
 Park Name _____

OUTGOING LOAN FOLDER COVER SHEET

INSTRUCTIONS: This Outgoing Loan Folder Cover Sheet may be used whenever a park lends museum collections to other parks, repositories, or non-NPS institutions. Insert this in the outgoing loan folder.

<p>A. TYPE OF LOAN</p> <p>B. BORROWER</p> <p>C. PURPOSE</p> <p>Initiation Date _____ Termination Date _____ Extension Date _____</p>	<p>D. OUTGOING LOAN AGREEMENT DOCUMENTATION IN THIS FOLDER</p> <ul style="list-style-type: none"> <input type="checkbox"/> Outgoing Loan Agreement and List of Objects <input type="checkbox"/> Correspondence relating to outgoing loan <input type="checkbox"/> Insurance documents <input type="checkbox"/> Shipping documents <input type="checkbox"/> Packing documents <input type="checkbox"/> Conservation records <input type="checkbox"/> Restriction records relating to outgoing loan <input type="checkbox"/> Photographs <input type="checkbox"/> Facility Report <input type="checkbox"/> Other (Specify): _____ <input type="checkbox"/> Loan extension request and documents
---	---

E. RETURN OF OUTGOING LOAN

- Loan Returned
- Partial (date): _____
- Complete (date): _____
- Comments

Figure 5.7. Outgoing Loan Folder Cover Sheet (Form 10-640) [Optional]

Outgoing Loan Extension

Outgoing Loan No.

NPS Unit (Lender):

(Street/Box)

Telephone:

(City/State/Zip)

Fax Number:

BORROWING INSTITUTION (Borrower):

(Department)

(Street/Box)

Telephone:

(City, State, Zip,

Country)

Fax Number:

Responsible Official (Borrower):

Title:

LOAN DATES:

Original initiation date of loan agreement:

Original termination date of loan agreement:

Length of extension requested:

OBJECTS IN LOAN:

EXTENSION REQUEST:

Borrower requests permission to extend the duration of the Outgoing Loan Agreement.

Extension Requested by:

Signature of Responsible Official (Borrowing Institution)

Date

EXTENSION APPROVED OR DENIED:

Length of Extension granted:

Extended termination date:

Extension granted by:

Signature of Superintendent (Lending NPS Unit)

Date

Extension not granted. Provide explanation:

PREVIOUS EXTENSIONS AND COMMENTS:

Previous Extensions:

Additional Conditions/Comments:

Figure 5.8. Outgoing Loan Extension (Form 10-641) [Optional]

Chapter 6: Deaccessioning

	<u>Page</u>
A. Overview	6:1
What is deaccessioning?	6:1
Who must follow this chapter?	6:1
B. General Information on Deaccessions	6:1
What is the best deaccession policy?	6:1
What laws grant deaccessioning authority to the NPS?	6:1
What types of deaccessions are permitted?	6:2
What does the term “conveyance” mean?	6:3
Who determines which objects to deaccession?	6:3
Must I convert previous deaccessions to the new system in this chapter?	6:3
Where do I get the forms for deaccessioning?	6:3
Must I follow these procedures to deaccession all types of museum material?	6:3
C. Special Considerations for Deaccessions	6:3
May I deaccession hazardous objects or substances in a museum collection?	6:3
Should the park tell a donor about a deaccession?	6:4
Must I catalog objects before deaccessioning them?	6:4
What are some things to consider before deaccessioning museum objects?	6:4
May I reuse accession or catalog numbers from deaccessioned objects?	6:4
What can I do about non-museum property that has been accessioned into the museum collection by mistake?	6:5
May I accession objects expressly to use them in an exchange?	6:6
Do I deaccession nitrate negatives that have been reformatted?	6:6
D. Processing Deaccessions	6:7
Deaccession Requests	6:7
Consultation with the Regional/SO Curator	6:7
Deaccession Package	6:7
Collections Advisory Committee	6:8
Collections Advisory Committee Members	6:8
Collections Advisory Committee Procedures	6:9
Approval or Disapproval	6:10
E. Documenting Deaccessions	6:10
ANCS+ Deaccessions Associated Module	6:10
Catalog Data	6:11
Photographs	6:11
Justification	6:11
Informal Appraisals	6:11
Formal Appraisals	6:12
Appraisers	6:13
Deaccession Form	6:13
List of Objects	6:14
Legal Disposition Document	6:14
F. Tracking Deaccessions	6:15
Filing Disapproved Deaccession Documentation	6:15
Deaccession Number	6:15
Filing Approved Deaccession Documentation	6:15
Deaccession Book or Log System	6:16
Updating the Museum Records	6:17
G. Packing and Shipping Deaccessions	6:17
Packing	6:17

Shipping	6:18
Receipt for Property	6:18
H. Return to Rightful Owner (See Flow Chart Figure 6.1)	6:18
When would I return objects to the rightful owner?	6:18
What are the procedures for returning objects to the rightful owner?	6:18
I. Loss, Theft, Involuntary Destruction, Voluntary Destruction/Abandonment (See Flow Chart Figure 6.2).....	6:19
What is loss, theft, or involuntary destruction?.....	6:19
What is voluntary destruction or abandonment?.....	6:19
What should I do when I discover a loss?	6:19
Where can I find Board of Survey Procedures?.....	6:20
Can the Board of Survey disapprove a deaccession?	6:20
What do I do with approved Board of Survey actions?	6:20
What if an object is recovered after being deaccessioned?	6:20
How do I update the museum records for recovered objects?.....	6:20
When can I use voluntary destruction or abandonment to deaccession an object?.....	6:21
Does the collections advisory committee review deaccessions that involve voluntary destruction or abandonment?.....	6:21
Are there special procedures for deaccessioning hazardous materials?.....	6:22
Are there special procedures for deaccessioning by abandonment?.....	6:22
J. Outside Scope of Collection (See Flow Charts Figures 6.3 and 6.4)	6:22
What types of objects are outside the park's Scope of Collections Statement (SOCS)?	6:22
How can I deaccession objects that are outside my park's SOCS?.....	6:23
Can I deaccession archeology collections as outside the park's SOCS?	6:23
May I deaccession archeological collections that include NAGPRA material?	6:23
May I deaccession archeology collections from land that has been deauthorized?	6:23
Can I deaccession natural history collections as outside the park's SOCS?	6:23
May I deaccession natural history collections from land that has been deauthorized?	6:24
What do I need to know about title and restriction verifications?.....	6:24
What is a transfer?.....	6:24
What is an exchange?	6:24
What is a conveyance (donation)?	6:25
K. Outside SOCS Requirements	6:25
What are the special requirements for deaccessions outside the park's SOCS?	6:25
What is the order of preference for deaccessioning objects that are outside a park's SOCS?.....	6:25
Why is there an order of preference for deaccessions?	6:26
What if there is more than one potential recipient?.....	6:26
How do I evaluate a potential recipient's qualifications?.....	6:26
Can a park ever deaccession objects out of the order of preference?.....	6:26
How do I determine whether other parks need the objects?	6:26
When must I publicly advertise a deaccession?	6:27
Where must I place the public notice?	6:27
What must I include in the public notice?.....	6:27
What happens after the notice has been on the WWW for forty-five days?	6:28
L. Outside SOCS Procedures	6:28
How do I find non-NPS recipients?.....	6:28
How do I document a transfer?	6:29
What are some special considerations for exchanges?	6:29
Can an exchange be unequal in monetary value?.....	6:29
How do I document an exchange?.....	6:30
What documents do I attach to the exchange agreement?.....	6:30
When do I post a World Wide Web notice of intent to exchange?.....	6:30
How do I document a conveyance (donation)?.....	6:30

	When do I post a World Wide Web notice of intent to convey (donate)?	6:30
	When can I use voluntary destruction or abandonment to deaccession museum objects?	6:31
	What are some special considerations for voluntary destruction or abandonment?	6:31
	How do I document voluntary destruction or abandonment?	6:31
M.	Destructive Analysis	6:32
	When do I deaccession objects under the destructive analysis category?	6:32
	Who approves destructive analysis?	6:32
	How do I document destructive analysis?	6:32
	Where can I find information on destructive analysis?	6:32
N.	Native American Graves Protection and Repatriation Act (See Flow Chart Figure 6.5)	6:32
	What types of items are subject to NAGPRA?	6:32
	Who can request repatriation?	6:33
	How do I respond to requests for summary items?	6:33
	How do I respond to requests for inventory items?	6:33
	Who does the regional/SO curator consult about repatriations?	6:34
	What do I include in the deaccession package?	6:34
	What does the superintendent do with the deaccession package?	6:34
	What happens to disapproved requests?	6:35
	What happens to approved requests?	6:35
	What is the Federal Register notice?	6:35
	Are there time limits for responding to a repatriation request?	6:36
	What documentation should I give to the recipient?	6:36
O.	NPS Clearinghouse Services	6:37
	Can the NPS Clearinghouse help parks with deaccessions?	6:37
	How does the NPS Clearinghouse advertise objects for deaccession?	6:37
	How do I send information to the Clearinghouse newsletter?	6:37
	May I post information about potential deaccessions on the Curatorial Bulletin Board?	6:37
	How do I publish notices on the Clearinghouse World Wide Web listing?	6:38
P.	List of Figures	6:38

BASIC REQUIREMENTS FOR NPS DEACCESSIONS

Deaccession museum collections only under the following categories using the appropriate disposition documents that appear after each category.

- return to rightful owner (other than return of an incoming loan) – letter and Receipt for Property
- loss, theft, damage or involuntary destruction – Report of Survey
- voluntary destruction/abandonment – Report of Survey, Witness Statement
- outside Scope of Collection by transfer, exchange, conveyance (donation) or voluntary destruction/abandonment – Transfer of Property, Exchange Agreement, Conveyance (Donation) Agreement, Report of Survey
- destructive analysis – Memorandum of request
- NAGPRA compliance – Repatriation Agreement

Read the appropriate section of this chapter for the type of deaccession you are documenting. There are special requirements that you should be aware of for each deaccession type.

Get formal appraisals for all exchanges outside the DOI.

Place a 45-day public notice on the World Wide Web at <http://www.cr.nps.gov/csd> for all exchanges outside the federal government and all conveyances (donations).

Catalog all objects into ANCS+ before deaccessioning them.

Enter all deaccessions into ANCS+. Print the deaccession forms from ANCS+.

Complete a Deaccession Form (Form 10-643) for all deaccessions. Prepare a deaccession package for each deaccession. Include a justification for the deaccession, catalog records, a legal disposition document, and other documentation related to the deaccession.

A collections advisory committee must review all deaccessions outside the DOI and all deaccessions involving voluntary destruction or abandonment.

The superintendent must approve all deaccessions and sign all disposition documents.

Assign a deaccession number to each deaccession transaction.

Track deaccessions in the accession book or an optional deaccession book.

Store deaccession records in the accession folder or an optional deaccession folder.

Don't delete accession and catalog records for deaccessioned objects. Don't reuse these numbers.

CHAPTER 6: DEACCESSIONING

A. Overview

1. *What is deaccessioning?* Deaccessioning is the process of permanently removing National Park Service (NPS) museum collections from a NPS unit's ownership (title) and custody. It should be a rare action. This chapter discusses the types of deaccessions that the NPS permits and explains NPS deaccessioning procedures.
2. *Who must follow this chapter?* The staff person responsible for a NPS museum collection must follow this chapter to deaccession museum objects. These procedures ensure that NPS deaccession actions:
 - meet the highest professional, legal, and ethical standards for accountability of museum collections
 - withstand close public scrutiny
 - maintain the public's trust
 - protect park personnel or their relatives from allegations of unethical conduct, partiality, or conflict of interest

Procedures for returning incoming loans are excluded from this chapter. Refer to Chapter 2, Accessioning, in this handbook for procedures on the return of incoming loans.

B. General Information on Deaccessions

1. *What is the best deaccession policy?* The best *deaccession* policy is a good *accession* policy. NPS museum procedures require you to accession only objects that are appropriate to the park's scope of collection. Refer to the NPS *Museum Handbook*, Part I (*MH-I*), Chapter 2, Scope of Museum Collections, for guidance on writing a Scope of Collection Statement (SOCS). By setting up a good accession policy, you can avoid lengthy or potentially questionable deaccessions.
2. *What laws grant deaccessioning authority to the NPS?* Two laws specifically authorize NPS deaccessions:
 - Museum Act of 1955, P.L. 84-127, 69 Stat. 242 (codified as amended at 16 U.S.C. §§ 18f to 18f-3 [Supp.1997]).
 - Native American Graves Protection and Repatriation Act (NAGPRA), P.L. 101-601 (1990), (codified at 25 U.S.C. §§ 3001-3013 [Supp. 1997]).

Note: Refer to Appendix A in this handbook for the Museum Act of 1955, as amended.

3. *What types of deaccessions are permitted?*

The NPS is authorized by law to deaccession museum collections under these categories:

- return to rightful owner (other than return of an incoming loan)
- loss, theft, damage or involuntary destruction
- voluntary destruction/abandonment
- outside Scope of Collection by:
 - transfer to other NPS units
 - transfer of museum collections outside a park's SOCS and no longer needed for NPS museum purposes to qualified federal agencies dedicated to the preservation and interpretation of natural or cultural heritage and qualified to manage museum collections, including the Smithsonian Institution
 - exchange by accepting museum objects, museum collections, and other personal properties, and by granting in exchange museum property that is no longer needed or that may be held in duplicate, such exchanges to be made on a basis that is equitable and in the public interest, to:
 - other NPS units (two transfers is a simpler method)
 - other qualified federal agencies
 - non-federal governmental entities
 - private institutions and individuals
 - conveyance (donation) of museum collections outside the park's SOCS and no longer needed for NPS museum purposes to:
 - private institutions exempt from federal taxation under section 501(c)(3) of the Internal Revenue Code of 1986, dedicated to the preservation and interpretation of natural or cultural heritage, and qualified to manage museum collections
 - non-federal governmental entities, providing the recipients are dedicated to the preservation and interpretation of natural or cultural heritage and qualified to manage museum collections
 - voluntary destruction/abandonment of museum collections that have been determined to have no scientific, cultural, historic, educational, esthetic, or monetary value
- destructive analysis
- compliance with NAGPRA

You may deaccession museum collections by transfer, exchange, conveyance (donation), voluntary destruction, or destructive analysis only if the NPS owns the objects (clear title) and there are no restrictions on such an action in the documents transferring title to the NPS.

4. *What does the term “conveyance” mean?*

For NPS purposes, a conveyance is a donation, since the NPS can't receive money for museum objects. You only convey objects to entities outside the federal government.

5. *Who determines which objects to deaccession?*

As the staff person responsible for the museum collection, you must propose all potential deaccessions and recommend action to the superintendent.

The superintendent must set up a collections advisory committee to review all exchanges outside the Department of the Interior (DOI), transfers to non-DOI federal agencies, conveyances (donations), and voluntary destruction/abandonment.

The superintendent approves or disapproves all deaccessions.

Note: In accordance with 41 CFR-101-45.902-2, the regional director, or other authorized reviewing official who is not directly accountable for the property, must approve abandonment.

6. *Must I convert previous deaccessions to the new system in this chapter?*

No. You may convert previous deaccessions to the new system described in this chapter, but conversion is not required.

7. *Where do I get the forms for deaccessioning?*

Use ANCS+ to print blank or completed deaccession forms. Use acid-free paper to print the forms.

Acid-free paper is available from the Supply and Equipment Program of the Museum Management Program (MMP), National Center for Cultural Resources.

8. *Must I follow these procedures to deaccession all types of museum material?*

Yes. The law requires you to treat museum collections “in a careful and deliberate manner that protects the public interest.” Refer to Section C.6 for information on removing non-museum property from the collection.

Refer to Section IV of Chapter 4 in this handbook for information on deaccessioning reproductions.

C. Special Considerations for Deaccessions

1. *May I deaccession hazardous objects or substances in a museum collection?*

Yes. Refer to the *MH-I*, Chapter 11, Curatorial Health and Safety Issues, Section D, for procedures on hazards in the collection. Follow the Report of Survey procedures in Section I of this chapter to deaccession these materials.

Nitrate negatives in Stages 3-5 of deterioration are hazardous materials. Deaccession them and dispose of them as an immediate threat through your hazardous materials coordinator. Refer to the MH-I, Appendix M: Nitrate and Cellulose Ester Film, for information on nitrate negatives.

2. *Should the park tell a donor about a deaccession?*
- Although not legally required, it is a good practice to tell the source of accession (donor) or known heirs before starting a deaccession action. Because of potential tax liabilities defined by the Internal Revenue Service, you should not accession museum objects with the intent to deaccession them later.
- Refer to Section C.7 of this chapter for information on tax liabilities.
3. *Must I catalog objects before deaccessioning them?*
- Yes. You must catalog all objects proposed for deaccessioning. You must enter pre-Automated National Catalog System (ANCS+) manual catalog records into ANCS+ before deaccessioning them. Complete the registration data for objects that you deaccession due to loss, theft, or involuntary destruction (unless full catalog information is available).
4. *What are some things to consider before deaccessioning museum objects?*
- Deaccession actions must:***
- be consistent with relevant laws, and with current DOI and NPS policies
 - consider the need to safeguard the federal government against loss of the scientific, associational, evidential, artifactual, informational and/or monetary value represented by the objects
 - avoid real or apparent conflict of interest. Refer to 5 CFR 2635 and the related supplement, “Employee Responsibilities and Conduct” (43 CFR Part 20). Refer to the most current codes of ethics for curators and registrars published by the American Association of Museums.
 - be supported by the catalog data and written justification
- Deaccession actions should:***
- keep the objects in public ownership whenever possible
 - take into consideration any community requests for objects to stay in the museum, city or area, such as a local museum
 - avoid the perception that the museum is deaccessioning objects in exchange for objects of lesser importance
 - avoid the perception that the action is being made in accordance with current fads or fashions (for example, furniture of a certain period is no longer in high demand and so is deaccessioned)
 - preserve the integrity of systematic collections
- NPS employees and their relatives must not:***
- acquire deaccessioned museum collections (or financial interest therein)
 - appear to benefit personally in any way from a deaccession action and subsequent disposition
5. *May I reuse accession or catalog numbers from deaccessioned objects?*
- No. Never reuse accession or catalog numbers from deaccessions. These numbers are permanently assigned to the objects in the deaccession.

6. *What can I do about non-museum property that has been accessioned into the museum collection by mistake?*

You must evaluate mistaken accessions on a case by case basis. Errors do occur, but you must correct them as appropriate to the circumstances. Seek the professional, written opinion of the members of the collections advisory committee. See Sections D.4 – D.6.

The mistakenly accessioned property must not fit the definition of museum property as defined in the glossary of the Cultural Resource Management Guideline.

Some examples of mistakenly accessioned non-museum property may include exhibit cases, exhibit mounts, and library books (except historic books such as those in Frederick Douglass’s library).

Don’t use the formal deaccessioning procedures in this chapter to deaccession non-museum property that has been accessioned in error. You don’t need to catalog this material. Instead, use the following procedures:

- recommend the deaccession to the superintendent with a written justification that includes the documented opinions of the members of the collections advisory committee
- have the superintendent sign a document authorizing the transaction

For example, if you recommend transferring exhibit cases to the facility manager, the superintendent signs a transfer of property.

Document the action as follows in order to “close the books” on the mistaken accession:

- place a memo explaining the action and supporting opinions in the accession file and catalog folder, if one exists
- write “Accessioned in Error” in the remarks column of the accession book and sign and date the entry (as appropriate, enter catalog numbers)
- change the object status on the catalog record in ANCS+ to “Removed Non-Museum Property”
- note the mistake in the description field and the disposition in the location field on the catalog record, if a catalog record exists

Don’t reuse the accession or catalog numbers.

7. *May I accession objects expressly to use them in an exchange?*

No. The NPS items used in an exchange must be outside the SOCS. A park may not acquire objects outside the SOCS. In addition, acquiring objects to use in an exchange gives the impression that the park is dealing in collections. There are also potential tax liabilities in doing this with donations.

Tax liabilities may relate to the:

- use to which a gift was put
- donor's intent in making the gift and knowledge about its use

<i>If the park...</i>	<i>Then...</i>
deaccessions donated objects within two years of the donation	the park must report the transaction to the Internal Revenue Service along with the donor's tax identification number on Form 8282, Donee Information Return
deaccessions donated objects more than two years after the donation	the donor still may be subject to penalties, but the park doesn't report the action to the Internal Revenue Service

With the superintendent's approval, a third party, such as the park's cooperating association, could assist the park with acquiring objects. For example, the association could acquire an object and exchange it for an object that the park wants. The association could then donate the object it acquired through the exchange to the park.

Note: The tax liabilities described above also apply to third party transactions.

8. *Do I deaccession nitrate negatives that have been reformatted?*

No. Don't deaccession nitrate negatives that have been reformatted.

You can destroy nitrate negatives at Stages 1-2 of deterioration if:

- the negatives have only informational or administrative value, *and*
- you have a high quality copy that has been inspected to current standards

Destruction of reformatted nitrate negatives is not a deaccession. Although you are destroying the negative, you still have the image, which will have the same accession and catalog number as the negative.

Refer to the *MH-I*, Appendix M, for information on nitrate negatives.

D. Processing Deaccessions

1. *Deaccession Requests*

You are responsible for processing deaccessions. The deaccession procedures outlined in this section are the same for all types of deaccessions. Actions specific to each deaccession type appear in Sections H-N.

You receive requests to deaccession items in the case of:

- return to rightful owner
- destructive analysis
- repatriation (NAGPRA)

You begin the deaccession process in the case of:

- loss, theft, damage or involuntary destruction
- objects outside the Scope of Collection Statement
- voluntary destruction/abandonment

2. *Consultation with the Regional/SO Curator*

Consultation with the regional/support office (SO) curator is recommended, but not required, for all deaccessions.

The regional/SO curator may consult with appropriate discipline specialists and recommend actions to you regarding the deaccession.

You should consult with the regional/SO curator about all NAGPRA requests.

3. *Deaccession Package*

For each proposed deaccession, prepare a deaccession package that includes all the documentation described in Section E. Prepare one deaccession package for each deaccession type and recipient. The package includes the following documentation:

- Deaccession Form, Form 10-643 (Figure 6.6)
- List of Objects, Form 10-417 (Figure 6.7) or equivalent
- justification for the deaccession (including documentation that the objects have been advertised throughout the NPS, if required)
- justification for disposition out of the order of preference (see Section K.2), if applicable
- catalog records and photographs
- appraisals (if required)
- legal disposition document

ANCS+ will print the deaccession form, list of objects, catalog records, and most disposition documents.

Forward the package to the superintendent for approval or disapproval (see Section C.7). The superintendent will forward the package to the collections advisory committee (see Sections C.4-C.6) for review. Some deaccessions require the committee's review, but the superintendent may choose to use the committee for all deaccessions.

4. Collections Advisory Committee

The superintendent must set up a collections advisory committee to review all deaccessions involving:

- transfer to another federal agency outside the DOI including the Smithsonian Institution
- conveyance (donation) to a private institution or non-federal governmental entity, as defined in section B.3
- exchange outside DOI (excluding exchange of natural history specimens)
- voluntary destruction/abandonment of museum objects

Note: The superintendent also may use the members of the collections advisory committee to review potential acquisitions. The committee may review other issues related to the museum collection, such as consumptive use requests.

The collections advisory committee reviews the appropriateness of the deaccession and its disposition. The law requires a systematic review that meets the highest standards of the museum profession. More importantly, a review committee composed of impartial and disinterested individuals provides for checks and balances. It protects the superintendent and park staff from possible accusations of partiality, self-dealing, or vested interest.

5. Collections Advisory Committee Members

The committee must include at least two members. One member must be a curator at or above the GS-11 level. The other members of the committee may not be under the supervision of the curator. If the park doesn't have a curator at or above the GS-11 level, the park must appoint a curator from another park or the support office.

Note: The members of the committee must be federal employees due to Federal Advisory Committee Act (FACA) considerations (41 CFR §§ 101-6.1004). On a case by case basis, the superintendent can request a non-federal specialist to review a deaccession transaction. The superintendent may ask the specialist to record his or her comments and recommendations on a specialist review form (Fig. 6:15), but the non-federal specialist cannot serve on the committee.

There is no maximum number of members for the committee. A committee

of three to five members is recommended. Possible sources for members are staff from the park, regional or support office, NPS cultural preservation and archeological centers, Denver Service Center, Harpers Ferry Center, other parks, and other government agencies. It is advisable to have one or more members from outside the park. Committee members should be chosen from the following list of specialists:

curator (a minimum of one at GS-11 or above)
archeologist
archives technician
archivist
biologist
conservator
cultural resource specialist
ethnographer
geologist
historical architect
historical landscape architect
historian
interpreter
museum specialist
museum technician
natural resource specialist
paleontologist

Note: Some parks may choose to use the members from their Section 106 (National Historic Preservation Act) review committee for the collections advisory committee.

The person responsible for the museum collection advises the superintendent as to which members of the committee should review a particular deaccession. A minimum of two members must review and make recommendations on a deaccession. The superintendent notifies committee members who are to review a particular deaccession and appoints a lead committee member. Committee members may consult with subject matter specialists who are not on the committee regarding specific actions.

6. *Collections Advisory
Committee Procedures*

The collections advisory committee meets at regular intervals, or as needed. If all the committee members are not at the same location, meetings can be by phone or videoconference.

The committee operates under a documented set of procedures to make sure that all decisions are fair, open, and in the best interests of the public. Each committee member must record his or her comments and document any consultations with other specialists. See Figures 6.14 and 6.15 for a sample set of procedures and a review form.

Committee members may recommend for or against deaccession of all the objects. They may also recommend against deaccession of individual objects, while agreeing with the remainder of the proposal. The lead committee member attaches the comments of the committee members, and any non-federal specialists consulted during the review, to the deaccession package. The committee then returns the package to the superintendent.

7. Approval or Disapproval

The superintendent reviews the deaccession package and approves or disapproves the deaccession and disposition.

<i>If the superintendent...</i>	<i>Then...</i>
approves the deaccession	he or she signs the deaccession form and disposition action
approves or disapproves a deaccession contrary to one or more of the collections advisory committee member's recommendations	he or she must attach an explanation to the deaccession form
disapproves the deaccession	the action stops

The superintendent may approve exchanges outside the federal government and conveyances (donations) but must inform the intended recipient of the 45 day public notice requirement. See Section K.8-K.11.

The superintendent may disapprove deaccessioning individual objects within the package while approving the remaining objects for deaccession. You can remove the disapproved objects from a partially approved package and return the package to the superintendent for approval. You may resubmit a disapproved package when you have addressed the reasons for disapproval.

Note: The regional director, or other authorized reviewing official who is not directly accountable for the property, must approve abandonment. See 41 CFR-101-45.902-2.

E. Documenting Deaccessions

You are responsible for documenting all deaccessions following the procedures in this section. Documentation must be clear, adequately cross-referenced, and permanently maintained by the park. The deaccession documentation in this section is the same for all types of deaccessions. Documentation specific to each deaccession type appears in Sections H-N. Include this documentation in the deaccession package.

1. ANCS+ Deaccessions Associated Module

The Deaccessions associated module in ANCS+ allows you to document and track deaccessions. When you complete the appropriate fields in the program, the program completes and prints all the deaccession forms for you. It also updates the Object Status and Location fields on the catalog records for the deaccessioned objects. Refer to Section VII of Chapter 4 in the *ANCS+ User Manual*. Use of this module is essential for keeping your annual Collections Management Report (CMR) accurate.

2. *Catalog Data*

Catalog all objects proposed for deaccessioning. You must enter pre-ANCS, manual catalog records into ANCS+. Complete both registration and catalog data fields on the Museum Catalog Record (Form 10-254). Complete the registration data for objects that have been lost, stolen, or involuntarily destroyed unless full catalog data are available. Catalog data support the proposed deaccession action and aid in the disposition of the objects. Documentation on the museum catalog record must demonstrate:

- what the object is
- the intrinsic, cultural, and scientific significance of the object
- the monetary value of the object (if the object has no monetary value, list it as \$00.00)

Refer to Sections E.5 and E.6 for information on appraisals.

You must keep catalog records for deaccessioned objects in your ANCS+ database. Don't delete these records. They are part of the paper trail for the deaccession.

3. *Photographs*

Where possible, photograph the object before completing the deaccession transaction. Keep the photograph as part of the permanent record for the object.

Photograph NAGPRA items that are determined to be culturally affiliated in consultation with the receiving party.

4. *Justification*

Concisely, justify in writing each deaccession transaction. The justification must clearly outline the details in support of the proposed action. The written justification for NAGPRA deaccessions must reference the data used to determine the NAGPRA categories.

The written justification for objects leaving the NPS must include documentation to show that:

- the park has advertised the objects throughout the NPS
- no other NPS sites are in need of the objects (or why the park denied NPS requests for the objects)

Note: The law states that you may deaccession objects to non-NPS recipients if the objects are no longer needed for NPS museum purposes. Advertising throughout the NPS is necessary to make sure that other parks don't need the objects for museum purposes.

If you propose a deaccession that is out of the order of preference, you must have a written justification. See Section K.2 for order of preference.

5. *Informal Appraisals*

Museum collections have scientific, associational, evidential, artifactual, informational and/or monetary value. You or outside specialists determine scientific and intrinsic value by examining the object and its documentation. You also must consider the object's association with the total collection. You may make an informal estimate of the monetary value of each NPS

object to be deaccessioned, as appropriate. This may be done by referencing:

- current values on the catalog record
- purchase price or appraisals made at the time of acquisition
- prices of similar objects paid at auctions, or recorded as paid in catalogs, trade journals, and similar publications

Enter the current value on the museum catalog record. Include the value of each object on the list of objects to be deaccessioned, if appropriate.

6. Formal Appraisals

The NPS requires formal appraisals only for exchanges outside the federal government. Get a minimum of one formal, written appraisal (sometimes referred to as “an arms-length appraisal”) for objects below \$20,000 in value. Get two appraisals for objects over \$20,000 in value. You are required to get appraisals for the objects you deaccession as well as those you acquire through an exchange.

Appraisals are recommended, but not required, for:

- transfers to non-DOI federal agencies, including the Smithsonian Institution
- conveyances (donations) to private institutions and non-federal governmental entities, as defined in Section B.3

Use prudent and conservative judgement in deciding whether to appraise objects before deaccessioning. Appraisals are appropriate to all collections for which there is a market. Appraisals are less likely to be needed for certain scientific collections, such as botanical specimens. However, some scientific collections, such as geological and paleontological collections, have a well-established market.

Appraisals are a necessary and accepted museum practice to:

- make sure that the deaccession is credible
- make sure that an exchange is equitable
- maintain the public trust
- avoid any value-related conflict of interest or appearance of conflict of interest

Generally, the NPS unit pays the costs for appraisals.

Enter the current appraisal value on the museum catalog record. Enter the value on the list of objects to be deaccessioned.

A formal appraisal is generally not required for the exchange of natural history specimens. For certain specimens, such as paleontology specimens, an appraisal may be appropriate. Consult the regional/SO curator before exchanging natural history specimens.

7. *Appraisers*

In order to acquire the services of a qualified appraiser, refer to Section IX in Chapter 4 of this handbook. Get lists of appraisers from the regional/SO curator, the NPS Clearinghouse, or curators/archivists of similar collections. Chapter 4 in this handbook has contact information for the American Society of Appraisers.

File copies of appraisals in the appropriate accession folder(s) or the optional deaccession folder.

A qualified appraiser must complete all appraisals.

The appraiser must:

- justify the appraisal in writing and sign the statement
- determine the value objectively
- state in writing that he or she will not acquire title to or interest in, and has no immediate interest in, any of the appraised objects
- avoid any conflict of interest or appearance of conflict of interest. For example, an appraisal by the curator of the collection would have an appearance of conflict of interest. An appraisal by the support office curator involved in the deaccession might have an appearance of conflict of interest.
- have no vested interest in the outcome of the appraisal

8. *Deaccession Form*

You must complete a Deaccession Form, Form 10-643 (Figure 6.6) for each deaccession transaction. The deaccession form includes the following:

- the type of deaccession and disposition
- a detailed list of objects in the deaccession
- a list of attachments to the form
- a brief summary of the deaccession
- your recommendation and signature
- the collections advisory committee's recommendation, if appropriate
- the superintendent's approval and signature

The superintendent must sign the deaccession form showing approval of the deaccession and disposition type.

9. *List of Objects*

For deaccessions involving several objects, attach a List of Objects, Form 10-417 (Figure 6.7) to the deaccession form. You may create a park-specific list to use in place of the List of Objects, Form 10-417. The list, which serves as an inventory of objects in the deaccession, must include:

- catalog number
- accession number
- item count or quantity
- object name
- brief description and condition
- value (if appropriate)
- space for comment

10. *Legal Disposition Document*

The legal disposition document conveys control (possession and title) of a museum object. It must accompany the deaccession form. Disposition documents vary depending upon the type of deaccession transaction. A list of appropriate disposition documents for each deaccession type appears below.

<i>Deaccession Type</i>	<i>Disposition Document</i>
Return to Rightful Owner	Receipt for Property
Loss/Theft/Damage Involuntary Destruction	Report of Survey
Voluntary Destruction/ Abandonment	Report of Survey Witness Statement
Outside Scope of Collection	Exchange Agreement <i>or</i> Transfer of Property <i>or</i> Conveyance (Donation) Agreement
Destructive Analysis	Memorandum of request to superintendent
NAGPRA Compliance	Repatriation Agreement

The superintendent must sign the deaccession form and the appropriate disposition documents. The recipient must sign the receipt for property, exchange agreement, transfer of property, conveyance (donation) agreement, or repatriation agreement.

You should recommend a specific disposition for the object when preparing the deaccession package. However, the superintendent may approve objects for deaccession before a specific disposition has been determined. You must then get separate approval for the disposition.

F. Tracking Deaccessions

You must track all deaccessions following the procedures in this section.

The tracking information outlined in this section is the same for all types of deaccessions.

1. *Filing Disapproved Deaccession Documentation*

File the deaccession package for disapproved deaccessions in the accession folder or in a file folder for deaccession proposals. File disapproved deaccessions by date if placed in a separate file folder. Maintain these files as permanent records.

2. *Deaccession Number*

Give each approved deaccession a number. A deaccession number has two parts separated by a decimal point:

- D (for deaccession)
- deaccession transaction number (sequential transaction number, such as 3 for the third deaccession transaction)

For example, “D.3” means the third deaccession transaction.

Put the deaccession number in the upper right corner of all documents that relate to the deaccession.

Enter the deaccession number in the remarks column of the accession book. The number is a cross-reference to the deaccession package that you filed in the accession or deaccession folder.

3. *Filing Approved Deaccession Documentation*

Permanently maintain the original paperwork for each approved deaccession at the park. This paperwork documents the history of the deaccessioned objects.

File the deaccession package and all associated documentation in the accession folder or an **optional** deaccession folder, described below. Whatever folder you choose, use it consistently. If you anticipate a large number of deaccessions (more than 10 deaccession transactions), use of the optional deaccession folder is recommended. Refer to *MH-II*, Chapter 2 in this handbook for information on the accession folder.

Accession Folder

- File all original paperwork in the accession folder.
- If the deaccession involves multiple accessions, file the original

paperwork in the accession folder of the lowest accession number.

- File archival copies of the deaccession form and disposition document in each subsequent accession folder.

Deaccession Folder (optional)

- Store all original documents associated with the specific deaccession transaction in the folder. Mark the deaccession number in the upper left corner of the folder. Use permanent black ink.
- Insert the optional Deaccession Folder Cover Sheet, Form 10-644 (Figure 6.8).
- File the folder by deaccession number.
- Store the folder in a separate, marked section of your accession filing cabinet.

Note: If you use the deaccession folder, you may also want to place an archival copy of the deaccession form and disposition document in the accession folder.

4. ***Deaccession Book or Log System***

Track deaccessions by using the ANCS+ Deaccessions associated module.

You may also use the **optional** Deaccession Book, Form 10-642 (Figure 6.9) or another form of log system to track deaccessions. The bound deaccession book is a sequential log of all deaccession transactions. Enter the following information for each deaccession:

- deaccession number
- deaccession date (the date the other party signs the disposition document). See Section E.10 for a list of disposition documents.
- brief description of items in the deaccession
- disposition (recipient name and address, for institutions include name of responsible official and department); describe disposition for deaccessions that have no recipient
- deaccession type
- accession and catalog numbers of the items in the deaccession (if there is not enough space, refer to a list in the folder)
- number of items in the deaccession (item count)
- remarks

Procedures for data changes and preservation and storage of the deaccession book are identical to those for the accession book. Refer to *MH-II*, Chapter 2, Accessioning, in this handbook.

Note: You can get deaccession books from the Museum Supply and

Equipment Program.

5. *Updating the Museum Records*

You must update both the electronic and paper accession records and electronic catalog records for all deaccessions.

All catalog records for deaccessioned objects must be in ANCS+.

Accession Records

- Enter the deaccession number in the remarks column of the accession book.
- Note deaccessions in the notes column on the list of objects attached to the accession receiving report.

Catalog Records

- ANCS+ will track the deaccession number automatically and enter “Deaccessioned” in the Location field.
- ANCS+ will enter the appropriate deaccession type in the Object Status field of the catalog record.
- ANCS+ will enter the fiscal year of the deaccession in the Status Year field of the catalog record.
- Change the Controlled Property field on the catalog record to N (no), if needed.
- Send copies of the updated electronic records to the National Catalog along with the annual electronic submission.

Other Documentation

- Note the deaccession on any other pertinent documentation, such as the catalog number log book.

Note: You must report the number of deaccessions for each year on your annual Collections Management Report (CMR).

G. Packing and Shipping Deaccessions

1. *Packing*

You are responsible for packing and shipping all deaccessioned objects.

You must pack all objects securely and adequately to make sure that objects aren't damaged in transit. Use professional packing and shipping companies if you lack the training, facilities, or materials to pack museum objects.

Pack and label containers according to the *MH-I*, Chapter 6, Handling, Packing and Shipping Museum Objects. If non-NPS staff do the packing, oversee the work. Enclose an inventory of objects and a return address in

each container. Include any special instructions for unpacking. Under separate cover send a copy of the inventory.

Before packing, shipping, or delivering NAGPRA items, consult with the receiving tribe or lineal descendant to arrange the return of repatriated items. You are responsible for packing and shipping repatriated items. Pack and ship NAGPRA items following, where possible, the instructions of the receiving tribe or lineal descendant.

2. *Shipping*

Ship the objects only if you have a signed disposition document (transfer of property, exchange agreement, repatriation agreement, conveyance agreement) from the recipient. It is customary for the receiving party to pay all shipping charges, including insurance, unless otherwise agreed to in writing before shipping. The NPS may pay for shipping repatriated items.

A shipping list is useful to the recipient and the shipping company. Don't put monetary values or historical information on shipping lists. You may use the U.S. postal system for objects that are sturdy and within the specified size limits. Use certified or registered mail with a return receipt requested. Don't use the postal system for fragile or highly valuable objects.

3. *Receipt for Property*

Use a receipt for property, or equivalent, with all deaccessions that involve the physical receipt of objects.

Send a Receipt for Property (DI-105) to the recipient under separate cover. The recipient signs the receipt and returns the original copy to you.

You may use a memo or electronic mail message in place of a receipt for property to acknowledge receipt of objects. The memo must provide all the information that is on the receipt for property. Place an acid-free copy of the message in the appropriate file.

H. Return to Rightful Owner (See Flow Chart Figure 6.1)

Refer to Sections D-G for processing, documenting, tracking, and packing and shipping deaccessions.

1. *When would I return objects to the rightful owner?*

On rare occasions, a park museum collection may have an object acquired from previous holders who were not the legal owners. In other cases, you may not have legal documentation of NPS title. You may receive a request to return the object to the rightful owner(s).

2. *What are the procedures for returning objects to the rightful owner?*

All requests for the return of museum objects must be in writing. You should consult with the regional/SO curator when you receive a request for return of a museum object. Document all conversations and actions taken, and file this information in the appropriate folder.

The justification to return an object must include a solicitor's written opinion or court order. The regional/SO curator can help you contact the region's solicitor. The superintendent must sign the correspondence conveying the object to the rightful owner.

The receiving party and the superintendent sign a Receipt for Property (DI-105) to document receipt by the rightful owner. Keep the original receipt for property and the original copy of the solicitor's opinion or court order. File them in the relevant deaccession or accession folder.

I. Loss, Theft, Involuntary Destruction, Voluntary Destruction/ Abandonment (See Flow Chart Figure 6.2)

Refer to Sections D-F for processing, documenting and tracking deaccessions.

1. *What is loss, theft, or involuntary destruction?*

A deaccession because of loss, theft or involuntary destruction involves "unintentional loss." It is not a purposeful deaccession. Objects in this category are:

- stolen and not recovered within 30 days
- consumed or effectively destroyed by fire, flood, or other disaster
- destroyed by biological or chemical factors
- missing and cannot be located within 30 days after a thorough search

Thoroughly review deaccessions in this category and make changes in collection management practices to prevent similar future occurrences.

2. *What is voluntary destruction or abandonment?*

A deaccession involving voluntary destruction or abandonment is an intentional deaccession. Objects in this category are:

- hazardous materials (refer to *MH-I*, Chapter 11, Curatorial Health and Safety and *Loss Control Management Guideline*), or
- involuntarily damaged beyond all treatment and determined to have no scientific, cultural, historic, educational, esthetic, or monetary value

Note: See Section L for information on voluntary destruction/abandonment for objects outside the park's SOCS.

3. *What should I do when I discover a loss?*

Follow the actions outlined in Section III of Chapter 4 in this handbook. A local NPS law enforcement officer will prepare a Case Incident Record (Form 10-343) or equivalent. You must submit a Report of Survey (DI-103) to the superintendent if the object is not found within 30 days.

The report of survey must include:

- a copy of the case incident record or equivalent
- any subsequent reports of investigation
- a photocopy of the catalog record that includes a description of the object
- a photograph of the object, if available

4. *Where can I find Board of Survey Procedures?* Follow the Report of Survey procedures found in:
- 410 DM, Personal Property Management Regulations
 - *Personal Property Management Handbook No. 44*, Section 8
5. *Can the Board of Survey disapprove a deaccession?* Yes. If the superintendent or the Board of Survey disapproves the Report of Survey, the deaccession action stops. The deaccession documentation remains in the accession file or deaccession proposal file as a permanent record. Disapproval may be due to:
- insufficient verification of loss
 - inadequate search
 - disagreement as to the degree of damage
- You may propose the same objects for deaccession at a later date if you give enough justification.
- Note:** The superintendent cannot overturn the findings of a Board of Survey. However, in the case of voluntary destruction/abandonment, the superintendent may decide not to send the action to the Board of Survey. The objects then remain in the collection.
6. *What do I do with approved Board of Survey actions?* You will receive a copy of all reports, findings and recommendations from the Board of Survey. File this documentation in the appropriate accession or deaccession folder and proceed with the deaccession.
7. *What if an object is recovered after being deaccessioned?* Follow these procedures if a stolen or lost object is later returned to the park's possession:
- Document the circumstances of the recovery in the accession and/or deaccession folders.
 - Update all pertinent museum documentation as described in Section I.8 below.
8. *How do I update the museum records for recovered objects?* You are responsible for updating museum records when an object is recovered.
- Deaccession Documents***
- If you recover all the objects in the deaccession, mark the deaccession form and the Report of Survey "Void." Have the superintendent sign and date these documents next to the "Void." In ANCS+, enter "VOID" in the Notes field in the Deaccessions associated module.
 - If only some of the objects were recovered, note which objects were recovered on the list of objects. Don't void the deaccession form or the Report of Survey. In ANCS+, note which objects were recovered in the Notes field in the Deaccessions associated module.

- Note the recovery in the remarks column of the deaccession book, if the park is using one. In ANCS+, note the recovery in the Notes field in the Deaccessions associated module.

Accession Documents

- Note the recovery in the remarks column of the accession book. Note the recovery on the list of objects attached to the accession receiving report.

Catalog Records

- Remove “Deaccessioned” from the Location field on the catalog record.
- Update the Object Status and Status Year fields on the catalog record.
- Add a note about the deaccession and return in the Description field on the catalog record.
- Enter the deaccession number in the Other Numbers field on the catalog record.
- Send electronic copies of the updated catalog records to the National Catalog along with the annual submission.

Other Documentation

- Note the recovery on any other pertinent documentation, such as the catalog number log book.

9. *When can I use voluntary destruction or abandonment to deaccession an object?*

In extremely rare instances, you may request the voluntary destruction or abandonment of an object. Use the Report of Survey procedures described in this section. The object must be one of the following:

- a hazardous material, *or*
- involuntarily damaged beyond all treatment and determined to have no scientific, cultural, historic, educational, esthetic or monetary value

Note: Generally, worn out reproductions and objects consumed through approved consumptive use fall under this category.

10. *Does the collections advisory committee review deaccessions that involve voluntary destruction or abandonment?*

Yes. The collections advisory committee members (see Section D.4-D.6) must review deaccessions that involve voluntary destruction or abandonment. The superintendent must attest to the destruction or abandonment in a memorandum. The memo must have:

- the date, place, and method of destruction or abandonment
- the catalog number(s) of the object(s) that were destroyed or abandoned

Follow Board of Survey procedures (see Section I.4) for witnessing and documenting destruction and abandonment.

11. *Are there special procedures for*

Yes. The safety officer must be involved in all deaccessions involving hazardous materials. Refer to *MH-I*, Chapter 11, Curatorial Health and

deaccessioning hazardous materials?

Safety and *Loss Control Management Guideline.*

<i>If . . .</i>	<i>Then . . .</i>
hazardous materials are an immediate threat	you can destroy or dispose of them immediately without committee review
hazardous materials are not an immediate threat	follow regular procedures, including committee review

12. *Are there special procedures for deaccessioning by abandonment?*

Yes. Abandonment consists of relinquishing title to and possession of an object without vesting it in another institution or person. When the NPS abandons an object it must have no intention of reclaiming it.

Abandonment is a very rare action. The regional director, or other authorized reviewing official who is not directly accountable for the property, must approve abandonment. See 41 CFR-101-45.902-2.

Refer to Section L.10-L.12 for additional information on abandonment.

J. Outside Scope of Collection (See Flow Charts Figures 6.3 and 6.4)

Refer to Sections D-G for processing, documenting, tracking and packing and shipping deaccessions.

1. *What types of objects are outside the park's Scope of Collections Statement (SOCS)?*

Objects in this category are not relevant to the mission and purpose of the park. Carefully consider the park's SOCS before making this determination. You should not deaccession objects that are original to the site and within the SOCS.

You must use extreme caution when deaccessioning objects in this category. The objects must:

- be clearly outside the time, area, and subject limits defined in the SOCS, *or*
- greatly exceed the number of objects of that type needed in the collection for research, interpretation, and exhibition

The park must have a current, approved Scope of Collection Statement to deaccession in this category. Refer to the MH-I, Chapter 2, for information on writing a scope of collection statement.

2. *How can I deaccession objects that are outside my park's SOCS?*
- If objects are outside the park's SOCS, you may deaccession the objects by:
- transfer within the NPS or to other qualified federal agencies, including the Smithsonian Institution (see Sections J.9 and L.2)
 - exchange with other NPS units, other qualified federal agencies, non-federal governmental entities, private institutions or individuals (see Sections J.10 and L.3-L.6)
 - conveyance (donation) to private institutions or non-federal governmental entities, as defined in Section B.3 (see Sections J.11 and L.7)
 - voluntary destruction or abandonment (see Sections L.10-L.12)
3. *Can I deaccession archeology collections as outside the park's SOCS?*
- No. By NPS policy, archeological and natural history collections and associated records acquired as a result of *systematic investigations* within the park boundary:
- cannot be deaccessioned under this category
 - must be maintained intact as part of the park's resources, and therefore cannot be outside the Scope of Collection Statement
- Refer to the *Cultural Resource Management Guideline*, Chapter 9.
- The only exceptions to this policy are NAGPRA-related items, and collections from land that was subsequently deauthorized.
4. *May I deaccession archeological collections that include NAGPRA material?*
- Yes. If appropriate, NAGPRA items may be deaccessioned pursuant to the Native American Graves Protection and Repatriation Act (25 U.S.C. §§ 3001-3013). See the NAGPRA procedures in Section N of this chapter. The deaccession is a NAGPRA deaccession. It's not an outside SOCS deaccession.
5. *May I deaccession archeology collections from land that has been deauthorized?*
- Yes. If park land has been deauthorized, the park may deaccession archeology collections from the deauthorized land to a qualified recipient. The collections must remain in the public trust, and the transaction must be consistent with any applicable guidance in 36 CFR 79 and 36 CFR 2.
- Refer to Appendix A in this handbook for information about deaccessioning objects recovered under the Antiquities Act.
6. *Can I deaccession natural history collections as outside the park's SOCS?*
- No. Natural history specimens in a NPS museum collection in compliance with the Code of Federal Regulations (36 CFR 2.5g) cannot be:
- outside the Scope of Collection Statement
 - deaccessioned in this category
- Refer to Section VI of Chapter 4 in this handbook and the *Cultural Resource Management Guideline*, Chapter 9.
7. *May I deaccession natural history collections from*
- Yes. If park land has been deauthorized, the park may deaccession natural history collections from the deauthorized land to a qualified recipient. The

land that has been deauthorized?

collection must remain in the public trust, and the transaction must be consistent with any applicable requirements in 36 CFR 2.

8. *What do I need to know about title and restriction verifications?*

Before transferring, exchanging, or conveying (donating) objects, you must verify in writing that:

- the park legally owns (has title to) the objects proposed for deaccessioning
- the objects are not subject to ownership (title) or disposition restrictions that may prevent deaccessioning

For example, a restriction may require that objects must permanently remain at the park. In such a case, you must either keep the objects or petition a court of law to have the restriction removed.

Place the written verification in the deaccession package.

9. *What is a transfer?*

A transfer conveys title and control of a museum object from one NPS collection to another federal museum collection. You may transfer objects to other federal agencies that have programs to preserve and interpret cultural or natural heritage. Transfers between parks or other agencies within DOI don't require the review of the collections advisory committee.

Transfers to other federal agencies outside DOI require the review of the collections advisory committee. See Sections D.4-D.6.

10. *What is an exchange?*

In an exchange, the NPS conveys title and control of a museum object to another party. The NPS receives an object owned by the other party in return.

You must accession the objects received in the exchange into the museum collection. You may exchange with:

- another park (however, doing two transfers is simpler)
- another federal agency
- a non-federal governmental entity
- a private institution or an individual.

Exchanges between parks and within DOI don't require the review of the collections advisory committee.

All exchanges outside the DOI require the review of the collections advisory committee. See Sections D.4-D.6.

Note: The NPS requires formal appraisals for exchanges outside the federal government (see Section E.6).

11. *What is a conveyance (donation)?*

A conveyance (donation) transfers title and control of museum objects to private institutions and non-federal governmental entities. The recipient institution must be:

- dedicated to the preservation and interpretation of natural or cultural heritage
- qualified to manage the objects prior to any conveyance (donation)

In addition, private institutions must be exempt from federal taxation under section 501(c)(3) of the Internal Revenue Code of 1986.

All conveyances (donations) require the review of the collections advisory committee. See Sections D.4-D.6.

K. Outside SOCS Requirements

You must follow the requirements in this section to deaccession objects that are outside the park's SOCS.

1. *What are the special requirements for deaccessions outside the park's SOCS?*

The special requirements for deaccessioning objects that are outside the park's SOCS include:

- following the order of preference for recipients
- advertising objects throughout the NPS
- using the collections advisory committee to recommend deaccessions outside the DOI and voluntary destruction/abandonment (see Sections D.4-D.6)
- getting formal appraisals for all exchanges outside the DOI (see Section E.6)
- placing a 45-day public notice on the World Wide Web for all exchanges outside the federal government and all conveyances (donations)

2. *What is the order of preference for deaccessioning objects that are outside a park's SOCS?*

You must follow the order of preference below when deaccessioning objects that are outside the park's SOCS.

- transfer to another NPS park or center
- exchange with qualified federal agencies
- transfer to qualified federal agencies
- exchange with private institutions or non-federal governmental entities that meet the criteria of Section J.11
- conveyance (donation) to private institutions or non-federal governmental entities that meet the criteria of J.11
- exchange with individuals or entities other than those listed above

- voluntary destruction or abandonment

The exchange of objects with private individuals and non-educational or non-cultural institutions is not recommended. According to NPS procedures and generally accepted museum practice, such exchanges should occur only if the exchange is explicitly justified in writing and no other alternatives are available.

3. *Why is there an order of preference for deaccessions?*

The order of preference is based on:

- maintaining federal government interest
- keeping the collections in the public trust
- protecting NPS interest (or “investment”)

4. *What if there is more than one potential recipient?*

If more than one recipient is available, choose the option that offers the greatest:

- benefit to the park and the NPS
- ability to care for the objects
- ability to preserve the objects in the public sector
- likelihood for public benefit, such as research and exhibit
- consistency with the mission and scope of collections of the recipient

5. *How do I evaluate a potential recipient’s qualifications?*

You may have to evaluate a potential recipient’s qualifications to receive and properly care for museum collections. To demonstrate their qualifications, potential recipients may provide:

- 501(c)3 tax exempt determination (see Section B.3)
- American Association of Museums (AAM) accreditation
- mission statement demonstrating dedication to natural or cultural preservation and interpretation
- Museum Assessment Program (MAP) or Conservation Assessment Program (CAP) survey
- facility report demonstrating preservation and protection capability

6. *Can a park ever deaccession objects out of the order of preference?*

Yes. With written justification, the superintendent can deaccession objects out of the order of preference. The reason for this action must be well justified.

7. *How do I determine whether other parks need the objects?*

You should not transfer, exchange or convey (donate) objects outside the NPS, or voluntarily destroy objects, if the objects are appropriate to and needed by other parks in the system.

You must determine whether you can transfer or exchange objects proposed for deaccessioning within the Service. Consult with:

- the regional/SO curator
- other parks
- the NPS Clearinghouse, Museum Management Program, National Center for Cultural Resources (see Section O of this chapter)
- the Harpers Ferry Center Department of Historic Furnishings, if appropriate

Contact any interested parks or advertise the objects throughout the Service. It is sufficient to advertise on the Curatorial Bulletin Board in cc:Mail or in the *Clearinghouse Classifieds* newsletter.

Allow at least thirty days from the date of publication for parks to respond to the advertisement. Document all responses. Include documentation in the deaccession package to show that:

- you have circulated the information about the objects throughout the Service
- no park wants the objects (or why the park denied NPS requests for the objects)

8. *When must I publicly advertise a deaccession?*

The park must publish a public notice of intent to deaccession objects to an intended recipient before:

- exchanging objects outside the federal government
- conveying (donating) objects

9. *Where must I place the public notice?*

The park must publish the notice in the Clearinghouse listing on the NPS Museum Management Program World Wide Web site. Refer to Section O for submission procedures.

Note: If you advertised on the World Wide Web for non-NPS recipients, this will be the second time you advertise on the Web.

The NPS will use the AAM newsletter *Aviso* and the American Association for State and Local History (AASLH) newsletter *History News* to publicize the World Wide Web posting. The park must allow at least forty-five days from the date of publication for institutions to register a request or protest.

10. *What must I include in the public notice?*

The notice must include:

- the intent to convey (donate) or exchange objects
- the intended recipient
- a list of the objects that includes the park name, object name, brief

description, material, artist/maker, date, and catalog number

- information on how to contact the park, such as a person to contact and phone number

11. *What happens after the notice has been on the WWW for forty-five days?*

<i>If. . .</i>	<i>Then. . .</i>
the park receives no requests or protests over the deaccession within 45 days of publication,	the superintendent signs the deaccession form and the exchange agreement or conveyance (donation) agreement and deaccessions the objects.
the published notice produces requests or protests from other institutions or individuals,	the superintendent consults the collections advisory committee, as appropriate, and determines the recipient.

The superintendent determines the recipient based on the recipient's superior ability to preserve and protect the objects and make them available to the public. The superintendent may request evidence to this effect from the potential recipients (see Section K.5).

L. **Outside SOCS Procedures**

1. *How do I find non-NPS recipients?*

If other parks don't need the objects, explore the other dispositions in the order of preference in Section K.2. Use all reasonably available means to contact institutions that may be in a position to make an exchange.

To locate potential non-NPS recipients, the park may advertise in whatever way it can best reach potentially interested parties, including:

- the Clearinghouse listing on the NPS Museum Management Program World Wide Web site (see Section O for submission procedures)
- the AAM newsletter *Aviso* or other professional newsletters (the park must pay the costs of advertising)
- regional or local publications or listings, if appropriate

The notice should include:

- the intent to deaccession objects
- a list of the objects
- information on how to contact the park, such as a person to contact and phone number

Allow at least forty-five days from the date of publication for response. A longer period of time may be needed for complex transactions. The park and the potential recipient can negotiate for additional time.

Note: You will have to advertise a second time on the World Wide Web if

you find a recipient and intend to exchange objects outside the federal government or convey (donate) objects. See Sections K.8-K.11.

2. *How do I document a transfer?*

Use a Transfer of Property, DI-104 (Figure 6.10) to legally document a transfer. ANCS+ will print a completed transfer. Include a statement on the transfer to verify that the NPS owns the objects. The statement should note that there are no ownership or disposition restrictions on the objects.

Example of a title verification statement: The NPS certifies that it holds free and clear title to the subject property. The NPS may dispose of the property in any manner that it determines is appropriate and lawful.

For transfers within the NPS, the superintendents of both parks must sign the transfer. For transfers to other DOI bureaus or federal agencies, the park superintendent and the appropriate bureau or agency accountable officer must sign the transfer.

Keep the original documentation and give the recipient archival quality copies of the pertinent accession and catalog documentation. Give non-NPS recipients copies of only the documentation essential to future management of the object.

3. *What are some special considerations for exchanges?*

Before conducting an exchange, you must make sure that:

- the exchange is fair, justified, and in the public interest
- every effort has been made to keep museum objects in the public sector
- the objects received from the exchange fit the SOCS and are of a quality appropriate for the NPS museum collections
- there is a need for the objects received from the exchange and the park can adequately care for them

Consult the regional/SO curator before exchanging natural history specimens. Don't exchange type or voucher specimens.

4. *Can an exchange be unequal in monetary value?*

Yes. Objects in an exchange should be approximately equal in monetary value. However, it is sometimes appropriate to exchange NPS objects for objects of lesser monetary value. This situation might occur when the NPS has a great need for the objects and has been unable to get them elsewhere. You must fully describe such circumstances in the justification. Exchanging NPS objects for objects of greater value is also acceptable.

You must get formal, written appraisals for exchanges outside the federal government. You must get appraisals for both the objects you deaccession and the objects you acquire through an exchange. Get a minimum of one appraisal for objects below \$20,000 in value. Get two appraisals for objects over \$20,000 in value. See Section E.6.

5. *How do I document an exchange?*

You must document an exchange with a written legal agreement. You can print an exchange agreement from ANCS+. The superintendent and the bureau or agency accountable officer or owner sign the exchange agreement. See Figure

6.11 for a sample exchange agreement. You may create your own exchange agreement, but it must include the introduction and sections 1-9 of the sample exchange agreement.

6. *What documents do I attach to the exchange agreement?*

Attach these documents to the exchange agreement:

- a list of the non-NPS objects to be acquired
- a list of the NPS objects to be exchanged
- the required appraisals for exchanges outside the federal government (see Section E.6)
- a written and signed proof of ownership statement from the other party

Include a justification to show why the exchange is in the best interest of the NPS and the general public. Include a statement on the exchange agreement to verify that the NPS owns the objects and that there are no ownership or disposition restrictions on the objects. (See example statement in Section L.2.) Make every effort to acquire the copyrights for the materials you acquire in an exchange, especially if they are held by the current property owner. Document any and all restrictions clearly and spell out when such restrictions expire.

Refer to Chapter 2 in this handbook and the NPS *Museum Handbook*, Part III (*MH-III*), Chapter 2, Legal Issues, for information on copyrights.

Keep the original documentation and give the recipient archival quality copies of the pertinent accession and catalog documentation. Give non-NPS recipients copies of only the documentation essential to future management of the object.

7. *When do I post a World Wide Web notice of intent to exchange?*

If you are doing an exchange outside the federal government, you must post a 45-day notice of intent to exchange on the World Wide Web. Post the notice when you have found a recipient. Refer to Sections K.8-K.11 and Section O for additional information about the notice.

8. *How do I document a conveyance (donation)?*

Use a Conveyance (Donation) Agreement, Form 10-99 (Figure 6.13) to legally document the conveyance (donation) of museum objects to a private institution or non-federal governmental entity. You can print a completed conveyance (donation) agreement from ANCS+.

The superintendent signs for the park. The responsible official signs for the institution.

Keep the original documentation and give the recipient archival quality copies of the pertinent accession and catalog documentation. Give the institution copies of only the documentation essential to future management of the object.

9. *When do I post a World Wide Web notice of intent to convey (donate)?*

All conveyances (donations) require a 45-day notice on the World Wide Web. Post the notice when you have found a recipient. Refer to Sections K.8-K.11 and Section O for additional information about the notice.

10. *When can I use voluntary destruction or abandonment to deaccession museum objects?*

Before destroying or abandoning museum objects you must determine that they have no scientific, cultural, historic, educational, esthetic, or monetary value.

Generally, if you can't deaccession the objects through any other way, you can propose destruction or abandonment. The justification for this type of deaccession must include the steps you took to determine that the objects have

no value.

The NPS may not destroy or abandon objects that are outside a park's Scope of Collection Statement unless all other disposition methods have failed.

The collections advisory committee members must review all actions to destroy or abandon museum objects. The superintendent must approve and request destruction. In accordance with 41 CFR-101-45.902-2, the regional director, or other authorized reviewing official who is not directly accountable for the property, must approve abandonment.

11. *What are some special considerations for voluntary destruction or abandonment?*

Abandonment is a very rare action. Abandon objects only when destruction is not feasible. For example, a large piece of badly rusted mining equipment may be too large to move.

If the park abandons museum objects, the superintendent should take some type of mitigating action. For example, the park could place an explanatory sign by abandoned property. Such actions will counter potential public perception that the park is not properly caring for its resources.

As part of the destruction process, objects may be reduced to scrap, destroyed, or cannibalized and the remainder destroyed. Cannibalized parts are designated expendable personal property. They may be used for park maintenance providing that the use has no scientific, cultural, historical, educational, interpretive or esthetic purpose. For example, nuts and bolts may be cannibalized from a disintegrated wooden crate that has been approved for destruction. The park maintenance division may reuse the nuts and bolts. The wooden scraps are burned.

The superintendent, considering the recommendations of the collections advisory committee, may request a particular destruction process. The Board of Survey must recommend the process.

12. *How do I document voluntary destruction or abandonment?*

Follow the Board of Survey procedures in Section I of this chapter and the Personal Property Handbook No. 44.

Note: Section I of this chapter has information on voluntary destruction/abandonment for objects within the park's SOCS. This is a different type of deaccession from voluntary destruction/abandonment of objects outside the park's SOCS. The Board of Survey procedures for both types of deaccession are the same.

M. Destructive Analysis

Refer to Sections D-F for processing, documenting, and tracking deaccessions.

1. *When do I deaccession objects under the destructive analysis category?*

Deaccession objects in this category only when the entire object is destroyed in analysis.

2. *Who approves destructive analysis?*

The superintendent may approve destructive analysis for research purposes for cultural resource collections when the object is common. The superintendent may approve destructive analysis for research purposes for natural resource collections when:

- the request is based on a professional research design that clearly documents the scientific need for the use of destructive analysis
- the specimen doesn't represent an extinct species or a type or voucher specimen

The regional director must approve all requests for destructive analysis that involve rare or significant objects, specimens, and archival items. The regional/SO curator should review such requests and arrange for review by appropriate discipline specialists.

3. *How do I document destructive analysis?*

Follow the Board of Survey procedures in Section I of this chapter and the *Personal Property Management Handbook No. 44*.

4. *Where can I find information on destructive analysis?*

For guidelines on destructive analysis, refer to:

- Section V of Chapter 4 in this handbook
- *Cultural Resource Management Guideline*, Chapter 9

N. Native American Graves Protection and Repatriation Act (See Flow Chart Figure 6.5)

Refer to Sections D-G for processing, documenting, tracking, and packing and shipping deaccessions.

The NPS may deaccession museum collections in compliance with the Native American Graves Protection and Repatriation Act (NAGPRA) of 1990 [25 U.S.C. §§ 3001-3013].

1. *What types of items are subject to NAGPRA?*

Lineal descendants, Indian tribes, Native Hawaiian organizations and Alaska Native villages and corporations may request the repatriation of certain:

- human remains
- associated funerary objects
- unassociated funerary objects
- sacred objects

- objects of cultural patrimony

To determine which items are eligible for deaccessioning by repatriation, refer to:

- definitions of NAGPRA categories outlined in the statute (items *must* fit the definitions to be considered for repatriation)
- *Cultural Resource Management Guideline*, Appendix R: NAGPRA Compliance

2. *Who can request repatriation?*

The request for repatriation must be from a lineal descendant or an official representative of an Indian tribe, Native Hawaiian organization or Alaska Native village or corporation. You must receive this request in writing or document it in writing.

3. *How do I respond to requests for summary items?*

Summaries are written descriptions of collections that may have unassociated funerary objects, sacred objects, or objects of cultural patrimony. Parks prepared summaries in compliance with NAGPRA. The NPS sent summaries to tribes, Native Hawaiian organizations, and Alaska Native villages and corporations in 1993.

Requests for summary items must include evidence supporting the claim.

On receiving a request for repatriation, you should notify and consult with the regional/SO curator. See Section N.5. Give the regional/SO curator the available documentation that includes:

- a copy of the request for repatriation
- copies of accession and catalog records
- completed affiliation data that:
 - identifies and supports the claim of the lineal descendant, Indian tribe, Native Hawaiian organization, or Alaska Native village or corporation with whom the items are culturally affiliated
 - includes information on how the cultural affiliation was determined
 - includes a list of consultations conducted with relevant Indian tribes, Native Hawaiian organizations or Alaska Native villages or corporations

4. *How do I respond to requests for inventory items?*

Inventories are item-by-item descriptions of human remains and associated funerary objects. The NPS completed inventories of human remains and associated funerary objects by November 16, 1995.

When you receive a repatriation request for an inventory item from the culturally affiliated tribe(s), you should notify the regional/SO curator.

Prepare the deaccession package as noted in Section N.6. For inventory items:

- the regional/SO staff have already recommended a cultural affiliation

- the superintendent has already approved cultural affiliation
5. *Who does the regional/SO curator consult about repatriations?*
- The regional/SO curator should consult with the regional/SO archeologist, ethnographer, NAGPRA coordinator, or NAGPRA committee. These staff make recommendations concerning the repatriation. Record their recommendations in the Notes field of the ANCS+ Deaccessions associated module.
6. *What do I include in the deaccession package?*
- You prepare the deaccession package. In addition to the documentation listed in Section E.3, the package must contain:

- the request for repatriation or documentation of the request
- completed cultural affiliation data as described in Section N.3
- a repatriation agreement or equivalent (see optional sample, Figure 6:12)
- the regional/SO recommendation, as appropriate

Make a recommendation to approve or disapprove the repatriation request. You can print a repatriation agreement from ANCS+. You then forward the deaccession package to the superintendent.

Note: You can't recommend against repatriating inventory items.

7. *What does the superintendent do with the deaccession package?*

The superintendent must:

- review the park and regional/SO recommendations, as appropriate
- approve or disapprove the repatriation of summary items (the superintendent can approve all or selected items for repatriation)
- approve repatriation of inventory items
- prepare a written response to the requester

By including items in the NAGPRA inventory, the superintendent has approved repatriation of those items to the culturally affiliated tribes. The superintendent can't disapprove repatriation of items listed in the NAGPRA inventory.

8. *What happens to disapproved requests?*

The superintendent may disapprove the repatriation on the grounds that:

- the items do not fit NAGPRA definitions
- the individual or group making the claim doesn't have standing to make such a claim (is not on the list of recognized tribes maintained by the National NAGPRA Program for the purposes of implementing NAGPRA)
- no relationship of shared group identity can be traced between the present-day Indian tribe and the affiliated cultural group associated with the item
- there is insufficient documentation to support the claim

The superintendent must notify the requester of this decision in writing. See Section F.1 on filing disapproved deaccessions. The individual or tribe can appeal decisions to the NAGPRA Review Committee. Refer to the *Cultural Resource Management Guideline*, Appendix R: NAGPRA Compliance.

Note: A Web-based database provides NAGPRA contacts for the federally recognized tribes. The Bureau of Indian Affairs web site at <http://www.cr.doi.gov/bia/tribes/entry.html> provides access to the database.

9. *What happens to approved requests?*

The superintendent may approve the repatriation but must inform the requester of the 30-day Federal Register notice requirement. See Section N.10. All approved repatriations must identify the federally recognized tribe in the Affiliated Tribes field of the ANCS+ NAGPRA supplemental record.

After the 30-day Federal Register notice and the resolution of any claim disputes:

- the superintendent signs the deaccession form and repatriation agreement
- the recipient(s) signs the repatriation agreement and receives the repatriated items

10. *What is the Federal Register notice?*

The Federal Register notice is a NAGPRA requirement.

Repatriation cannot take place until at least thirty days after a notice of intent to repatriate has been published in the Federal Register.

If the superintendent approves the request for repatriation, he or she sends:

- a notice regarding the proposed repatriation of museum items to the Manager, Archeology and Ethnography Program, National Center for Cultural Resources, for publication in the Federal Register

To make sure that no counter claims have been received, contact the regional/SO curator or NPS NAGPRA coordinator.

<i>If . . .</i>	<i>Then . . .</i>
no additional claims are received within 30 days of publication,	the park repatriates the items.
the published notice produces additional claims,	the claimants settle the dispute, and the park repatriates the items.
the claimants don't settle the dispute,	the NAGPRA Review Committee reviews and resolves the dispute.
	Repatriation cannot occur until the committee resolves the dispute.

All the NAGPRA notices of repatriation published in the Federal Register and inventory completion appear on the web at <http://www.cr.nps.gov/nagpra/>.

Note: The NAGPRA Review Committee is a statutorily established panel of seven private citizens. The committee is charged with facilitating the resolution of NAGPRA-related disputes nationwide.

11. *Are there time limits for responding to a repatriation request?*

Yes. The requested repatriation is to take place within 90 days of the initial request if:

- the objects meet the NAGPRA definitions (refer to the NPS NAGPRA consultation guidelines in the *Cultural Resource Management Guideline*, Appendix R: NAGPRA Compliance), *and*
- appropriate supporting documentation is available, *and*
- the proposed repatriation is approved

12. *What documentation should I give to the recipient?*

Keep the original documentation and give the recipient archival quality copies of the pertinent accession and catalog documentation.

Send a copy of the deaccession form or repatriation agreement to the central NAGPRA file maintained by the Museum Management Program, National Center for Cultural Resources. This copy is for informational purposes only. Send it to Museum Management Program, National Park Service, 1849 C Street, NW, Room NC230, Washington, DC 20240, Attn: Chief Curator.

O. NPS Clearinghouse Services

1. Can the NPS Clearinghouse help parks with deaccessions?

Yes. The NPS Clearinghouse, administered by the Museum Management Program, National Center for Cultural Resources, can help parks with deaccessions by:

- giving advice on deaccession procedures and assistance in preparing deaccession transactions
- helping you to locate potential recipients for museum objects that are outside your park's Scope of Collection Statement
- advertising objects throughout the NPS and to non-NPS institutions
- giving advice on appraisals and lists of appraisers

2. *How does the NPS Clearinghouse advertise objects for deaccession?*

The NPS Clearinghouse uses various means to advertise objects outside a park's Scope of Collection Statement. These include the *Clearinghouse Classifieds* newsletter and a World Wide Web listing.

By advertising through the Clearinghouse, you can determine whether objects are needed by other parks before deaccessioning them outside the NPS. The Clearinghouse newsletter also allows you to advertise to many non-NPS subscribers.

Use the Clearinghouse World Wide Web listing to advertise for non-NPS recipients. See Section L.1. You must use this listing to advertise your intent to exchange or convey (donate) outside the federal government. See Sections K.8-K.11.

Note: The NPS Clearinghouse doesn't accept physical custody of museum objects.

3. *How do I send information to the Clearinghouse newsletter?*

Send information to the NPS Clearinghouse newsletter (*Clearinghouse Classifieds*) to advertise for NPS and non-NPS recipients.

Send information to: NPS Clearinghouse
Bombshelter, Filmore Street
Harpers Ferry, WV 25425
Phone: 304-535-6204
Fax: 304-535-6203

Send electronic copy to: WASO National Catalog Office

The *Clearinghouse Classifieds* is published twice a year. Advertisements are free.

4. *May I post information about potential deaccessions on the Curatorial Bulletin Board?*

Yes. You may post information directly on the Curatorial Bulletin Board in cc:Mail to advertise for NPS recipients.

5. *How do I publish notices on the Clearinghouse World Wide Web listing?* Send electronic submissions in an attached file, using the current NPS software, via cc:Mail to "Clearinghouse-WWW". Refer to the appropriate sections below for what to include in the notice. The NPS Museum Management Program World Wide Web site is at <<http://www.cr.nps.gov/csd/>>.

For publishing notices to advertise for NPS recipients, see Section L.1.

For publishing a notice of intent to deaccession objects by conveyance (donation) or exchange outside the federal government, see Sections K.8-K.11.

P. List of Figures

Figure 6.1	Flow Chart for Deaccessioning - Return to Rightful Owner
Figure 6.2	Flow Chart for Deaccessioning - Loss, Theft, Damage or Involuntary Destruction, and Voluntary Destruction/Abandonment
Figure 6.3	Flow Chart for Deaccessioning - Outside Scope of Collection Statement - Transfer and Exchange
Figure 6.4	Flow Chart for Deaccessioning - Outside Scope of Collection Statement - Conveyance (Donation) and Voluntary Destruction/Abandonment
Figure 6.5	Flow Chart for Deaccessioning - Native American Graves Protection and Repatriation Act
+* Figure 6.6	Deaccession Form (Form 10-643)
+ Figure 6.7	List of Objects (Form 10-417), [Optional]
+ Figure 6.8	Deaccession Folder Cover Sheet (Form 10-644), [Optional]
Figure 6.9	Deaccession Book (Form 10-642), [Optional]
+* Figure 6.10	Transfer of Property (DI-104)
+ Figure 6.11 a-b	Exchange Agreement (Sample)
+ Figure 6.12 a-b	Repatriation Agreement (Sample)
+* Figure 6.13	Conveyance (Donation) Agreement (Form 10-99)
Figure 6.14	Collections Advisory Committee Procedures (Sample)
+ Figure 6.15	Specialist Review Form (Sample)

+ Print these forms from ANCS+.

* You must use the Deaccession Form (Form 10-643) for all deaccessions. You must use the Transfer of Property (DI-104) for all transfers between federal entities. You must use the Conveyance (Donation) Agreement (Form 10-99) for all conveyances (donations).

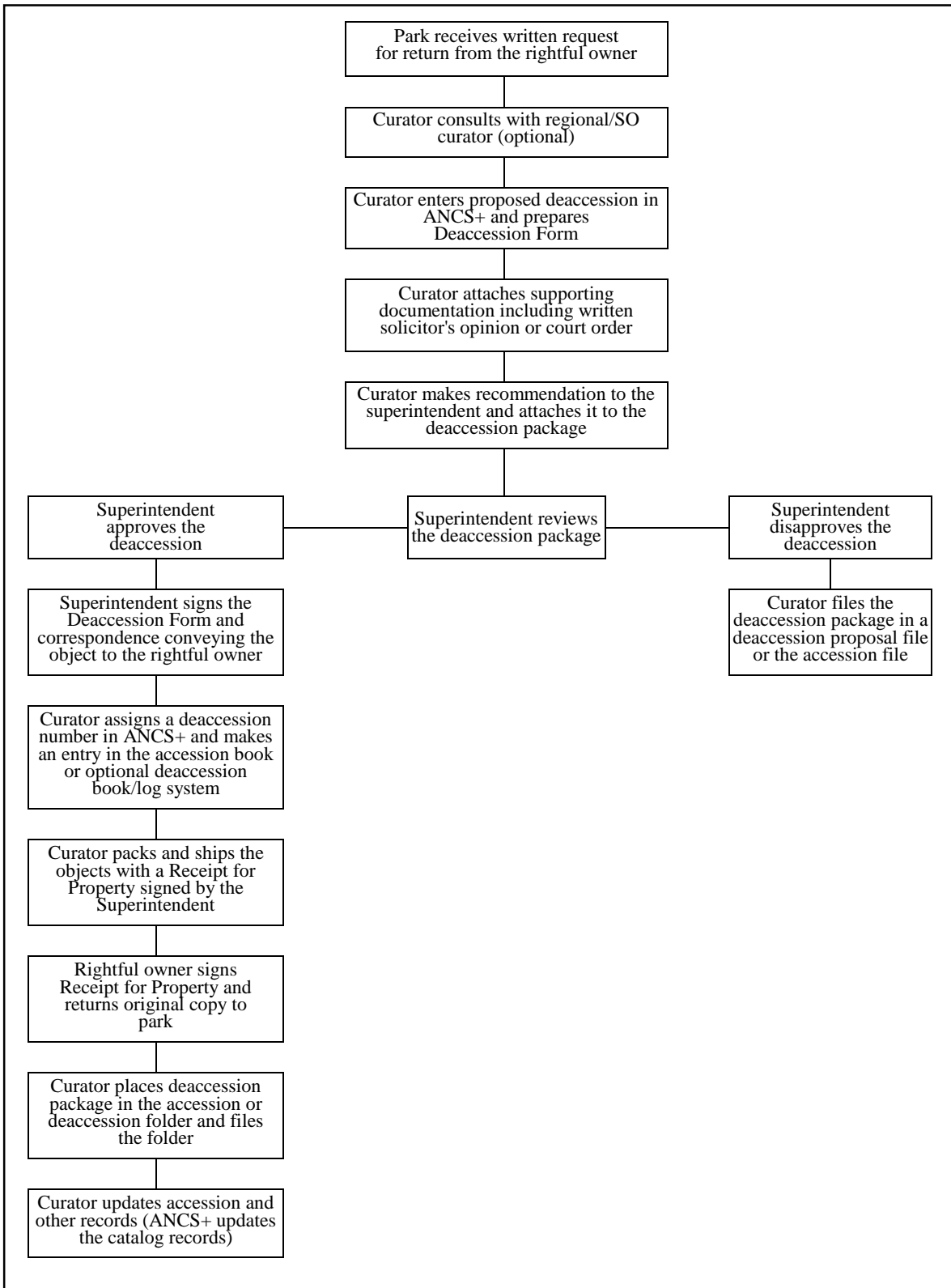

**Figure 6.1. Flow Chart for Deaccessioning:
Return to Rightful Owner**

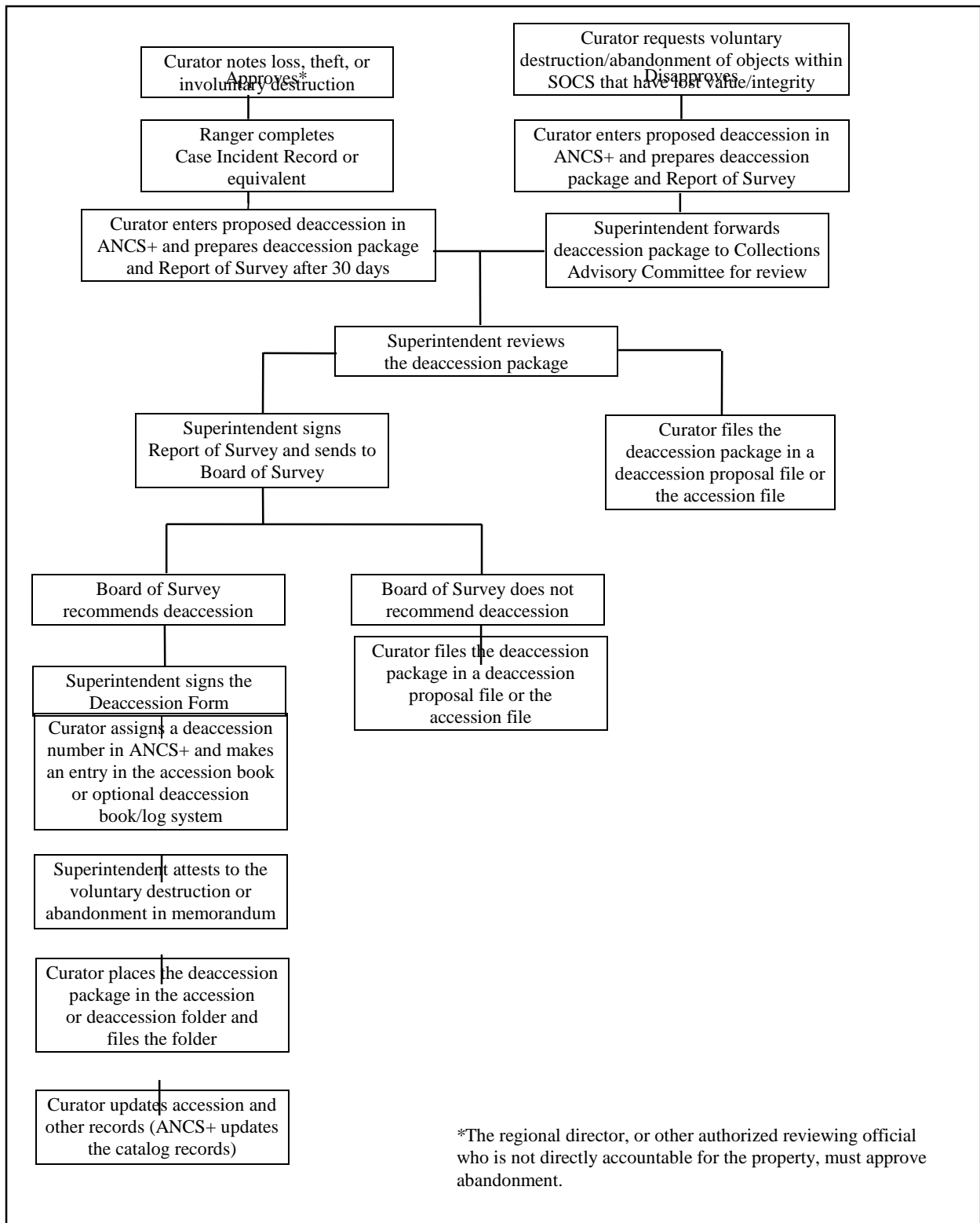

Figure 6.2. Flow Chart for Deaccessioning: Loss, Theft, Involuntary Destruction, and Voluntary Destruction/Abandonment

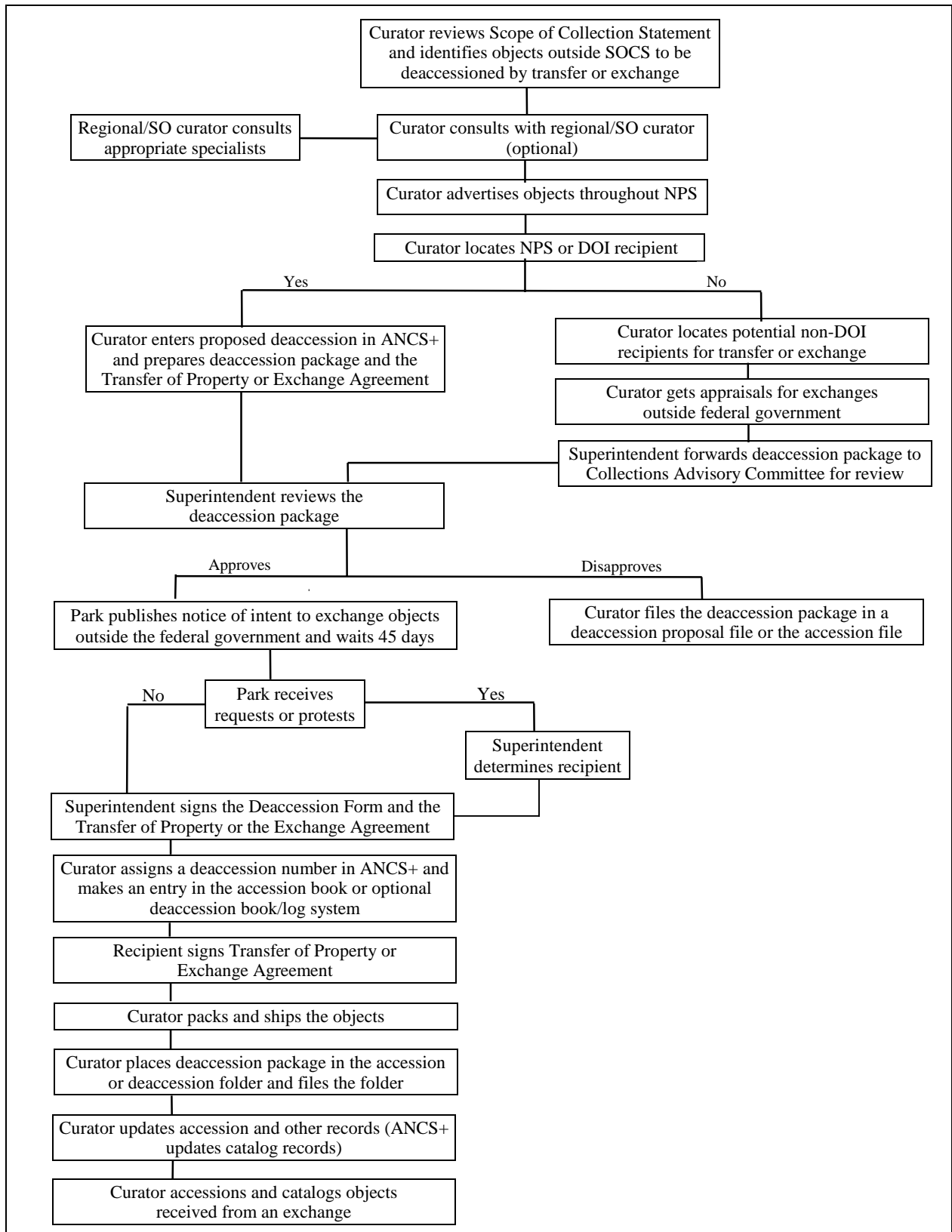

Figure 6.3. Flow Chart for Deaccessioning: Outside Scope of Collection Statement Transfer and Exchange

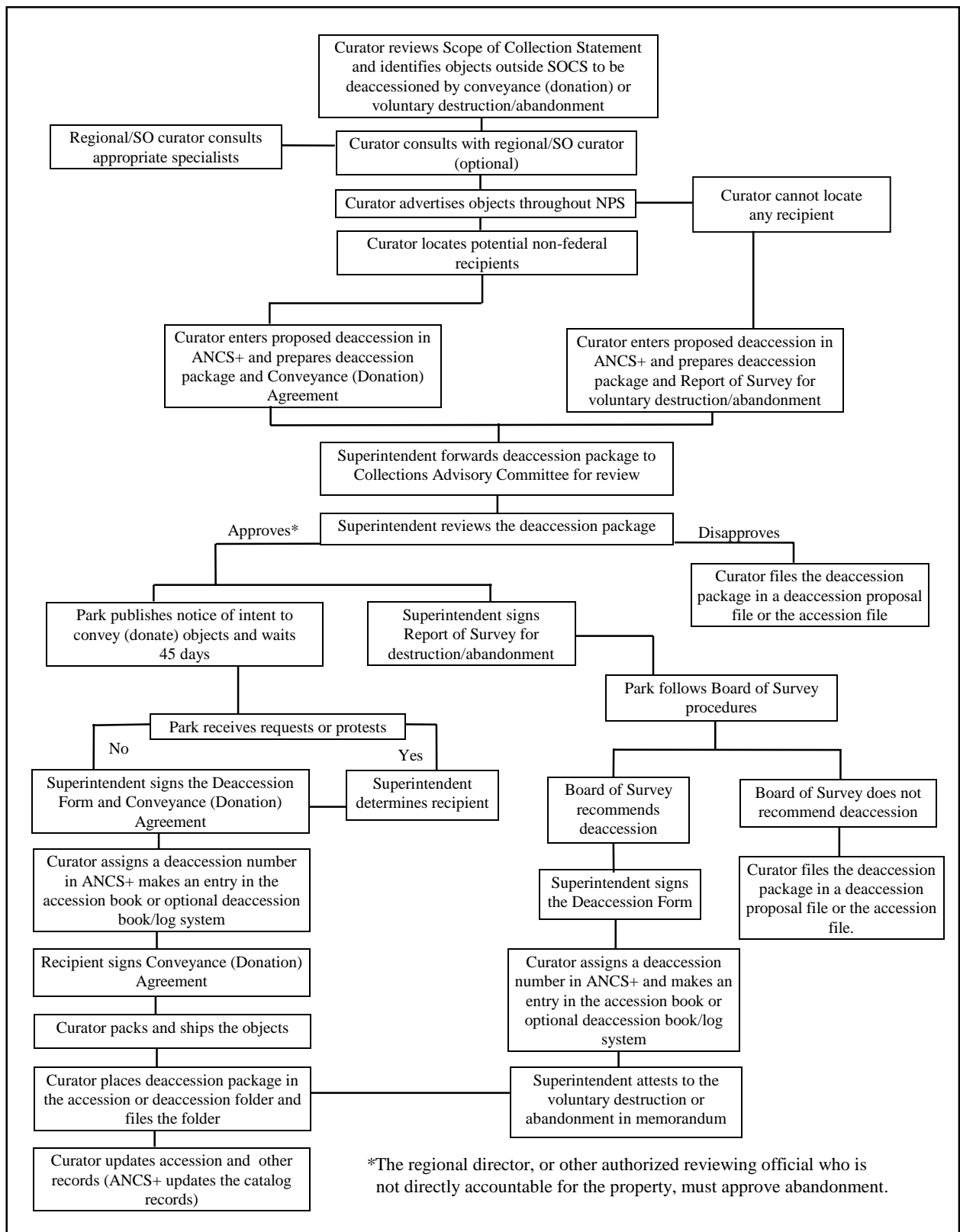
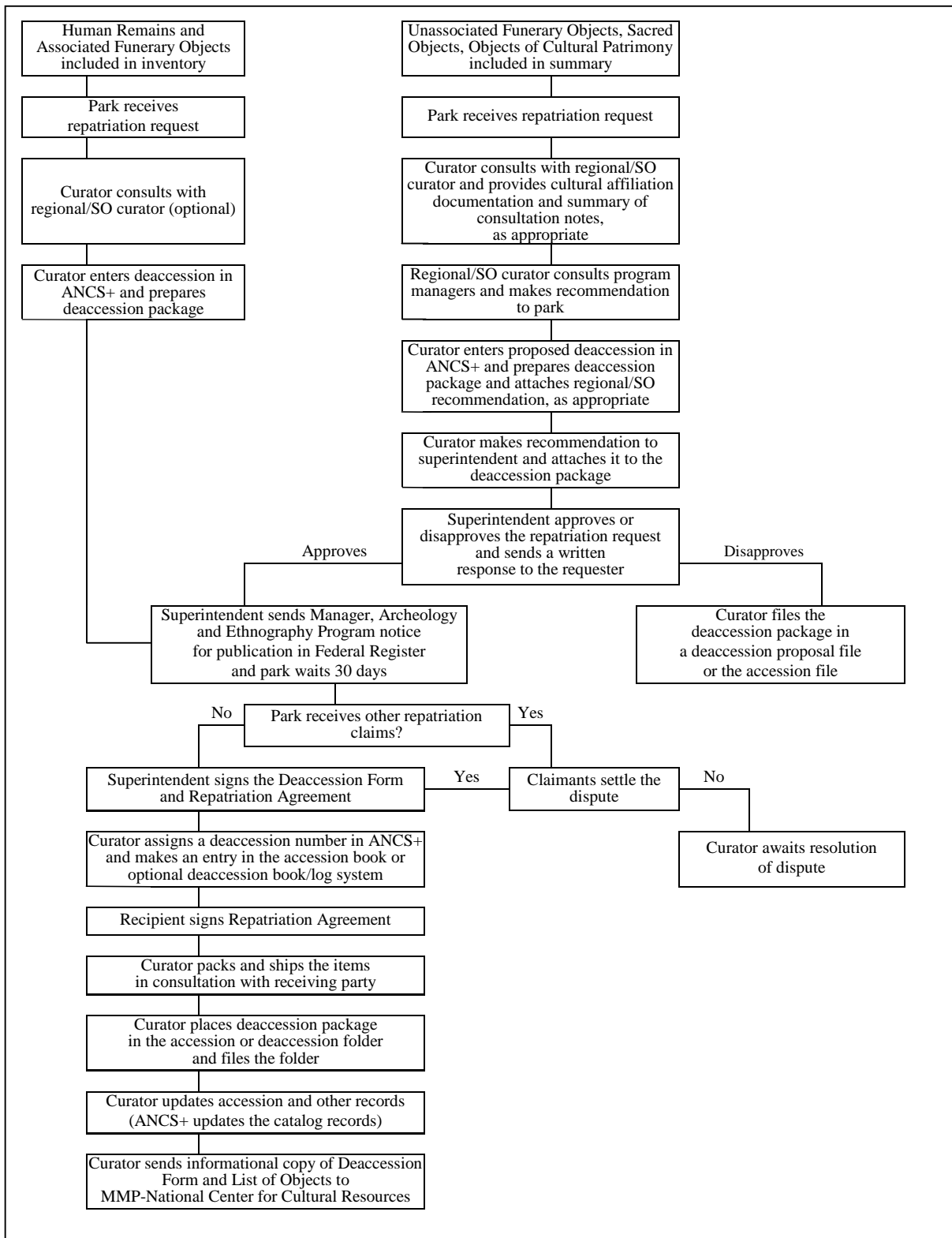

Figure 6.4. Flow Chart for Deaccessioning: Outside Scope of Collection Statement Conveyance (Donation) and Voluntary Destruction/Abandonment



**Figure 6.5. Flow Chart for Deaccessioning:
Native American Graves Protection and Repatriation Act**

Deaccession Form

Deaccession Number _____

Park Name _____

DEACCESSION TYPE: _____

DISPOSITION OF OBJECTS OUTSIDE SOC: _____

OBJECTS IN DEACCESSION:

Number of Objects: _____

Value _____

(Attach List of Objects, or for a few objects, list required information here)

DISPOSITION DOCUMENT (attached): _____

ATTACHMENTS: _____

NOTES ON DEACCESSION: _____

CURATORIAL REVIEW AND RECOMMENDATION:

Deaccession Recommended: (if no, attach explanation)

Disposition Recommended: (if no, attach explanation)

Curator: _____

Print Name

Signature

Date

COLLECTIONS ADVISORY COMMITTEE MEMBER REVIEW AND RECOMMENDATION

- See attached Collections Advisory Committee Member Review (required for non-DOI transfers, conveyances, non-DOI exchanges, voluntary destruction)

APPROVAL:

Deaccession Approved: (if no, attach explanation)

Disposition Approved: (if no, attach explanation)

Attach explanation if decision is contrary to one or more committee member recommendations. Attach written approval from non-accountable reviewing official for abandonment.

Superintendent: _____

Print Name

Signature

Date

Figure 6.6. Deaccession Form (Form 10-643)

US Department of the Interior
National Park Service

Park Acronym _____

Page _____ of _____
 _____ Number

LIST OF OBJECTS

CATALOG NUMBER	ACCESSION NUMBER	ITEM COUNT OR QUANTITY	OBJECT NAME	DESCRIPTION AND CONDITION	VALUE	COMMENT

NPS Form 10-417
 July 1995

Figure 6.7. List of Objects (Form 10-417) [Optional]

Park Name _____

DEACCESSION FOLDER COVER SHEET

INSTRUCTIONS: This Deaccession Folder cover sheet may be used whenever a park deaccessions museum collections. Insert this in the deaccession folder.

A. DEACCESSION INFORMATION IN FOLDER

Deaccession Form

List of Objects

Justifications

Collections Advisory Committee Member Comments

Superintendent Comments

Support Office Curator Comments

Regional Director Comments

B. DEACCESSION TYPE

Return to Rightful Owner

Loss, Theft, or Involuntary Destruction

Voluntary Destruction/Abandonment

Outside Scope of Collection

Destructive Analysis

NAGPRA Compliance

C. DISPOSITION DOCUMENT

Receipt for Property

Report of Survey

Witness Statement for Voluntary Destruction/Abandonment

Exchange Agreement

Transfer of Property

Memorandum (for Destructive Analysis)

Repatriation Agreement

Conveyance Agreement

INDICATE LOCATION OF THE FOLLOWING:

	Accession Folder	Catalog Folder	Deaccession Folder
1. Correspondence relating to deaccession.....			
2. Case Incident Record			
3. Research Notes			
4. Appraisals			
5. Photographs.....			
6. Shipping Documents.....			
7. Documentation of abandonment or destruction.....			
8. NAGPRA Consultation Notes			
9. NAGPRA Cultural Affiliation Documentation			
10. Solicitor's Opinion/Court Order			
11. Other.....			

Figure 6.8. Deaccession Folder Cover Sheet (Form 10-644) [Optional]

DEACCESSION BOOK

Deaccession Number	Deaccession Date	Description	Disposition (Name and Address)	Deaccession Type	Accession Numbers	Catalog Numbers	Number of Items	Remarks

Figure 6.9. Deaccession Book (Form 10-642) [Optional]

DI-104
(Rev. 6/88)

UNITED STATES DEPARTMENT OF THE INTERIOR TRANSFER OF PROPERTY		Page ____ of ____		
		Report No.		
		Date		
Transfer From: (Organization and Complete Address)		Transfer To: (Organization and Complete Address)		
Appropriation and Accounting Data:				
ITEM NO.	QUANTITY OR PROPERTY ID NO.	ITEM DESCRIPTION <i>(Include model & serial number)</i>	ORIGINAL ACQUISITION COST (OAC)	CONDITION CODE

SHIPPING AND RECEIVING INFORMATION			
Date Shipped:		Date Received:	
Authorized Signature:		Authorized Signature:	
Official Title:		Official Title:	
Adjustment to property records (Property Official Signature):	Date Completed	Financial Official Signature (if Required):	Date Completed

U.S. Government Printing Office 1988 673-017/96039

Figure 6.10. Transfer of Property (DI-104)

Exchange Agreement

In accordance with the authority granted to the Secretary of the Interior by the Museum Act of 1955 (16 USC, Sect. 18 [f]), and in consideration of the mutual promises set forth in this Agreement, the National Park Service and _____ (other party) enter into this agreement for the exchange of museum objects.

1. _____ (NPS Unit) hereby becomes the owner of the objects listed on the first attached inventory (Attachment 1 of this Agreement). _____ (other party) hereby becomes the owner of the objects listed on the second attached inventory (Attachment 2 of this Agreement).
2. _____ (other party) represents and warrants that he/she/they will possess clear title, free of all liens, claims, and encumbrances of any kind, to the objects listed in Attachment 1 at the time the exchange takes place. If at the time the exchange is to occur _____ (other party) is unable to present the objects listed on Attachment 1 and proof of ownership for the said objects he/she/they is/are exchanging, the National Park Service is under no obligation to complete the exchange.
3. _____ (other party) represents and warrants that the objects listed on Attachment 1 were secured in compliance with all applicable International, Federal and State laws. Documentation evidencing the source of acquisition of the objects listed on Attachment 1 will be attached to this Agreement at the time the exchange takes place (Attachment 3).
4. _____ (other party) represents and warrants that the objects listed in Attachment 1 have been authenticated and appraised in writing, at market value, by at least one objective appraiser within six months previous to the date of this agreement. Copies of the appraisals for the NPS and non-NPS items are attached to this Agreement (Attachment 4).
5. _____ (other party) represents and warrants that he/she/they is/are the sole owner(s) of all rights in the objects listed on Attachment 1. _____ (other party) hereby assigns in _____ (NPS unit) all of _____ (other party) common law and statutory copyrights to the objects listed in Attachment 1. _____ (other party) agrees to indemnify _____ (NPS unit) against any claims, damages, losses, or expenses of any kind that _____ (NPS unit) may suffer as a result of any infringement or alleged infringement of the copyrights to _____ (NPS unit).
6. Title to the objects exchanged under this agreement shall pass when the objects have been delivered pursuant to the terms of this Agreement and the parties have inspected the objects and found them to be in a satisfactory condition and are as represented in this Agreement. Inspections of the objects shall occur on the date of delivery.
7. As provided by 41 U.S.C. § 22, no member of or delegate to Congress, or Resident Commissioner shall be admitted to any share or part of this Agreement or to any benefit that might arise therefrom; but this provision shall not be construed to extend to this Agreement if made with a corporation for its general benefit.
8. No NPS employee or members of a NPS employee's immediate family shall be admitted to any share or part of this Agreement or to any benefits that may arise therefrom.
9. The exchange of all firearms must be in compliance with all state and local law enforcement regulations related to the acquisition of firearms. Upon consummation of this Agreement, the National Park Service shall not be liable for any action related to the use of firearms described within the Agreement.
10. The National Park Service will pay all costs of transporting and insuring the objects listed on Attachment 2 to _____ (address).

Figure 6.11a. Exchange Agreement (Sample)

Exchange Agreement (Continued)

11. The parties agree that the physical transfer of all objects covered by this Agreement will occur on or before _____ (date) and that time is of the essence to this Agreement. If _____ (other party) fails to deliver the objects listed on Attachment 1 to the agreed-upon place of delivery by the date given in this paragraph, the National Park Service may, at its option, terminate this Agreement, recover any objects which it may have delivered pursuant to this Agreement and sue for damages for undue delay of the performance of this Agreement or for specific performance of this Agreement. _____ (NPS unit) remedies hereunder are not exclusive and _____ (NPS unit) retains the right to pursue any and all legal remedies available to it for the breach of this Agreement.
12. Catalog information on all NPS objects incorporated under this Agreement is included by reference to the NPS catalog number listed on Attachment 2.

For the NATIONAL PARK SERVICE (Receiving):

Recommended: _____
(Park Curator) (Date)

Approved: _____
(Superintendent) (Date)

For the other PARTY

Name: _____

Approved: _____
(Date)

Approved: _____
(Date)

Address: _____

Telephone: _____ FAX: _____

Figure 6.11b. Exchange Agreement (Continued) (Sample)

Repatriation Agreement

The Native American Graves Protection and Repatriation Act of 1990 (NAGPRA) provides definitions and procedures for the repatriation of certain Native American human remains and cultural items, as defined in 25 U.S.C. 3001-3013, in the possession of federal agencies and museums that receive federal funds to lineal descendants, Indian tribes, and native Hawaiian organizations; and

The representatives of the National Park Service _____ [NPS unit] have engaged in consultation with representatives of _____ [The TRIBE] to determine the applicability of these definitions and procedures to objects currently in the possession of the National Park Service _____ [NPS unit].

The National Park Service _____ [NPS unit] and _____ [The TRIBE] do hereby agree to the following:

1. That _____ [The TRIBE] is recognized as eligible for the special programs and service provided by the United States to Indians because of their status as Indians, and thus has status to make a claim for repatriation under NAGPRA;
2. That all cultural items described on the attached list meet the criteria outlined in the Native American Graves Protection and Repatriation Act of 1990 (25 USC 3001-3013) and 43 CFR 10.2 (b), such that:
 - a. all *human remains* are of Native American ancestry and do not include remains or portions of remains freely given by the individual from whose body they were obtained;
 - b. all *funerary objects* are known or reasonably believed to have been placed intentionally at the time of death or later with or near individual human remains;
 - c. all *sacred objects* are specific objects needed by traditional Native American religious leaders for the current practice of traditional Native American religions by their present-day adherents;
 - d. all *objects of cultural patrimony* have ongoing historical, traditional, or cultural importance central to _____ [The TRIBE], rather than to an individual tribal member and, as such, may not be alienated, appropriated, or conveyed by an individual Tribal member; and such object shall have been considered inalienable at the time the object was separated from _____ [The TRIBE];
3. That all cultural items described on the attached inventory were produced or used by an identifiable earlier group;
4. That evidence exists of a shared group identity that can be reasonably traced between _____ [The TRIBE] and the earlier group;
5. That a Notice of Inventory Completion concerning the human remains or associated funerary objects, or a Notice of Intent to Repatriate concerning unidentified funerary objects, sacred objects or objects of cultural patrimony described on the attached list has been published in the *Federal Register*. In the time since that publication [at least thirty days] neither the National Park Service _____ [NPS unit] nor _____ [The TRIBE] has become aware of any competing claim;
6. That, effective on the date of execution of this Repatriation Agreement, the National Park Service _____ [NPS unit] transfers to _____ [The TRIBE] all responsibility associated with the items described on the attached inventory.
7. That this Repatriation Agreement releases the National Park Service from any future claims by _____ [The TRIBE] regarding the objects described on the attached inventory.

Figure 6.12a. Repatriation Agreement (Sample)

Repatriation Agreement (Continued)

Signatures

This agreement shall become binding upon its execution by the authorized representative of each party. Each party warrants that it has the requisite authority to execute, deliver, and consummate the transactions contemplated by this agreement.

For the NATIONAL PARK SERVICE:

Recommended: _____
Curator Signature Date

S0 Curator [Please print] Signature Date

S0 Archeologist [Please print] Signature Date

S0 Ethnographer [Please print] Signature Date

Approved: _____
Superintendent [Please print] Signature Date

NPS Unit: _____

Address: _____

Telephone: _____ FAX: _____

For the TRIBE:

Approved: _____
Official Representative or
Lineal Descendant [Please print] Signature Date

Title Tribe/Organization

Address: _____

Telephone: _____ FAX: _____

Follow-up Contact: _____ Telephone: _____
Name [Please print]

FAX: _____

Figure 6.12b. Repatriation Agreement (Continued) (Sample)

Conveyance Agreement

Conveyance To:

Name:
Address:
(Box Number or Street)

(City, State, Zip)

Telephone: _____

FAX Number: _____

The National Park Service hereby unconditionally conveys to the above recipient, for the recipient's unrestricted use, the item(s) listed below. The National Park Service relinquishes any and all claims to the item(s) listed below.

The National Park Service certifies that the National Park Service holds free and clear title and associated rights, including copyright, to the subject property and that the National Park Service may dispose of the subject property in any manner that it may determine.

Description (or see attached list):

Park Name:

Park Address:
(Box Number or Street)
(City, State, Zip)

FAX Number: _____

Superintendent: _____ Date: _____
Print Name Signature

The recipient certifies that the recipient is a (check one): _____ Date: _____

- private institution exempt from Federal taxation under sections 501(c)(3) of the Internal Revenue Code of 1986 dedicated to the preservation and interpretation of natural or cultural heritage and qualified to manage museum collections
- non-Federal government entity, dedicated to the preservation and interpretation of natural or cultural heritage and qualified to manage museum collections

The recipient hereby acknowledges receipt of and accepts the above museum property.

Accepted By: _____
(Name and Title of Responsible Official, Please Print)

Signature of Responsible Official: _____ Date: _____

Figure 6.13. Conveyance Agreement (Form 10-99)

Collections Advisory Committee Procedures

Committee Purpose

In keeping with National Park Service policies for preserving and protecting cultural and natural resources, (park name) has established a collections advisory committee to review the following types of deaccessions from the park's museum collection:

- transfers to non-DOI federal agencies
- conveyances (donations)
- exchanges outside DOI (excluding exchange of natural history specimens)
- voluntary destruction/abandonment of museum objects

The committee will advise the superintendent regarding the appropriateness of deaccessions and dispositions. The committee will be guided by the NPS policies and procedures set forth in the *Museum Handbook*, Part II, Chapter 6, Deaccessioning. Establishment of this committee should ensure that the above deaccession transactions are fair, open, and in the best interests of the public.

Committee Structure

Policy requires that the collections advisory committee at (park name) will consist of a minimum of two members. One member will be a curator at or above the GS-11 level. The other members of the committee will not be under the supervision of the curator. No maximum number of members is required on the committee. Members may be from outside the park, but all members must be federal employees. The superintendent will choose other members of the committee from park or center resource and interpretation specialists. Individuals who aren't federal employees may be consulted on a case by case basis, as necessary.

The superintendent will select which members of the committee will review a particular deaccession and appoint a lead committee member. The size of the committee may vary, depending on the subject matter and the complexity of the deaccession(s), but each review must involve the curator (GS-11 or higher) and one other member.

Committee Members

The collections advisory committee at (park name) will consist of the following specialists:

- Curator (Lead)
- Archeologist
- Chief Interpreter
- Cultural Resource Specialist

Committee Procedures

The committee meets as needed. The lead committee member distributes copies of the deaccession package(s) to other members, including non-federal individuals who aren't on the committee. The lead committee member schedules the meeting and documents the meeting (date, location, names of attending members). He or she attaches each committee member's review comments, and the comments of non-federal specialists, to the deaccession package and forwards it to the superintendent.

Each member receives a copy of the deaccession package(s) for review prior to the meeting. Members should be familiar with Chapter 6, Deaccessioning, in the *Museum Handbook*, Part II. Committee members may consult with subject matter specialists who are not on the committee regarding specific actions. Each committee member must record his or her comments on the review form and document any consultations with other specialists. The lead committee member forwards the comments to the superintendent.

Superintendent

Date

Figure 6.14. Collections Advisory Committee Procedures (Sample)

Specialist Review

Your comments here (or attached) show that you have reviewed the proposed deaccession for conformity with the laws authorizing NPS deaccessions and the deaccessioning guidelines in the Museum Handbook, Part II, Chapter 6, Deaccessioning, and have given your best professional advice about this transaction

Description of Proposed Deaccession:

Deaccession Type:

Disposition Type:

Comments (attach additional comments if necessary):

Deaccession Recommended: Yes _____ No _____

Disposition Recommended: Yes _____ No _____

Name: _____ Title: _____

Signature

Date

Figure 6.15. Specialist Review Form (Sample)

Appendix A: Mandates and Standards for NPS Museum Collections

	<u>Page</u>
A. Overview	A:1
B. Laws, Regulations, and Conventions – NPS Cultural Collections	A:1
Laws related to NPS cultural collections	A:1
Regulations related to NPS cultural collections.....	A:4
International conventions related to NPS cultural collections.....	A:5
Contacts for laws, regulations, and conventions – NPS cultural collections	A:6
C. Laws, Regulations, and Conventions – NPS Natural History Collections	A:6
Laws related to NPS natural history collections	A:6
Regulations related to NPS natural history collections.....	A:8
International conventions related to NPS natural history collections.....	A:8
Contacts for laws, regulations, and conventions – NPS natural history collections	A:9
D. Policies and Standards	A:9
Governmentwide and departmental policies and standards related to NPS museum collections.....	A:9
NPS management policies for museum collections	A:10
NPS Director’s Orders and guidance for museum collections.....	A:14
E. List of Figures	A:17

APPENDIX A: MANDATES AND STANDARDS FOR NPS MUSEUM COLLECTIONS MANAGEMENT

A. Overview

In this appendix you will find information on:

- appropriate laws, regulations, and conventions related to NPS museum collections
 - governmentwide and departmental standards related to NPS museum collections
 - NPS management policies and servicewide standards for museum collections
 - mandates and policies for NPS integrated pest management programs
-

B. Laws, Regulations, and Conventions – NPS Cultural Collections

1. *Laws related to NPS cultural collections*

These laws provide the legal mandates for NPS management of museum collections.

- Act for the Preservation of American Antiquities, June 8, 1906 (“The Antiquities Act”) (16 USC 431-433):
 - authorizes the President to declare national monuments to protect sites and objects
 - authorizes federal departments to grant permits for survey and excavation and to enforce protection of archeological sites and objects under their jurisdiction
 - requires that excavated materials be permanently preserved in public museums
- Organic Act of 1916 (16 USC 1 et seq.):
 - authorizes the creation of the National Park Service
 - states that the mission of the NPS is “...to conserve the scenery and the natural and historic objects...therein and to provide for the enjoyment of the same in such a manner and by such means as will leave them unimpaired for the enjoyment of future generations”
- Historic Sites Act of 1935 (16 USC 461-467) authorizes the Secretary of the Interior through NPS:
 - to preserve and maintain objects of national historical or archeological significance
 - to establish and maintain museums
- Museum Properties Management Act of 1955, as amended (16 USC, Sect. 18 [f]) authorizes the Secretary of the Interior through NPS:

- to acquire collections through donation, bequest, and purchase and through transfer from other federal agencies
- to exchange collections
- to accept and make loans of museum collections
- to deaccession collections by transfer to qualified federal agencies, conveyance (donation) to qualified tax exempt private institutions and non-federal governmental agencies, and destruction

See Figure A.1 for the complete text of this law.

- Reservoir Salvage Act of 1960, as amended (16 USC 469 - 469C):

provides for the recovery and preservation of “historical and archeological data (including relics and specimens)” that might be lost or destroyed as a result of the construction of dams and reservoirs.

- Archeological and Historic Preservation Act of 1974 (16 USC 469-469C):

extends the application of the Reservoir Salvage Act of 1960 to recover and preserve “historical and archeological data (including relics and specimens)” that might be lost or destroyed as a result of any federal construction project or federally-licensed activity or program.

- National Historic Preservation Act of 1966, as amended (16 USC 470 - 470t, Sect. 110):

directs the Secretary of the Interior to issue regulations that ensure that significant prehistoric and historic artifacts, and associated records, subject to Section 110 of this Act, the Reservoir Salvage Act (as amended), and the Archaeological Resources Protection Act are deposited in an institution with adequate long-term curatorial capabilities.

- Archaeological Resources Protection Act of 1979 (ARPA) (16 USC 470aa-mm):

- defines archeological resources as any material remains of human life or activities that are at least 100 years of age, and which are capable of providing scientific or humanistic understandings of past human behavior, cultural adaptation, and related topics through the application of scientific or scholarly techniques
- requires that a permit be obtained before conducting archeological studies on public and Indian lands
- requires that information on the nature and location of resources on public and Indian lands remain confidential if its release may harm the resources
- establishes civil and criminal penalties for the excavation, removal, or damage of resources on public and Indian lands without a permit (materials lawfully acquired prior to the passage of the law are not subject to the penalties)

- requires that materials excavated from public lands and Indian lands and associated records be preserved in a suitable repository
- gives the Secretary of the Interior authority to issue regulations for the proper curation of federally-owned and administered archeological collections
- American Indian Religious Freedom Act of 1978 (42 USC 1996):
 - reaffirms the constitutional right of “freedom to believe, express, and exercise the traditional religions of the American Indian, Eskimo, Aleut, and Native Hawaiians, including but not limited to access to sites, use, and possession of sacred objects, and the freedom to worship through ceremonials and traditional rites”
- Native American Graves Protection and Repatriation Act of 1990 (NAGPRA) (25 USC 3001-13):
 - states that lineal descendants or culturally affiliated Indian tribes or Native Hawaiian Organizations may claim ownership or control of Native American human remains, funerary objects, sacred objects, and objects of cultural patrimony that are excavated or discovered on federal or tribal lands after passage of the law
 - establishes criminal penalties for trafficking in remains or objects obtained in violation of the law
 - requires federal agencies and museums that receive federal funding to inventory Native American human remains and associated funerary objects in their possession or control and identify their cultural and geographical affiliations within 5 years
 - requires federal agencies and museums that receive federal funding to prepare summaries of information about Native American unassociated funerary objects, sacred objects, or objects of cultural patrimony within 3 years

Note: The inventories and summaries provide for repatriation of items when lineal descendants or Native American groups request it.
- National Parks Omnibus Management Act of 1998 (16 USC 5937) Sec. 5937:
 - establishes the confidentiality of sensitive information regarding certain types of museum objects and other resources
 - mandates a program of inventory and monitoring for NPS resources
 - allows the withholding of information (in response to a Freedom of Information Act request) on the nature and specific location of resources (specimens) that are endangered, threatened, rare, or commercially valuable, mineral or paleontological, and of objects of cultural patrimony

2. *Regulations related to NPS cultural collections*

The following regulations include major requirements for NPS museum collections management. Many other regulations may apply in specific situations.

- 43 CFR Part 3 “Preservation of American Antiquities” (implementing regulations for the Antiquities Act):
 - authorizes federal land managers to seize materials recovered illegally from archeological resources located on federal lands
 - directs federal land managers to dispose of seized materials by depositing them in the proper national depository or by other means
 - requires that every collection recovered under the Antiquities Act be preserved in the public museum designated in the Antiquities Act permit, and be accessible to the public
 - states that the Secretary of the Smithsonian Institution must approve in writing the removal (deaccession) of an Antiquities Act collection
 - mandates that deaccessioned Antiquities Act collections must be transferred to another public museum
 - requires that an Antiquities Act collection revert to the national collections whenever a museum holding such collections ceases to exist
- 43 CFR Part 7 “Protection of Archeological Resources: Uniform Regulations”:
 - requires that repositories proposed by ARPA permit applicants to certify in writing their willingness to assume curatorial responsibility for the collections
 - requires that, for resources located on public lands, repositories must certify that they will safeguard and preserve the collections as property of the United States
 - requires that ARPA permit applicants certify that, not later than 90 days after the final report is submitted to the federal land manager, the collections will be delivered to the repository named in the ARPA permit
 - requires that federal land managers specify in ARPA permits the name of the repository in which collections are to be deposited
 - states that archeological resources excavated or removed from public lands remain the property of the United States
 - states that archeological resources excavated or removed from Indian lands remain the property of the Indian or Indian tribe having rights of ownership over such resources
 - authorizes the Secretary of the Interior to issue regulations for the curation of federally-owned and administered collections. In the absence of such regulations Federal land managers are authorized to provide for the exchange of collections among suitable repositories
 - restates the confidentiality requirement specified in ARPA
- 36 CFR Part 79 “Curation of Federally-Owned and Administered Archeological Collections”:

- states the responsibilities of federal agencies to manage and preserve collections
- identifies methods for federal agencies to use to secure and fund curatorial services
- states terms and conditions for federal agencies to include in contracts, memoranda, agreements, and other written instruments with repositories for curatorial services
- establishes standards for federal agencies to use to determine when a repository has the capability to provide long-term curatorial services
- provides guidelines for collections use
- specifies procedures and guidelines for conducting periodic inspections and inventories of collections

3. *International Conventions related to NPS cultural collections*

The following international convention applies to NPS cultural collections.

- 1970 UNESCO Convention on the Means of Prohibiting and Preventing the Illicit Import, Export, and Transfer of Ownership of Cultural Property (implemented in the United States by P.L. 97-446 in 1983, 19 USC 2601). Signatory nations agree to work to prevent the import of and trade in archeological and ethnographic materials (when requested) and in stolen cultural collections. This convention:
 - was ratified by the United States and 90 other nations by 2000.
 - provides protection for archeological and ethnographic materials when the home nation requests that other signatories not import these materials. (As of 2000, Bolivia, Cambodia, Canada, Cyprus, El Salvador, Guatemala, Mali, and Peru have had such requests approved.)
 - provides protection for stolen property, including cultural and natural history collections, that have been taken from a museum or public institution (including churches, monuments, and archeological sites) To be covered, the materials must have been previously inventoried as part of the institution's collection.
 - exempts objects imported for temporary exhibits

Note: The United States and France are the only major art-importing countries to sign the convention to date; Canada, Korea, and Australia are also signatories. It is enforced in the United States by the Customs Service.

4. *Contacts for laws, regulations, and conventions – NPS cultural collections*

Direct questions relevant to laws and regulations about cultural collections to the regional/support office (SO) curator, the regional archeologist, historian, archivist, and ethnographer.

For information on the 1970 UNESCO Convention on the Means of Prohibiting and Preventing the Illicit Import, Export, and Transfer of Ownership of Cultural Property, contact:

Cultural Property Advisory Committee
United States Department of State

SA 44, Room 247
Washington, DC 20547
Telephone: 202-619-6612
Fax: 202-619-5177
Email: culprop@usia.gov
<http://exchanges.state.gov/education/culprop>

C. Laws, Regulations, and Conventions – NPS Natural History Collections

1. *Laws related to NPS natural history collections*

These laws relate to NPS natural history collections.

- Lacey Act of 1900 (18 USC 43-44):
 - makes the violation of any state, federal, or foreign wildlife law a federal offense
 - places stipulations on the importing and labeling of wildlife and their parts
 - poses complex problems for museums in relation to the acquisition and deaccession of wildlife materials and the sale of wildlife materials in museum shops because it is hard to prove the legal history of such pieces
 - requires proof of intentional violation for enforcement, but ignorance of the relevant state, federal, or foreign statutes is not excusable.

Note: The Black Bass Act of 1930 (16 USC 851) added fish to the list of wildlife under the Lacey Act.

- Migratory Bird Treaty Act of 1918 (16 USC 703-711):
 - protects birds flying between the United States and Canada, Mexico, and Japan
 - covers all wild, native birds not legally hunted by state law
 - clarifies that some non-native species may be covered by state law and, therefore, by the Lacey Act
 - makes it illegal to kill, capture, collect, possess, buy, sell, ship, import, or export listed species including their parts, nests, and eggs
 - allows museums and non-commercial institutions to get permits for legal possession, collection, and transportation of objects, but permits impose extensive record-keeping requirements
 - states that only museums and other specified institutions can purchase any protected bird or part thereof, and the seller must possess a federal permit for a legal sale
- Bald Eagle Protection Act of 1940 (16 USC 668a), amended in 1962 to include golden eagles:
 - prohibits taking, buying, selling, trading, possession, importation or exportation of eagles or their parts, nests, eggs, or products made of

them

- authorizes permits for taking, possessing, and transporting eagles and their parts for scientific, exhibition, and Native American religious purposes
- exempts possession and transportation of eagles held prior to the law
- requires permits for any materials acquired by museums after the law was established
- Marine Mammal Protection Act of 1972 (16 USC 1361-1407):
 - places a moratorium on the killing of marine mammals by United States citizens
 - restricts the possession, sale, purchase, importation, or transportation of the animals and their products and parts
 - requires permits for exhibiting marine mammals and their parts and for holding them in storage.
 - allows Native peoples to use such parts for the manufacture and sale of handcrafts as long as the sale is handled by a licensed dealer
 - exempts museums from permit requirements for pre-Act materials or to purchase legitimate handcrafts, although they should consider getting permits for all other marine mammal materials.
- Endangered Species Act of 1973, as amended (16 USC 1531-1543):
 - prohibits harassing, harming, or killing listed species
 - prohibits the purchase, sale, or use of listed species or parts thereof in the course of an interstate commercial activity. Intra-state transactions are allowed if pre-Act ownership can be proven.
 - doesn't apply to fossils and objects greater than 100 years old, but age must be verified
 - requires park museums to have a permit to purchase more recent objects that contain parts of endangered or threatened species
 - allows gifts of endangered or threatened specimens to museums if there is proof of pre-Act ownership and if the objects have not been offered for sale since the date of this law.
 - allows loans or gifts between educational institutions. In such instances permits are not required, even if the objects cross state lines.

2. *Regulations related to NPS natural history collections*

The following regulations apply to NPS museum collections.

- 36 CFR, Section 2.5 (Revision effective April 30, 1984), "Research Specimens" Section 2.5(g) states: "Specimen collection permits shall contain the following conditions:
 - Specimens placed in displays or collections will bear official National Park Service museum labels and their catalog numbers will

be registered in the National Park Service National Catalog.

- Specimens and data derived from consumed specimens will be made available to the public and reports and publications resulting from a research specimen collection permit shall be filed with the superintendent.”

Note: A revision to 36 CFR 2.5 is in progress.

- 50 CFR, Sections 17.11 and 17.12, “Endangered and Threatened Wildlife and Plants.” These annually revised sections provide lists of names of all the species of wildlife and plants determined to be endangered or threatened.

3. *International conventions related to NPS natural history collections*

The following international convention applies to NPS natural history collections.

- Convention on International Trade in Endangered Species of Wild Fauna and Flora (CITES):
 - protects endangered species of plants and animals by regulating imports and exports
 - was ratified by the United States in 1974, and by 150 other nations by 2000
 - allows for certificates of exemption for the import or export of items acquired before CITES, and for non-commercial exchange between institutions
 - is enforced in the United States by the Fish and Wildlife Service
 - includes three appendices that protect materials of varying degrees of scarcity:

Appendix I. Species are in danger of extinction and there is no commercial trade in them. Any international transport of these materials requires permits from both the exporting and importing nations.

Appendix II. Species require strict regulation to prevent the danger of extinction and/or look like Appendix I species. Permits for international transport are issued by the exporting nation, and are allowed for any purpose not detrimental to the species.

Appendix III. Species are protected only within their native countries. They require permits for export even if they are plentiful elsewhere.

4. *Contacts for laws, regulations, and conventions – NPS natural history collections*

Direct questions relevant to the Endangered Species Act, and other laws and regulations about natural history collections to the regional/support office curator and the regional chief of natural resources management (or equivalent).

For information on CITES and other wildlife laws, including procedures and applications for getting permits to have endangered or threatened wildlife and plants in a park’s museum collection, contact:

U.S. Department of the Interior
Fish and Wildlife Service
Office of Management Authority
4401 North Fairfax Drive, Room 700
Arlington, VA 22203

Tel: 703-358-2104
<<http://international.fws.gov/global/cities.html>>

CITES Secretariat
15 chemin des Anemones
1219 Chatelaine-Geneva
Switzerland

<<http://www.cites.org>>

D. Policies and Standards

1. *Governmentwide and departmental policies and standards related to NPS museum collections*

The following governmentwide and departmental policies and standards apply to NPS museum collections:

- 41 CFR 101 Federal Property Management Regulations (FPMR) prescribes regulations, policies, procedures, and delegations of authority about the management of federal property.

- Interior Property Management Regulations, *Departmental Manual* Part 410, Personal Property Management (Subpart 114-60):
 - prescribes policies, procedures, and responsibilities governing the receipt, accountability, record-keeping, management, and survey of personal property in the Department of the Interior (DOI)
 - applies to all personal property acquired by all DOI bureaus and offices
 - ensures the safeguarding of government property against waste, fraud, and abuse
 - references the management of museum collections, noting exceptions to normal property procedures. These references are summarized in Figure A.2.

- *Departmental Manual* Part 411, Museum Property Management, Chapters 1-3:
 - defines the types of museum property
 - establishes organizational responsibilities, policies, and standards for the preservation, protection, and documentation of museum property
 - establishes organizational responsibilities for developing plans to implement these policies and standards
 - identifies mandatory procedures, reports, and data

- *Departmental Manual* Part 517, Chapter 1, Pesticide Use Policy,

outlines the pesticide use policy of the Department of the Interior. It is the policy of the Department:

“To use pesticides only after full consideration of alternatives - based on competent analyses of environmental effects, safety, specificity, effectiveness, and costs. The full range of alternatives including chemical, biological, and physical methods, and no action will be considered. When it is determined that a pesticide must be used in order to meet important management goals, the least hazardous material that will meet such goals will be chosen.”

2. *NPS management policies for museum collections*

Excerpts from *NPS Management Policies* (1988) that are specifically relevant to museum objects are as follows (chapter and page references appear in parentheses). This section will be updated when the revised *Management Policies* is issued (anticipated fall 2000).

Chapter 5 - Cultural Resource Management

Inventories (Page 5:1)

“The following cultural resource inventories will be maintained for the national park system: ... (3) a National Catalog of Museum Objects encompassing all cultural and natural history objects in NPS collections.”

Preservation of Data and Collections and Protection of Research Potential (Page 5:3)

“Field data, objects, specimens, and features of structures retrieved for preservation during cultural resource research and treatment projects, together with associated records and reports, will be managed within the park museum collection. Where practical, the features of sites and structures will be left in place.”

Treatment of Museum Objects (Pages 5:9-10)

“Preservation. A museum object will be preserved in its present condition through ongoing preventive conservation if (1) that condition is satisfactory for exhibit or research, or (2) another treatment is warranted but cannot be accomplished until some future time. Interventional measures will be taken when preventive conservation measures are insufficient to reduce deterioration to a tolerable level, or when the object is so fragile as to be endangered under any circumstances. Intervention will be minimized to reduce the possibility of compromising the object’s integrity.

Restoration. A museum object may be restored to an earlier appearance if (1) restoration is required for exhibit or research purposes, (2) sufficient data exist to permit restoration with minimal conjecture, and (3) restoration will not modify the object’s known original character. Restoration will be accomplished using the techniques and materials that least modify the object and in such manner that the materials will be removable at a later time with minimal adverse effect. Restored areas will be distinguishable from original material and documented. Restoration will take into account the possible importance of preserving signs of wear, damage, former maintenance, and other historical and scientific evidence.

Reproduction. Museum objects needed for interpretive presentations will be reproduced for such use when the originals are unavailable or would be subject to undue deterioration or loss. The National Park Service will observe copyright laws with respect to reproduction.”

Acquisition, Management, and Disposition of Museum Objects (Page 5:10)

“Objects and related documentation essential to achieving the purposes and objectives of the parks will be acquired and maintained in accordance with approved Scope of Collection Statements for each park. Archeological objects systematically collected within a park and natural history specimens systematically collected within a park for exhibit or permanent retention will be managed as part of the museum collection. Museum collection management and care will be addressed at all appropriate levels of planning.

Museum objects will be acquired and disposed of in conformance with legal authorizations and current NPS curatorial procedures. The National Park Service will acquire only collections having legal and ethical pedigrees, and each park will maintain complete and current accession records to establish the basis for legal custody of the objects in its possession. Museum catalog records will be prepared by each park to record basic property management data and other documentary information for museum objects. Objects will be inventoried in accordance with current procedures.”

Historic Furnishings (Page 5:10)

“When the historic furnishings of a structure are present in their original arrangement, they will not be moved or replaced unless required for their protection or preservation, or unless the structure is designated for another use in an approved planning document. A structure may be refurnished in whole or in part if (1) its history is significantly related to a primary park theme, (2) refurnishing is the best way to interpret that history to the public, and (3) sufficient evidence of furniture design and placement exists to refurnish with minimal conjecture. Reproductions will be used only when prototypes exist to ensure the accurate re-creation of historic pieces.”

Archives and Manuscripts (Pages 5:10-11)

“Archival and manuscript collections are considered museum property and will be managed in ways that preserve them intact for the future while providing current access.

When an archival collection not owned by the National Park Service falls within a park’s approved Scope of Collection Statement, every reasonable effort will be made to acquire it if (1) an appropriate storage facility will be provided by the Park Service or a cooperating institution, (2) the facility will be staffed by at least one archivist,

curator, librarian, or other person experienced in caring for documentary materials, and (3) the collection will be made available to serious researchers under conditions that maximize both preservation and use and ensure security against theft and vandalism.

Parks will retain notes or copies of records significant to their administrative histories when they periodically ship their official records to federal record centers.”

Fire Detection and Suppression (Page 5:14)

“When warranted by the significance of a historic structure or of the museum objects in a nonhistoric structure, adequate fire detection, warning, and suppression systems will be installed. Fire-fighting personnel will be advised of any peculiarities or dangers inherent in a structure and any objects to be given priority for protection or rescue. Park personnel will receive training in fire prevention and suppression with hand-held extinguishers at historic structures and museums, and designated personnel will be trained to respond to all emergencies involving museum collections.

Smoking will not be permitted in spaces housing museum collections or in historic structures other than those adapted for modern residential and administrative uses.”

Pest Management (Page 5:14)

“The National Park Service will follow the integrated pest management approach in addressing pest problems related to cultural resources. All feasible nonchemical methods will be exhausted before resorting to the use of chemicals. Any use of pesticides for cultural resources will conform to the NPS pesticide use policy.”

Chapter 4 - Natural Resource Management

Natural Resource Collections (Page 4:4)

“Natural resource collections include nonliving and living specimens and associated field records. If placed in exhibits or retained in permanent collections, nonliving specimens and their associated field records will be cataloged into a park’s museum collection. Management standards for such collections are specified in the *Cultural Resource Management Guideline* and the *Museum Handbook*.”

Integrated Pest Management Procedures (Page 4:13)

Integrated pest management (IPM) procedures will be used to determine when to control pests and whether to use mechanical, physical, chemical, cultural, or biological means....

The choice to use a chemical pesticide will be based on a review by regional and Washington office coordinators of all other available options and a determination that these options are either not acceptable or not feasible; cost or staffing considerations alone will not be adequate justification for use of chemical control agents. Chemical pesticides that are not specifically exempt from reporting (regardless of who the applicator is) will be used only with prior approval by the

Director on an annual basis. The application of such pesticides is subject to the Federal Insecticide, Fungicide, and Rodenticide Act (7 USC 136 et seq.), Department of the Interior policies and procedures (DM 517),...Environmental Protection Agency regulations in 40 CFR, and Occupational Safety and Health Administration regulations.”

Paleontologic Resource Management (Page 4:19)

“Management actions will be taken to prevent illegal collecting and may be taken to prevent damage from natural processes such as erosion. Protection may include construction of shelters over specimens for interpretation in situ, stabilization in the field, or collection, preparation, and placement of specimens in museum collections. The localities and geologic settings of specimens will be adequately documented when specimens are collected.”

Chapter 7 - Interpretation and Education

Interpretation and Native Americans (Page 7:5)

“The National Park Service will not exhibit native American disinterred skeletal or mummified human remains or photographs or replicas of them. There will be no display of grave goods or other objects if native Americans who are culturally associated with them object to such exhibit. Associated native American tribes and groups will be consulted to determine the religious status of any object, the sacred nature of which is suspected but not confirmed, before it is exhibited or before any action is taken.”

Chapter 8 - Use of the Parks

Research and Collection Activities (Pages 8:15-16)

“Research activities by non-NPS personnel that, in the superintendent’s judgment, might disturb resources or visitors or that require the waiver of any regulation may be allowed in parks only pursuant to the terms and conditions of an appropriate permit. Scientific collecting activities that involve the removal of plants, animals, minerals, or archeological, historical, or paleontological objects will be allowed only if they are (1) proposed in conjunction with authorized research activities and (2) authorized and conducted in accordance with all applicable legislation, regulations, and guidelines....”

Chapter 9 - Park Facilities

Curatorial Facilities (Page 9:15)

“Park curatorial facilities should be adapted to the needs of each park. They may share space in visitor centers or administrative office buildings or be housed in completely separate buildings; however, incorporation with maintenance facilities should be avoided because of the heightened danger of fire, chemical spills, and similar accidents. Curatorial facilities will meet the collection’s special requirements for security, fire suppression, and environmental controls.”

Chapter 10 - Concessions Management

Merchandise and Handcrafts (Pages 10.8-9)

“Concessioners may not sell merchandise that violates conservation principles. The sale of original prehistoric or historic archeological artifacts or vertebrate paleontologic specimens is prohibited. Clearly labeled replicas of such artifacts and specimens may be sold.”

3. *NPS Director's Orders and guidance for museum collections*

Director's Orders supplement the NPS *Management Policies*. All Director's Orders are on the Web at <<http://www.nps.gov/refdesk/DOorders/>>.

*Director's Order #28:
Cultural Resource
Management*

Director's Order #28: Cultural Resource Management, is implemented through Release No. 5 of the *Cultural Resource Management Guideline* (1997). The *Cultural Resource Management Guideline* gives guidance on how to apply policies and standards. The *Cultural Resource Management Guideline* applies to museum objects and archival and manuscript collections that are housed in parks, archeological and preservation centers, and other NPS organizational units. Excerpts from this guideline follow:

Research

- Each park has an approved stand-alone Scope of Collection Statement defining the purpose and prescribing limits and use of its museum collection.
- Every museum object is accessioned as soon as it is in NPS custody and cataloged promptly thereafter. Paper museum records and ANCS+ magnetic media are kept in secure fire-resistant storage.
- All materials resulting from systematic research projects associated with an accession are housed at the same repository, except when on temporary loan for specific use elsewhere. Within that repository, objects and records composing an accession may be stored or filed separately from related objects and records to the extent required for security, fire protection, enhanced or reduced access, preservation, fiscal control, or exhibition.
- Each park has consulted with affected Native Americans on any acquisitions that involve human remains and associated funerary objects, unassociated funerary objects, sacred objects, or objects of cultural patrimony.
- Archival and manuscript collections are surveyed, appraised, accessioned, cataloged, rehoused, arranged, and described according to procedures and guidelines contained in the *Museum Handbook*, Part II, Appendix D.
- Archival and manuscript collections are arranged and described by or under the guidance of an archivist in accordance with professional standards and procedures. A preliminary finding aid is produced as described in the *Museum Handbook*, Part II, Appendix D.
- Museum objects not relevant to a park according to its SOCS are deaccessioned as permitted by current NPS procedures.
- Archeological objects and natural history specimens systematically collected within a park are deaccessioned only if lost or so deteriorated that they no longer have scientific value.
- Objects and archival and manuscript collections in a park's museum collection are made available to qualified researchers who can demonstrate a need to use them. Access is permitted under conditions

designed to ensure the security and preservation of the materials, including adequate staff supervision. Copyright is respected in accordance with guidance in the *Museum Handbook*, Part I, Chapter 2; the *Museum Handbook*, Part II, Chapter 2 and Appendix D.

- Each outgoing loan is documented by an outgoing loan agreement. All loaned museum objects are cataloged unless loaned to NPS repositories for collections management and storage purposes. Conditions for preserving, handling, and shipping and an itemized list of museum objects are included in a loan agreement.

Planning

- Plans for park management, development, exhibits, interpretation, and research address the proper documentation, protection, preservation, and use of objects.
- Each park and center has a collection management plan to guide proper management and care of its museum collection and a separate collection storage plan if necessary.
- Each park and center has one or more collection condition surveys to detect problems with the condition of museum objects and determine conservation treatment priorities.
- Proposals for environmental control measures in historic structures are based on data from environmental monitoring for at least one year.
- Each park ensures that the cataloging and curation of objects, specimens, and associated records recovered from archeological and scientific projects are accomplished.
- Each park ensures that approved museum plans and reports are entered in the Cultural Resources Management Bibliography (CRBIB).

Stewardship

- Each park and center has identified threats to the security and protection of its museum collection and has taken appropriate measures to deal with them, including emergency planning.
- Each park and center has implemented a preventive conservation program whereby museum objects are exhibited, handled, and stored with sensitivity to their specific environmental needs and vulnerabilities and are regularly inspected for evidence of deterioration.
- Preservation and use of museum objects accords with Director's Order #24: NPS Museum Collections Management; the *Museum Handbook*, Part I; and National Archives and Records Administration standards.
- Conservation treatment required to stabilize or restore museum objects entails the least intervention necessary to satisfy treatment goals.
- Inventories of museum objects and status reports on collections are completed and submitted in accordance with current NPS museum property procedures and other administrative requirements.
- Any use of museum objects likely to damage them or hasten their

deterioration is undertaken only after careful review and approval.

*Director's Order #24: NPS
Museum Collections
Management*

Director's Order #24: NPS Museum Collections Management, gives requirements for managing park museum collections. It is supplemented by the *Museum Handbook*, Parts I-III. Director's Order #24 is reprinted in full in Figure A.3.

E. List of Figures

Figure A.1.

Museum Properties Act of 1955 as Amended November 12, 1996

Figure A.2.

References to Museum Collections Management in Interior Property
Management Regulations

Figure A.3.

Director's Order #24: NPS Museum Collections Management

16 USC Sec. 18f Management of museum properties

The purpose of this section and sections 18f-2 and 18f-3 of this title shall be to increase the public benefits from museums established within the individual areas administered by the Secretary of the Interior through the National Park Service as a means of informing the public concerning the areas and preserving valuable objects and relics relating thereto. The Secretary of the Interior, notwithstanding other provisions or limitations of law, may perform the following functions in such manner as he shall consider to be in the public interest:

- (a) Donations and bequests—Accept donations and bequests of money or other personal property, and hold, use, expend, and administer the same for purposes of this section and sections 18f-2 and 18f-3 of this title;
- (b) Purchases—Purchase museum objects, museum collections, and other personal properties at prices he considers to be reasonable;
- (c) Exchanges—Make exchanges by accepting museum objects, museum collections, and other personal properties, and by granting in exchange therefore museum property under the administrative jurisdiction of the Secretary which is no longer needed or which may be held in duplicate among the museum properties administered by the Secretary, such exchanges to be consummated on a basis which the Secretary considers to be equitable and in the public interest;
- (d) Accepting loans of museum objects—Accept the loan of museum objects, museum collections, and other personal properties and pay transportation costs incidental thereto, such loans to be accepted upon terms and conditions which he shall consider necessary; and
- (e) Making loans of museum objects—Loan to responsible public or private organizations, institutions, or agencies, without cost to the United States, such museum objects, museum collections, and other personal property as he shall consider advisable, such loans to be made upon terms and conditions which he shall consider necessary to protect the public interest in such properties.

Sec. 18f-1. [Does not apply to the National Park Service.]

Sec. 18f-2. Additional functions

- (a) Museum objects and collections—In addition to the functions specified in section 18f of this title, the Secretary of the Interior may perform the following functions in such manner as he shall consider to be in the public interest:
 - (1) Transfer museum objects and museum collections that the Secretary determines are no longer needed for museum purposes to qualified Federal agencies, including the Smithsonian Institution, that have programs to preserve and interpret cultural or natural heritage, and accept the transfer of museum objects and museum collections for the purposes of this section and sections 18f and 18f-3 of this title from any other Federal agency, without reimbursement. The head of any other Federal agency may transfer, without reimbursement, museum objects and museum collections directly to the administrative jurisdiction of the Secretary of the Interior for the purpose of this section and sections 18f and 18f-3 of this title.
 - (2) Convey museum objects and museum collections that the Secretary determines are no longer needed for museum purposes, without monetary consideration but subject to such terms and conditions as the Secretary deems necessary, to private institutions exempt from Federal taxation under section 501(c)(3) of title 26 and to non-Federal governmental entities if the Secretary determines that the recipient is dedicated to the preservation and interpretation of natural or cultural heritage and is qualified to manage the property, prior to any conveyance under this subsection.
 - (3) Destroy or cause to be destroyed museum objects and museum collections that the Secretary determines to have no scientific, cultural, historic, educational, esthetic, or monetary value.
- (b) Review and approval—The Secretary shall ensure that museum collections are treated in a careful and deliberate manner that protects the public interest. Prior to taking any action under subsection (a) of this section, the Secretary shall establish a systematic review and approval process, including consultation with appropriate experts, that meets the highest standards of the museum profession for all actions taken under this section.

Sec. 18f-3. Application and definitions

- (a) Application—Authorities in this section and sections 18f and 18f-2 of this title shall be available to the Secretary of the Interior with regard to museum objects and museum collections that were under the administrative jurisdiction of the Secretary for the purposes of the National Park System before November 12, 1996, as well as those museum objects and museum collections that may be acquired on or after November 12, 1996.
- (b) Definitions—For the purposes of this section and sections 18f and 18f-2 of this title, the terms “museum objects” and “museum collections” mean objects that are eligible to be or are made part of a museum, library, or archive collection through a formal procedure, such as accessioning. Such objects are usually movable and include but are not limited to prehistoric and historic artifacts, works of art, books, documents, photographs, and natural history specimens.

Figure A.1. Museum Properties Act of 1955 as amended November 12, 1996

114-60.100(b)	All museum property is accountable with no dollar threshold.
114-60.100(e)	Museum property is not capitalized.
114-60.100(n)	Definition of museum property
114-60.100(bb)	Sensitive property shall, at a minimum, include firearms...
114-60.200(a)	(1)...museum property will not be controlled in a general ledger control account. All items in a museum collection will be controlled through accessioning and cataloging.
114-60.401(c)	All museum property is controlled through accessioning and cataloging, regardless of value.
114-60.503(e)	An Accession Receiving Report will be used to document receipt of museum property.
114-60.601(b)	Because permanent marking of museum property is potentially damaging, items of museum collections are exempted from the marking requirements of this subpart. Bureaus and offices having museum collections will develop and implement procedures: (NPS procedures are outlined in the NPS <i>Museum Handbook</i> , Part II).
114-60.802-1(a)	A Certificate on Unserviceable Property will not be issued for...museum property.
114-60.811-2(f)	Examples of property irregularities include...loss or theft of a firearm or weapon.

Figure A.2. References to Museum Collections Management in Interior Property Management Regulations, *Departmental Manual Part 410, Personal Property Management (Subpart 114-60)*



United States Department of the Interior

NATIONAL PARK SERVICE

1849 C Street, N.W.

Washington, D.C. 20240

DIRECTOR'S ORDER #24: NPS MUSEUM COLLECTIONS MANAGEMENT

Approved: Mary H. Romer
Director

Effective Date: 9-03-08

Duration: Until amended or rescinded.

This Director's Order supersedes Director's Order #24 issued August 21, 2000. It supplements NPS *Management Policies* and is augmented by procedures in the *Museum Handbook*.

1. Background and Purpose

The National Park Service is custodian in perpetuity of irreplaceable and priceless museum collections that include objects, specimens, and archival and manuscript materials (textual, electronic, cartographic, architectural, and audio-visual documents), representing cultural and natural resources in the United States, including but not limited to the disciplines of archeology, biology, ethnology, geology, history, and paleontology. NPS museum collections are park resources that are part of the natural and cultural heritage of the country and are collected, preserved, and interpreted for public benefit.

NPS museum collections inform and enhance every aspect of the NPS mission, from resource management and interpretation, to research and public accountability. Featured in exhibits, interpretation and education programs, films, and print and electronic publications, NPS museum collections are key resources for educators, students, researchers, park managers, park neighbors, and the general public. Accessibility of museum collections is a prime component of museum management.

The NPS *Management Policies* lay the foundation by which the NPS meets its responsibilities toward these museum collections. This Director's Order provides further policy guidance, standards, and requirements for preserving, protecting, documenting, and providing access to, and use of, NPS museum collections.

2. Authority for this Director's Order

Authority for issuing this Director's Order is found in 16 U.S.C. 1 through 4, and delegations of authority contained in Part 245 of the Department of the Interior Manual. Additional key related authorities are found in the Antiquities Act of 1906 (16 U.S.C. 431-433), the Historic Sites Act

of 1935 (16 U.S.C. 461-467), the Management of Museum Properties Act¹ of 1955, as amended (16 U.S.C. 18f, and 18f2-3), the National Historic Preservation Act of 1966, as amended (16 U.S.C. 470 et seq.), the Archaeological Resources Protection Act of 1979 (16 U.S.C. 470aa-mm), the Native American Graves Protection and Repatriation Act of 1990 (25 U.S.C. 3001), the National Parks Omnibus Management Act of 1998 (16 U.S.C. 5901 et seq.), and the Departmental Manual 411 DM, Managing Museum Property.

This order is intended only to improve the internal management of the NPS and is not intended to, and does not, create any right or benefit, substantive or procedural, enforceable at law or equity by a party against the United States, its departments, agencies, instrumentalities or entities, its officers or employees, or any other person.

3. Objectives

The objectives of this Director's Order, in conjunction with the accompanying *Museum Handbook*, are to:

- Ensure that NPS managers and staff have information on the standards and actions for successfully and ethically complying with NPS *Management Policies* on museum collections.
- Provide a means of measuring and evaluating progress in preserving, protecting, documenting, accessing, and using museum collections.

4. Responsibilities

4.1 Associate Director, Cultural Resources

The Associate Director, Cultural Resources, with the assistance of the Chief Curator and the Park Museum Management Program (PMMP), has the following responsibilities:

4.1.1 Code of Ethics: Follow the Code of Ethics for the museum management program (see 4.1.2).

4.1.2 *Museum Handbook*: Develop, issue, and periodically update a *Museum Handbook* containing the information park managers need to know to comply with laws, departmental and Service-wide policies, regulations, professional standards, and a code of ethics applicable to museum collections management. Include in the *Museum Handbook*, as a supplement to this Director's Order, specific guidance for collecting, preserving, protecting (including security and fire protection), documenting, accessing, and using museum collections, clearly distinguishing between those actions that are mandatory requirements and those that are discretionary. Cite those laws, policies, and regulations in relevant sections.

4.1.3 Strategic Plans: Develop strategic plans and goals to improve and maintain the management of NPS museum collections Service-wide, consistent with the Government Performance and Results Act of 1993 (31 USC 1115).

4.1.4 National Catalog: Maintain for management and public benefit a National Catalog of Museum Objects, consisting of electronic and paper catalog records, with accession and catalog data for all parks. Develop and maintain an automated collections management program (the Automated National Catalog System [ANCS+ and its successor]) for use by parks, centers, and offices Service-wide, as well as the general public.

4.1.5 Report Requirements and Analysis: Identify reports that are required annually, or at other times, to further museum collections management. Reporting requirements will be kept to the minimum necessary. Maintain, analyze, and report on data submitted by parks, centers, and regions, including: the Collections Management Report; the NPS Checklist for Preservation and Protection of Museum Collections; funding distributions and accomplishments; storage planning data; and other required reports and surveys. Maintain a current Service-wide museum collections storage plan based on regional storage planning data.

4.1.6 Annual Inventory: Review regional certifications of annual inventories, summarize and report certification results to the Service-wide property management officer, and take any necessary corrective action.

4.1.7 Museum Supplies, Equipment, and Technologies: Research products and facilitate park and center acquisition and use of appropriate supplies, forms, equipment, and technologies for management of museum collections.

4.1.8 Service-wide Initiatives: Develop and coordinate Service-wide initiatives, reviews, and funding to improve museum management.

4.1.9 Technical Information: Publicize and disseminate technical information on museum management, including conservation and archival collections management.

4.1.10 Information Access: Publicize NPS museum collections by developing and maintaining access to collections information through various media, including the World Wide Web and ANCS+.

4.1.11 Professional Qualifications and Training: Evaluate Service-wide professional competencies and training needs in museum management, and develop strategies, guidelines, and curricula to meet those needs. Coordinate training to address new technologies, programs, and initiatives.

4.1.12 Plan Review: Review draft park plans that receive Washington Office review, such as general management plans, for appropriate coverage of museum management.

4.1.13 Technical Assistance: Provide technical assistance and advice to park and center managers regarding acquiring, preserving, protecting, documenting, accessing, and using museum collections. Provide this assistance and advice at the request of regions.

4.2 Regional Directors and WASO Associate Directors with Museum Collections Responsibility

Regional directors (assisted by regional associate directors and regional museum support staff), and WASO associate directors accountable for museum collections, have the following responsibilities:

4.2.1 Code of Ethics: Follow the Code of Ethics for the museum management program in the *Museum Handbook*.

4.2.2 Plan and Performance Review: Use the strategic and annual performance planning processes, the park planning process, and the performance management system to ensure that superintendents and center and other managers meet their responsibilities to manage museum collections according to this directive. Review park plans for appropriate coverage of museum collections management, and to ensure consistency with NPS requirements. Review design and construction plans to ensure that museum preservation, protection, documentation (including information technology), and access requirements are met.

4.2.3 Technical Assistance: Provide technical assistance to parks and centers to assist them in meeting NPS museum management requirements, and in providing for access to and use of collections.

4.2.4 Staffing and Training: Evaluate museum management staffing and training needs, and develop and provide training to park and center staff. Regional directors will alert the Associate Director, Cultural Resources, about regional training needs that may apply Service-wide.

4.2.5 Plans, Priorities, and Reports: Develop plans and set priorities (including funding priorities) for managing museum collections based on all approved planning documents, including strategic plans, the Service-wide storage plan, and park Collection Management Plans, and information provided through Service-wide reports and requirements, including the Collections Management Report, NPS Checklist for Preservation and Protection of Museum Collections, and Automated Inventory Program. Review reports to ensure that parks and centers meet reporting requirements. Maintain current regional storage planning data, consistent with the Service-wide storage plan and standards, and submit data updates to the Associate Director, Cultural Resources.

4.2.6 Annual Inventory Certification: Annually certify to the Associate Director, Cultural Resources, Attention: Manager, PMMP, no later than **September 30** each fiscal year, that parks and centers have completed their annual inventories. Review park and center annual inventories and take any necessary corrective actions. Establish a regular schedule for parks in the region to submit the inventories. Approve exceptions to this requirement for extenuating circumstances, such as when collections are inaccessible during construction projects or after major natural disasters; or when non-NPS repositories have equivalent or more rigorous annual inventory procedures, those procedures are documented in a current repository agreement or repository loan

agreement, the repository annually reports inventory results to the parks with collections stored in the repository, and the results are reported in an addendum to the park superintendent's annual inventory certification and noted in the regional director's annual inventory certification.

4.2.7 Destructive Analysis and Consumptive Use: After careful review, if the benefits can be clearly shown to outweigh the resulting or potential damage or loss, approve destructive analysis of rare or highly significant objects, specimens, and archival items, and any consumptive use of museum collections.

4.2.8 Unconditional Gifts: Grant exceptions to the unconditional gift policy on a rare and case-by-case basis.

4.2.9 Delegation of Authority to Accept Donations: Delegate authority to accept donations of money and other personal property for the purposes of museum management to superintendents and center managers, as appropriate, and in compliance with NPS donations policy (see Director's Order #21, Donations and Fundraising).

4.2.10 Accreditation: Authorize parks to apply for accreditation by the American Association of Museums upon request from a park superintendent and recommendation of the regional curator.

4.3 Park Superintendents and Center Managers

Park superintendents, center managers, and others who manage collections (with the assistance of museum management staff) have the following responsibilities:

4.3.1 Code of Ethics: Follow the Code of Ethics for the museum management program in the *Museum Handbook*.

4.3.2 Standards: Meet museum management standards in the NPS *Museum Handbook* (Parts I-III) for:

- acquiring, preserving, protecting (including security and fire protection), documenting (including accessioning, cataloging, lending, deaccessioning), accessing, and using museum collections; and
- completing actions specific to archival and manuscript collections (appraising, arranging, describing, producing finding aids, and providing reference and duplication services).

4.3.3 Procedures: Follow procedures in the *Museum Handbook*.

4.3.4 Ongoing and Corrective Actions: Provide ongoing funding for recurring museum management functions and take appropriate action to correct identified preservation, protection, documentation, and access and use deficiencies, including programming for funding to correct such deficiencies. Complete Project Management Information System (PMIS) project statements that identify all preservation, protection, documentation,

access and use needs. Monitor projects to ensure conformance with preservation, protection, documentation (including information technology), and access policies and procedures.

4.3.5 Staffing and Training: Evaluate and address museum management staffing and training needs according to established personnel qualifications standards and Service-wide professional competencies.

4.3.6 Scope of Collection: Approve and keep current a Scope of Collection Statement to identify the scope of collecting activities and define the purpose of the collection. Ensure that the statement is consistent with natural resource and archeological permit conditions. Ensure acquisitions are consistent with the Scope of Collection Statement.

4.3.7 Collection Management Plan: Approve, keep current, and implement a Collection Management Plan to:

- evaluate issues of preserving, protecting (including security and fire protection), storing, documenting, accessing and using collections;
- address issues specific to archival and manuscript collections (appraising, arranging, describing, producing finding aids, providing reference and duplication services, and migrating electronic documents so that they remain accessible); and
- propose a strategy to address the issues, including staffing and cost estimates, consistent with park and Service-wide strategic and other planning documents, including the Service-wide storage plan.

4.3.8 Housekeeping Plan: Approve, keep current, and implement a Housekeeping Plan for every space that houses museum collections to ensure that housekeeping routines are sensitive to museum collections preservation needs.

4.3.9 Integrated Pest Management: Approve, keep current, and implement an Integrated Pest Management Plan that addresses the museum collections.

4.3.10 Emergency Operation: Approve, keep current, and implement a Museum Collections Emergency Operations Plan, as part of the park's Emergency Operations Plan and consistent with the National Incident Management System, identifying museum collection vulnerabilities to events (such as fire, earthquakes, and floods) and responses that will protect resources without endangering human health and safety. Ensure staff trains, practices, and prepares for emergency response. Assist other NPS areas and park partners, as authorized, in emergency response for museum collections. Assist other federal agencies, and tribal, state, and local governments in the event of a major disaster or emergency under the National Response Framework, Natural and Cultural Resources and Historic Properties part of Emergency Support Function #11.

4.3.11 Collections Hazards: Complete a Job Hazard Analysis (JHA) for all museum jobs that have an associated history of injury, illness, or death; or that require the use of

personal protection equipment, such as respirators; or that involve activities that are clearly dangerous, such as handling collections with mold, working with toxic or flammable chemicals, or operating heavy machinery. Notify collections users when collections may have been treated with potentially toxic substances consistent with Department of the Interior guidance at <http://www.doi.gov/museum/>.

4.3.12 Collection Condition: Monitor and record information about the environment in spaces housing collections and manage the environment to maximize preservation. Complete Collection Condition Surveys, as needed, to assess conditions in spaces housing museum collections, to record the condition of objects or groups of objects, and to determine treatment needs and priorities. Incorporate survey data in ANCS+ and in accession or catalog files.

4.3.13 Accession and Catalog Records: Accession collections upon acquisition to establish basic accountability. Catalog the collections immediately following acquisition, or have funding requests in place to catalog them in the near future. Survey, appraise, rehouse, arrange, and describe archival and manuscript collections and prepare finding aids. Develop park archival duplication and reference procedures. Have funding requests in place to address eliminating any archival processing backlog.

4.3.14 Collections Management Records Backup: Maintain a complete current backup of all electronic data at a location that is not vulnerable to the same catastrophic events as the computer workstation. In addition, submit the required annual backup to the National Catalog in Harpers Ferry, West Virginia (see 5.4).

4.3.15 Unconditional Gifts: Accept only unconditional gifts and bequests, and, where possible, obtain applicable copyrights and releases with acquisitions. Obtain regional director's approval for rare exceptions, on a case-by-case basis.

4.3.16 Project-generated Collections: Require project budgets to include funding for the initial management of collections that are project-generated. Initial collections management includes cataloging; labeling; conservation examination and treatment (including specimen preparation); housing and storage of objects and specimens; and organization and storage of project documentation, including appraisal, arrangement, description, finding aid production, and appropriate archival housing.

- Before starting, permitting, or contracting a project, specify in writing in the task directive, proposal, agreement, permit, or contract, the parties responsible, the designated NPS or non-NPS repository, the collections management tasks, and a time schedule for completion.
- Hold NPS project coordinators, permittees, and contractors responsible and verify compliance in completion reports and with park collection management staff.
- Fund subsequent ongoing maintenance costs of collections management from the operating base of the responsible park, center, or other repository.
- If project-generated collections cannot be accommodated in available or planned

storage space and new storage space is necessary, request modification of the regional storage planning data to accommodate the expanded collection. If interim storage is needed, specify in the project task directive the location of that storage, and state that it must meet NPS standards. Identify the funding source for interim storage.

- Strategically manage permit designations of and subsequent loans to non-NPS repositories to facilitate research and access while consolidating collections, as appropriate, to minimize the park's administrative workload.
- Ensure compliance with Director's Order #19, Records Management, in creation and management of resource management records.

4.3.17 Systematic Collections: Add collections made through systematic field inventory, monitoring, or research to the museum collection in accordance with collection permits and the Scope of Collection Statement. Collected materials not authorized for consumptive analysis remain federal property and will be accessioned, labeled and cataloged into the NPS cataloging system. House those collections associated with a single accession at the same repository to facilitate research and use. Superintendents may authorize housing of collections from the same accession at different repositories if by so doing preservation, research, and use will be improved. As appropriate, lend these collections for exhibit, research, conservation, and other approved uses.

4.3.18 Deaccession Records: Deaccession objects inconsistent with the Scope of Collection Statement. Complete Case Incident Reports, Reports of Survey, and deaccession actions when thefts, losses, and involuntary destruction occur. Complete deaccession actions in compliance with the Native American Graves Protection and Repatriation Act and other laws.

4.3.19 Collections Management Report: Annually complete the automated Collections Management Report (CMR) in cooperation with the PMMP (see 5.1) The report provides information on accessions, deaccessions, cataloging, backlogs of objects to be cataloged, use of museum collections, and total collection size. The report must include all collections, whether kept in park facilities, other NPS facilities, or in non-NPS repositories. Verify, sign, and file the CMR at the park by **January 15** (see 5.1).

4.3.20 Annual Inventory: Conduct an annual collection inventory on a regular schedule using the Automated Inventory Program (AIP) in ANCS+ and reconcile the results with existing accession and catalog records. Take any necessary corrective action. Certify the annual inventory and submit it to the regional director (see 4.2.6 for exceptions applicable to non-NPS repositories; and 5.3).

4.3.21 Checklist: Keep the NPS Checklist for Preservation and Protection of Museum Collections (Checklist) up-to-date in the Automated Checklist Program (ACP) in ANCS+ (see 5.1). The Checklist records information on preservation and protection conditions in parks and centers, identifies deficiencies, and provides estimated costs to correct deficiencies.

4.3.22 Conservation Treatment and Documentation: Provide conservation treatment required to stabilize or restore museum objects using the least intervention necessary to satisfy treatment goals. Document treatment of collections, record that information in ANCS+, and retain reports and documentation in accession or catalog files.

4.3.23 Cellulose Nitrate and Cellulose Ester Film: Identify cellulose nitrate and cellulose ester film, and take steps to preserve the visual information contained by duplicating the images onto polyester-based film. After inspecting the copies, evaluate and destroy the original film, or, in the case of original film with high artifactual, intrinsic, evidential, or associational value, provide for long-term storage according to the criteria in *Museum Handbook*, Part I, Appendix M, "Management of Cellulose Nitrate and Ester Film."

4.3.24 Access and Use: Promote access to cataloged collections for research, educational, and interpretive purposes through a variety of means and media, such as exhibits, interpretation and education programs, loans, publications, film and television, the World Wide Web, archival finding aid production and distribution, and posting of finding aids and repository-level guides for archival and manuscript collections in the National Union Catalog of Manuscript Collections (NUCMC).

- Ensure that access and use are consistent with the laws and NPS policies pertaining to Freedom of Information Act disclosures, copyright, privacy, publicity, obscenity and pornography, defamation, and resource protection.
- Document controlled access and use of collections and museum records with a researcher logbook, signed access policy statement, researcher registration, copyright and privacy restriction statement, and duplication forms.

4.3.25 Consultation: Consult with affiliated groups in managing collections, including Native American groups when managing collections subject to the Native American Graves Protection and Repatriation Act.

4.3.26 Preservation vs. Destructive Use: Manage objects to preserve their condition, including using reproductions when originals may be damaged by use. Authorize in writing destructive analysis of collections, except for rare or highly significant objects, specimens, and archival materials. Obtain regional director approval for destructive analysis of rare or highly significant objects, specimens, and archival materials and for any consumptive use of collections.

4.3.27 Exhibits: Exhibit collections according to an approved exhibit plan, accompanied by maintenance instructions. Ensure that all exhibits meet the standards in the NPS Checklist for Preservation and Protection of Museum Collections. Develop and implement a rotation routine for environmentally-sensitive items. Develop online exhibits to expand access to collections while protecting them from the stress of exhibit conditions.

4.3.28 Objects in Historic Structures: Document furnishings that are exhibited in their associated historic structures with an approved Historic Furnishings Report. Consider the preservation requirements of both objects and historic structures when objects are on exhibit or in storage in historic structures.

4.3.29 Exhibit of Human Remains: Never exhibit American Indian, Alaska Native, or Native Hawaiian human remains or photographs, drawings or renderings, or casts of the remains. Exhibit non-Native-American human remains and photographs, drawings or renderings, or casts of the remains only in consultation with traditionally associated groups.

4.3.30 Distribution of Approved Reports and Plans: Ensure that approved research reports, such as Historic Furnishings Reports, are distributed according to the guidance/handbook associated with Director's Order #28, Cultural Resource Management. Maintain multiple copies of approved museum plans, as needed, in the park and submit one copy of each plan (including the Scope of Collection Statement) to the regional director; Park Museum Management Program, WASO; Park Cultural Resources, Attention: CRBIB, WASO; Technical Information Center, Denver Service Center; Harpers Ferry Center Library; and NPS archeological or preservation center, as applicable. Redact any sensitive or confidential data, such as security systems or certain locality information, before distributing reports and plans that may be accessible to the general public.

4.3.31 Accreditation: Consult with the regional curator and seek approval from the regional director before applying to the American Association of Museums (AAM) for accreditation. While accredited, parks may display a modest-sized AAM accreditation logo in a public place near the museum or visitor center entrance and on the park's web site in association with information about the collections. Seeking accreditation is optional but encouraged for parks with substantial museum operations.

5. Submissions and Deadlines

5.1 Collections Management Report: Parks and centers submit, via e-mail, data on research requests and noteworthy information, including noteworthy accessions and deaccessions, for the current fiscal year by **September 15** to PMMP. Using these data and data extracted from the park's catalog records (see 5.4), the PMMP prepares the CMRs and posts them on InsideNPS on or about **October 1**. Parks and centers review the CMRs and submit any corrections, via e-mail, to PMMP. Corrections to be included in data submitted for Government Performance and Results Act (GPRA) reports and performance-based funding allocations must be submitted and accepted within one week of posting on InsideNPS. Other corrections should be submitted as soon as possible, but no later than **December 31**. Superintendents verify, print, sign and file the park's CMR by **January 15**. NPS uses CMR information for strategic planning and annual reporting, including reporting on NPS strategic operational plan Goal Ib2D consistent with GPRA.

5.2 Checklist: Parks and centers update their Checklist in the ACP by **September 15** to show changes as of the end of the current fiscal year. Parks and centers submit the Checklist as part of the National Catalog submission (see 5.4) and may update the Checklist at other times, using the ACP, by submitting it separately to the PMMP. The PMMP compiles and distributes regional and Service-wide reports. NPS uses Checklist data for strategic planning and annual reporting. Parks and PMMP use Checklist data to report on NPS strategic operational plan Goal Ia6 consistent with GPRA.

5.3 Annual Inventory: Parks and centers annually submit the inventory generated using the AIP to the regional director, according to a schedule that the region approves. The regional director certifies the completion of the inventories to the Associate Director, Cultural Resources, Attention: Manager, PMMP, no later than **September 30** each fiscal year.

5.4 National Catalog Submissions: Parks and centers annually submit to the National Catalog complete electronic backups of their ANCS+ natural history and cultural resource directories by **September 15**. The National Catalog prints and stores archival paper copies of the catalog records. The National Catalog prints and sends paper copies of catalog records to parks and centers upon request. This submission includes the Checklist (see 5.2) and data that PMMP uses to generate the park and Service-wide Collections Management Reports (see 5.1). Parks have the option to include the archives directory in the National Catalog backup. They may also submit, via the U.S. Postal Service or express carrier, a backup of images on CD.

5.5 Project Proposals and Funding Reports: In response to the Service-wide Comprehensive Budget Call, parks and centers submit museum collections project proposals in PMIS and include required museum collections program-specific information in PMIS or on optional forms. For projects funded in the previous year, by **October 31**, parks and centers provide accomplishment reports in PMIS and include required museum collections program-specific information in PMIS or on optional forms.

--- End of Director's Order ---

ⁱ Congress did not give this act a formal title. It is also known as the Museum Act.

Appendix B: Cataloging Costs

	<u>Page</u>
A. Estimating Cataloging Costs	B:1
How do I estimate the cost to catalog objects?	B:1
What variables affect cataloging costs?	B:1
How do I interpret the data in Figure B.1?	B:2
B. Funding Cataloging Costs	B:2
Where can I get funds to catalog recent acquisitions?	B:2
Where can I get funds to catalog the backlog?	B:3
Where can I get funds to recatalog the collections?	B:3
C. Applying For and Spending Cataloging Funds	B:3
How can I apply for cataloging funds?	B:3
What are some things to remember when applying for cataloging funds?.....	B:3
What are some things to remember when spending funds for cataloging?	B:3
D. List of Figures	B:5

APPENDIX B: CATALOGING COSTS

A. Estimating Cataloging Costs

1. How do I estimate the cost to catalog objects?

<i>If you...</i>	<i>Then...</i>
have cost data from a comparable cataloging project	use that data and adjust the variables to accommodate the new project
lack comparable cost data	contact other parks that have similar collections and ask for their cost data, then adjust the variables for your situation
are uncertain about the costs	use the regional or Servicewide average in Figure B.1, Recent Cataloging Costs

Figure B.1 charts provide high, low, and average cataloging costs. The charts also include costs by discipline and region, as well as Servicewide costs, for recent fiscal years.

Note: Do not use regional costs data that seems to be out of line compared with other regions' costs for that discipline. Cost data can be skewed when only a few objects are cataloged.

Approach the question of cataloging costs from two angles. Determine a rough estimate of the cost and determine the cost per item. Base cataloging cost estimates on:

- how long the work will take
- how the work will be accomplished
- the level of personnel needed to do the work
- additional costs, such as travel, materials, overhead, computer equipment, and benefits

After you determine the overall cost, divide the cost by the number of items to determine the cost per item. Use the cost per item to compare with the costs of past projects or the costs in Figure B.1. Make adjustments as appropriate.

2. What variables affect cataloging costs?

Costs for cataloging vary and depend on many factors, including the:

- expertise and skills of the staff or the contractor who will do the work
- size of the collection (for example, larger collections tend to have lower costs because of economies of scale)
- type or discipline of the material you are cataloging (for example, ethnology tends to have higher costs; archeology has relatively lower

costs)

- type or discipline of the material you are cataloging (for example, ethnology tends to have higher costs; archeology has relatively lower costs)
- complexity of the collection (for example, a collection of unorganized personal papers will take longer to catalog than a collection of organizational files that are neatly filed in original order)
- amount of lot cataloging (for example, material that you lot catalog would have lower costs than items you catalog individually)
- condition of the collection (for example, maps might need to be relaxed and unrolled before cataloging)
- amount of documentation that is needed (for example, history objects may require identification and dating; natural history specimens may already have labels that include identification)
- overhead charged by contractors and other service providers
- costs for computer equipment
- costs for materials, such as archival supplies, that are essential to the cataloging process
- travel costs, if travel is required to accomplish the cataloging

3. *How do I interpret the data in Figure B.1?*

For each discipline in each region, the charts provide a high, low, and average cost for cataloging an object. The charts also show how many objects were cataloged at that cost. Remember that there are economies of scale. Projects with few objects tend to have higher than average costs. Projects with many objects tend to have lower than average costs.

B. Funding Cataloging Costs

1. *Where can I get funds to catalog recent acquisitions?*

Projects that generate collections must fund the cataloging, preservation, and preparation of those collections for storage. Project funds may be from archeological or natural resource projects, exhibit development, historic furnishings implementation projects, historic structure stabilization projects, or other sources.

- catalog other acquisitions, such as gifts, with:
- base funds
- Cultural Resources Preservation and Protection (CRPP) funds, *or*
- Natural Resources Preservation and Protection (NRPP) Funds

2. *Where can I get funds to catalog the backlog?*

Catalog collections that are part of a pre-1987 uncataloged backlog with:

- park base funds
- Backlog Cataloging funds, *or*
- CRPP funds

Catalog post-1987 backlogs using:

- park base funds, *or*
- CRPP funds

3. *Where can I get funds to recatalog the collections?*

Park base and CRPP funds are good sources for recataloging.

C. Applying For and Spending Cataloging Funds

1. *How can I apply for cataloging funds?*

The Associate Director, Cultural Resource Stewardship and Partnerships, makes an annual call in late summer for cultural resources projects to be funded by CRPP and Backlog Cataloging. The Associate Director, Natural Resource Stewardship and Science, makes an annual call for NRPP projects. Contact the regional/support office (SO) curator for guidance in seeking funding.

2. *What are some things to remember when applying for cataloging funds?*

When you apply for cataloging funds, make sure:

- your project meets the criteria for the fund source
- your park submitted a Collections Management Report (CMR, Form 10-94) last year (see Section VIII of Chapter 4 in this handbook)
- the data on the CMR are consistent with your proposal (for example, the park has a backlog of 5,000, and you are proposing to catalog 2,500)
- the project will enter the catalog data in the Automated National Catalog System (ANCS+) or its successor
- you identify the project in the park's Resource Management Plan and Project Management Information System (PMIS)
- archives to be cataloged are archives that belong in the museum collection and **are not official records** (see Appendix D in this handbook)

3. *What are some things to remember when spending funds for cataloging?*

When you spend funds for cataloging museum collections, make sure:

- you spend the funds and accomplish the work as proposed, or submit a revision to the fund manager after consultation with the regional/SO curator

- you submit an accomplishment report to the fund manager at the end of the fiscal year
 - you submit the catalog data on disk to the National Catalog (see Chapter 3 in this handbook)
-

D. List of Figures

Figure B.1a	Recent Cataloging Costs (FY 1997)
Figure B.1b	Recent Cataloging Costs (FY 1998)
Figure B.1c	Recent Cataloging Costs (FY 1999)

2007 Appendix B

REGION		ARCHEOLOGY		ETHNOLOGY		HISTORY		ARCHIVES		BIOLOGY		PALEONTOLOGY		GEOLOGY	
		COST/ OBJECT	TOTAL OBJECTS	COST/ OBJECT	TOTAL OBJECTS	COST/ OBJECT	TOTAL OBJECTS	COST/ OBJECT	TOTAL OBJECTS	COST/ OBJECT	TOTAL OBJECTS	COST/ OBJECT	TOTAL OBJECTS	COST/ OBJECT	TOTAL OBJECTS
AK	HI	1.30	15			23.91	9	1.81	5,200						
	LOW	1.00	8,214			23.91	9	0.39	24,005						
	AVG	1.02	17,101			23.91	9	1.18	90,565						
IM	HI	2.15	3,247	10.00	1	53.57	560	2.62	9,600						
	LOW	0.55	43,990	10.00	1	1.53	5,677	0.37	81,186						
	AVG	0.89	128,840	10.00	1	8.10	6,705	0.81	155,913						
MW	HI	1.55	18,743			60.18	240	9.09	5,338		1.99	9,854			
	LOW	1.55	18,743			60.18	240	0.49	70,853		1.99	9,854			
	AVG	1.55	18,743			60.18	240	1.09	76,191		1.99	9,854			
NC	HI														
	LOW														
	AVG														
NE	HI	2.11	9,491			13.28	225	2.91	28,800						
	LOW	2.09	31,593			13.28	225	0.24	58,400						
	AVG	2.09	41,804			13.28	225	1.01	221,088						
PW	HI	1.31	1,412			23.39	135	2.67	10,580	3.28	172	16.22	3,391	1.48	25
	LOW	1.31	1,412			1.39	133	0.22	31,200	1.44	950	16.22	3,391	1.48	25
	AVG	1.31	1,412			12.36	350	0.54	613,379	1.72	1,122	16.22	3,391	1.48	25
SE	HI	7.56	2,514			24.94	55	3.14	5,768						
	LOW	0.20	151,282			2.68	1,046	0.18	119,200						
	AVG	0.68	287,834			3.52	1,477	0.60	519,015						
TOTAL	AVG	0.90	495,014	10.00	1	8.51	8,973	0.70	1,676,151	1.72	1,122	5.63	13,245	1.48	25

Figure B.1a. Recent Cataloging Costs (FY2007)

REGION		ARCHEOLOGY		ETHNOLOGY		HISTORY		ARCHIVES		BIOLOGY		PALEONTOLOGY		GEOLOGY	
		COST/ OBJECT	TOTAL OBJECTS	COST/ OBJECT	TOTAL OBJECTS	COST/ OBJECT	TOTAL OBJECTS	COST/ OBJECT	TOTAL OBJECTS	COST/ OBJECT	TOTAL OBJECTS	COST/ OBJECT	TOTAL OBJECTS	COST/ OBJECT	TOTAL OBJECTS
AK	HI	1.75	552	9.00	6	9.75	1,323	3.50	350	10.00	126			10.00	153
	LOW	0.56	13,492	9.00	6	9.00	31	1.62	49,000	7.22	551			10.00	153
	AVG	0.60	14,044	9.00	6	9.73	1,354	1.81	71,352	7.74	677			10.00	153
IM	HI	5.25	5	25.00	42	30.00	526	83.33	198			7.00	241	6.00	121
	LOW	1.00	770	25.00	42	4.49	445	0.68	19,280			7.00	241	6.00	121
	AVG	1.62	1,106	25.00	42	14.37	1,687	1.37	156,181			7.00	241	6.00	121
MW	HI	2.38	13,217					7.28	6,872			4.65	1,721		
	LOW	0.54	61,822					7.28	6,872			4.65	1,721		
	AVG	0.98	104,209					7.28	6,872			4.65	1,721		
NC	HI														
	LOW														
	AVG														
NE	HI	3.00	16,177					1.89	29,938						
	LOW	3.00	16,177					1.00	75,200						
	AVG	3.00	16,177					1.42	145,138						
PW	HI	10.00	1			20.00	104	6.97	388	20.94	573	56.56	424		
	LOW	0.67	34,400			0.61	171	0.16	238,378	1.20	20,000	13.16	4,104		
	AVG	0.67	34,713			9.11	1,507	0.52	570,303	3.20	26,070	17.22	4,528		
SE	HI	2.50	15,962			1.61	2,460	6.34	3,039						
	LOW	1.84	18,885			1.60	18	0.23	87,800						
	AVG	2.02	78,469			1.61	2,478	0.66	488,976						
TOTAL															
	AVG	1.38	248,718	23.00	48	7.85	7,026	0.85	1,438,822	3.32	26,747	13.51	6,490	8.23	274

Figure B.1b. Recent Cataloging Costs (FY2008)

REGION		ARCHEOLOGY		ETHNOLOGY		HISTORY		ARCHIVES		BIOLOGY		PALEONTOLOGY		GEOLOGY	
		COST/ OBJECT	TOTAL OBJECTS	COST/ OBJECT	TOTAL OBJECTS	COST/ OBJECT	TOTAL OBJECTS	COST/ OBJECT	TOTAL OBJECTS	COST/ OBJECT	TOTAL OBJECTS	COST/ OBJECT	TOTAL OBJECTS	COST/ OBJECT	TOTAL OBJECTS
AK	HI	1.03	9,051					1.25	2,400	4.91	3913				
	LOW	1.03	9,051					0.97	4,138	4.91	3913				
	AVG	1.03	9,051					1.21	51,336	4.91	3913				
IM	HI	0.30	5,258			11.17	2,596	1.42	2,800	2.00	124	2.53	1,504	2.00	31
	LOW	0.30	5,258			0.56	13,484	0.33	67,324	0.16	123,278	2.53	1,504	2.00	31
	AVG	0.30	5,258			2.23	16,919	0.73	340,659	0.16	123,402	2.53	1,504	2.00	31
MW	HI	2.96	10,230					6.84	7,093	12.07	944				
	LOW	0.75	31,534					2.96	5,926	12.07	944				
	AVG	1.55	57,147					5.07	13,019	12.07	944				
NC	HI														
	LOW														
	AVG														
NE	HI	3.96	12,387			16.91	2,501	6.85	3,360						
	LOW	3.96	12,387			10.16	3,504	1.35	59,200						
	AVG	3.96	12,387			12.97	6,005	1.58	177,399						
PW	HI	6.96	3,788					38.36	1,173	9.23	758	13.65	3,442		
	LOW	0.43	27,761					0.10	388,000	0.46	16,308	9.16	1,746		
	AVG	1.21	38,310					0.59	580,298	0.99	18,095	12.14	5,188		
SE	HI	2.59	1,753			23.63	677	4.60	5,300						
	LOW	0.64	62,187			23.63	677	0.20	98,800						
	AVG	1.12	161,323			23.63	677	0.54	333,548						
TOTAL	AVG	1.33	276,715			5.58	23,601	0.79	1,496,259	0.47	146,449	9.98	6,692	2.00	31

Figure B.1.c. Recent Cataloging Costs (FY2009)

Appendix C: Cataloging Guidelines

	<u>Page</u>
A. Overview	C:1
What types of guidelines are in this appendix?	C:1
Can I use the information in this appendix with all types of collections?	C:1
B. Component Parts, Pairs, and Sets	C:1
What are component parts?	C:1
How do I catalog objects with component parts?	C:2
How do I catalog pairs?	C:2
What are sets?	C:2
How do I catalog sets?	C:2
Can I give the pieces of a set separate catalog numbers?	C:2
C. Methods of Describing Objects	C:3
What's the best way to describe an object?	C:3
Are there common ways of looking at objects?	C:3
D. Terms for Describing Object Condition	C:4
Are there standard terms for describing an object's condition?	C:4
Why is it important to be precise when describing condition?	C:4
What are some standard terms for describing condition?	C:4
E. Measuring Objects	C:8
Why should I measure objects?	C:8
What tools do I use when measuring objects?	C:9
Should I use metric or English measurements?	C:9
Should I convert English measurements to metric?	C:9
May I abbreviate units of measure?	C:10
What types of objects should I measure?	C:10
How many measurements should I take?	C:10
F. Recording Dimensions and Weight	C:11
What degree of accuracy do I need?	C:11
What are some common dimensions and their abbreviations?	C:11
Must I enter dimensions in a consistent order?	C:11
How do I measure irregular objects?	C:12
How do I record more than one measurement for an object?	C:12
How do I measure objects with parts?	C:12
How do I measure incomplete objects?	C:12
When should I weigh material?	C:12
When do I use volume as a measurement?	C:13
What other ways can I use to show dimensions?	C:13
How can I learn the measuring standards for the types of material in my collection?	C:13

APPENDIX C: CATALOGING GUIDELINES

A. Overview

1. *What types of guidelines are in this appendix?*

This appendix has recommended guidelines and terms to help you with cataloging your museum collections. It includes information on:

- cataloging component parts, pairs, and sets
- methods of describing objects
- uniform terms to use when describing condition
- measuring and recording dimensions and weight
- cataloging nitrate negatives

2. *Can I use the information in this appendix with all types of collections?*

In general, the guidelines in this appendix apply to cultural resources collections. The guidelines for measuring (Sections E-F) also apply to natural history collections.

The lists and terms in this appendix are by necessity incomplete. Add your own lists and references for descriptions and terms specific to the material in your park's collection.

Refer to Appendix L: Bibliography, in this handbook for references on specific types of objects.

B. Component Parts, Pairs, and Sets

1. *What are component parts?*

Many objects have removable parts. The most common example is a teapot and its lid. Objects with component parts usually meet the following conditions:

- the parts can be physically separated or detached from the object
- the object is more or less incomplete without all of its parts
- the object and its parts were manufactured or made together
- the object name includes its separate parts

A vacuum cleaner with attachments is a good example of an object with component parts. You can separate the attachments from the vacuum cleaner. The vacuum cleaner isn't complete without its attachments. The vacuum cleaner and its attachments were manufactured together. The term "vacuum cleaner" is broad enough to cover the vacuum and its attachments.

2. *How do I catalog objects with component parts?*

Give an object with component parts a single catalog number, and count it as one item. Assign a lowercase letter designator to each removable part. Use the Component Parts field that appears after the Catalog Number field in ANCS+. The component part designators appear after the catalog number. For example, PARK 345 a-f shows that the object 345 has six component parts. You should mark the catalog number and appropriate designator on each part.

The ANCS+ Component Parts supplemental record allows you to list the names of the component parts. Refer to Section III of Chapter 3 in the *ANCS+ User Manual* for information on using this supplemental record.

Don't assign individual catalog numbers to the component parts of an object.

3. *How do I catalog pairs?*

Catalog a matched pair, such as a pair of shoes or matching andirons, with a single catalog number. Give each item a suffix of a or b. Use the Component Parts field that appears after the Catalog Number field in ANCS+. Count the pair as one item. Note in the Description field that the object is a pair. You should mark the catalog number and appropriate designator on each part.

Don't catalog pairs on separate catalog records.

4. *What are sets?*

Sets or kits are groups of objects intended to be used together. The word "set" or "kit" should be part of the object name. A set or kit usually includes different types of items, such as a surgical kit or a manicure set. If objects are the same, such as a set of identical bowls, use lot cataloging. Refer to Appendix I in this handbook for information on lot cataloging.

Note: For history objects, check the ANCS+ controlled table of history terms. This table includes a list of the approved terms that use "set" or "kit" as part of the object name.

5. *How do I catalog sets?*

Give the set or kit one catalog number. Give each removable piece of the set or kit a lowercase letter designator. Use the Component Parts field that appears after the Catalog Number field in ANCS+. You should mark the catalog number and appropriate designator on each part. Count the set or kit as one item.

The ANCS+ Component Parts supplemental record allows you to list the names of the pieces in the set or kit. Refer to Section III of Chapter 3 in the *ANCS+ User Manual* for information on using this supplemental record.

6. *Can I give the pieces of a set separate catalog numbers?*

Yes. You should individually catalog items in a set or kit that are of high value or susceptible to theft. For example, you might assign individual catalog numbers to the items in a Civil War surgeon's kit that is on exhibit.

If you individually catalog the items in a set or kit, be sure to cross-reference between the catalog numbers.

C. Methods of Describing Objects

1. *What's the best way to describe an object?*

There isn't one best way to describe objects. Descriptions depend on the type of material and the subject discipline. For example, archeologists use terms and standard descriptions that are different from descriptions of fine arts material.

The best way to describe the objects in your collection is to be consistent in the terms and methods you use. Set up templates for how to describe the specific materials in your park's collection. Consistency is especially important if you have many different catalogers. It gives you and others better access to data about your collection.

Note: If you are unfamiliar with cataloging, look at the ANCS+ fields and the on-line field help for the discipline you are cataloging. Specialists chose the discipline-specific fields for each discipline. These fields will give you a good idea of the types of information you need to record.

2. *Are there common ways of looking at objects?*

Yes. There are some common methods for looking at objects. Record the distinguishing and significant features. You can learn a lot of information about an object by looking at it. Other types of information, such as the date when an object was made, will require research.

Use the list below as a guide to get you started recording observable data.

Overall Shape/Style	Round, square, rectangular.../ Chippendale, Queen Anne...
Details of Shape	Work from the base to the top or describe it as it's normally described in the discipline.
Manufacturing Techniques	Fired, tanned, coiled ...
Materials	Mention materials if not sufficiently covered in the Medium/Materials field.
Texture	Corrugated, cord-marked...
Color	Reference to the Munsell color chart.
Design Details	Rosette, scroll, cross-hatching...
Condition Features	Point out features that make the object unique, such as "paint peeling" or "foxing".
Marks	Proofmarks, hallmarks, serial numbers, signatures, watermarks in paper, inscriptions.
Labels	Copy any original labels that are attached to the object or labels made with or for the object.

Note: ANCS+ has separate fields for many descriptive elements, such as marks, color, style, and manufacturing technique.

D. Terms for Describing Object Condition

1. *Are there standard terms for describing an object's condition?* Yes. There are standard terms for describing the condition of an object on an object condition report or on the catalog record. Using these terms helps you precisely describe condition and helps other people understand your description.

Note: Conservators may use different terms for describing condition.

2. *Why is it important to be precise when describing condition?* Precise vocabulary allows you to detect changes in the condition of an object from one inspection to the next. For example, condition descriptions, such as “corrosion on tip of blade” or “flaking paint,” may call attention to the need for conservation work.

3. *What are some standard terms for describing condition?* The following list includes terms that will help you with condition descriptions.

Abrasion A surface loss apparently caused by friction. The loss may be to the substance of the object or to paint or other decoration on it. Often superficial. Related terms: Scrape, Rub.

Accretion A relatively widespread accumulation of extraneous material adhering to the surface of an object that alters the original texture and usually the color, either generally or locally. Usually tenacious. Often seen on objects that were buried. Related terms: Incrustation, Stain, Spot.

Adhesive Residue Usually a sticky residue from glue, paste, or tape.

Bleaching Lightening of color through exposure to light and/or chemical agents.

Bleeding The suffusion of a color into adjacent materials, usually other colors or a ground. Often caused by water or other solvents. Also refers to the penetration of ink through paper.

Blister An inflated pocket in a film or layer. A separation between layers that appears as an enclosed, bubbled area. Generally used when describing painted surfaces. A broken blister may result in a rupture.

Bloom The bluish-white cloudiness often seen on varnished surfaces, especially paintings and wood furniture. Sometimes called efflorescence.

Break An abrupt, significant change or interruption in a continuous surface. Disruption or total separation of parts, as distinguished from a fracture.

Brittle Loss of flexibility causing the material, usually thin, to break or disintegrate when bent.

Bronze Disease Appearance of powdery, light green spots, resulting from exposure to moisture. Attacks copper, bronze, and brass.

Buckling	A distortion of a plane surface caused by shrinkage or compression. A distortion of the flat plane of a painting or other picture often accompanied by a rupture in a paint or ground layer.
Check	A rupture in wood along the grain and less than the length of the piece, usually caused by the drying of wood at an exposed end grain. Checks may appear anywhere along the grain due to surface shrinkage. An incomplete split.
Chip	A small cavity in the surface of an object caused by material that has been broken away. See also: Dent, Dig, Gouge.
Cleavage:	Separation between or in any of the layers in a stratified composition or construction. This term is used primarily when describing oil paintings and refers to separation between paint layers caused by the contraction of the support.
Corrosion	The chemical alteration of metals caused by agents in the environment or by reagents applied purposely. Hard nodules or crusts are formed on metal surfaces. The color and texture of a metal surface may be changed without alteration of the form if there is no increase in the volume of the corrosion products. Rust is the corrosion product of ferrous metals. Tarnish is a corrosion product of silver. Use the general term "corrosion" for all other metals. See also: Incrustation, Efflorescence, Patina.
Crack	A surface fracture or fissure across or through a material. It can be in a straight line or branch. There is no loss to the object. A blind crack stops part way. A hairline crack is a tiny fissure. An open crack is a large fissure.
Crackle	A system or pattern of fracture lines in a painted or varnished surface. Also a system or pattern of fissures, sometimes purposeful, in the glaze of ceramic ware.
Crazing	A very fine system of crackle or cracking in a varnish, paint film, and glass that appears slightly opaque to the eye. It may be found in aged painting films that are very dry and are approaching their final stages of embrittlement. It can powder off. This term also applies to surfaces of old varnished furniture.
Crease	A tightly pressed fold, causing fibers of cloth, paper, or leather to weaken and break.
Cupping	Varnish, paint, or ground that stand as islands with edges lifted and raised away from each other or from lower layers. Strong cupping can distort the support of an oil painting. Related term: Curling.
Delamination	A separation of layers. A type of splitting.
Dent	A surface defect caused by a blow. A simple concavity from which no material is missing. See also: Chip, Dig, Gouge.

Dig	A surface defect caused by a blow. A dig implies that some surface material has been displaced, usually laterally, but that little or no material has been completely removed. See also: Chip, Dent, Gouge.
Discoloration	A partial or overall change in color caused by aging, light, and/or chemical agents. Includes yellowing and darkening; bleaching, the lightening of color; and fading, a loss of color and/or change in hue.
Disjoin	The partial or complete separation of a join between two members or elements of an object, as distinguished from separation at some point other than a join, such as a fracture, tear, check, or split.
Dry Rot	Decay of seasoned wood that is caused by fungi that consume the cellulose of wood, leaving a soft skeleton that is readily reduced to powder.
Efflorescence	Change from a crystalline salt to a powdery mass with loss of water. The term is used more broadly for museum objects to describe powdery or crystalline crusts on the surface of stone, ceramics, or metals, resulting from other interactions. Not to be confused with corrosion, which is a surface oxidation or other chemical reaction between surface molecules and the environment. Efflorescence results from molecules surfacing from the interior of the object because of chemical changes or hydrostatic pressures within. See also: Corrosion, Incrustation.
Embrittlement	A loss of flexibility that causes material such as paper and leather to break or disintegrate when bent or curled.
Ferrotyping	Glossy patches found on the surface of photographs that have had lengthy contact with a smooth-surface enclosure, such as polyester or glass.
Flaking	A loss of material, usually from the surface, resulting from cleavages or crackles in the surface layers. Also a method of manufacture for stone tools.
Fracture	Refers to the cracking of hard substances, such as bone, and implies an incomplete break in which there is no significant separation of material. A break can later occur along a fracture line. See also: Rupture.
Fragment	A part broken off or detached, or an object that is incomplete. Use of the term usually implies a small percentage of the whole.
Fraying	Raveled or worn spot indicated by the separation of fibers, especially on the edge of fabric or paper.
Gouge	A surface defect caused by a blow. A gouge implies that some material has been scooped away. See also: Chip, Dent, Dig.
Grime	Soil tenaciously held on the surface of an object.
Hole	An opening through a substance. Usually implies that some of the substance is missing and not simply pushed aside as in a tear or dig. Also implied is that the hole is a defect, although it could be a later intentional modification. See also: Gouge.

Incrustation	A crust or hard coating of some foreign material or product on the surface of an object. Use the more specific terms corrosion and efflorescence, if the nature of the incrustation is known.
Iridescence	Color effect in glass due to the partial decomposition of the surface and the formation of innumerable thin scales, resulting in an uneven, flaky surface.
Loss	A general term applying to a missing area or hole. Note the extent of the loss.
Missing element	Loss of an integral component of the object.
Oxidation	Surface “crust” or tarnish on metal resulting from a chemical reaction with oxygen in the presence of moisture. It can be a dull, reddish-brown or black film, depending on the metal type.
Patina	A surface oxidation, corrosion, or decomposition, usually on glass, lead, pewter, or copper or one of its alloys, which is homogeneous, usually hard, and often attractive. A patina or lack of it is no guarantee of age. The patina often provides a protective barrier against further corrosion, and, consequently, may be desirable to retain. See also: Corrosion, Incrustation. The term may be used to describe the polished glow acquired by wood that has been frequently handled.
Pitting	Series of small, irregular, shallow pinhole-size surface depressions due to the introduction or spattering of some eroding or corrosive agent.
Red rot	Powdery red substance found on vegetable-tanned objects that is the result of a chemical reaction with pollutants in the air.
Rip	A hole or flaw caused by a pulling in one rapid uninterrupted motion, especially along a seam or by a joint, or along the straight-line of a fabric. A rip has relatively even or straight sides.
Rub	A mar on the surface of an object caused by contact with another body under pressure and friction. Distinct from abrasion or scrape in that no surface material appears to have been removed, although surface texture, sheen, or reflectance may have been altered.
Rupture	Refers to the tearing or breaking of soft substances, such as layers of an oil painting. It implies that surface material is forced outward, though not necessarily lost. See also: Fracture.
Scrape	Surface damage or injury caused by one or more strokes by an edged instrument or an abrasive resulting in shallow loss of surface material over a relatively wide area. Shallow gouges may occur simultaneously. See also Abrasion.
Scratch	A linear surface loss due to abrasion with a sharp point.
Silvering	Shiny or mirror-like discoloration in the shadow areas of a photographic image caused by the aging of excessive residual silver compounds. Also known as bronzing or mirroring.

Spalling	Shallow losses or flaking from the surface of stone or ceramic.
Split	A rupture running along the grain of a piece of wood, bone, or ivory. It's usually caused by external mechanical means or too rapid drying. A split could develop into a break.
Soil	<p>A general term referring to any material or substance that dirties the surface of an object. Use more specialized terms whenever possible.</p> <p>Dust refers to loose soil generally distributed on the surface.</p> <p>Grime refers to soil tenaciously held on the surface.</p> <p>Smear and Fingermark refer to localized forms of grime, usually caused by human action.</p> <p>Spatter, Run, and Stream refer to dried droplets or splashes of liquid foreign material.</p> <p>Spot refers to a small area visibly different (in color, finish, or material) from the surrounding area. It is a mark made by foreign matter, such as mud, blood, paint, or ink. The implication is that the foreign matter hasn't penetrated the surface.</p> <p>Stain is similar to a spot, but the term implies discoloration of the surface by penetration of the foreign matter. Spots can stain if the surface is porous or absorbent.</p>
Stiffness	Loss of flexibility and suppleness of fibers, offering resistance to bending.
Tarnish	A dullness or blackening of a bright metal surface.
Tear	A hole or flaw caused by a forceful pulling apart of a material leaving ragged or irregular edges. If the material is organic in composition, such as paper, cloth, or basketry, individual fibers often will be split. See also: Disjoin, Rip, Split.
Wear (Worn)	Impaired, deteriorated, or consumed gradually by use or by any continued process, especially by rubbing, scraping, or washing. The term can apply to all parts of an object, not just to its surface. It can describe a defect in an object's function as well as its appearance.
Weeping	A reaction on glass between water and formic acid.

E. Measuring Objects

1. *Why should I measure objects?*

Measurements can give you important information about an object. They help you:

 - identify and describe an object
 - calculate storage and exhibit space requirements

Note: Researchers may use measurements of archeological materials and natural history specimens for comparative purposes.

When you measure objects, be sure to follow the rules for handling museum objects. Refer to the Museum Handbook , Part I, Chapter 6: Handling, Packing and Shipping.

2. *What tools do I use when measuring objects?*

Measurements should be consistent and accurate. Accuracy increases when you use the most appropriate tools for the material. Keep the equipment clean, calibrated, and in good working condition. The equipment you'll need to measure and weigh objects includes:

- folding rule
- steel tape
- cloth tape
- steel or aluminum meter rule (or smaller)
- measuring stand (upright measuring rod and a movable arm at right angles to it, for measuring height of irregular objects)
- measuring frame (grid lines marked or inscribed on a board with a raised frame along two adjacent edges for measuring length and width of irregularly shaped objects)
- calipers
- balance

Note: You can get many of these materials through the Federal Supply Service, General Services Administration (GSA).

3. *Should I use metric or English measurements?*

In most cases, use metric measurements. Use English measurements only when they are the standard measuring convention for an object. For example, the bore diameter for a Rodman Cannon is measured in inches.

The Measurements field in ANCS+ has enough space to enter both metric and English measurements, if you choose to do so.

4. *Should I convert English measurements to metric?*

No. Don't convert English measurements to metric. Remeasure the object.

Don't remeasure biological specimens. Collectors take measurements from fresh specimens. The specimens may dry and shrink over time.

5. *May I abbreviate units of measure?*

Yes. The following list supplies common examples of units of measurement and abbreviations. Use all capitals or lower case for abbreviations, but be consistent in your use. Don't use periods with abbreviations.

centimeter	CM	cm
cubic centimeter	CC	cc
cubic feet	CF	cf
feet	FT	ft
gram	G	g
inches	IN	in
kilogram	KG	kg
linear feet	LF	lf
liter	L	l
meter	M	m
milligram	MG	mg
millimeter	MM	mm
milliliter	ML	ml
ounce	OZ	oz
pound	LB	lb

6. *What types of objects should I measure?*

Take measurements appropriate to the specific discipline. For example, measure archives by linear or cubic feet.

Measure or weigh all cultural objects if you catalog them individually. For lot cataloged objects (see Appendix I in this handbook), you might:

- measure all the objects, if there are only a few
- measure a representative sample from the lot
- decide not to measure the objects
- choose to weigh the objects

Measure or weigh geological and paleontological specimens, as appropriate.

Usually you'll find biological specimen measurements on the specimen label. Copy the label information exactly. There are specific conventions for measuring most specimens. For example, the measurements for mammals are total length, length of tail, length of hind foot, and height of ear in millimeters. The dimensions are followed by the weight in grams. Dashes separate the measurements.

Generally, collectors don't take measurements of plant or insect specimens. Collectors usually measure mammals, birds, and reptiles while the specimens are fresh, before preparation.

7. *How many measurements should I take?*

Take a minimum of two dimensions or measure by volume or weight. In general, use height (or length) and width for two-dimensional objects. Use height, length or width, and depth or thickness for three-dimensional objects. You may need additional measurements for specific types of objects.

F. Recording Dimensions and Weight

1. *What degree of accuracy do I need?*

You want to be as accurate as possible. Use the following guidelines when taking measurements:

- Don't measure beyond the level you can accurately judge.
- Make all measurements for a single object in the same unit of measure to the same degree of accuracy.
- Measure the point of greatest dimension, such as the widest part of the object.

<i>If an object...</i>	<i>Then...</i>
measures less than one meter,	measure it in centimeters to the nearest tenth (0.1) of a centimeter.
measures more than one meter,	measure it in meters to the nearest centimeter.

2. *What are some common dimensions and their abbreviations?*

Complete measurements include the unit of measure and the type of dimension. The most common types of dimensions and abbreviations appear below. Use all capitals or lower case for abbreviations, but be consistent in your use. Don't use periods with abbreviations.

Circumference	CIR	cir
Depth	D	d
Diameter	DIA	dia
Height	H	h
Length	L	l
Radius	R	r
Thickness	T	t
Volume	V	v
Width	W	w

Note: Use depth for measuring an item from an outer surface to some interior space, such as the depth of a chair. Use thickness to measure the distance between outermost edge to outermost edge, such as the thickness of a book.

3. *Must I enter dimensions in a consistent order?*

Yes. Use the same order when recording dimensions, and use the same format consistently for each type of object. For example, enter the height, width, and depth of chairs. Height usually goes before width. Consistent order and format make it easier to compare objects.

Separate dimensions by a comma and a space, unless there is a standard convention for the discipline. For example, dashes are always used between mammal measurements.

Place the abbreviation of the type of dimension before the number. Place the

unit of measurement at the end. If the value is less than one, use a zero before the decimal point.

Example: H 15.0, W 8.9, L 5.6 cm
H 10.3, W 6.8, D 4.5 cm
L 20.3, W 15.6, T 0.5 cm
H 15.5, DIA 8.4 cm

4. *How do I measure irregular objects?*

Always give maximum measurements unless otherwise noted. If necessary, use the abbreviation “irreg” in parentheses. Use height or length for the greatest dimension, unless you know the orientation of the object is different.

Example: H 4.9, W 3.7, T 1.3 cm (irreg.)

5. *How do I record more than one measurement for an object?*

Use qualifiers for more than one measurement or maximum and minimum measurements. Place the qualifiers in parentheses after the dimension type.

Example: H (max) 20.3, H (min) 10.5, W 5.0, T 1.2 cm
H 40.0, W (Top) 32.0, W (Btm) 36.5, T 12.1 cm

6. *How do I measure objects with parts?*

Record the overall measurements for the entire object. Normally, overall dimensions include separable parts like a vessel and its lid or a pipe and its stem. You can use notes to show whether the measurement includes parts such as a handle or base.

Example: L 5.3, Dia 6.9 cm, w/handle

If you want to separately measure the parts, record these measurements after the overall measurements. Note which part you are measuring.

Example: Pipe: H 3.8, L 17.5, DIA (bowl) 2.5 cm
Handle: L 12.5, W 1.0 cm
Bowl: H 3.8, L 5.0, DIA 2.5 cm

7. *How do I measure incomplete objects?*

Record the overall measurements of the object. If the object is incomplete, note this in the Condition field of the catalog record. You may want to note which parts are missing in the Description field of the catalog record.

To show that a certain dimension is incomplete for the object type, use “inc” in parentheses after the measurement.

Example: L 5.9 (inc), W 3.2, T 0.8 cm

8. *When should I weigh material?*

You can measure some objects better by weighing them. Use this method for items like pollen and lot cataloged items. Weigh to the nearest 0.1 gram or kilogram.

Example: 0.05 g

Note: You don’t need to use an abbreviation, such as WT, to show that you are recording weight.

9. *When do I use volume as a measurement?*

Volume is the most accurate measurement for objects in liquid form. It's possible to use volume either by itself or in conjunction with other measurements. The volume of certain scientific or kitchen equipment, like a 150-milliliter beaker and a liquid measuring cup, can aid in identification.

Example: V 150 ml
V 8 oz

10. *What other ways can I use to show dimensions?*

Images are a useful supplement to dimensions, particularly for irregular objects. Use a sketch, trace, or photograph to further identify the measurements of an object. You can trace small objects, if tracing won't damage the object. Note that the drawing is a trace.

Mark the image to show where you measured the object. With a sketch or trace, you can place the measurements directly on the drawing. When possible, make the sketch to scale.

With a scanner, you can digitize a sketch or trace and attach the image to your ANCS+ catalog record. If you don't attach the image to your catalog record, note on the catalog record that the drawing exists. Store the image in the catalog or accession folder.

You could also show dimensions on a digitized photograph by using photo editing software. You can attach these images to your ANCS+ catalog record.

11. *How can I learn the measuring standards for the types of material in my collection?*

There are standard methods of measuring most types of material. Consult curators with similar collections, or refer to discipline-specific texts. *The New Museum Registration Methods* has a section on measuring specific types of material. See Appendix L of this handbook for a publication citation.

Appendix D: Museum Archives and Manuscript Collections

Page

A. Overview	D:1
What information will I find in this appendix?	D:1
What categories of archival materials are covered in this appendix?	D:1
Where can I find further guidance in NPS archival materials?.....	D:1
B. General Information on Archives	D:1
What types of materials are considered archives and manuscripts.....	D:1
Are rare books or periodicals generally considered archival/manuscript materials?	D:2
Is there a difference between “archival collections” and “manuscript collections”?	D:3
What’s an archival collection?	D:3
What’s a manuscript collection?.....	D:4
What’s an “assembled” collection?	D:4
What are “park records”?	D:4
Are personal papers or organization archives acquired through donation or purchase considered park records?.....	D:5
Are there legal factors that make park records different from personal papers or the archives of non-NPS organizations?.....	D:5
C. Archival and Manuscript Collections Owned by NPS Museum Program	D:5
Is the NPS required to keep archival and manuscript collections?	D:5
Can a park acquire archival and manuscript collections for the museum collection?.....	D:5
What purposes can archival collections serve?	D:6
Should I manage archival/manuscript materials in the same way that I manage museum objects?	D:6
What are the principal differences between archival work and curatorial work?	D:6
Why are archives managed on a collection-by-collection basis rather than a document-by-document basis?.....	D:7
What kinds of archival and manuscript collections are likely to be accessioned into NPS museum collections?	D:8
D. Fundamental Principles of Archival Work	D:9
What’s “provenance”?	D:9
What’s “original order”?	D:10
What’s an archival “hierarchy”?	D:10
What are the standard levels of an archival hierarchy?	D:11
Must each collection follow a standard hierarchy?.....	D:11
What’s an easy way to remember archival concepts?	D:12
Why is it important to maintain a collection’s provenance and to arrange it according to its original order?.....	D:12
Why is it important to arrange a collection in hierarchical order?	D:13
Am I prohibited from describing archival collections at the file unit or item level?	D:13
What are the principle functions associated with archival work?	D:14
Why is it necessary to carry out these archival functions in the correct sequence?	D:14
Why is it necessary to arrange a collection before cataloging it?	D:15
How is cataloging an archival collection different from cataloging museum objects?	D:15

E. Appraisal	D:16
Why is it necessary to appraise archival and manuscript materials before accessioning them?	D:17
What are the two methods for determining whether a given collection of archival or manuscript materials should be accessioned?.....	D:17
How do I appraise donated materials?.....	D:18
What are the guidelines for appraising archival and manuscript materials?.....	D:18
What's "evidential value"?	D:18
What's "informational value"?.....	D:18
How do I evaluate a collection's informational value?	D:19
What's "legal value"?.....	D:19
What's "intrinsic value"?	D:20
What's "associational value"?.....	D:20
Are there other types of archival "values"?	D:20
How should a records appraisal be conducted and documented?	D:21
What is the collections advisory committee, and what role does it play in appraisal?.....	D:22
What kind of information do I need to gather about any records I find during a survey?	D:22
Should I prepare folder title lists, full Collection Level descriptions, full Series Level descriptions, or catalog records as part of a survey?.....	D:22
If I identify records in my survey that fall under an NPS-19 file code,how should I handle them?.....	D:22
What if I find NPS records that are not covered by a file code under NPS-19?	D:23
What if I locate non-NPS archival materials during my survey?	D:23
F. Records Schedules	D:23
What's a records schedule?	D:23
What records schedules are available for use by NPS staff?	D:24
What's NPS-19 (Appendix B)?.....	D:24
How should I apply NPS-19 (Appendix B) to park records?	D:25
What's the General Records Schedule?	D:26
What are "specific" records schedules?	D:26
How can my park get a specific records schedule?	D:26
Should NPS-19 (Appendix B), the General Records Schedule, or specific records schedules be applied to any kind of archival or manuscript materials?.....	D:26
Should NPS-19 (Appendix B), the General Records Schedules, or specific records schedules be applied to donated or purchased materials?.....	D:27
G. Accessioning Archival Material	D:27
When should I accession a collection of archival or manuscript materials?	D:27
What steps should I take to accession an archival collection?	D:27
Does each document need to have an accession number?	D:28
Does each collection have to have a single and unique accession number?.....	D:28
Can accessions be divided?.....	D:29
Can multiple accessions form a single archival collection?	D:29
What's an "accretion"?	D:29
How should I handle accretions to a collection?	D:30
H. Arrangement	D:30
What's arrangement?	D:30
Why is it necessary to arrange a collection before cataloging or using it?	D:30
What are the two key steps that I have to take in order to arrange a collection?	D:31

How do I handle items that pertain to more than one collection?	D:31
May I combine similar or related collections?	D:32
May I break collections up into multiple collections if they are very large or cover different topics?	D:32
Should I combine archival materials created by an individual while he or she was working for an organization into a collection with materials created by that same individual in his or her spare time?	D:32
Should each accession be regarded as a collection?	D:32
What's meant by "archival arrangement"?	D:32
Should all archival or manuscript collections follow the same arrangement patterns?.....	D:33
How can I determine original order if the collection has gotten out of order over the years?	D:34
Is it okay to alter original order to suit current needs?	D:35
Is it possible to arrange a collection that's no longer in its original order?.....	D:35
What if the original order is hopelessly lost, and there is no way of reestablishing it?	D:36
I. Hierarchical Structure	D:37
What's a hierarchy?.....	D:37
Why is hierarchical structure the key to arranging a collection?	D:37
What should a hierarchy look like?	D:38
How should the various elements in the hierarchy (such as series, subseries, file units) be titled?	D:38
How should a hierarchy be used?	D:40
J. Organization—Series and Subseries	D:40
What's a series?.....	D:40
How are series grouped?	D:40
What's a subseries?	D:41
When is it appropriate to have a subseries?	D:41
What's a sub-subseries?	D:42
Why is it necessary to keep dividing and subdividing archival collections?.....	D:43
When should I stop subdividing?	D:43
Should all items in a particular physical format be consolidated into a single series or subseries?.....	D:43
What's the difference between a "closed" series or collection and an "open" or "recurring" series or collection?	D:44
How should I arrange an open or recurring series or collection?.....	D:45
K. Organization—File Units and Items	D:45
What's a file unit?	D:45
Is a file unit the same thing as a file folder?	D:45
How are file units arranged?	D:46
Should I subdivide file units?.....	D:46
What are some types of file units that are not contained in folders?	D:46
What's an item?.....	D:47
L. Step-By-Step Arrangement	D:48
What's the first step in arranging a collection?.....	D:48
What sorts of things should I look for in a review?.....	D:48
What's the second step in arranging a collection?.....	D:49
What's the third step in arranging a collection?	D:49
What's the fourth step in arranging a collection?	D:49

What's the fifth step in arranging a collection?.....	D:49
When do I stop subdividing a collection?	D:49
What's the sixth step in arranging a collection?.....	D:50
What's the seventh step in arranging a collection?.....	D:50
How should I arrange an assembled collection?.....	D:50
M. Handling Resource Management Records.....	D:51
What are resource management records?.....	D:51
What are the two acceptable methods for handling resource management records?.....	D:51
What commonly used method of handling resource management records should I avoid?	D:51
How is it possible to find individual files if all resource management records or all records associated with the projects in a specific discipline are covered in only one catalog record?	D:52
How should I arrange a collection containing all of a park's resource management records, including the associated records?.....	D:53
How should I arrange associated records that are handled as separate collections?.....	D:53
If all project files for a discipline are brought together into a single collection, isn't that like mixing collections or creating an artificial collection?.....	D:55
How should I catalog a collection of associated records?	D:56
What if project files are held at different locations – with some at the park, some at a regional archeological center, and some at a partner repository?.....	D:56
How should I arrange and catalog new project files that are accessioned after I have finished cataloging a collection of associated records?.....	D:57
Do these methods for arranging records satisfy the Code of Federal Regulations requirement for keeping archeological objects together with their associated records?	D:57
Without a unique catalog number, how can associated records be cross-referenced to the objects?.....	D:57
How can I loan individual documents or files if they don't have unique collection numbers?	D:57
N. Processing and Preservation.....	D:58
When should I process an archival or manuscript collection?	D:58
What supplies and equipment will I need to process an archival or manuscript collection?	D:58
What are textual and non-textual materials?.....	D:59
Should I process textual and non-textual materials differently?.....	D:60
What should be done if a collection contains documents that are folded?	D:60
How should I handle paper records that are acidic?	D:60
How should I handle paper records that are fragile?	D:60
How should I handle paper records that are damaged?	D:61
When should I make "preservation copies"?.....	D:61
May I cull material during processing?.....	D:61
What are some examples of materials that can be culled?	D:62
O. Processing and Preservation—Paper-Based Documents.....	D:62
How should I refolder and rebox paper-based documents?	D:62
What size folders or boxes should I use?	D:63
Should I remove paper clips, staples, and other fasteners?	D:63
Should I remove documents from binders?	D:63
How should I handle multi-page documents?	D:63

Can I break materials into multiple folders if the original file folder is too full?	D:63
How should I label the folders?	D:64
Should I copy everything written on the original folder?	D:64
How many file folders should I place in a box?	D:65
May I mix files from different collections in the same archives box?	D:65
How should I label the boxes?	D:65
Should I keep the original folders, binders, and boxes?	D:66
P. Processing And Preservation—Oversized Materials	D:66
How should I handle oversized materials?	D:66
How do I show the removal of oversized materials?	D:67
Why do oversized documents have to be removed?	D:67
How should I file oversized items after they're removed from their original locations?	D:67
Should I handle a group of oversized materials at the end of a collection as a series (or subseries)?	D:68
Q. Processing And Preservation—Photographs	D:68
How should I handle photographs that are part of standard textual files?	D:68
What if photographs are attached to pages in a textual document?	D:68
Should I add photographs that were separated from textual records to a series consisting exclusively of photographs?	D:69
How should I house photographs?	D:69
Should I place loose photographs in albums?	D:69
How should I process photograph albums?	D:70
R. Cataloging	D:70
What's "cataloging"?	D:70
Should there be a catalog record for each document in a collection?	D:70
What if a document is pulled from a collection to go on loan?	D:70
Should there be a catalog record for each file unit in a collection?	D:71
Should there be a catalog record for each series or subseries in a collection?	D:71
What's the connection between archival hierarchies and archival cataloging/description?	D:71
What's the process for cataloging an archival collection?	D:71
Do I have to enter information from the top down?	D:72
Why must I enter information from the top down?	D:72
S. Description	D:72
What's description?	D:72
How do I write a Collection Level description?	D:72
How do I write a Series Level description?	D:73
Should I enter descriptions in the Archives Module for all series, subseries, sub-subseries, and sub-sub-subseries in a particular collection's hierarchy?	D:74
How do I write a File Unit Level description?	D:74
Are File Unit Level descriptions required?	D:74
Are there situations where file unit description is recommended?	D:75
How do I write an Item Level description?	D:75
Is Item Level description required?	D:75
Is it more appropriate to do Item Level description of certain types of documents than others?	D:75
Can Item Level description help preserve collections by reducing the need to search through the documents?	D:76

Should I make Item Level entries in the ANCS+ Item Level-Only directory?.....	D:76
Why is it so important to enter Item Level descriptions in the hierarchically organized Archives directory and not the Item Level-only directory?	D:77
T. Folder Title Lists and Finding Aids	D:77
What's a folder title list?	D:77
What are the two methods for preparing folder title lists?.....	D:77
Are folder title lists mandatory?	D:78
When is it appropriate to do a folder title list?	D:78
When is it unnecessary to do a folder title list?	D:78
What's a finding aid?	D:78
Does NPS have a template for producing finding aids?	D:78
What are EAD and MARC-AMC?	D:79
Is it mandatory to use EAD or MARC-AMC?	D:79
U. Access	D:79
Are staff members at any park permitted access to park archival and manuscript collections?.....	D:79
Are non-NPS staff members permitted access to park archival and ...manuscript collections?	D:80
Is there one set of rules to follow when deciding whether members of the public are allowed to see certain documents?	D:80
What are the rules for determining public access to a collection of personal papers, private sector corporate archives, or other non-NPS documents?	D:80
What kinds of "personal privacy" information may I withhold from researchers?	D:80
Can these types of personal privacy restrictions be placed on non-Federal records as well as Federal records?	D:81
What types of restrictions may I place on "culturally sensitive" archival materials?	D:81
How should sensitive information in personal papers or private sector records be withheld from researchers?.....	D:81
Should I withhold copyrighted materials from researchers?	D:81
Is it permissible to restrict or withhold Federal records that have previously been released?.....	D:81
What's the principle of "Equality of Access"?	D:81
Can I restrict access to archival or manuscript materials if the purposes or methods of a person's research are questionable?.....	D:82
V. Freedom of Information Act (FOIA)	D:82
What are the rules for determining public access to NPS or other Federal records that are part of the museum collection?.....	D:82
What are some FOIA exemptions?	D:82
What are the procedures for responding to a FOIA request?	D:83
How can FOIA-exempt information be removed from files or withheld from researchers?	D:84
Do I have to conduct a new FOIA review every time a member of the public asks for a particular file or document?.....	D:84
Should I handle all requests for information from archival and manuscript collections as if they were FOIA requests?.....	D:84
Should I review research proposals to determine if it's appropriate to grant access to the records?.....	D:85
Does FOIA apply to all archival and manuscript materials in NPS museum collections?	D:85

	<u>Page</u>
Are personal papers that the park receives through donation or purchase considered “records received by the Federal government,” and therefore subject to FOIA?.....	D:85
W. Use—Reference	D:86
Are researchers subject to any restrictions when using archival and manuscript collections?.....	D:86
When members of the public come to the park to conduct archival research, where should they work?.....	D:86
May researchers be permitted to “check out” files, in the manner that someone would check a book out from a library?.....	D:86
How should I configure a research room or research area?.....	D:86
What procedures should staff follow when working with on-site researchers?.....	D:87
What procedures should researchers follow when they’re in the research area?	D:88
What forms should I require researchers to complete?	D:89
Do researchers need to meet any age restrictions?	D:89
Should researchers make appointments before arriving to do archival research?	D:89
What other scheduling and logistical arrangements should parks make in order to protect archival materials and facilitate their use by outside researchers?	D:90
What arrangements should parks make to provide copies of documents to private researchers?.....	D:90
What are the procedures for responding to researchers who aren’t on site?	D:91
X. Copyright	D:93
May I give researchers copies of copyrighted materials?	D:93
Are materials in NPS-owned archival and manuscript collections copyrighted?	D:93
How will I know if a document has been copyrighted?	D:93
Who’s responsible for determining if a document has copyright protection?.....	D:94
When should parks grant “permission” to publish copyrighted materials?	D:94
What warnings or guidance should I give to researchers regarding the use of copyrighted materials?	D:94
Where may I find guidelines for determining if materials are likely to be in the public domain?	D:95
Y. Use—Publications, Exhibits, Loans	D:95
How should researchers cite NPS-owned archival materials that they have used?.....	D:95
May the park request a complimentary copy of a publication based on NPS-owned archival or manuscript collections?	D:95
Can I loan archival materials?.....	D:95
May archival materials be used in park museum exhibits and in park interpretive programs?	D:95
Z. Understanding the Language: A Glossary	D:96
AA. Identifying Further Sources of Archival Training and Guidance	D:102
BB. Readings: A Bibliography	D:103
CC. List of Figures	D:112

APPENDIX D: MUSEUM ARCHIVES AND MANUSCRIPT COLLECTIONS

A. Overview

1. *What information will I find in this appendix?*

This appendix gives guidance on how to manage archival materials that are accessioned into NPS museum collections. Archival materials advance the NPS mission of education, management, preservation, and research.
2. *What categories of archival materials are covered in this appendix?*

This appendix covers all categories of archival materials that may be accessioned into NPS museum collections, including:

 - Records created by the park (such as associated records and other resource management records)
 - Copies of records created by the park, if the park is required to transfer the originals to the National Archives
 - Personal papers acquired through donation or purchase
 - Organizational archives acquired through donation or purchase
3. *Where can I find further guidance on NPS archival materials?*

Further guidance on archival materials appears in:

 - NPS-28, *Cultural Resources Management Guideline*, Chapter 9.1
 - ANCS+ *User Manual*, Appendix F
 - DOI *Museum Property Handbook*, Vol. II
 - NPS-77, *Natural Resource Management Guidelines*
 - DO-19, *Records Management*
 - NPS-19, *Records Disposition Schedule*
 - NPS *Records Management Handbook*
 - NPS *Conserve-O-Grams*

Guidance on NPS records falls under the authority of the NPS records manager and the National Archives and Records Administration (NARA). Park records include materials such as central files, financial records, and personnel records. Guidance on these records appears in NPS-19, *Records Management*, and in the NPS *Records Management Handbook*.

B. General Information On Archives

1. *What types of materials are considered archives and manuscripts?*

Archives and manuscripts include all types of documents, regardless of format. See Table 1 for examples. Documents may be in hardcopy (paper), or in any kind of magnetic, electronic, digital, or film technology.

Individual documents may be loose, or they may be contained in file folders or in bound volumes. Carbon copies, photocopies, and other duplicates may be regarded as “original documents,” depending on specific circumstances. For example, if an individual sent a letter to someone and kept a copy of that letter in his or her own files, then that copy would still be regarded as an original document in the individual’s manuscript collection.

Examples of Archival Materials
<ul style="list-style-type: none"> • letters, reports, memorandums, minutes, notes, telegrams • newspaper clippings • maps, charts, architectural/engineering drawings • albums, ledgers, diaries • photographic prints, photographic negatives, slides • motion picture film • microfilm, microfiche • phonograph records, sound recordings on reel-to-reel or cassette tapes, digital sound recordings • video recordings on VHS, Beta, or other formats • punch cards, automated data on magnetic tape, and any type of material contained on floppy disks, compact disks, and DVDs <p>Note: Individual documents may be loose, or they may be contained in file folders or bound volumes.</p>

Table 1. Archival Materials

2. *Are rare books or periodicals generally considered archival/manuscript materials?*

No. Rare books and periodicals aren’t considered archival/manuscript materials unless they are part of a larger archival or manuscript collection.

<i>If...</i>	<i>Then...</i>
published books and periodicals are sufficiently rare to warrant accessioning into museum collections (as opposed to being managed as part of library collections),	handle them as individual museum objects, not as archival materials.

However, there are exceptions to this rule. For example:

<i>If...</i>	<i>Then...</i>
a collection includes a letter that discusses a particular book, and a copy of the book was sent as an attachment to the letter,	consider the book as part of the letter, and as such it’s archival.
an archival collection includes the research files of an individual or organization, and magazine	the magazines would be considered archival.

articles, or even entire magazines, were included as part of those files,

a person or organization actually published books, pamphlets, or other publications, and kept a record set of those publications,

the publications would be part of the archival collection.

Note: Ledgers, diaries, albums, and other bound materials that resemble published books are not actually books. These are unique records created by individuals or organizations. Handle them as archives.

3. *Is there a difference between “archival collections” and “manuscript collections”?*

Yes. “Archival collections” generally are groups of documents created by organizations, such as government agencies, corporations, and non-profit groups. (“Archives” can also mean the building or room where archival collections are housed and the organization responsible for managing archival collections).

“Manuscripts” are single documents or collections of documents created by individuals or families. These collections are sometimes called “Personal Papers.”

“Manuscripts” may also refer to groups of individual documents that were:

- created by different persons or organizations, *and*
- assembled later from multiple sources

To avoid confusion, this appendix will call such collections “Assembled Collections.”

Archival collections or manuscript collections created by a single person or organization are “organic collections,” because they grow naturally as the result of the record creator’s activities. They include the letters, reports, receipts, and other documents that a person or organization accumulates and files as they go about their business.

Manuscript collections that are assembled from multiple sources or created by different persons or organizations, however, are “artificial collections.” These collections did not accumulate naturally as a by-product of a person or organization’s activities, but were acquired and brought together artificially by a collector.

4. *What’s an archival collection?*

An archival collection is a group of documents:

- created or received by a single government agency, corporation, non-profit organization, or other body, in the course of doing business, *and*
- filed together as a unit

An archival collection should include all the historically significant documents that the organization:

- actually created, such as reports, letters, memorandums, charts, photographs, and sound recordings, *and*
- received, such as letters sent to the organization by outside individuals or organizations

An archival collection should remain intact. Don't parcel it out among multiple collections. Don't mix it with other collections.

Note: For guidance on how to determine the historical significance of a collection, see Section E, Appraisal.

5. *What's a manuscript collection?*

A manuscript collection is a group of documents:

- created or received by a single individual or family, *and*
- filed together as a unit

A manuscript collection should include all the historically significant documents that the individual or family:

- actually created, such as letters, diaries, photographs, and sound recordings *and*
- received, such as letters sent to the individual or the family by other individuals or by organizations

A manuscript collection should remain intact. Don't parcel it out among multiple collections. Don't mix it with other collections.

Manuscript collections are also called "Personal Papers."

6. *What's an "assembled" collection?*

An assembled collection is:

- a group of documents created by different individuals or organizations, *and*
- compiled later from multiple sources

An assembled collection is also called an "artificial" collection because the documents bear no organic relationship to each other. That is, they were not created by a single person or organization. They didn't accumulate naturally as a record of the activities of that organization or individual.

For example, a manuscript collector draws upon a variety of sources to assemble a group of letters from African-American soldiers during the Civil War and a group of photographs on a single site taken by different photographers. The collector then sells or donates these "assembled collections" to the park.

7. *What are "park records"?*

Park records are records created or received by park staff in the course of conducting official activities. They can include letters, reports, notes, and memorandums actually written by park staff, as well as letters or other documents that they received. NPS records should be handled in accordance

with NPS Directors Order 19 (see Section F).

Example: A park superintendent writes a letter to a contractor concerning an archeological monitoring project carried out at the park and keeps a copy of the letter in the park's files. The contractor responds by sending the superintendent a letter, which also goes into the park's files. Both the copy of the letter sent by the superintendent and the letter that the contractor sent to the superintendent are park records.

8. *Are personal papers or organizational archives acquired by the park through donation or purchase considered park records?*

No. Only documents created or received by the park in the course of official activities are park records.

Documents created or received by a private individual, family, corporation, or non-profit organization, retained as part of the files of that person, family, corporation, or non-profit organization, and later acquired by the park through donation or purchase are not park records. They are not a record of official activity but are simply museum property.

9. *Are there legal factors that make park records distinct from personal papers or the archives of non-NPS organizations?*

Yes. Park records are covered by the Federal Records Act and access to them is governed by the Freedom of Information Act. They generally cannot be copyrighted. The personal papers of individuals or families and the archives of corporations or non-profit organizations:

- are not covered by the Federal Records Act,
- are not subject to the Freedom of Information Act or other regulations governing access to Federal records, *and*
- may be protected by copyright—even if those collections are owned by the park.

C. Archival and Manuscript Collections Owned by NPS Museum Programs

1. *Is the NPS required to keep archival and manuscript collections?*

Yes. In accordance with law or NPS regulations, parks must keep certain types of archival materials created by the NPS. For example, NPS regulations require parks to maintain resource management records. Parks are required by statute to retain associated records (such as field notes and reports on projects carried out at the park in archeology, paleontology, biology, ethnology, and geology—regardless of whether they were carried out by NPS staff, contractors, or private researchers working under park-issued permits). Parks should also retain files on historic structures, cultural landscapes, and other mission-related activities.

2. *Can a park acquire archival and manuscript collections for the museum collection?*

Yes. Parks can acquire archival collections that fit their Scope of Collection Statements. Parks can acquire archival collections through donation, purchase, transfer, or exchange.

Archival and manuscript collections play the same vital role in a collection as three-dimensional museum objects. These collections can document, commemorate, and reflect the cultural, natural, and historical themes and events associated with a park. For example, the museum collection at Thomas Edison NHS includes Edison's personal papers and the records of

the Edison Company. These materials are as important a part of the collection as Edison's first phonograph and the desk where he did his work.

3. *What purposes can archival collections serve in a collection?*

Archival collections can serve a variety of purposes. They can provide:

- baseline information essential for managing cultural and natural resources
- contextual information necessary for understanding archeological, biological, and paleontological museum objects
- research materials for use by NPS staff, as well as by non-NPS historians, archeologists, and other scholars
- information for park-based educational and interpretive activities, such as exhibits, curriculum development, publications, and websites

4. *Should I manage archival/manuscript materials in the same way that I manage museum objects?*

No. Don't manage archival/manuscript materials in the same way that you manage museum objects.

Although individual documents technically are counted as objects for reporting purposes, they are fundamentally different from objects. They are part of a larger archival collection. All of the documents within a given collection are interrelated. This affects the way documents are housed, arranged, and cataloged.

5. *What are the principal differences between archival work and curatorial work?*

There are several principal differences between archival work and curatorial work.

Cataloging by collection versus cataloging by object or lot

- Archival cataloging is fundamentally different from object cataloging. Object cataloging involves creating individual catalog records for each object or for each comparatively small lot of objects. Archival cataloging, however, involves cataloging an entire collection under a single catalog record, no matter how many documents it contains. A single archival collection can contain an infinite number of documents, and the documents themselves can cover an infinite number of projects. Lot-cataloged objects, on the other hand, relate to a single project and have the same name and provenience.
- Regardless of how many documents it contains, you should regard an archival collection as a single object. Assign a single catalog number to the collection as a whole.

Object cataloging is a one-step process, involving completion of a catalog record in the Collections Management Module. Archival cataloging is a two-step process, involving completion of a catalog record for the collection as a whole, followed by Archives Module descriptions of the collection's various subordinate parts. (**Note:** Archives Module entries, in turn, can provide the basis for a full finding aid—which is a critically-important tool for using any collection. See Section S “Description” and Section T “Folder Title Lists and Finding Aids”.)

- Object cataloging usually is done on an object-by-object basis, but archival cataloging should *never* be done on a document-by-document basis—unless a document is not part of a larger archival collection. For individual documents on loan or of high monetary value, the park may complete individual catalog records in the Collection Management Module or item-level entries in the Archives Module—but it should still manage such documents as part of the larger archival collections to which they belong. Those individual catalog records for documents contained in larger collections would be done for accountability purposes only; since those documents would already be covered under the collection-level catalog record, they should not be counted a second time in the park’s Collections Management Report. When these individually cataloged documents are returned, change the status of that document’s catalog record to “Incorporated into Larger Archival Collection.”

Arrangement

- An archival collection needs to be arranged in its proper order before you attempt to catalog it. You must complete this essential preliminary work before you can create a catalog record for the collection. You can’t take a single document off the shelf and catalog it and move on to the next document. You must approach the collection as a whole and process and arrange the entire collection. Then you will understand what is in it and how the documents fit together. This is true whether the collection contains thousands of documents or only a handful of documents.

Multiple Accessions

- A single archival collection may be composed of multiple accessions, while a museum object is always associated with only one accession. For example, one archival collection may be composed of ten accessions from a single original source. Even though there are ten accessions, catalog the collection with one catalog record and one catalog number. The reverse is true in object collections, however, because an accession containing ten objects can result in ten catalog records and ten catalog numbers.

Classification versus Organization

- You don’t classify archival collections in the same way you classify museum objects. For example, you wouldn’t classify an archival collection by time period and material of manufacture or by genus and species. Instead, you analyze how each collection is organized and identify its component parts, such as series and subseries. You then base your cataloging and description on the unique internal organization of the collection.

6. *Why are archives managed on a collection-by-collection basis, rather than a document-by-document basis?*

Archives are managed on a collection-by-collection basis as opposed to a document-by-document basis for two reasons:

First, a document that is part of a collection has context and meaning in a way that an individual document cannot. A collection of documents can:

- reflect the development over time of historical themes and events
- suggest cause and effect
- show entire sequences of activities and thoughts
- help to authenticate individual documents

A single document is at best a snapshot, with little clear connection to what came before or after.

Second, as a practical matter, it's often impossible and usually unnecessary to describe each individual document in a collection. Some collections include thousands of documents. Attempting to describe each in the same detail that you would describe a three-dimensional museum object would be time-consuming and largely unnecessary. You can find individual documents more expediently in a well-organized collection than you can find individually cataloged items.

<i>If...</i>	<i>Then...</i>
it's necessary to provide detailed descriptions of individual documents within an archival finding aid,	it must be done within the context of the collection as a whole--and to do this, you should use the ANCS+ Archives Module.

7. *What kinds of archival and manuscript collections are likely to be accessioned into NPS museum collections?*

Archival and manuscript collections that may be accessioned into NPS museum collections include:

- personal papers and records of corporations or other organizations that meet a park's Scope of Collections Statement. (The park may acquire these through donation, purchase, transfer, or exchange.)
- resource management records created or received by the park for the purpose of managing park cultural or natural resources
- copies of certain NPS-created records

Note: Associated records are an example of resource management records. Associated records include field notes, site forms, reports, correspondence, maps, and drawings prepared in connection with studies or projects in such areas as archeology, ethnology, paleontology, geology, biology, etc. They are considered associated records because they are associated with objects and specimens that are accessioned into museum collections and with park sites where studies and surveys were conducted. It's necessary for the park to retain these records in order to understand and manage the objects, specimens, and sites (see Section M, "Handling Resource Management Records").

Other types of resource management records include maintenance files on historic structures, files on cultural landscapes, and land use files. These records provide baseline data and other information necessary for managing resources.

Apart from resource management records, original NPS files need to be handled in accordance with NPS-19. Even if you manage such records as a collateral duty, don't accession these records into the museum collection.

D. Fundamental Principles Of Archival Work

Archivists and curators have similar skill sets and interests. However, there are important differences between the underlying theories of archival and curatorial work. The most basic difference is that:

- archival work focuses mainly on *collections* of documents
- curatorial work focuses mainly on *individual* museum objects, or on object lots associated with *individual projects*

This section outlines some of the most important archival theories and procedures. You'll need to understand these before attempting to manage archival and manuscript materials. For further information, you may want to check the sources listed in the bibliography, or attend one or more of the archives classes offered by the National Archives and Records Administration, institutions of higher learning, and professional organizations (such as the Society of American Archivists).

1. What's "provenance"?

"Provenance" is the basis for modern archival work. It's the principle that the records of one organization or individual remain together. They must never be mixed with the records of another organization or individual.

The collection of documents that an organization accumulates in the course of doing business is a coherent whole. The collection of documents that an individual accumulates in the course of living his or her life is also a coherent whole. It's evidence of what that organization or individual did or knew. A collection shouldn't be broken up into smaller collections, and it should not be integrated with other collections. When documents from one collection are intermingled with documents from another collection, the integrity of both collections is compromised. Their research value and historical reliability are diminished. Even when collections cover the exact same subjects, themes, events, or individuals, you must maintain absolute fire walls between them.

Another meaning of "provenance" relates to the chain of custody or ownership of a collection. For example, you can trace the provenance of a park collection by starting with its current owner, the National Park Service. Then go back through any intermediate owners, to the collection's origins as the records of a particular organization or individual.

There are different options for managing associated records. Technically, you should treat associated records as series within an overall collection of the park's resource management records. Because of their special importance, it's permissible to treat all of a park's associated records for a single discipline as a stand-alone collection.

Example: All of a park's records on archeological projects may be handled as either series within the park's resource management collection or as a collection unto itself. Similarly, all of a park's records on biological projects may be handled either as a series within the park's resource management collection or as a collection unto itself (see Section M, "Handling Resource Management Records").

2. *What's "original order"?*

When organizations and individuals create records, they usually file them according to some kind of logical structure. They might keep all their correspondence together, arranged alphabetically. They might keep all their financial statements together, arranged chronologically. They might keep all their project files together, arranged according to a numerical filing code.

"Original order" refers to the way in which an organization or individual chose to maintain their records from the outset. That is, "original order" is the way in which the records were originally organized and filed.

Good archival procedure requires that a collection of records be kept in its "original order." You should avoid rearranging archival collections.

A common misconception among non-archivists is that "original order" is the order in which they found the records. This isn't necessarily true. Some collections remain in their correct, original order from the time they were created until the time they were acquired by NPS. In other cases, documents in a collection can get all mixed up before they reach NPS. When this happens, don't simply leave the collection in the order in which you found it.

When a collection has gotten out of order, you must put the collection back into its "original order." You must do this before you can proceed with further processing or cataloging. Unfortunately, there is no universal template for organizing an archival or manuscript collection. All collections are going to be unique. Section H, "Arrangement," gives tips on how to discern and re-establish the "original order" of a collection that has gotten jumbled.

There may be rare occasions when the original order of a jumbled collection is indiscernible or unusable. In such cases, an archivist may put the collection into an intelligible order. This should only be attempted if the archivist can determine that the original order cannot be re-established. For further information, see Section H, "Arrangement," Item 14.

3. *What's an archival "hierarchy"?*

The internal structure of an archival collection is called a "hierarchy." Archival collections are organized hierarchically. That is, collections are broken down into subordinate parts. These parts may in turn be broken down into subordinate parts, and so forth. You start from the top of the hierarchy with the collection as a whole. You go through the levels of the hierarchy to individual documents at the bottom of the hierarchy.

For example, suppose that a collection is composed of four parts called "series":

- Series I: Correspondence
- Series II: Financial Records

- Series III: Project Files
- Series IV: Annual Reports

Each of those series, in turn, may be subdivided into individual file units. Series III, Project Files, would be composed of individual files for each project. Each individual project file, in turn, would be composed of individual letters, memorandums, forms, or other documents.

Thus, an archival hierarchy goes from the general to the specific. Starting at the top of the hierarchy, the collection as a whole is the most general. Then the hierarchy becomes more specific as it moves down to the individual series. It then becomes even more specific as it moves down to the individual file units within those series. Finally, it reaches the most specific when it moves down to the individual documents within those file units.

Documents aren't individual museum objects or disconnected pieces of data. They're small parts of a whole. Each document will have a definite and permanent location in a larger context. Each document is related to something larger. For example, a document may be part of a file unit, which is part of a series, which is part of a full collection. This is why it's inappropriate to handle or catalog individual documents separately.

4. *What are the standard levels of an archival hierarchy?*

The standard levels of an archival hierarchy go in descending order:

- Collection Level
- Series Level (plus subseries, sub-subseries, etc., as necessary)
- File Unit Level (**Note:** A file *unit* is not the same thing as a file *folder*. A file unit is a group of documents filed together under a particular topic or title. A file folder is simply a physical device for holding those documents. It is not unusual for a single file unit to contain so many documents that it would take multiple file folders to hold all of the documents contained in that one file unit.)
- Item Level (individual documents)

5. *Must each collection follow a standard hierarchy?*

No. Each collection will have its own unique hierarchy. There's no universal template.

Some collections can have extremely simple hierarchies. A collection may be composed of a small number of individual documents that aren't organized into files or series. In that case, the hierarchy would simply involve the Collection Level and the Item Level.

At the other end of the spectrum, another collection may have an extremely complex hierarchy. It would encompass multiple series, some of which might be organized into subseries. Some of those subseries might be organized into sub-subseries. Some subseries might be made up of files that are arranged alphabetically. Some might be made up of files that are arranged chronologically. Some may be made up of bound ledgers that are arranged numerically. Some may be made up of individual documents that are not part of file folders or bound volumes.

The key is to evaluate each collection individually, by answering the questions:

- What are the collection's components (the series, subseries)?
- How are files within the various components arranged (alphabetically, chronologically, numerically)?

Remember: A hierarchy can be as simple as a single group of files arranged alphabetically, or it can be as complex as a collection that is divided into 10 or more series, all of which are divided into subseries, some of which are further divided into sub-subseries.

6. *What's an easy way to remember archival hierarchy concepts?*

Think of a collection as a multi-volume publication. Each volume would be analogous to a series. Within each volume, each chapter would be analogous to a file unit. Within each chapter, individual pages would be analogous to individual documents.

In other words, the pages of a multi-volume publication are not stand-alone objects. They follow a specific order and are arranged into chapters and volumes. Similarly, individual documents in a collection are not stand-alone objects. They follow a specific order and are arranged into file units and series.

A hierarchy is a little like an outline—you have to have two or more elements to justify going to a subordinate level. It is pointless to have an outline with just one heading (Roman Numeral I, but no Roman Numeral II), or just one subheading under a heading (Subheading II.A, but no Subheading II.B). It's the same way with archival hierarchies. You have to have at least two series to warrant organizing a collection into series. If you don't, then you just have a collection arranged into file units, with no series structure. Similarly, you should only break a series into subseries if you can identify at least two subseries.

7. *Why is it important to maintain a collection's provenance and to arrange it according to its original order?*

A collection is evidence of the knowledge, statements, and activities of the organization or individual that created the collection. If provenance and original order are protected, the collection will reflect historical development. It will show what the organization or individual knew or thought over time and document decision-making. It will also provide the context and background that are critically important to understanding the significance of each document.

For example, researchers can compare a person's diary entries with his or her outgoing letters. They can compare an organization's internal memorandums with its press releases to see if they are consistent. They can compare incoming letters with outgoing letters to determine how a person or organization responded to questions or events. They can compare documentation filed at the beginning of a project with documentation filed at the end of a project. This helps to provide a full picture of what took place.

One can evaluate the authenticity of documents more readily when they are retained in context with related documents created or received by the same

organization or individual. You compromise provenance and original order by mixing documents from one collection together with another or by rearranging collections. This makes it more difficult to:

- discern an organization's or individual's actions or responses
- recreate the context for that organization's or individual's actions or decisions
- authenticate documents

8. *Why is it important to arrange a collection in a hierarchical order?*

Hierarchical organization makes archival cataloging easier and more practical. Once you establish a collection's hierarchy, it's usually sufficient to catalog or describe only the upper levels of the hierarchy. In the vast majority of cases you don't have to catalog hundreds or thousands of individual documents or file units. It's usually only necessary to:

- complete a catalog record for the collection as a whole
- write descriptions similar to catalog records for the various series and subseries that make up the collection
- prepare a folder-title list or container list for the collection, if desired

Hierarchical organization also provides for an additional and useful method of access. Word searches and searches by accession number or catalog number are the primary methods to retrieve documents from collections that were cataloged on a document-by-document basis—but this often means that a researcher needs to have a fairly clear idea of specifically what to request. Hierarchical arrangement facilitates broader and deeper research by focusing on document types, functions, and creators. You can still do word searches and searches by accession number in a hierarchically arranged collection, but hierarchical retrieval in many cases is a more rewarding method because it does not limit researchers to documents, file units, subject terms, or accessions that they already know to request.

A properly arranged archival collection can be almost self-indexing. If a series is arranged alphabetically, you can search for specific files just as easily in the records themselves as in a finding aid—without having had to take the time to enter the titles of each file into the Archives Module. On the other hand, if you need to create finding aids with titles of each file unit, the Archives Module will make it easy to do.

9. *Am I prohibited from describing archival collections at the file unit or item level?*

No. It is always an option left to your discretion—but it should only be done when necessary. In most cases, having logically-arranged and properly-described series and subseries will be sufficient to enable researchers to zero in on the 5 or 10 file units containing the documents they need. Additional description at the file unit or item level won't add enough value to make it worth the effort—especially since container lists can provide an extremely easy alternative to full file unit descriptions. But it is always *possible* to do descriptions at lower levels of the hierarchy.

In a few instances, such as situations where you are working with associated records, full file unit descriptions may be recommended (see Section M, "Handling Resource Management Records).

One example of the sort of material where file unit description should be considered would be records relating to archeological projects. All records on a specific archeological project can be handled as a file unit within the Archives Module, and you can enter information on subjects, activities, locations, findings, investigators, and any other data concerning the project into the file unit screen—along with accession numbers linking the project with any associated objects. The files on each project will thereby retain their individual identity within the hierarchy, and will be readily identifiable within the hierarchy—but it will still be possible to do word searches and searches by accession number.

10. *What are the principal functions associated with archival work?*

The principal functions of archival work are:

- appraisal, scheduling, and accessioning (determining the long-term value of archival materials; deciding whether or not to accession them)
- arrangement (putting each collection into its hierarchical original order)
- processing and preservation (foldering; boxing; labeling; removing clips, staples, and other foreign objects; separating textual from non-textual materials; placing damaged or unstable documents into protective sleeves)
- description (including cataloging and the preparation of finding aids)
- access and use (including reference, exhibits, publications, and education)

Note: Each of these functions will be discussed in detail in its own section of this appendix.

Note: Never attempt to do any of the phases listed above before learning about the person, family, or organization that created the collection, and the history or other subjects covered in the collection.

11. *Why is it necessary to carry out these archival functions in the correct sequence?*

You should perform the archival tasks in the sequence listed above for several reasons.

- Before accessioning a collection, you should appraise it to determine whether it possesses sufficient value to warrant retention.
- Trying to use a collection before the important work of arrangement and description has been completed is difficult. You wouldn't have a finding aid or an arrangement scheme that could help you find the documents you need.
- Attempting to use a collection prematurely could interfere with the work of arranging, processing, and describing it. This would be like moving furniture and inviting guests into a room that's still being painted and carpeted.

Note: On very rare occasions you may have to use a collection that's still being processed. However, you must have a strong justification for doing so.

12. *Why is the arrangement of a collection necessary before cataloging?*

There's at least one sequence of archival tasks that's mandatory. Archival collections **must** be arranged before they can be cataloged. Description always follows arrangement.

Never attempt to catalog an archival collection before it has been physically arranged.

Archival cataloging and description are based on each collection's unique hierarchical arrangement. Therefore, you cannot begin to catalog a collection until you have completed arranging it. You must also have a good general sense of what's in the collection as a whole before beginning to catalog. You need to know the:

- physical types of documents
- information contained in those documents
- functions served by those documents

The best way to acquire this knowledge is through arranging and processing the collection.

Arrangement is the necessary preliminary work before cataloging. It can take a considerable amount of time. You can spend many days or weeks organizing and processing a collection before you can write a single catalog record. However, don't attempt to catalog archival materials before that preliminary work is done.

See Sections H-M for a full discussion of arrangement.

13. *How is cataloging an archival collection different from cataloging museum objects?*

You can't catalog archival materials in the same way that you catalog museum objects. When cataloging museum objects, you catalog one object or one small lot of objects at a time. Even with scientific collections, where it is important to classify objects and to document the relationships between objects, the result is still going to be one catalog record per object or one catalog record per lot. With non-scientific collection, where there may be little or no direct relationship between objects, it is possible simply to catalog one object at a time with no reference at all to other objects.

An archival collection, however, should never be cataloged on a document-by-document basis, as object collections are cataloged on an object-by-object basis. Instead, you have to create a single catalog record for an entire collection of archival materials (which might involve many thousands of documents). Then, you must develop separate archival descriptions for all series, subseries, or sub-subseries in the collection. If necessary, you can also describe individual file units or even individual documents.

Further, the cataloging and description of archival materials is based partly on how they are filed or housed. Object cataloging is not affected by the physical placement of the objects being cataloged. Even objects that were

collected as part of the same project or are otherwise related may be shelved, boxed, or stored in different locations. Apart from noting the physical location of each object or lot, a catalog record for an object will not be based on the object's physical placement. Actual physical arrangement, however, is central to archival cataloging.

Never attempt to catalog archival materials by cataloging one document, putting it back in the file or back in the box, and moving on to catalog the next document.

Archival cataloging is based largely on the physical arrangement of a collection. It is necessary to organize a collection into its hierarchical component—both physically and intellectually—so that you can describe those various components. Once the collection has been physically arranged, you will be able to describe the collection as a whole, then each of the series that make up the collection, each of the subseries that make up the series, and so forth.

Even though it can be time-consuming to complete the physical arrangement of a collection, the actual task of producing an archival catalog record can be done relatively quickly. A single catalog record may cover thousands of individual documents. These are counted as individual objects in the Collection Management Report. The time spent on cataloging and description is far less when you follow archival methods. This is true even if you complete series and subseries descriptions or container lists in the Archives Module.

Individual project files in archeology, paleontology, geology, biology, etc., can still be co-located with their associated objects at partner repositories even if the collection as a whole is arranged hierarchically. Just do a file unit description in the Archives Module, and note in the location field that the file unit is housed at another repository. If you do not already have an on-going agreement with that repository, you should also complete an Outside Loan Agreement. Even though the file unit is separated physically from the remainder of the collection, it is still part of that collection intellectually because it retains the same provenance as the remainder of the collection.

In short, don't attempt to catalog an archival collection on a document-by-document or file-by-file basis. Put all the pieces together in a hierarchical arrangement before cataloging.

E. Appraisal

This section outlines the criteria, standards, and methods you should employ to determine whether a collection is:

- historically significant, *and*
- eligible to be accessioned

1. *Why is it necessary to appraise archival and manuscript materials before accessioning them?*

For legal, professional, and practical reasons, it's unwise to accession all archival material that may be available. Just because documents are old doesn't necessarily mean they are worth keeping. NPS curators and archivists must apply specific criteria and make serious decisions about acquiring archival collections.

Federal records that must be retained by statute or because they are covered by an existing records disposition schedule don't need to be appraised. They are automatically eligible for accessioning (see Section F, "Records Schedules").

Example: Records associated with archeological projects at parks are covered by NPS-19, and Federal regulations require that they be retained. Therefore, you do not need to appraise them before accessioning them.

The Federal Records Act requires that certain types of park records be transferred to the National Archives. It would be inappropriate to accession such materials into NPS museum collections, no matter how valuable they are. The records schedule in NPS-19 provides clear guidance on this.

See Section F, "Records Schedules," for additional information on the Federal Records Act and NPS-19.

By applying good appraisal techniques, you can prevent museum collections from being inundated by:

- documents with minimal historical value that shouldn't be accessioned
- certain park records that are required to be sent by law to the National Archives

Appraisals prevent valuable NPS resources from being diverted away from legitimate museum holdings and activities.

Once archival collections are accessioned, it becomes very difficult to deaccession them. The items will be counted in the backlog and eventually will have to be processed and cataloged. The best deaccession policy is always a good accession policy.

2. *What are the two methods for determining whether a given collection of archival or manuscript materials should be accessioned?*

The two methods for determining whether you should accession archival materials are:

- Apply an *existing* "records schedule" to see if directions are already in place for handling this particular type of records. (**Note:** NPS staff apply existing records schedules to park records *only*. Records schedules don't apply to donated material.) See Section F for information on records schedules.
- Conduct an original appraisal of the materials in question. Evaluate the records according to several well-established criteria.

3. *How do I appraise donated materials?* You can't apply existing NPS records schedules to donated materials. Appraise each collection of personal papers or organizational records offered to your park. Follow the appraisal guidelines cited below in this section. Parks can appraise these kinds of materials completely on their own authority. You don't need to get authorization from the National Archives. See Section F for specific schedules covering NPS records.
4. *What are the guidelines for appraising archival and manuscript materials?* To qualify as a museum accession, a collection of archival or manuscript materials must:
- fit the park's Scope of Collections Statement, *and*
 - demonstrate enduring value in one or more of the following areas:
 - evidential value
 - informational value
 - legal value
 - intrinsic value
 - associational value
- Note:** The Scope of Collections Statement (SOCS) defines the museum objects and archival/manuscript materials a park will collect. Each park is required to have one. The SOCS reflects the park's mission. It focuses on museum objects and archival/manuscript materials that:
- relate to the park's cultural resources and natural history
 - relate to the site, subject, person, event, or other entity the park was established to preserve and interpret
- For further information on SOCS, see the *Museum Handbook*, Part I, Chapter 2.
5. *What's "evidential value"?* "Evidential value" documents the activities, goals, policies, programs, administration, and organization of the records creator. Such records constitute evidence of the actions taken or considered by the records creator.
- A collection of personal papers that reflects the activities and thoughts of the person who created it has evidential value.
6. *What's "informational value"?* An archival collection has "informational value" if it contains information on historical events, themes, issues, and eras apart from the organization or the person that created the records.
- The archives of the Olmsted Firm at the Frederick Law Olmsted NHS are an example. They document the company's activities (evidential value), but also contain informational value about the:
- evolution of landscape architecture and urban planning in the late 19th and early 20th centuries

- cities where the Olmsted Firm designed parks and thoroughfares

The records of the Calumet and Hecla Mining Company and the Quincy Mining Company at Keweenaw NHS document the activities of those corporations. The records also contain informational value by documenting the:

- history of the mining industry and labor relations in Northern Michigan from the 1880s through the 1930s
- political and social history of mining towns in that area

7. *How do I evaluate a collection's informational value?*

Most collections will have at least some trace of informational value. However, not all collections with informational value should be accessioned.

To warrant retention on the basis of informational value, a collection must contain information that is unique, concentrated, and important.

Unique Information

Information contained in a collection is unique if:

- it's not readily available elsewhere (such as, in books, or in newspapers, or in other archival collections), *or*
- the collection contains information from a particular perspective that is not available elsewhere

Concentrated Information

Information in a collection is concentrated if it presents:

- many facts on a small number of persons, things, issues, or events; *or*
- a few facts on a large number of persons, things, issues, or events; *or*
- many facts on a large number of persons, things, issues, or events

Note: Collections that contain only a few facts about a small number of persons, things, issues, or events may not be sufficiently concentrated to justify accessioning.

Importance of the Information

The collection should have importance as a potential information source. The information should be primarily important for the NPS and secondarily for outside historians, scientists, and other researchers. Don't accession collections that are of no use as a reference tool or source of information for the NPS or outside researchers or would be readily available at public libraries or other repositories.

8. *What's "legal value"?*

Documents such as deeds, wills, articles of incorporation, and contracts may

have ongoing “legal value.” Such documents may be necessary to establish ownership, authority, responsibility, or obligation in a legal sense. Documents with legal value may be important not only for historical research, but also for present-day and future activities, from title searches to litigation.

Note: For park records, most records with legal value are already scheduled in NPS-19 (Appendix B) for permanent retention. They are retained either in the museum collection or at the National Archives.

9. *What’s “intrinsic value”?*

Some documents have value not for the information they contain, but rather as artifacts. Documents that are important as artifacts have “intrinsic value.” An excellent non-NPS example would be the Declaration of Independence. Innumerable copies of the Declaration of Independence exist all over the world. The original Declaration of Independence is on permanent exhibit at the National Archives. It contains no evidence about the operations of the Continental Congress or information about the American Revolution that isn’t readily available elsewhere. However, the document itself, as a physical object, has tremendous artifactual or intrinsic value.

Intrinsic value is seldom a factor when appraising an entire collection. However, it’s an important consideration in determining how to handle individual documents. Some documents are physically unstable and may cause surrounding items to deteriorate. These include newspaper clippings or telegrams on pulp paper, nitrate-based photographic negatives, and motion pictures. If an item is exceptionally deteriorated, it’s permissible to replace the original with a surrogate archival quality copy. If the original lacks intrinsic value, you may discard it without having to formally deaccession it. If it has intrinsic value, you should keep it for as long as possible.

10. *What’s “associational value”?*

“Associational value” refers to a collection’s relationship to a person, organization, or event whose history the park preserves or interprets. For example, Golden Gate NRA preserves and interprets the history of the former U.S. Penitentiary on Alcatraz. Accordingly, that park has collected archival materials associated with Alcatraz.

Associational value alone is usually not sufficient to warrant accessioning. It’s basically the same thing as meeting the park’s Scope of Collections Statement. Collections must not only fit the Scope of Collections Statement or have associational value; they must also possess evidential, informational, or legal value.

“Associated records” are also documents generated through the collection or analyses of artifacts or specimens. They are necessary for the management and future research use of those artifacts and specimens. Examples include field notes and reports produced as part of permitted research projects at the park. These records are associated with archeological, paleontological, geological, or biological objects or specimens in the park’s museum collection. Check both the Scope of Collections Statement and NPS-19 (Appendix B) for information on associated records that should be accessioned.

11. *Are there other types of archival “values”?*

There are other types of archival “values”:

- “Monetary value” refers to the dollar value placed on rare or

collectable documents. It should seldom, if ever, be regarded as a criterion for accessioning. In other words, if a collection has sufficient informational or evidential value and fits the park's Scope of Collection, but has little or no monetary value, it should still be accessioned. If, however, a collection has monetary value but does not fit the Scope of Collection or has insufficient informational or evidential value, then it probably should not be accessioned.

- “Administrative value” refers to the usefulness of a collection of park records for purposes of park management. Resource management records, as defined in NPS-19 (Appendix B), may be scheduled for permanent retention in park museum collections because of their administrative value.

Note: For further guidance on the methods and objectives of records appraisal, see “Strategic Directions: Appraisal Policy” (NARA Directive 1441), at <http://www.archives.gov/records-mgmt/initiatives/appraisal.html>.

12. *How should a records appraisal be conducted and documented?*

Records appraisals should be conducted and documented as follows:

<i>If...</i>	<i>Then...</i>
you are simply applying an existing records schedule to a collection of park records,	you should indicate the specific schedule and item number in the accession file.
you are developing a specific records schedule,	you should draft an appraisal report (in the form of a memorandum) and complete National Archives SF 115, Request for Disposition Authority.
you are considering whether to purchase or accept the donation of an archival or manuscript collection,	you should draft an appraisal report (in the form of a memorandum) stating how the collection meets the Scope of Collections Statement and has sufficient evidential, informational, or legal value to be accessioned.

Note: The appraisal report should explain how the records have sufficient evidential, informational, legal, or administrative value to be accessioned. Follow the chain-of-command and procedures at your park to get the appraisal report and SF 115 approved. Then submit them to the National Archives for a final decision.

13. *What is the collections advisory committee, and what role does it play in appraisal?*

Each park is required to have a collections advisory committee to review proposed deaccessions and make recommendations to the superintendent. The committee may also review proposed accessions, although this is not mandatory. Although this is left to the park's discretion, it might be a good idea to have the collections advisory committee review any appraisal reports prior to accessioning. The superintendent, of course, makes the final decision on both accessions and deaccessions.

14. *When is it appropriate to conduct an archival survey?*

You should initiate an archival survey of possible storage areas to locate any records eligible for accessioning if:

- your park doesn't have an active records management program in place to identify park records that should be transferred to the custody of the museum program, *and*
- it's likely that resource management records are stored at various locations throughout the park (offices, workshops, basements, garages, attics)

Records surveys and records appraisals are best conducted by a qualified archivist or records manager. If one is not available at the park, you may want to hire a contractor or seek assistance from your regional office.

15. *What kind of information do I need to gather about any records I find?*

Gather enough information to make a decision whether or not to accession any records that you locate. See **Figure D.1**. The survey should include:

- information on the physical location where the records were found
- name of the park office or park employee who created the records
- overview of materials, including the type of documents (ledgers, correspondence, invoices, press releases, photographs, reports), volume, date range, and topics
- NPS-19 file code, if applicable

16. *Should I prepare folder title lists, full collection level or series level descriptions, or catalog records?*

No. In-depth descriptive work usually can wait until after the records have been accessioned. There's no need to prepare folder title lists or other detailed description for records that aren't eligible or appropriate for accessioning.

Simply follow the instructions under "Disposition,"

17. *If I identify records in my survey that fall under an NPS-19 file code, how should I handle them?*

<i>If...</i>	<i>Then...</i>
NPS-19 calls for records under a given file code to be accessioned into the museum collection after a certain date,	accession them at the specified time.
the disposition instructions specify that the records are "temporary" or "non-permanent," or if they indicate that records should be transferred to the National Archives and Records Administration.	don't accession them into the museum collection.

18. *What if I find NPS records that are not covered by a file code under NPS-19?*

Consult with the servicewide Records Manager. The Records Manager will advise you whether and how to submit a “Request for Disposition Authority” to the National Archives.

19. *What if I locate non-NPS archival materials during my survey?*

Ideally, any non-NPS archival materials acquired through donation, purchase, or other means would already have been appraised and accessioned. If your survey uncovers any non-NPS materials that haven’t been appraised and accessioned, you should:

- ensure that your park has legal title (one way to do this is to check the accession file to see if there is a Deed of Gift).
- appraise the materials according to the guidelines specified above to determine if they have sufficient evidential, informational, legal, administrative, or intrinsic value to warrant accessioning

F. Records Schedules

1. *What’s a records schedule?*

A records schedule is a set of directions for handling certain types of records that are likely to be created on an ongoing basis. In effect, a records schedule pre-appraises certain types of records. A records schedule will set forth directions for handling all records that fit into a specific category. The directions are based on a general assessment of how valuable any records in that category would be.

A typical records schedule will list one or more types or categories of records. The records schedule provides descriptions of the sorts of documents that would be included in those categories. See Table 2 for some examples.

Examples of Records Categories

[Please note: This list is not an all-inclusive; these are only examples]

Narrative Reports and Related Correspondence
Public Relations Files
Records of Conferences and Meetings
Special Events Files
Concessions Reports
Construction Programs Files
Maintenance Program Records
Roads and Trails Files
Contract Files
Budget Formulation Files
Land Use Files
Environmental Impact Records
Official Personnel Folders
Applications for Employment
Law Enforcement Reports
Fire Management Reports

For each record category, the records schedule provides instructions on the

disposition of those records. Examples of “disposition authorities” (or instructions) include:

- destroy when no longer needed
- hold for a specified time period, such as 5 years or 20 years, and then destroy
- hold for a specified time period and then transfer to the National Archives
- retain permanently at the park

Only records scheduled to be kept permanently at the park should be accessioned into NPS museum collections.

2. *What records schedules are available for use by NPS staff?*

NPS staff use the following records schedules:

- NPS-19 (Appendix B)
- General Records Schedules
- specific records schedules developed for individual categories of records at individual parks

3. *What's NPS-19 (Appendix B)?*

NPS-19 (Appendix B) is the Records Disposition Schedule for the National Park Service. It lists hundreds of categories of records in 12 general groups:

- Administration
- Concessions
- Development and Maintenance
- Fiscal
- History and Archeology
- Interpretation and Information
- Lands and Recreation
- Natural and Social Sciences
- Personnel
- Supplies, Procurement, and Property
- Laws and Legal Matters
- Fire Management

NPS-19 (Appendix B) is available on-line at:
<http://data2.itc.nps.gov/wapc/records/Index.html>.

It's also available via InsideNPS. Go to NPS Policies, click Records Management in the Select Policy Subject drop-down menu, and choose Records Management Intranet Web Site.

4. *How should I apply NPS-19 (Appendix B) to park records?*

Apply NPS-19 (Appendix B) to park records only (see definition, question 8 below).

<i>If...</i>	<i>Then...</i>
the records have been filed according to the filing codes provided in NPS-19,	you should compare the actual records to the appropriate code to confirm that they were properly filed.
the records were filed under the correct filing code,	follow the directions cited under "Disposition" for that particular code. Those directions will tell you whether you should: <ul style="list-style-type: none">• destroy the records after a certain period• transfer them to the National Archives• accession them into the museum collection
the records in question were not filed according to the NPS-19 filing codes, or if they were filed incorrectly,	review the filing codes to find the one that matches those records. Then follow the directions cited under "Disposition" for that particular code. Those directions will tell you whether you should: <ul style="list-style-type: none">• destroy the records after a certain period• transfer them to the National Archives• accession them into the museum collection
you are unfamiliar with the NPS-19 records codes and how to apply them,	consult with the park's administrative officer, the regional curator, or the NPS records manager.

Note: Certain file units—such as project files—may contain copies of documents with different filing codes. In such cases, leave the files intact.

5. *What's the General Records Schedule?*

The General Records Schedule is a collection of records schedules. It covers more than 20 broad categories of records that are commonly produced by Federal agencies. The National Archives and Records Administration (NARA) issues the schedule. It's available on-line at <http://www.archives.gov/records-mgmt>.

Apply the General Records Schedule to park records in the same manner that you would apply NPS-19 (Appendix B).

Most General Records Schedules relevant to the National Park Service have already been incorporated into NPS-19 (Appendix B).

6. *What are "specific" records schedules?*

You may discover park records that don't appear to be covered by either NPS-19 (Appendix B) or the General Records Schedule. Consult with your park's administrative officer to see if a specific schedule for those records exists. If there is a specific schedule, follow the disposition instructions. If there isn't a specific schedule covering those records, you'll need to get one.

7. *How can my park get a specific records schedule?*

To get a specific records schedule:

- Appraise the records in question, following the guidelines in Section E.
- Submit a "Request for Disposition Authority" to the National Archives and Records Administration. Provide the findings of your appraisal and propose a disposition (such as, destruction, transfer to the National Archives, or permanent retention at the park).

Note: The National Archives has legal authority over the disposition of all Federal records covered by the Federal Records Act. The Federal Records Act includes all NPS records. If you need assistance preparing a Request for Disposition Authority:

- check the National Archives website (<http://www.archives.gov/records-mgmt>), or
- consult with the NPS records manager

8. *Should NPS-19 (Appendix B), the General Records Schedule, or specific records schedules be applied to any kind of archival or manuscript materials?*

No. Records schedules can only be applied to records produced by the National Park Service.

NPS records include all materials such as reports, letters, memorandums, photographs, sound recordings, films, floppy disks, CDs, maps, blueprints, videotapes, and any other kind of document filed in the course of official business. NPS records also include materials from outside sources that a park receives in the course of doing business. Some examples are letters written to park officials and contract proposals sent to the procurement office.

9. *Should NPS-19 (Appendix B), the General Records Schedule, or specific records schedules be applied to donated or purchased materials?*

No. Donated or purchased materials, such as personal papers and the records of non-federal organizations are not Federal records. Federal records schedules don't apply to them.

G. Accessioning Archival Materials

1. *When should I accession a collection of archival or manuscript materials?*

As detailed in Section E, you should accession archival or manuscript materials only after determining that the materials in question:

- meet the Scope of Collections Statement, *and*
- have sufficient historical value to justify permanent retention

Use one of the following methods to determine whether you should accession collections:

- For park records: Follow guidelines contained in NPS-19 (Appendix B).
- For park-generated documents that aren't considered official records: Appraise the materials to determine if they have evidential value, informational value, legal value, or administrative value. Include findings in a written appraisal report.
- For donated or purchased materials: Appraise the materials to determine if they have evidential value, informational value, or legal value. Include findings in a written appraisal report. **Note:** Only a qualified archivist or records manager should attempt to do an appraisal report.

2. *What steps should I take to accession an archival collection?*

Take the following steps to accession an archival collection:

Follow the accessioning procedures outlined in Museum Handbook II, Chapter 2, Accessioning. The same basic procedures and rules for accessioning museum objects also apply to accessioning archival collections.

- For donated materials: Have the owner sign a Deed of Gift (Form 10-830). Always ask for all copyrights when conveying title to the NPS, and get signed release forms.
- For purchases: Have an appropriate purchase document and statement of ownership. Always ask for all copyrights when purchasing collections for the NPS, and get signed release forms. **NPS policy states that donations or purchases of archival materials should be made without restrictions** (although exceptions may be made in certain cases).

- For materials from another park or Federal agency: Complete a Transfer of Property Form (DI-104).
- For records associated with field collections (such as field notebooks of archeologists, paleontologists, geologists, and biologists conducting research under NPS permit): Complete a Receipt for Property Form (DI-105).
- For materials acquired via loans: Complete an Incoming Loan Agreement and Receipt for Property (DI-105).

Note: It's permissible to accept copies of field notes and similar materials produced by outside researchers. See *Museum Handbook III*, Chapter 2 for information on copyright issues for field notes.

3. *Does each document have to have an accession number?*

No. Archival materials generally are accessioned in bulk. However, under certain circumstances it's possible for accession numbers to be assigned to individual items within a collection.

4. *Does each collection have to have a single and unique accession number?*

This is *preferred*, but isn't mandatory. There may be occasions where a single accession can contain materials from multiple collections. There may be occasions when a single collection may be acquired in multiple accessions. It's simpler and more efficient to handle archival materials when a single accession represents a single collection in its entirety, if at all possible. In defining an archival collection, however, the overriding factor is provenance—not the accession.

You should never intentionally combine multiple collections in a single accession – but sometimes this can happen by mistake. Example 3, below, provides guidance on what to do if you should encounter an accession combining two or more collections.

Example 1: The personal papers of a particular individual are donated to the park by that person's descendants, and receive an accession number. Then the family discovers an additional cache of that person's papers, and donates them, too. Because the park didn't receive these papers until many years after the initial accession, the new donation receives its own accession number. But the two accessions should be combined under a single catalog record because they are two parts of a whole: the personal papers of the individual who created them.

Example 2: All Resource Management Records for the park are being handled as a single collection (see Section M for more information on how and why this should be done). This collection contains several "recurring series," which are on-going series of records that will grow over time with the addition of new file units. New file units for these various series, such as "Grazing Records" or "Fire Management Records," should be given new accession numbers as they are received, but they should simply be added to the existing collection. Therefore, this collection of Resource Management Records may receive an infinite number of accessions over the years, but it will remain a single collection.

Example 3: The park receives a donation of archival materials as a single

accession. Upon further examination, it appears that the accession contains the personal papers of two different individuals. The accession therefore contains two distinct collections and should be split between two catalog records—one for each collection.

5. *Can accessions be divided?*

Yes. It's conceivable that multiple collections can get mixed together in a single accession. For example, a park may acquire two or more collections from a single donor and handle the donation as a single accession. When that happens, it's necessary to separate the different collections and then catalog and shelve each of them separately. If an accession contains three different collections, enter them into the ANCS+ Collections Management Module as three different catalog records. The same accession number should be cited in all three catalog records.

The most important unit in archives and manuscripts is the collection, not the accession or the individual document.

6. *Can multiple accessions form a single archival collection?*

Yes. It's not uncommon for a collection to be acquired by a park in two or more accessions. Sometimes collections can be acquired through many small accessions over a period of many years. This is particularly true for ongoing or recurring series, such as Resource Management Records, which will be produced as long as the park continues to exist. Although *cataloged* Resource Management Records will always have an end date, that end date will always be subject to change as you accession more recent records. (See next question, "What's an 'accretion,?'" for more information on adding new accessions to existing collections.

When a single collection is broken out among multiple accessions, the collection needs to be reassembled. It's necessary to combine all of the accessions and handle the collection as a single item. Enter the collection into the ANCS+ Collections Management Module as a single catalog record. All of the accession numbers for that collection, however, should be cited in that catalog record.

7. *What's an "accretion"?*

"Accretion" is another name for an accession that is added to an existing collection that has already been cataloged.

It's not unusual to receive additional materials belonging to a collection after the collection has been arranged, shelved, and cataloged. For example, a donor could transfer all the papers of a famous ancestor to the park. Years later, he or she discovers another portion of that collection. In such cases, the donor might transfer the remainder of the papers to the park long after the original accession had been cataloged.

In another example, most parks accession field notes and other associated records relating to permitted research. The associated records for archeology or geology might each constitute a collection. They might also each constitute a series within a larger collection of Resource Management records. Unless parks discontinue permitted research, associated records will continue to be accessioned. In most cases, treat these records as accretions to the existing series or collections. Don't treat each new accession as a new collection.

8. *How should I handle accretions to a collection?*

Interfile accretions with existing materials or add them to the collections as a new series, depending on the arrangement of the collection. See Sections H, I, and J for additional information on how to arrange collections.

Update the existing catalog record by:

- adding an additional accession number for the accretion
- updating the volume of the accretion to the volume of the collection as a whole
- updating the date range for the collection if the accretion covers years beyond those covered in the existing collection
- revising the description field if the accretion covers subjects not noted previously and types of documents not previously listed
- revising the organization/arrangement field to show an additional series if the accretion is being handled as a new series within the collection (Remember to complete a new series screen in the Archives Module.)

H. Arrangement

Once you have accessioned a collection, the next step is to arrange it in its proper order. There's no universal template that can be used when arranging a collection. However, there are clear and fairly simple rules and standards that you must follow.

1. *What's arrangement?*

Arrangement is perhaps the most important step in managing an archival or manuscript collection. Arrangement is the process by which a collection of any size is brought under both intellectual and physical control. The way in which a collection is organized becomes the basis for all subsequent activities or uses in connection with that collection. Effective cataloging and access is possible only if a collection has been arranged. An unarranged collection cannot be cataloged properly or used efficiently.

Never attempt to catalog a collection until it has been arranged.

2. *Why is it necessary to arrange a collection before cataloging or using it?*

The "collection," not the individual document or file, is the basic unit of control in archives. A collection, regardless of size, represents a single grouping of items that's documented on a single catalog record.

Although an entire collection should be cataloged in a single catalog record in the Collection Management Module, you cannot stop there. For most archival collections, proper documentation requires description of the lower levels of the collection's hierarchy—such as the individual series and subseries—in the Archives Module. These descriptions are based on the actual arrangement of the collection. The catalog record, therefore, documents only part of a collection. For full documentation of a collection, you need to enter descriptions in the Archives Module.

Remember that a collection contains *ALL* historically significant documents in the park's custody that were created or received by a particular

organization or individual. If the park has 100 folders of documents created or received by an organization (such as a corporation, a non-profit foundation, or a government agency), then treat all 100 folders as part of a single collection. Do not handle each folder as an individual collection.

To make sense of a collection, it must be arranged. All but the smallest collections typically are subdivided into series. The series may be further subdivided into subseries and sub-subseries, which typically are subdivided into file units. Each document has a permanent location in this structure of series, subseries, and file units. The structure is similar to a book in which each page has a permanent location within a chapter. Otherwise, a collection would be nothing but a chaotic jumble of disconnected documents. There would be no logical order, no context, and no way of locating information except to search each document, one at a time. It would be like a book that is bound without regard for pagination.

Put another way, an unarranged collection is like a disassembled puzzle. To make the collection manageable and useful, you have to put the pieces together. Only then will the full picture become apparent. Trying to catalog a collection before arranging it would be like trying to describe the picture before assembling the puzzle. Trying to do reference in an unarranged collection is equally inefficient. It's like trying to find a particular scene in a thousand-piece puzzle by sorting through the loose pieces.

Fortunately, most collections will be in at least rough order when they are accessioned. Some collections may have been mixed up between the time they were created and the time they were accessioned. However, there are many clues and guidelines to help you put a collection back into its original order.

3. *What are the two key steps that I have to take in order to arrange a collection?*

The two key steps to arranging a collection are:

- *Define the Collection.* Clearly identify what materials are in the collection. In most cases, a single collection would include all documents created or received by a particular person or organization. Make sure the collection remains intact and is not mixed with any other collections.
- *Establish the Internal Organization of the Collection.* Determine if the collection is ordered correctly, or if you need to put it back into its correct order.

4. *How do I handle items that pertain to more than one collection?*

A collection consists of all documents created *or received* by a particular person or organization. Although some documents may pertain to other collections, all documents must be kept as part of that person's or organization's collection.

For example, you have a collection of George Washington's papers and a collection of Thomas Jefferson's papers. The Thomas Jefferson papers include an original letter that George Washington sent to Thomas Jefferson. Even though Washington wrote the letter, he sent it to Jefferson, who kept it in his own collection. Therefore, the letter becomes part of Jefferson's records, not Washington's. If Washington kept a copy of the letter for his own collection, however, that copy would properly be part of the Washington Collection.

5. *May I combine similar or related collections?* No. Never mix one collection with another collection, no matter how closely related they might appear to be. Two collections of records that cover exactly the same topics created by two different organizations are two separate collections.
6. *May I break collections up into multiple collections if they are very large or cover different topics?* No. You should never break up a collection. You may subdivide the collection into series and subseries and thereby address questions of size and subject. Those are internal or organizational divisions. The collection as a whole should remain intact and should be handled as a single catalog record.

One exception to the rule against breaking up collections into smaller collections involves associated records. You may treat all project files for a particular discipline as a collection, rather than as a series within a larger collection of park resource management records. Do not, however, treat individual project files as separate collections.

7. *Should I combine archival materials created by an individual while he or she was working for an organization into a collection with materials created by that same individual in his or her spare time?* No. It's best to keep an individual's personal papers separate from documents he or she created while working for an organization or agency. For example, your park has the archives of an organization that includes the speeches and business correspondence of the organization's president. In addition, your park has that individual's personal correspondence and diaries. You should keep the documents created by that person in his or her official capacity as president of the organization with the organization's archives, and you should manage that person's private papers as a separate collection.

8. *Should each accession be regarded as a collection?* Not necessarily. It's possible that:
- a park could acquire an entire collection as a single accession
 - a park could acquire an entire collection through multiple accessions, sometimes spread out over several years
 - a single accession may contain more than one collection, or portions of more than one collection
 - the park may acquire a portion of a collection in an accession that is received *after* that collection has been cataloged (In such cases, add the new accession to the rest of the collection and revise the catalog record accordingly.)

Note: See Section G for a more detailed explanation of how to accession archival collections.

9. *What's meant by "archival arrangement"?* Any collection of archives or manuscripts is going to be arranged in some manner. The arrangement patterns of larger collections may be fairly complex, but the overall concept of archival arrangement is a simple one.

As individuals or organizations create and save records, they seldom do so in a random manner. They usually don't keep loose documents in boxes or drawers without some kind of logical arrangement or filing system. Instead, they place documents into folders. Then they may group the folders based on subject, function, source, or document type.

For example, staff members in an office start working on a particular project. They are likely to open a file on that project. All of the letters, reports, notes, meeting minutes, and reference documents concerning the project would go into that file. The file, in turn, would be kept together with files on all of the office's other projects. These project files would be kept together in the same file drawer. There would be some kind of logical scheme for arranging them. They might be arranged alphabetically by the official title of the project or numerically according to an established filing code.

The office might also keep "reading files" containing copies of all outgoing correspondence. One way of handling these documents would be to open a new reading file every month. Staff would place copies of outgoing letters into that file as they are completed. All the monthly files would be kept together in the same file drawer. Similarly, as invoices are received from vendors, all of the invoices would be filed together. They could be filed in alphabetical order, by the name of the vendor, or in chronological order, by the date received.

An archival arrangement usually is nothing more than the basic structure that a person or organization adopted when filing records.

You could walk into almost any NPS office and quickly see that certain types of files are kept in one drawer. Other types of files are kept in other drawers. Those varying groups of records in the different drawers are like series in an archival collection. Each series—the project files, the reading files, the invoices, etc.—consolidates a group of files by type or function, and arranges them in a consistent pattern (alphabetically, numerically, chronologically, etc.).

10. *Should all archival or manuscript collections follow the same arrangement patterns?*

No. Each archival or manuscript collection will have a unique structure. All archival collections, however, follow the same "bigger to smaller" format. The goal is to keep the order in which the collection was originally kept. But the actual components and filing schemes will vary from collection to collection.

Some collections may be nothing more than a group of individual documents or individual file units. More commonly, however, individual documents or file units are organized into series or subseries. The file units or individual documents in some series or subseries may be arranged chronologically, whereas file units or individual documents in other series or subseries may be arranged alphabetically. There is no standard template. It all depends upon the specific collection because each collection will have its own unique organizational structure. For examples of variations in hierarchical structures for one category (park resource management records), see **Figure D.4a-D.4g**.

Arrangement patterns will vary based on any number of factors, such as:

- the work a person or organization does
- the size and complexity of the organization that created a collection of records
- individual preference for types of filing schemes and formats (certain

organizations or individuals may produce certain physical types of records that they choose to file together.)

Example: Type of Work

The records of the Thomas Edison Corp. at Edison NHP, include laboratory notes. The notes reflect the fact that the corporation was engaged in original research. The records of American President Lines at San Francisco Maritime NHP include ships' logs. The logs reflect that company's activities as a shipping line. A person or organization's specific activities or functions help determine the kinds of records they create. The activities and functions also determine the internal structure or arrangement of their archival collections.

Example: Size and Complexity

A small company may have one central filing system. It would keep all of its correspondence files together, all of its project files together, and all of its purchasing files together. A very large organization may be broken down into several components. Each component would have its own filing scheme. The arrangement of that organization's archival collection might therefore be broken out by the various organizational units. It would then be further broken out by the specific types of records that those units maintained.

Example: Individual Preference

Some individuals or organizations may keep financial records in bound ledgers. Others may keep financial records on loose sheets in file folders. Some may choose to arrange a particular type of material alphabetically. Others may choose to arrange a similar type of material chronologically or according to an alpha-numeric code.

Example: Types of Records

An organization may choose to file physical types of records together, such as architectural drawings, engineering drawings, maps, photographs, sound recordings, or motion pictures.

One of the most critically important responsibilities of the archivist or curator is to examine each individual archival or manuscript collection very carefully. The archivist or curator must be able to:

- ***discern a collection's specific and unique arrangement scheme***
- ***figure out how a collection was originally filed by the person or organization that created it***

11. *How can I determine original order if the collection has gotten out of order over the years?*

Use common sense, ordinary logic, and a basic familiarity with archival principles to determine the original order. See Section D for the archival principles that you will need to understand.

There are two key points to keep in mind:

- First, many collections will still be in their proper, original order when they're accessioned. All you have to do is identify that order and then maintain it. What are the main groupings of records? How are the files arranged within those groupings? If a file from one obvious grouping has gotten misplaced in another grouping, put that file back where it belongs. Draw up a "hierarchy" based on the order that you have identified (see Sections C and I for an explanation of a hierarchy.) Base your processing and cataloging of the collection on the way in which the collection is ordered.
- Second, there are many clues and guidelines that can easily help you put a mixed-up collection back into its original order (see item H-13, below, for examples).

You have to put the collection back together before you can proceed with any other tasks related to that collection. It's almost impossible to process, catalog, or use a collection effectively if it's not properly arranged.

12. *Is it okay to alter original order to suit current needs?*

No. If you can establish a collection's original order, then you must keep it. Even if there may seem to be a better way of organizing the collection, you must maintain the original order. There are several reasons for this.

The "original order" reflects how the records were filed. It also reflects the historical events and the historical contexts that they document. The original order is evidence of what actually happened, just as much as the documents themselves. Keeping a collection in its original order can help researchers discern:

- causes and effects
- responses to events
- the mindset of individuals at the time those events occurred
- the flow and patterns of history

By reordering a collection into what might seem like a more useful arrangement, such as topics that seem important at the time, you're imposing a subjective order on the records. This could make it more difficult for others to use the records in the future.

13. *Is it possible to arrange a collection that's no longer in its original order?*

Yes. Even if a collection gets all mixed up before it's accessioned or processed, it's usually possible to put it back into its original order. For example, mix up 26 volumes of an encyclopedia (arranged alphabetically), a ten-year run of a weekly magazine (arranged chronologically), and a set of financial ledgers (arranged by volume number). No matter how mixed up they are, it's easy to see that the encyclopedias belong together. The magazines belong together, and the ledgers belong together. It's equally easy to see that the encyclopedias should be in alphabetical order. The magazines should be in chronological order, and the ledgers belong in numerical order. Putting a disarranged archival collection back together is similar.

To determine original order, look closely at:

- arrangement schemes
- physical formats
- subject matter and function
- time frame
- source
- titles on file folders and bound volumes

For example, suppose you have 26 big bound volumes scattered throughout a collection. The volumes all carry the same title. Each volume is marked with a letter from A to Z (with none of the letters being repeated). The volumes all contain the same kinds of documents and information. Bring all of those volumes together as a series or subseries, and arrange them alphabetically. See Section J for information on series and subseries.

Similarly, suppose that hundreds of file folders labeled “Outgoing Correspondence” are also scattered throughout that collection. Each file folder is marked with a month and a year between 1937 and 1952. No month or year is repeated. The content of these file folders matches. All of the folders contain carbon copies of outgoing letters. The folders may be badly scattered through the collection. They may be jumbled with file folders containing different titles and are no longer in chronological order. However, they all appear to be part of one series. You should consolidate them and arrange them chronologically.

Figure D.2a is an example of a collection whose individual file units have gotten out of series order. **Figure D.2b** shows the hierarchy for that same collection upon being reassembled into its original order.

14. *What if the original order is hopelessly lost, and there is no way of re-establishing it?*

You must do everything you can to understand and preserve a collection’s original order. If the original order cannot be discerned, or if the original order was purely random, then the archivist may impose an order to make the collection useable. This should not be attempted except in extreme situations. If you have to impose an order on a collection, you should observe the following guidelines:

- Retain the provenance—that is, make sure that you are working with a single collection. Do not mix the collection with materials produced by another records creator, and do not divide the collection into multiple collections.
- Exert every effort to discern the original order. Do not attempt to impose an order unless you are certain that the original order cannot be ascertained or cannot be used even if it were ascertained.
- If at all possible, retain series and subseries structures. Confine yourself to reordering file units or documents within the original series organization.

Note: The decision on whether to impose order on a collection whose original order cannot be established should be made by a qualified archivist or records manager.

If a collection is out of order, it's not acceptable to leave it that way. Don't box, shelve, or catalog it in that condition.

I. Hierarchical Structure

1. What's a "hierarchy"?

The "hierarchy" is the internal structure of a collection. It shows how a collection is organized into its subordinate parts (series). It shows how series are organized into their subordinate parts (subseries). It shows how file units in series or subseries are arranged. It is like an outline of the collection or a table of contents. By surveying and arranging a collection, the collection's archival "hierarchy" will be identified. See Section D for additional information on hierarchies.

2. Why is hierarchical structure the key to arranging a collection?

The key to arranging an archival collection is to build from the top down. Begin with bigger elements and move down to their smaller components.

In other words, an archival collection should be arranged *hierarchically*. The top level of the hierarchy is the largest part of the hierarchy. This is the collection as a whole, which is all-encompassing. The bottom of the hierarchy is made up of the smallest parts of the collection or the individual documents themselves. In between, in descending order, would be the series, subseries, and file units.

The vast majority of collections are broken up into *groups* of archival materials. These groups are called "series." Each series, in turn, is broken down into components. In some cases, a series is broken down into smaller groups, called "subseries." In other cases, series are broken down into individual file units. Following the same pattern, these subseries may be broken down into yet smaller groups called "sub-subseries." They may also be broken down into individual file units. Each file unit, meanwhile, will contain one or more individual documents (or "items").

Looked at from the bottom up, this means that each document will belong to a file unit. Each file unit will belong to a subseries. Each subseries will belong to a series, and each series will belong to a collection.

The internal structure of an archival collection is not unlike the internal structure of the *Museum Handbook*. For example:

- An archival collection may be divided into *series*. The *Museum Handbook* is divided into *volumes*.
- An archival series may be divided into *file units*. Each volume of the *Museum Handbook* is divided into *chapters* and *appendices*.
- An archival file unit is divided into individual documents, or "*items*." The chapters and appendices in the *Museum Handbook* are divided into *sections*.

You can take the *Museum Handbook* out of its binders and shuffle the pages.

However, you can still put it back together in its original order. Similarly, if individual documents and file units in an archival collection get shuffled, it's still possible to put them back in their original order.

3. *What should a hierarchy look like?*

Figure D.3a shows a sample hierarchy for a collection of organizational archives. **Figure D.3b** shows a sample hierarchy for a collection of personal papers. Both hierarchies show how collections may be subdivided into series. They also show how some of those series, but not all of them, may be further subdivided into subseries and sub-subseries. The sample hierarchies show how subdividing into series, subseries, and sub-subseries may be based on:

- differences in the physical format of documents
- the type of documents
- the content or function of documents
- the origin of documents
- the filing or arrangement schemes

Most importantly, the sample hierarchies show how the different components in a collection relate to each other. Every element in a collection is part of a larger element. An item is part of a file unit, a file unit is part of a series, and so forth.

It's important to remember that these hierarchies are only examples, not templates. You should not simply try to force collections in your custody into these sample hierarchies. Each collection will have its own hierarchy, based on what the collection actually contains and how it's actually structured.

Identifying a hierarchy is not like classifying an object. You are not trying to place each document or each file within a taxonomic structure. Instead, you need to identify a collection's unique components. Identifying a hierarchy is nothing more than identifying a collection's internal structure. It all depends on how a collection is organized and how the documents are filed, which will be as different for each collection as the table of contents is different for every book.

4. *How should the various elements in the hierarchy (such as series, subseries, file units) be titled?*

Each element should have a unique title.

- No two collections among your holdings should have the same title. Never use generic titles when naming collections, such as "Associated Project Documentation." Indicate the creator of the records and the type of materials, such as: "Thomas E. Edison Papers" (the records creator is Thomas E. Edison, and the materials themselves are personal papers) or "Records Associated with Archeological Projects at Andersonville NHS" (the records creator is Andersonville NHS, and the materials themselves are archeological project files).
- Within a particular collection, no two series should have the same title.

If you have two very similar series, find some way to differentiate between them. For example, if you have a series of subject files covering the years 1920-1940 and a series of subject files covering the years 1941-1960, you can differentiate them in the titles as follows: “Subject Files, 1920-1940” and “Subject Files, 1941-1960.” Do not just put “Subject Files” in the title fields for both series. (Of course, it is all right to have a series entitled “Subject Files” in one collection and a series entitled “Subject Files” in another collection. Because the two series are in different collections, there is no conflict).

- Within a particular series, no two subseries should have the same title.
- Within a particular series or subseries, no two file units should have the same title. (Very large files can be contained in multiple folders, all of which would have the same title, but they are still all part of the same file unit. Example: You have a series of “Accounts Receivable” files that are arranged chronologically. The file unit for “Accounts Receivable – March 1938” is so voluminous, however, that it needs to be broken out into three separate folders. But these three folders all are part of a single file unit, so it is okay to put “Accounts Receivable – March 1938” on each of them. In such cases, they should be numbered “1 of 3,” “2 of 3,” etc.)
- Within a particular file unit, each document should have a unique title. If you are doing item level description—which is strongly discouraged—do not just identify individual items with a generic title such as “Letter” or “Memorandum.” Indicate what the document actually is, such as “Final Report of the Planning Committee, August 13, 1905” or “Letter, Smith to Jones, December 5, 1915.”
- Through a hierarchical approach, every series, every subseries, every file unit, and even every item will have a unique and permanent intellectual address. This is essential for managing, retrieving, and citing documents. For example, there can be only one document with the following intellectual address: “Fred Smith Papers: Correspondence: Outgoing Letters: December 1915: Smith to Jones, December 5, 1915.” This intellectual address clearly identifies the item (“Smith to Jones, December 5, 1915”), the file unit (“December 1915”), the subseries (“Outgoing Letters”), the series (“Correspondence”) and the collection (“Fred Smith Papers”).

Note: This unique hierarchical address method works, even if you only describe a collection down to the series or subseries level. If someone requests a copy of the letter from Smith to Jones, December 5, 1915, you do not need to have that individual letter described in the Archives Module in order to find it. If you have the series and subseries descriptions entered into the Archives Module, however, you will know where to find the letters that Mr. Smith sent out. You can just go to the box containing the outgoing letters for 1915. Thumb through the files until you come to the “December 1915” file, and flip through the letters until you come to the one you want. It is like looking up an article in an encyclopedia. You don’t need to know the exact page where the article is printed. All you need to know is the alphabet and where the set of encyclopedias is located.

*For further information on naming conventions and other standards for archival description, you may want to consult the Society of American Archivists' publication **Describing Archives: A Content Standard (DACS) (2007)**, or its predecessor volume, **Archives, Personal Papers, and Manuscripts (1989)**, by **Steven L. Hansen**.*

5. *How should a hierarchy be used?*

Once you have established a hierarchy, you have a blueprint for all future work involving that collection.

Processing and Arrangement Phase

As you process and arrange a collection, the hierarchy serves as your guide for putting documents and files into their proper order. The physical storage of the collection will reflect the hierarchical structure. Box and shelf series and subseries in the same order as they appear in the hierarchy.

Cataloging Phase

As you catalog a collection, you base your descriptions on the different levels of the hierarchy. You write a brief overall description of the collection as a whole. You then write similarly brief descriptions of each series, subseries, sub-subseries, and so forth. Generally, you should avoid individual descriptions of file units and items. See Sections R and S for further discussion on how to catalog archival and manuscript collections.

Reference and Document Search

As you conduct reference and search for documents in a collection, the hierarchy serves as the roadmap. It's the basis for the development of finding aids.

J. Organization—Series And Subseries

1. *What's a "series"?*

A "series" is a "natural" grouping of records. It's natural in the sense that the person or organization that created the records devised the groupings. The creator grouped the records mainly for ease of retrieval.

2. *How are series grouped?*

Series are grouped based on one or more of the following elements:

- *Arrangement Scheme:* A series should reflect a single arrangement scheme throughout. All the files, volumes, or documents within a series should be arranged alphabetically, chronologically, numerically, or according to some other consistent pattern.
- *Physical Type of Document:* The creator of a particular collection of records may have filed all the photographs together, or all the architectural drawings, or all the maps together. If so, these groupings by physical type might each constitute a series--but only if that is the way in which they were originally filed. If the records creator filed photographs together with letters and reports in a single series, then those photographs must remain part of that series—even if you have to separate them physically for preservation purposes (see Sections P and Q for more information on the physical removal of oversized

documents and photographs from textual series; also see the “If-Then” table under item 8, below).

- *Subject Matter or Function:* The records creator may have filed all the personnel files together. All the project files or all the financial records may be filed together. Series breakdowns typically reflect this kind of division.
- *Time Frame:* Certain types of records may be broken down into series by time periods. For example, a collection of correspondence may be arranged alphabetically by the name of the correspondent and grouped into blocks of 10 or 15 years. It may make sense to leave those blocks of correspondence intact as separate series. Grouping the records by time period might be better than attempting to interfile them with alphabetized correspondence from a subsequent 10-year period.
- *Source:* It’s conceivable that a group of documents received from a particular source could constitute a series. For example, a collection of financial records may consist of account statements, financial reports, correspondence, and cancelled checks received from different banks. These materials could be organized into one series per bank.

Note: People and organizations that create collections of records usually file their documents in a logical format. They keep certain types of documents together in a consistent filing scheme. For example, a filing cabinet may have one file drawer containing Project Files. A second file drawer could contain Correspondence Files, and a third file drawer might contain Invoice Files. Each of those components would be a series. Identifying the various series in an archival or manuscript collection should be as simple as identifying the drawers in the filing cabinet.

3. *What’s a “subseries”?* A “subseries” is a series within a series. Sometimes it’s appropriate to break a series up into smaller groups called subseries.
4. *When is it appropriate to have a subseries?* There are many reasons why it may be appropriate to break up a series into two or more subseries. Here are the most common reasons:
 - different arrangement patterns
 - different time periods
 - different physical formats
 - different sources or different types of records

Different Arrangement Patterns Example

Suppose all the correspondence files for a particular collection are kept together. This would constitute a single series. Within this series of correspondence files, however, the incoming letters are arranged alphabetically by name of correspondent. The copies of outgoing letters are arranged chronologically. You cannot have a series in which some of the file units are arranged alphabetically and some are arranged chronologically. Subdivide this series into two subseries. One subseries is for the alphabetically-arranged incoming letters. The other subseries is for the

chronologically-arranged copies of outgoing letters.

Different Time Periods Example

Suppose the records-creator filed incoming and outgoing letters together, arranged alphabetically. Then suppose that the person or organization that created the records stopped adding to this body of correspondence after 10 years. The individual placed it in storage and then started a new batch of alphabetically arranged correspondence that would run for the next 10 years. The archival collection would have two separate 10-year blocks of alphabetically arranged correspondence files. All of these correspondence files properly constitute a single series. However, it wouldn't be practical to try to integrate them into a single alphabetized group of files. Instead, break the series into two subseries--one for each 10-year block of records. To avoid confusion, be sure to include the beginning and ending dates of these subseries. Enter the dates in the date fields when you catalog the records. You should also incorporate the dates into the formal titles of the subseries: "Correspondence Files, 1960-1969" and "Correspondence Files, 1970-1979."

Different Physical Formats Example

It's not unusual for a group of photographs to constitute a series within a collection. But good records preservation practice calls for prints and negatives to be housed separately. Moreover, it's not unusual for prints and negatives to have different arrangement schemes. Prints are likely to be filed by subject and negatives by image number. In such cases, it's appropriate to subdivide a series of photographs into two subseries. Create a subseries of prints and a subseries of negatives.

Different Sources or Different Types of Records Example

An organization that creates a collection of archival materials may do so along administrative lines. It may file all of the correspondence together. It may file all of the personnel records together and all of the project files together. It would then subdivide them according to the division of the organization that created them. The Correspondence Files could be broken down into groupings such as the President's Office, the Research Division, and the Publications Division. In this case, the basic types of records--Correspondence Files, Personnel Files, and Project Files--would all be handled as series. Then each of them would be sub-divided into subseries for each of the organizational units. Alternatively, all of the records of each organizational unit could be filed together. There would be three series: President's Office Records, Research Division Records, and Publications Division Records. Those series, in turn, would be subdivided into subseries for each records type. For example, the series of Research Division Records would be broken down into subseries. There would be three subseries: Correspondence Files, Personnel Files, and Project Files.

5. *What's a sub-subseries?*

Just as a subseries is a series within a series, a sub-subseries is a series within a subseries. Not all collections in NPS custody will reach that level of complexity. However, it can happen, and it's just as easy to identify a sub-subseries as it is to identify a subseries.

Suppose the records of an organization were divided by administrative unit.

The records of the Research Division would constitute a series. The series would be subdivided according to type of records. The series might include a subseries of photographs. That subseries of photographs would likely be subdivided into a sub-subseries of negatives and a sub-subseries of prints.

It's even possible to go down to the sub-sub-subseries level. Suppose the sub-subseries of prints in the preceding example were subdivided. One group of prints is arranged by subject. A second group of prints is arranged by the name of the photographer. Each of those subdivisions would constitute a sub-sub-subseries.

6. *Why is it necessary to keep dividing and subdividing archival collections?*

You need to subdivide a collection until you have consistent bodies of records. A consistent body of records is the same kind of records arranged according to a single arrangement scheme.

7. *When should I stop subdividing?*

When a series or subseries or a sub-subseries consists of chronologically arranged correspondence files, you can stop subdividing, or when you have a series or subseries of personnel files that are arranged alphabetically, you can stop subdividing. If you have a group containing any other mismatches of record types or arrangements, then you need to continue subdividing. For example, if you have a series of alphabetically-arranged project files and numerically arranged ledgers, you should divide it into two subseries.

In most cases, you will not have to subdivide beyond the series or subseries level. In some cases, you will not have to subdivide. All of the files in a collection may contain the same type of material and follow a single arrangement pattern. Subdivide collections into series and subseries (and additional lower levels) only as necessary. Subdivide only to group bodies of like records in a single arrangement scheme.

8. *Should all items in a particular physical format be consolidated into a single series or subseries?*

Not necessarily. Only consolidate items of a particular format into a single series or subseries if the records creator originally filed them that way.

<i>If...</i>	<i>Then...</i>
the records creator kept all photographs in a set of albums,	those albums would constitute a single series or subseries.
the person or organization that created the records filed photographs with other types of materials, such as attachments to letters, or as illustrations for reports,	they are a permanent part of those letters or reports and would not constitute a separate series. Even though they should be separated <i>physically</i> for preservation purposes (see Section Q), <i>intellectually</i> they remain part of the file in which they originally were kept.

Don't store records with different formats together because they can damage each other.

Photographs that are kept next to letters, for example, can damage the fibers and inks in the letters. The fibers and inks in the letters can also damage the

photographs. In such cases, you have two options. First, you may place the photographs into protective sleeves, and leave them in their original location. If this is impractical (because of the photographs' sizes, volume, or condition), then they should be physically removed and stored separately from the letters. Place a separation sheet where the photographs were initially located, indicating that the photos were moved (see **Figure D.5**). If possible, put a photocopy of the removed photograph with the separation sheet. Even though the photographs will be stored elsewhere, they technically remain part of the letters. They should still be considered part of the file units and series in which the records creator originally filed them. They don't constitute a separate series or subseries.

For further guidance on removing certain types of documents from their original locations for preservation purposes, see Sections N-Q.

9. *What's the difference between a "closed" series or collection and an "open" or "recurring" series or collection?*

A "closed" collection or series has been accessioned and cataloged. There is no expectation that additional materials will be accessioned later for addition to that collection or series. Closed collections and series tend to be those that were created many years ago by individuals or organizations that are no longer producing records. It's possible that supplementary accessions (or "accretions") can be added to closed collections or series. This typically occurs when some historical material is overlooked when the bulk of the collection was first transferred to NPS. When such material is discovered, it may be restored to the existing collection in the form of an accretion. Ordinarily, however, accretions of new material are not added to closed collections.

An "open" or "recurring" collection or series is one where additional accessions are expected routinely. The collections or series are still being created on an ongoing basis. You can keep adding new accessions to these series and collections even after they have been cataloged. All you have to do is add the new material (as a file unit within an existing series, or as a new series within an existing collection). Modify the collection level description in the catalog record to reflect the addition of the new material (for example, the volume and date range could change and the hierarchical structure could change if there is a new series). Contact the Park Museum Management Program in the Washington Office to adjust your Collections Management Report when you make your annual National Catalog submission. (The "new" cataloging will show up under previously Cataloged Part I and Total Cataloged Part III.)

The various categories of park records are the most prevalent type of open collections or series likely to be maintained by NPS museum programs. This is because the same kinds of park records are being produced on an ongoing basis by the parks.

Example: Associated Records are a textbook example of recurring series. A park is likely to accession new project files in archeology, paleontology, biology, or geology on an ongoing basis—perhaps annually, for some parks. Once you have established a collection or a series for project files in a particular discipline, you only have to add the new project files to that existing collection or series and then update the catalog record.

As noted in Sections E and F, only certain types of park records may be accessioned into museum collections. Park records should be disposed of in accordance with NPS-19 and the Federal Records Act. It's permissible for

museum programs to accession resource management records, as defined by NPS-19. Most other park records should either be destroyed or transferred to the National Archives and Records Administration.

10. *How should I arrange an open or recurring series or collection?*

There are two ways of handling additional accessions for an open or recurring collection or series:

- Newly accessioned file units can be added to the end of an existing series if minute interfiling is not required. For example, suppose an existing series consists of reports that are arranged chronologically from 1940 to 1960. The accretion contains the same kind of reports arranged chronologically from 1961 to 1970. The accretion can be added seamlessly to the previously accessioned materials as part of the same series. Adjust the collection level catalog record and the collection and series level archives records to reflect the additional material.
- Newly accessioned file units that can't be added easily to an existing series may be added to the existing collection as a new series. For example, suppose the accretion contains the same kinds of material, but the material is arranged differently. Create a new series record in the ANCS+ Archives Module. Adjust the collection level catalog record and collection level archives record to reflect the existence of a new series.

Note: Accretions to open or recurring collections or series shouldn't be handled as new collections. They shouldn't receive separate catalog records. For example, your resource management records include a series of plant surveys covering the years 1985-1989. You accession additional plant surveys covering the years 1991-1995. Those new plant surveys should be added to the existing series. They shouldn't be cataloged as a new collection.

K. Organization, File Units And Items

1. *What's a "file unit"?*

A "file unit" is the basic means by which individual documents are physically consolidated and arranged. File units are the building blocks of the series (or subseries). A series that doesn't need to be subdivided into subseries (or a subseries that doesn't need to be divided into sub-subseries) is typically a body of records that is made up of one or more file units, arranged in a consistent pattern.

When records creators start accumulating records, they usually do so by setting up file units. The file units hold documents relating to particular projects, or topics, or individuals, or functions. The file unit, therefore, is the component of the series (or sub-series) that contains all of the documents relating to a project, individual, or function, that were filed together.

2. *Is a file unit the same thing as a file folder?*

No. It's important to understand that the file *unit* is not the same thing as a file *folder*. A file unit is a grouping of related documents. A file folder, however, is merely a physical device for holding those documents. There is no limit to the size of a file unit. If a project is especially complicated or protracted, the project file may grow. It may encompass hundreds of pages, held in dozens of file folders. The project file constitutes just one file *unit*,

no matter how many file *folders* it requires.

3. *How are file units arranged?*

File units are arranged in several ways.

<i>If...</i>	<i>Then...</i>
the title on a file unit contains names or words,	the files probably will be arranged alphabetically.
the title of a file unit is a number,	the files probably will be arranged numerically (or by filing code).
the title on a file unit is a year or date,	the files probably will be arranged chronologically.

4. *Should I subdivide file units?*

No. File units should remain intact, even if they contain a mix of documents. For example, suppose a records creator routinely places all of his or her records each month into a single file unit. These may include reports, invoices, correspondence, newspaper clippings, and transcripts of speeches. You would not subdivide this group of material. Each file unit would contain the same sort of thing (that is, everything). The file units could be placed into a consistent arrangement pattern (arranged chronologically by month).

Leaving a file unit intact, however, is not the same thing as leaving everything in one folder. If a single file unit contains many pages, it may be necessary to use several folders to contain all the pages, but doing so does not mean you are creating new file units. Instead, you are just using more than one folder to contain a single file unit. Also, a file unit may contain oversized maps that should be removed and flattened, but doing so does not mean you are creating a new file unit for those maps. The maps are still part of the file unit intellectually, even if they have been separated from the rest of the file unit physically.

Remember: a file unit is not the same thing as a file folder. A file unit would contain all of the documents filed together by the records creator on a particular topic, or project, or individual, regardless of how many documents there might be. The file unit might cover many folders, depending on how many documents it contains.

Note: If a folder is so full that it is bulging, you may divide it into enough folders so that everything fits comfortably. Dividing a file unit into multiple folders is like slicing a pizza. You can cut it into four pieces or six pieces or eight pieces, but it is still a single pizza. You cannot cut it into halves, however, and sell it to customers as two separate pizzas.

5. *What are some types of file units that are not contained in folders?*

Although the majority of documents are placed into file folders, there are other types of file units that don't use file folders, such as:

- *Volumes and Binders.* Some records creators place documents into loose-leaf binders or bind them into volumes. A file unit might constitute all of the documents:

- in the binder
- under one tab in the binder
- in multiple binders

In such cases, you have to look carefully at the titles on binders and tabs to make sure you are able to identify file units properly.

Note: If you are able to remove documents safely from binders or volumes, you should transfer them to regular file folders. See Section O, “Processing and Preservation—Paper-Based Documents,” for information on preservation.

- *Ledgers, Logbooks, and Diaries.* Whether identified by number, date, or name, individual financial ledgers, logbooks, or diaries tend to be regarded as individual file units.
- *Drawers and Divided Drawers.* Oversized maps and charts may be placed into map cases. In such cases, it’s possible that the records creator treated individual drawers as file units. Note the tabs or labels on the drawers and scrutinize the contents closely. This will help you to determine if file units were handled on a drawer-by-drawer basis. Similarly, a records creator may have placed photographs or index cards into rows within filing cabinet drawers. He or she separated the rows with dividers noting name, subject, or some other kind of file unit identifier. All of the photographs or index cards between two dividers might be regarded as file units.
- *Electronic File Folders.* Records creators may keep all of their documents electronically, grouped into electronic files. Retain the electronic arrangement of documents as the file units. In many cases, it may be advisable to print all the documents. Then place them into file units that replicate the electronic arrangement. See Sections N-Q for information on preservation and processing.

6. What’s an “item”?

An “item” is a single document. Most collections are made up of series, and most series are made up of file units. File units are made up of items.

“Item” and “document” are not synonymous with “page” or “sheet.”

An item may only be a one-page note, or it may be a report extending to hundreds of pages. Whether one page or hundreds of pages, it would still be just one item. An item might also be a single magazine, or a photograph, or a reel of audio tape, or even a roll of film.

An item may include attachments. If a letter is received with other documents as enclosures, those enclosures should be regarded as part of the letter. The letter and the enclosures together would constitute a single item.

Remember, archival and manuscript collections should be organized hierarchically, from the general to the specific. The collection level is at the

top of the hierarchy because it's the most general (the collection as a whole). The item is at the bottom of the hierarchy because it's the most specific (individual documents). In between are the intermediate levels of series, subseries, sub-subseries, and file units. These become increasingly specific as you move down the hierarchy.

L. Step-By-Step Arrangement

1. *What's the first step in arranging a collection?*

Step 1: Review the collection in its entirety.

You may do this as part of a formal archival survey, or you may do this informally. In either case, you need to become generally familiar with all parts of the collection. You need to understand the full scope of the collection before you can start arranging the collection. You can't start arranging a multi-box collection simply by opening the first box, taking out a handful of documents, and putting them into some kind of order. You need to have a basic idea of what's in the collection as a whole. You'll then have a basic idea of how everything will fit together. Avoid moving or rearranging anything until you have completed this review. As you conduct our review, be sure to take notes that will help you carry out subsequent phases of the arrangement process.

2. *What sorts of things should I look for in a review?*

Review or survey the collection and conduct additional background research to determine the following:

- What types of records does the collection contain?
- What subjects, functions, and years are covered in the collection? (This shouldn't be an exhaustive and comprehensive list. All you need is a very basic sense of what's in the collection.)
- What is the history of the organization (or the biography of the person) who created the collection?
- Most importantly, can the collection be subdivided into multiple groupings (or series) of records? Does it appear that the person or organization that created the records filed all of the following together:
 - correspondence
 - financial records
 - project files
 - photographs

Note: Not all collections need to be subdivided into series. A collection that consists of one type of material arranged in a consistent fashion doesn't need a series organization. For example, a collection may consist entirely of letters received from various sources. If you can incorporate all of them into a single alphabetical, numerical, or chronological arrangement scheme, then series breakdowns are inappropriate.

3. *What's the second step in arranging a collection?*

Step 2: Identify each of the broad, basic groupings of records within the collection. These are the series.

The series provide the overall organizational structure for the collection. This is critically important because this is the structure you'll have to follow when arranging the collection.

4. *What's the third step in arranging a collection?*

Step 3: Carefully review *each* series you have identified to determine if it needs to be subdivided into subseries.

If so, then identify those subseries, just as you identified the series within the collection as a whole. If there are no series, then skip to Step 7. (Remember that the theory behind breaking series down into subseries is exactly the same as the theory behind breaking collections down into series.)

5. *What's the fourth step in arranging a collection?*

Step 4: If a particular series should be broken down into subseries, then review *each* subseries.

Determine if the subseries need to be divided into sub-subseries. If so, then identify those sub-subseries, just as you identified the series and subseries. If there are no sub-subseries, then proceed to Step 7.

6. *What's the fifth step in arranging a collection?*

Step 5: If a particular subseries should be broken down into sub-subseries, then review *each* sub-subseries.

Determine if the sub-subseries need to be divided into sub-sub-subseries.

7. *When do I stop subdividing a collection?*

Don't get carried away when identifying groupings of records such as series or subseries. Follow the pattern of subdividing until you have identified a body of records that consists only of:

- file units or items, *and*
- the file units or items don't need to be subdivided into groupings

For example, suppose you have properly identified a series of correspondence files. These correspondence files are arranged alphabetically by name of correspondent. Then suppose that there are multiple file units for several of the correspondents. There might be five letters from Mr. Smith, seven letters from Mrs. Bell, and eight letters from Mr. Jones. All of the letters are filed separately. Don't break these out as a subseries of letters for each person. Handle them all as individual file units within the series, arranged according to the series-wide alphabetical arrangement scheme. Be sure to include the date of the letter and the correspondent's name as part of the file unit title. Then arrange the file units for each individual correspondent chronologically. The series would be arranged alphabetically by name of correspondent. The alphabetized file units would be arranged by date.

Note: Such decisions often rely on judgment calls and common sense. A series of correspondence files that includes hundreds of letters from several sources might be appropriately broken out as subseries.

8. *What's the sixth step in arranging a collection?*

Step 6: Identify the arrangement scheme for the file units in the series (or subseries, or sub-subseries, and so forth).

Are these file units arranged chronologically, alphabetically, numerically, or according to some kind of filing code?

9. *What's the seventh step in arranging a collection?*

Step 7: Physically arrange the collection. Make sure all of the:

- items are in their proper file units
- file units are arranged according to the applicable filing scheme
- series, subseries, sub-subseries, sub-sub-subseries are properly grouped

Remember that if a collection is divided into series, then everything in that collection should be contained in one of those series. The collection shouldn't be organized into 10 series plus a few stray documents or file units. If you've identified 10 series for that collection, then every item must be contained in one of those series. You'll have to create new series to accommodate stray documents that don't logically fit within an existing series.

If a series is broken down into subseries, then everything in that series must be contained in one of those subseries. The same principle applies for sub-subseries and for additional levels below that.

If a series or subseries is organized by file unit, then everything should be part of a file unit. If you have a series made up of 100 file units, you cannot also have an individual document included as part of that series. Either locate the file unit where it belongs or create a new file unit for that one document.

10. *How should I arrange an assembled collection?*

An assembled collection is a body of documents selected from multiple sources. The documents have no organic connection to each other. Any order they might have would reflect the activity of the collector, rather than reflecting the activities of the individuals or organizations that created the documents. Therefore, there is no "original order" to an assembled collection and no true hierarchy.

Because an assembled collection is completely artificial, you are free to arrange it in whatever manner seems most efficient. A few suggestions:

Assembled Collection of the Same Kind of Documents

Catalog a collection level record. In the ANCS+ Archives Module, ignore the series, subseries, and file unit levels, and go straight to the item level. Arrange the individual items chronologically, or alphabetically, or any other way that seems to work.

Assembled Collection of Different Types of Documents

Catalog a collection level record. In the ANCS+ Archives Module, create series for each of the different formats, such as letters, diaries, and maps.

Assembled Collection of Small Groups of Documents from Different Sources

Organize the assembled collection into series according to the sources. The U.S.S. Arizona Memorial, for example, includes groups of 5-20 documents that various individuals donated. Most of the documents were collected rather than created by those individuals. The individual groups of documents don't really rise to the level of a true collection. Organizing them each as series within an assembled collection is a way of managing them efficiently, while retaining their provenance.

Assembled Collection Compiled and Arranged by a Private Collector, and Later Donated or Sold to the Park

Catalog as a single collection, retain in the order established by the collector, and provide series, file unit, or item level entries—as appropriate—in the Archives Module.

M. Handling Resource Management Records

1. *What are resource management records?*

Resource management records are park files. They include baseline and other types of information that the park needs to manage its cultural and natural resources effectively. Depending on the park, resource management records might include files on:

- land use
- wildlife management
- construction and maintenance
- research projects in archeology, paleontology, biology, and geology

2. *What are the two acceptable methods for handling resource management records?*

One method is to handle all resource management records for a park as a single collection, covered by a single catalog record and a single catalog number. This collection, of course, will expand as new resource management records are created and accessioned. This means that the catalog record will have to be modified as the collection grows.

The second method is to handle associated records separately from other resource management records. Under this method, all associated records for a specific discipline would constitute an individual collection, with one catalog record and one catalog number. Thus, all records associated with archeological projects would constitute a collection, all records associated with paleontological projects would constitute a collection, and so forth. These collections of discipline-specific project files would also expand over time, necessitating updates to the catalog records.

3. *What commonly used method of handling resource management records should I avoid?*

Many park museum programs have treated files associated with specific projects, studies, or maintenance jobs as individual projects. As a result, parks have many tiny “collections” that in reality are nothing more than file units. This method of handling resource management records is ineffective and fails to meet archival standards.

Handling project files as separate collections is not consistent with standard

archival practice. Archival management is based on provenance (the records creator), not on individual projects. All Resource Management project files are records made or received by the park—regardless of whether they were authored by park staff, regional/center staff, contractors, or outside researchers. Therefore, all resource management records are official records of the park, and that is the basis for defining the collection. Individual project files, rather than constituting individual collections, would be part of a larger series or collection of resource management records.

Example 1: Five different archeological projects took place at a park. One project was initiated by the park and carried out by the park archeologist in order to locate foundations of a historic house that can be highlighted in interpretive programs. Another project was initiated by the regional archeological center and carried out by staff members at the center in order to comply with Section 106 requirements. The third project was carried out by a contractor hired by the park to monitor the impact of new construction on one of the park’s archeological resources. Another two projects were carried out under park permits by local university professors working on separate research projects. Associated records for each five projects were accessioned separately, but they should not be cataloged separately. Even though the five projects were conducted by different archeologists, for different organizations, and for different purposes, **they are all park records relating to one type of activity—archeology.** Instead of each accession being cataloged separately, they should all be cataloged as:

- part of a single series of archeological project files within the park’s collection of resource management records, *or*
- as a single collection of the park’s records associated with archeological projects.

Example 2: A park-owned historic structure is painted in 1960 and again in 1968, 1975, 1982, 1990, and 1995. It is legitimate to keep the documents as resource management records. But these slender files on individual paint jobs down through the years should not be handled and cataloged as separate collections. Instead, they should be handled as simple file units, within a subseries relating to the painting of historic structures, within an overall series relating to construction and maintenance, within a collection of general resource management records.

4. *How is it possible to find individual files if all resource management records or all records associated with the projects in a specific discipline are covered in only one catalog record?*

It is easy to locate files *if you use archival methods instead of curatorial methods.* This means:

- organizing files according to standard, hierarchical archival principles
- entering collection-level information into the catalog record and entering series and subseries descriptions (as appropriate) into the Archives Module, taking special care to explain how the files are arranged in each series or subseries. If more information is needed in order to locate individual files, you may either do file-unit level descriptions or container lists in the Archives Module.

It is never enough simply to provide a general description in the catalog record. Proper archival management requires that series descriptions and other information be entered in the Archives Module.

5. *How should I arrange a collection containing all of a park's resource management records, including the associated records?*

They should be organized into series according to discipline or function, such as:

- Land Records
- Wildlife Management Records
- Construction and Maintenance Records
- Archeology Records
- Paleontology Records
- Biology Records

The file codes in the NPS-19 (Appendix B) may help to identify appropriate ongoing resource management series. The various series, in turn, may be broken down into subseries and sub-subseries. These subdivisions depend on the nature of the records and the way in which they have been filed. Within each series or subseries, be careful to note how the files are arranged—alphabetically? chronologically? numerically?

6. *How should I arrange associated records at the park that are handled as separate collections?*

All files for a particular discipline for a particular park should be handled as a single collection (even if some of the files are held at the park, some at a regional center, or some in non-Federal repositories) because they are all park records, regardless of where they are housed.

A collection of associated records may be organized into series, depending on a variety of factors. **There is no universal template that you can follow when organizing any collection. The way in which the collection is organized depends on the type of material, the nature of the projects, how the documents are filed, and other considerations.**

See the “If-Then” Box for suggestions on how a collection of associated records might be organized. See **Figure D.4** for several examples of how to organize collections of associated records into archival hierarchies.

<i>If...</i>	<i>Then...</i>
you have to determine whether or not to accession Resource Management Records,	consult the NPS-19, Appendix B, to identify which types of Resource Management Records are appropriate for accessioning into the park museum collection, which types should be transferred to the National Archives, and which types should be destroyed.
you have accessioned Resource Management Records into your park museum collection,	handle them as a single collection, with one catalog number, and organize them into series and subseries approximating the various categories in the NPS-19, Appendix B. Carefully describe each series and subseries in the Archives Module, and prepare container lists as desired.
you receive <i>additional</i> accessions of Resource Management Records <i>after</i> you have already cataloged a body of Resource Management Records under one catalog record,	add the new accessions under the existing catalog record. If the new accessions fit under existing series, then simply modify the series descriptions to reflect the new material, and amend the container lists. Otherwise, add new series as necessary. Then update the catalog record to reflect the additional volume, the new date range (if applicable), and the added series (if applicable). Copy the revised catalog record over to the Archives Module. Contact PMMP to adjust your CMR when you make your NCS submissions. (The “new” cataloging will show up under previously Cataloged Part I and total Cataloged Part III.)
there are Associated Records included among your Resource Management Records,	you may handle all the files for a particular discipline (archeology, paleontology, biology, or geology) as a series within the overall collection of Resource Management Records, or you may handle all the files for a particular discipline as a collection unto itself (e.g., Records Associated with Archeological Projects, Records Associated with Biological Projects, etc.)
Associated Records in a particular discipline were originally filed	retain that basic structure by organizing the collection into

<p>according to document type (for example, all the reports, correspondence, and other textual materials together; all the photographs together; all the maps together),</p>	<p>series by type; if the Associated Records for that discipline are being handled as a series within an overall collection of Resource Management Records, then organize the series into subseries by type.</p>
<p>maps, photos, and textual material for a collection or a series of Associated Records originally were all filed together in the same folders,</p>	<p>do not organize the collection into series by type (or the series into subseries by type). Instead, retain the simple file unit arrangement, but remove photos and maps for separate housing. Even though the photos and maps are housed separately, they would not constitute separate series or subseries because technically they will remain part of the file units from which they were removed.</p>
<p>Associated Records for a particular discipline include files relating to projects initiated by the park, by a center, or by private researchers working under permits,</p>	<p>either maintain a single arrangement scheme for all the files, according to the accession number, <i>or</i> organize the collection into series (or subseries) according to who initiated the project: one series for records of projects initiated by the park; one series for records of projects initiated by a center; and one series for records of projects initiated by private researchers.</p>
<p>your park is the lead park for multi-park projects in biology, and therefore receives accessions both for park-specific biological projects and multi-park biological projects,</p>	<p>organize your collection of Associated Records Related to Biological Projects into two series: one for park-specific projects, and one for multi-park projects.</p>
<p>Associated Records for a particular discipline include files for park projects, center projects, and private (permitted) projects, <i>and</i> were originally filed by record type (textual materials, maps, photos, etc.)</p>	<p>first, organize the collection into series according to who initiated the project (one series for the park, one series for the center, and one series for private researchers). Second, organize the series into subseries by record type.</p>

7. *If all project files for a discipline are brought together into a single collection, isn't that like mixing collections or creating an artificial collection?*

No. Most associated records are simply the records of individual projects. Individual project files are not collections.

Archival management is based on the concept of "provenance," which refers to the person or organization that maintained a set of files. Project files in archeology, paleontology, geology, and biology may be authored by different people and organizations (NPS staff, contractors, outside researchers, consulting firms, universities). However, the actual copies that

were submitted to and retained by the park are park records. That is, they are records created or received by the park in the course of conducting official activities. One records creator (the park) plus one type of material (project files in a specific discipline) equals one collection. Therefore, individual project files simply are part of that single collection.

The concept of “non-mixing,” however, still prevails. Just as you should not mix collections, you should not mix project files or file units within collections. The file for each project needs to remain intact and distinct from files for other projects, even as they are contained within a single collection or series.

8. *How should I catalog a collection of associated records?*

Enter collection-level information into the catalog record in the Collections Management Module. Then, copy that information over to the collection-level screen in the Archives Module. Then, enter series-level and subseries-level data into the Archives Module, as appropriate. Within the series or subseries, the associated records should fall into natural groupings of one or more folders that relate to a single research project (and any objects or specimens associated with that project). Each folder or group of folders relating to one project would represent one file unit (or project file). You may arrange these file units within their series or subseries in any scheme that works for your park. One option is to use accession numbers as the organizing principle. The accession number would also serve as the file unit number, and you would be able to arrange the project files by accession number. Provide a file-unit level description for each project, under the appropriate series. Include all the information you will need to locate it—such as name of project, name of project director, subject, dates, location of project. If a project file has multiple folders, you may list the titles of each folder in the container list (which can be found in the Supplemental Information attached to the collection-level screen in the Archives Module). See **Figure D.6** for an example of a finding aid based on this model.

Remember that the physical arrangement should mirror the intellectual arrangement. Project files should follow the same order in the Archives Module as they do on the shelves. Thus, if you identify individual project files by their accession numbers in the Archives Module, then they should be boxed and shelved in the same order. The primary exception to this rule is for project files that must be co-located at another repository so that they can remain with their associated objects (See Items 9 and 11 below).

9. *What if project files are held at different locations—with some at the park, some at a regional archeological center, and some at a partner repository?*

Because all the project files would be records of the park, they should all be described under a single catalog number as part of a single collection **regardless of their storage locations**. If the records relating to a specific project must be loaned or transferred off-site, all you have to do is complete the necessary Outgoing Loan documentation and indicate in the location field of the file unit screen where the file unit is housed. Provenance—not storage location—is what defines a collection.

10. *How should I arrange and catalog new project files that are accessioned after I have finished cataloging a collection of associated records?*

Since the files should be in accession order (or some other equally easy-to-administer arrangement), simply add new accessions to the end of the collection. Then, add a new file unit record in the Archives Module describing the new accession. List folder titles as necessary in the container list. Modify the catalog record to reflect changes in the collection's volume and date range. Make sure these updates also appear in the collection level screen of the Archives Module. At National Catalog submission time, ask the Park Museum Management Program to adjust your Collections Management Report to reflect the new cataloging. New accessions can be added this way indefinitely and in a very short time.

11. *Do these methods for arranging records satisfy the Code of Federal Regulations requirement for keeping archeological objects together with their associated records?*

Yes. The regulation specifies that objects and their associated records be held in the same repository, so that the documentation can be retrieved easily to provide context and background for the objects.

The requirement is met by:

- accessioning both the associated records and the objects into the park's museum collection
- ensuring that the documentation shows the link between the objects and the associated records
- co-locating project files with their associated objects, as necessary

The regulations do not specify that any specific filing schemes be followed, so the park is not required to follow such non-standard archival methods as cataloging each accession as a separate collection. Proper archival methods will not interfere with regulatory requirements and should make it even easier to locate project files and associate them with objects—even if they are housed at off-site repositories. Describing a project file within a single collection of park records will not prevent the park from loaning or co-locating that project file.

12. *Without a unique catalog number, how can associated records be cross-referenced to the objects?*

The file unit description for each project will contain its accession number, which should be the same as the accession number for the objects. Even if the objects and associated records are accessioned under different numbers, those numbers can be cross-referenced in the Associated Accessions field in the file unit screen of the Archives Module.

Project files can be cross-referenced just as easily to catalog records for specific objects. For example, suppose a natural history specimen is collected for one project, cataloged separately, and subsequently used for research in connection with another project. The catalog number for that specimen should be noted in the Summary Note for that project's associated records.

13. *How can I loan individual documents or files if they don't have unique collection numbers?*

Associated records can be tracked with the unique archival collection number, series number, and file unit number in the ANCS+ Archives Module. A series, subseries, or file unit remains in the same place in a collection's archival hierarchy, even if the records are on loan. You can also create an individual catalog record in the Collection Management Module for a document or file unit that you send out on loan, and cite the catalog number in the Outgoing Loan Agreement. When the loaned document is returned, you return it to its proper place in the collection's

hierarchy, and change the status in the catalog record to “Incorporated into Larger Archival Collection.”

N. Processing And Preservation

1. *When should I process an archival or manuscript collection?*

It often makes sense to process a collection at the same time you’re arranging it. This may be the only time you will need to handle virtually every document in the collection individually. It’s efficient to use the opportunity to:

- refolder, rebox, and label the collection
- cull extraneous material
- take basic steps to protect damaged or fragile documents

Processing a collection in this way can serve as the first line of defense in preserving a collection.

2. *What supplies and equipment will I need to process an archival or manuscript collection?*

Examples of the supplies and equipment you may need to process a collection appear below. You probably won’t need all of these supplies for every project, so you don’t need to keep stockpiles of everything. It is probably advisable, though, to have supplies of boxes, folders, polyester sleeves, spacer boards, white gloves, and other most commonly used supplies readily available.

- acid-free document storage boxes (flip-top archives boxes) in letter-size and legal-size
- acid-free flat storage, newspaper storage, and drop-front storage boxes in various oversized dimensions, as appropriate
- acid-free records storage boxes (also called “records center cartons”) in one-cubic-foot size
- acid-free photographic print and negative boxes
- acid-free slide storage boxes and slide storage cases (for holding the boxes)
- acid-free file folders in letter-size, legal-size, and various oversized dimensions, as required
- buffered photographic print and negative envelopes and sleeves (for black and white images)
- unbuffered photographic print and negative envelopes and sleeves (for color images) **Note:** Recent research suggests that high quality buffered paper may be better for color images than unbuffered.
- unbuffered, four-flap enclosures (for glass plate negatives)
- polypropylene sheets and sleeves for photographic prints, negatives

and slides

- archival-quality polyester sleeves (Mylar D) in legal-sized and letter-sized
- acid-free spacer boards
- white, acid-free, high tack neutral pH acrylic adhesive box labels
- soft lead pencils
- bond paper, interleaving sheets, and rolls of archival-quality interleaving and wrapping paper
- soft, unbleached cotton tying tape
- plastic or stainless steel paper clips
- micro-spatulas
- flat-blade staple removers (not standard office supply staple removers, which can damage documents)
- pH testing pens
- cotton gloves

In addition, refer to the *Museum Handbook*, Part I, the *Conserve O Gram* series, and the *Tools of the Trade*. They contain information on storage equipment, such as cabinets and shelving.

Depending on the archival materials already available to you, you may not need all of the supplies and equipment listed above. You may need additional items. For example, there are specialized boxes, sleeves, envelopes, and wrappings for microfilm, microfiche, compact disks, videotapes, motion picture film, and the diverse formats of sound recordings.

For additional materials you may need, consult the NPS *Tools of the Trade* or any of the various commercial archival supply catalogs.

3. *What are textual and non-textual materials?*

Textual materials are traditional, paper-based documents, such as letters, reports, notes, clippings, telegrams, and memorandums.

Non-textual materials are records in a variety of specialized formats. These include:

- cartographic records (maps)
- architectural/engineering drawings
- photographs (prints and negatives)
- motion picture film

- videotapes
- audio recordings (reel-to-reel tapes, tape cassettes, compact disks, wax disks, wax cylinders, and wire recordings)
- microforms, including roll film, sheet fiche, and aperture cards
- computer punch cards
- electronic records in all storage media (floppy disks, compact disks, magnetic tape, and even hard drives)

4. *Should I process textual and non-textual records differently?*

Yes. Process textual and non-textual records differently because specialized records require specialized handling. Records in different formats shouldn't be kept together in the same folders or the same boxes because they can damage each other.

5. *What should be done if a collection contains documents that are folded?*

Unfold them. Fold lines can cause damage to both standard-sized and oversized materials. See Section P for information on oversized materials.

For example, it's not unusual for letters to be filed as they were received folded into thirds. Unfold them and file them flat.

6. *How should I handle paper records that are acidic?*

<i>If...</i>	<i>Then...</i>
an acidic document has intrinsic value,	place it in a protective sleeve in order to keep it from damaging other documents. Also place a sheet of alkaline buffered paper in the sleeve, to keep the document from damaging itself with its own acidity.
acidic documents (such as telegrams and newspaper clippings) don't have intrinsic value,	replace them with copies made on acid-free paper and destroy the originals.
If you are in doubt about an acidic document's intrinsic value,	Don't throw it out; retain the document, but isolate it to prevent damage to other materials.

7. *How should I handle paper records that are fragile?*

<i>If...</i>	<i>Then...</i>
records are fragile but stable (such as letters typed on onionskin paper),	place them in Protective sleeves.

records are fragile and unstable (such as “Thermofax” copies, which become illegible over time and become so brittle that they can break into pieces),	copy them onto acid-free paper, and destroy the originals.
--	--

8. *How should I handle paper records that are damaged?*

<i>If...</i>	<i>Then...</i>
documents are moderately damaged (slight tears, holes),	place them in protective sleeves (avoid attempting to repair them yourself with adhesives).
documents are severely damaged (mold, burn marks, major tearing or shredding),	consult with a professional paper conservator to determine what treatment is necessary.

9. *When should I make “preservation copies”?*

Preservation copies are photocopies, microform copies, or digital copies of documents. They are produced so that researchers don’t have to handle the originals. Having preservation copies helps prevent theft and damage to collections that can occur from overuse.

Note: Preservation copies are different from “surrogate” copies, which literally replace the originals.

It never hurts to have a set of preservation copies for any collection. However, the cost of making them is so high that preservation copying should be done on a very selective basis. Only those collections that are the most important and receive the heaviest use should be considered for preservation copying.

<i>Light-sensitive items, such as albumen prints, should not be photocopied. For further guidance on preservation copying, see Conserve-O-Grams no. 19/4, 19/10, and 19/11.</i>

10. *May I cull materials during processing?*

Yes. Materials ordinarily are identified for disposal during the appraisal process (see Section E, “Appraisal”). However, duplicates and extraneous material may be identified during the processing phase. Those materials may be culled from the collection. Consider the materials to have been accessioned in error. Thoroughly document the removal of the materials and place the documentation in the accession folder. This action is not a deaccession. Don’t follow the standard deaccessioning procedures.

It’s not unusual for a collection to contain multiple copies of the same document. Unless these duplicates have some kind of intrinsic value, it’s permissible to keep just two or three copies. Dispose of the rest.

Follow the disposal procedures for permanent park records. Consult with the park’s administrative officer to see how the park handles the disposal of such records. Remember, however, that culling is an option – it is not mandatory.

Also, be cautious about culling materials from pre-20th century collections. It is all right to cull recent photocopies of documents that have found their way into the collection—but rare handwritten (“fair”) copies or “press” copies dating from the same time period as the documents they duplicate might be worth keeping.

Culling collections during processing is not a substitute for the adequate appraisal of records.

11. *What are some examples of the types of materials that can be culled?*

Types of materials that can be culled include:

- blank sheets of stationery
- inconsequential notes
- unannotated slips of paper used long ago as bookmarks within file folders
- empty and unmarked envelopes
- empty binders
- general publications with no associational value
- documents with privacy information that contributes no value to the collection

Note: It is conceivable that material culled from archival collections may have artifactual value. A ream of blank stationery that got filed with an archival collection may not have any archival value and should be culled. However, depending on its age, if it has a particularly unusual or interesting letterhead, it may have artifactual value. In that case, it may be appropriate to retain one or two sheets in the collection and recatalog the remainder as a non-archival history object.

O. Processing And Preservation—Paper-Based Documents

1. *How should I refolder and rebox paper-based documents?*

Unless a collection is accessioned in pristine condition, it’s usually advisable to:

- transfer documents from their original file folders
- place them in acid-free file folders
- house the files in acid-free archives boxes
- remove oversized and non-textual records (see Section O)
- take steps to preserve any damaged or fragile documents that you encounter (see Section N)

Don't number the documents. Don't write on the documents for any reason.

2. *What size folders or boxes should I use?* Use either letter-sized or legal-sized acid-free folders and boxes, depending on the nature of the collection. Collections often contain a mix of letter-sized and legal-sized documents. You should avoid folding legal-sized documents to make them fit into letter-sized folders and boxes. For this reason, legal-sized folders and boxes are preferred—even if a collection is composed predominantly of letter-sized documents. The snug fit of a letter-sized box can cause damage to the documents. Letter-sized storage materials, however, are less expensive than legal-sized materials.
3. *Should I remove paper clips, staples, and other fasteners?* If at all possible, try to remove metal paper clips, binder clips, pins, brads, Acco fasteners, staples, and rubber bands from documents as you process collections—especially if they are rusty or doing obvious damage.
- Take great care when removing staples. To avoid damaging the document, don't rip a staple out from the front by using a standard office staple remover. Instead, turn the document over. Use a flat-bladed archival staple remover. Fold back the ends of the staple so they are sticking straight up. Then turn the document back over. Slide the blade under the staple and gently slide it out of the document.
4. *Should I remove documents from binders?* Yes. If it's practical to do so, remove documents from three-ring binders, and place them in file folders. Examine the binders carefully to determine if:
- the title on the binder as a whole represents the file unit title, *or*
 - various tabs in the binder represent file units, *or*
 - the binder is actually part of a larger file unit
5. *How should I handle multi-page documents?* If multi-page documents are contained in a folder with other documents, they may need to be fastened in some way. If they aren't paginated, they can easily get mixed up with other documents in the folder. You can fold a sheet of bond paper in half (like a mini-file folder) and slip the document in that, or use interleaving sheets to separate documents. Alternatively, you may fold a very small piece of bond paper over one corner of the multi-page document as protection. Then place a stainless steel paper clip over top of the bond paper. You should only do this, however, if the document is not so thick that a clip would create impressions in the document.
6. *Can I break materials into multiple folders if the original file folder is too full?* Yes. If the original file folder is overstuffed, don't transfer the entire contents to a single new folder. Instead, break up the contents into multiple folders that don't exceed 1 inch in thickness. As explained in Section K, this is still just one file unit. It doesn't matter how many file folders are needed to contain the materials. For example, a file unit entitled "Correspondence, July 1928" has to be broken up among three folders. It remains a single file unit even though it is contained in three folders. The titles on the folders should indicate that the file unit is foldered in sequence:
- "Correspondence, July 1928 (Folder 1 of 3)"

- “Correspondence, July 1928 (Folder 2 of 3)”
- “Correspondence, July 1928 (Folder 3 of 3)”

7. *How should I label file folders?*

Write the folder title on the upper flap of the folder, using a soft lead pencil. Titles should contain the following information:

- catalog number (from ANCS+ Collection Management Module catalog record) or local collection number (from ANCS+ Archives Module entry)
- collection title
- series title (if applicable)
- subseries title (if applicable)
- file unit title (if the file units are arranged under an alpha-numeric or other type of code, then that code designation is the file unit title; if the file unit title is a personal name, then put the last name first)
- the sequence of the folders (Folder 1 of 3, Folder 2 of 3) if the file unit is broken down into two or more file folders
- a consecutive number (acceptable but not necessary)

File units that are arranged properly, according to a clear filing scheme (alphabetical, chronological), don’t require consecutive numbering. The number is superfluous. Moreover, the number of file folders is liable to change. For example, documents in a particular folder may become brittle and worn with time and use. It may be necessary to insert them into protective polyester sleeves. These will expand folders and may make it necessary to divide file units into multiple folders. This, in turn, would necessitate re-numbering all subsequent folders. Collection titles, series title, and file unit titles are permanent and immutable. However, the number of file folders can change for a variety of practical reasons. Thus, numbering all folders as a matter of routine can be an unnecessary exercise.

It’s permissible to abbreviate titles, if that is necessary to fit all recommended information onto the folder label. The George Washington Carver Papers, for example, could be abbreviated as the “Carver Papers.” This abbreviation is appropriate only in the pencil titles on the folders themselves. Enter only full, official titles into ANCS+.

8. *Should I copy everything written on the original folder?*

Not necessarily. Enter only the information that pertains to the actual title of the file unit. File folders often have little personal notes, names, telephone numbers, and other jottings. These have nothing to do with the title of the file unit or the content of the folder. Don’t attempt to copy or preserve such extraneous information.

Notes may appear on the folder that seem to be connected with the content of the file unit. These would be like marginalia, only on the folder as opposed to the margins of the documents themselves. You may copy or save the part of the folder containing that writing. If you save a portion of

an acidic folder for this reason, place it in a protective Mylar sleeve. Keep it as part of the file unit.

9. *How many file folders should I place in a box?*

Only put the number of folders in a box that will sit vertically, comfortably resting on the bottom fold. There should be enough folders in the box to keep the folders from sagging, but not so many that the box will bulge.

If you don't have enough folders to fill a box completely, insert a spacer board to keep the folders upright. (A spacer board is a length of acid-free corrugated board. It can be folded to the desired size and inserted in a box to create a false back, against which folders can rest.) Spacer boards—also called “document support spacers”—are available through archival supply catalogs.

10. *May I mix files from different collections in the same archives box?*

No. Even if you don't have enough files from a particular collection to fill an archives box, don't mix collections. Never box different collections together.

If you're working with a very small collection, you may not have enough folders to fill a box. You may also have boxed all but the last two or three folders of a larger collection. In these cases, you have two options:

- Use a spacer board, as described above.
- Use a smaller box. Archives boxes with a depth of only 2.5 inches are available through archival supply catalogs.

11. *How should I label the boxes?*

As arrangement and processing are underway, you may label boxes temporarily. Write the:

- catalog or local collection number
- series title
- box number

Write lightly in pencil on the part of the box that eventually will be covered by the permanent label. For flip-top archives boxes, this would be on the narrow side that would be shelved facing out. This is the side where the top will flip from left to right. The label itself should be on the bottom half of the box. Place it beneath the flip top but above the finger hole or pull string. For records center cartons, the label should be in the center of the side that faces out when shelved.

After processing has been completed, go back and put permanent labels on all the boxes. Print or type the labels onto archival quality, self-adhesive labels. Include the following information:

- park name
- catalog number or local collection number
- collection title
- series, subseries, sub-subseries, sub-sub-subseries title, as appropriate

- title of first file unit in the box
- title of last file unit in the box
- box number

Note: Number boxes consecutively from the first box to the last box in the collection as a whole, regardless of series. Number each collection separately.

12. *Should I keep the original folders, binders, and boxes?*

No. After a collection has been refoldered and reboxed, throw them away or recycle them. They have no archival value.

The only exception would be for boxes, binders, or folders that contain information, such as notes that the records creator made.

<i>If...</i>	<i>Then...</i>
the notes have intrinsic value because they were written by a notable historic figure,	keep the relevant portion of the folder, binder, or box as part of the collection. It may be necessary to enclose that portion of the folder, binder, or box in a polyster sleeve.
the notes have informational or evidential value but no intrinsic value,	copy the relevant portion onto acid-free bond paper, keep the copy, and discard the original.

P. Processing And Preservation — Oversized Materials

1. *How should I handle oversized materials?*

Legal-sized or letter-sized textual records frequently will contain oversized documents. These typically have been folded to fit into a legal-sized or letter-sized folder or rolled and placed in tubes. Examples include:

- maps
- charts
- diplomas
- certificates
- posters
- newspapers
- bound volumes

- petitions
- architectural drawings
- engineering drawings

Ideally, oversized documents should be:

- removed from smaller folders
- flattened (unfolded); if folded documents are too brittle to be flattened safely, consult with a paper conservator
- placed in appropriate-sized folders and storage boxes

If they're so large that no folders or boxes can accommodate them, place them in map drawers. Separate them with interleaving sheets. (Because interleaving sheets can add weight and bulk, be careful not to overload drawers.) You may also place them onto acid-free rolling tubes.

Be sure to separate oversized materials by type. Store oversized blueprints separately, for example, from newspapers or oversized photographs.

2. *How do I show the removal of oversized materials?*

Whenever you remove an oversized item, you must replace it with a "separation sheet." See **Figure D.5**. The separation sheet should show the name of the document. For documents that don't have a formal title, give a short but meaningful description, such as "Map of Gettysburg, 1863," "Architectural Drawing, Park Visitor Center, 1968." The separation sheet should also show the title of the collection. As applicable, include the title of the series, subseries, and file unit.

Place the separation sheet in the exact location where the oversized item initially belonged. In addition, keep a copy of the separation sheet with the oversized document in its new location. It's necessary to have separation sheets in both places. Researchers going through the files will then know that a document has been removed. The original location will also be clear to anyone looking at the oversized document.

3. *Why do oversized documents have to be removed?*

Oversized documents often don't fit into legal-sized or letter-sized folders and boxes. Attempting to do so usually means folding the documents one or more times. Folding, unfolding, and refolding documents can cause damage. Documents become brittle and weak along fold lines and can easily break apart. Oversized documents can also become frayed and torn if edges stick out from file folders. Therefore, removal and flattening of oversized documents is a basic preservation action.

4. *How should I file oversized items after they're removed from their original locations?*

Typically, place oversized documents at the end of the collection from which they were pulled. Organize them by type—textual documents (documents on plain paper), architectural drawings, posters, bound volumes, and so forth. Arrange them in the same order as the collection as a whole.

For example, two oversized documents were removed from file A in Series I of a collection. Another oversized document was removed from file D of

that same series and another from file W of that same series. Three oversized documents were removed from Series II. The documents from Series I, file A would be filed first. The documents from Series I, file D and Series I, file W would be filed next. The documents from Series II would be filed last.

5. *Should I handle a group of oversized materials at the end of a collection as a series (or subseries or sub-subseries)?*

No. A group of oversized documents that has been separated from the original file doesn't constitute a series. The documents have no separate place in the collection's hierarchy. They are *housed* separately, but only as a practical measure, to help preserve them. Technically, they remain part of the file unit and series from which they came.

A group of oversized documents separated from the original files shouldn't be identified in the hierarchy. The documents shouldn't be regarded as a series or subseries. They shouldn't be described as any kind of unit within the ANCS+ Archives Module.

Such documents would be described specifically in the Archives Module only if the entire collection were being described down to the item level. This is almost never done. Even then, the item level description for each oversized document would be subordinate to its original file unit and series.

For further information on how to catalog and describe archival collections, see Sections R and S.

Q. Processing And Preservation — Photographs

When handling photographic materials of any type, it's important to wear white cotton gloves. The gloves protect the images from dirt and skin oils.

1. *How should I handle photographs that are part of standard textual files?*

Inks and papers in standard textual file units can damage photographs. Emulsions and chemicals from photographs can harm textual documents. If you encounter photographs in folders containing textual records, you should either remove the photographs (in the same manner as you would remove oversized documents) and replace them with separation sheets, or place them in protective sleeves and leave them in their original locations.

If you separate photos from the textual records, you should organize them by type (prints, negatives, slides) and arrange them in the same order in which they appeared in their original textual locations. When a photograph is removed from a textual file, replace it with a separation sheet (see **Figure D.5**). If possible, place a photocopy of the separated image with the separation sheet. Also be sure to keep a copy of the separation sheet with the photograph at its new location.

2. *What if photographs are attached to pages in a textual document?*

Unless they are doing damage or being damaged, leave them where they are. Place interleaving sheets between the pages. If you should note any damage being caused by the photographs, by the pages to which they are attached, or by the adhesives, you should consult with a conservator. (Also see Item 6, below, concerning procedures for handling photograph albums.)

3. *Should I add photographs that were separated from textual records to a series consisting exclusively of photographs?*

No. Some collections have series consisting exclusively of photographs. Ordinarily, this is because the person or organization that created the collection established a separate series of photos. For example, the records creator may have created albums of sequentially numbered images. Or the creator may have set up a working file of photos arranged by subject. That series should not be disturbed by adding photos that weren't there before.

Photographs located in textual files, for example, wouldn't have been part of that photo series. An individual photo may have been attached to an incoming letter and kept with that letter in a correspondence file. The photo is part of that letter. As such, it's part of the file unit and part of the series to which the letter belongs. Just because it's a photograph, doesn't mean it should be moved to a collection of photos that the records creator set up.

The reason for this goes back to the principle of original order. Separating a photograph or an oversized document from its original file unit doesn't alter the original file arrangement or series organization. Photographs and oversized documents are still part of their original file units and series in a technical or intellectual sense. Housing them separately is for preservation purposes only. It doesn't affect the archival hierarchy in any way.

4. *How should I house photographs?*

Separate photographic materials by type (prints, negatives, slides). Place them in protective envelopes or sleeves and store them in archival-quality photograph boxes. Slide storage boxes are small and narrow and should be placed into slide storage cases. The cases hold up to six boxes.

Place images in uncoated, inert, polyester (Mylar D) sleeves. The sleeves are expensive, but they allow you to view images without actually handling them.

You may also use paper envelopes and sleeves. Images have to be removed to be seen, but they are less expensive than polyester sleeves. They also do a better job of preventing the buildup of moisture and gasses because they are porous. Use unbuffered papers for color images. Use buffered papers for black-and-white images.

Store images less than 10" x 12" on edge. Don't stuff them so tightly into boxes that the boxes bulge. Don't store them so loosely that the photographs sag. Store oversized, fragile, or damaged images flat.

Place glass plate negatives into seamless, four-flap enclosures. Store them upright in document storage boxes lined on the bottom with Ethafoam. Nitrate negatives should be placed in cold storage. If possible, replace nitrate negatives with safety-base surrogates. Unless they have intrinsic value, destroy them after replacement—*especially if they are in poor and potentially unstable condition*. They should be handled as hazardous waste.

When nitrate negatives are replaced, the surrogate becomes the new object. You can destroy the original without having to deaccession it unless it has intrinsic value.

5. *Should I place loose photographs in albums?*

No. Envelopes and boxes are the appropriate storage media for prints, negatives, and slides.

6. *How should I process photographic albums?*

Ordinarily, photograph albums and scrapbooks are left intact. Trying to remove photographs that have been glued onto album leaves may damage the photographs. The albums may also have intrinsic value. This is especially true if they were compiled by a noted individual. The leaves may also contain captions, notes, and marginalia. Many of these old albums are quite stable; if they are, leave them intact and monitor for deterioration.

Photographs that were mounted in albums made of acidic paper may be in danger of being damaged. Consider the following steps:

- Make photocopies of each page of the album on acid-free paper.
- Make duplicate negatives and new prints of each of the photographs.
- Make digital scans of each of the photographs.
- Remove photographs from albums if this can be done without damaging the photographs. It may be necessary to consult with a professional photographic conservator to determine if the photographs can be removed safely.

R. Cataloging

1. *What's "cataloging"?*

Cataloging refers to the creation of a catalog record for archival collections. The catalog record should focus on the collection as a whole. Enter the catalog record in the ANCS+ Collection Management Module. The catalog record contains both collections management and basic descriptive data about the collection. It also serves as the principal accountability record for the collection.

Don't attempt to catalog a collection before it's arranged. Arrangement establishes a collection's hierarchy, and the cataloging of a collection is based on that hierarchy.

See Sections H and I for information about arrangement and hierarchical structure.

Note: Refer to Chapter 2, Section II of the *ANCS+ User Manual* for instructions on completing the fields on the collection level catalog record.

2. *Should there be a catalog record for each document in a collection?*

No. Don't catalog individual documents or "items." There should be only one catalog record for the collection as a whole. You may describe individual items in the Archives Module, but this is seldom necessary. In fact, avoid item level description if at all possible.

3. *What if a document is pulled from a collection to go on loan?*

To loan a document to another institution, the document will need to have a unique identification number. You can assign a unique identification number to a document for purposes of loaning it. Create an individual catalog record for that document, or create an item-level entry for that document in the Archives Module. Item level cataloging or description in this situation is done only to facilitate the loan process. It doesn't change the status of the document in any way. The document is still part of a larger collection, not a stand-alone museum object. Upon being returned at the end of the loan period, file it in its original location.

4. *Should there be a catalog record for each file unit in a collection?* No. Don't catalog individual file units. There should be only one catalog record for the collection as a whole. You may describe individual file units in the Archives Module, but this is seldom necessary. As a time-saving alternative to full descriptions on each file unit, develop "folder title lists" or "container lists" in the Archives Module (see Section T).

5. *Should there be a catalog record for each series or subseries in a collection?* No. There should be only one catalog record for the collection as a whole. There's only one catalog record regardless of the size of the collection or the number of series it contains.

Fully describe all series, subseries, sub-subseries, and sub-sub-subseries in the Archives Module (see Section S).

6. *What's the connection between archival hierarchies and archival cataloging/description?* As explained in Sections H and I of this appendix, archival and manuscript collections are arranged *hierarchically*. They should be cataloged and described in the same fashion.

Hierarchical *arrangement* means that a collection is organized into subordinate groups. These groups are in turn broken out into subordinate groups, which in turn are broken out into individual items. The "top" of the hierarchy is the most general level: the collection as a whole. The "bottom" of the hierarchy is the most specific level: each individual document. In between the top level of the hierarchy and the bottom level may be groups of documents called "series." These are somewhat more specific than the full collection, but are still fairly general. Just as a collection may be organized into series, individual series may be organized into subseries. These are more specific than series, but more general than file units or individual documents. Subseries may be made up of individual file units, which are very specific. The file units are made up of individual documents or items, which are the most specific parts of the hierarchy.

Hierarchical *description* means that collections should be cataloged and described hierarchically, just as they are arranged. **Figure D.3a** shows a sample hierarchy for the Records of the XYZ Corporation. Description begins with a catalog record (in the Collection Management Module) for the records of the XYZ Corporation as a whole. Descriptions of the series and subseries can then be completed in the Archives Module. In other words, *the cataloging and descriptions proceed from the general to the specific, following the arrangement scheme*. The hierarchy serves as a sort of outline or table of contents.

You should describe each element in the hierarchy above the file unit level. You may draw up lists for file units. However, descriptions on individual file units and items is optional (and usually discouraged).

7. *What is the process for cataloging an archival collection?* Follow these steps to catalog an archival collection:

- Enter a brief description of the collection as a whole into the ANCS+ Collections Management Module. This is the only catalog record for the collection that you should enter into the Collections Management Module.

- Copy your entry in the ANCS+ Collections Management Module over to the collection level screen of the Archives Module.
- Enter descriptions of each series in the collection, using as many series level screens as necessary. Each series gets its own screen.
- Enter descriptions of each subseries (or sub-subseries), if there are any. Each subseries gets its own screen.
- If you absolutely have to do it, enter descriptions for each file unit in the File Unit Level. Each file unit gets its own screen.
- If you absolutely have to do it, enter descriptions for each document in the Item Level.

Usually it's okay to stop at the series level. You need to describe most collections only at the collection and series/subseries levels. Going beyond that usually involves a lot of work and little gain.

8. *Do I have to enter the information from the top down?*

Yes. You have to go from the general to the specific. That is, you have to do your Collection Level description first. This is followed by Series Level descriptions, followed by Subseries Level descriptions, followed by File Unit descriptions (if necessary), and so forth.

Note: You can always go back and revise Collection or Series Level entries even after you have moved on to the Subseries or File Unit Levels. In other words, you have to *start* at the top and work your way down, but you can always go back up to the top to make revisions.

9. *Why must I enter information from the top down?*

Because the system is hierarchical, you have to enter information hierarchically. You enter the Collection Level description first, the Series Level descriptions second, and so forth. Your entries will be numbered so that all entries from the Collection Level down to the Item Level are linked. You have to do the Collection Level first because it will be the parent screen for all of the Series Level descriptions. You have to do your Series Level descriptions before you do subseries descriptions. This is because the Series Level screens are the parents for the Subseries Level screens. The same principle applies as you move down the hierarchy to the File Unit and Item Levels.

S. Description

1. *What's description?*

Description refers to written summaries of a collection and its series, subseries, and other components. You enter these descriptions in the ANCS+ Archives Module. The collection level description also appears in the catalog record, but the descriptions of series, subseries, and other components appear only in the Archives Module.

2. *How do I write a Collection Level description?*

To write a Collection Level description, you need to focus on three critically important fields:

- organization/arrangement
- scope

- history

Note: Refer to Appendix F of the *ANCS+ User Manual* for instructions on completing the other fields on the Collection Level record.

Organization/Arrangement (Collection Level)

List the series that make up the collection. Some small collections consist of file units that aren't organized into series. Indicate whether the file units are arranged alphabetically, numerically, chronologically, or according to some other filing scheme.

Scope (Collection Level)

First, list examples of the types of documents that appear most frequently in the collection. Examples include correspondence, reports, maps, architectural drawings, engineering drawings, photographs, newspaper clippings, and sound recordings. Second, provide a one paragraph overview of the collection. Cite the sorts of activities that are documented and examples of specific topics and highlights.

History (Collection Level)

For organizations, provide a brief history of the organization that created the records. For personal papers, provide a biography of the person that created the records. For example, provide a brief biography of Thomas Edison for a collection of Thomas Edison's personal papers. Provide a brief corporate history of the Thomas Edison Company for a collection of the company's records. Ordinarily, the histories or biographies should be no more than one to four paragraphs. In addition, you may want to include a time-line of dates and events pertaining to the records creator—perhaps as an appendix—but this is optional.

3. *How do I write a Series Level description?*

Follow the same basic procedure used for writing a Collection Level description. Treat each series as if it were a mini-collection (with some slight variations). Focus on three critically important fields:

- organization/arrangement
- scope
- history

Note: Refer to Appendix F of the *ANCS+ User Manual* for instructions on completing the other fields on the Series Level record.

Organization/Arrangement (Series Level)

List the subseries that make up the series. Some series consist of file units that aren't organized into subseries. Indicate whether the file units are arranged alphabetically, numerically, chronologically, or according to some other filing scheme.

Scope (Series Level)

First, list examples of the types of documents that appear most frequently in the series. Examples include correspondence, reports, maps, architectural drawings, photographs, newspaper clippings, and sound recordings. Second, provide a one paragraph overview of the series. Cite the sorts of activities that are documented and examples of specific topics and highlights.

History (Series Level)

You only need to complete the history field in the Series Level screen under certain circumstances. Provide historical information if series are based on specific functional units or events.

For example, suppose the records of a corporation are broken out by series for the various divisions of that company. There's a series for the Research Division, a series for the Manufacturing Division, and so forth. In such cases, it's appropriate to provide a one or two paragraph history of that division.

Another example would be the personal papers of an individual. These could contain series based on specific events or eras in that individual's life. There could be a series of papers on the person's military service, or exploration of the South Pole. Then it's appropriate to provide a paragraph detailing those phases of that person's life.

Don't provide historical information if the series are based simply on the types of documents. A series of correspondence, a series of reports, or a series of photographs doesn't require a history.

Remember: You must use unique titles. No collections among your holdings should have the same title. Within a given collection, no two series should have the same title. Within a given series, no two subseries should have the same title. See Section I, Question 4 for further information. For further information on standards, see the Society of American Archivists' publication Describing Archives: A Content Standard (DACs).

4. *Should I enter descriptions in the Archives Module for all series, subseries, sub-subseries, and sub-sub-subseries in a particular collection's hierarchy?*

Yes. You must individually describe, in the Archives Module, every series, subseries, sub-subseries, and sub-sub-subseries identified in a collection's hierarchy.

For the Subseries, Sub-Subseries, and Sub-Sub-Subseries Levels, follow the same descriptive procedures as for the Series Level.

5. *How do I write a File Unit Level description?*

Complete the basic fields (title of file unit, file unit number). The only other information needed is a one-or-two line overview of the content of the documents contained in the file unit.

Note: Refer to Appendix F of the *ANCS+ User Manual* for instructions on completing the other fields on the File Unit Level record.

6. *Are File Unit Level descriptions required?*

No. File unit description may be done at the discretion of the individual curator or archivist, but most of the time it's unnecessary to provide full descriptions of each file unit. Researchers should be able to find the files

they need if:

- a series (or subseries) is well described, *and*
- the file units are clearly arranged

It's extremely inefficient to describe each file unit. For all but the smallest collections, it involves an enormous amount of time-consuming, labor-intensive effort. This effort only produces minutely detailed descriptions that provide little added value.

Instead of describing each file unit, prepare folder title lists or container lists (see Section T). These are a much more efficient alternative to full file unit description.

7. *Are there situations where file unit description is recommended?*

Yes. Associated records include project files in such fields as archeology, paleontology, geology, and biology. The records for each project should be treated as a single file unit, regardless of the number of folders it might contain. File unit descriptions for each of these projects may note the title of the project, the subject or purpose of the project, the location where the project took place, the project dates, the principal investigators, etc. It should also note the accession number (which will link the file unit to any associated objects) and the storage location (if the file unit is co-located with the objects at an off-site repository). For further information, see Section M, "Handling Resource Management Records." For an example of a finding aid describing archeological records down to the file unit level, see **Figure D.6**.

8. *How do I write an Item Level description?*

An "item" is an individual document (a letter, report, photograph, architectural drawing, memorandum, etc.) regardless of the number of pages. Complete the basic fields (title of document, item number). The only other information needed is a one or two line overview of the document's content. For example, list the subjects covered in the document.

Note: Refer to Appendix F of the *ANCS+ User Manual* for instructions on completing the other fields on the Item Level record.

If a document doesn't have a formal title, enter a brief, functional title. A letter "title" should include the names of the sender and recipient, plus the date. Example: "Jones to Smith, October 1, 1908."

9. *Is Item Level description required?*

No. In most cases, it's unnecessary. Like File Unit Level description, Item Level description is time-consuming and labor-intensive. It's always an option, but you should choose it carefully. Having a finding aid that can direct a researcher to the proper file unit (or group of file units) may be sufficient.

10. *Is it more appropriate to do Item Level description of certain types of documents than others?*

Yes. Photographs, maps, and architectural drawings typically are more appropriate for Item Level description than regular textual materials. However, Item Level description is still optional. Only do Item Level description for photographs, maps, and architectural drawings when there's a real need for it.

If you choose to describe such materials to the Item Level, be succinct. Enter a short sentence fragment, citing only the most essential elements.

Then move on to the next image.

For example, “Franklin Roosevelt and Eleanor Roosevelt sitting on a mule,” is an adequate photo description. Include the date (if known) and the photographer (if important). You don’t need to describe what they are wearing, which way the mule is facing, and what the background scenery is like.

Note: If you do Item Level description of photographic prints, it’s unnecessary to do Item Level descriptions of the associated negatives (provided there is some way of connecting the prints to the negatives).

Generally, Item Level description is appropriate only for collections of the greatest historical significance. Very few collections in NPS custody rise to that level. The best candidates for item level description would be unusually rare or valuable documents—such as letters written by George Washington..

11. *Can Item Level description help preserve collections by reducing the need to search through the files?*

Not necessarily. There are two reasons why Item Level description isn’t a good strategy for preserving collections.

- “Heavy use” is a subjective term, but there are probably very few collections in NPS custody that are used so much that Item Level description would reduce the handling of individual documents in a meaningful way. Therefore, providing Item Level description for the purpose of reducing the need to open boxes and physically retrieve documents may not be worth the effort. The costs to reduce a collection’s use from 30 times a year to 25 times a year would vastly outweigh the benefits.
- Even when collections have been described to the Item Level, they still have to be handled. You should not assume that a researcher will decide not to see a document based on an Item Level description. A researcher is also likely to want to see other documents in that particular file unit. The materials will still be handled despite the Item Level description.

12. *Should I make Item Level entries in the ANCS+ Item Level-Only directory?*

No. The ANCS+ Archives Module includes both a hierarchical Archives directory and an Item Level-Only directory. The Item Level-Only directory was included in the Archives Module to accommodate Item Level-Only entries that were made in the past. Assuming that Item Level description for a particular collection is absolutely necessary, use the hierarchical Archives directory.

Don’t use the Item Level directory for any new Item Level descriptions. Enter Item Level descriptions into Item Level screens in the hierarchical Archives directory. In cases where a “collection” consists of one document, you should catalog that document individually in the Collection Management Module.

Use of the Item Level directory is not good archival practice. Item Level-only descriptions aren’t grouped logically under the appropriate file unit, series, and collection level descriptions. Instead, they are disconnected from each other and from their parent levels.

If you have Item Level entries in the Item Level directory, determine the collections to which those items belong. Transfer the descriptions to the hierarchical Archives directory as soon as possible.

13. *Why is it so important to enter Item Level descriptions in the hierarchically organized Archives directory and not the item level-only directory?*

Item Level entries in the hierarchically organized Archives directory are linked to the file units, subseries, series, and collections to which they belong. These entries reflect the actual physical organization and the provenance of the collection. The hierarchy also provides context for each document. This makes each item easier to understand and easier to find and retrieve.

Item Level entries in the Item Level directory exist in isolation, with no context, no provenance, and no organization. It's very difficult to find and retrieve items that are entered into the Item Level directory. You must know exactly what document you are seeking and exactly what keywords to use.

T. Folder Title Lists And Finding Aids

1. *What's a "folder title list"?*

A folder title list is also called a "container list." It's a list of all file units in a collection (or in an individual series, subseries, and so forth).

Preparing a folder title list is a highly-recommended alternative to entering a full description for each file unit in a collection. It takes much less time to do a folder title list than to do full file unit descriptions. Folder title lists also provide enough information to be very helpful to users.

You can enter folder title lists at either the Collection Level or the Series Level in the ANCS+ Archives Module. Enter them in the Container List supplemental record.

For technical and practical reasons, it's much better to provide a single folder title list for an entire collection. Use the Container List supplemental record at the Collection Level screen. If you include the folder title list as part of the Collection Level, it will automatically appear in printed finding aids. Folder title lists entered at the Series Level won't appear in printed finding aids.

Note: Refer to Appendix F of the ANCS+ *User Manual* for instructions on completing the Container List supplemental record.

2. *What are the two methods for preparing folder title lists?*

One method is to list the titles of every single file unit in each box. For example:

BOX 1: Aardvarks
Bears
Kangaroos
Leopards

BOX 2: Ocelots
Orangutans
Puffins
Zebras

The other method is to list the first and last file units in each box. For example:

BOX 1: Aardvarks to Leopards
BOX 2: Ocelots to Zebras

3. *Are folder title lists mandatory?*

No. Folder title lists aren't mandatory.

4. *When is it appropriate to do a folder title list?*

Doing folder title lists is a judgment call. Only do them when they can provide information that's not already covered in the basic collection, series, subseries, sub-subseries, or sub-sub-subseries descriptions.

A good candidate for a folder title list is a series of "Subject Files." Subject Files are files containing correspondence, memorandums, research papers, notes, and clippings. The material is on particular topics that were of interest to whoever created the records. Because a series might include dozens or hundreds of individual files, it's impractical to list every topic in the series description. Folder title lists are the most efficient and useful way of informing users of the specific subjects. Users can scan the list of subjects and select desired file units.

5. *When is it unnecessary to do a folder title list?*

In some situations folder title lists are superfluous. For example, suppose a series of memos is arranged in file units by year. All of the memos for a particular year are filed together. The title of each file unit is simply the year. There's no need to list each of the years if the user knows that the series contains one file unit for each year. The title of each file unit, in other words, is implied by the series description. At the most, a folder title list could facilitate retrieval by indicating the first and last file in each box. However, even that's not necessary.

6. *What's a "finding aid"?*

"Finding Aids" are reference tools. They can help NPS staff and outside researchers locate the files and documents they need in an archival collection. They are like a table of contents to an archival collection and can be in either hard copy or digital formats.

A finding aid is the basic tool for navigating through a collection. It should provide an overview of the structure and content of the collection. The standard elements of a finding aid are:

- history
- collection level description
- series and subseries level descriptions
- folder title lists

See Sections R and S for information on history and descriptions. See the beginning of Section T for information on folder title lists.

7. *Does NPS have a template for producing finding aids?*

Yes. A finding aid template exists in the ANCS+ Archives Module. You can generate finding aids from information entered into the ANCS+ Archives Module as part of the description process. Finding aids generated in this way require no additional keying of information. They are produced

from completed fields in the Archives Module.

You don't need to know anything about what a finding aid should look like or what it should contain. Just complete the various fields in the Archives Module as part of your cataloging and description activities. Include folder title lists in the Container List supplemental record on the Collection Level screen. Then choose the FindingAid/SGML function to automatically create a finding aid for the collection.

ANCS+ will copy data from the various fields into a finding aid that has been fully laid out and paginated. It includes a cover sheet, table of contents, and restrictions statement. The ANCS+ finding aid will be in Microsoft Word. You can send electronic copies of the finding aid to users. You can also print hard copy versions or post the finding aid on the Web Catalog.

An example of an ANCS+-generated finding aid appears in **Figure D.6**.

Refer to Appendix F of the *ANCS+ User Manual* for information on completing the fields in the Archives Module. This appendix also contains complete instructions for producing the ANCS+ finding aid.

8. *What are EAD and MARC-AMC?*

EAD stands for Encoded Archival Description. MARC-AMC stands for Machine Readable Cataloging Record – Archival and Manuscripts Control Format.

EAD and MARC-AMC are methods of coding catalog information about archival collections. They are used for posting to national, on-line bibliographic networks.

ANCS+ is capable of automatically putting data about NPS archival and manuscript collections into EAD and MARC-AMC codes. However, your park must have agreements with on-line bibliographical networks in order to post information about park collections. For further information, see the *ANCS+ User Manual*, Appendix F.

9. *Is it mandatory to use EAD or MARC-AMC?*

No. Coding ANCS+ data according to EAD or MARC-AMC format for submission to on-line catalogs is completely optional.

U. Access

This section focuses on access guidelines relating specifically to archives and manuscript collections in NPS custody. General guidance on access to NPS museum collections appears in the *Museum Handbook*, Part III, Museum Collections Use.

1. *Are staff members at my park permitted access to park archival and manuscript materials?*

Yes. Park staff can access park archival and manuscript materials but only for work-related activities. Curatorial staff don't need to withhold any documents from non-curatorial staff who are working on official assignments. Staff members who wish to conduct their own, personal research, however, shouldn't be granted special access. Instead, they should receive the same level of access as a member of the public.

Non-curatorial staff members should follow the same general rules as members of the public when handling archival or manuscript collections. These rules apply whether they're working on an official project or

conducting personal research:

- review original materials only in the museum program’s research room
- have only one folder open at a time
- don’t disturb the order of documents
- don’t remove, add, write on, or otherwise mishandle documents

2. *Are non-NPS staff members permitted access to park archival and manuscript materials?*

Yes. Non-NPS staff members, including members of the public and employees of other Federal agencies, may access park archival and manuscript materials. They must follow certain rules regarding access and certain procedures regarding use. See Section W for information on use of collections.

3. *Is there one set of rules to follow when deciding whether members of the public are allowed to see certain documents?*

No. There are different sets of rules for different types of documents.

- For Federal Records (including NPS records), follow the rules set forth in the Freedom of Information Act. See Section V.
- For donated and purchased personal papers and private sector archives, there may be special restrictions established by the park.

4. *What are the rules for determining public access to a collection of personal papers, private sector corporate archives, or other non-NPS documents?*

Restrictions on access should be outlined in the donor agreement or deed of gift. Accepting donations with restrictions, however, should be avoided. Donated and purchased archival collections that weren’t created by a Federal agency aren’t subject to FOIA. FOIA exemptions don’t apply to such collections. See Section V.

5. *What kinds of “personal privacy” information may I withhold from researchers?*

Personal privacy information in Federal/NPS records may be withheld under the Freedom of Information Act (FOIA). See Section V. Personal privacy information in donated or purchased materials may be withheld under the terms of the donor agreement. It may also be withheld under the park’s policy for protecting personal information.

Parks are legally required under FOIA to withhold NPS records that “would constitute a clearly unwarranted invasion of personal privacy.”

Not every mention of an individual rises to this threshold. The sorts of information serious enough to be considered an “unwarranted invasion of personal privacy” would include:

- medical, psychiatric, employment, and religious counseling information on an identifiable individual or individuals
- information that places an individual in a false light
- information (including photographs) that could cause embarrassment (such as nude images)

6. *Can these types of personal privacy restrictions be placed on non-Federal records as well as Federal records?* As a matter of discretionary policy, parks may handle personal privacy information in non-Federal/non-NPS records, such as personal papers, in the same manner in which they handle personal privacy information in Federal/NPS records. However, these restrictions aren't required by law. Exemptions under FOIA don't apply to personal papers or other non-Federal archival materials.
7. *What types of restrictions may I place on "culturally sensitive" archival materials?* NPS-owned archival collections may contain "culturally sensitive" archival materials such as photographs, motion pictures, maps, location information, or other depictions of American Indians:
- burial sites
 - sacred sites
 - human remains
 - religious ceremonies
- Federal records can be withheld only if they are covered by one of the exemptions in FOIA. However, these materials may be withheld from researchers in the following cases if the materials are:
- Federal records/NPS records, and restriction is authorized by an existing Federal law (such as the American Indian Religious Freedom Act or the Native American Graves Protection and Repatriation Act)
 - donated (and non-Federal), and the donor agreement or deed-of-gift specifies that culturally sensitive documentation should be restricted
 - donated or purchased (and non-Federal), and the park determines that their release would violate the standards of the affected group
- Note:** For further information on restrictions made at the park's discretion, you should consult with DOI solicitors.
8. *How should sensitive information in personal papers or private sector records be withheld from researchers?* Follow the same basic procedures outlined in Section V for withholding FOIA-exempt information from Federal/NPS records.
9. *Should I withhold copyrighted materials from researchers?* No. You shouldn't withhold documents from researchers based on their copyright status. Copyright status may have an affect, however, on making copies of documents for researchers to keep. See Section X.
10. *Is it permissible to restrict or withhold Federal records that have previously been released?* Ordinarily, once a Federal record has been released, especially if it has been published, it becomes part of the "public domain." Materials in the public domain are open to everyone. In very rare cases, however, Federal records identified as "Records of Concern" may be withheld for national security reasons.
11. *What's the principle of "Equality of Access"?* The principle of "Equality of Access" gives the same level of access to all.

<i>If...</i>	<i>Then...</i>
you grant one member of the public access to a particular collection of documents,	you have to grant the same level of access to all members of the public.

Parks are legally obligated under FOIA to provide an equal level of access to everyone requesting to see Federal records. If Federal records aren't exempt from disclosure, then they are open to everyone. If Federal records are exempt from disclosure, then they are closed to everyone.

Follow the same principle with regard to non-Federal records in NPS museum collections.

12. *Can I restrict access to archival or manuscript materials if the purposes or methods of a person's research is questionable?*

No. It's not ethical to censor, judge, influence, or endorse anyone's research, arguments, or interpretations. Access must be granted on an equal basis to all researchers. You cannot withhold publicly available documents from individuals because you don't approve of their research. Neither can you give special access to individuals whose research you support.

For Federal/NPS records, it's illegal to withhold or release a document based on the intentions of the researcher. Instead, you are required by law to make your decision based solely on the content of the documents. Documents that are exempt from disclosure under FOIA guidelines must be withheld from everybody. Documents that aren't exempt from disclosure must be open to everybody regardless of the purpose, nature, or methodology of their research.

V. Freedom Of Information Act (FOIA)

1. *What are the rules for determining public access to NPS or other Federal records that are part of the museum collection?*

NPS records that have been accessioned into park museum collections, such as resource management records, are subject to the Freedom of Information Act (FOIA).

Federal agencies are required to release all information that's not specifically exempted under the Freedom of Information Act.

The Freedom of Information Act applies only to Federal records. Donated personal papers, corporate archives, or other non-Federal archival materials in your custody are not subject to FOIA review.

See **Figure D.7** for a copy of the Freedom of Information Act.

2. *What are some FOIA exemptions?*

FOIA exemptions include:

- security-classified information relating to national defense or foreign policy
- privileged or confidential trade secrets and commercial or financial information

- personnel files, personal medical files, or other materials, but only if disclosure of those records “would constitute a clearly unwarranted invasion of personal privacy”
- law enforcement records, but only if disclosure of those records would:
 - interfere with enforcement proceedings
 - deprive a person of a fair trial
 - reveal a confidential source
 - reveal investigative or prosecutorial techniques
 - endanger the life or physical safety of an individual
- records related solely to a Federal agency’s internal personnel rules and practices
- records of financial institutions
- privileged inter-agency or intra-agency memorandums or letters (for example, concerning management decisions that are under consideration but not yet made)
- records specifically exempted by statute, including records on:
 - protected archeological sites, including shipwrecks
 - caves
 - wells
 - endangered species

Note: FOIA exemptions include records already shielded by existing Federal laws. The Archeological Resources Protection Act of 1979, for example, presents disclosure of protected archeological sites.

3. *What are the procedures for responding to a FOIA request?*

Follow these procedures for responding to a FOIA request:

- Provide written response within 10 working days of receiving a FOIA request.
- If more than 10 days are needed to respond, notify the public affairs and FOIA officers at your park’s regional office immediately. Request an extension.
- The denial of all or part of a FOIA request must be signed by the Regional Director or by the regional FOIA officer or public affairs officer.

- Parks may recover costs (based on fee schedules established by the Department of the Interior) from the requestor if the response:
 - requires more than two hours of research, or
 - entails copying more than 100 pages
- Researchers are entitled to appeal negative decisions. They should file their appeals with the FOIA officer in the Washington Office. If a researcher’s appeal is denied, the researcher may appeal that decision in the appropriate United States District Court.

For further information, consult the FOIA officer at your park’s regional office or read 383 *Department Manual* 15.

4. *How can FOIA-exempt information be removed from files or withheld from researchers?*

There are two ways to withhold documents or information from release:

- If an entire document is exempt, you may remove the document from its original file location. Place it in an acid-free file folder, labeled “Restricted Documents from [file name from which document was removed].” Put a separation sheet in the document’s original file location (see **Figure D.5**). Give the name and date of the document and the FOIA exemption that required the document’s removal. Place a copy of the separation sheet with the document itself. Place the folder containing the withdrawn document behind the original folder.
- If only a portion of a particular document is exempt, then provide the researcher with a “redacted” copy. To do this, make a copy of the original document. Then either obscure the exempted information with a heavy black marker or cut out the exempted information. Copy the redacted copy (so that it’s impossible to see the original information through the black lines). Indicate the FOIA exemption in the margin next to the area that was blacked out or cut out. Provide this copy—not the original document—to the researcher.

Always redact a COPY of the original document. Never cut out or black out information on the original document.

5. *Do I have to conduct a new FOIA review every time a member of the public asks for a particular file or document?*

No. Once a file or document has been reviewed and released, it becomes permanently available to anyone who requests it. There’s no need to conduct additional FOIA reviews for materials that have already been released.

6. *Should I handle all requests for information from archival and manuscript collections as if they are FOIA requests?*

No. Follow FOIA procedures only when responding to requests that are formally identified in writing as FOIA requests. Other letters, e-mails, or telephone calls that you receive may be handled as routine inquiries. See Section U.

Even when responding to a routine request for information, **you must always follow FOIA guidelines when deciding what records can be released and what records should be withheld.**

Never release Federal records that are exempt from disclosure.

7. *Should I review research proposals to determine if it's appropriate to grant access to the records?*

No. FOIA is the only basis for determining whether or not a member of the public can see NPS records.

<i>If...</i>	<i>Then ...</i>
a document or file isn't exempt from disclosure under the FOIA,	release it to everyone who wishes to see it.
a document or file is exempt from disclosure,	withhold it from everyone.

The purposes of the requestor's research, the nature of the requestor's research proposal, and the requestor's research methodologies are irrelevant. The exemptions set forth in FOIA are the sole factor for determining release.

NPS records may never be withheld from an individual because of the nature of his or her research.

8. *Does FOIA apply to all archival and manuscript materials in NPS museum collections?*

No. FOIA is extremely limited. It applies only to certain types of Federal records—records created by Executive Branch agencies. Even within the Executive Branch, it doesn't apply to those offices that are actually part of the White House. This means that the records of all Executive Branch Departments, such as the Department of the Interior, are covered by FOIA. White House records, Congressional records, and Supreme Court records are not covered.

FOIA also doesn't cover:

- records of private sector corporations, non-profit foundations, or clubs
- personal papers of private individuals or families

Therefore, the only records in NPS museum collections that are likely to be covered by FOIA are NPS records.

9. *Are personal papers "records received by the Federal government" and therefore subject to FOIA?*

No. A collection of records may be owned by the Federal government, but that doesn't necessarily mean that they're Federal records. The papers of a private individual or the archives of a private sector corporation may be considered records. If they're accessioned into an NPS museum collection, they're the property of the Federal government, but they are not Federal records.

Federal records are records *created* by the Federal government, and they are records of Federal activity.

When a park accessions a collection of personal papers or corporation archives that it has acquired through donation or purchase, it's not creating

records. Instead, it's acquiring property. They're the papers of a private individual or the records of a private sector company, not the records of the Federal government even though the Federal government owns them.

The fact that this property happens to be a collection of records doesn't make it a collection of Federal records.

W. Use-Reference

This section focuses on guidelines relating specifically to the use of archives and manuscript collections in NPS custody. General guidance on use of NPS museum collections appears in the *Museum Handbook*, Part III: Museum Collections Use.

1. *Are researchers subject to any restrictions on using archival and manuscript collections?*
2. *When members of the public come to the park to conduct archival research, where should they work?*
3. *May researchers be permitted to "check out" files, in the manner that someone would check a book out from a library?*
4. *How should I configure a research room or research area?*

Yes. There are many restrictions that you may place on the use of archival and manuscript materials. These restrictions are outlined below. Researchers who fail to observe those restrictions may be prohibited from doing research in park facilities with original documents. They would still be entitled to purchase copies of publicly available materials.

Designate a separate room or clearly defined area for use by researchers. Don't place researchers at a staff member's desk or at a vacant table in the collections storage area.

No. Original archival materials should never be checked out. They may be placed on loan, following the same rules that govern loans of all NPS museum objects. An archival repository is not a lending library and researchers should never be allowed to check out original documents.

Follow these guidelines to set up a research room or research area.

Location of Research Rooms

- Research rooms or research areas may be adjacent to collection storage areas, but they must be separate from collection storage areas.
- Research areas should be close to collection storage areas. This minimizes the distance that archival materials will need to be transported for use. It also facilitates their quick and easy return to their regular storage locations.
- Research areas must be separate from collection storage areas to ensure proper security. This prevents researchers from having access to any archival materials other than those that they have specifically been permitted to use.

Contents of Research Rooms

- Research areas should be "clean." There should be no books, papers, files or other materials besides the documents that researchers have been authorized to use. This prevents archival materials that are brought to researchers from getting mixed up with other documents.
- Provide one or more worktables for researchers. Two or more researchers can be seated at the same table if they're working together

as a team. The team should be using the exact same documents at the exact same time. Otherwise only one researcher should be seated at a table at one time. Having two or more researchers at a single table runs the risk of getting papers from different collections mixed up. There are specially designed research tables with dividers to separate researchers (and the files they are using) from each other. These allow several researchers to work at the same table.

- Don't allow waste paper baskets or other trash receptacles near researchers. This prevents documents from being discarded by accident or through malice.

Environmental Conditions for Research Rooms

- Environmental conditions in research areas (heat, light, humidity) should be comparable to environmental conditions in collection storage areas.
- No food or beverages may be brought into research areas. Integrated Pest Management procedures should be implemented in research areas, just as they are in collection storage areas.

Security for Research Rooms

- Place lockers outside the research area, where researchers can store coats, hats, and briefcases. This is a security measure rather than a convenience for the researchers. It's intended to reduce opportunities for researchers to hide documents in their belongings and sneak them out of the research area.
- There must be a counter or desk for staff use in the research room. Situate it in such a way that staff can monitor all researchers at all times.
- Research areas should be secure. Grant entry only to authorized staff and authorized researchers. If a research area should abut a collection storage area, keep the doors locked between the two areas. This is especially important when researchers are present. Keep research areas locked or otherwise secured to prevent park visitors (other than authorized researchers) from gaining access to archival materials. This also prevents researchers from smuggling documents to someone outside the research room.

5. *What procedures should staff follow when working with on-site researchers?*

Staff are responsible for enforcing the research room rules and guidelines.

Retrieving Materials

Staff are responsible for retrieving and refiling all materials requested by researchers. Never allow researchers into the collection storage area to retrieve the papers they'll be using. Staff may pull several boxes of materials for a researcher at a time. However, the researcher may only use one box—and one folder out of that box—at a time. The researcher must put a folder back into the box before pulling another folder out. He or she must return everything to the first box and close it before opening the next box.

Monitoring

At least one staff member should remain in the research area at all times to monitor researcher activities. Staff should ensure that researchers are following the rules. In particular, staff should watch for any actions by researchers that might result in damage or rearrangement of documents. They should also be alert to any attempts by researchers to conceal documents on their persons or among their effects.

Inspecting

Staff should inspect all notes or other objects removed from the research room. Make certain that no documents are included among them.

6. *What procedures should researchers follow when they're in the research area?*

Researchers must follow these procedures when they're in the research area. Prohibit researchers from the research room if they fail to observe these rules:

- A researcher should use only one box at a time. No matter how many boxes of archival materials have been brought to a researcher, only one box may be opened at a time. Only one file folder from that box may be used at a time.
- Researchers must keep documents in the same order in which they found them. They should never move a document from one folder to another, or folders from one box to another. If researchers discover a file or document that has been misfiled, they shouldn't attempt to correct the situation themselves. They should report it to staff.
- Researchers should never write on archival materials.
- Researchers must handle individual documents carefully. If they're handling photographs or documents that are damaged or fragile, staff may require them to use gloves. The park should provide gloves to reduce the risk of damage. If researchers damage a document in the course of doing their research, they should report it to staff immediately.
- Researchers must never attempt to remove documents from the research room, unless museum staff give them permission to do so.
- If researchers are taking notes, they should use their own laptop computers. They can also write notes down on paper using *pencils* only. Never permit pens in the research area. Researchers must never use pens in the vicinity of original documents.
- Researchers are not permitted to have food, beverages, or smoking materials in the research area.
- Researchers should refrain from using cell phones or the Internet while in the research room. This is to avoid disturbing other researchers.

7. *What forms should I require researchers to complete?*

Require each researcher to complete the following forms:

Registration Form

Each researcher should complete a registration form before being permitted to use archival materials at the park. The form should include name, address, institutional address, research project, and publication plans. See **Figure D.8**. Upon completing the form, researchers should present both the form and a government-issued photo ID to a staff member. Write the type of ID and the ID's control number on the form.

Request Form

Require each researcher to complete a request form for all materials he or she wishes to view. The form should indicate the researcher's name, the date of the request, and the specific boxes, series, or files being requested. Retain request forms indefinitely, to identify individuals who had access to particular materials. This is in case you discover any missing documents. A "paper trail" of research use can deter theft. It can also serve as evidence in court cases seeking to recover lost or stolen items.

Copyright and Privacy Restrictions

Each researcher should read and sign the Copyright and Privacy Restrictions form before being permitted to use archival materials at the park. See **Figure D.9**.

Access Policies and Rules Governing Use

Each park should prepare and post its own Access Policies and Rules Governing Use for researchers to read. See the sample list of rules, **Figure D.10**.

8. *Do researchers need to meet any age restrictions?*

Archival repositories commonly prohibit individuals under the age of 21 from entering research areas and using original archival materials. Sometimes repositories make exceptions for college students working on class projects that require the use of primary sources.

9. *Should researchers make appointments before arriving to do archival research?*

Appointments are recommended but not required. Researchers should contact museum staff before they visit in order to make sure that the:

- papers they are seeking are actually in park custody
- papers in question contain the sort of information they are seeking
- materials they wish to see are available to researchers and are not exempt from disclosure

In addition, space constraints may make it advisable for researchers to make appointments to use the research area. Parks with limited space may be able to accommodate only two or three researchers at a time. Parks can handle researchers on a "first come, first served" basis. However, it may be fairer and more efficient for parks to schedule researchers in advance for specific blocks of time.

10. *What other scheduling and logistical arrangements should parks make in order to protect and facilitate the use of archival materials by outside researchers?*

Parks may make additional scheduling and logistical arrangements to facilitate researchers and protect the collections:

Pull Schedules or Retrieval Schedules

- Parks may establish “pull schedules” or “retrieval schedules,” especially if there is heavy demand for archival materials. These schedules set certain times during the day as deadlines for researchers to submit requests for archival materials. The times are usually at least once in the morning and once in the afternoon. Requests received by those times ordinarily should be filled within the next one or two hours, depending upon demand. Researchers missing a deadline would have to submit their requests for the next deadline.

Supplies

- To protect the documents, parks should have supplies of white cotton gloves and pencils. Make these available for researchers to use when working with original documents.
- As a security measure, parks may also wish to provide researchers with notepaper or note cards. These should have holes punched in the upper right corner. When researchers are leaving the research room, staff can suspend a sheaf of pages or cards by inserting a pencil through the hole. Any original documents that might have been hidden among the notes would then drop out.

Use Copies; Reference Copies

Particular collections (or portions of collections) may be damaged, fragile, or receive exceptionally heavy use. Parks may choose to make photocopies, microform copies, or scanned digital copies of those materials. Researchers could then use those “reference copies” instead of the originals. (**Note:** If you make reference copies of accessioned archival materials, you should not catalog them. They are just copies, and are not part of the collection itself).

11. *How should parks provide copies of documents to private researchers?*

If at all possible, parks should provide facilities for making copies of documents, preferably at the researcher’s expense.

Don’t allow researchers to make copies themselves. They should indicate to staff which documents they wish to have copied. No matter what type of copies a researcher requests, he or she should complete a Researcher Duplication Form. See **Figure D.11**.

The park may adopt various procedures for making copies.

Small Numbers of Copies

Researchers may bring individual documents or files to staff in the research area for immediate copying. This depends on the availability of staff and photocopy machines. Preferably, the park should set up a cost-recovery program, so that researchers will bear the expense of copying. It might be possible to set up such a cost-recovery program through the park’s cooperating association or through the park’s budget office. The park may

waive fees, however, for very small numbers of copies that incur negligible costs.

Large Numbers of Copies

Researchers may need more than one or two documents photocopied during their visits. In these cases, it's advisable for them to use strips of white paper as "bookmarks." The paper indicates the location of specific documents or files that they wish to have photocopied. The staff makes the copies at a time that's convenient. These "bookmarks" should be placed so that they stick up above the file folders as they sit in a box. They're then readily apparent to staff. Researchers should write the title of the document or file unit on the bookmark (in pencil). This prevents confusion over what they want to have photocopied. The park should have cost-recovery procedures in place so that researchers pay for the photocopies themselves. The park may choose to withhold copies until full payment is received.

Photographic Copies

Researchers may desire actual photographs of textual documents, duplicate negatives of photographs, or copies of motion pictures or videotapes. In such cases, the park may set up agreements with commercial photo labs or video labs to make these copies. The park would transport the items to the lab and retrieve them after the copying is completed. The lab would then be responsible for collecting payment from the researcher. Alternatively, the park could pay the vendor and then charge the researcher through its cost-recovery program.

Note: Do not charge park staff for copies made in connection with official work assignments. If a park staff member wishes to conduct personal research while off duty, however, he or she should be subject to the same cost-recovery provisions as members of the public.

12. *What are the procedures for responding to researchers who aren't on-site?*

Instead of actually visiting the park, researchers may contact the park via regular mail, e-mail, or telephone. They may request information from or access to archival or manuscript materials in the park museum collection. Follow the procedures listed below when responding to those requests.

Response Format

- Responding by letter is always acceptable, but you may respond in whatever format the request was made. For example, you may respond to e-mail requests by e-mail and to telephone requests by telephone.

Response Time

- Respond as quickly as possible. Remember that FOIA responses must be sent within 10 working days.
- If providing a full answer would take a great deal of time, send an interim response. Provide as much information as possible and indicate that additional information will be contained in a follow-up response.

- If a researcher requests a few easily-provided facts, it's acceptable to provide those facts. In general, however, you shouldn't do the researcher's work. Focus on the availability of archival materials and on their general content. Provide finding aids for researchers to review. As a general rule, don't research questions that will take more than an hour or two to answer. Instead, advise the researcher to review the archival materials at the park, or purchase copies of relevant files.

FOIA Requests

- For formal FOIA requests for Federal/NPS records that are covered by FOIA, follow the procedures outlined in Section V. Withhold restricted information by applying the exemptions listed in Section V.
- If a researcher doesn't formally identify the request as a FOIA request, you don't have to follow the procedures outlined in Section V. This rule applies even if the request is for Federal/NPS records that are covered by FOIA. You should still respond, and you should still withhold restricted information by applying the exemptions listed in Section V.

Non-Federal Records Requests

- A researcher may request personal papers or private sector records that aren't Federal records. Apply whatever restrictions are contained in the donor agreement or in discretionary park policy.
- A researcher may submit a formal FOIA request for personal papers or private sector records that aren't Federal records. Advise the researcher that the materials in question are not covered by FOIA. Then respond as you would to any non-FOIA request for non-Federal archival materials.
- If you identify any archival materials that may relate to a researcher's request, provide a very brief description of those records. Include estimated page counts. Then, unless the materials are restricted, offer to make them available to the researcher in the park's research room. Explain to the researcher how he or she can order copies of the materials. When sending copies to off-site researchers, include a copy of the "Copyright and Privacy Restrictions" form. See **Figure D.9**.

Fees for Research Requests

- As noted in Section V, "Freedom of Information Requests," your park could establish a cost-recovery program that would require researchers to pay for research services, based on fee schedules established by the Department of the Interior. See *Museum Handbook III*, Chapter 4.

Tracking Research Requests

- Keep paper copies of incoming and outgoing letters and e-mails involving substantive information on archival holdings at your park.

- Keep track of all responses, regardless of format (letters, e-mail, telephone, face-to-face). Report the number of inquiries in your park's annual CMR submission.

X. Copyright

1. *May I give researchers copies of copyrighted materials?*

You may provide single copies of copyrighted documents to individual researchers if the:

- copyright holder has granted permission, *or*
- copies are made under the "Fair Use" provision of the copyright law

"Fair Use" permits the copying of documents without the approval or even the knowledge of the copyright holder. Fair Use covers such purposes as:

- research and scholarship
- news reporting
- criticism, parody, or commentary
- preservation of original documents (for example, making reference copies of a document for researchers to use in order to avoid wear-and-tear on the original)
- deposit of a copy in another research institution for scholarly purposes

2. *Are materials in NPS-owned archival and manuscript collections copyrighted?*

Sometimes they are. It depends on the type of material and the stipulations of donor agreements.

Federal records (such as NPS records) generally are not copyrighted. Letters, memorandums, speeches, notes, or other documents prepared by Federal employees as part of their official duties are *never* copyrighted. Those documents are in the public domain unless they are exempt from disclosure under FOIA. Documents received from other sources and incorporated into official files, however, may have copyright protection.

Personal papers, the records of private sector corporations or non-profit associations, and other donated or purchased materials may have copyright protection.

3. *How will I know if a document has been copyrighted?*

In many cases you won't know. Here are some useful indicators:

- Documents written by government employees as part of their official duties aren't copyrighted.
- Donors of personal papers or other non-Federal archival collections may assign all copyrights to the NPS. This should be documented in the donor agreement or deed of gift.
- Published documents usually include a copyright statement. Unpublished documents usually don't, but that doesn't mean they don't have copyright protection.

- Photographs may be stamped on the back with copyright information.
- Copyright protection may have expired on older documents. However, there are many variations, and it may be necessary to consult with a copyright lawyer before making a final determination. Generally, copyright protection has expired on:
 - published works that are more than 75 years old
 - unpublished works that are more than 100 years old

4. *Who's responsible for determining if a document has copyright protection?*

The researcher—not the park—is responsible for determining the copyright status of documents.

The only time a park needs to determine the copyright status of a document is if it plans to include the document in an official NPS publication.

5. *When should parks grant permission to publish copyrighted materials?*

Parks should only grant permission when they are certain they hold the copyright on a particular document. The NPS Deed of Gift form explicitly states that copyrights are being turned over to the NPS. If there is a signed deed of gift that includes the copyright transfer, then it's acceptable to grant permission to publish.

In other cases, however, you should avoid either giving permission or withholding permission:

- No permission is needed to publish Federal records because Federal records cannot be copyrighted.
- No permission is needed to publish documents whose copyrights have lapsed, because they are in the public domain.
- The NPS doesn't have the authority to grant or refuse permission if the NPS:
 - knows that another party owns the copyright on a particular document
 - doesn't know if a document is copyrighted

6. *What warnings or guidance should I give to researchers regarding the use of copyrighted materials?*

Unless you're certain that a document is in the public domain, or that the NPS owns the copyright on a document, you should do the following:

- Warn the researcher that the document may have copyright protection.
- Advise the researcher that he or she is responsible for determining copyright status.
- Advise the researcher that he or she is responsible for obtaining permission to publish from the copyright holder.
- Ask the researcher to sign the NPS "Copyright and Privacy Restrictions" form (see **Figure D.9**)

- Refer the researcher to the Copyright Search System of the U.S. Copyright Office: <http://www.copyright.gov/records/>.
- Refer the researcher to the National Archives Source and Permission Contact List: <http://www.archives.gov/research/>.

7. *Where may I find guidelines for determining if materials are likely to be in the public domain?*

Consult “Copyright Term and the Public Domain in the United States” at http://www.copyright.cornel.edu/public_domain/.

Y. Use—Publications, Exhibits, Loans

1. *How should researchers cite NPS-owned archival materials that they have used?*

The standard method for citing documents in scholarly works is to go from the specific to the general (that is, from the individual document to the repository or agency). Under this formula, citations for NPS archival and manuscript collections should indicate the:

- title and date of the document
- title of the file unit
- title of the series/subseries/sub-subseries
- title of the collection
- name of the park
- National Park Service

NPS has also recommended providing citations that start with the general and move to the specific. Under that method, the order of the elements listed above would be reversed. Either method is acceptable.

Citations, however, are entirely the responsibility of the researcher, and researchers are under no obligation to follow NPS recommendations.

Note: A researcher’s willingness to follow NPS citation recommendations must never be a factor in deciding whether to provide or withhold archival materials.

2. *May the park request a complimentary copy of publications based on NPS-owned archival or manuscript collections?*

The park may *request* a courtesy copy, but cannot require one. A researcher’s willingness to provide a courtesy copy must never be a factor in deciding whether to provide or withhold archival materials.

Previous guidance recommended two complimentary copies—one for the park library and another for the museum collection. This may tax both the researcher’s generosity and the ability of museum staff to handle additional materials. A single library copy is sufficient.

3. *Can I loan archival materials?*

Yes. Parks are permitted to loan documents to museums and other institutions. Parks may not loan archives to individuals. Loans of documents must follow the same procedures as loans of other types of museum objects. Follow the procedures outlined in the *Museum Handbook*, Part II, Chapter 5.

Although it's inappropriate to catalog each document individually, it's permissible to catalog individual documents for a loan. You'll then have a unique catalog number to cite in the loan agreement. Alternatively, you can complete an Item Level record in the Archives Module. You would use the local collection number (which would include the item number) on the loan agreement.

4. *May archival materials be used in park museum exhibits and in park interpretive programs?*

Yes, but only if strict guidelines are observed.

- Exhibit-quality color photographs can be taken of documents, for inclusion in displays. For both preservation and security purposes, this usually is preferable to displaying original documents.
- Original documents may be displayed, but only if they are protected by UV filters. The documents must be housed in conditions that meet all security and environmental standards. It's preferable to display photographs of documents rather than original documents. Documents placed on exhibit must have either a unique catalog number or a unique Archives Module number (see item 3, above).
- Documents can be published for general distribution only if:
 - they're Federal records
 - they're in the public domain
 - donor agreement/deed of gift has relinquished copyright ownership to the NPS
- Original documents and photographs of documents cannot be published or placed on exhibit if they're:
 - exempt from disclosure under FOIA
 - restricted under donor agreement/deed of gift
- Never allow visitors to handle original documents, unless they're authorized researchers working in the research area.

Z. Understanding the Language: A Glossary

Acquired archives: Organic collections created by a non-NPS organization as a routine part of doing business but removed from the physical custody of the originating institution and now in the physical custody of the NPS. These intact organic collections maintain their provenance and original order and are still referred to as archives, although legally severed from their non-NPS creator.

Active records: Official records needed and used for current business by NPS staff.

Administrative value: Refers to the archival material's usefulness for park management, as in the case of architectural drawings and plans useful for building repairs, maps necessary for landscaping or rescue, or other park records that indicate how an ecosystem has been affected over time.

Appraisal: (1) The act of assessing an archival or manuscript collection's value--including informational value, artifactual or intrinsic value, evidential value, associational value, and monetary value--using criteria such as age, subject content, contextual documentation, condition, quality, quantity, legal restrictions, organizational problems, public relations concerns, and associational nature. (2) The act of determining if a collection contains official (i.e., appropriate for disposition by NARA) or non-official (i.e., appropriate for park retention) records by consulting guidance such as *Cultural Resource Management Guideline*, Chapter 9; *Museum Handbook*, Part II, Appendix D, Section D; and *NPS-19, Records Management Guideline*. (3) Used in NPS museums to refer strictly to establishing monetary value.

Archival assessment: Evaluation of a park's total archival and manuscript collection management needs incorporating collection surveys, the production of collection-level survey descriptions, collections evaluations, and recommendations for action. Professional assessments facilitate records management and the care of archival collections in parks that have little previous experience with these issues.

Archival collections: (1) An organic accumulation of records created by an organization as a natural part of conducting business. Archival collections have a common provenance and a shared internal order original to the collection. See **collection**. (2) The total archival and manuscript holdings of a park. See **holdings**.

Archival quality: Permanent, durable, and non-destructive storage or copying materials or equipment suitable for use with archives. Also refers to long-lived (100-year-plus) documentation formats such as silver gelatin emulsions.

Archives: (1) The non-current records of an organization, with their original order and provenance intact, maintained by the original organization. (2) The organization that created and holds the records. (3) The physical building/room in which the records are held.

Archivist: A professional knowledgeable in archival theory and practice, who is responsible for the administration or management of archival and manuscript collections.

Artifactual value: refers to the collection or item's intrinsic value as unique or rare examples of material culture. This value relates to the age, format, process, media, condition, and quality of the material.

Artificial collections: See **non-organic collections** and **assembled collections**.

Assembled collections: Accumulations of documents, most often gathered from multiple sources by a collector, generally unrelated by provenance. The documents frequently are in the same format or related to the same topic. Assembled collections are sometimes referred to as "manuscript collections."

Associated records: All documentation generated by the activity of collecting or analyzing artifacts or specimens needed to effectively manage those related objects within museum property collections. (If there is no object or specimen, the record may not be “associated” but is instead a resource management record.) See also the definition in 36 CFR Part 79 and **resource management records**.

Associational value: Refers to the archival material's relationship, usually by ownership or use, to an eminent site-related individual or group or the material's relationship to a significant site-associated event.

Authority files: Published or unpublished lists of subject terms or names selected by a park for use in description. The lists may provide definitions, occupations, cross-references from variant versions of names or terms, and dates. Every park museum collection with archival holdings should have authority files for use in creating folder lists.

Cellulose nitrate film: A flexible film base used for motion picture film and photographic negatives between about 1890 and 1955. This film base self-destructs over time going through five stages of deterioration. The film should be handled with gloves, foldered in buffered sleeves, boxed, placed in Ziplock bags and removed to off-site (non-museum storage) storage in a freezer. See MH-I, Appendix M, Care of Cellulose Nitrate Film.

Collections: (1) An accumulation of manuscripts, archival documents, or papers having a shared origin or provenance, if organic; or having been assembled around a common topic, format of record, or association (e.g., presidential autographs), if non-organic. A collection may be any of the types of records described in section D (e.g., personal papers, organizational records, assembled collections, resource management collections, or sub-official records). (2) The total archival and manuscript holdings of a park.

Context: The circumstances of creation, history of ownership and usage, and original order of an archival or manuscript collection. A clear context gives a collection enhanced research value. See also **original order**, **organic collection**, and **provenance**.

Document: (1) Also called an “item,” the smallest complete unit of record or manuscript material accumulated to form a file (e.g., a letter, photograph, or report). A document may consist of multiple sheets or may have a recto (front) and verso (back), both of which carry information. Documents are also referred to as archival collections, papers, records, and manuscripts. Documents are most clearly described when referred to by their specific formats and processes (document types), such as albumen stereographs, outgoing correspondence, diaries, ink drawings, or field notebooks. (2) Any information in a fixed format, regardless of type.

Ephemera: A broad category of documents originally created for temporary or short-term use, such as advertisements, broadsides, invitations, packaging, posters, programs, schedules, and tickets.

Evidential value: Refers to the collection's ability to serve as historical or legal proof of an activity, event, procedure, or process since the record(s) are byproducts of these activities.

Federal Records Centers (FRC): Regional repositories that serve as official records centers for the National Archives.

File unit. The second-lowest level of archival arrangement, immediately above individual items or documents. File units contain all of the documents that the records creator filed together under a particular heading, classification, or topic. “File units” are not to be confused with “file folders,” which are merely physical containers for holding documents. A single file unit, in fact, may be so large that it requires multiple file folders.

Finding aid: (1) A broader term for any format of textual or electronic tool that assists researchers in locating or using archival and manuscript collections. Basic finding aids include guides (for example, repository, collection, and subject guides), descriptive inventories, accession registers, card catalogs, special lists (for example, shelf and box lists), indexes, and (for machine-readable records) software documentation. (2) The file

guides, indexes, registers, and filing system aids produced by the records creator, usually referred to as “control records” or “contemporaneous finding aids.”

Format: Refers to the document type or form, such as the document's size and shape or the configuration of the media and support. For a fuller description of document types or formats see the Getty Art History Information Program's *Art and Architecture Thesaurus*, 2nd edition, (Oxford, England: Oxford University Press, 1994) for a full hierarchical list of terms.

Genre: Refers to the document's style, content, and form, including the document's purpose (advertisements, presentation album), the document's viewpoint (panoramic view), broad topical category (landscape, still life, portrait, or street scene), method of representation (abstract, figurative), circumstances of creation (amateur works, student works), or function (dance cards, cigarette cards, death certificates). For a full list consult the *Thesaurus for Graphic Material II: Genre and Physical Characteristic Terms*, 2nd ed., 1993, Library of Congress Cataloging Distribution Service, Washington, DC 20541.

Holdings: The sum total of all archival and manuscript collections held in physical custody by a park. See also **archives**, **collections**, **physical custody**, and **repository**.

Holographic documents: Documents written in the handwriting (i.e., script) of the individual who created or signed them.

Informational value: Refers to the subject content of the archival collections, such as the people, groups, places, eras, activities, events, objects, projects, and processes documented.

Integrity: Refers to collections whose provenance and original order are intact and whose documentary context is complete.

Intellectual control: The mastery or command established over the informational and contextual content of archival and manuscript collections resulting from discovering and describing their provenance and original order and from the processes of arrangement and description.

Intrinsic value: See **artifactual value**.

Inventory: (1) A structured guide to an archival or manuscript collection that includes a brief history of the collection and a list of the materials arranged in series that functions as a type of finding aid. (2) A physical count of a collection conducted for accountability purposes. See MH-II, Chapter 4, Section A, Annual and Spot-Check Inventories and Audits. See also **survey**.

Items: Refers to individual documents or manuscripts. An item may be composed of multiple sheets or may have both a recto (front) and a verso (back) with writing or images on both sides.

Leaves: See **sheets**.

Lot: A group of related records cataloged with a single ANCS catalog record.

Manuscript collections: Groups of documents that have been assembled due to their individual literary or historical values. Manuscript collections are frequently contrasted with archives, which have a shared creator, a shared history of ownership, and a shared original order. See also **manuscripts**.

Manuscripts: Individual documents, primarily textual, that have literary or historical value. Manuscripts include a wide range of document types from correspondence, book drafts, and diaries to personal papers and resource management records. Manuscripts are often paper-based textual records.

Monetary value: Refers to the dollar value placed on rare or collectible manuscripts such as autograph letters or photographs. Monetary value is affected by all of the other values listed above.

Museum records: Official records generated by the museum property system to manage museum property, such as accession, catalog, inventory, and loan records. These records are appraised through NPS record schedule procedures (NPS-19). NPS-19 states that they are maintained in the parks as active official records for which the NPS is accountable to the National Archives and Records Administration.

Non-organic collections: A synonym for “assembled or artificial collections.”

Non-records: Documents not covered under the Federal Records Act; documents that are not considered records created or received by the Federal Government. (**Note:** Do not confuse archival collections received by the park through purchase or donation as “record material” by virtue of their having been “received” by the park. Such materials in fact “non-record” because they are not received as a record of Federal activity; rather, they are acquired as museum property).

Organic collections: Files routinely created as part of the day-to-day activities of a person, group, or organization. The records have a systematic relationship to each other that reflects their function and the activities and viewpoint of their creator. Organic collections are sometimes referred to as “archives.” They are said to exhibit integrity (their provenance and original order has been retained). Personal papers, organizational records (acquired archives), resources management records (including associated records), active records (including museum records), and inactive records may be organic. See **original order**, **provenance**, and **non-organic collections**.

Organizational records: See **acquired archives**.

Original order: The functional filing arrangement imposed on a document collection by its creator. The original order of collections can provide information not found elsewhere, such as when the creator received a communication, who reviewed a document, or what the sequence of an administrative activity was. Original order should be preserved or reconstructed in a collection as it allows for rapid arrangement, accurate contextual research, and additional insight into the record creator's methods and activities. If a collection has no order because of mismanagement or disaster, a decision to impose an order may be made only by an experienced archivist.

Personal papers: The records created or accumulated during a lifetime by an individual or family. They have an intact provenance and an original order. Personal papers differ from archives in that they are routinely removed from the custody of the collection creators and placed in external archival repositories, but they function as the archives of individuals and must be treated with the same respect as all organic collections. Parks may collect the personal papers of individuals related to the park, such as founding fathers, formative staff, or eminent individuals associated with the history of the site.

Photographs: A fundamental document type found in all categories of records from museum records to assembled collections. Photographs come in many formats (for example, from cartes-de-visites to stereographs), in a wide variety of vantage points (for example, bird's-eye-view, microscope images, satellite images), genres (for example, landscapes, still lifes, portraits), and processes (for example, silver gelatin, carbon). Photographs are formed by the action of radiation (usually light) upon a sensitized surface. While often thought of as a single process, photography is many hundreds of related chemical processes on a variety of supports, such as metal, paper, plastic, or glass.

Photomechanicals: Multiple copies of images made in ink from photographic printing plates. These permanent images include chromolithographs, duotones, halftones, offsets, photolithographs, photogravures, photoengravings, silkscreens, and Woodburytypes. Photomechanical reproductions were most commonly used for postcards and for illustrations in books, magazines, and newspapers.

Physical custody: Either temporary or permanent custody of an archival or manuscript collection. Physical custody does not entail intellectual control or copyright (the right to exhibit, publish, or prepare derivative works). This is particularly true for previously unpublished personal papers, organizational papers, or other historic manuscript collections. In general, the creator of the records holds the copyright. Nor does physical custody entail the right to dispose of portions of the collection without appropriate permission.

Provenance: (1) The entity (for example, person, family, organization, or office) that either created the records or accumulated them in the natural course of activity. (2) The history of physical custody of a collection or item. Note: Museum curators and archeologists use the related term “provenience” to refer to the source or origins of objects and to the exact location where the object was found or made.

Provenience: See **provenance**, definition 2.

Records: (1) All information fixed in a tangible (textual, electronic, audiovisual, or visual) form that was created by an organization as part of its daily business. (2) Two or more data fields that are grouped as a unit in machine-readable records. (3) Official NPS records, as defined by the Federal Record Act and described in DO-19 and NPS-19. These NPS records are organic collections of documentary materials created by the National Park Service to document the creation, development, organization, functions, policies, decisions, procedures, operations, or other routine activities of the NPS. They are made or received by NPS offices as a part of transacting business and preserved as evidence of the offices' actions or functions or because of the records' informational value. They may be active, in which case they are retained by the NPS, or inactive, in which case they are appraised via NARA records schedules and either disposed of or sent to a federal records center.

Records management: The process of determining the status, value, and disposition of park records throughout their lifetime (for example, official or non-official; active or inactive; appropriate to the park's scope of collections statement or not; relevant to the site's history or not; appropriate to the archival appraisal criteria or not; and appropriate for shipment to the FRC and NARA or not as listed on the records schedule). Records management also involves scheduling records for their ultimate disposition.

Recto: The facing page (front) of a single sheet of text or images.

Reformatting: Preservation duplication of original archival materials through the use of long-lived copy technology such as silver halide microfilms or large format digital files and computer output microfilms.

Separation Sheet: A form used to indicate the location of removed items within a collection and the reason for the removal.

Series: A group of documents arranged, file units, or volumes maintained together as a unit within an archival or manuscript collection because of their shared circumstances of creation, receipt, or use. Examples of series would include: 1) incoming correspondence, 2) outgoing correspondence, 3) project files, 4) annual reports, and 5) fiscal records. File units within a series usually conform to a single, consistent arrangement scheme (alphabetical; numerical; chronological, etc.). A series containing records arranged under two or more filing schemes should be divided into subseries, with each group of file units sharing a given filing scheme making up a subseries. Also see **subseries**. **Note:** If a collection is to be organized into series, there must be two or more of them. There is no such thing as a collection that is “organized” into one series. A collection may be made up of file units or individual documents that are not organized into series. If a collection is organized into series, however, then all file units or documents must fit into one of those series – even if a separate series must be established for a single item.

Sheets: Individual leaves of paper, for example a 5-page letter. An individual sheet may have both a recto (front) and verso (back).

Special collections: (1) Non-official collections of manuscripts, personal papers, non-federal corporate records, magnetic media, audio-visual materials, and other documents. (2) Non-textual records, such as magnetic or audio-visual materials.

Sub-series: A group of documents subordinate to a series, and maintained together because of their shared circumstances of creation, receipt, or use. It may be necessary to break a series up into two or more subseries because records created under the same circumstances serve different functions, cover different topics, or are arranged according to different filing schemes. See **series**.

Survey: A comprehensive and systematic review of a collection conducted either to obtain a brief overview of a collection or a park's holdings or to gain knowledge on a particular point, such as the amount of cellulose nitrate-based negatives and film in a repository, or the physical condition of a group of collections, or the level of conservation treatment needed by specific items. Surveys may be conducted on any level (item to repository) and on any topic (for example, the amount of stereographs in a repository or the level of documentation on women in the NPS).

Textual records: A broad category of written record including holographic, typed, word-processed, and mechanically printed documents, manuscripts, records, and archives.

Verso: The reverse side (back) of a single sheet of text or images.

Visual records: A broad category of records containing images including graphic, photographic, and photomechanical prints (in all formats from negative, interpositive transparency, and slide, to print); drawings; paintings; and watercolors. Visual materials may be found in all categories of records from official museum records to resource management records.

AA. Identifying Further Sources of Archival Training and Guidance

Seek further training through NPS archival training, your local universities, the National Archives and Records Administration's Modern Archives Institute, the Society of American Archivists' training courses, and through your regional archival organizations.

The Society of American Archivists offers regular training courses. Contact them at tel: 312-922-0140; e-mail at <info@SAA.mhs.compuserve.com> or @cserve<internet:archives@miamiu.acs.muohio.edu> or via fax at 312-347-1452. Their address follows in the bibliography section.

For further guidance read Federal regulations governing document creation, use, and management including the following: the *Records Disposal Act of July 7, 1943, as amended (44 USC 366-376, 378-380)*; the *Federal Property and Administrative Services Act of 1949, as amended (44 USC 391-401)*; *Federal Property Management Regulations, Subchapter B, Archives and Records, Part 101-11, Records Management*; Department of the Interior *Departmental Manual, Parts 380-384, Records Creation and Disposition and Part 411, Official Records*; and the *Federal Property Management Regulations, Subchapter B, Archives and Records*.

BB. Readings: A Bibliography

Source Key:

Items marked with an * are available from: the Society of American Archivists, 600 South Federal, Suite 504, Chicago, Illinois 60605, tel: 312-922-0140.

Items marked with a ^ are available from: the American Library Association, 50 East Huron Street, Chicago, Illinois 60611, tel: 312-944-6780.

Items marked with an @ are available from: the Library of Congress Customer Services Section, Cataloging Distribution Service, Washington, DC 20541-5017, tel: 202-707-9797.

Items marked with a # are available from: the National Archives and Records Administration, 7th & Pennsylvania Ave., NW, Washington, DC 20408, tel: 202-707-5240.

Items marked with a > are available from: the Commission on Preservation and Access, 1400 16th Street, NW, Suite 740, Washington, DC 20036-2217, tel: 202-939-3400.

Items marked with a % are available from: the Smithsonian Institution Press, 955 L'Enfant Plaza, Room 7100, Washington, DC 20560, tel: 202-287-3738.

Items marked with a + are available (free) from: UNESCO, Place de Fontenoy, 75700, Paris, France.

Items marked with a \$ are available from: the American National Standards Institute, 11 West 42nd Street, N.Y., N.Y. 10018; tel: 212-642-4900 or via the Association for Information and Image Management at 1100 Wayne Ave., Suite 1100, Silver Spring, MD 20910; tel: 301-587-8202.

Unmarked items may be borrowed via interlibrary loan from your local public or university library. Articles only may be requested via interlibrary loan from the DOI Library.

Basic Readings:

*Association of British Columbia Archivists, Small Archives Committee. *A Manual for Small Archives*. British Columbia: Association of British Columbia Archivists, 1988.

*Bellardo, Lewis and Lynn Lady Bellardo. *A Glossary for Archivists, Manuscript Curators, and Records Managers*. Chicago: Society of American Archivists, 1992.

Cook, Michael. *Archives Administration: A Manual for Intermediate and Smaller Organizations and for Local Government*. Folkestone, England: William Dawson & Sons, 1977.

*Cox, Richard J. *Managing Institutional Archives*. New York: Greenwood Press, 1992.

*Daniels, Maygene and Timothy Walch, eds., *A Modern Archives Reader: Basic Readings on Archival Theory and Practice*. Washington, DC: National Archives Trust Fund Board, 1984.

*Ellis, Judith, ed., *Keeping Archives*. 2nd ed., Australia: Australian Society of Archivists and D.W. Thorpe, 1993.

*O'Toole, James M. *Archival Fundamentals Series: Understanding Archives and Manuscripts*. Chicago: Society of American Archivists, 1990.

*Pugh, Mary Jo. *Archival Fundamentals Series: Providing Reference Services for Archives and Manuscripts*. Chicago: Society of American Archivists, 1992.

*Wilsted, Thomas and William Nolte. *Archival Fundamental Series: Managing Archival and Manuscript Repositories*. Chicago: Society of American Archivists, 1991.

Appraisal:

*Haas, Joan K., Helen Willa Samuels, and Barbara Trippel Simons. *Appraising the Records of Modern Science and Technology: A Guide*. Cambridge, Mass: MIT, 1985.

*Ham, F. Gerald. *Archival Fundamentals Series: Selecting and Appraising Archives and Manuscripts*. Chicago: Society of American Archivists, 1992.

+Harrison, Helen. *The Archival Appraisal of Sound Recordings and Related Materials: A RAMP Study with Guidelines*. Paris: UNESCO, 1987. Note: The term RAMP refers to UNESCO's long-term Records and Archives Management Programme.

+Kula, Sam. *The Archival Appraisal of Moving Images: A RAMP Study with Guidelines*. Paris: UNESCO, 1983.

+Leary, William H. *The Archival Appraisal of Photographs: A RAMP Study with Guidelines*. Paris: UNESCO, 1985.

+Naugler, Harold. *The Archival Appraisal of Machine-Readable Records: A RAMP Study with Guidelines*. Paris: UNESCO, 1984.

University of Washington Libraries. *Manual for Accessioning, Arrangement, and Description of Manuscripts and Archives*. Seattle: University of Washington Libraries, 1979.

Walden, David. "Stretching the Dollar: Monetary Appraisal of Manuscripts," *Archivaria* 11, Winter 1980-81: pp. 101-113.

Conservation: See Preservation and specific media names such as Photographs, Magnetic Media, Drawings and Prints.

Description:

@Betz, Elisabeth W. *Graphic Materials: Rules for Describing Original Items and Historical Collections*. Washington, DC: Library of Congress, 1982.

^*The Chicago Manual of Style*, 14th ed. Chicago: University of Chicago Press, 1993.

Getty Art History Information Program. Peterson, Toni, ed. *Art and Architecture Thesaurus*. 2nd ed., 5 vols., New York: Oxford University Press, 1990. [Available from Oxford University Press, Attn: Humanities and Social Sciences Marketing, 200 Madison Ave., N.Y., N.Y. 10157-0913.]

Gorman, Michael. *The Concise AACR2, Being a Rewritten and Simplified Version of the Anglo-American Cataloguing Rules*. 2nd ed. Ottawa, Canada: Canadian Library Association, 1981.

^Gorman, Michael and Paul W. Winkler, eds. *Anglo-American Cataloging Rules*. 2nd ed., Chicago: American Library Association, 1978.

*Henson, Steven L. *Archives, Personal Papers, and Manuscripts: A Cataloging Manual for Archival Repositories, Historical Societies, and Manuscript Libraries*. 2nd ed., Chicago: Society of American Archivists, 1989.

Kensworthy, Mary Anne, et al. *Preserving Field Records: Archival Techniques for Archaeologists and Anthropologists*. Philadelphia: The University Museum, University of Pennsylvania, 1985.

@Library of Congress. *Name Authorities Cumulation*. [Annually cumulated Microform and CD-ROM]

@Library of Congress. *Library of Congress Subject Heading List*. (16th ed., 3 vols., prepared by the Office of Subject Cataloging Policy Service, Library of Congress) Washington, DC: Library of Congress, 1993.

*Miller, Frederic M. *Archival Fundamentals Series: Arranging and Describing Archives and Manuscripts*. Chicago: Society of American Archivists, 1990.

@Parker, Elisabeth Betz. *LC Thesaurus for Graphic Materials: Topical Terms for Subject Access*. Washington, DC: Library of Congress, 1987.

*Smiraglia, Richard P. *Describing Archival Materials: The Use of the MARC AMC Format*. New York: Haworth Press, 1990.

*Society of American Archivists, *Describing Archives: A Content Standard (DAC5)*. Chicago, IL: Society of American Archivists, 2007.

@Zinkham, Helena and Elisabeth Betz Parker. *Descriptive Terms for Graphic Materials: Genre and Physical Characteristic Headings*. Washington, DC: Library of Congress, 1986.

Disaster Planning:

*Fortson, Judith. *Disaster Planning and Recovery: A How-to-Do-It Manual for Librarians and Archivists*. New York: Neal-Schuman Publishers, Inc. 1992.

#Smithsonian Institution, National Archives and Records Administration, Library of Congress, and National Park Service. *A Primer on Disaster Preparedness, Management, and Response: Paper-Based Materials*. Selected Reprints. Washington, DC: The National Archives, 1993. [Available free from Preservation Services, NARA, 7th & Pennsylvania Ave NW, Washington DC 20408.]

Drawings, Maps, and Plans:

*Ehrenberg, Ralph, E. *Archives and Manuscripts: Maps and Architectural Drawings*. Chicago: Society of American Archivists, 1982.

Ellis, Margaret H. *The Care of Prints and Drawings*. Nashville, Tenn.: American Association for State and Local History, 1987.

Jivat-Wasiutynski, Thea. "Architectural Drawings and Prints: Materials and Storage," in *Bulletin of the Association of Canadian Archivists* 8 (March 1983): pp. 9-10.

@Library of Congress. *Map Cataloging Manual*. Washington, DC: Library of Congress, 1991.

*Schrock, Nancy Carlson and Mary Campbell Cooper. *Records in Architectural Offices: Suggestions for the Organization, Storage and Conservation of Architectural Office Records*. 3rd, ed., Cambridge, MA: Massachusetts Committee for the Preservation of Architectural Records (MassCOPAR), 1992.

Electronic Records: See Magnetic Media

Ephemera:

Clinton, Alan. *Printed Ephemera: Collection, Organization and Access*. London: Clive Bingley, 1981.

*Makepeace, Chris E. *Ephemera: A Book on its Collection, Conservation, and Use*. Ashgate Publishing Company, 1985.

Organ, Michael. "Ephemera in Archives: What to do?" in *Archives and Manuscripts*, 15/2, November 1987, pp. 105-118.

Ethics: See Legal and Ethical Issues

Legal and Ethical Issues:

Ardito, Stephanie. "The Information Broker and Intellectual Property Rights," in *Bulletin of the American Society for Information Science* 21 (3), pp. 19-20.

Bennett, Scott. "The Copyright Challenge: Strengthening the Public Interest in the Digital Age," in *Library Journal* 119 (19), pp. 34-37.

Branscomb, Anne Wells. "Public and Private Domains of Information: Defining the Legal Boundaries," in *Bulletin of the American Society for Information Science* 21 (2), pp. 14-18.

Branscomb, Anne Wells. *Who Owns Information: From Privacy to Public Access*. New York: Basic Books, 1995.

Brinson, J. Dianne and Mark F. Radcliffe. *MultiMedia Law and Business Handbook: A Practical Guide for Developers and Publishers*. New York: Ladera Press and Quality Books, 1996.

Crawford, Tad. *Business and Legal Forms for Fine Artists*. New York: Allworth Press, 1990.

Feldman, Franklin, and S.E. Weil. *Art Law: Rights and Liabilities of Creators and Collectors*. Boston: Little, Brown and Co., 1988.

Levine, Melissa Smith. "Electronic Publishing: A Legal and Practical Primer," *CRM*, 18 (9), pp. 23-26.

*MacNeil, Heather. *Without Consent: The Ethics of Disclosing Personal Information in Public Archives*. Metuchen, New Jersey: Scarecrow Press, 1992.

%Malaro, Marie C. *A Legal Primer on Managing Museum Collections*. Washington, DC: Smithsonian Institution Press, 1985.

*Peterson, Gary M. and Trudy Huskamp Peterson. *Archives and Manuscripts: Law*. Chicago: Society of American Archivists, 1985.

*Society of American Archivists. *SAA Code of Ethics for Archivists*. Chicago: Society of American Archivists, 1992.

Magnetic Media--Electronic Records:

*Bearman, David, ed. *Archives and Museum Information Technical Report No. 13: Archival Management of Electronic Records*. Pittsburgh, Pa.: Archives and Museum Informatics, 1991.

^Dodd, S.A. *Cataloguing Machine-Readable Data Files: An Interpretive Manual*. Chicago: American Library Association, 1982.

Duranti, Luciana, ed., *The Long-Term Preservation of Authentic Electronic Records: Findings of the InterPARES Project*. N.p.: ArchiLab, ca. 2002.

+Garrel, Katherine. *Conceptual Problems Posed by Electronic Records: A RAMP Study*. Paris: UNESCO, 1990.

*Hedstrom, Margaret L. *Archives and Manuscripts: Machine-Readable Records*. Chicago: Society of American Archivists, 1984.

>Kenney, Anne R. and Lynne K. Personius. *Joint Study in Digital Preservation: Phase I*. Washington, DC: Commission on Preservation and Access, 1992.

*Kowlowitz, Alan. *Archival Informatics Technical Report: Archival Appraisal of Online Information Systems*. Pittsburgh, Pa.: Archives and Museum Informatics, 1988.

Krogh, Peter, *The DAM Book: Digital Asset Management for Photographers*. Cambridge, UK: O'Reilly, 2006.

>Lesk, Michael. *Image Formats for Preservation and Access*. Washington, DC: Commission on Preservation and Access, 1990.

>Lynn, M. Stuart. *Preservation and Access Technology: The Relationship Between Digital and Other Media Conversion Processes*. Washington, DC: Commission on Preservation and Access, 1990.

McLeod, Julie, and Catherine Hare, *Managing Electronic Records*. London, UK: Facet Publishing, 2005.

#National Archives and Records Administration. *Managing Electronic Records, National Archives and Records Administration Instructional Guide Series*, Washington DC: NARA, 1990.

Saffady, William, *Managing Electronic Records*. Lenexa, KS: ARMA International, 2002.

Stephens, David O., and Roderick C. Wallace, *Electronic Records Retention: New Strategies for Data Life Cycle Management*. Lenexa, KS: ARMA International, 2003.

>Van Bogart, Dr. John W.C. *Magnetic Tape Storage and Handling: A Guide for Libraries and Archives*. Washington, DC: The Commission on Preservation and Access, 1995.

Magnetic Media--Sound Recordings:

%Hendriks, Klaus B. "The Preservation and Storage of Sound Recordings," in *Conservation Concerns: A Guide for Collectors and Curators*, ed., Konstanze Bachman, Washington, DC: Smithsonian Institution Press, 1992.

MacKay, Nancy, *Curating Oral Histories: From Interview to Archive*. Walnut Creek, CA: Left Coast Press, 2007.

McWilliams, Jerry. *The Preservation and Restoration of Sound Recordings*. Nashville, Tennessee: American Association for State and Local History, 1979.

*Pickett, A.G., and M.M. Lemcoe. *Preservation and Storage of Sound Recordings*. Washington, DC: Library of Congress, 1959.

*Stielow, Fredrick J. *The Management of Oral History Sound Archives*. New York: Greenwood Publishing Group, 1986.

*Ward, Allan. *A Manual of Sound Archives Administration*. New York: Ashgate Publishing, Co., 1990.

Magnetic Media--Video Recordings:

International Federation of Television Archives (FIAT). *Recommended Standards and Procedures for Selection and Preservation of Television Program Material*. Paris: FIAT, 1981.

Orbanz, Eva, ed., *Archiving the Audio-Visual Heritage: A Joint Symposium*. Berlin: Stiftung Deutsche Kinemathek, 1988.

Motion Picture Film:

Bowser, Eileen and John Kuiper. *A Handbook for Film Archives*. Brussels, Belgium: International Federation of Film Archives (FIAF), 1991.

Harrison, Helen. *Film Library Techniques: Principles of Administration*. New York: Hastings House, 1973.

International Federation of Film Archives. *Problems of Selection in Film Archives: FIAF Symposium Kalovy-Vary 21/6/1980*. Brussels, Belgium: FIAF, 1981.

Sargent, Ralph N. *Preserving the Moving Image*. Corporation for Public Broadcasting and the NEA, 1974.

@White-Henson, Wendy. *Archival Moving Image Materials: A Cataloguing Manual*. Washington, DC: Library of Congress, 1984.

Periodicals--Archives:

The Abbey Newsletter: Bookbinding and Conservation. (ISSN 0276-8291). Abbey Publications, 7105 Geneva Drive, Austin, TX 78723. Tel: 512-929-3992; Fax: 512-929-3995. Issued eight times a year.

The American Archivist (Official Journal of the Society of American Archivists, ISSN 0360-9081) The Society of American Archivists, 600 S. Federal, Suite 504, Chicago, IL 60605. Tel: 312-922-0140; Fax: 312-347-1452. Published quarterly.

Archival Outlook (Official Newsletter of the Society of American Archivists, ISSN 0091-5971) The Society of American Archivists, 600 S. Federal, Suite 504, Chicago, IL 60605. Tel: 312-922-0140; Fax: 312-347-1452. Published six times a year.

Archives and Museum Informatics: Cultural Heritage Information Quarterly (ISSN 1042-1467) published by Archives & Museum Informatics, 5501 Walnut Street, Suite 203, Pittsburgh, PA. 15232-2311. Tel: 412-683-9775; Fax: 412-683-7366. Published Quarterly.

Conservation Administration News: A Quarterly Publication of Library and Archival Preservation. published by The University of Tulsa, McFarlin Library, 600 S. College Avenue, Tulsa, Oklahoma 74104. Tel: 918-631-2864. Published quarterly.

Photography and Photomechanicals:

\$American National Standards Institute (ANSI). *American National Standard for, Photography (Films and Slides)--Black-and-White Photographic Paper Prints--Practice for Storage, ANSI PH1.48--1982 (R 1987)* New York: American National Standards Institute, 1982.

\$_____. *American National Standard for Imaging Media--Practice for Storage of Processed Photographic Plates. ANSI PH.45-1981 (R 1989)*. New York: American National Standards Institute, 1981.

\$_____. *American National Standard for Photography (Film)--Storage of Processed Safety Film. ANSI PH1.43-1985*. New York: American National Standards Institute, 1985.

\$_____. *American National Standard for Photography (Processing)--Photographic Processed Films, Plates, and Papers--Filing Enclosures and Containers for Storage. ANSI IT9.21991*. New York: American National Standards Institute, 1991.

Coe, Brian, and Mark Haworth-Booth. *A Guide to Early Photographic Processes*. London: Victoria and Albert Museum, 1983.

Eastman-Kodak. *Conservation of Photographs*. Rochester, NY: Kodak Publication F-40, Rochester, NY: Eastman Kodak Company, 1985.

+Hendriks, Klaus B. *The Preservation and Restoration of Photographic Materials in Archives and Libraries: A RAMP Study with Guidelines*. PGI-84/WS/1, Paris: UNESCO, 1984.

Hendriks, Klaus B. "The Stability and Preservation of Recorded Images." In *Imaging Processes and Materials. Nebbles's 8th edition*. New York: Van Nostrand Reinhold, 1989.

International Federation of Library Associations and Institutions. *IFLA Preservation Packet on the Care, Handling and Storage of Photographs*. Washington, DC: IFLA, 1993.

Krogh, Peter, *The DAM Book: Digital Asset Management for Photographers*. Cambridge, UK: O'Reilly, 2006.

Northeast Document Conservation Center *Technical Leaflet* "Storage and Handling: Storage Enclosures for Photographic Materials." Andover, MA: NEDCC, n.d.

*Reilly, James M. *Care and Identification of 19th Century Photographic Prints*. Kodak Publication G-2S. Rochester, New York: Eastman Kodak Co., 1986.

*Ritzenthaler, Mary Lynn, Gerald J. Munoff, and Margery S. Long. *Archives and Manuscripts: Administration of Photographic Collections*. SAA Basic Manual Series. Chicago: Society of American Archivists, 1984.

*Ritzenthaler, Mary Lynn, and Diane Vogt-O'Connor, *Photographs: Archival Care and Management*. Chicago, IL: Society of American Archivists, 2006.

Preservation--General:

*Appelbaum, Barbara. *Guide to Environmental Protection of Collections*. Sound View Press, 1991.

%Bachmann, Konstanze, ed. *Conservation Concerns: A Guide for Collectors and Curators*. Washington, DC: Smithsonian Institution Press, 1992.

Canadian Conservation Institute. *CCI Notes*. (Technical Leaflets). Ottawa: Canadian Conservation Institute, 1993.

A Conservation Assessment: A Tool for Planning, Implementing, and Fundraising. Marina del Rey, California: Getty Conservation Institute and National Institute for the Conservation of Cultural Property, 1990.

**Guide and Resources for Archival Strategic Planning (GRASP)*. Washington, DC: NAGARA, 1990. (Available from SAA).

Curtin, Bonnie Rose. *NAGARA (National Association of Government Archives and Records Administrators) GRASP Guide to Resources for Archival Strategic Preservation Planning*. Atlanta, GA: NAGARA, 1990.

National Park Service. *Museum Handbook, Part I*, 1990.

*National Research Council. *Preservation of Historical Records*. New York: National Academy Press, 1986.

Ogden, Sherelyn, ed. for the Northeast Document Conservation Center. *Preservation of Library and Archival Materials*. Andover, MA: NEDCC, 1992.

*Paris, Jan. *Choosing and Working with a Conservator*. SOLINET, 1990.

>Reilly, James J., Douglas W. Nishimura, and Edward Zinn. *New Tools for Preservation: Assessing Long-Term Environmental Effects on Library and Archives Collections*. Washington, DC: Commission on Preservation and Access, 1995.

Ritzenthaler, Mary Lynn. "Preservation of Archival Records: Holdings Maintenance at the National Archives," *National Archives Technical Information Paper No. 6*. Washington, DC: National Archives and Records Administration, 1990.

*Ritzenthaler, Mary Lynn. *Archival Fundamentals Series: Preserving Archives and Manuscripts*. Chicago: Society of American Archivists, 1993.

Preservation--Cellulose Nitrate and Diacetate Photographic Management: [See also Reformatting.]

- Canadian Conservation Institute. "Care of Black-and-White Photographic Negatives on Film," *Canadian Conservation Institute Notes*, 16/3.
- National Fire Protection Association. "Standard for the Storage and Handling of Cellulose Nitrate Motion Picture Film," *NFPA 40-1982*. New York: NFPA, n.d.
- National Park Service. *Museum Handbook, Part I*, Appendix M, 1990.
- Puglia, Steven. *A Short Guide to Nitrate Negatives: History, Care, and Duplication*, Andover, MA: Northeast Document Conservation Center, 1986.
- Young, Christine. "Nitrate Films in the Public Institution," *AASLH Technical Leaflet*. Nashville, TN: AASLH, n.d.

Preservation--Mold Management:

- National Park Service. *Conserve O Gram 3/4* "Mold and Mildew: Prevention of Microorganism Growth in Museum Collections."
- Northeast Document Conservation Center. "Drying Wet Books and Records," *NEDCC Technical Leaflet on Emergency Management*, Andover, MA: NEDCC, 1992.
- Nyberg, Sandra. "The Invasion of the Giant Spore," *SOLINET Preservation Program Leaflet No. 5*, SOLINET, 1987.
- Price, Lois. "The Spore Invades and Begins to Grow. Now What?" in *Conservation Center for Art and Historic Artifacts reprint*, Philadelphia, PA: CCAHA, 1991.
- Waters, Peter. "Procedures for Salvage of Water-Damaged Library Materials," in *A Primer on Disaster Preparedness, Management, and Response: Paper-Based Materials*. Washington, DC: Library of Congress, 1993.

Records Management:

- National Archives and Records Administration. *Disposition of Federal Records*. Washington, DC: NARA, Washington, DC: NARA, 1992.
- National Park Service. *NPS-19, Records Management Guideline*. Washington, DC: National Park Service, revised 1995.
- *Penn, Ira. A. Morddel, G. Pennix, and K. Smith. *Records Management Handbook*. New York: Ashgate Publishing, 1989.
- Skupsky, Donald S. *Recordkeeping Requirements*. New York: Information Requirements Clearinghouse, 1988.

Reformatting:

- \$American National Standards Institute. New York, NY (See following list of standards)
- ANSI/NAPM IT9.1-1992 (Silver Gelatin Imaging Stability)
 - ANSI IT9.2-1991 (Enclosures and Containers)
 - ANSI IT9.5-1992 (Diazo Microforms Stability)
 - ANSI IT9.6-1991 (Safety Film Stability)
 - ANSI IT9.11-1991 (Safety Film Storage)
 - ANSI/NAPM IT9.11-1993 (Storage of Photographic Film)

ANSI IT9.20-1994 (Storage of Photographic Prints)
ANSI/NAPM IT9.18-1994 (Storage of Photographic Plates)
ANSI IT9.12-1991 (Vesicular Microform Stability)
ANSI/AIIM MS5-1992 (Microfiche)
ANSI/AIIM MS14-1988 (16mm and 35mm Roll Microfilm)
ANSI/AIIM MS34-1990 (Roll Microfilm Reels)
ANSI/AIIM MS51-1991 (Micrographics Resolution)
ANSI PH1.51-1990 (Photo and Micrographic Film Dimensions)
ANSI/ASC OG4.8-1985 (Residual Thiosulfate)
ANSI/AIIM MS19-1987 (Microform Identification)
ANSI/AIIM MS23-1991 (Roll Microfilm Inspection)
ANSI/AIIM MS43-1988 (Copy Microform Inspection)
ANSI/AIIM MS45-1990 (Microform Inspection for Deterioration)
ANSI/AIIM MS48-1990 (How to Microfilm Public Records)
ANSI/AIIM MS111-1992 (How to Microfilm Newspapers)

Association for Information and Image Management. *Practice for Operational Procedures/Inspection and Quality Control of First-Generation, Silver-Gelatin Microfilm of Documents*, Silver Spring, MD: ANSI/AIIM MS23-1983. Silver Spring, MD: AIIM, 1983.

Elkington, Nancy, ed. *RLG Archives Microfilming Manual*. Mountain View, CA: Research Libraries Group, 1994.

*Gwinn, Nancy E. *Preservation Microfilming: A Guide for Librarians and Archivists*. Chicago: American Library Association, 1987.

Hendriks, Klaus, B., Douglas R. Madeley, Fred Toll and Brian Thurgood. "The Duplication of Historical Black-and-White Negatives," *Journal of Imaging Technology* 12, no.4 (1986), pp. 185-199.

National Archives and Records Administration. *Optical Digital Image Storage System (ODISS)*. Washington, DC: NARA and AIIM, 1993.

National Park Service. *Conserve O Gram* 19/4 "Archives: Preservation Through Photocopying."

Northeast Document Conservation Center. "Reformatting: Optical Disks and Preservation Issues: Select Bibliography," *NEDCC Technical Leaflet*. Andover, MA: NEDCC, n.d.

Northeast Document Conservation Center. "Reformatting: Microfilm and Microfiche," *NEDCC Technical Leaflet*. Andover, MA: NEDCC, n.d.

#Puglia, Steven T. "Negative Duplication: Evaluating the Reproduction and Preservation Needs of Collections," *National Archives and Records Administration reprint*. Washington, DC: NARA, n.d.

Northeast Document Conservation Center. "Reformatting: Microfilm and Microfiche," *NEDCC Technical Leaflet*. Andover, MA: NEDCC, 1992.

CC. List Of Figures

Figure D.1	Archival and Manuscript Collections Survey Form	D:113
Figure D.2a	Example of an Archival Collection That is Out of Order	D:114
Figure D.2b	Unarranged Materials from D.2a Restored to Original Order	D:114
Figure D.3a	Sample Hierarchy—Organizational Archives	D:115
Figure D.3b	Sample Hierarchy—Personal Papers	D:116
Figure D.4a-g	Sample Hierarchies/Filing Schemes for Associated Records	D:117
Figure D.5	Archives and Manuscript Collection Separation Sheet.....	D:125
Figure D.6	Sample Finding Aid.....	D:126
Figure D.7	Freedom of Information Act.....	D:143
Figure D.8	Researcher Registration Form	D:153
Figure D.9	Copyright and Privacy Restrictions Form	D:154
Figure D.10	Access Policies and Rules Governing Use Form.....	D:155
Figure D.11	Researcher Duplication Form	D:157

Archival and Manuscript Collections Survey Form

COLLECTION TITLE (Creator/Format/Alternate Names/Accession/Catalog #s):

DATES (Inclusive & Bulk):

PROVENANCE (Creator/Function/Ownership & Usage history/Related collections/Language):

PHYSICAL DESCRIPTION (Linear feet/Item count/Document Processes/Formats/Genres):

SUBJECTS (Personal, Group, Taxonomic, and Place Names/Eras/Activities/Events/
Objects/Structures/Genres):

ARRANGEMENT (Series/Principle of Arrangement/Finding Aid):

RESTRICTIONS (Check and Describe) Donor _____ Privacy/Publicity _____ Copyright _____
Label _____ No Release Forms _____ Archeological, Cave, or Well Site _____ Endangered Species
Site _____ Sensitive _____ Classified _____ Fragile _____ Health Hazard _____ Other _____

LOCATIONS Building(s), Room(s), Wall(s), Shelf Unit(s), Position(s), Box(es):

EVALUATION (Check and Describe Status) Official Records __ Non-Official Records __ Fits Park
SOCS __ Outside SOCS __ (Rate Collection Value: 1=Low; 3= Average; 6= High) Informational __
Artifactual __ Associational __ Evidential __ Administrative __ Monetary __

CONDITION (Check and Describe) Excellent _____ Good _____ Fair _____ Poor _____ Mold _____
Rodents _____ Insects _____ Nitrate _____ Asbestos _____
Water Damage _____ Other _____

OTHER (Please Describe)

Figure D.1 Archival and Manuscript Collections Survey Form (Sample) [Optional]

UNARRANGED RECORDS

- a. Financial Ledger, Vol. C
- b. Correspondence File, May-July 1910
- c. Financial Ledger, Vol. A
- d. Financial Ledger, Vol. B
- e. Diary, 1909
- f. Correspondence File, February-April 1910
- g. Diary 1912
- h. Financial Ledger, Vol. E
- i. Box of Cancelled Checks, 1911
- j. Diary, 1907
- k. Diary, 1908
- l. Correspondence File, August-October 1910
- m. Correspondence File, November 1909-January 1910
- n. Financial Ledger, Vol. D
- o. Diary, 1906
- p. Correspondence File, November 1910-January 1911
- q. Box of Cancelled Checks, 1910
- r. Correspondence File, August-October 1909
- s. Diary, 1911

Figure D.2a. Example of an Archival Collection That is Out of Order

**HIERARCHY, AFTER
REESTABLISHING ORIGINAL ORDER**

SERIES I: CORRESPONDENCE, August 1909 to January 1911, with gaps
(arranged chronologically)

SERIES II: FINANCIAL LEDGERS
(arranged alphabetically by volume)

SERIES III: DIARIES, 1906-1912, with gaps
(arranged chronologically)

SERIES IV: CANCELLED CHECKS, 1910-1911
(arranged chronologically)

Figure D.2b. Unarranged Materials from D.2a Restored to Original Order

RECORDS OF THE XYZ CORPORATION

SERIES I: RECORDS OF THE PRESIDENT'S OFFICE

SUBSERIES I: Correspondence (arranged alphabetically by correspondent, and thereunder chronologically)

SUBSERIES 2: Policy Directives (arranged by year, and thereunder numerically)

SUBSERIES 3: Speech Files (arranged chronologically)

SERIES II: RECORDS OF THE MANUFACTURING DIVISION

SUBSERIES 1: Correspondence

 SUB-SUBSERIES A: Incoming Correspondence (arranged alphabetically by correspondent)

 SUB-SUBSERIES B: Outgoing Correspondence (arranged chronologically)

SUBSERIES 2: Production Records (arranged by department, and thereunder by shift)

SUBSERIES 3: Supply Records (arranged alphabetically by vendor)

SERIES III: ADMINISTRATION DIVISION

SUBSERIES 1: Personnel Records

 SUB-SUBSERIES A: Employee Files (arranged alphabetically by name of employee)

 SUB-SUBSERIES B: Correspondence (arranged alphabetically by name of correspondent)

SUBSERIES 2: Sales Records

 SUB-SUBSERIES A: Sales Agents' Reports (arranged chronologically, and thereunder alphabetically by name of sales agent)

 SUB-SUBSERIES B: Advertising Files (arranged by media type, and thereunder by market)

SUBSERIES 3: Research and Development Records (arranged by project number)

SUBSERIES 4: Accounting Records

 SUB-SUBSERIES A: Ledgers (arranged by volume number)

 SUB-SUBSERIES B: Financial Reports (arranged by fiscal year)

Figure D.3a Sample Hierarchy for a Collection of Organizational Archives

FRED SMITH PAPERS

SERIES I: CORRESPONDENCE (arranged alphabetically by name of correspondent,
and thereunder chronologically)

SERIES II: DIARIES (arranged by year)

SERIES III: RESEARCH FILES (arranged alphabetically by subject)

SERIES IV: FINANCIAL RECORDS

SUBSERIES I: Bank Statements (arranged alphabetically by bank, and thereunder chronologically)

SUBSERIES 2: Canceled Checks (arranged alphabetically by bank, and thereunder numerically)

SERIES V: STILL PICTURES

SUBSERIES 1: Albums (unarranged)

SUBSERIES 2: Prints (arranged alphabetically by subject)

SUBSERIES 3: Negatives (arranged numerically)

SERIES VI: SOUND RECORDINGS (arranged by type, and thereunder chronologically)

Figure D.3 b Sample Hierarchy for a Collection of Personal Papers

SAMPLE HIERARCHIES/FILING SCHEMES
FOR ASSOCIATED RECORDS

Most parks make or receive records relating to cultural history or natural history projects that occur in the park and recover objects or specimens that are accessioned into the park's museum collection. These are called "associated records."

These records are park records, regardless of whether they were actually produced by park staff, other NPS staff, contractors, or outside researchers working under park research permits. **Records for a particular project do not represent a stand-alone collection.** Project files should not be cataloged individually as separate collections, but should be managed as file units within larger collections.

Note: Even though project files should not be cataloged as separate collections, they may still be described individually at the File Unit Level in the Archives Module.

Note: Even though project files should be managed as part of larger collections, individual files may still be co-located at partner repositories with their associated objects. For files that are co-located, complete an outgoing loan agreement and indicate in the location field of the File Unit Level screen that the file is housed off site.

Associated records for a given discipline may be handled either as a collection or as a series within a larger collection encompassing all of the park's resource management records. Within the collection or series, however, parks will have to identify appropriate hierarchies and filing schemes based on particular circumstances. **Figures D.4b-D.4g** provide sample hierarchies and filing schemes that may be adopted.

There are only a few absolutes among the proposed hierarchical structures:

1. Associated records for any given project should be handled as project files—not as collections or series. Those files should be arranged within a single series or a single collection according to a uniform filing scheme. The recommended format would be to use accession numbers as file numbers, but the park may develop its own file designations.
2. If a park accessions associated records generated by its own staff or contractors, by the regional center, or by permitted researchers, it may create separate series reflecting this (as is shown in Figures D.4c and D.4d).
3. If a park accessions associated records produced exclusively in the park, as well as records produced through multi-park permits, it may create separate series reflecting this (as is shown in Figure D.4e).

Beyond these basics, parks will have to improvise and develop hierarchies based on what kinds of records are actually present. For example:

1. Suppose a park implements the hierarchy in Figure D.4c, to the extent of having one series for park-generated records and one series for center-generated records. There is no need for the park series to maintain the same subseries structure as the center series. The park series may be broken out into subseries and sub-subseries, but the series of center records may have nothing more than a simple file unit organization (as is shown in Figure D.4a).
2. Associated records accessioned by a park may fall into a series structure completely different from the "Reports Notes and Correspondence; Still Pictures; Maps" organization used in some of the samples. There may be additional series or subseries, fewer series or subseries, or completely different series or subseries. There is no universal template.

Figure D.4a Sample Hierarchies/Filing Schemes for Associated Records

SIMPLE FILE UNIT ARRANGEMENT

It is possible that a collection of associated records would be made up of file units that are not organized into series. This is the most basic hierarchy there is:

Local Coll. No. 5001: Records Associated with Archeological Projects at XYZ National Park

File Units no. 001 to ?: Individual file units, arranged numerically by accession number (or by any other arrangement scheme the park chooses).

Figure D.4b Simple File Unit Arrangement

BASIC SERIES ORGANIZATION

The series organization outlined below is just a suggestion. An actual series organization could take different forms, depending on the actual records and how they are maintained. Within this proposed structure, all of the park's projects files for a particular discipline are handled as a collection and are organized into series by physical type. Thereunder, the documentation on each project is kept intact, and should be described individually in separate File Unit Level screens in the Archives Module. In other words, the records are managed by project, but within a hierarchical structure.

Local Coll. No. 5002: Records Associated with Archeological Projects at ABC National Park

Series I: Reports, Notes, and Correspondence

File Units 001 to ?: Individual file units, arranged numerically by accession number.

Series II: Still Pictures

Subseries A: Prints:

File Units 001 to ?: Arranged by accession number.

Subseries B: Negatives

File Units 001 to ?: Arranged by accession number.

Subseries C: Slides

File Units 001 to ?: Arranged by accession number.

Series III: Maps

File Units 001 to ?: Arranged by accession number.

Figure D.4c Basic Series Organization

SEPARATE SERIES FOR PARK-GENERATED ACCESSIONS AND CENTER-GENERATED COLLECTIONS

In some cases, associated records may be managed partly at a center and partly at a park—but all of the materials, of course, remain park property. Since parks manage the assignment of accession numbers, it should be possible to coordinate between the parks and the centers using the park accession numbers, and thus maintain a single arrangement scheme for everything (regardless of location). That is, Accessions 00123 through 00129 could be at the park, Accessions 00130-00140 at the center, Accession 00141 at the park, and so forth. This could be reflected in that same order within a single run of file unit numbers in the Archives Module.

If it proves too difficult for parks and centers to keep track of accessions in this way, then collections could be organized into series based on whether park staff or park contractors carried out a project, or whether center staff or center contractors carried out a project. Assuming that both park-generated and center-generated records are organized in the same fashion as the materials in **Figure 4.c**, a collection divided into park- and center-generated archives would look like this:

Local Coll. No. 5003: Records Associated with Archeological Projects at XYZ National Park

Series I: Regional Center Projects

- Subseries A: Reports, Notes, and Correspondence
 - File Units 001 to ?: Individual file units, arranged by accession number
- Subseries B: Still Pictures
 - Sub-subseries 1: Prints (arranged by accession number)
 - Sub-subseries 2: Negatives (arranged by accession number)
 - Sub-subseries 3: Slides (arranged by accession number)
- Subseries C: Maps (arranged by accession number)

Series II: Park Projects

- Subseries A: Reports, Notes, and Correspondence
 - File Units 001 to ?: Individual file units, arranged by accession number
- Subseries B: Still Pictures
 - Sub-subseries 1: Prints (arranged by accession number)
 - Sub-subseries 2: Negatives (arranged by accession number)
 - Sub-subseries 3: Slides (arranged by accession number)
- Subseries C: Maps (arranged by accession number)

REMEMBER: Within this hierarchical structure, project files may still be described individually—but at the File Unit Level of the Archives Module, not as separate catalog records.

NOTE: The proposed series/subseries/sub-subseries structure is just an example of how a collection broken up into Regional Center projects and Park projects would work; it is not meant to be an immutable template. Also, because the breakdown would be based on park- or center-generated records (as opposed to managed), the hierarchy would not have to change if records were sent from the park to the center, or from the center to the park.

Figure D.4d Separate Series for Park-Generated Accessions and Center-Generated Collections

SEPARATE SERIES FOR PARK-GENERATED, CENTER-GENERATED, AND PERMITTED PROJECTS

It should be possible to use the park-assigned accession numbers to keep all associated records for a given discipline in serial order in the Archives Module. However, the fact that associated records for permitted research not always arrive in a timely fashion may complicate the coordination process. Just as parks might divide collections into series according to whether the work was done by center staff/contractors or park staff/contractors, they might also maintain a separate series for associated records generated through the permit process. It may be necessary to use placeholders to reserve space and maintain proper sequencing in the Archives Module if parks assign accession numbers before receiving records. The sample hierarchy below would be for a park that has assigned accession numbers to park, center, and permitted projects alike, and finds it easier to file/track them separately:

Local Coll. No. 5004: Records Associated with Archeological Projects at ABC National Park

Series I: Regional Center Projects

- Subseries A: Reports, Notes, and Correspondence
 - File Units 001 to ?: Individual file units, arranged by accession number
- Subseries B: Still Pictures
 - Sub-subseries 1: Prints (arranged by accession number)
 - Sub-subseries 2: Negatives (arranged by accession number)
 - Sub-subseries 3: Slides (arranged by accession number)
- Subseries C: Maps (arranged by accession number)

Series II: Park Projects

- Subseries A: Reports, Notes, and Correspondence
 - File Units 001 to ?: Individual file units, arranged by accession number
- Subseries B: Still Pictures
 - Sub-subseries 1: Prints (arranged by accession number)
 - Sub-subseries 2: Negatives (arranged by accession number)
 - Sub-subseries 3: Slides (arranged by accession number)
- Subseries C: Maps (arranged by accession number)

Series III: Permitted Research Projects

- Subseries A: Reports, Notes, and Correspondence
 - File Units 001 to ?: Individual file units, arranged by accession number
- Subseries B: Still Pictures
 - Sub-subseries 1: Prints (arranged by accession number)
 - Sub-subseries 2: Negatives (arranged by accession number)
 - Sub-subseries 3: Slides (arranged by accession number)
- Subseries C: Maps (arranged by accession number)

Figure D.4e Separate Series for Park-Generated, Center-Generated, and Permitted Projects

SEPARATE SERIES FOR RECORDS GENERATED VIA MULTI-PARK PERMITS

Many natural history projects in NPS now involve multiple parks. In such cases, each park involved in a multi-park permitted project would get a copy of the final report, but the lead park would receive a full set of the project's records. Thus, a single park may have biological project files relating just to that park itself. A lead park could have records generated by one or more multi-park projects, involving numerous parks. To avoid confusion over park-only projects and multi-park projects, natural history collections could follow a hierarchy such as this:

Local Coll. No. 5005: Records Associated with Biological Projects at XYZ National Park

Series I: Park Projects

Subseries A: Reports, Notes, and Correspondence

File Units 001 to ?: Individual file units, arranged by accession number

Subseries B: Still Pictures

Sub-subseries 1: Prints (arranged by accession number)

Sub-subseries 2: Negatives (arranged by accession number)

Sub-subseries 3: Slides (arranged by accession number)

Subseries C: Maps (arranged by accession number)

Series II: Multi-Park Projects

Subseries A: Reports, Notes, and Correspondence

File Units 001 to ?: Individual file units, arranged by accession number

Subseries B: Still Pictures

Sub-subseries 1: Prints (arranged by accession number)

Sub-subseries 2: Negatives (arranged by accession number)

Sub-subseries 3: Slides (arranged by accession number)

Subseries C: Maps (arranged by accession number)

NOTE: These series structures are just suggestions. Actual organizational schemes would depend on what records are actually present and how they are actually arranged. Still, the basic division into series by Park Projects and Multi-Park Projects would be retained.

Figure D.4f Separate Series for Records Generated Via Multi-Park Permits

ASSOCIATED RECORDS FOR A GIVEN DISCIPLINE AS A SERIES WITHIN THE PARK'S COLLECTION OF RESOURCE MANAGEMENT RECORDS

Records associated with archeology projects at a particular park can be handled as a series within the Resource Management collection. Using the complex organizational scheme outlined in **Figure D.4d**, here is how a series of archeological records would fit into the hierarchy for a park's Resource Management Records:

Local Coll. No. 5006: Resource Management Records at ABC National Park

Series I: Land Records

- Subseries A: General Records
- Subseries B: General Grazing Files
- Subseries C: Family Grazing Allotment Records

Series II: Records Relating to Fires and Fire Management

- Subseries A: General Records
- Subseries B: Records Relating to Fires
- Subseries C: Fire Effects Studies

Series III: Construction and Maintenance Records

- Subseries A: Roads and Trails
- Subseries B: Buildings
- Subseries C: Grounds
- Subseries D: Water and Sewer
- Subseries E: Signs, Markers, and Memorials

Series IV: Records Associated with Archeological Projects

Subseries A: Regional Center Projects

- Sub-subseries 1: Reports, Notes, and Correspondence
 - File Units 001 to ?: Individual file units, arranged by accession number
- Sub-subseries 2: Still Pictures
 - Sub-sub-subseries a: Prints (arranged by accession number)
 - Sub-sub-subseries b: Negatives (arranged by accession number)
 - Sub-sub-subseries c: Slides (arranged by accession number)
- Sub-subseries 3: Maps (arranged by accession number)

Subseries B: Park Projects

- Sub-subseries 1: Reports, Notes, and Correspondence
 - File Units 001 to ?: Individual file units, arranged by accession number
- Sub-subseries 2: Still Pictures
 - Sub-sub-subseries a: Prints (arranged by accession number)
 - Sub-sub-subseries b: Negatives (arranged by accession number)
 - Sub-sub-subseries c: Slides (arranged by accession number)
- Sub-subseries 3: Maps (arranged by accession number)

Figure D.4g Associated Records for a Given Discipline as a Series Within the Park's Collection of Resource Management Records

Subseries C: Permitted Research Projects

Sub-subseries 1: Reports, Notes, and Correspondence

File Units 001 to ?: Individual file units, arranged by accession number

Sub-subseries 2: Still Pictures

Sub-sub-subseries a: Prints (arranged by accession number)

Sub-sub-subseries b: Negatives (arranged by accession number)

Sub-sub-subseries c: Slides (arranged by accession number)

Sub-subseries 3: Maps (arranged by accession number)

Figure D.4g continued

Archives and Manuscript Collections Separation Sheet

Document Type (map, newspaper clipping, photograph, etc.) Catalog/Accession Numbers

Document Description (Include collection name; dates; group organizational, personal, and place names; and topics [who, what, where, why, when, and how], etc.)

Item Originally Filed (Collection identifier: specific location, box #, folder #, drawer #, sequence in unit, etc.)

Item Now Filed (Specific location: room #, shelf #, box #, folder #, drawer #, sequence in unit, etc.)

Separated By:

Separation Date:

Figure D.5 Separation Sheet (Form 10-645) [Optional]



FINDING AID

***RECORDS ASSOCIATED WITH ARCHEOLOGICAL PROJECTS
AT ANDERSONVILLE NHS
1970-1997***

**SAMPLE FINDING AID
DO NOT USE FOR REQUESTING RECORDS**

National Park Service

Catalog Number: ANDE 9804

Figure D.6 Sample Finding Aid

TABLE OF CONTENTS

Copyright and Restrictions.....	D:104
History.....	D:105
Scope and Content	D:107
Hierarchy	D:108
Series Descriptions	D:109
File Unit Descriptions	D:110
Container List	D:114

COPYRIGHT AND RESTRICTIONS

The copyright law of the United States (Title 17, United States Code) governs the making of photocopies or other reproductions of copyrighted materials. The various state privacy acts govern the use of materials that document private individuals, groups, and corporations.

Under certain conditions specified in the law, libraries and archives are authorized to furnish a reproduction if the document does not infringe the privacy rights of an individual, group, or corporation. These specified conditions of authorized use include:

- non-commercial and non-profit study, scholarship, or research, or teaching
- criticism, commentary, or news reporting
- as a NPS preservation or security copy
- as a research copy for deposit in another institution

If a user later uses a copy or reproduction for purposes in excess of "fair use," the user may be personally liable for copyright, privacy, or publicity infringement. This institution's permission to obtain a photographic, xerographic, digital, or other copy of a document doesn't indicate permission to publish, exhibit, perform, reproduce, sell, distribute, or prepare derivative works from this document without first obtaining permission from the copyright holder and from any private individual, group, or corporation shown or otherwise recorded.

Permission to publish, exhibit, perform, reproduce, prepare derivative works from, sell, or otherwise distribute the item must be obtained by the user separately in writing from the holder of the original copyright (or if the creator is dead from his/her heirs) as well as from any individual(s), groups, or corporations whose name, image, recorded words, or private information (e.g., employment information) may be reproduced in the source material. The holder of the original copyright isn't necessarily the National Park Service. The National Park Service is not legally liable for copyright, privacy, or publicity infringement when materials are wrongfully used after being provided to researchers for "fair use."

This institution reserves the right to refuse to accept a copying order if fulfillment of the order is judged in violation of copyright or federal or state privacy or publicity law.

HISTORY

Andersonville National Historic Site, located 10 miles northeast of Americus, in southwest Georgia, was established as a unit of the National Park Service on October 16, 1970, under Public Law 91-465. Its mission, as specified in the enabling legislation, is to "provide an understanding of the Civil War prisoner of war story, to interpret the role of prisoner of war camps in history, and to commemorate the sacrifice of Americans who lost their lives in such camps."

Included within the boundaries of the 515-acre park is the former site of Andersonville Prison, which was the most notorious prisoner of war camp during the American Civil War. Known officially during the Civil War as Camp Sumter, it was one of the Confederate Government's largest military prisons. Operating for 14 months in 1864 and 1865, Andersonville held more than 45,000 Union prisoners-of-war -- nearly 13,000 of whom perished because of disease, starvation, overcrowding, poor sanitation, or exposure. The harsh conditions at Andersonville -- while scarcely more severe than other prisoner of war camps operated by the Union and Confederacy alike -- excited such outrage after the war that its superintendent, Captain Henry Wirz, was court-martialed by the United States Army. Wirz was found guilty of war crimes, and executed in November 1865.

In addition to the prison camp, the park also includes the prison camp's burial ground (which was designated as a National Cemetery in July 1865, and which continues to inter the remains of deceased veterans), as well as the site of the camp hospital, the adjacent Confederate fort, and a National Park Service visitors center. Since 1998, the National Park Service has also maintained the National Prisoner of War Museum at Andersonville NHS; this museum tells the story of American prisoners of war throughout the Nation's history, starting with the Revolutionary War.

Archeological projects at Andersonville National Historic Site serve several academic, interpretive, and administrative purposes. They identify the existence of archeological resources, to help ensure their preservation and to prevent construction or other activity from damaging them. They provide data to help the park comply with Section 106 of the National Historical Preservation Act of 1966, which requires Federal agencies to consider the impact of their activities on historic places. They provide information on historic configurations of the prison camp, the fort, and the hospital, that can be used in interpretation and reconstructions. And they can yield artifacts that are accessioned into the park's museum collection and may be used for exhibits and research.

These archeological projects, therefore, add to the body of scholarship on Andersonville, for use by other archeologists, historians, teachers, students, and others. In addition, they contribute to a clearer understanding of the prison camp's history, and enhance the experience of those who visit the park. And they facilitate proper management of archeological resources, in order to minimize any impairment and to promote their preservation for future generations.

Notable projects include a series of studies conducted by the NPS Southeast Archeological Center between 1987 and 1990 to determine the nature, construction techniques, and location of the prison's stockade walls and gates, and to document prison conditions. The park used the findings of these studies to develop new or improved exhibits for the benefit of visitors, and to reconstruct a portion of the stockade walls.

SCOPE AND CONTENT

RECORDS ASSOCIATED WITH ARCHEOLOGICAL PROJECTS AT
ANDERSONVILLE NHS
1970-1997

CATALOG NUMBER ANDE 9804

VOLUME 12 LF

DESCRIPTION Field notes, reports, correspondence, photographs, and maps relating to archeological projects carried out at Andersonville National Historic Site. Included are records produced by non-NPS archeologists conducting permitted research and submitted to the park under the terms of the permit, as well as records produced by NPS archeologists working on official projects. Most records are associated with accessioned objects. Records and objects associated with a single project will have the same park accession number.

ORGANIZATION Organized into 3 series: Series I, Reports, Notes, and Correspondence; Series II, Still Pictures; Series III, Maps.

PROVENANCE

RESTRICTIONS NO

ASSOCIATED

MATERIALS

HIERARCHY

I. SERIES I: REPORTS, NOTES, AND CORRESPONDENCE

II. SERIES II: STILL PICTURES

III. SERIES III: MAPS

SERIES DESCRIPTIONS

I. SERIES I: REPORTS, NOTES, AND CORRESPONDENCE, 1970-1997 (bulk dates: 1970-1997)

Arranged numerically, with file numbers corresponding to park accession numbers, and thereunder arranged by subject.

Correspondence, final reports, draft reports, progress reports, trip reports, field notes, inventories, worksheets, photo logs, specimen logs, budgets, contracts, artifact analysis forms, stratigraphic profiles, and other papers relating to archeological projects at Andersonville NHS. Included are project files on surveys and tests prior to proposed construction activities, 106 compliance surveys, archeological monitoring, test excavations, and investigations of various locations throughout the park.

II. SERIES II: STILL PICTURES, 1970-1997 (bulk dates: 1970-1997)

Arranged by type (negatives, prints, slides), and thereunder by park accession number.

Black & white and color negatives, prints, and slides, relating to excavations, surveys, and other archeological projects at Andersonville NHS.

III. SERIES III: MAPS, 1970-1997 (bulk dates: 1970-1997)

Arranged by park accession number.

Maps, topographic maps, base maps, sketch maps, field maps, site plans, feature plans, grids, drawings, and tables showing artifact distribution by unit and level, relating to archeological surveys, excavations, and investigations at Andersonville NHS.

FILE UNIT DESCRIPTIONS

SERIES I: REPORTS, NOTES, AND CORRESPONDENCE

0001. ANDE 00062: SURVEY AND TESTING, 1977-1990

Cultural Resources inventory, conducted between January and June 1978, to locate and identify archeological features associated with Andersonville Prison and prehistoric sites on ANDE property. Survey carried out preparatory to proposed improvements to maintenance facilities and visitor support facilities outlined in General Management Plan, and other proposed development outlined in the Development Concept plan. Areas tested: Aboriginal site, Inner Stockade, North Gate, Middle Stockade, South Gate, Shed Hospital, Bake House, and development areas. Principal investigator: Ellen Ehrenhard, SEAC.

0002. ANDE 00166: SOIL RESISTIVITY STUDY OF THE HOSPITAL SITE, 1985-1992

Soil resistivity survey conducted at the Hospital Site by Rochelle Marrinan (Florida State University) and Kenneth S. Wild, Jr. (SEAC), July 1985.

0003. ANDE 00276: INVESTIGATIONS OF NORTHEAST CORNER FOR RECONSTRUCTION OF STOCKADE AND DEADLINE (WALKER 1987), 1986-1992

Archeological investigations of the Northeast Corner of the Stockade and Deadline, to determine the impact of reconstruction on the Stockade, conducted by John W. Walker of SEAC.

0004. ANDE 00322: INVESTIGATIONS OF NORTH GATE, 1989-1991

Archeological investigations of North Gate area, conducted in May-June 1989 by Guy Prentice, SEAC.

0005. ANDE 00355: INVESTIGATION OF SOUTHEAST CORNER OF THE INNER STOCKADE, 1990

Archeological investigation of Southeast Corner of the Inner Stockade, conducted by Guy Prentice (SEAC). The study located the Southeast Corner and an escape tunnel, and investigated units CC and DD (both of which were excavated previously by Ellen Ehrenhard).

0006. ANDE 00378: SURVEY FOR VISITOR CENTER AND ROAD, 1990-1991

Archeological survey for a visitor center and road, conducted February 1990 and September 1990 by Elizabeth A. Horvath (SEAC). Included shovel testing in area of proposed visitor center and parking lot, shovel testing in Pecan Lane area, and test trenches for entrance road.

0007. ANDE 00379: COOKHOUSE LOCATION STUDY, 1989-1994

Investigation to determine location of cookhouse, prior to construction of Visitors Center. Initial walkover conducted by Richard Faust of SEAC; full investigation conducted by Elizabeth Horvath of SEAC. Study failed to reveal the location of the cookhouse.

0008. ANDE 00409: INVESTIGATION FOR A NEW DRAIN LINE, 1991-1992

Archeological investigation for new drain line in area of North Gate, to replace 1930s era drain line installed by Civilian Conservation Corps. Project conducted by John E. Cornelison (SEAC).

0009. ANDE 00429: SECTION 106 COMPLIANCE SURVEY FOR MAINTENANCE BUILDING, 1976

Survey conducted as part of Section 106 compliance for maintenance building. The clearance effort concentrated on park property beyond boundaries of the fort, and revealed the location of a prehistoric site. Principal investigator: R. Faust, SEAC.

0010. ANDE 00430: TEST EXCAVATIONS AT STOCKADE, 1973-1977

Archeological testing in the stockade area by Lewis H. Larson, Jr., and Morgan Ray Crook, Jr., of West Georgia College, under NPS contract no. CX500031635. Objectives of the investigation were to locate and record prison features and to provide preliminary details of construction techniques.

0011. ANDE 00431: HISTORIC STRUCTURES REPORT, 1970

Historic Structures Report by Andersonville Superintendent Edwin S. Bearss.

0012. ANDE 00432: GUNBOAT STREET AND CEMETERY SECTION "P" CLEARANCE PROJECT, 1981

Archeological Clearance Project at Gunboat Street and Cemetery Section "P," conducted by Ellen Ehrenhard (SEAC).

0013. ANDE 00433: SURVEY OF TRACT 01-142 (1983), 1981-1985

Archeological survey of surplus parcel (Tract 01-142), conducted in August 1983 by Teresa Paglione and Richard Johnson of SEAC. The survey revealed the Civil War era Old Dixie Highway, the entrance road to the National Cemetery (ca. 1870-1932), and the Civilian Conservation Corps camp (1934-36).

0014. ANDE 00434: MONITORING OF PROVIDENCE SPRING PARKING AREA, 1986

Monitoring of Providence Spring Parking Area, overseen by John W. Walker (SEAC).

0015. ANDE 00435: MONITORING OF SEPTIC TANK AND DRAIN FIELD AT P.O.W. MUSEUM, 1986

Monitoring of septic tank and drain field area at Prisoner of War Museum. Project archeologist: Allen Cooper, SEAC.

0016. ANDE 00436: MONITORING OF HANDICAP ACCESS RAMPS AT SEXTANT'S HOUSE, 1988

Archeological monitoring of Handicap Access Ramps at the Sextant's House (also referred to as the Cemetery Lodge), conducted in November 1988 by Andrea C. Repp of SEAC.

0017. ANDE 00481: INVESTIGATIONS FOR NEW ENTRANCE ROAD AND VISITORS CENTER, 1993, 1993-1994

Archeological investigations for new entrance road and visitors center, involving shovel tests carried out in December 1993. Principal investigator: John Cornelison (SEAC).

0018. ANDE 00542: CEMETERY EXPANSION (SECTION "J"), 1996-1997

Archeological testing in area of proposed cemetery expansion (Cemetery, Section "J"). Principal investigator: John Cornelison, SEAC.

SERIES II: STILL PICTURES

0001. ANDE 00062

Negatives and prints.

0002. ANDE 00276

Negatives and prints.

0003. ANDE 00322

Negatives, prints, and slides.

0004. ANDE 00355

Negatives, prints, and slides.

- 0005. ANDE 00378**
Negatives and prints.
- 0006. ANDE 00379**
Negatives and prints.
- 0007. ANDE 00409**
Negatives and slides.
- 0008. ANDE 00430**
Negatives, prints, and slides.
- 0009. ANDE 00432**
Negatives.
- 0010. ANDE 00433**
Negatives and prints.
- 0011. ANDE 00481**
Negatives and prints.
- 0012. ANDE 00542**
Negatives.

SERIES III: MAPS

- 0001. ANDE 00062**
- 0002. ANDE 00166**
- 0003. ANDE 00276**
- 0004. ANDE 00322**
- 0005. ANDE 00355**
- 0006. ANDE 00378**
- 0007. ANDE 00409**
- 0008. ANDE 00430**
- 0009. ANDE 00432**
- 0010. ANDE 00433**
- 0011. ANDE 00435**

CONTAINER LIST

Box 1

SERIES I: REPORTS, NOTES, AND CORRESPONDENCE

- Folder 1: ANDE 62 -- Ceramic Inventory by Unit
- Folder 2: ANDE 62 -- Lithics Inventory by Unit
- Folder 3: ANDE 62 -- Artifact Inventory by Unit
- Folder 4: ANDE 62 -- Map Inventory by Provenience
- Folder 5: ANDE 166 -- Correspondence
- Folder 6: ANDE 166 -- Research Design-Planning, 1984
- Folder 7: ANDE 166 -- Research Design-Planning, 1985
- Folder 8: ANDE 166 -- Final Report
- Folder 9: ANDE 166 -- Field Notes
- Folder 10: ANDE 166 -- Resistivity Survey Worksheets

Box 2

- Folder 11: ANDE 276 -- General Correspondence
- Folder 12: ANDE 276 -- Trip Report (Faust)
- Folder 13: ANDE 276 -- Research Design (Compliance)
- Folder 14: ANDE 276 -- Research Design (Planning)
- Folder 15: ANDE 276 -- Draft Report (Figures, Tables, Notes)
- Folder 16: ANDE 276 -- Draft Report (Partials of Final)
- Folder 17: ANDE 276 -- Draft Report (Complete Final)
- Folder 18: ANDE 276 -- Final Report
- Folder 19: ANDE 276 -- Identification of Wood Samples
- Folder 20: ANDE 276 -- Management Plan/Environmental Assessment
- Folder 21: ANDE 276 -- Newspaper Article
- Folder 22: ANDE 276 -- RFP and Related Correspondence
- Folder 23: ANDE 276 -- Budget Expenses
- Folder 24: ANDE 276 -- Field Specimen Log
- Folder 25: ANDE 276 -- Photographic Log (Camera 17894)
- Folder 26: ANDE 276 -- Photographic Log (Camera 17897)

Box 3

- Folder 27: ANDE 276 -- Journal Recording Notes (Prentice)
- Folder 28: ANDE 276 -- Loose Recording Notes (Walker)
- Folder 29: ANDE 276 -- Loose Recording Notes (Crew)
- Folder 30: ANDE 276 -- Transit Recording Notes
- Folder 31: ANDE 276 -- Excavation Unit Forms
- Folder 32: ANDE 276 -- Feature Forms
- Folder 33: ANDE 276 -- Post Hole Forms

Folder 34: ANDE 276 -- Radiocarbon Assay Reports
Folder 35: ANDE 276 -- Miscellaneous Work Notes
Folder 36: ANDE 276 -- Catalog Worksheets/Analysis Forms
Folder 37: ANDE 322 -- General Correspondence
Folder 38: ANDE 322 -- Research Design

Box 4

Folder 39: ANDE 322 -- Final Report
Folder 40: ANDE 322 -- Field Specimen Provenience Form
Folder 41: ANDE 322 -- Photographic Log
Folder 42: ANDE 322 -- Field Journal Notes (Horvath)
Folder 43: ANDE 322 -- Transit Information Forms
Folder 44: ANDE 322 -- Excavation Unit Forms
Folder 45: ANDE 322 -- Artifact Inventory Forms
Folder 46: ANDE 322 -- Artifacts by Field Specimen Numbers
Folder 47: ANDE 322 -- Conservation Information/Artifact Processing Record
Folder 48: ANDE 355 -- Research Design
Folder 49: ANDE 355 -- Final Report
Folder 50: ANDE 355 -- Photo Logs
Folder 51: ANDE 355 -- Field Forms

Box 5

Folder 52: ANDE 378 -- General Artifact Inventory Phase I
Folder 53: ANDE 378 -- General Artifact Inventory Phase II
Folder 54: ANDE 378 -- Ceramic Analysis Forms
Folder 55: ANDE 378 -- CAT Worksheets/Analysis Forms
Folder 56: ANDE 379 -- Trip Reports
Folder 57: ANDE 379 -- Field Specimen Log
Folder 58: ANDE 379 -- Photo Log
Folder 59: ANDE 379 -- Field Notes (Faust)
Folder 60: ANDE 379 -- Field Notebook (Horvath)
Folder 61: ANDE 379 -- Site Plan
Folder 62: ANDE 379 -- Analysis Worksheets
Folder 63: ANDE 379 -- Catalog Worksheets

Box 6

Folder 64: ANDE 379 -- General Artifact Inventory Forms
Folder 65: ANDE 379 -- Proofing Sheets
Folder 66: ANDE 409 -- Correspondence
Folder 67: ANDE 409 -- Trip Report (Cornelison)
Folder 68: ANDE 409 -- Research Design (Cornelison)_
Folder 69: ANDE 409 -- Field Specimen Log
Folder 70: ANDE 409 -- Journal Recording Notes/Photo Log

Folder 71: ANDE 409 -- Feature Forms
Folder 72: ANDE 409 -- Artifact Analysis Forms
Folder 73: ANDE 429 -- Trip Report
Folder 74: ANDE 430 -- Correspondence
Folder 75: ANDE 430 -- 106 Compliance
Folder 76: ANDE 430 -- Research Design/Scope of Project

Box 7

Folder 77: ANDE 430 -- Project Proposal
Folder 78: ANDE 430 -- Criteria
Folder 79: ANDE 430 -- Progress Reports
Folder 80: ANDE 430 -- Research/Rough Draft for Final Report
Folder 81: ANDE 430 -- Final Report
Folder 82: ANDE 430 -- Contracts and Correspondence
Folder 83: ANDE 430 -- Bound Field Notes
Folder 84: ANDE 430 -- Loose Recording Notes/Field Journal
Folder 85: ANDE 430 -- Loose Feature Notes and Forms
Folder 86: ANDE 430 -- Transit Notes/Elevation Log
Folder 87: ANDE 430 -- Stratigraphic Profile (North Gate Feature)
Folder 88: ANDE 430 -- Illustrations

Box 8

Folder 89: ANDE 430 -- Artifact Inventory
Folder 90: ANDE 430 -- Artifact Cards
Folder 91: ANDE 431 -- Report
Folder 92: ANDE 432 -- Correspondence
Folder 93: ANDE 432 -- Trip Reports
Folder 94: ANDE 432 -- Loose Journal Recording Notes
Folder 95: ANDE 432 -- Burial Notes
Folder 96: ANDE 433 -- Correspondence
Folder 97: ANDE 433 -- Final Report
Folder 98: ANDE 433 -- Photographic Log
Folder 99: ANDE 433 -- Field Notes
Folder 100: ANDE 434 -- Correspondence

Box 9

Folder 101: ANDE 435 -- Antiquities Act Permit and Related Correspondence
Folder 102: ANDE 435 -- General Correspondence
Folder 103: ANDE 435 -- Trip Report
Folder 104: ANDE 435 -- Research Design-Planning
Folder 105: ANDE 435 -- Journal Recording Notes
Folder 106: ANDE 435 -- Shovel/Posthole Test Forms
Folder 107: ANDE 435 -- Analytical Notes/Posthole Tests

Folder 108: ANDE 436 -- General Correspondence
Folder 109: ANDE 436 -- Trip Report
Folder 110: ANDE 436 -- Research Design-Planning
Folder 111: ANDE 436 -- Publication Plates

Box 10

Folder 112: ANDE 436 -- Journal Recording Notes
Folder 113: ANDE 436 -- General Artifact Inventory Form
Folder 114: ANDE 481 -- General Correspondence
Folder 115: ANDE 481 -- Trip Report
Folders 116-17: ANDE 481 -- Research Design
Folder 118: ANDE 481 -- State Site Form
Folder 119: ANDE 481 -- Field Specimen Log
Folder 120: ANDE 481 -- Journal Recording Notes
Folder 121: ANDE 481 -- Artifact Analysis Form
Folder 122: ANDE 542 -- Section 106 Compliance
Folder 124: ANDE 542 -- Trip Report

Box 11

Folder 125: ANDE 542 -- Research Design
Folder 126: ANDE 542 -- Field Specimen Log
Folder 127: ANDE 542 -- Photo Log
Folder 128: ANDE 542 -- Journal Recording Notes
Folder 129: ANDE 542 -- Shovel Test Forms
Folder 130: ANDE 542 -- Plan Maps
Folder 131: ANDE 542 -- Analysis Forms

Box 12

SERIES II: STILL PICTURES

Negatives, ANDE 62 to ANDE 378

Box 13

Negatives, ANDE 379 to ANDE 542

Box 14

Prints, ANDE 62 to ANDE 322

Box 15

Prints, ANDE 355 to ANDE 430

Box 16
Prints, ANDE 433 to ANDE 481

Box 17
Slides, ANDE 322 to ANDE 409

Box 18
Slides, ANDE 430

Drawer A
SERIES III: MAPS

ANDE 62 to ANDE 322

Drawer B
ANDE 355 to ANDE 430

Drawer C
ANDE 432 to ANDE 435

THE FREEDOM OF INFORMATION ACT

5 U.S.C. § 552

As Amended in 2002

§ 552. Public information; agency rules, opinions, orders, records, and proceedings

(a) Each agency shall make available to the public information as follows:

(1) Each agency shall separately state and currently publish in the Federal Register for the guidance of the public--

(A) descriptions of its central and field organization and the established places at which, the employees (and in the case of a uniformed service, the members) from whom, and the methods whereby, the public may obtain information, make submittals or requests, or obtain decisions;

(B) statements of the general course and method by which its functions are channeled and determined, including the nature and requirements of all formal and informal procedures available;

(C) rules of procedure, descriptions of forms available or the places at which forms may be obtained, and instructions as to the scope and contents of all papers, reports, or examinations;

(D) substantive rules of general applicability adopted as authorized by law, and statements of general policy or interpretations of general applicability formulated and adopted by the agency; and

(E) each amendment, revision, or repeal of the foregoing

Except to the extent that a person has actual and timely notice of the terms thereof, a person may not in any manner be required to resort to, or be adversely affected by, a matter required to be published in the Federal Register and not so published. For the purpose of this paragraph, matter reasonably available to the class of persons affected thereby is deemed published in the Federal Register when incorporated by reference therein with the approval of the Director of the Federal Register.

(2) Each agency, in accordance with published rules, shall make available for public inspection and copying--

(A) final opinions, including concurring and dissenting opinions, as well as orders, made in the adjudication of cases;

(B) those statements of policy and interpretations which have been adopted by the agency and are not published in the Federal Register;

(C) administrative staff manuals and instructions to staff that affect a member of the public;

(D) copies of all records, regardless of form or format, which have been released to any person under paragraph (3) and which, because of the nature of their subject matter, the agency determines have become or are likely to become the subject of subsequent requests for substantially the same records; and

Figure D.7 Freedom of Information Act

unless the materials are promptly published and copies offered for sale. For records created on or after November 1, 1996, within one year after such date, each agency shall make such records available, including by computer telecommunications or, if computer telecommunications means have not been established by the agency, by other electronic means. To the extent required to prevent a clearly unwarranted invasion of personal privacy, an agency may delete identifying details when it makes available or publishes an opinion, statement of policy, interpretation, staff manual, instruction, or copies of records referred to in subparagraph (D). However, in each case the justification for the deletion shall be explained fully in writing, and the extent of such deletion shall be indicated on the portion of the record which is made available or published, unless including that indication would harm an interest protected by the exemption in subsection (b) under which the deletion is made. If technically feasible, the extent of the deletion shall be indicated at the place in the record where the deletion was made. Each agency shall also maintain and make available for public inspection and copying current indexes providing identifying information for the public as to any matter issued, adopted, or promulgated after July 4, 1967, and required by this paragraph to be made available or published. Each agency shall promptly publish, quarterly or more frequently, and distribute (by sale or otherwise) copies of each index or supplements thereto unless it determines by order published in the Federal Register that the publication would be unnecessary and impracticable, in which case the agency shall nonetheless provide copies of an index on request at a cost not to exceed the direct cost of duplication. Each agency shall make the index referred to in subparagraph (E) available by computer telecommunications by December 31, 1999. A final order, opinion, statement of policy, interpretation, or staff manual or instruction that affects a member of the public may be relied on, used, or cited as precedent by an agency against a party other than an agency only if--

(i) it has been indexed and either made available or published as provided by this paragraph; or

(ii) the party has actual and timely notice of the terms thereof.

(3)(A) Except with respect to the records made available under paragraphs (1) and (2) of this subsection, and except as provided in subparagraph (E), each agency, upon any request for records which (i) reasonably describes such records and (ii) is made in accordance with published rules stating the time, place, fees (if any), and procedures to be followed, shall make the records promptly available to any person.

(B) In making any record available to a person under this paragraph, an agency shall provide the record in any form or format requested by the person if the record is readily reproducible by the agency in that form or format. Each agency shall make reasonable efforts to maintain its records in forms or formats that are reproducible for purposes of this section.

(C) In responding under this paragraph to a request for records, an agency shall make reasonable efforts to search for the records in electronic form or format, except when such efforts would significantly interfere with the operation of the agency's automated information system.

(D) For purposes of this paragraph, the term "search" means to review, manually or by automated means, agency records for the purpose of locating those records which are responsive to a request.

(E) An agency, or part of an agency, that is an element of the intelligence community (as that term is defined in section 3(4) of the National Security Act of 1947 (50 U.S.C. 401a(4))) shall not make any record available under this paragraph to--

Figure D.7 continued

(i) any government entity, other than a State, territory, commonwealth, or district of the United States, or any subdivision thereof; or

(ii) a representative of a government entity described in clause (i).

(4)(A)(i) In order to carry out the provisions of this section, each agency shall promulgate regulations, pursuant to notice and receipt of public comment, specifying the schedule of fees applicable to the processing of requests under this section and establishing procedures and guidelines for determining when such fees should be waived or reduced. Such schedule shall conform to the guidelines which shall be promulgated, pursuant to notice and receipt of public comment, by the Director of the Office of Management and Budget and which shall provide for a uniform schedule of fees for all agencies.

(ii) Such agency regulations shall provide that--

(I) fees shall be limited to reasonable standard charges for document search, duplication, and review, when records are requested for commercial use;

(II) fees shall be limited to reasonable standard charges for document duplication when records are not sought for commercial use and the request is made by an educational or noncommercial scientific institution, whose purpose is scholarly or scientific research; or a representative of the news media; and

(III) for any request not described in (I) or (II), fees shall be limited to reasonable standard charges for document search and duplication.

(iii) Documents shall be furnished without any charge or at a charge reduced below the fees established under clause (ii) if disclosure of the information is in the public interest because it is likely to contribute significantly to public understanding of the operations or activities of the government and is not primarily in the commercial interest of the requester.

(iv) Fee schedules shall provide for the recovery of only the direct costs of search, duplication, or review. Review costs shall include only the direct costs incurred during the initial examination of a document for the purposes of determining whether the documents must be disclosed under this section and for the purposes of withholding any portions exempt from disclosure under this section. Review costs may not include any costs incurred in resolving issues of law or policy that may be raised in the course of processing a request under this section. No fee may be charged by any agency under this section--

(I) if the costs of routine collection and processing of the fee are likely to equal or exceed the amount of the fee; or

(II) for any request described in clause (ii)(II) or (III) of this subparagraph for the first two hours of search time or for the first one hundred pages of duplication.

(v) No agency may require advance payment of any fee unless the requester has previously failed to pay fees in a timely fashion, or the agency has determined that the fee will exceed \$250.

(vi) Nothing in this subparagraph shall supersede fees chargeable under a statute specifically providing for setting the level of fees for particular types of records.

Figure D.7 continued

(vii) In any action by a requester regarding the waiver of fees under this section, the court shall determine the matter de novo, provided that the court's review of the matter shall be limited to the record before the agency.

(B) On complaint, the district court of the United States in the district in which the complainant resides, or has his principal place of business, or in which the agency records are situated, or in the District of Columbia, has jurisdiction to enjoin the agency from withholding agency records and to order the production of any agency records improperly withheld from the complainant. In such a case the court shall determine the matter de novo, and may examine the contents of such agency records in camera to determine whether such records or any part thereof shall be withheld under any of the exemptions set forth in subsection (b) of this section, and the burden is on the agency to sustain its action. In addition to any other matters to which a court accords substantial weight, a court shall accord substantial weight to an affidavit of an agency concerning the agency's determination as to technical feasibility under paragraph (2)(C) and subsection (b) and reproducibility under paragraph (3)(B).

(C) Notwithstanding any other provision of law, the defendant shall serve an answer or otherwise plead to any complaint made under this subsection within thirty days after service upon the defendant of the pleading in which such complaint is made, unless the court otherwise directs for good cause is shown.

(D) Repealed by Pub. L. 98-620, Title IV, 402(2), Nov. 8, 1984, 98 Stat. 3335, 3357.

(E) The court may assess against the United States reasonable attorney fees and other litigation costs reasonably incurred in any case under this section in which the complainant has substantially prevailed.

(F) Whenever the court orders the production of any agency records improperly withheld from the complainant and assesses against the United States reasonable attorney fees and other litigation costs, and the court additionally issues a written finding that the circumstances surrounding the withholding raise questions whether agency personnel acted arbitrarily or capriciously with respect to the withholding, the Special Counsel shall promptly initiate a proceeding to determine whether disciplinary action is warranted against the officer or employee who was primarily responsible for the withholding. The Special Counsel, after investigation and consideration of the evidence submitted, shall submit his findings and recommendations to the administrative authority of the agency concerned and shall send copies of the findings and recommendations to the officer or employee or his representative. The administrative authority shall take the corrective action that the Special Counsel recommends.

(G) In the event of noncompliance with the order of the court, the district court may punish for contempt the responsible employee, and in the case of a uniformed service, the responsible member.

(5) Each agency having more than one member shall maintain and make available for public inspection a record of the final votes of each member in every agency proceeding.

(6)(A) Each agency, upon any request for records made under paragraph (1), (2), or (3) of this subsection, shall--

Figure D.7 continued

(i) determine within twenty days (excepting Saturdays, Sundays, and legal public holidays) after the receipt of any such request whether to comply with such request and shall immediately notify the person making such request of such determination and the reasons therefor, and of the right of such person to appeal to the head of the agency any adverse determination; and

(ii) make a determination with respect to any appeal within twenty days (excepting Saturdays, Sundays, and legal public holidays) after the receipt of such appeal. If on appeal the denial of the request for records is in whole or in part upheld, the agency shall notify the person making such request of the provisions for judicial review of that determination under paragraph (4) of this subsection.

(B)(i) In unusual circumstances as specified in this subparagraph, the time limits prescribed in either clause (i) or clause (ii) of subparagraph (A) may be extended by written notice to the person making such request setting forth the unusual circumstances for such extension and the date on which a determination is expected to be dispatched. No such notice shall specify a date that would result in an extension for more than ten working days, except as provided in clause (ii) of this subparagraph.

(ii) With respect to a request for which a written notice under clause (i) extends the time limits prescribed under clause (i) of subparagraph (A), the agency shall notify the person making the request if the request cannot be processed within the time limit specified in that clause and shall provide the person an opportunity to limit the scope of the request so that it may be processed within that time limit or an opportunity to arrange with the agency an alternative time frame for processing the request or a modified request. Refusal by the person to reasonably modify the request or arrange such an alternative time frame shall be considered as a factor in determining whether exceptional circumstances exist for purposes of subparagraph (C).

(iii) As used in this subparagraph, "unusual circumstances" means, but only to the extent reasonably necessary to the proper processing of the particular requests--

(I) the need to search for and collect the requested records from field facilities or other establishments that are separate from the office processing the request;

(II) the need to search for, collect, and appropriately examine a voluminous amount of separate and distinct records which are demanded in a single request; or

(III) the need for consultation, which shall be conducted with all practicable speed, with another agency having a substantial interest in the determination of the request or among two or more components of the agency having substantial subject matter interest therein.

(iv) Each agency may promulgate regulations, pursuant to notice and receipt of public comment, providing for the aggregation of certain requests by the same requestor, or by a group of requestors acting in concert, if the agency reasonably believes that such requests actually constitute a single request, which would otherwise satisfy the unusual circumstances specified in this subparagraph, and the requests involve clearly related matters. Multiple requests involving unrelated matters shall not be aggregated.

Figure D.7 continued

(C)(i) Any person making a request to any agency for records under paragraph (1), (2), or (3) of this subsection shall be deemed to have exhausted his administrative remedies with respect to such request if the agency fails to comply with the applicable time limit provisions of this paragraph. If the Government can show exceptional circumstances exist and that the agency is exercising due diligence in responding to the request, the court may retain jurisdiction and allow the agency additional time to complete its review of the records. Upon any determination by an agency to comply with a request for records, the records shall be made promptly available to such person making such request. Any notification of denial of any request for records under this subsection shall set forth the names and titles or positions of each person responsible for the denial of such request.

(ii) For purposes of this subparagraph, the term "exceptional circumstances" does not include a delay that results from a predictable agency workload of requests under this section, unless the agency demonstrates reasonable progress in reducing its backlog of pending requests.

(iii) Refusal by a person to reasonably modify the scope of a request or arrange an alternative time frame for processing the request (or a modified request) under clause (ii) after being given an opportunity to do so by the agency to whom the person made the request shall be considered as a factor in determining whether exceptional circumstances exist for purposes of this subparagraph.

(D)(i) Each agency may promulgate regulations, pursuant to notice and receipt of public comment, providing for multitrack processing of requests for records based on the amount of work or time (or both) involved in processing requests.

(ii) Regulations under this subparagraph may provide a person making a request that does not qualify for the fastest multitrack processing an opportunity to limit the scope of the request in order to qualify for faster processing.

(iii) This subparagraph shall not be considered to affect the requirement under subparagraph (C) to exercise due diligence.

(E)(i) Each agency shall promulgate regulations, pursuant to notice and receipt of public comment, providing for expedited processing of requests for records—

(I) in cases in which the person requesting the records demonstrates a compelling need; and

(II) in other cases determined by the agency.

(ii) Notwithstanding clause (i), regulations under this subparagraph must ensure--

(I) that a determination of whether to provide expedited processing shall be made, and notice of the determination shall be provided to the person making the request, within 10 days after the date of the request; and

(II) expeditious consideration of administrative appeals of such determinations of whether to provide expedited processing.

(iii) An agency shall process as soon as practicable any request for records to which the agency has granted expedited processing under this subparagraph. Agency action to deny or affirm denial of a request for expedited processing pursuant to this subparagraph, and failure by an agency to respond in a timely manner to such a request shall be subject to judicial review under paragraph (4), except that the judicial review shall be based on the record before the agency at the time of the determination.

Figure D.7 continued

(iv) A district court of the United States shall not have jurisdiction to review an agency denial of expedited processing of a request for records after the agency has provided a complete response to the request.

(v) For purposes of this subparagraph, the term "compelling need" means--

(I) that a failure to obtain requested records on an expedited basis under this paragraph could reasonably be expected to pose an imminent threat to the life or physical safety of an individual; or

(II) with respect to a request made by a person primarily engaged in disseminating information, urgency to inform the public concerning actual or alleged Federal Government activity.

(vi) A demonstration of a compelling need by a person making a request for expedited processing shall be made by a statement certified by such person to be true and correct to the best of such person's knowledge and belief.

(F) In denying a request for records, in whole or in part, an agency shall make a reasonable effort to estimate the volume of any requested matter the provision of which is denied, and shall provide any such estimate to the person making the request, unless providing such estimate would harm an interest protected by the exemption in subsection (b) pursuant to which the denial is made.

(b) This section does not apply to matters that are--

(1)(A) specifically authorized under criteria established by an Executive order to be kept secret in the interest of national defense or foreign policy and (B) are in fact properly classified pursuant to such Executive order;

(2) related solely to the internal personnel rules and practices of an agency;

(3) specifically exempted from disclosure by statute (other than section 552b of this title), provided that such statute (A) requires that the matters be withheld from the public in such a manner as to leave no discretion on the issue, or (B) establishes particular criteria for withholding or refers to particular types of matters to be withheld;

(4) trade secrets and commercial or financial information obtained from a person and privileged or confidential;

(5) inter-agency or intra-agency memorandums or letters which would not be available by law to a party other than an agency in litigation with the agency;

(6) personnel and medical files and similar files the disclosure of which would constitute a clearly unwarranted invasion of personal privacy;

Figure D.7 continued

(7) records or information compiled for law enforcement purposes, but only to the extent that the production of such law enforcement records or information (A) could reasonably be expected to interfere with enforcement proceedings, (B) would deprive a person of a right to a fair trial or an impartial adjudication, (C) could reasonably be expected to constitute an unwarranted invasion of personal privacy, (D) could reasonably be expected to disclose the identity of a confidential source, including a State, local, or foreign agency or authority or any private institution which furnished information on a confidential basis, and, in the case of a record or information compiled by a criminal law enforcement authority in the course of a criminal investigation or by an agency conducting a lawful national security intelligence investigation, information furnished by a confidential source, (E) would disclose techniques and procedures for law enforcement investigations or prosecutions, or would disclose guidelines for law enforcement investigations or prosecutions if such disclosure could reasonably be expected to risk circumvention of the law, or (F) could reasonably be expected to endanger the life or physical safety of any individual;

(8) contained in or related to examination, operating, or condition reports prepared by, on behalf of, or for the use of an agency responsible for the regulation or supervision of financial institutions; or

(9) geological and geophysical information and data, including maps, concerning wells.

Any reasonably segregable portion of a record shall be provided to any person requesting such record after deletion of the portions which are exempt under this subsection. The amount of information deleted shall be indicated on the released portion of the record, unless including that indication would harm an interest protected by the exemption in this subsection under which the deletion is made. If technically feasible, the amount of the information deleted shall be indicated at the place in the record where such deletion is made.

(c)(1) Whenever a request is made which involves access to records described in subsection (b)(7)(A) and--

(A) the investigation or proceeding involves a possible violation of criminal law; and

(B) there is reason to believe that (i) the subject of the investigation or proceeding is not aware of its pendency, and (ii) disclosure of the existence of the records could reasonably be expected to interfere with enforcement proceedings, the agency may, during only such time as that circumstance continues, treat the records as not subject to the requirements of this section.

(2) Whenever informant records maintained by a criminal law enforcement agency under an informant's name or personal identifier are requested by a third party according to the informant's name or personal identifier, the agency may treat the records as not subject to the requirements of this section unless the informant's status as an informant has been officially confirmed.

(3) Whenever a request is made which involves access to records maintained by the Federal Bureau of Investigation pertaining to foreign intelligence or counterintelligence, or international terrorism, and the existence of the records is classified information as provided in subsection (b)(1), the Bureau may, as long as the existence of the records remains classified information, treat the records as not subject to the requirements of this section.

(d) This section does not authorize the withholding of information or limit the availability of records to the public, except as specifically stated in this section. This section is not authority to withhold information from Congress.

Figure D. 7 continued

(e)(1) On or before February 1 of each year, each agency shall submit to the Attorney General of the United States a report which shall cover the preceding fiscal year and which shall include--

(A) the number of determinations made by the agency not to comply with requests for records made to such agency under subsection (a) and the reasons for each such determination;

(B)(i) the number of appeals made by persons under subsection (a)(6), the result of such appeals, and the reason for the action upon each appeal that results in a denial of information; and

(ii) a complete list of all statutes that the agency relies upon to authorize the agency to withhold information under subsection (b)(3), a description of whether a court has upheld the decision of the agency to withhold information under each such statute, and a concise description of the scope of any information withheld;

(C) the number of requests for records pending before the agency as of September 30 of the preceding year, and the median number of days that such requests had been pending before the agency as of that date;

(D) the number of requests for records received by the agency and the number of requests which the agency processed;

(E) the median number of days taken by the agency to process different types of requests;

(F) the total amount of fees collected by the agency for processing requests; and

(G) the number of full-time staff of the agency devoted to processing requests for records under this section, and the total amount expended by the agency for processing such requests.

(2) Each agency shall make each such report available to the public including by computer telecommunications, or if computer telecommunications means have not been established by the agency, by other electronic means.

(3) The Attorney General of the United States shall make each report which has been made available by electronic means available at a single electronic access point. The Attorney General of the United States shall notify the Chairman and ranking minority member of the Committee on Government Reform and Oversight of the House of Representatives and the Chairman and ranking minority member of the Committees on Governmental Affairs and the Judiciary of the Senate, no later than April 1 of the year in which each such report is issued, that such reports are available by electronic means.

(4) The Attorney General of the United States, in consultation with the Director of the Office of Management and Budget, shall develop reporting and performance guidelines in connection with reports required by this subsection by October 1, 1997, and may establish additional requirements for such reports as the Attorney General determines may be useful.

Figure D.7 continued

(5) The Attorney General of the United States shall submit an annual report on or before April 1 of each calendar year which shall include for the prior calendar year a listing of the number of cases arising under this section, the exemption involved in each case, the disposition of such case, and the cost, fees, and penalties assessed under subparagraphs (E), (F), and (G) of subsection (a)(4). Such report shall also include a description of the efforts undertaken by the Department of Justice to encourage agency compliance with this section.

(f) For purposes of this section, the term--

(1) "agency" as defined in section 551(1) of this title includes any executive department, military department, Government corporation, Government controlled corporation, or other establishment in the executive branch of the Government (including the Executive Office of the President), or any independent regulatory agency; and

(2) "record" and any other term used in this section in reference to information includes any information that would be an agency record subject to the requirements of this section when maintained by an agency in any format, including an electronic format.

(g) The head of each agency shall prepare and make publicly available upon request, reference material or a guide for requesting records or information from the agency, subject to the exemptions in subsection (b), including--

(1) an index of all major information systems of the agency;

(2) a description of major information and record locator systems maintained by the agency; and

(3) a handbook for obtaining various types and categories of public information from the agency pursuant to chapter 35 of title 44, and under this section.

Go to: DOJ FOIA Page // Justice Department Home Page

Last Updated December 23, 2002
usdoj/jmd/lc/caf

Figure D.7 continued

Researcher Registration Form

Name: _____ Date: _____

Picture ID card type, State Control Number: _____

Institutional affiliation: _____

Work address: _____

Phone: _____ FAX: _____ E-Mail: _____

Home address: _____

Phone: _____ FAX: _____ E-Mail: _____

Contacted Park through:

Visit ___ Letter ___ Phone call ___ FAX ___ E-mail ___ FOIA ___ Subpoena ___

Research project summary: _____

Publication plans (publisher, type of publication and date): _____

Researcher Duplication Form Numbers: _____

Other special requirements: _____

Collections used (Name and box number; Use reverse): _____

Figure D.8 Researcher Registration Form

Copyright and Privacy Restrictions

The copyright law of the United States (Title 17, *United States Code*) governs the making of photocopies or other reproductions of copyrighted materials. The various state privacy acts govern the use of materials that document private individuals, groups, and corporations.

Under certain conditions specified in the law, libraries and archives are authorized to furnish a reproduction if the document does not infringe the privacy rights of an individual, group, or corporation. These specified conditions of authorized use include:

- non-commercial and non-profit study, scholarship, or research, or teaching
- criticism, commentary, or news reporting
- as a NPS preservation or security copy
- as a research copy for deposit in another institution

If I, the researcher, later use a copy or reproduction for purposes in excess of "fair use," I, the researcher, am personally liable for copyright, privacy, or publicity infringement and agrees to indemnify the NPS from any legal action as a result of the error. The [Park's] permission to obtain a photographic, xerographic, digital, or other copy of a document **doesn't** indicate permission to publish, exhibit, perform, reproduce, sell, distribute, or prepare derivative works from this document without first obtaining permission from the copyright holder and from any private individual, group, or corporation shown or otherwise recorded.

Permission to publish, exhibit, perform, reproduce, prepare derivative works from, sell, or otherwise distribute the item must be obtained by the researcher separately in writing from the holder of the original copyright (or if the creator is dead from his/her heirs) as well as from any individual(s), groups, or corporations whose name, image, recorded words, or private information (e.g., employment information) may be reproduced in the source material. The holder of the original copyright **isn't** necessarily the National Park Service. The National Park Service is not legally liable for copyright, privacy, or publicity infringement when materials are wrongfully used after being provided to researchers for "fair use."

This institution reserves the right to refuse to accept a copying order if fulfillment of the order is judged in violation of copyright or federal or state privacy or publicity law. This institution also places restrictions on the use of cameras, photocopiers, and scanners in the research room.

I, the researcher, understand and agree to the above terms and will indemnify, defend, save, and hold the National Park Service harmless from all claims, demands, losses, or damages (including attorney's fees and expenses) arising out of any legal action, settlement, or adjustment resulting from my not having followed the guidelines provided above.

Printed Name

Signature

Date

Figure D.9 Copyright and Privacy Restrictions

Access Policies and Rules Governing Use [Name of Park]

Availability

Researchers are encouraged to complete their preliminary research at archives and libraries with a broader topical focus before approaching the holdings of the [Park]. NPS has limited reference staff and research resources that must be made available to researchers whose work focuses on materials available only at the [Park]. Access to materials is dependent upon their physical condition and the level of processing to-date by the NPS. All research must be done on-site in the research room.

Access

- Researchers should submit a written request to the curatorial office, detailing their research project to the curatorial staff.
- Requests for materials should be submitted with enough lead time to allow for the evaluation of the request and the scheduling of curatorial staff to oversee the research.
- All research requests should be addressed to:
Curatorial Office, [Park], [Street Address]
- Approval of all requests will be based on availability of curatorial staff to supervise researchers.
- The curatorial staff at [Park] requests that the researcher read the abstracts in the archival guide or finding aids before requesting to view any collection of documents.
- To ensure the conservation and security of this resource, browsing is not permitted.

Citations

- When crediting the park, list "National Park Service"; the full park name; collection title; the catalog, box, folder, and image numbers; and credit the creator of the item (e.g., photographer).

Reading Room Rules

- Only lead pencils, not pens or markers, may be used for note taking.
- Scanners, portable photocopy machines, and cameras (including digital cameras) are prohibited to avoid damage to materials and copyright infringement.
- Use of tape recorders, typewriters, and portable computers is subject to security procedures. Use of any equipment must not bother other researchers.
- No food, beverages, or smoking will be allowed in the reading room area.
- No coats, packages, containers, folders, cases (including briefcases), or bags (including handbags larger than wallets) are permitted in the reading room area.
- Copying is available within reasonable limits at 25 cents per page.
- The reading room will close if no supervisory staff is available.
- Researchers must maintain quiet in the reading room.
- Researchers register annually and must sign in and out each time they enter or leave.

Figure D.10 Access Policies and Rules Governing Use (Sample)

Access Policies and Rules Governing Use [Name of Park]

Reading Room Rules (continued)

- Researchers may not remove any archival or manuscript materials from the reading room.
- Researchers may work with archival or manuscript materials only in the reading room, not in museum storage or staff work spaces.
- Researchers must submit prepaid written requests for copies or duplicates.
- Researchers must submit for inspection all materials carried into and out of the reading room.
- The park reserves the right to limit access to fragile or restricted collections.
- The park archives is not a lending library. All materials must be used in the reading room.
- Researchers will work with only one document from one folder from one box of materials at a time to avoid damaging a collection's original order.
- Researchers who disregard these rules or endanger the records or the work of others will be denied access.

Permission to obtain a copy for scholarly purposes does not constitute permission to publish

[See Copyright and Privacy Restrictions Statement.]

Handling

- When handling the archival and manuscript materials, only one folder may be removed from a box at a time, and folders must be laid flat on the table.
- Documents should be handled with utmost care and viewed only one at a time.
- Manuscripts and books may not be leaned on, written on, folded, traced over, or handled in any manner that may damage them.
- Researchers must maintain the original order of documents within their folders. Attending staff should be contacted if there is any sign of damage or if items appear to be out of order.
- No attempt should be made to reorder or rearrange the documents or folders or to repair any physical damage.
- Cotton gloves must be used when handling photographic images.
- Only one box or volume of material will be issued at one time.
- Latex gloves must be worn when working with materials that may pose a health hazard.

I understand the rules listed above and will abide by them.

Printed Name of Researcher

Signature of Researcher

Date

Figure D.10 continued

Researcher Duplication Form

Name: _____

ID type and number _____ Type/Amount of deposit: _____

Affiliation _____ Date order was filled: _____ Who filled it: _____

Reason for copies: _____ Publication _____ Research _____ Exhibit _____ Product development
_____ Teaching _____ Criticism _____ Other (Describe): _____

Please describe any special duplication needs, such as blow-ups or rush job (extra cost):

Collection Title	Location: Box, Folder, and Item Numbers (ex.-B35, F18, I44)	Describe Item (e.g., 3x5 color photo of X, Letter by Y)	Number & Type of Copy wanted (1-8 x 10" b/w glossy photo, 1-30K gif file on 3.5" diskette, 5-photocopies)

I understand, that unless authorized elsewhere by Park staff in writing, that the copies provided here are for non-commercial and non-profit research, news reporting, criticism, and commentary purposes only. The provision of copies does not authorize me to publish, exhibit, distribute, sell, perform, reproduce, or prepare derivative works from the copies I receive. I indemnify the park from any legal liability resulting from my use of these copies.

Signature: _____ Date: _____

Figure D.11 Researcher Duplication Form

Appendix E: Archeology

	<u>Page</u>
A. Archeology Classification	E:1
When do I classify objects as archeology?.....	E:1
How do I classify archeology objects?.....	E:1
Can I make changes to the classification?.....	E:1
What if the object consists of more than one material?.....	E:1
How should I catalog floral and faunal specimens that are recovered in an archeological excavation?.....	E:2
What are the classification terms for the archeology classification?.....	E:2
B. Archeology Object Names	E:4
How do I name archeology objects?.....	E:4
Does ANCS+ include a table of object names for archeology?.....	E:4
C. Cataloging Archeology	E:5
Where can I find the guidelines for cataloging archeology objects?.....	E:5
Are there specific cataloging requirements for archeology?.....	E:5
What are the ANCS+ discipline-specific fields for archeology?.....	E:5
D. Within Site Provenience Abbreviations	E:6
E. Archeology Object Name List	E:8

APPENDIX E: ARCHEOLOGY

A. Archeology Classification

1. *When do I classify objects as archeology?*

Use the archeology classification for all objects that were recovered as a result of a systematic investigation using archeological techniques. They may come from dry land or underwater excavations. You should also catalog isolated surface finds as archeology.

Catalog associated archeological field records as archival and manuscript collections. Process them according to the procedures in Appendix D of this handbook. Cross-reference the records and objects.

2. *How do I classify archeology objects?*

Classify archeology objects according to general time period and material of manufacture. The time period is divided into prehistoric (before European contact) or historic (after European contact). Historic archeological objects may have originated from known Native American groups or Anglo-European/Eurasian peoples.

The NPS classification for archeological objects has four lines. You must complete all four lines of the classification.

- line one is the discipline (archeology)
- line two is the time period based on European contact (prehistoric, historic, or unknown)
- line three is a broad class of material, such as mineral or vegetal
- line four is a specific class of material that is a subset of the material on line three, such as stone or wood

Example:	Archeology	Archeology
	Prehistoric	Historic
	Mineral	Vegetal
	Ceramic	Wood

3. *Can I make changes to the classification?*

No. The four-line classification for archeology appears in locked tables in ANCS+. You can't make changes to these tables.

Refer to Section I of Chapter 2 in the *ANCS+ User Manual* for instructions on using ANCS+ to classify and catalog archeological collections.

4. *What if the object consists of more than one material?*

Many objects are made of more than one material. Classify these objects by:

- predominant manufacture material on classification line 3, and entering only one term on classification line 4, *or*
- entering "Composite" on classification line 3, and entering more than one type of material on classification line 4

For example, you could classify a stone axe with a wooden handle using the predominant material or as a composite of stone and wood. Using the predominant material, classification lines 3 and 4 would be:

Line 3:Mineral
Line 4:Stone

Using Composite as the line 3 entry, classification lines 3 and 4 would be:

Line 3:Composite
Line 4: Stone -- Wood

5. *How should I catalog floral and faunal specimens that are recovered in an archeological excavation?*

Catalog floral and faunal specimens recovered in an archeological excavation as archeology. Enter the genus and species on the catalog record, if known. Choose a field where you will enter these data consistently for all specimens.

6. *What are the classification terms for the archeology classification?*

Use the following information in the four classification lines in ANCS+.

Classification Line 1

Archeology

Classification Line 2

Use one of these terms:

Historic (period after European contact)
Prehistoric (period before European contact)
Unknown (unknown at this time)

Classification Line 3

Use one of these terms:

Animal
Composite
Human Remains
Mineral
Unidentified Material
Vegetal

Note: For an object made of more than one material, use either the predominant material or Composite. See Section A.4 above.

Classification Line 4

Classification line 4 terms are dependent on classification line 3 terms.

For Animal, choose one of the following:

Antler
Bone (includes teeth, carapace, fish scales)
Coral
Feather
Hair
Hide (includes skin, fur, hair, leather, sinew gut, etc.)
Horn
Ivory
Other Animal Materials
Quill
Shell

For Composite, choose one of the following:

Antler
Artifactual
Bone
Ceramic
Clay
Coral
Feather
Fibers
Glass
Hair
Hide
Horn
Ivory
Metal
Mud
Mummified
Osteological
Other Animal Materials
Other Human Remains
Other Mineral Materials
Other Plant Materials
Paper
Quill
Reeds
Shell
Soil
Stone
Synthetic
Unidentified
Unknown
Wood

For Human Remains, choose one of the following:

Artifactual (any artifacts made from human remains)
Mummified (includes fortuitous desiccation)
Osteological
Other Human Remains

For Mineral, choose one of the following:

Ceramic
Clay
Glass
Metal
Mud
Other Mineral Materials
Soil
Stone
Synthetic

Note: Ceramic is fired. Clay, Mud, and Soil are unfired.

For Vegetal, choose one of the following:

Fibers
Other Plant Materials(includes gourds, stems, leaves)
Paper
Reeds
Wood (includes twigs, bark)

For Unidentified Material, choose:

Unidentified

B. Archeology Object Names

1. *How do I name archeology objects?*

There is no required lexicon for naming archeology objects. ANCS+ has an Object field, an Alternate Name field, and a Revised Nomenclature field for entering object names. You must complete the Object field. The other two fields are optional.

To name an object, use:

- a park-specific object name list
- the object name list for prehistoric material in Section E of this appendix
- a list of object names from an NPS center, such as the Southeast Archeological Center (SEAC) or the Western Archeological and Conservation Center (WACC)
- *The Revised Nomenclature for Museum Cataloging (Revised Nomenclature)* for a list of suggested object names for historic material

If you are unsure of which list to use, contact your regional/support office curator or regional archeologist.

Note: If your region has an NPS archeological center, it's a good idea to get a list of names from the center. The center's list will include the types of material in your region. Using a center's list will also help keep names consistent within the region.

Be consistent when naming objects. Consistency will give you and others better access to the data in your collection.

2. *Does ANCS+ include a table of object names for archeology?*

No. The ANCS+ Object field is a user-built table for archeology. You can enter the names you want for your site. You may have entries in this table from your ANCS conversion. The program built a table from the archeology entries on your old ANCS records. Check this table to make sure that names are consistent. You can add, modify, and delete entries as needed.

C. Cataloging Archeology

1. *Where can I find the guidelines for cataloging archeology objects?*

Refer to Chapter 3 in this handbook for general guidelines on cataloging. Refer to Section I of Chapter 2 in the *ANCS+ User Manual* for field-by-field instructions for cataloging archeology objects in ANCS+.

2. *Are there specific cataloging requirements for archeology?*

Yes. Provenience data are mandatory for archeology objects. You must enter data in one of the following fields:

- Field Site Number
- State Site Number
- Site Name
- Within Site Provenience

ANCS+ will enter Not Provided in all these fields if you don't complete at least one of them.

Note: A list of within site provenience terms and abbreviations appears in Section D of this appendix.

3. *What are the ANCS+ discipline-specific fields for archeology?*

The following list of fields appears on the archeology discipline-specific screen in ANCS+. None of these fields are mandatory.

Collector
Collection Date
Collector
Color
Decorative Motif
Decorative Technique
Field Specimen Number
Makers Mark
Manufacturing Technique
Object Form
Object Part
Previous Catalog Number
Revised Nomenclature
Temper
Type Name

Note: These fields don't print on the paper Museum Catalog Record, Form 10-254 Rev.. You can print the data from these fields using the All Fields report in ANCS+.

D. Within Site Provenience Abbreviations

Some common within site provenience terms and abbreviations appear below.

<u>Term(s)</u>	<u>Abbreviations</u>
Above mean sea level	AMSL
Alcove	ALC
Antechamber	ACHBR
Area	AREA
Ashpit	ASHP
Associated with	ASSOC
Back	BK
Backdirt	BKD or BKDT
Bedrock	BDRK
Below datum	BD
Below ground surface	BGS
Below mean sea level	BMSL
Below surface	BS
Block	BLK
Bottom	B
Burial	BUR
Cob pit	CP
Core sample	CORE
Column sample	COL
Control	CTR
Controlled surface collection	CSC
Control	CTR
Cremation	CREM
Cross section	CS
Datum	DAT
Depth	D
East	E
East half	EH
Entry	ENTRY
Excavation unit	EU
Exterior	EXT
Feature	FEAT
Feet	FT
Fill	FILL
Find	FIND
Fire pit	FP
Floor	FL
Floor fill	FF
Fort	FORT
Front	F
General plow zone	GPZ
General surface collection	GSC
Grid	GRID
Grid square	GSQ
Hearth	H
Horizon	HOR
House	HSE
Humus	HU
Interior	INT
Kiva	K

Layer	LA
Left	LT
Level	LV
Metal detector test	MDET
Meter	M
Midden	MID
Mile	MI
Mound	MD
Natural level	NATLV
North	N
North half	NH
Original ground surface	OGS
Ossuary	OS
Outline	OL
Piece plot	PP
Pit	P
Pit house	PTHS
Plaza	PL
Plow zone	PZ
Post hole	PH
Post mold	PM
Power auger test	PAT
Profile	PROF
Present ground surface	PGS
Quadrant	Q
Quadrant northeast	QNE
Quadrant northwest	QNW
Quadrant southeast	QSE
Quadrant southwest	QSW
Outlining trenches	TROTL
Right	RT
Room	RM
Section	SECT
Shell concentration	SC
Shovel test	ST
South	S
South half	SH
Stratigraphic survey	SS
Stratum	STRA
Structure	STRU
Structured shovel test (controlled)	SST
Subfloor	SF
Surface	SURF
Square	SQ
Terrace	TERR
Test excavation unit	TU
Test pit	TP
Test square	TSQ
Test trench	TT
Top	T
Transect	TS
Trash pit	TRP
Trash mound	TM
Trench	TR
Trimmings	TRIM
Trowel test	TT
Unit	U
Village site	VS
Lost provenience	UNKNOWN

Unstructured shoveltest (uncontrolled)	UST
Unstructured surface collection (uncontrolled)	USC
Wall	WALL
West	W
West half	WH
Zone	Z

E. Archeology Object Name List

The following list of object names is adapted from the Arizona State Museum. It gives examples of object names for prehistoric objects. It is not a definitive lexicon of acceptable object names. Refer to Section B.1 for information on object names.

Abrader
 Adobe
 Adze Blade
 Adze Head
 Antler Artifact
 Apache Tear
 Apron
 Armor Slat
 Arrow
 Arrow Foreshaft
 Arrow Shaft
 Atlatl
 Atlatl Foreshaft
 Atlatl Shaft
 Awl
 Axe

 Bag
 Bag Handle
 Bag, Apron
 Bag, Awl
 Bag, Pipe
 Ball
 Band
 Basket
 Basket, Burden
 Basketry Fragment
 Basketry Fragment, Cord
 Basketry Fragment, Sherd
 Baton
 Batten
 Bead
 Beaker
 Beam
 Beamer
 Bell
 Belt
 Biface
 Blade
 Blank
 Blank, Disk
 Blanket
 Blouse

Blubber Hook Prong
Blubber Scraper
Bola
Bola Weight
Bone Artifact
Bottle
Bottle, Water Bow
Bow
Bowl
Bowl, Effigy
Bowl, Rattle
Bowl, Seed
Bowl, Sherd
Box
Bracelet
Brush
Buckle
Building Material
Bull Roarer
Bundle
Bundle, Cord
Burin
Button

Cane
Cane Cigarette
Canteen
Canteen, Effigy
Cauldron
Censer
Censer, Effigy
Chisel
Chopper
Cigarette
Clasp
Clay Artifact
Cleaver
Club
Colander
Comb
Concretion
Container
Coprolite
Cord
Cord/Bead
Cordage
Core
Core, Chopper
Core, Hammerstone
Core Fragment
Core/Microblade
Core Tool
Corn Husk Knot
Corn Leaf Knot
Cover
Cover, Pot
Cradle
Cradle Board
Cradle Board Belt

Cradle Board Frame
Crystal
Cup
Cylinder

Dart, Atlatl
Debitage
Die
Digging Stick
Dipper
Dipper Handle
Dipper Sherd
Discoid
Discoid/Hammerstone
Dish
Disk
Drill

Endblade
Effigy, Animal
Effigy, Bird
Effigy Jar, Horned Lizard

Faunal Material
Fetish
Figurine
Fire Drill
Fire Drill Shaft
Flake
Flake, Retouched
Flake Tool
Flake, Utilized
Flake, Waste
Flaker
Flesher
Float
Floral Material
Flute

Gaming Piece
Gouge
Gourd
Gourd Jar
Graver
Grinding Slab
Guard, Wrist

Hairpin
Hammerstone
Handle
Harpoon Foreshaft
Harpoon Head
Harpoon Part
Harpoon Point
Heddle Stick
Hoe
Hook
Hoop
Human Remains

Ivory Artifact

Jar
Jar Base
Jar, Cord
Jar, Effigy
Jar, Gourd
Jar, Sherd
Jar, Seed
Jar, Seed, Bird Effigy

Kiaha
Kiaha Helping-stick
Kilt
Knife
Knife Handle
Knife, Tabular
Knot

Labret
Ladder
Ladle
Ladle Rattle Handle
Ladle, Effigy
Lamp
Leather Artifact
Leister
Lid
Lime Container
Line Weight
Lintel
Loom Anchor
Loop

Mano
Mat
Mat Fragment
Mat/Basketry Fragment
Mat/Cord
Mattock Blade
Maul
Medal
Medicine Box
Medicine Stone
Metate
Microblade
Moccasin
Mug

Nail
Necklace
Necklace/Bracelet
Needle
Needle Case
Net
Net Float
Net, Burden

Ojos de Dios

Pad
Paddle
Palette
Patch
Pebble
Pebble Tool
Peg
Pendant
Pestle
Pick
Pick, Ice
Pigment
Pipe
Pitcher
Pitcher, Effigy
Plank
Plaque
Plate
Plate, Jar Base
Plate, Legged
Plate, Tripod
Point, Bird
Poncho
Pot, Bird
Pot Rest
Pot Ring
Pouch and Contents
Prayer Feather
Prayer Plume
Prayer Stick
Preform
Projectile Point
Punch

Quid
Quiver

Rabbit Stick
Rasp
Rattle
Raw Material
Ring
Ring Vessel
Robe
Robe/Belt
Robe/Textile Fragment
Rod
Rope
Rope/Cord
Rope/Cord/Yarn

Sample
Sandal
Sandal Last
Sandal/Cord
Saucer
Scalp Lock

Scat
Scoop
Scoop, Effigy
Scraper
Scraper, End
Scraper, Side
Seed Beater
Shaft
Shaft Smoother
Shawl
Shell
Sherd Artifact
Sherd Disc
Sherd
Sherd, Worked
Shirt
Shovel Blade
Sinew Twister
Sinker
Slab
Sled Runner
Sling
Snare
Snare Stick
Snowshoe
Sock
Soil
Spall
Spear Point
Spindle
Spindle Stick
Spindle Whorl
Split Twig Figurine
Spoon
Stone Artifact
Stone, Polishing
Stopper
Strainer
Strip

Tablita
Textile
Textile Artifact/Plaster Cast
Thread
Throwing Stick
Tinkler
Toggle
Tooth Artifact
Tooth Fragment
Torch
Tray
Tube
Tumbler
Tump Strap

Ulu Blade
Ulu Handle
Unidentified Artifact

Vase
Vegetal Artifact
Vegetal Material
Vessel
Vessel, Effigy

Weaving Stick
Whetstone
Whistle
Wig/Cord
Winged Object
Wood Artifact
Wristlet

Yarn
Yarn/Cord
Yucca Knot
Yucca Knot/Raw Material

Appendix F: Ethnology

Page

A. Ethnology Classification	F:1
When do I classify objects as ethnology?.....	F:1
How do I classify ethnology objects?	F:1
Can I make changes in the classification?	F:1
What about ethnographic objects from areas outside North America and the Pacific Islands?.....	F:2
How do I classify materials from Oceania?	F:2
What if I'm unsure of the cultural area or cultural group?.....	F:2
What if a group no longer occupies its traditional culture area?.....	F:2
How do I classify objects affiliated with more than one group?	F:2
How do I classify Euro-American style artwork by Native Americans?.....	F:2
How do I classify non-indigenous tradegoods?	F:3
What are the classification terms for the ethnology classification?	F:3
What should I do about names not on the standardized classification lists in Section D?	F:5
B. Ethnology Object Names	F:5
How do I name ethnology objects?.....	F:5
Does ANCS+ include a table of object names for ethnology?.....	F:5
C. Cataloging Ethnology	F:6
Where can I find guidelines for cataloging ethnology?	F:6
How do I record cultural affiliation of use vs. cultural affiliation of manufacture?	F:6
How do I record two distinct cultural affiliations of manufacture?.....	F:6
What are the ANCS+ discipline-specific fields for ethnology?.....	F:6
D. Cultural Area and Cultural Group Classification	F:6

APPENDIX F: ETHNOLOGY

A. Ethnology Classification

1. *When do I classify objects as ethnology?*

Use the ethnology classification for objects produced by or associated with Native Americans or other indigenous peoples from contemporary cultures. Most NPS ethnographic collections are from Native American, Polynesian, or Micronesian peoples who:

- have occupied an area within a park, *or*
- have some other present or past park association

Note: Classify all objects recovered by archeological means as archeology.

Catalog the associated records that document the collection and study of ethnographic collections as archival and manuscript collections. Process them according to the procedures in Appendix D of this handbook. Cross-reference the records and objects.

2. *How do I classify ethnology objects?*

Classify ethnology objects according to the geographic cultural area, the cultural group, and material of manufacture.

The NPS classification for ethnology objects has four lines. You must complete all four lines of the classification.

- line one is the discipline (ethnology)
- line two is the geographic culture area (such as Arctic, Plains)
- line three is the cultural group within the area (such as Aleut, Kiowa)
- line four is the material from which the object is made

Example: Ethnology Ethnology
 Southwest Northeast
 Navajo Huron
 Clay Plant/Stone

Note: Use the most specific cultural group known. For example, use Southen Miwok rather than Miwok.

3. *Can I make changes in the classification?*

No. The four-line classification for ethnology appears in locked tables in ANCS+. You can't make changes to these tables.

Refer to Section III of Chapter 2 in the *ANCS+ User Manual* for instructions on using ANCS+ to classify and catalog ethnology collections.

4. *What about ethnographic objects from areas outside North America and the Pacific Islands?*
- NPS museum collections have few ethnographic objects from South America, Africa, and other geographic areas outside North America and the Pacific Islands. You can use the ethnology classification to catalog objects produced by indigenous peoples from these locations. The ANCS+ program:
- includes other continents as geographic areas for line two of the classification
 - doesn't include cultural groups for these areas
- You must use Unknown for line three of the classification, and enter the cultural group in the Cultural Identification or Culture of Use fields. If you're unsure of the cultural groups for these areas, consult G.P. Murdock's *Outline of World Cultures*, 6th Edition, 1983.
5. *How do I classify materials from Oceania?*
- Use Melanesia, Micronesia and Polynesia in classification line two for the islands of Oceania. Use Island groupings, rather than specific cultural group names for classification line three. See Section D of this appendix for entries. If you know the specific island, village, or cultural group, enter it in the Additional Groups field in ANCS+.
6. *What if I'm unsure of the cultural area or cultural group?*
- If you're not sure of a cultural area or cultural group, use the Possible/Probable Classification field in ANCS+. This field allows you to enter a possible or probable classification for both cultural area and cultural group. This field appears on the ethnology specialty screen.
- You may also use Unknown as an entry for the cultural area and cultural group. If you're totally unsure of an entry, use Unknown.
- Note:** Cultural affiliation may be a sensitive issue in terms of NAGPRA. You may need to do research to prove or confirm the cultural group. Check the accession records for information. For sensitive objects, work with a NPS ethnographer on consultation strategies and identification of cultural affiliation.
7. *What if a group no longer occupies its traditional culture area?*
- Many Native American peoples have been forcibly removed from their traditional homelands. For example, tribes from the Southeast have been relocated within the Plains. Classify the material culture of displaced groups within their traditional cultural area. If the object reflects influences or contacts resulting from relocation, record the appropriate cultural areas. Use the Additional Area and Additional Group fields in ANCS+ to record influence from another cultural area or group. Enter narrative information in the Description field on the catalog record.
8. *How do I classify objects affiliated with more than one group?*
- Enter the primary affiliation in classification line three. Place additional cultural affiliations in the Additional Group, Cultural Identity, and Culture of Use fields in ANCS+.
9. *How do I classify Euro-American style artwork by Native Americans?*
- Make decisions about this type of object on an individual basis. Living artists may have a preference as to whether they want their work to be seen as art or Native American art. In general, use the ethnology classification if you place an object in the museum collection because a recognized Native American created it.

10. *How do I classify non-indigenous tradegoods?*

You can classify trade goods such as mass-produced beads, commercially tanned leather, and brass kettles as either ethnology or history. The classification depends on who used an object. Generally, use ethnology to classify objects you collect because of their association with Native Americans or other indigenous populations. For example, use the ethnology classification when cataloging a bear trap that a Native American used. Use the history classification when cataloging an identical bear trap that a European trapper used.

11. *What are the classification terms for the ethnology classification?*

Use the following information in the four classification lines in ANCS+.

Classification Line 1

Ethnology

Classification Line 2

Select one of the culture areas from the list below.

For North America, use one of the following terms:

Culture Area

Comments

Arctic	For more specific delineation of these culture areas, consult the Smithsonian Institution's <u>Handbook on North American Indians</u> .
Basin	
California	
Caribbean	
Northeast	
Northwest Coast	
Plains	
Plateau	
Southeast	
Southwest	
Subarctic	(includes Northwestern Mexico)
North American Unknown	

For Oceania, use one of the following terms:

Melanesia
Micronesia
Polynesia
Oceania Unknown

For Other Areas, use one of the following terms:

Africa
Asia
Australia
Central America
Europe
Mexico (excludes Northwestern Mexico, see Southwest)
South America
Other Unknown

For Unknown Areas use Unknown.

Classification Line 3

Select one of the cultural groups from the list in Section D of this appendix. Classification line 3 terms are dependent on classification line 2 terms. Many groups are subdivisions of larger groups. Use the most specific group known.

Classification Line 4

Select one of the materials, or combination of materials, from the list below. Enter the major materials from which the object is made. Enter additional materials in the Material field on the catalog record.

Example: For a beaded, hide shirt enter Animal/Glass.

For a stone axe with a wood handle, enter Stone/Plant.

Animal (all parts including bone, teeth, and shell)

Animal/Clay

Animal/Glass

Animal/Metal

Animal/Paper

Animal/Plant

Animal/Stone

Animal/Synthetic

Animal/Unknown

Clay (fired/unfired clay, soil, and plaster)

Clay/Glass

Clay/Metal

Clay/Paper

Clay/Plant

Clay/Stone

Clay/Synthetic

Clay/Unknown

Glass

Glass/Metal

Glass/Paper

Glass/Plant

Glass/Stone

Glass/Synthetic

Glass/Unknown

Metal (manufactured)

Metal/Paper

Metal/Plant

Metal/Stone

Metal/Synthetic

Metal/Unknown

Paper (particularly works of art)

Paper/Plant

Paper/Stone

Paper/Synthetic

Paper/Unknown

Plant (all parts modified or unmodified)

Plant/Stone

Plant/Synthetic

Plant/Unknown

Stone

(rock, crystal, mineral, ore...)

Stone/Synthetic

Stone/Unknown

Synthetic
Synthetic/Unknown

Unknown

12. *What should I do about names not on the standardized classification lists in Section D?*

For cultural groups that aren't on the list, check the Smithsonian Institution's [Handbook on North American Indians](#) or other references. You should be able to place most names under a broad cultural group on the list. Check the name to see if it's out of date. For example, Moqui is an outdated term for Hopi. If the name doesn't fit under any cultural group on the list, enter "Unknown."

B. Ethnology Object Names

1. *How do I name ethnology objects?*

There is no required lexicon for naming ethnology objects. ANCS+ has an Object field, an Alternate Name field, and an Aboriginal Name field for entering object names. You must complete the Object field. The other two fields are optional.

To name an object:

- use a park-specific object name list
- *The Revised Nomenclature for Museum Cataloging (Revised Nomenclature)* for a list of suggested object names for historic material used by indigenous groups

Contact your regional/support office curator or ethnographer for additional sources for ethnographic object names.

Many parks invert the object name. Enter the name, a comma, and a modifier.

Example: Needle, Sewing

Be consistent when naming objects. Consistency will give you and others better access to the data in your collection.

Note: Record information, such as place names, native names, regional designations, and other names, that the collector recorded in the appropriate fields of the catalog record.

2. *Does ANCS+ include a table of object names for ethnology?*

No. The ANCS+ Object field is a user-built table for ethnology. You can enter the names you want for your site. You may have entries in this table from your ANCS conversion. The program built a table from the ethnology entries on your old ANCS records. Check this table to make sure that names are consistent. You can add, modify, and delete entries as needed.

C. Cataloging Ethnology

1. *Where can I find guidelines for cataloging ethnology?*

Refer to Chapter 3 in this handbook for general guidelines on cataloging. Refer to Section III of Chapter 2 in the *ANCS+ User Manual* for field-by-field instructions for cataloging ethnology objects in ANCS+.
2. *How do I record cultural affiliation of use vs. cultural affiliation of manufacture?*

Enter the cultural group that made (manufactured) the object in line three of the classification. Use the Culture of Use field in ANCS+ to note when a different group used the object. Otherwise, culture of use is assumed to be the same as culture of manufacture.

If you know the culture of use but not the culture of manufacture, enter the culture of use in line three of the classification. Enter Unknown in the cultural identity section of the catalog record. Use the Description field to note that the cultural group in the classification is the group that used the object.
3. *How do I record two distinct cultural affiliations of manufacture?*

When more than one distinct cultural affiliation of manufacture exists, enter the most recent in the classification. For example, if the Dakota made a flute, and the Nez Perce made the flute into a dance wand, choose Nez Perce for classification line 3. Place additional information in the Cultural Identity, Additional Groups, and Description fields as part of the history of the object.
4. *What are the ANCS+ discipline-specific fields for ethnology?*

The following list of fields appears on the ethnology discipline-specific screen in ANCS+. None of these fields are mandatory.

Aboriginal Name
Additional Area
Additional Group
Manufacturing Technique
Object Use
Possible/Probable Classification

Note: These fields don't print on the paper Museum Catalog Record, Form 10-254 Rev.. You can print the data from these fields using the All Fields report in ANCS+.

D. Culture Area and Cultural Group Classification

This section lists choices for ethnology classification lines 2 and 3 by culture area and cultural group. The names in parentheses are synonyms. You may use these names in other fields, but the names don't appear in the ANCS+ classification tables.

List the most specific cultural group known (for example, Copper Eskimo, rather than Central Eskimo).

The cultural group classification was developed using the following texts:

Murdock, George P. *Outline of World Cultures*. New Haven, Conn.: Human Relation Area Files, Inc., 1975.

Sturtevant, William C., ed. *Handbook of North American Indians Series*. Washington, D.C.: Smithsonian Institution, 1981.

Swanton, John R. *The Indians of the Southeastern United States*.
Washington, D.C.: Smithsonian Institution, Bureau of American
Ethnology Bulletin 137, 1946.

Swanton, John R. The Indian Tribes of North America. Washington, D.C.:
Smithsonian Institution, Bureau of American Ethnology Bulletin 145,
1952.

Arctic Culture Area

Aleut
 Eastern Aleut (Unalaska)
 Western Aleut (Atka)
Eskimo
 Alaskan Eskimo
 Bering Strait Eskimo
 Koniag
 Kotzebue
 North Alaskan Eskimo
 Northern Interior Eskimo
 Pacific Coast Eskimo
 Agligmiut
 Chugach
 Ikogmiut
 Kaialigamiut
 Kiatagmiut
 Kuskowagamiut
 Magimiut
 Nunivagmiut
 Tugiagamiut
 Baffinland Eskimo
 Central Eskimo
 Caribou Eskimo
 Copper Eskimo
 Iglulingmiut (Iglulik)
 Natsilingmiut (Netsilik)
 Greenland Eskimo
 East Greenland Eskimo
 Polar Eskimo
 West Greenland Eskimo
 Labrador Eskimo
 Mackenzie Eskimo
Unknown

Basin Culture Area

Bannock
Chemehuevi
Gosiute
Kawaiisu
Paiute (Paviotso)
 Mono Lake Paiute
 Northern Paiute
 Owens Valley Paiute
Panamint
Shoshone
 Wind River Shoshone
Ute
Washoe
Unknown

California Culture Area

Achumawi (Pitt River)	Salinan
Atsugewi	Serrano
Cahto	Shasta
Cahuilla	Sinkyone
Chilula	Tataviam (Aliklik)
Chimariko	Tolowa
Chumash	Tubatulabal
Costanoan (Ohlone)	Wailaki
Cupeno	Wappo
Diegueno	Western Mono (Monache)
Ipai (N. Diegueno)	Whilkut
Tipai (S. Diegueno)	Wintu
Esslen	Wiyot
Gabrielino	Yano
Hunchnon	Yokuts
Hupa	Foothill Yokuts
Karok	Northern Valley Yokuts
Kitanemuk	Southern Valley Yokuts
Konkow	Yuki
Konomihu	Coast Yuki
Lassik	Yurok
Luiseno	Unknown
Maidu	
Nisenan (Southern Maidu)	
Northeast Maidu (Northeast/Mountain Maidu)	
Mattole	
Mission Indian*	
Miwok	
Bay Miwok	
Central Miwok	
Coast Miwok	
Lake Miwok	
Northern Miwok	
Plains Miwok	
Southern Miwok	
New River Shasta	
Nomlaki	
Nongatl	
Okwanuchu	
Patwin	
Pomo	
Central Pomo	
Eastern Pomo	
Kashaya Pomo	
Northeastern Pomo (Salt Pomo)	
Northern Pomo	
Southeastern Pomo	
Southern Pomo	

*Mission Indian is a name that can be associated with many tribes. Use a more specific name, if known, and enter the name of the mission in the Description field.

Caribbean Culture Area

Ciboney
Ciguayo
Island Carib
Lucayo
Sub Taino
Taino
Unknown

Northeast Culture Area

Abenaki
 Eastern Abenaki
 Arosaguntacook
 Kennebec
 Penobscot
 Pigwacket
 Western Abenaki
 Cowasuck
 Penacook
 Missisquoi
 Sokoki
Algonquin
Assateague
Bear River
Beothuk
Chawanoke
Chippewa
 Southeastern Chippewa
 Southwestern Chippewa
Choptank
Conoy
Delaware
 Munsee
 Unami
Erie
Fox (Mesquakie)
Hatteras
Housatonic
Huron
Illinois
Iroquois
 Cayuga
 Mohawk
 Oneida
 Onondaga
 Seneca
 Tuscarora Potawatomi
Khionontateronon (Petun)
Kickapoo
Machepungo
Mahican (Mohican)
Maliseet
Mascouten
Massachusett
 Neponset
 Nonantum
 Wessagusset
Massapequa

Matinecock
Meherrin
Menominee
Miami
Micmac
Mohegan
Montauk
Nanticoke
Narragansett
 Coweset
 Pawtuxet
Neusiok
Neutral
Niantic
 Eastern Niantic
 Western Niantic
Nipissing
Nipmuck
Nottaway
Ottawa
Pamlico
Paspataank
Passamaquoddy
Paxtuxent
Paugusset
Pawtucket
 Accominta
 Agawam
 Naumkeag
 Pascataway
 Penacook
Pequot
Pocomoke
Pocumstuck
Pokanoket
Potatuck

Poteskeit
Quiripi
Roanoke
Sauk
Shawnee
Shinnecock
Stockbridge
Susquehannock
Tunxis

(continued)

Northeast Culture Area

Virginia Algonquian
Appamatuck II

Chickahominy
Cuttatawomen I
Cuttatawomen II
Matchotic I
Matchotic II
Moratico
Nansatico
Opiscopank
Pissasec
Potomac
Potapaco
Powhattan Group
 Appamatuck I
 Arrohateck
 Cantauncack
 Caposepock
 Cattachiptico
 Chesapeake
 Kecoughtan
 Kiskiack
 Mattaponi
 Menapacunt
 Nansemond
 Orapaks
 Pamareke
 Pamunkey
 Paraconoski
 Paspahagh
 Potaunk
 Payankatank
 Potchayick
 Powhatan
 Quacohamaock
 Quiyoughcohannock
 Shamapent
 Warraskoyack
 Weanock
 Werowocomoco
 Youghtanund
Rappahannock
Secacawoni
Tauxenent
Wicocomoco
Wampanoag
Weapemeoc
Wenro
Wepawaug
Winnebago
Wyandot
Unknown

Northwest Culture Area

Alsea	Coos (Kus)
Bella Bella	Eyak
Haihais	Haida
Haisla	Kaigani
Bella Coola	Hoh
Chastacosta (Chasta Costa)	Kalapuya (Calapooya)
Chemakum	Atfalati (Tualatin)
Chetco	Chepenafa (Mary's River)
Chinook	Lakmiut
Shoalwater Chinook	Santiam
Clatsop	Yamel (Yam Hill)
Kathlamet	Yoncalla (Yonkalla)
Upper Chinook	Kwakiutl
Clackamas	Kwalhiokwa
Cascade	Nootka
Hood River	Shasta
Wishram	Siuslaw
Wasco	Takelma
Clatskanie	Tlingit
Coast Salish	Auk
Clallam	Chilkat
Chehalis	Gonaho
Copalis	Hanya
Cowlitz	Huna
Duwamish	Hutsnuwu
Humptulips	Kake
Lummi	Kuiu
Makah (Ozette)	Sanya
Muckleshoot	Sitka
Nisqually	Stikine
Nooksak	Sumdum
Pentlatch (Puntlatsh)	Taku
Puyallup	Tongas
Queets (Quaitso)	Yakutat
Quileute	Tolowa
Quinault	Tsimshian
Samish	Gitksan (Kitksan)
Satsop	Niska (Nisrae)
Sechelt	Tutuni
Semiahmoo	Upper Umpqua
Siletz	Yaquina
Skagit	Unknown
Snoqualmi	
Squamish	
Swallah	
Swinomish	
Tillamook	
Wynooche	

Plains Culture Area

Arapaho	Gros Ventre
Arikara (Ree)	Hidatsa (Minitaree)
Assiniboin (Stoney)	Iowa
Blackfeet (Siksika)	Kansa (Kaw)
Blood	Kiowa
Piegan	Kiowa-Apache
Cheyenne	Lipan
Comanche	Mandan
Crow	Missouri
Dakota (Sioux)	Omaha
Santee	Osage
Mdewakanton	Oto
Sisseton	Pawnee
Wahpekute	Plains Cree
Wahpeton	Plains Ojibwa
Teton (Lakota)	Ponca
Brule	Quapaw
Hunkpapa	Sarsi
Miniconjou	Tonkawa
Oglala	Wichita
Sans Arc	Unknown
Sihaspa	
Two Kettle	
Yankton	
Yanktonai	

Plateau Culture Area

Cayuse	Okanagon
Chelan	Palus (Palouse)
Coeur d'Alene	Sanpoil
Columbia	Shuswap
Flathead	Spokan
Kalispel	Tenino
Lower Kalispel	Thompson
Upper Kalispel	Umatilla
Klamath	Walla Walla
Klikitat	Wanapam
Kutenai	Wenatchi (Wenatchee)
Lower Kutenai	Wishram
Upper Kutenai	Yakima
Lake	Unknown
Lilloet	
Modoc	
Molala	
Nez Perce	
Nicola	

Southeast Culture Area

Acolapissa	Manahoac
Ais	Meherrin
Alabama	Michigamea
Amacano	Mobile
Amacano	Monacan
Caparaz	Muskogee (Creek)
Chine	Abihka
Apalachee	Coosa
Apalachicola	Coweta
Atakapa	Enfaula
Bayougoula	Kashihta
Bidai	Kolomi
Biloxi	Ouchai
Caddo	Wiwohka
Adai	Nacogdoche
Adai	Nahyssan
Eyeish	Napochi (Nabochi)
Hasinai	Natchez
Hainai	Opelousa
Nabedache	Pakana
Nacachau	Quinipissa
Nacono	Seminole
Nechau	Mikasuki
Kadohadacho	Oconee
Cahinnio	Taensa
Kadohadacho	Tamathli (Tamali)
Yatasi	Taposa
Natchitoches	Tekesta (Tequesta)
Doustioni	Timucua (Utina)
Washita	Acuera
Calusa	Onatheaque
Capinans	Potano
Catawba	Saturiwa
Chakchiuma	Tacatacuru
Houma	Yui
Chatot	Tiou
Chawasha	Tohome
Cheraw	Tukabahchee
Cherokee	Tunica
Chiaha	Tuskegee
Chickasaw	Tutelo
Chitimacha	Waccamaw
Choctaw	Wakokai
Chowanoc	Washa
Cusabo	Wateree
Eno	Woccon
Hitchiti	Yadkin
Okmulgee	Yazoo
Houma	Yuchi
Kaskinampo	Unknown
Kaeledji	
Keyauwee	
Koasati	
Koroa	
Lumbee	
Machapunga	

Southwest Culture Area

Apache	Tewa (Tegua), Northern
Chiricahua Apache	Nambe
Jicarilla Apache	Projoaque
Lipan Apache	San Ildefonso
Mescalero Apache	San Juan
Western Apache	Santa Clara
Cahita	Tesuque
Mayo	Tiwa (Tigua)
Mayoyahui	Northern Tiwa
Yaqui	Picuris
Cocopa	Taos
Halchidoma	Southern Tiwa
Maricopa	Isleta
Mohave (Mojave)	Sandia
Navajo (Navaho)	Tortugas
Nayarit	Ysleta Tiwa
Cora	Senecu del Sur
Huichol	Ysleta del Sur
Opata	Zuni
Eudeve	Seri
Jova	Tarahumara
Opata	Tarahumara
Pai	Warihio (Varohio, Guarijio)
Havasupai	Tubar (Chinipa)
Walapai (Hualapai)	Yuma (Quechan)
Yavapai	Unknown
Piman	
Papago	
Pima	
Pima Bajo (Lower Pima, Nevome)	
Sand Papago (Arenenos)	
Tepeguan	
Piro (Socorro del Sur)	
Pueblo	
Hopi	
Hopi	
Hopi Tewa (Hano)	
Jemez	
Keres	
Eastern Keres	
Cochiti	
Santa Ana	
Santo Domingo	
San Felipe	
Zia	
Western Keres	
Acoma	
Laguna	
Pecos	

Subarctic Culture Area

Ahtna	Kutchin
Attikamek	Montagnais
Bear Lake	Mountain Indians
Beaver	Naskapi
Carrier	Ojibwa (Chippewa)
Chilcotin	Northern Ojibwa
Chipewyan	Saulteaux
Cree	Sekani
East Cree	Slavey
West Main Cree	Tagish
Western Woods Cree	Tahltan
Dogrib	Tanaina
Han	Tanana
Hare	Tsesaut
Holikachuk	Tutchone
Ingalik	Yellow Knife
Inland Tlingit	Unknown
Kaska	
Kolchan	
Koyukan	

Oceania

<i>Melanesia</i>	<i>Polynesia</i>
Admiralty Islands	Austral Islands
Bismark Archipelago	Chatham Islands
Fiji	Cook Islands
Loyalty Islands	Easter Island (Rapanui)
New Caledonia	Ellice Islands
New Herbrides	Hawaiian Islands
New Guinea	Marquesas Islands
Solomon Islands	Mangareva (Gambier Islands)
Unknown	New Zealand
	Nive (Savage) Island
<i>Micronesia</i>	Phoenix Islands
Bonin Islands	Pitcairn
Caroline Islands	Samoa
Gilbert Islands	Society Islands
Mariana Islands	Tokelau Islands
Marcus Islands	Tonga
Marshall Islands	Tuamotu Archipelago
Wake	Unknown
Unknown	

Oceania

The Oceania classification options above are further defined below.

Polynesia

Austral Islands (including Raivavae, Rapa Rimatara, Rurutu, Tubai)
Chatham Islands
Cook Islands (including Aitutaki, Atiu, Hervey, Mangaia, Manihiki,
 Peurhyn, Pukapuka (Danger), Rarotonga, Suwarrow, etc.)
Easter Island (Rapanui)
Ellice Islands (including Nukufetau, Nukulaelae, etc.)

Hawaiian Islands
Marquesas Islands (including Atuona, Fatuhiva, Hivaoa, Nukuhiva, Omoa)

Mangareva (Gambier Islands) (including Akarema, Rikitea, Taravai,
Temoe, etc.)
New Zealand
Nive (Savage) Island
Phoenix Islands (including Canton, Hull, etc.)
Pitcairn
Samoa (including Apra, Manua, Pago Pago, Savali, Swains, Upolu, etc.)
Society Islands (including Bora Bora, Huahine, Mahetia, Maupiti, Taiatea,
Tahiti)
Tokelau Islands (including Atafu, Fakaofu, Nukunono)
Tonga (including Eau, Haapai, Niua, Nivafou, Tobutabu, Vavau)
Tuamotu Archipelago (including Anaa, Aratiki, Fagatau, Makatea, Napuka,
Raraka, etc.)

Melanesia

Admiralty Islands (including Matty, Hermit and Purdy Islands)
Bismark Archipelago (including Duke of York, New Britain, New Hanover,
New Ireland, etc.)
Fiji (including Fulanga, Gau, Kambara, Koro, Lau, Oreata, Tareuni,
Yasawa, etc.)
Loyalty Islands
New Caledonia
New Herbrides
New Guinea
Solomon Islands

Micronesia

Bonin Islands
Caroline Islands (including Kusaie and Mortlock)
Gilbert Islands (including Apiang, Arorae, Ibu, Koti, Maiana, Makin,
Nauru, Tarawa, Takou, etc.)
Mariana Islands (including Ajuigan, Guam, Pagan, Rota, Saipan, Tinian,
Tumon)
Marcus Islands
Marshall Islands (including Arno, Bikini, Ebon, Eniwetok, Jaluit, Lurunor,
Majuro, Mejit, etc.)
Wake

Other areas

See Section A.4 in this appendix.

Note: For Line 3, Culture Group Entries, refer to G.P. Murdock's *Outline of World Cultures*.

Appendix G: History

	<u>Page</u>
A. History Classification	G:1
When do I classify objects as history?.....	G:1
How do I classify history objects?	G:1
Can I make changes to the classification?	G:1
How do I get a copy of <i>Revised Nomenclature</i> ?.....	G:1
How do I use <i>Revised Nomenclature</i> ?	G:1
How do I classify an object that has been modified from its original function?.....	G:1
How do I classify an object that serves more than one function?.....	G:2
What are the classification terms for the history classification	G:2
B. History Object Names	G:2
How do I name history objects?.....	G:2
Why does the NPS use a required lexicon for naming history objects?	G:3
What if I know the function of an object but don't know its name?.....	G:3
How do I know if a name is in the lexicon?.....	G:3
Why do some of my records have object names that aren't in the lexicon?	G:3
Are there NPS-specific rules for using <i>Revised Nomenclature</i> and naming objects?.....	G:3
How do I name fragments and parts of objects?.....	G:4
How do I name models and samples?	G:4
How do I name product packages and containers?	G:4
How do I name consumable products?	G:5
What is the Supplementary History Object Term List?.....	G:5
How do I add a name to the Supplementary Object Term List?.....	G:5
C. Cataloging History	G:6
Where can I find the guidelines for cataloging history objects?.....	G:6
What are the ANCS+ discipline-specific fields for history?.....	G:6
D. Revised Nomenclature Hierarchical Classification	G:6
E. Supplementary History Object Term List	G:8

APPENDIX G: HISTORY

A. History Classification

1. *When do I classify objects as history?*

Use the history classification for materials made or used by cultures with a written tradition up to the present time. Historic objects relate to the people, activities, and events associated with a park's mission, themes, and history.

Catalog archives and manuscript collections as history according to the procedures in Appendix D of this handbook.

2. *How do I classify history objects?*

The NPS uses *The Revised Nomenclature for Museum Cataloging* (American Association for State and Local History, 1988) to classify history objects. *Revised Nomenclature's* classification system is based on an object's original intended function.

The NPS classification for history objects has three lines. You must complete all three lines of the classification.

- line one is the discipline (history)
- line two is one of the ten broad categories in *Revised Nomenclature*, such as Furnishings or Communication Artifacts
- line three is one of the classification terms under the category in line two, such as Furniture or Documentary Artifact

Example: History History
 Personal Artifacts Tools and Equipment for Materials
 Toilet Article Animal Husbandry Tools and Equipment

3. *Can I make changes to the classification?*

No. The three-line classification for history appears in locked tables in ANCS+. You can't make changes to these tables. *Revised Nomenclature* has categories for Other Tools & Equipment and an Unclassifiable Artifacts category. Use these categories for objects that don't fit under a more specific category.

Refer to Section IV of Chapter 2 in the *ANCS+ User Manual* for instructions on using ANCS+ to classify and catalog history collections.

4. *How do I get a copy of Revised Nomenclature?*

When the NPS adopted the use of *Revised Nomenclature*, copies of the book were sent to all the parks. If you don't have a copy at your site, contact the Supply and Equipment Program of the Museum Management Program.

5. *How do I use Revised Nomenclature?*

Read the first three chapters of the book before you begin to catalog. These chapters tell you how the classification system works and explain how to use the book. Chapter III has definitions of the categories and classifications along with reference sources for identifying objects.

6. *How do I classify an object that has been modified from its original function?*

Base the classification on the most recent function. For example, classify a boot made into a lamp as a Lighting Device.

7. *How do I classify an object that serves more than one function?*

Base the classification on the primary function. For example, classify a thermometer advertising a soft drink as Meteorological Tools & Equipment.

The primary function may not always be easy to determine. It may depend on the purpose for your collection.

Note: There is also a Multiple Use Artifacts classification for objects that fit under more than one classification.

8. *What are the classification terms for the history classification?*

Use the following information in the three classification lines in ANCS+.

Classification Line 1

History

Classification Line 2

Use one of the following ten categories:

Structures
Furnishings
Personal Artifacts
Tools & Equipment for Materials
Tools & Equipment for Science & Technology
Tools & Equipment for Communication
Distribution & Transportation Artifacts
Communication Artifacts
Recreational Artifacts
Unclassifiable Artifacts

Classification Line 3

Classification line 3 terms are dependent on classification line 2 terms. See the list of classification terms in Section D of this appendix.

B. History Object Names

1. *How do I name history objects?*

You must use the *Revised Nomenclature* lexicon for naming history objects. The NPS has expanded this lexicon with object terms from the Supplementary History Object Term List. See Section E of this appendix for a copy of this list. The Object field for history records in ANCS+ has both the lexicon and the supplementary terms in a locked table. You must complete this field.

Revised Nomenclature terms are made up of a single noun or a noun and an adjective. Terms are inverted, meaning that the noun comes before the adjective.

Example: Mitt, Catcher's

ANCS+ also has an Alternate Name field and an *Art and Architecture Thesaurus (AAT)* field for naming history objects. Use of these fields is optional.

Be consistent when naming objects. Consistency will give you and others better access to the data in your collection.

2. *Why does the NPS use a required lexicon for naming history objects?*
- Use of the *Revised Nomenclature* lexicon makes object names consistent within the collection and between sites. For example, purse, handbag, and pocketbook are all names for the same object. When you consistently use one term for an object, it's much easier to search your data.
- Note:** Use the Alternate Name field in ANCS+ to preserve regional and local names for an object.
3. *What if I know the function of an object but don't know its name?*
- Chapter IV in *Revised Nomenclature* has a list of object terms for each classification. Check here when you know the function of an object but are uncertain of a name. For example, if you know a tool is from a woodworking shop, look for an appropriate name under Woodworking Tools & Equipment.
4. *How do I know if a name is in the lexicon?*
- Chapter V in *Revised Nomenclature* is an alphabetical list of object terms that includes the classification for each term. You can also search the lexicon table in ANCS+.
5. *Why do some of my records have object names that aren't in the lexicon?*
- The old ANCS program didn't include the *Revised Nomenclature* lexicon. Park staff had to use the book to find correct object terms. If your park didn't follow the book, your history records may have object names that aren't in the lexicon. These names were converted into ANCS+.
- The NPS also adopted modifications to *Revised Nomenclature* to help standardize entries in the old ANCS program. Modifications included:
- the use of the terms Fragment and Part with any acceptable object name
 - placing specific object names and modifiers in parentheses after the *Revised Nomenclature* term
- Your converted records may have entries with these modifications. You may no longer make modifications in the Object field, but you can enter modified names in the Alternate Name field.
6. *Are there NPS-specific rules for using Revised Nomenclature and naming objects?*
- Yes. The NPS uses the following modifications with *Revised Nomenclature*. You may:
- use an object term with any classification; you don't need to use the classification that appears in the book for a particular object (*Revised Nomenclature*, page II-3, option 3)
 - use the term Problematic (as a last resort) with any classification to show that you know the object's function but not its name (*Revised Nomenclature*, page II-4)
 - place any accepted object term under the Toy classification (*Revised Nomenclature*, page II-6)
 - place souvenirs and mementos created primarily to record an event under the Documentary Artifact classification (*Revised Nomenclature*, page II-6)

7. *How do I name fragments and parts of objects?*

Enter the name of the object in the Object field. Use the Classification, Alternate Name, Description, and Condition fields to show whether the object is complete. For example, if you only have the drawer to a chest:

- enter Chest in the Object field
- enter Fragment in the Condition field
- classify the object as an Artifact Remnant
- enter Chest Drawer in the Alternate Name field
- note that the rest of the piece is missing in the Description field

8. *How do I name models and samples?*

Almost any object can be a model or sample. Add a dash and the term Model or Sample to the object name, and enter it in the Alternate Name field (*Revised Nomenclature*, page II-5).

Example: Car, Cable-Model

Make a note in the Description field that the object is a model or sample.

9. *How do I name product packages and containers?*

Use a generic modifier, such as Foodstuff, to describe the contents of empty product packages and containers (*Revised Nomenclature*, page II-5). Enter the brand name or specific product name in the Alternate Name field.

Example: Jar, Foodstuff in the Object field
Jar, Mayonnaise in the Alternate Name field

If the lexicon doesn't have an appropriate generic entry, enter the name for the container in the Object field. Use the Alternate Name field to enter a generic or specific product name.

The following list includes examples of generic content names

Foodstuff
Medicine
Toiletry
Pesticide
Liquor
Condiment
Tobacco
Cleaning Product

Note: Use the same procedures for naming packages and containers that contain their contents. Use the Description field to note that the package or container still has its contents.

10. *How do I name consumable products?*

If the product is in a container, see the previous question. Usually you will catalog the container and refer to the product. In rare cases, you may need to catalog the product itself. The lexicon has a few generic names for products, such as Foodstuff, Medicine, Chemical, and Raw Material. Use one of these terms and enter a specific name for the product in the Alternate Name field.

Consult your regional/support office curator or the National Catalog office if you can't find an appropriate product name.

11. *What is the Supplementary History Object Term List?*

The Supplementary History Object Term List is a list of object names that the NPS has added to the *Revised Nomenclature* lexicon. The ANCS+ lexicon for naming history objects includes the names on the list.

See Section E of this appendix for a copy of the list.

12. *How do I add a name to the Supplementary Object Term List?*

The use of ANCS+ has greatly reduced the need to add names to the lexicon. You should be able to find a broad term in the lexicon to name most objects. Use the Alternate Name field for specific names that don't appear in the lexicon.

<i>If you...</i>	<i>Then...</i>
can't find an appropriate name,	contact the National Catalog office at 304-535-6204 for assistance.
need to add a name to the lexicon,	fax a copy of the name and a description of the object to the National Catalog office at 304-535-6203.

Subject specialists will review the proposed addition. If it's approved, the name will be added to the lexicon in the next update of ANCS+. National Catalog staff will give you an appropriate name to use, or let you know that the name will be added to the lexicon.

Note: Webster's Third International Dictionary is the standard dictionary to use when proposing additions to the Supplementary History Object Term List.

<i>If the name...</i>	<i>Then...</i>
is approved to go in the lexicon,	use Problematic as the object name until the lexicon is updated, and send the record to the National Catalog with your annual submission.

You can enter the specific name in the Alternate Name field. Correct the catalog record when you receive an update of the lexicon.

Note: Section E in this appendix (Supplementary History Object Term List) will be updated as needed.

C. Cataloging History

1. *Where can I find the guidelines for cataloging history objects?*
2. *What are the ANCS+ discipline-specific fields for history?*

Refer to Chapter 3 in this handbook for general guidelines on cataloging. Refer to Section IV of Chapter 2 in the *ANCS+ User Manual* for field-by-field instructions for cataloging history objects in ANCS+.

The following list of fields appears on the history discipline-specific screen in ANCS+. None of these fields are mandatory.

Copyright
Format
Genre
Inscription/Marks
Object Use
Patent Date
Process/Technique of Manufacture
School
Significant Event
Style
Subjects
Term (AAT)
Title

Note: ANCS+ contains the lexicon for the *Art and Architecture Thesaurus (AAT)*. The *AAT* is a standardized vocabulary for fine arts, architecture, decorative art, and material culture of the Western world.

D. Revised Nomenclature Hierarchical Classification

STRUCTURES

BUILDING
BUILDING COMPONENT
SITE FEATURE
OTHER STRUCTURE

FURNISHINGS

BEDDING
FLOOR COVERING
FURNITURE
HOUSEHOLD ACCESSORY
LIGHTING DEVICE
PLUMBING FIXTURE
TEMPERATURE CONTROL DEVICE
WINDOW OR DOOR COVERING

PERSONAL ARTIFACTS

ADORNMENT
CLOTHING
 Clothing – Footwear
 Clothing – Headwear
 Clothing – Outerwear
 Clothing – Underwear
 Clothing – Accessory
PERSONAL GEAR
TOILET ARTICLE

*TOOLS & EQUIPMENT FOR
MATERIALS*

AGRICULTURAL T&E
ANIMAL HUSBANDRY T&E
FISHING & TRAPPING T&E
FOOD T&E
 Food Processing T&E
 Food Service T&E
FORESTRY T&E
GLASS, PLASTICS, CLAYWORKING T&E
LEATHER, HORN, SHELLWORKING T&E
MASONRY & STONWORKING T&E
METALWORKING T&E
MINING & MINERAL HARVESTING T&E
PAINTING T&E
PAPERMAKING T&E
TEXTILEWORKING T&E
WOODWORKING T&E
OTHER T&E FOR MATERIALS
 Basket, Broom, Brush Making T&E
 Cigar Making T&E
 Lapidary T&E
 Wigmaking T&E

*TOOLS & EQUIPMENT FOR
SCIENCE & TECHNOLOGY*

ACOUSTICAL T&E
ARMAMENT T&E
 Armament – Firearm
 Armament – Edged
 Armament – Bludgeon
 Armament – Artillery
 Armament – Ammunition
 Armament – Body Armor
 Armament – Accessory
ASTRONOMICAL T&E
BIOLOGICAL T&E
CHEMICAL T&E
CONSTRUCTION T&E
ELECTRICAL & MAGNETIC T&E
ENERGY PRODUCTION T&E
GEOLOGICAL T&E
MAINTENANCE T&E
MECHANICAL T&E
MEDICAL & PSYCHOLOGICAL T&E
MERCHANDISING T&E
METEOROLOGICAL T&E
NUCLEAR PHYSICS T&E
OPTICAL T&E
REGULATIVE & PROTECTIVE T&E
SURVEYING & NAVIGATIONAL T&E
THERMAL T&E
TIMEKEEPING T&E
WEIGHTS & MEASURES T&E
OTHER T&E FOR SCIENCE & TECHNOLOGY

**TOOLS & EQUIPMENT FOR
COMMUNICATION**

DATA PROCESSING T&E
DRAFTING T&E
MUSICAL T&E
PHOTOGRAPHIC T&E
PRINTING T&E
SOUND COMMUNICATION T&E
TELECOMMUNICATION T&E
VISUAL COMMUNICATION T&E
WRITTEN COMMUNICATION T&E
OTHER T&E FOR COMMUNICATION

**DISTRIBUTION &
TRANSPORTATION
ARTIFACTS**

CONTAINER
AEROSPACE TRANSPORTATION
 Aerospace Transportation – Equipment
 Aerospace Transportation – Accessory
LAND TRANSPORTATION
 Land Transportation – Animal-Powered
 Land Transportation – Human-Powered
 Land Transportation – Motorized
 Land Transportation – Accessory
RAIL TRANSPORTATION
 Rail Transportation – Equipment
 Rail Transportation – Accessory
WATER TRANSPORTATION
 Water Transportation – Equipment
 Water Transportation - Accessory

**COMMUNICATION
ARTIFACTS**

ADVERTISING MEDIUM
ART
CEREMONIAL ARTIFACT
DOCUMENTARY ARTIFACT
EXCHANGE MEDIUM
PERSONAL SYMBOL

RECREATIONAL ARTIFACTS

GAME
PUBLIC ENTERTAINMENT DEVICE
RECREATIONAL DEVICE
SPORTS EQUIPMENT
TOY

UNCLASSIFIABLE ARTIFACTS

ARTIFACT REMNANT
FUNCTION UNKNOWN
MULTIPLE USE ARTIFACTS

**E. Supplementary History
Object Term List**

The attached Supplementary History Object Term List was last updated in 1993. There have been no additions to the list since that date. Use of the Alternate Name field in ANCS+ has greatly reduced requests for new object names. The list will be updated as names are approved and added to the ANCS+ *Revised Nomenclature* lexicon.

See Section B.12 of this appendix for information on proposing additions to the list.

NATIONAL PARK SERVICE
1993 SUPPLEMENTARY HISTORY OBJECT TERM LIST

OBJECT TERM AND MODIFIER	CLASSIFICATION
ABSORBER, SHOCK	WATER TRANSP.-ACCESSORY
ABSTRACT	DOCUMENTARY ARTIFACT
ACT	DOCUMENTARY ARTIFACT
ACT, CONGRESSIONAL	DOCUMENTARY ARTIFACT
ADAPTOR, FLASH	PHOTOGRAPHIC T&E
ADAPTOR, PLUG	ELECTRICAL & MAGNETIC T&E
ADAPTOR, RING	PHOTOGRAPHIC T&E
ADDRESSOGRAPH	PRINTING T&E
ADVERTISEMENT	ADVERTISING MEDIUM
AFFIDAVIT	DOCUMENTARY ARTIFACT
ALARM, FIRE/INTRUSION	REGULATIVE & PROTECTIVE T&E
ANODE	ELECTRICAL & MAGNETIC T&E
ANTICREEPER	RAIL TRANSP.- ACCESSORY
APPARATUS, INSPECTION	SOUND COMMUNICATION T&E
APPLICATION, MEMBERSHIP	DOCUMENTARY ARTIFACT
APRON, CARPENTER'S	CLOTHING-OUTERWEAR
AQUAKNOT	SURVEYING & NAVIGATIONAL T&E
ARCHPIPE, HOT BLAST	BUILDING COMPONENT
ARRESTER, SPARK	ELECTRICAL & MAGNETIC T&E
AWARD	DOCUMENTARY ARTIFACT
BAG, BARRACK	PERSONAL GEAR
BAG, COLLAR	PERSONAL GEAR
BAG, OIL	WATER TRANSP.-ACCESSORY
BAG, TOILETRY	PERSONAL GEAR
BAG, TRASH	HOUSEHOLD ACCESSORY
BAILER, WELL	ENERGY PRODUCTION T&E
BALE, HEAD	WATER TRANSP.-ACCESSORY
BALL, GOLF	SPORTS EQUIPMENT
BALL, PISTOL	ARMAMENT-AMMUNITION
BALL, TIME	VISUAL COMMUNICATION EQ
BAND	METALWORKING T&E
BAND, CIGAR	PERSONAL GEAR
BAR, DOOR	BUILDING COMPONENT
BAR, JACK	RAIL TRANSP.-ACCESSORY
BAR, REINFORCING	MULTIPLE USE ARTIFACTS
BAS-RELIEF	ART
BASKET, SKI POLE	LAND TRANSP.-HUMAN-POWERED
BASTER	FOOD PROCESSING T&E
BATTEN	BUILDING COMPONENT
BATTLEMENT	TOY
BAYONET	ARMAMENT-EDGED
BEAM	BUILDING COMPONENT

NATIONAL PARK SERVICE
1993 SUPPLEMENTARY HISTORY OBJECT TERM LIST

OBJECT TERM AND MODIFIER	CLASSIFICATION
BEAM, TRUSS	BUILDING COMPONENT
BEAR	WATER TRANSP.-ACCESSORY
BEARING	WATER TRANSP.-ACCESSORY
BEARING, BALL	MECHANICAL T&E
BED, HOSPITAL	MEDICAL & PSYCHOLOGICAL T&E
BELL, FISHING	FISHING & TRAPPING T&E
BELT, FAN	LAND TRANSP.-ACCESSORY
BENDER, ANGLE	METALWORKING T&E
BIBLE	DOCUMENTARY ARTIFACT
BIN, DOUGH	FOOD PROCESSING T&E
BIN, FILING	WRITTEN COMMUNICATION T&E
BINNACLE	WATER TRANSP.-ACCESSORY
BITT	WATER TRANSP.-ACCESSORY
BLADE	MULTIPLE USE ARTIFACTS
BLOCK, FUSE	ENERGY PRODUCTION T&E
BLOCK-AND-TACKLE	WATER TRANSP.-ACCESSORY
BLOWER	ANIMAL HUSBANDRY T&E
BOARD, BULLETIN	WRITTEN COMMUNICATION T&E
BOARD, DRYING	LEATHER, HORN, SHELLWORKING
BOARD, GAUGE	WATER TRANSP.-ACCESS
BOARD, SERVING	TEXTILEWORKING T&E
BOAT, TORPEDO	WATER TRANSPORTATION EQ
BOBBIN, SEWING MACHINE	TEXTILEWORKING T&E
BOMB, WHALE GUN	ARMAMENT-AMMUNITION
BONNET, RAIN	CLOTHING-HEADWEAR
BOOBLEJOCK	WOODWORKING T&E
BOOK, DOCKET	DOCUMENTARY ARTIFACT
BOOK, LETTER COPY	DOCUMENTARY ARTIFACT
BOOK, MUSIC	DOCUMENTARY ARTIFACT
BOOK, PRAYER	DOCUMENTARY ARTIFACT
BOOK, RECIPE	DOCUMENTARY ARTIFACT
BOOK, RECORD	DOCUMENTARY ARTIFACT
BOOK, TICKET	EXCHANGE MEDIUM
BOOM	WATER TRANSP.-ACCESSORY
BOTTLE, BEER	MERCHANDISING T&E
BOTTLE, CHRISTENING	CEREMONIAL ARTIFACT
BOTTLE, FOODSTUFF	MERCHANDISING T&E
BOTTLE, INK	MERCHANDISING T&E
BOTTLE, LIQUOR	MERCHANDISING T&E
BOTTLE, MILK	MERCHANDISING T&E
BOTTLE, OIL	ARMAMENT-ACCESSORY
BOTTLE, PESTICIDE	MERCHANDISING T&E
BOTTLE, SAMPLE	MINING & MINERAL HARVESTING
BOTTLE, SELTZER	FOOD SERVICE T&E
BOTTLE, SPRAY	MAINTENANCE T&E
BOTTLE, WINE	MERCHANDISING T&E

NATIONAL PARK SERVICE
1993 SUPPLEMENTARY HISTORY OBJECT TERM LIST

OBJECT TERM AND MODIFIER	CLASSIFICATION
BOX, ALMS	CEREMONIAL ARTIFACT
BOX, BAIT	FISHING & TRAPPING T&E
BOX, CIGAR	MERCHANDISING T&E
BOX, FAKING	WATER TRANSP.-ACCESSORY
BOX, FOODSTUFF	MERCHANDISING T&E
BOX, FRUIT	MERCHANDISING T&E
BOX, KITCHEN	FOOD SERVICE T&E
BOX, LEAD	DRAFTING T&E
BOX, MAP	MERCHANDISING T&E
BOX, MEDICINE	MERCHANDISING T&E
BOX, NAIL	WOODWORKING T&E
BOX, NET	FISHING & TRAPPING T&E
BOX, PAINT	MERCHANDISING T&E
BOX, PESTICIDE	MERCHANDISING T&E
BOX, SEWING	TEXTILEWORKING T&E
BOX, SHOE	MERCHANDISING T&E
BOX, SPIT	HOUSEHOLD ACCESSORY
BOX, THREAD	TEXTILEWORKING T&E
BOX, TOILETRY	MERCHANDISING T&E
BOX, TOY	MERCHANDISING T&E
BRACE, BAND	WATER TRANSP.-ACCESSORY
BRASSARD	PERSONAL SYMBOL
BREASTHOOK	WATER TRANSP.-ACCESSORY
BRUSH, FIREPLACE	TEMPERATURE CONTROL DEVICE
BRUSH, LENS	PHOTOGRAPHIC T&E
BRUSH, RAZOR	TOILET ARTICLE
BUCKET, BAIT	FISHING & TRAPPING T&E
BUCKET, WELL	HOUSEHOLD ACCESSORY
BULB, FLASH	PHOTOGRAPHIC T&E
BULLETIN	DOCUMENTARY ARTIFACT
BULLSEYE	WATER TRANSP.-ACCESSORY
BULWARK	WATER TRANSP.-ACCESSORY
BURNER	FOOD PROCESSING T&E
BUSK	CLOTHING, UNDERWEAR
BUTTPLATE	ARMAMENT-FIREARM
CACHET	DOCUMENTARY ARTIFACT
CAMEO	ART
CAN, AEROSOL	MERCHANDISING T&E
CAN, COFFEE	MERCHANDISING T&E
CAN, FILM	MERCHANDISING T&E
CAN, FOODSTUFF	MERCHANDISING T&E
CAN, GASOLINE	MERCHANDISING T&E
CAN, MEDICINE	MERCHANDISING T&E
CAN, PESTICIDE	MERCHANDISING T&E
CAN, TOBACCO	MERCHANDISING T&E
CAN, TOILETRY	MERCHANDISING T&E

NATIONAL PARK SERVICE
1993 SUPPLEMENTARY HISTORY OBJECT TERM LIST

OBJECT TERM AND MODIFIER	CLASSIFICATION
CANISTER	ARMAMENT-AMMUNITION
CAP, RIDGE	BUILDING COMPONENT
CARBURETOR	ENERGY PRODUCTION T&E
CARD	WRITTEN COMMUNICATION T&E
CARD, AWARD	DOCUMENTARY ARTIFACT
CARD, DISPLAY	ADVERTISING MEDIUM
CARTRIDGE	ARMAMENT AMMUNITION
CARTRIDGE, INK	WRITTEN COMMUNICATION T&E
CASE, ALTIMETER	SURVEYING & NAVIGATION T&E
CASE, AMMUNITION	ARMAMENT-ACCESSORY
CASE, AWARD	DOCUMENTARY ARTIFACT
CASE, BANJO	MUSICAL T&E
CASE, BOBBIN	TEXTILEWORKING T&E
CASE, BOLSTER	BEDDING
CASE, BOW	ARMAMENT-ACCESSORY
CASE, CUP	PERSONAL GEAR
CASE, GLOVE	CLOTHING ACCESSORY
CASE, MAILING	CONTAINER
CASE, MAP	WRITTEN COMMUNICATION T&E
CASE, SHOULDER KNOT	PERSONAL GEAR
CASE, SLIDE TRANSPARENCY	DOCUMENTARY ARTIFACT
CASE, VACUUM BOTTLE	MERCHANDISING T&E
CASE, WAFER	WRITTEN COMMUNICATION T&E
CASSETTE, AUDIOTAPE	DOCUMENTARY ARTIFACT
CASSETTE, VIDEOTAPE	DOCUMENTARY ARTIFACT
CAST	MEDICAL & PSYCHOLOGICAL T&E
CATCHER, GRASS	AGRICULTURAL T&E
CERTIFICATE	DOCUMENTARY ARTIFACT
CHAIR, CHIROPODY	MEDICAL & PSYCHOLOGICAL T&E
CHARCOAL	ENERGY PRODUCTION T&E
CHART	DOCUMENTARY ARTIFACT
CHART, INSTRUCTIONAL	DOCUMENTARY ARTIFACT
CHART, ORGANIZATIONAL	DOCUMENTARY ARTIFACT
CHECK, BAGGAGE	WRITTEN COMMUNICATION T&E
CHECKBOOK	DOCUMENTARY ARTIFACT
CHEMICAL	CHEMICAL T&E
CHINK, IRON	FOOD PROCESSING T&E
CHINKING	BUILDING COMPONENT
CHISEL, COLD	METALWORKING T&E
CLAMP, ALLIGATOR	ELECTRICAL & MAGNETIC T&E
CLAMP, HOSE	LAND TRANSP.-ACCESSORY
CLEANER, HEARING AID	PERSONAL GEAR
CLEANER, PHONOGRAPH RECORD	SOUND COMMUNICATION T&E
CLEANER, SHRIMP	FOOD PROCESSING T&E
CLEW	WATER TRANSP.-ACCESSORY
CLIP	MULTIPLE USE ARTIFACTS

NATIONAL PARK SERVICE
1993 SUPPLEMENTARY HISTORY OBJECT TERM LIST

OBJECT TERM AND MODIFIER	CLASSIFICATION
CLIP, STRIPPER	ARMAMENT-AMMUNITION
CLIPPERS	AGRICULTURAL T&E
CLIPPING, JOURNAL	DOCUMENTARY ARTIFACT
CLIPPING, MAGAZINE	DOCUMENTARY ARTIFACT
CLIPPING, NEWSPAPER	DOCUMENTARY ARTIFACT
CLOTH, POLISHING	MAINTENANCE T&E
CLUB, FISH	FISHING & TRAPPING T&E
CLUBHORSE	WATER TRANSP.-ACCESSORY
COAL	ENERGY PRODUCTION T&E
COAT, BLANKET	CLOTHING, OUTERWEAR
COAT, SUIT	CLOTHING, OUTERWEAR
COGWHEEL	TIMEKEEPING T&E
COIL, INDUCTION	ELECTRICAL & MAGNETIC T&E
COLLAR, PARRAL	WATER TRANSP.-ACCESSORY
CONTAINER, MISSILE	ARMAMENT-ACCESSORY
COOLER, FOODSTUFF	FOOD PROCESSING T&E
CORBEL	BUILDING COMPONENT
CORD	ELECTRICAL & MAGNETIC T&E
CORD, DRUM	MUSICAL T&E
CORK	ARTIFACT REMNANT
CORONA	LAND TRANSP.-ACCESSORY
COT, BATH	FURNITURE
COUPLING, SHAFT	ENERGY PRODUCTION T&E
COVER, AIR CONDITIONER	TEMPERATURE CONTROL DEVICE
COVER, CANTEEN	PERSONAL GEAR
COVER, CARTRIDGE BOX	ARMAMENT-ACCESSORY
COVER, DUST	ARMAMENT-ACCESSORY
COVER, ELECTRICAL OUTLET	ELECTRICAL & MAGNETIC T&E
COVER, HAWSE	WATER TRANSP.- ACCESSORY
COVER, HOUSING	LAND TRANSP.-ACCESSORY
COVER, IRONING BOARD	MAINTENANCE T&E
COVER, PAPER FOLDER SET	WRITTEN COMMUNICATION T&E
COVER, PHOTOGRAPHIC PRINT	DOCUMENTARY ARTIFACT
COVER, PICTURE	ART
COVER, QUILT	BEDDING
COVER, SADDLE	LAND TRANSP.-ACCESSORY
COVER, SEA CHEST	PERSONAL GEAR
COVER, TOILET SEAT	HOUSEHOLD ACCESSORY
COVER, TYPEWRITER	WRITTEN COMMUNICATION T&E
COVER, WALLMOUNT	BUILDING COMPONENT
COVER, WINDOW	WATER TRANSP.-ACCESSORY
CRAMPON	SPORTS EQUIPMENT
CRANK	MULTIPLE USE ARTIFACTS
CRATE	MERCHANDISING T&E
CRATE, FOODSTUFF	MERCHANDISING T&E
CRATE, FRUIT	MERCHANDISING T&E

NATIONAL PARK SERVICE
1993 SUPPLEMENTARY HISTORY OBJECT TERM LIST

OBJECT TERM AND MODIFIER	CLASSIFICATION
CRATE, LIQUOR	MERCHANDISING T&E
CROCK, CONDIMENT	MERCHANDISING T&E
CROSSBAR	LAND TRANSP.-ACCESSORY
CUP, DESSERT	FOOD SERVICE T&E
CUTTER, BRUSH	AGRICULTURAL T&E
CUTTER, SOD	AGRICULTURAL T&E
CYLINDER	ENERGY PRODUCTION T&E
CYLINDER, KINETOPHONE	SOUND COMMUNICATION EQ
DAMPER	TEMPERATURE CONTROL DEVICE
DECLARATION	DOCUMENTARY ARTIFACT
DETECTOR, METAL	MINING & MINERAL HARVESTING
DIASCOPE	VISUAL COMMUNICATION T&E
DIFFERENTIAL	ENERGY PRODUCTION
DIRECTORY	DOCUMENTARY ARTIFACT
DISC	CHEMICAL T&E
DISC, DIGITAL	SOUND COMMUNICATION EQ
DISC, PHONOGRAPH	SOUND COMMUNICATION T&E
DISH, ICE	FOOD PROCESSING T&E
DISK	FUNCTION UNKNOWN
DISPENSER, COIN	MERCHANDISING T&E
DISPENSER, PAPER	MERCHANDISING T&E
DIVIDER, CARD	WRITTEN COMMUNICATION T&E
DIVIDER, FILE	WRITTEN COMMUNICATION EQ
DIVIDER, ROOM	BUILDING COMPONENT
DOCUMENT, LEGAL	DOCUMENTARY ARTIFACT
DOOR, SLIDING	BUILDING COMPONENT
DRAG	LAND TRANSP.-ACCESSORY
DRAWER	FURNITURE
DRIFTBOLT	WATER TRANSP.-ACCESSORY
DROPLIGHT	LIGHTING DEVICE
DRYER, GLOVE	CLOTHING-ACCESSORY
ELECTROSCOPE	ELECTRICAL & MAGNETIC T&E
ENGINE, ROCKET	AEROSPACE TRANSP.-ACCESSORY
EXPANDER	METALWORKING T&E
EYE	TEXTILEWORKING T&E
EYE, SERVED WIRE	WATER TRANSP.-ACCESSORY
EYEGASSES, PROTECTIVE	PERSONAL GEAR
EYEPLATE, PAD	WATER TRANSP.-ACCESSORY
FANCYWORK	ART
FASTENER, GUY	ELECTRICAL & MAGNETIC T&E
FASTENER, PAPER	WRITTEN COMMUNICATION T&E
FASTENING	WATER TRANSP.-ACCESSORY
FAUCHARD	ARMAMENT-EDGED
FERRULE	BUILDING COMPONENT
FILMSTRIP	DOCUMENTARY ARTIFACT
FILTER, AIR	PHOTOGRAPHIC T&E

NATIONAL PARK SERVICE
1993 SUPPLEMENTARY HISTORY OBJECT TERM LIST

OBJECT TERM AND MODIFIER	CLASSIFICATION
FILTER, COFFEE	FOOD PROCESSING T&E
FITTING, BOOM	WATER TRANSP.-ACCESSORY
FITTING, GREASE	METALWORKING T&E
FITTING, LEG	FURNITURE
FLANGE, HEAD SCUPPER	WATER TRANSP.-ACCESSORY
FLASHER	MECHANICAL T&E
FLASHING	BUILDING COMPONENT
FLOOR	BUILDING COMPONENT
FLORA, PRESSED	ART
FLYER	DOCUMENTARY ARTIFACT
FOIL, PHONOGRAPH	SOUND COMMUNICATION EQ
FOLDER	DOCUMENTARY ARTIFACT
FOLDER, PAPER	OTHER T&E FOR MATERIALS
FOODSTUFF	FOOD T&E
FOOTREST	LAND TRANSP.-ACCESSORY
FORELOCK	WATER TRANSP.-ACCESSORY
FORK, BARBECUE	FOOD PROCESSING T&E
FORM	DOCUMENTARY ARTIFACT
FORM, ARCH	MASONRY & STONEMWORKING T&E
FORM, SLEEVE	TEXTILEWORKING T&E
FRAME	WATER TRANSP.-ACCESSORY
FRAME, MIRROR	FURNITURE
FRETWORK	WATER TRANSP.-ACCESSORY
FUSE	ELECTRICAL & MAGNETIC T&E
GASKET	WATER TRANSP.-ACCESSORY
GAUGE, TEMPERATURE	LAND TRANSP.-MOTORIZED
GAVEL	PERSONAL SYMBOL
GEAR	MECHANICAL T&E
GLASS, WINDOW	BUILDING COMPONENT
GLOVE, EXAMINATION	MEDICAL & PSYCHOLOGICAL T&E
GOOSE	TEXTILEWORKING T&E
GRATING	WATER TRANSP.-ACCESSORY
GRINDER, FOOD	FOOD PROCESSING T&E
GUARD	ANIMAL HUSBANDRY T&E
GUARD, LEG	ARMAMENT-ACCESSORY
GUIDE, SAW SHARPENING	METALWORKING T&E
GUN, BARREL	ARMAMENT-FIREARM
GUN, PNEUMATIC	ARMAMENT-FIREARM
GUN, RAPID FIRE	ARMAMENT-ARTILLERY
GUN, SPEAR	FISHING & TRAPPING T&E
GUN, WALL	ARMAMENT-FIREARM
GUNFLINT	ARMAMENT-ACCESSORY
GUNPOWDER	ARMAMENT-AMMUNITION
GUTTER	BUILDING COMPONENT
GUY	BUILDING COMPONENT
HAMMER, ADZ EYE	WOODWORKING T&E

NATIONAL PARK SERVICE
1993 SUPPLEMENTARY HISTORY OBJECT TERM LIST

OBJECT TERM AND MODIFIER	CLASSIFICATION
HAMMER, ENGINEER'S	METALWORKING T&E
HANDLE	FUNCTION UNKNOWN
HANGER, COMB	PERSONAL GEAR
HANGER, ORNAMENT	HOUSEHOLD ACCESSORY
HANGER, PANTS	HOUSEHOLD ACCESSORY
HANGER, PLANT	HOUSEHOLD ACCESSORY
HANGER, PLATE	HOUSEHOLD ACCESSORY
HANGER, SKIRT	HOUSEHOLD ACCESSORY
HANK, JIB	WATER TRANSP.-ACCESSORY
HARDWARE, WAGON	LAND TRANSP.-ACCESSORY
HARNESS, RATION CART	LAND TRANSP.-ACCESSORY
HAT, CAMPAIGN	CLOTHING-HEADWEAR
HAT, UNIFORM	CLOTHING-HEADWEAR
HAWSE	WATER TRANSP.-ACCESSORY
HEART	WATER TRANSP.-ACCESSORY
HEATER, GAS	TEMPERATURE CONTROL DEVICE
HEATER, KEROSENE	TEMPERATURE CONTROL DEVICE
HITCH, TRAILER	LAND TRANSP.-MOTORIZED
HOLDER, BEVERAGE	FOOD SERVICE T&E
HOLDER, BUTTONHOOK	CLOTHING-ACCESSORY
HOLDER, CARD	GAME
HOLDER, CHALK	WRITTEN COMMUNICATION T&E
HOLDER, COASTER	FOOD SERVICE T&E
HOLDER, CORN	FOOD SERVICE T&E
HOLDER, CUP	FOOD SERVICE T&E
HOLDER, FILM AND PLATE	PHOTOGRAPHIC T&E
HOLDER, FISHING LINE	FISHING & TRAPPING T&E
HOLDER, LABEL	WRITTEN, COMMUNICATION T&E
HOLDER, LANTERN SLIDE	VISUAL COMMUNICATION T&E
HOLDER, LAST	LEATHER, HORN, SHELLWORKING
HOLDER, LETTER	WRITTEN COMMUNICATION T&E
HOLDER, MESSAGE	WRITTEN COMMUNICATION EQ
HOLDER, NAME CARD	WRITTEN COMMUNICATION T&E
HOLDER, PAPER	WRITTEN COMMUNICATION T&E
HOLDER, SHOT GLASS	FOOD SERVICE T&E
HOLDER, SOUFFLE DISH	FOOD SERVICE T&E
HOOD, LENS	PHOTOGRAPHIC T&E
HOOK AND EYE	CLOTHING-ACCESSORY
HOOK, CARGO	WATER TRANSP.-ACCESSORY
HOOK, CHAIN	WATER TRANSP.-ACCESSORY
HOOK, CLOTHES	HOUSEHOLD ACCESSORY
HOOK, CONNECTING	OTHER T&E FOR MATERIALS
HOOK, FIREPLACE	FOOD PROCESSING T&E
HOOK, PELICAN	OTHER T&E FOR MATERIALS
HOOK, PINTLE	ARMAMENT-ACCESSORY
HOOK, POT	FOOD PROCESSING T&E

NATIONAL PARK SERVICE
1993 SUPPLEMENTARY HISTORY OBJECT TERM LIST

OBJECT TERM AND MODIFIER	CLASSIFICATION
HOOK, S	MULTIPLE USE ARTIFACTS
HOOK, SISTER	WATER TRANSP.-ACCESSORY
HOOK, STOPPER	WATER TRANSP.-ACCESSORY
HOOK, SWAY	WATER TRANSP.-ACCESSORY
HOOK, SWIVEL	WATER TRANSP.-ACCESSORY
HOOK, TAFFRAIL	WATER TRANSP.-ACCESSORY
HOOK, TURF	AGRICULTURAL T&E
HOOP, SKIRT	CLOTHING-UNDERWEAR
HOOP, TOPMOST	WATER TRANSP.-ACCESSORY
HOPPER	AGRICULTURAL T&E
HORSE, STITCHING	LEATHER, HORN, SHELLWORKING
HOSE	LAND TRANSP.-ACCESSORY
HOSE, AIR	OTHER T&E FOR SCI. & TECH.
HOSE, ENEMA	MEDICAL & PSYCHOLOGICAL T&E
HOSE, GARDEN	AGRICULTURAL T&E
HUBCAP	LAND TRANSP.-ACCESSORY
HULL	WATER TRANSP.-EQUIPMENT
HUSK, SOUVENIR	DOCUMENTARY ARTIFACT
ICON	CEREMONIAL ARTIFACT
ILLUMINATOR	VISUAL COMMUNICATION T&E
INDICATOR, HORSEPOWER	WATER TRANSP.-ACCESSORY
INDICATOR, STEAM	MECHANICAL T&E
INSIGNIA	PERSONAL SYMBOL
INSTRUCTIONS	DOCUMENTARY ARTIFACT
INSTRUMENT, CENTERING	WOODWORKING T&E
INSULATION	BUILDING COMPONENT
INTERFACING	TEXTILEWORKING T&E
IRON, BOAT	WOODWORKING T&E
IRON, CRIMPING	TEXTILEWORKING T&E
IRON, SHARP	WOODWORKING T&E
IRON, TIRE	LAND TRANSP.-ACCESSORY
ITINERARY	DOCUMENTARY ARTIFACT
JACK, PUMP	SITE FEATURE
JACK, TELEPHONE	TELECOMMUNICATION T&E
JACKET, PHONOGRAPH RECORD	SOUND COMMUNICATION T&E
JAR, FOODSTUFF	MERCHANDISING T&E
JAR, MEDICINE	MERCHANDISING T&E
JAR, TOILETRY	MERCHANDISING T&E
JOINT, UNIVERSAL	ENERGY PRODUCTION T&E
JOIST	BUILDING COMPONENT
JOLLY, BEACH	WATER TRANSP.-EQUIPMENT
JUG, FUEL	MERCHANDISING T&E
KEEL	WATER TRANSP.-EQUIPMENT
KEELSON	WATER TRANSP.-EQUIPMENT
KIT, REPAIR	ARMAMENT-ACCESSORY
KIT, SAILMAKER'S NEEDLE	TEXTILEWORKING T&E

NATIONAL PARK SERVICE
1993 SUPPLEMENTARY HISTORY OBJECT TERM LIST

OBJECT TERM AND MODIFIER	CLASSIFICATION
KNEE	WATER TRANSP.-ACCESSORY
KNIFE, BLEEDING	ANIMAL HUSBANDRY T&E
KNIFE, CARPET	TEXTILEWORKING T&E
KNIFE, SCALING	FOOD PROCESSING T&E
KNIGHTHEAD	WATER TRANSP.-ACCESSORY
KNOB	FURNITURE
LABEL, LINEN	TEXTILEWORKING T&E
LABEL, PROPERTY	DOCUMENTARY ARTIFACT
LABEL, SHIPPING	DOCUMENTARY ARTIFACT
LACE	ART
LAG	OTHER T&E FOR MATERIALS
LAMP, AUTOMOBILE	LAND TRANSP.-ACCESSORY
LAMP, FLAME SAFETY	WATER TRANSP.-ACCESSORY
LAMP, SUN	MEDICAL & PSYCHOLOGICAL T&E
LANTERN, CARBIDE	MINING & MINERAL HARVESTING
LAST, SADDLE	LEATHER, HORN, SHELLWORKING
LATTICE	BUILDING COMPONENT
LAUNCHER, PYROTECHNIC	VISUAL COMMUNICATION T&E
LAUNCHER, ROCKET	ARMAMENT-ARTILLERY
LAUNCHER, TARGET	ARMAMENT-ACCESSORY
LAZY SUSAN	FOOD SERVICE T&E
LEAD	METALWORKING T&E
LENS, RANGE LIGHT	OPTICAL T&E
LETTER, FORM	ADVERTISING MEDIUM
LID	FUNCTION UNKNOWN
LIFTER, HAT BOX	MERCHANDISING T&E
LINE, DRIVE	ENERGY PRODUCTION T&E
LINE, STEAM	ENERGY PRODUCTION T&E
LINK	WATER TRANSP.-ACCESSORY
LINOLEUM	FLOOR COVERING
LITHOPHANE	ART
LIZARD	WATER TRANSP.-ACCESSORY
LOCKER	HOUSEHOLD ACCESSORY
LOOP, HONDA	AGRICULTURAL T&E
LOOP, MAST	WATER TRANSP.-ACCESSORY
MACHINE, DEPTH-GAUGE	SOUND COMMUNICATION T&E
MACHINE, RECORDING	SOUND COMMUNICATION T&E
MACHINE, STENCIL	WRITTEN COMMUNICATION EQ
MACHINE, TICKET PUNCH	MERCHANDISING T&E
MANDREL, PHONOGRAPH	SOUND COMMUNICATION T&E
MANUSCRIPT, MUSIC	DOCUMENTARY ARTIFACT
MAQUETTE	ART
MARKER	AGRICULTURAL T&E
MARKER, BOUNDARY	SURVEYING & NAVIGATIONAL T&E
MARKER, PATTERN	TEXTILEWORKING T&E
MASK, DIVER'S	WATER TRANSP.-ACCESSORY

NATIONAL PARK SERVICE
1993 SUPPLEMENTARY HISTORY OBJECT TERM LIST

OBJECT TERM AND MODIFIER	CLASSIFICATION
MASK, LIFE	ART
MAST	WATER TRANSP.-ACCESSORY
MAT, STOVE	FLOOR COVERING
MATTE	ART
MEASURE, PHARMACEUTICAL	MEDICAL & PSYCHOLOGICAL T&E
MEDICINE	MEDICAL & PSYCHOLOGICAL T&E
METER, GAS	MECHANICAL T&E
MILL, GRAIN	FOOD PROCESSING T&E
MIMEOSCOPE	PHOTOGRAPHIC T&E
MINUTES, MEETING	DOCUMENTARY ARTIFACT
MITT, BATH	TOILET ARTICLE
MODEL	ART
MODEL, EXHIBIT	OTHER T&E FOR COMMUNICATION
MOLD, DOUGHNUT	FOOD PROCESSING T&E
MOLDING	BUILDING COMPONENT
MONITOR, VIDEO	TELECOMMUNICATIONS T&E
MOUNT, ENGINE	ENERGY PRODUCTION T&E
NECKPIECE	CLOTHING-ACCESSORY
NIGHT-LIGHT	LIGHTING DEVICE
NOGGING	BUILDING COMPONENT
NOTE	DOCUMENTARY ARTIFACT
OATH	DOCUMENTARY ARTIFACT
OIL, LATHE	METALWORKING T&E
OIL, NEAT'S-FOOT	LEATHER, HORN, SHELLWORKING
OINTMENT, ANTI-GAS	OTHER T&E FOR SCI. & TECH.
ORDER, PAY	DOCUMENTARY ARTIFACT
ORDER, SHIPPING	DOCUMENTARY ARTIFACT
ORGANIZER, DESK	WRITTEN COMMUNICATION T&E
ORNAMENT	ART
ORNAMENT, HARNESS	LAND TRANSP.-ACCESSORY
ORNAMENT, HOLIDAY	ART
ORNAMENT, PARTY	ART
PACKET, FOODSTUFF	MERCHANDISING T&E
PACKET, PESTICIDE	MERCHANDISING T&E
PAD, SCOURING	MAINTENANCE T&E
PANELING	WATER TRANSP.-ACCESSORY
PAPER FRAGMENT	ARTIFACT REMNANT
PAPER, CARBON	WRITTEN COMMUNICATION EQ
PAPER, CIGARETTE	PERSONAL GEAR
PAPER, NEEDLE	MERCHANDISING T&E
PAPER, PINS	MERCHANDISING T&E
PAPER, ROOFING	BUILDING COMPONENT
PAPER, WAX	MERCHANDISING T&E
PASS, BOARDING	DOCUMENTARY ARTIFACT
PAVEMENT	SITE FEATURE
PELORUS	SURVEYING & NAVIGATIONAL T&E

NATIONAL PARK SERVICE
1993 SUPPLEMENTARY HISTORY OBJECT TERM LIST

OBJECT TERM AND MODIFIER	CLASSIFICATION
PENCIL/PEN	WRITTEN COMMUNICATION T&E
PHONOGRAPH, CYLINDER	SOUND COMMUNICATION T&E
PHONOGRAPH, DISC	SOUND COMMUNICATION T&E
PHONOGRAPH, FOIL	SOUND COMMUNICATION EQ
PICK, FLORIST'S	OTHER T&E FOR MATERIALS
PICK, GUITAR	MUSICAL T&E
PICK, HORS D'OEUVRE	FOOD SERVICE T&E
PICTURE, BEADED	ART
PICTURE, FEATHER	ART
PILL	MEDICAL & PSYCHOLOGICAL T&E
PIN, AWARD	PERSONAL SYMBOL
PIN, HALYARD	WATER TRANSP.-ACCESSORY
PIN, HINGE	WATER TRANSP.-ACCESSORY
PIN, INSIGNIA	PERSONAL SYMBOL
PIN, INSULATOR	ELECTRICAL & MAGNETIC T&E
PIN, PICKET	ANIMAL HUSBANDRY T&E
PIN, PIVOT	WATER TRANSP.-ACCESSORY
PIN, SHACKLE	WATER TRANSP.-ACCESSORY
PIN, TACK	WATER TRANSP.-ACCESSORY
PINRAIL	WATER TRANSP.-ACCESSORY
PIPE	WATER TRANSP.-ACCESSORY
PIPE, EXHAUST	ENERGY PRODUCTION T&E
PIPE, FOOTING	METALWORKING T&E
PIPE, SCUPPER	WATER TRANSP.-ACCESSORY
PISTOL, LINE-THROWING	ARMAMENT-FIREARM
PISTOL, SHOT	ARMAMENT-FIREARM
PLAN	DOCUMENTARY ARTIFACT
PLANE, TROLLING	FISHING & TRAPPING T&E
PLANKING	WATER TRANSP.-ACCESSORY
PLASTER	MEDICAL & PSYCHOLOGICAL T&E
PLASTIC FRAGMENT	ARTIFACT REMNANT
PLATE, BUILDER'S	DOCUMENTARY ARTIFACT
PLATE, ELECTROTYPE	PRINTING T&E
PLATE, ENGINE	ENERGY PRODUCTION T&E
PLATE, SPECIFICATION	MINING T&E
PLATE, SWITCH	BUILDING COMPONENT
PLATE, TIE	RAIL TRANSPORTATION, ACCESSORY
PLATE, WARMING	FOOD PROCESSING T&E
PLAYER, DIGITAL DISC	SOUND COMMUNICATION EQ
PLINTH	ART
PLOW, EVENER	METALWORKING T&E
PLOW, TWO-WAY	AGRICULTURAL T&E
PLUG	SOUND COMMUNICATION T&E
POLISH, STOVE	MAINTENANCE T&E
POMPON	PERSONAL SYMBOL
PORTHOLE	WATER TRANSP.-ACCESSORY

NATIONAL PARK SERVICE
1993 SUPPLEMENTARY HISTORY OBJECT TERM LIST

OBJECT TERM AND MODIFIER	CLASSIFICATION
POST, BINDING	ELECTRICAL & MAGNETIC T&E
POWDER, ANTI-DIMMING	OTHER T&E FOR SCI. & TECH.
PRESCRIPTION	DOCUMENTARY ARTIFACT
PRESS, COOKIE	FOOD PROCESSING T&E
PRESS, MEAT	FOOD PROCESSING T&E
PRESS, TENNIS RACKET	SPORTS EQUIPMENT
PRESS, WAFER	CEREMONIAL ARTIFACT
PRICKER, SAILMAKER'S	TEXTILEWORKING T&E
PRISM, DECK	WATER TRANSP.-ACCESSORY
PROCLAMATION	DOCUMENTARY ARTIFACT
PROJECTOR/PHONOGRAPH	OTHER T&E FOR COMMUNICATION
PROPELLANT	ARMAMENT-ACCESSORY
PROTECTOR, DOCUMENT	WRITTEN COMMUNICATION T&E
PULASKI	FORESTRY T&E
PULL	FURNITURE
PULLER, GEAR	MECHANICAL T&E
PULLER, SLATE	MASONRY & STONEMWORKING T&E
PULLEY, EXERCISE	SPORTS EQUIPMENT
PUMP, DIVER'S	OTHER T&E FOR SCI. & TECH.
PUMP, FLOAT	WATER TRANSP.-ACCESSORY
PUMP, FUEL	SITE FEATURE
PUMP, PLUNGER	WATER TRANSP.-ACCESSORY
PUNCHEON	BUILDING COMPONENT
RACK, BICYCLE	LAND TRANSP.-ACCESSORY
RACK, CLOTHING	WATER TRANSP.-ACCESSORY
RACK, COMB	TOILET ARTICLE
RACK, CUP	HOUSEHOLD ACCESSORY
RACK, DAIRY	FOOD PROCESSING T&E
RACK, EQUIPMENT	SPORTS EQUIPMENT
RACK, KNIFE	FOOD PROCESSING T&E
RACK, TIE	HOUSEHOLD ACCESSORY
RADIO/PHONOGRAPH	OTHER T&E FOR COMMUNICATION
RAIL	WATER TRANSP.-ACCESSORY
RAMROD	ARMAMENT-ACCESSORY
RAW MATERIAL (MATERIAL NAME)	APPROPRIATE CLASSIFICATION
RECORD, DICTATING MACHINE	SOUND COMMUNICATION T&E
REEL, FILM	PHOTOGRAPHIC T&E
REGISTER	DOCUMENTARY ARTIFACT
REGULATOR, NATURAL GAS	MERCHANDISING T&E
RELEASE, HYDROSTATIC	WATER TRANSP.-ACCESSORY
RELIC, HISTORIC	DOCUMENTARY ARTIFACT
RELIEF	ART
REMOVER, INK	WRITTEN COMMUNICATION T&E
REPORT	DOCUMENTARY ARTIFACT
REQUISITION	DOCUMENTARY ARTIFACT
RESIDUE	CHEMICAL T&E

NATIONAL PARK SERVICE
1993 SUPPLEMENTARY HISTORY OBJECT TERM LIST

OBJECT TERM AND MODIFIER	CLASSIFICATION
REST, PEN	WRITTEN COMMUNICATION T&E
RESUME	DOCUMENTARY ARTIFACT
RETABLO	CEREMONIAL ARTIFACT
RIFLE, ASSAULT	ARMAMENT-FIREARM
RIFLE, SPOTTING	ARMAMENT-FIREARM
RIFLE, TRAINING	ARMAMENT-FIREARM
RING, DRAPERY	WINDOW OR DOOR COVERING
ROD	MECHANICAL T&E
ROD, CONNECTING	OTHER T&E FOR MATERIALS
ROD, DRAPERY	WINDOW OR DOOR COVERING
ROLLER, PAPER	MERCHANDISING T&E
ROOF	BUILDING COMPONENT
ROUGE, JEWELER'S	OTHER T&E FOR MATERIALS
RUBBER, SAILMAKER'S	TEXTILEWORKING T&E
SCOOP, COFFEE	FOOD SERVICE T&E
SCOREPAD	DOCUMENTARY ARTIFACT
SCRAPER, FLOOR	ANIMAL HUSBANDRY T&E
SCRAPER, ICE	MULTIPLE USE ARTIFACTS
SCUPPER	WATER TRANSP.-ACCESSORY
SEAL, COMPANY	WRITTEN COMMUNICATION T&E
SEAL, SECURITY	MERCHANDISING T&E
SEALER, HEAT	MERCHANDISING T&E
SEMICONDUCTOR	ELECTRICAL & MAGNETIC T&E
SET, DECANter	FOOD SERVICE T&E
SET, PAINT	PAINTING T&E
SET, RIVET	METALWORKING T&E
SETScrew	METALWORKING T&E
SHAFT, DRIVE	LAND TRANSP.-ACCESSORY
SHEATH, FID	TEXTILEWORKING T&E
SHEATH, MINcing KNIFE	FISHING & TRAPPING T&E
SHEAVE	WATER TRANSP.-ACCESSORY
SHELLER, NUT	FOOD PROCESSING T&E
SHIELD, ERASING	DRAFTING T&E
SHOE, DIVER'S	PERSONAL GEAR
SHUFFLER, CARD	GAME
SIDING	BUILDING COMPONENT
SIGN, IDENTIFICATION	VISUAL COMMUNICATION T&E
SIGN, WARNING	VISUAL COMMUNICATION T&E
SLED, DOG	LAND TRANSP.-ANIMAL-POWERED
SLEEVE, PHONOGRAPH RECORD	MERCHANDISING T&E
SLICER, EGG	FOOD PROCESSING T&E
SLIP, BANK DEPOSIT	DOCUMENTARY ARTIFACT
SNAP	CLOTHING ACCESSORY
SOCKET	METALWORKING T&E
SORTER, CRANBERRY	AGRICULTURAL T&E
SORTER, WIRE	METALWORKING T&E

NATIONAL PARK SERVICE
1993 SUPPLEMENTARY HISTORY OBJECT TERM LIST

OBJECT TERM AND MODIFIER	CLASSIFICATION
SPAR	WATER TRANSP.-ACCESSORY
SPARKPLUG	ENERGY PRODUCTION T&E
SPIKE, HAWSE	WATER TRANSP.-ACCESSORY
SPONGE	HOUSEHOLD ACCESSORY
SPREADER	WATER TRANSP.-ACCESSORY
SPREADER, MINERAL	AGRICULTURAL T&E
SPREADER, ROPE	AGRICULTURAL T&E
SPRING	MECHANICAL T&E
SPRING, COIL	MECHANICAL T&E
SPRING, LEAF	MECHANICAL T&E
STAND	HOUSEHOLD ACCESSORY
STAND, CASSEROLE	FOOD SERVICE T&E
STAND, CHURN	FOOD PROCESSING T&E
STAND, DRUM	MUSICAL T&E
STAND, FLAG	CEREMONIAL ARTIFACT
STAND, MICROPHONE	SOUND COMMUNICATION T&E
STAND, PICTURE FRAME	HOUSEHOLD ACCESSORY
STAND, PLACECARD	HOUSEHOLD ACCESSORY
STAND, ROLLING PIN	FOOD PROCESSING T&E
STAND, SHOE REPAIR	OTHER T&E FOR MATERIALS
STAND, SHOESHINE	FURNITURE
STATEMENT	DOCUMENTARY ARTIFACT
STATEMENT, CUSTOMS	DOCUMENTARY ARTIFACT
STEELYARD	WEIGHTS & MEASURES T&E
STERN	WATER TRANSP.-EQUIPMENT
STERNPOST	WATER TRANSP.-ACCESSORY
STICK, LITTER PICKUP	MAINTENANCE T&E
STOCK (MATERIAL NAME)	APPROPRIATE CLASSIFICATION
STONE, MEMORIAL	CEREMONIAL ARTIFACT
STOOL, SWIVEL	WATER TRANSP.-ACCESSORY
STOVE, CHARCOAL	TEMPERATURE CONTROL DEVICE
STOVE, COAL	TEMPERATURE CONTROL DEVICE
STOVE, Kerosine	FOOD PROCESSING T&E
STOVE, OIL	TEMPERATURE CONTROL DEVICE
STRAW	FOOD SERVICE T&E
STRETCHER, PANTS	CLOTHING-ACCESSORY
STROP, BLOCK	WATER TRANSP.-ACCESSORY
STUD, CAMPAIGN	PERSONAL SYMBOL
SWEEPER, LAWN	AGRICULTURAL T&E
T-SQUARE/PROTRACTOR	DRAFTING T&E
TABLE, FOLDING	FURNITURE
TABLE, MASSAGE	MEDICAL & PSYCHOLOGICAL T&E
TABLET	WRITTEN COMMUNICATION T&E
TACK, CARPET	WOODWORKING T&E
TACK, UPHOLSTERY	TEXTILEWORKING T&E
TACKLE, FISHING	FISHING & TRAPPING T&E

NATIONAL PARK SERVICE
1993 SUPPLEMENTARY HISTORY OBJECT TERM LIST

OBJECT TERM AND MODIFIER	CLASSIFICATION
TAFFRAIL	WATER TRANSP.-ACCESSORY
TAG	DOCUMENTARY ARTIFACT
TAPE, PACKAGING	MULTIPLE USE ARTIFACTS
TAPE, REGISTER	MERCHANDISING T&E
TAPE, SEED	AGRICULTURAL T&E
TELEVISION	TELECOMMUNICATION T&E
TEXTILE FRAGMENT	ARTIFACT REMNANT
THREADER, PIPE	METALWORKING T&E
THRESHOLD	BUILDING COMPONENT
THUMB TACK	WRITTEN COMMUNICATION T&E
TICKET, RATION	EXCHANGE MEDIUM
TIE, BUNDLE	MERCHANDISING T&E
TIE, MASONRY	BUILDING COMPONENT
TIE, RAILROAD	RAIL TRANSP.-ACCESSORY
TIE, TWIST	MULTIPLE USE ARTIFACTS
TIN, FOODSTUFF	MERCHANDISING T&E
TIN, MEDICINE	MERCHANDISING T&E
TIN, POWDER	ARMAMENT-ACCESSORY
TIN, TOBACCO	MERCHANDISING T&E
TIN, TOILETRY	MERCHANDISING T&E
TONGS, CARGO	WATER TRANSP.-ACCESSORY
TONGS, PAPER	PHOTOGRAPHIC T&E
TOOL, COOPERING	WOODWORKING T&E
TOOL, CORNERING	WOODWORKING T&E
TOOL, ENTRENCHING	ARMAMENT-ACCESSORY
TOOL, PACKING	WATER TRANSP.-ACCESSORY
TOOL, POUCH	ARMAMENT-ACCESSORY
TOOL, PRIMING	ARMAMENT-ACCESSORY
TORTILLON	PAINTING T&E
TOWEL	TOILET ARTICLE
TRANSMISSION	ENERGY PRODUCTION T&E
TRANSOM	BUILDING COMPONENT
TRANSPARENCY	ART
TRAY, CARD	GAME
TRIDENT	CEREMONIAL ARTIFACT
TUB, FOODSTUFF	MERCHANDISING T&E
TUBE, TOILETRY	MERCHANDISING T&E
TUNER, MULTIPLEX	ACOUSTICAL T&E
TUYERE	METALWORKING T&E
TYPESCRIPT	DOCUMENTARY ARTIFACT
VALVE	FUNCTION UNKNOWN
VALVE, PRESSURE RELIEF	WATER TRANSP.-ACCESSORY
VENT, CAP	PLUMBING FIXTURE
VIBRATOR	MEDICAL & PSYCHOLOGICAL T&E
VOUCHER	DOCUMENTARY ARTIFACT
WAFER	WRITTEN COMMUNICATION T&E

NATIONAL PARK SERVICE
1993 SUPPLEMENTARY HISTORY OBJECT TERM LIST

OBJECT TERM AND MODIFIER	CLASSIFICATION
WALL	BUILDING COMPONENT
WAND	TOY
WAX	FOOD PROCESSING T&E
WAX, SAILMAKER'S	TEXTILEWORKING T&E
WAX, SKI	SPORTS EQUIPMENT
WAY, SHIPYARD	OTHER STRUCTURE
WEATHERSTRIP	TEMPERATURE CONTROL DEVICE
WEIGHT	LAND TRANSP.-ACCESSORY
WEIGHT, COUNTERBALANCE	FOOD PROCESSING T&E
WEIGHT, HITCHING	LAND TRANSP.-ACCESSORY
WHEELBOX	WATER TRANSP.-ACCESSORY
WHORL	TEXTILEWORKING T&E
WINDOW	WATER TRANSP.-ACCESSORY
WIRE, BALING	AGRICULTURAL T&E
WIRE, BARBED	AGRICULTURAL T&E
WIRE, CHICKEN	AGRICULTURAL T&E
WOOD FRAGMENT	ARTIFACT REMNANT
WORKSHEET	DOCUMENTARY ARTIFACT
YARD	WATER TRANSP.-ACCESSORY
YOKE, CONNECTING	MECHANICAL T&E

Appendix I: Lot Cataloging

	<u>Page</u>
A. General Rules for Lot Cataloging	I:1
What is lot cataloging?	I:1
When can I use lot cataloging?	I:1
When can't I use lot cataloging?.....	I:1
How many catalog numbers do I assign to a lot?	I:1
How do I count the lot?	I:1
Is there a limit on the size of a lot?	I:1
How do I number the objects in a lot?	I:1
What if I remove an object from the lot?.....	I:2
How do I store lot cataloged objects?.....	I:2
B. Discipline-specific Rules for Lot Cataloging Cultural Resources Collections	I:2
What are the discipline-specific rules for lot cataloging archeology objects?.....	I:2
What are the discipline-specific rules for lot cataloging ethnology objects?.....	I:3
What are the discipline-specific rules for lot cataloging history objects?.....	I:4
What are the discipline-specific rules for lot cataloging archives and manuscript collections?.....	I:4
C. Discipline-specific Rules for Lot Cataloging Natural History Collections	I:4
What are the rules for lot cataloging natural history collections?	I:4
How does lot cataloging relate to the research objectives of the collecting project?.....	I:5
Does lot cataloging vary from taxon to taxon?.....	I:5
What is the maximum allowable taxonomic diversity within a lot?	I:6
Are the procedures for lot cataloging natural history specimens different from cataloging specimens individually?	I:6
What do I do if I need to remove specimens from the lot?.....	I:7
What if specimens in a lot are recataloged?	I:7
D. List of Figures	I:8

APPENDIX I: LOT CATALOGING

A. General Rules for Lot Cataloging

- What is lot cataloging?*

Lot cataloging is a method of cataloging a group, or lot, of objects rather than cataloging them individually. It's a way to account for similar objects without having to catalog each individual item.
- When can I use lot cataloging?*

Use of lot cataloging depends on the subject discipline. See Sections B and C of this appendix for discipline-specific rules for lot cataloging. The items in the lot don't have to be identical. They do have to have certain common characteristics, such as the same accession number and object name.

See Figures I.1-I.5 for examples of lot cataloging.
- When can't I use lot cataloging?*

Don't use lot cataloging for:

 - rare or high value items
 - type specimens
 - objects that you need to individually track, such as those on incoming loan or exhibit
- How many catalog numbers do I assign to a lot?*

Assign one catalog number to the lot. Don't use component part designators with lots. Refer to Section I in Appendix C of this handbook for information on component parts.
- How do I count the lot?*

If possible, count the total number of items in the lot. Enter this number in the Item Count field in ANCS+. For lots that are too large or difficult to count, use the Quantity and Storage Unit fields for:

 - linear or cubic feet (for archives)
 - the number of storage containers, such as 4 boxes

Note: Many archeological collections include weight. Enter information on weight in the Weight field in ANCS+.
- Is there a limit on the size of a lot?*

No. It's a good idea to divide extremely large lots into verifiable units of measure for inventory purposes.
- How do I number the objects in a lot?*

<i>If there are...</i>	<i>Then...</i>
only a few objects,	you can mark the number on each object.
too many items to number individually,	number or label the containers.

Note: Don't use designators with the catalog number. Use designators only with component parts, pairs, and sets. Refer to Section I in Appendix C of this handbook for information on component parts, pairs, and sets.

8. *What if I remove an object from the lot?*

You may occasionally need to remove an object from the lot. For example, one item in a lot may go on exhibit or loan. There also may be items missing from the lot that you will have to deaccession.

When an object is separated from the lot, give it a new catalog number and a separate catalog record. Cross-reference both the new and original records to each other. Adjust the Item Count field on the original record to show that you have removed items from the lot.

9. *How do I store lot cataloged objects?*

Usually you store lots in a common container or containers that you store together in the same location.

B. Discipline-specific Rules for Lot Cataloging Cultural Resources Collections

1. *What are the discipline-specific rules for lot cataloging archeology objects?*

Archeology collections are frequently lot cataloged. To lot catalog archeology collections, the lot must:

- be from the same accession
- be from the same provenience (to the smallest level)
- be of the same material (or composite materials)
- have the same object name

Lots must be from the smallest provenience recorded by the archeologist. Within provenience, split objects into groups by material. You can't mix different materials in the same lot unless you classify the objects as composites.

Further divide lots by the specific material type that falls within a broader material category. For example, don't catalog chert, jasper, and obsidian projectile points from the same provenience as one lot. Although these materials are all stone, make separate lots for each specific material type. It's especially important to separate material types that the archeologist considers to be diagnostic.

You can use the object name to further separate lots:

- from the same provenience
- made from the same material

For example, you can make separate lots for rim sherds and body sherds.

Object names can be general, such as chipped stone, or specific, such as projectile point. Use only one object name per lot. For example, don't list several projectile point types as the object name.

Example:

Accession: Untyped sherds from Site 204, Kiva 1, fill and Kiva 1, floor

1 lot catalog record: Sherds, untyped (Site 204, Kiva 1, fill)

1 lot catalog record: Sherds, untyped (Site 204, Kiva 1, floor)

Accession: Miscellaneous ceramic and metal fragments, Jones House Site, Room 5, floor

1 lot catalog record: Chinese export porcelain fragments

1 lot catalog record: transfer printed whiteware fragments

1 lot catalog record: unidentified ferrous alloy fragments

1 lot catalog record: unidentified copper alloy fragments

2. *What are the discipline-specific rules for lot cataloging ethnology objects?*

Ethnology collections are usually not lot cataloged. To lot catalog ethnology collections, the lot must:

- be from the same accession
- be from the same provenience
- be from the same cultural group
- be from the same date/period
- have the same object name
- have the same artist/maker (if known)

The objects should be identical or similar.

Example:

Accession: Hopi and Navajo beads

1 lot catalog record: Hopi beads

1 lot catalog record: Navajo beads

Accession: 4 Comanche arrows

1 lot catalog record: Arrows (object name Arrow)

3. *What are the discipline-specific rules for lot cataloging history objects?*

History collections are usually not lot cataloged. To lot catalog history collections, the lot must:

- be from the same accession
- be from the same provenience
- be from the same date/period
- have the same object name
- have the same artist/maker (if known)
- have the same eminent figure (if any)

The objects should be identical or similar.

Example:

Accession: General service enlisted men's uniform buttons, 1855-1884 pattern, 7/8" size, donated by John Smith.

1 lot catalog record: Buttons (object name Button)

Accession: Square cut nails, 1775-1815, 2"-2.5", from Bishop Barnes House attic

1 lot catalog record: Nails (object name Nail)

4. *What are the discipline-specific rules for lot cataloging archives and manuscript collections?*

Don't lot catalog archives and manuscript collections. You catalog archives and manuscript collections as a collection, and measure the size of the collection in linear feet. Refer to Appendix D in this handbook for information on cataloging archives and manuscript collections.

C. Discipline-specific Rules for Lot Cataloging Natural History Collections

1. *What are the rules for lot cataloging natural history collections?*

The reason for lot cataloging natural history specimens depends on the research objectives of the collecting project. In general, to lot catalog natural history collections, the lot must be:

- from the same accession
- from the same locale (same collection effort)
- from the same collection date
- from the same collector(s)
- be studied together as a unit
- be stored as a unit

Example:

Accession: 50 mixed insects and arachnids from a 5-minute sweep net sample

1 lot catalog record: sweep net sample in a single vial of alcohol
Object/Specimen Name: Sweep Net Sample
Quantification: Item Count = 150 and Storage Unit = EA

Accession: thousands of insect from a single light trap that was run overnight

1 lot catalog record: light trap sample in a single vial or jar
Object/Specimen Name: Light Trap Sample
Quantification: Item Count = 0, Quantity = 1, and Storage Unit = Vial or Jar

Accession: 10 dental and skeletal fragments from a paleontological specimen
Object/Specimen Name: Coryphodon radians (genus and species)
Quantification: Item Count = 10 and Storage Unit = EA

See Appendix H in this handbook for additional information on cataloging units. Appendix H is in a separate notebook.

2. *How does lot cataloging relate to the research objectives of the collecting project?*

Some studies require collecting and studying samples that include many individual specimens. The collector collected the specimens as a unit and intends to study them as an assemblage. The definition of collection unit will, to some extent, be an arbitrary decision of the collector. The same is true for such collection data as date and time. For example, a light trap sample may represent hours of sampling time.

Locale is another variable. The collector determines if specimens collected within centimeters or meters of each other are from the same locale.

3. *Does lot cataloging vary from taxon to taxon?*

Yes. Mammal, birds, and reptiles are generally collected as individuals and are rarely lot cataloged. Smaller reptiles and amphibians are occasionally lot cataloged if they are collected on the same date from small sampling plots. Fish, particularly smaller, more common species, are frequently cataloged as a lot. Numerous specimens may be collected from a single seine haul or during electro-fishing or rotenone sampling.

Invertebrates are lot cataloged more than vertebrates. There are well-developed sampling techniques for invertebrates. For example, there are malaise traps, light traps, and pitfall traps for terrestrial arthropods. There are various grab, core, sled, or dredge samples for benthic and epibenthic organisms. There are a variety of net samplers for planktonic organisms.

Most plant specimens, like vertebrates, are collected as single individuals. Generally, give each herbarium sheet one catalog number. Count it as one item, even if the sheet has more than one plant of the same species. On occasion, numerous individuals of the same species are collected on the same date from a single sampling area. In these cases, you may lot catalog the specimens using more than one herbarium sheet. For example, if the

specimens from the sample are on four herbarium sheets, give them all the same catalog number. Enter 4 in the Item Count field on the catalog record.

Assign one catalog number and lot catalog paleontological specimens that make up one individual. You can also lot catalog a matrix that has a mix of fossils from several individuals of the same species.

4. *What is the maximum allowable taxonomic diversity within a lot?*

Taxonomic diversity is the dissimilarity among specimens. In general, you can determine lots by the lowest taxonomic level to which the specimens are identified when you accession them. This will vary from group to group depending on the:

- difficulty of identification within the group
- level of expertise of the collector, donor, or curator

Usually vertebrates, vascular plants, and large fungi will be identified to species. Insects or mollusks may be lot cataloged at the filing group level (line 4 of the classification). They may be undescribed as a species, and often only a few specialists can recognize them to family and genus. Other invertebrates or microscopic organisms, such as nematodes or protozoans, may be grouped at the major group level (line 3 of the classification).

If specimens are lot cataloged at the classification level, list the classification level entry in the Object/Specimen Name field. Enter Unknown in the classification levels that are lower than the last known entry.

5. *Are the procedures for lot cataloging natural history specimens different from cataloging specimens individually?*

No. The specific steps and guidelines for lot cataloging are essentially the same as those you use to catalog specimens individually. Treat the entire lot (rather than the individual components of the lot) as a single specimen. Enter the number of specimens (or number of parts of one specimen) in the Item Count field in ANCS+.

Use the Description field in ANCS+ to describe, in general terms the:

- contents of the lot
- specifics about the collection procedure, date, time of day
- associated data about climate and environment

Example:

Approximately 50 *Daphnia pulex* in various stages of development from a ten-meter plankton tow using a 100 micron mesh plankton net.

Place a completed NPS natural history label in the storage container for the lot. The label includes the catalog number and other pertinent information and identifies the lot. In some cases components of the lot have their own labels, such as pinned insects. You don't have to affix catalog numbers to individual items in a lot if they don't normally have individual labels.

6. *What do I do if I need to remove specimens from the lot?*

Scientists frequently borrow specimens for identification purposes. You need to track specimens that you remove from a lot temporarily for study. Record the following information:

- a full description and count of the specimens
- the name of the person who will be responsible for them
- where they will be kept
- the date they were removed
- the date they are to be returned

<i>If the specimens...</i>	<i>Then track them...</i>
will be gone for less than 30 days,	with a Receipt for Property, Form DI-105.
will be gone for more than 30 days,	with an Outgoing Loan Agreement, Form 10-127

Refer to Chapter 5 in this handbook for information about loans.

Place an Object Temporary Removal Slip, Form 10-97, or a note with the remainder of the lot. Refer to Section II in Chapter 4 of this handbook for information about Form 10-97. Record the same information on the note as in the list above. Use black ink on acid-free paper.

7. *What if specimens in a lot are recataloged?*

In the course of future study, it is likely that researchers will identify or re-identify specimens within a lot. Assign individual catalog numbers to single specimens or smaller lots of specimens. For example, a specialist may use environmental monitoring samples to document changes in species diversity over a period of twenty years. During that time, the specialist may identify all or some of the specimens in the original lot. As this happens:

- store the identified specimens with other fully identified specimens of the same or related taxon
- cross-reference to the catalog record for the original lot
- adjust the Item Count field for the original lot to show the removal of specimens
- include a cross-reference on the original record to the catalog records for specimens that have been removed from the lot

Note: If a specialist identifies many specimens of a single species from a lot, you can create another lot catalog record at the species level.

D. List of Figures

Figure I.1
Figure I.2
Figure I.3
Figure I.4
Figure I.5

Completed Catalog Record – Lot Cataloging (Archeology)
Completed Catalog Record – Lot Cataloging (Archeology)
Completed Catalog Record – Lot Cataloging (History)
Completed Catalog Record – Lot Cataloging (Biology)
Completed Catalog Record – Lot Cataloging (Geology)

MUSEUM CATALOG RECORD-CR		REGISTRATION DATA	
CLASSIFICATION ARCHEOLOGY	OBJECT LOCATION UNC LABORATORY OF ARCHEOLOGY	CONTROLLED PROPERTY N	
PREHISTORIC	OBJECT STATUS AND YEAR LOAN OUT - NON-NPS 1998	PARK ACRONYM PARK	CATALOG NUMBER 28020
MINERAL	ACQUISITION TYPE FIELD COLLECTION	ACQUISITION DATE 09/05/1998	ACCESSION NUMBER PARK-00248
CERAMIC	OBJECT	ITEM COUNT 26	LOT QUANTIFICATION STORAGE UNIT EA
VESSEL FRAGMENT	DESCRIPTION SAVANNAH FINE CORDMARKED. APLASTIC, GRIT. APLASTIC, SAND. BODY.		
	COILED. FIRED. CORD IMPRESSED. T AND E. MATERIALS. FOOD. PROCESSING.		
	SITE OF ORIGINAL COLLECTION/PROVENIENCE 248.2 09CH0002 TR0450-0530N0666E CONNINGHAM_BECKETT_NC	SITE OF ORIGIN CONNINGHAM_BECKETT_NC_USA	
	CULTURAL IDENTITY	OBJECT DATE 1200 --AD -- -- 1325 --AD	HISTORIC / CULTURAL PERIOD MISSISSIPPIAN
	DIMENSIONS/WEIGHT _ 466.40 G _ _ _	PHOTO NUMBER	OTHER NUMBERS PARK-00248
	MEDIUM/MATERIALS CLAY	EMINENT FIGURE ASSOCIATION	CONDITION COM/GD
	IDENTIFIED BY AND DATE OGLETHORPE, MARK 09/09/1998	ARTIST/MAKER	MAINTENANCE CYCLE 5.0/1998
	CATALOGER AND DATE ASWORTH, MARY 10/09/1998	VALUE AT ACQUISITION, BASIS	CURRENT VALUE, DATE, BASIS
	RESTRICTION N REPRODUCTION N PUBLICATION CITATION N PRESERVATION TREATMENT N	CATALOG FOLDER	SIGNIFICANCE N
U.S. DEPARTMENT OF THE INTERIOR MUSEUM CATALOG RECORD - CULTURAL RESOURCES NATIONAL PARK SERVICE FORM 10-254 REV. 7/84			

Figure I.1. Completed Catalog Record – Lot Cataloging (Archeology)

MUSEUM CATALOG RECORD-CR CATALOG DATA REGISTRATION DATA		MUSEUM CATALOG RECORD - CULTURAL RESOURCES NATIONAL PARK SERVICE FORM 10-254 REV. 7/84	
CLASSIFICATION ARCHEOLOGY PREHISTORIC ANIMAL BONE OBJECT BONE	OBJECT LOCATION UNC LABORATORY OF ARCHEOLOGY OBJECT STATUS AND YEAR LOAN OUT - NON-NPS 1998 ACQUISITION TYPE FIELD COLLECTION	PARK ACRONYM PARK ACQUISITION DATE 09/05/1998 LOT QUANTIFICATION ITEM COUNT STORAGE UNIT 1.00 BAG	CONTROLLED PROPERTY N CATALOG NUMBER 25185 ACCESSION NUMBER PARK-00248
DESCRIPTION ANIMALIA BYPRODUCT, RESIDUALS, FOOD PROCESSING, FAUNA			
SITE OF ORIGINAL COLLECTION/PROVENIENCE 248.1 09CH 0002SQ0420N0670E; LV03 CONNINGHAM _ BECKETT _ NC	SITE OF ORIGIN CONNINGHAM _ BECKETT _ NC _ USA		
CULTURAL IDENTITY	OBJECT DATE	HISTORIC / CULTURAL PERIOD	
DIMENSIONS/WEIGHT 84.5 G ---	PHOTO NUMBER	OTHER NUMBERS PARK-00248	
MEDIUM/MATERIALS BONE	EMINENT FIGURE ASSOCIATION		
IDENTIFIED BY AND DATE OGLETHORPE, MARK 09/05/1998	CURRENT VALUE, DATE, BASIS		
CATALOGER AND DATE ASWORTH, MARY 09/15/1998	VALUE AT ACQUISITION, BASIS		
RESTRICTION N REPRODUCTION N PUBLICATION CITATION N PRESERVATION TREATMENT N	CATALOG FOLDER N	SIGNIFICANCE N	SIGNIFICANCE N

Figure I.2. Completed Catalog Record – Lot Cataloging (Archeology)

MUSEUM CATALOG RECORD-CR		REGISTRATION DATA	
CLASSIFICATION HISTORY	OBJECT LOCATION BLDG 45 RM 14 CAB 5 DR C	CONTROLLED PROPERTY N	
COMMUNICATION ARTIFACTS DOCUMENTARY ARTIFACT	OBJECT STATUS AND YEAR STORAGE 1998	CATALOG NUMBER PARK 17719	NUMBER
	ACQUISITION TYPE GIFT	ACQUISITION DATE 04/08/1998	ACCESSION NUMBER PARK-00001
OBJECT PLATE, COMMEMORATIVE		LOT QUANTIFICATION ITEM COUNT 11	STORAGE UNIT EA
DESCRIPTION: RED ON WHITE. BORDER PATTERN SAME ON ALL. DESIGNS OF SHIPS AND MARITIME SCENES. U.S. NAVAL ACADEMY COAT OF ARMS AT TOP. CENTER PATTERN DIFFERS ON EACH PLATE. SHOWS SCENE AT U.S. NAVAL ACADEMY. STAMPED IN RED ON BACK OF EACH: "WEDGEWOOD/ETRURIA/ENGLAND." EACH ALSO HAS IMPORTER STAMP. ETCHED ON BACK: "WEDGEWOOD/3A44." FOUND IN PARK 17718 (BOX).			
SITE OF ORIGINAL COLLECTION/PROVENIENCE BULL RUN _ORANGE_NJ__USA	SITE OF ORIGIN _STAFFORDSHIRE__ENGLAND		
CULTURAL IDENTITY	OBJECT DATE	HISTORIC / CULTURAL PERIOD	
DIMENSIONS/WEIGHT H 2.4, DIAM 26.3 CM _ _ _ _	PHOTO NUMBER	OTHER NUMBERS	
MEDIUM/MATERIALS STONEWARE		CONDITION COM/EX	MAINTENANCE CYCLE
IDENTIFIED BY AND DATE RAMIREZ, JOSE 06/01/1998	Eminent Figure Association WEDGEWOOD/MANUFACTURER		
CATALOGER AND DATE RAMIREZ, JOSE 06/01/1998	VALUE AT ACQUISITION, BASIS	CURRENT VALUE, DATE, BASIS \$25 06/01/1998 CATALOGER	
RESTRICTION N REPRODUCTION N PUBLICATION CITATION N PRESERVATION TREATMENT N	CATALOG FOLDER	SIGNIFICANCE	N
U.S. DEPARTMENT OF THE INTERIOR MUSEUM CATALOG RECORD - CULTURAL RESOURCES NATIONAL PARK SERVICE FORM 10-254 REV. 7/84			

Figure I.3. Completed Catalog Record – Lot Cataloging (History)

REGISTRATION DATA		CATALOG DATA	
CLASSIFICATION	OBJECT LOCATION	CONTROLLED PROPERTY	
BIOLOGY	L140 MS CAB 14 DR B	N	
ANIMALIA	OBJECT STATUS AND YEAR	PARK ACRONYM	CATALOG NUMBER
INSECTA	STORAGE 1999	PARK	NUMBER
LEPIDOPTERA	ACQUISITION TYPE	ACQUISITION DATE	ACCESSION NUMBER
	FIELD COLLECTION	06/06/1999	PARK-00074
OBJECT/SPECIMEN NAME	LOT QUANTIFICATION		
Gnophaela _____ vermiculata _____ GROTE _____	ITEM COUNT	STORAGE UNIT	EA
	10		
DESCRIPTION	ADULTS; CATALOGUED AS SERIES (ALL WERE STORED IN SAME ENVELOPE WITH SAME DATA).		
	FAMILY ARCTIIDAE (TIGER MOTHS)		
	DRIED, STORED FOLDED IN CELLOPHANE ENVELOPE. PINNED AND SPREAD BY MARIAH KOLWALSKI, JULY 1999.		
COLLECTION SITE	PARK	TOWNSHIP/RANGE/SECTION	COUNTY STATE
MERSER RIVER VALLEY	PARK		MONROE OR
WATERBODY/DRAINAGE	UTM Z/E/N	LAT.	LONG.
	10/608181/5198717		ELEVATION DEPTH
HABITAT/DEPOSITIONAL ENVIRONMENT	FORMATION-PERIOD DIMENSIONS/WEIGHT		
	COLLECTION NO.	COLLECTION DATE	MAINTENANCE CYCLE
	FS 120	07/29/1998	5.0/1999
COLLECTOR	MACDONALD, JAMES	CONDITION	COM/GD
IDENTIFIED BY AND DATE	MITSUHIRO, YOSHIMURA 07/10/1999	TYPE	VALUE AT ACQUISITION, BASIS
		N	CURRENT VALUE, DATE, BASIS
CATALOGER AND DATE	COLTON, WILLIAM T. 07/13/1999	EMINENT FIGURE ASSOCIATION	
		OTHER NUMBERS	
RESTRICTION	REPRODUCTION	PUBLICATION CITATION	PRESERVATION TREATMENT
N	N	N	N
			CATALOG FOLDER
			SIGNIFICANCE
			N
U.S. DEPARTMENT OF THE INTERIOR			
MUSEUM CATALOG RECORD - NATURAL HISTORY			
NATIONAL PARK SERVICE			
FORM 10-254B			
REV. 7/84			

Figure I.4. Completed Catalog Record – Lot Cataloging (Biology)

MUSEUM CATALOG RECORD-NH		REGISTRATION DATA	
CLASSIFICATION GEOLOGY ROCKS IGNEOUS VOLCANIC AND SHALLOW-INTRUSIVES	OBJECT LOCATION USGS MENLO PARK CA	CONTROLLED PROPERTY N	
OBJECT/SPECIMEN NAME BAKER LAKE VOLCANIC ROCK CORE SAMPLES __ANDESITE, DACITE AND PUMICE	OBJECT STATUS AND YEAR LOAN OUT - 1999	PARK ACRONYM PARK	CATALOG NUMBER 9765
	ACQUISITION TYPE FIELD COLLECTION	ACQUISITION DATE 01/21/1999	ACCESSION NUMBER PARK-01114
		LOT QUANTIFICATION ITEM COUNT 12	STORAGE UNIT EA
DESCRIPTION PALEOMAGNETIC CORE SAMPLE: ANDESITE OF MAULEY COVE 79 PLUS MINUS 13,74 PLUS OR MINUS 10KA, SKELL HEAD ANDESITE.			
CATALOG DATA		MUSEUM CATALOG RECORD - NATURAL HISTORY	
COLLECTION SITE MAULEY COVE	PARK PARK	TOWNSHIP/RANGE/SECTION SKAGIT	COUNTY WA
STATE WA			
WATERBODY/DRAINAGE	UTM Z/E/N	LAT. __48__95__237__95	ELEVATION DEPTH
HABITAT/DEPOSITIONAL ENVIRONMENT VOLCANO	FORMATION/PERIOD MOUNT MAZAMA, CASCADES	DIMENSIONS/WEIGHT	
COLLECTOR HERTZOG, DONNA	COLLECTION NO. 4B438	COLLECTION DATE 08/16/1997 --AD --	MAINTENANCE CYCLE 0.9/1999
IDENTIFIED BY AND DATE HERTZOG, DONNA 08/21/1997	TYPE N	VALUE AT ACQUISITION, BASIS EMINENT FIGURE ASSOCIATION	CONDITION COM/EX
CATALOGER AND DATE LOPEZ, JUAN 01/23/1999	RESTRICTION N	REPRODUCTION N	PUBLICATION CITATION N
	PRESERVATION TREATMENT N	CATALOG FOLDER N	SIGNIFICANCE N
U.S. DEPARTMENT OF THE INTERIOR		NATIONAL PARK SERVICE	
		FORM 10-254B REV. 7/84	

Figure I.5. Completed Catalog Record – Log Cataloging (Geology)

Appendix J: Marking

	<u>Page</u>
A. Marking Guidelines	J:1
Why do I mark museum objects with a catalog number?.....	J:1
When should I mark the number on the object?	J:1
What are the general rules for marking objects?	J:1
Can I tag objects in addition to marking them with a catalog number?	J:1
How do I mark objects that are on loan to my park?	J:2
Are there marking techniques that I can't use?	J:2
What if I have objects in my collection that have been marked or tagged with incorrect materials?	J:3
What should I do about previous catalog numbers from former owners?.....	J:3
Can I use bar codes to mark objects?	J:3
Should I remove numbers from objects that I deaccession?.....	J:3
B. Applying and Removing Numbers	J:3
What is the most common technique for marking numbers on objects?	J:3
What tools and materials do I need for marking objects with lacquer and ink?	J:4
How do I apply the number?	J:4
When do I remove a catalog number from an object?	J:5
How do I remove a catalog number from an object?.....	J:5
C. Marking Human Remains	J:5
Are there special procedures for marking human remains?	J:5
How do I mark human remains?	J:5
D. Marking Paper Items	J:6
How do I mark paper items?.....	J:6
What tools and supplies do I need for marking paper items?	J:6
Where do I mark paper items?	J:6
How do I remove an incorrect catalog number from paper items?.....	J:7
E. Plastics, Vinyl, Resins, and Rubber	J:7
How do I mark plastics, vinyl, resins, and rubber?	J:7
Why can't I use standard labeling practices with these materials?	J:7
What tools and supplies can I use to mark plastic, vinyl, resin, and rubber objects?.....	J:7
What are some methods for marking plastics, vinyl, resins, and rubber?	J:7
Where do I place the catalog number for different plastic, vinyl, resin, and rubber objects?	J:8
How do I attach the catalog number to different plastics, vinyl, resins, and rubber?.....	J:8
F. Marking Textiles	J:8
What tools and supplies do I use to mark textiles?	J:8
How do I mark textiles?	J:9
Where do I place the catalog number on textiles?	J:9
How do I attach the catalog number to textiles?.....	J:9
How do I remove an incorrect catalog number from textiles?	J:10
G. Large and Small Objects and Unstable Surfaces	J:10
Are there special techniques for marking large objects?.....	J:10
What are the tools and supplies I'll need to mark large objects?	J:10
How do I paint numbers on large objects?	J:10
Where do I place the catalog number for large objects?.....	J:10
How do I remove an incorrect catalog number?.....	J:11

Are there special techniques for marking small objects?	J:11
How do I mark objects that have unstable surfaces?	J:11
H. Leather and Baskets	J:11
How do I mark soft leather and hide?	J:11
How do I mark baskets, mats, bark cloth, and other fibrous materials?.....	J:11
I. Numbering Component Parts, Pairs, and Sets	J:11
How do I number objects with component parts?.....	J:11
How do I number pairs?.....	J:12
How do I number sets and kits?	J:12
J. Number Location for Specific Types of Objects	J:12
K. Natural History Specimens	J:15
What are natural history specimen labels?.....	J:15
Who completes the natural history specimen label?	J:15
What if the labels on my specimens are incomplete?	J:15
When do I create new NPS labels?	J:15
Where can I get natural history labels?	J:15
What kind of supplies do I need to mark and label natural history specimens?.....	J:15
How do I mark a number on a natural history specimen?	J:15
How do I mark plant specimens?	J:16
How do I mark vertebrate specimens?	J:16
How do I mark invertebrate specimens?	J:17
How do I mark paleontology specimens?.....	J:17
How do I mark geology specimens?.....	J:18
How do I mark microscopic specimens?	J:18
When do I use an annotation label?	J:18

APPENDIX J: MARKING

A. Marking Guidelines

1. *Why do I mark museum objects with a catalog number?*

The catalog number on the object links the object with the catalog record, the accession records, and other documentation. The catalog number identifies the object. You need it for accountability and access. Mark all objects in the park's permanent museum collection with a catalog number that includes the:

- park acronym
- collection designator (if applicable)
- unique number

Example: INDE 3487

2. *When should I mark the number on the object?*

Mark objects as part of the cataloging process. Mark the object at the same time that you complete the catalog record. Don't mark numbers on objects until you are ready to catalog them. It's a lot easier to change a catalog number in ANCS+ than to remove a number from an object. You also run the risk of assigning duplicate catalog numbers if you mark numbers on the objects before you catalog them.

3. *What are the general rules for marking objects?*

There are different techniques for marking different types of materials, but every catalog number should be:

- legible and easily found (don't place the catalog number on the underside of a heavy object)
- durable but not damaging
- in a location that doesn't detract from the scientific, historic, aesthetic or intrinsic value of the object (doesn't cover any diagnostic or potentially informative features)
- unobtrusive (not directly visible when the object is on display)
- in a location where it won't receive excessive wear
- secure enough that it cannot be removed accidentally
- reversible

It's much easier to find catalog numbers if you place them in the same position on similar objects. For example, number framed images on the reverse lower right corner.

4. *Can I tag objects in addition to marking them with a catalog number?*

Yes. In addition to the permanent catalog number, you may want to tag objects in storage. Tags make it easier to identify and find objects and reduce handling. Use an acid-free, cotton tag with cotton string, and place it in a visible location. Don't use metal-rimmed tags. Don't attach tags with tape or glue. Don't place the tag on weak parts of the object.

5. *How do I mark objects that*

Never mark a number on objects that are on loan to the park. Attach an acid-free tag to the object using cotton string.

are on loan to my park?

If a tag is too obtrusive for a loan that is on exhibit, keep a detailed list of the catalog numbers for the loaned objects in the exhibit. Note the location of each loaned object in the exhibit and take photos to identify each object.

You don't have to catalog objects on loan to your park for less than a year. Use the lender's catalog number, if available, for tracking purposes.

Note: NPS centers and non-NPS repositories receive incoming loans from parks for the purposes of curation and storage. The center or repository marks the park catalog number on the objects as part of the cataloging process.

6. *Are there marking techniques that I can't use?*

Yes. Don't use any technique that permanently alters the object, such as etching, scribing, imprinting, stamping, engraving, or scratching. These methods are irreversible and permanently alter the object.

You can stamp, etch, or otherwise mark "Reproduction" on objects that are reproductions. For contemporary reproductions, you can add the craftperson's name and the date. Refer to Section IV in Chapter 4 of this handbook and the *MH-III*, Chapter 5: Three-Dimensional Reproductions, for information on reproductions.

Don't use the following materials:

- epoxy and cement
- nail-on tags
- nail polish and nail polish remover
- pressure sensitive tapes and labels (cellophane, masking, plastic, and adhesive)
- rubber cement
- spray varnishes
- typewriter correction fluid
- tags attached with wire
- staples or paper clips
- paint or ink on paper documents

7. *What if I have objects in my collection that have been marked or tagged with incorrect materials?* Consult with a conservator about removing old numbers and tags. Some old numbers and tags may be historically important and shouldn't be removed. Place any tags you remove in the catalog or accession folder. If a tag will be destroyed during removal, copy the information, and place it in the catalog or accession folder.
8. *What should I do about previous catalog numbers from former owners?* Previous catalog numbers are part of the documentation for the object. Don't remove these numbers unless:
- confusion with park numbers is likely
 - the number is causing damage to the object
 - the number occupies space needed for the park number

Never remove field specimen numbers.

Note: If you must remove a previous owner's numbers, consult a conservator. You will have to test for the correct solvent before removing the number.

Place tags you remove in the catalog or accession folder.

If a tag will be destroyed during removal, copy the information and place it in the catalog or accession folder.

9. *Can I use bar codes to mark objects?* No. Some NPS centers are using bar codes successfully to help track the movement of objects. Bar codes require the use of a software package to produce them, a printer to print them, and a scanner to read them. At present, bar codes are not a substitute for marking the catalog number on an object. The bar code tags can become separated from the objects. There are still no satisfactory methods of adhering the tags to most objects.
10. *Should I remove numbers from objects that I deaccession?* No. Let the recipient decide whether to remove the numbers.

B. Applying and Removing Numbers

1. *What is the most common technique for marking numbers on objects?* You will usually use lacquer and ink when numbering museum objects. Use this method for all objects except:
- incoming loans
 - paper
 - textiles
 - objects with unstable surfaces
 - plastics, vinyl, resins, and rubber
 - some natural history specimens

Refer to Sections C-J in this appendix for information on marking specific

materials.

2. *What tools and materials do I need for marking objects with lacquer and ink?*

You'll need these tools and materials to mark objects with lacquer and ink:

- clear lacquer (Acryloid B-72® acrylic resin/acetone)
- white lacquer (Acryloid B-72® acrylic resin/acetone with titanium dioxide white pigment)
- permanent waterproof ink (Higgins® Black Magic® or Pelikan 17)
- technical pen (Rapidograph®), or crowquill pen
- acetone and cotton swabs for cleaning surfaces and removal of lacquer to correct errors, if needed
- artist brushes

3. *How do I apply the number?*

To apply the number:

- Make sure the area is clean and free of dust.
- Apply a small rectangle of clear or white lacquer on the object using a small artist's brush or cap brush. Use clear lacquer on light objects and white lacquer on dark objects. Usually a spot 1/8" wide by 3/8" long is sufficient.
- Allow the lacquer to dry thoroughly.
- Write the catalog number on the spot, using permanent black ink and a crowquill or Rapidograph® pen. Keep a small jar of ammonia and water handy for cleaning pen tips.
- Allow the ink to dry. Drying times will vary depending on the material and climate.
- Cover the number with a coat of clear lacquer to protect it. The clear lacquer topcoat should extend just beyond the lacquer primer rectangle.

*Refer to **Conserve 0 Gram 1/4, Use of Acryloid B-72 Lacquer for Labeling Museum Objects**, for detailed instructions on applying catalog numbers.*

Apply numbers in a well-ventilated area, and use latex or cotton gloves when marking metal objects.

Note: You can get Material Data Sheets on Acryloid B-72 and acetone from the Supply and Equipment Program of the Museum Management Program.

4. *When do I remove a catalog number from an object?*

Remove a catalog number only when necessary. You will need to remove numbers when the:

- number is incorrect
- ink smears
- object is removed from a lot and individually cataloged

When in doubt, consult your regional/support office (SO) curator or a conservator before removing numbers.

Refer to Section A.8 for information about catalog numbers from previous owners.

5. *How do I remove a catalog number from an object?*

Before you remove a catalog number, you need to know what marking materials were used on the object. Check with a conservator if you're not sure. Be aware that removing numbers can alter the object. For example, you may lose a small amount of the finish on finished wooden objects.

Before 1987 the NPS used shellac for marking objects. Remove shellac with denatured alcohol.

In early 1987, the NPS issued a cellulose nitrate lacquer (clear and white) from GSA. In April 1987, the NPS switched to the acrylic lacquer (clear and white) currently in use. You can remove all these lacquers with acetone, but check to make sure there is no shellac overcoat. Sometimes lacquer was used with a shellac overcoat.

To remove the number:

- Make sure you work in a well-ventilated area.
- Apply a small amount of solvent with a cotton swab. The material is carried into the swab rather than diluted and absorbed into the object.

C. Marking Human Remains

1. *Are there special procedures for marking human remains?*

Yes. Consult with affiliated groups about marking human remains. It may be inappropriate to place catalog numbers on these items. An alternative is to mark or tag the container.

2. *How do I mark human remains?*

To mark cremations:

- Completely enclose the burial vessel with unbleached muslin and fasten it with cotton twill tape.
- Attach the catalog number and any other labels to the twill tape. Use acid-free paper or Tyvek® for the labels.

To mark inhumations:

- Group small bones by type and place them in a polyethylene bag.

Place an acid-free label in each bag.

- Place the catalog numbers on the storage container.

To mark skeletal remains with soft tissue:

- Place the catalog number on an acid-free tag, and tie the tag to the remains or the storage container.

D. Marking Paper Items

1. *How do I mark paper items?*

Never use ink or indelible pencils to mark paper items. Use #2H, HB or softer pencils only. You want to use a pencil that won't indent but yet is hard enough not to smear. Write lightly, so you don't leave an impression. Place the object on a clean hard surface before numbering it. You can use a sheet of heavy Mylar.

2. *What tools and supplies do I need for marking paper items?*

Use the following tools and supplies when marking paper items:

#2H, HB, or softer pencils
acid-free paper photographic enclosures
Mylar sleeves
archival film pen

3. *Where do I mark paper items?*

There are various locations for marking paper items.

Individually cataloged paper items

Place the catalog number directly and inconspicuously on the reverse side in the lower right corner. If the item has embrittled edges, place the number away from the edge. If the object is in special housing, number the housing as well as the object.

Archival and manuscript collections

Place the catalog number on the folder.

Books

Place the number inside the front cover at the lower edge of the right hand corner, and on the back of the title page at the lower edge of the right hand corner.

Framed objects

Place the catalog number on the frame and object, on the reverse, lower right edge.

Photographs

Place the catalog number on the reverse, lower right edge. If the number wears off you will have to reapply it. If necessary, set up a monitoring cycle to check the catalog numbers for wear.

For photographs in acid-free paper or Mylar enclosures, mark the enclosure. Use an archival film pen on Mylar sleeves. Mark the sleeve before placing the photograph inside.

When working with photographs, remember that inks (ballpoint pen, felt-tip, manuscript, and rubber stamp) may be acidic and can cause fading of silver images.

Never list additional information on the backs of photographs. Use a cross-reference sheet to list information about names of individuals in group shots.

Photographic negatives

Don't mark the negatives directly. Place the number on the acid-free

(including glass plates)

enclosures that hold the negatives. Mark the number on an archival print of the negative to make sure that you don't lose the number.

4. *How do I remove an incorrect catalog number from paper items?*

If you need to remove an incorrect number, use a white vinyl eraser. Avoid abrading the paper by keeping the pressure as light as possible.

E. Plastics, Vinyl, Resins, and Rubber

1. *How do I mark plastics, vinyl, resins, and rubber?*

There's no single method for applying catalog numbers to these materials. Identification of different types of plastics, vinyl, resins, and rubber is difficult. Their chemical compositions vary and can interact negatively with standard labeling materials.

2. *Why can't I use standard labeling practices with these materials?*

Solvents such as acetone and toluene may:

- dissolve the surfaces of some plastics
- cause stress cracking or crazing
- destroy some glossy finishes

Some water-based materials initiate stress cracking over time. In addition, these materials are not reversible in water when dry.

Regular oil paints and their solvents soften or otherwise damage some plastics over time.

Inks often contain metallic elements that can degrade rubber.

3. *What tools and supplies can I use to mark plastic, vinyl, resin, and rubber objects?*

Use the following tools and supplies when marking plastics, vinyl, resins, and rubber:

Teflon® tape (plumbers tape) with archival film pen
Mylar with archival film pen and nylon or Teflon® monofilament
cotton twill tape and pigma pen
acid-free paper tags with pigma pen

4. *What are some methods for marking plastics, vinyl, resins, and rubber?*

If possible, apply the catalog number to a component of the object not made of these materials using standard techniques with lacquer and ink or pencil. If you can't do this, consider doing one of the following:

- Use Teflon® tape (plumbers tape) and an archival film pen.
- Use Mylar, and an archival film pen. (This may be the most unobtrusive way to label objects on exhibit.)
- Label the container or object mount.

- Use an acid-free paper tag and pigma pen.
- Use cotton twill tape and a pigma pen.

Write the catalog number on the labeling material before attaching it to the object. See E.6 for information on how to attach the labeling material to the object.

If you need to apply a number directly to an object consult with a conservator.

5. *Where do I place the catalog number for different plastic, vinyl, resin, and rubber objects?*

Placement of the catalog number for objects made of these materials will vary. It depends on the type of object, whether the object is on exhibit, and the labeling technique you use. Place numbers in a consistent location for the same types of objects. Keep in mind standard concerns. The number should be legible, durable, reversible, non-damaging, non-obtrusive, and easily found.

6. *How do I attach the catalog number to different plastics, vinyl, resins, and rubber?*

Make sure you apply the catalog number to the labeling material and allow it to dry before attaching the number to the object. Attach the number in a secure and unobtrusive but easily found location.

<i>If you use...</i>	<i>Then...</i>
Teflon® tape or twill tape,	use the tape itself to secure the catalog number to the object.
Mylar,	round the edges of the tag so they can't damage the object, and use chemically inert Teflon® monofilament to secure the tag to the object.
acid-free paper tags,	use cotton string to secure the catalog number to the object.
the mount or container,	use either lacquer and ink or pencil directly on the mount or container. For objects in storage you may place a tag inside the container.

F. Marking Textiles

1. *What tools and supplies do I use to mark textiles?*

Use the following tools and supplies when marking textiles:

cotton twill tape
pigma pen
colorfast cotton thread (Mettler, Guttermann, and cotton quilters thread)
small, sharp needles, various sizes
small, sharp sewing scissors
tweezers

2. *How do I mark textiles?*

Use permanent black ink (pigma pen), cotton twill tape, and colorfast cotton thread to mark textiles. Choose a size and weight of twill appropriate for the object. Use white thread, except for objects on exhibit. Write the catalog number on the cotton twill tape. After the ink has dried thoroughly, baste the tape to the textile.

Baste the linen tape directly onto the textile with colorfast cotton thread. For fragile or open weave items, such as lace, attach the tape with a small loop of thread.

3. *Where do I place the catalog number on textiles?*

Garments

Place the catalog number in the neckband or waistband of the garment. For garments on exhibit, place the number in an unobtrusive location. For example, place the number on the right or left side of the neckband rather than the center. This location will be less visible when the object is on display. If the threads go through the back of the garment where they could be visible, use colorfast cotton thread matching the fabric of the garment.

Flat textiles

For flat textiles, such as rugs, linens, draperies, and flags, place the number on the underside of the garment. Use colored colorfast thread that matches the color of the fabric for items on exhibit.

Rolled textiles

For rolled textiles, place the number so that it is readable without having to unroll the item.

4. *How do I attach the catalog number to textiles?*

Use a basting stitch to attach the twill tape to the textile. Baste all four sides of the twill tape using large stitches. If you only baste the ends of the tape, something could catch between the object and the tape. With a one inch strip of twill tape, you would use one stitch on each end and two on each side.

Keep a loose tension on the thread. Too much tension can stress the textile. Too little tension will leave loose threads that can catch on things and cause damage.

There are two methods for starting and ending your stitches. One method is to use the same holes and go through your first and last stitch twice. This leaves a tail at each end so someone can tell where you started and ended your stitches.

To use the second method, leave a tail with your thread when you start to stitch. After you are done, bring the tail through the second stitch and bring the ending tail back through the third stitch. You'll need tweezers for this technique.

Note: Don't use a knot to start and end your basting. You can pull knots through the fabric causing damage.

For loose weave textiles like lace, loop the string that holds the twill tape label through the weave.

5. *How do I remove an incorrect catalog number from textiles?*

Choose the finest needle that will work for the task. For silk, use numbers 10, 11, 12, or a quilting needle. Rugs may need a number 6 needle. Carefully lift the end of the thread, and pull it gently through the label.

G. Large and Small Objects and Unstable Surfaces

1. *Are there special techniques for marking large objects?*

Yes. Large objects such as wagons, cannons, anchors, and objects kept outdoors need especially durable numbers. Paint the number on the object following the instructions in Section F.3 below. Locate the number in the same place in a protected but accessible area for each type of object.

In addition to the painted number, you may choose to add a supplemental tag. Make sure the tag is attached with something non-abrasive.

You may attach a supplementary stamped or engraved aluminum tag to large outdoor items. Attach these tags with Teflon® tape. This tape is soft, chemically inert, and water, oil, chemical, and insect resistant.

For objects in storage, you can print information on 8 ½ x 11" paper or card stock that you put in a polypropylene bag. Attach the bag to the object with polyester or polypropylene cord in a prominent place.

For objects on exhibit, you may also use a Mylar tag. Round the corners so the sharp corners can't cause damage. This material is resistant to oil, water, and insects. Attach the tag with Teflon® monofilament, or for equipment you can use Teflon® tape.

2. *What are the tools and supplies I'll need to mark large objects?*

Use the following tools and supplies to mark large objects:

aluminum tags
Dymo® labeler (for use with aluminum tags)
engraving or stamping tools (use only on aluminum tags)
pencil or knitting needle
string ties or Teflon® monofilament
Teflon® tape to secure tags
red cadmium or black carbon pigment oil paint
mineral spirits
Tyvek® for labels
Mylar tags

3. *How do I paint numbers on large objects?*

Use mineral spirits to clean and degrease the area where you will apply the catalog number. When it dries, apply the number directly on the object. Use an appropriate size sable brush and cadmium red or black carbon pigment oil paint.

You may need to trim the brush and thin the paint with turpentine. Choose the color of paint based on the color of the object.

4. *Where do I place the catalog number for large objects?*

Apply the number to the right rear of vehicles or boats. Use an out-of-the-way but consistent spot. Because large objects are hard to move, be sure to place the number in an area that is easy to access.

5. *How do I remove an incorrect catalog number?*

While still wet you may remove the paint with VMP Naptha or turpentine.

Once dry, removing the paint will require a strong solvent like methylene chloride. A conservator or qualified member of the staff should perform this task. It's easier to paint over the number with artist's oil paint and reapply the correct number.

6. *Are there special techniques for marking small objects?*

If an object is too small for marking, place the object in a small container, and mark the container. Containers include vials, polyethylene bags, or acid-free envelopes. Place an additional tag inside the container. Tag containers of lot cataloged objects in the same way.

7. *How do I mark objects that have unstable surfaces?*

Some objects may have an uneven, friable, or powdery surface, such as corroded metals or leather objects. Don't use lacquer and ink on these objects. Place the catalog number on an acid-free paper or Tyvek® tag, and attach it with cotton string or polypropylene cord.

H. Leather and Baskets

1. *How do I mark soft leather and hide?*

Don't use lacquer and ink to mark soft leather or hides. You may use lacquer and ink on hard finished leather. Use either an acid-free tag or a textile label to mark soft leather and hide. Use existing holes in the piece to loop the tag through the label, or secure the label to an appendage. When using existing holes, take care not to stress the material.

In some cases, you can mark a component of the object. For example, mark one of the metal pieces of a bridle rather than the leather.

2. *How do I mark baskets, mats, bark cloth, and other fibrous materials?*

On some baskets and fibrous materials it may be difficult to use lacquer and ink because of the narrowness or texture of the fibers. You can apply lacquer and ink to these items, if the surface is firm. When in doubt, use acid-free tags or cotton twill tape. For flat items, place the number on the reverse right corner.

I. Numbering Component Parts, Pairs, and Sets

1. *How do I number objects with component parts?*

Number objects with component parts with the catalog number and the component part designator. Mark each component individually. Each part has a unique lower case suffix.

Example:

<u>Object</u>	<u>Components</u>	<u>Catalog Number on Object</u>
Teapot	Teapot	PARK 5a
	Lid	PARK 5b

See Section I of Appendix C in this handbook for a discussion of component parts. If you need more than 26 letters, double the letters. For example, use 10aa, 10ab, 10ac, and so forth.

Note: Don't use component part designators with biological specimens, such as animal skeletons. Count the bones, and enter this number in the

Item Count field in ANCS+. Mark each bone with the same catalog number. Place bones too small to be individually numbered in a vial with a specimen label showing the catalog number.

2. *How do I number pairs?*

Number pairs, such as a pair of shoes, with the catalog number and a component part designator. Mark each item individually.

Example:

<u>Object</u>	<u>Components</u>	<u>Catalog Number on Object</u>
Spur	Spur	PARK 4511a
	Spur	PARK 4511b

See Section I of Appendix C in this handbook for a discussion of pairs.

3. *How do I number sets and kits?*

Number sets and kits as you would number an object with component parts. Number each piece of the set individually with the catalog number and a component part designator. Each piece has a unique lower case suffix.

Example:

<u>Object</u>	<u>Components</u>	<u>Catalog Number on Object</u>
Kit, Needlework	Thread	PARK 78a
	Thimble	PARK 79b
	Needles	PARK 80c

See Section I of Appendix C in this handbook for a discussion of sets and kits. If you need more than 26 letters, double the letters. For example, use 10aa, 10ab, 10ac, and so forth.

J. Number Location for Specific Types of Objects

As a rule, place the catalog number in the same location on all objects of the same type. The list in this section includes standard locations and techniques for marking various types of objects.

<u>Object</u>	<u>Location</u>	<u>Marking Material</u>
Armor	Inside each element.	lacquer and ink
Baskets	On base. Don't place catalog numbers on a portion of the basket that may conceal diagnostic information. Tag baskets that are fragile.	lacquer and ink or tag
Beads	Place on the edge or on an attached tag. Put the object in a clear vial container or polyethylene bag with a paper label inside.	tag or place in a marked container

<u>Object</u>	<u>Location</u>	<u>Marking Material</u>
Books	On endpaper (blank leaf inside front cover), lower edge near spine, and on lower edge, right hand corner on back of the title page. Loose pages must receive the same catalog number, individually on reverse, lower right.	soft pencil (#2H, HB or softer)
Buttons	On reverse side or same procedure as beads.	tag or place in a marked container
Ceramic, glass, pewter	On the underside, but avoid parts that would be abraded when the object is moved. Label whole ceramic vessels on the exterior base, near the center. Number sherds on the undecorated surface. Use multiple applications of lacquer on porous surfaces to build up a base that will prevent absorption of ink.	lacquer and ink
Clothing	Place the number on cotton twill tape, and sew it on the costume to the neckband or waistband. Sew the number on in a location that is easily seen during inventory but not so obvious during exhibition.	sew-on label
Coins	On the edge/rim. <i>Don't</i> number mint condition coins. Place the number on the container holding the coin.	lacquer and ink
Documents, photos, prints, letters, postcards, and envelopes	Reverse, lower right corner.	soft pencil (#2H, HB or softer)
Dolls wooden or china head	Back of neck or bottom of foot.	lacquer and ink
Firearms	Inside trigger-guard, or on the breech of the barrel opposite the lock, or on the lower right butt.	lacquer and ink
Flags/pennants/banners	Reverse side at top of hoisting edge.	sew-on label
Framed image	Reverse, lower right corner of frame.	lacquer and ink
Furniture	Near the inside top of the right rear leg; or for pieces without legs, on the right side near rear corner. Number heavy objects on the right side/leg at the base. Place number so it can be seen easily during inventory, but not obvious when on exhibit.	
beds	Top of back, right headpost or foot rail.	lacquer and ink
trunk/chest	Top right corner of back.	lacquer and ink
chairs, sofas	Top right of back leg, or seat frame.	lacquer and ink

<u>Object</u>	<u>Location</u>	<u>Marking Material</u>
mirrors	Lower right corner of back of frame.	lacquer and ink
stoves	Top right corner of back.	lacquer and ink
tables	Apron or top right corner of a leg at one end of table.	lacquer and ink
Jewelry	Smooth surface on the right lower corner on reverse side. Number cotton twill tape and sew around necklaces, bracelets, and rings.	lacquer and ink or cotton twill tape
Model vehicles, boats	Right side of back end or stern.	lacquer and ink
Paintings	Reverse, lower right corner. Number both stretcher and frame, in case they are separated. <i>Don't</i> place numbers or labels on the front or back of the canvas. For heavy frames that are difficult to remove from the wall, use the lower right corner on the side of the frame. Number scroll paintings on the scroll knob.	lacquer and ink
Rugs, tapestries, and drapes	Reverse side, lower right corner.	sew-on label
Scabbard	On reverse of the throat, at top, or (absent a throat) on the body near an opening.	lacquer and ink
Scrapbooks, albums	Lower corner near spine inside front cover.	soft pencil (#2H, HB or softer)
Sculpture in the round	At the rear of the base near the bottom; also at the lower edge of the back of pedestal.	lacquer and ink
Sculpture in relief	Lower right of back or edge in an inconspicuous place.	lacquer and ink
Stamps	Write the number on the back of the stamp with a soft pencil. You can also place stamps in acid-free containers, and label the container.	soft pencil (#2H, HB or softer) or place in a marked container
Stone	On base center. Don't put a number on flaking areas.	lacquer and ink
Swords, daggers, and knives	On reverse of the blade, on ricasso just below the counter guard, if it will not likely be scraped off by the scabbard.	lacquer and ink
Tools	Working part of tool (on head rather than on handle.)	lacquer and ink

For further information on placement of numbers see *The New Museum Registration Methods*, Washington, DC: American Association of Museums, 1998.

K. Natural History Specimens

1. *What are natural history specimen labels?*

The NPS uses standardized natural history specimen labels to identify all natural history museum collections. These labels are mandatory for all natural history specimens. See Appendix H in this handbook for a description and illustrations of the labels and their uses. Appendix H is in a separate notebook.

2. *Who completes the natural history specimen label?*

The collector or specialist usually completes the label. The accession and catalog numbers are added to the label after the specimen is cataloged. This may be done by park staff, the collector, or the repository that manages the specimens. Refer to Section VI in Chapter 4 of this handbook for information on following regulations for cataloging natural history specimens.

3. *What if the labels on my specimens are incomplete?*

Complete them using data provided by the collector. Follow the instructions in Appendix H of this handbook.

4. *When do I create new NPS labels?*

Only remove old labels if they are damaging the specimen. If you must remove the old label, place it in the accession or catalog folder. Never discard old labels!

Don't remove clearly legible, well-attached collector labels that have much of the information required on NPS specimen labels. Add any additional or new information, such as accession and catalog numbers, to the NPS label, and keep both labels with the specimen.

5. *Where can I get natural history labels?*

ANCS+ can produce all the required natural history labels. The program also completes most of the information on the label from data you enter on the catalog record. Use acid-free paper to produce labels.

6. *What kind of supplies do I need to mark and label natural history specimens?*

Use the following supplies to mark and label natural history specimens:

acid-free NPS natural history labels
glue for labels (white glue such as Elmers glue)
permanent, waterproof black ink
clear lacquer for rocks and minerals (Acryloid B-72® acrylic resin/acetone)
white lacquer for rocks and minerals (Acryloid B-72® acrylic resin/acetone with titanium dioxide white pigment)
acetone
polyvinyl acetate adhesive 5% in ethanol
crowquill or Rapidograph® pen.

7. *How do I mark a number on a natural history specimen?*

You don't mark the catalog number directly on all natural history specimens. For some specimens, mark the number only on the label.

When applying the catalog number to a specimen, use ink and lacquer. Follow the procedures in Section B of this appendix. Make sure you don't cover important features with the number. Place the catalog number and label in a location that minimizes handling the specimen.

Place very small specimens in vials, and attach a label to the vial. If appropriate, place the catalog number inside the vial. Place insect labels on

an insect pin.

When attaching labels directly to a specimen, use cotton thread. For oily and wet specimens you may want to use a polypropylene cord.

For lot cataloged specimens, place a label on the storage container. Place an additional tag inside the container. Refer to Appendix I in this handbook for information on cataloging specimens in lots.

8. *How do I mark plant specimens?*

Herbarium specimens

Don't mark the number directly on the specimen. Glue the Herbarium Collection Label, Form 10-512, on the lower right corner of the herbarium sheet. Mark the catalog and accession numbers on the label.

Don't use starchy pastes. They can attract insects and mold. Don't use glues with a toluene or acetone base (model airplane glues). White glue, such as Elmers glue or polyvinyl acetate emulsion works well.

Nuts, large seeds, and wood specimens

Place the number on the specimen. Use clear lacquer for a primer coat with permanent black ink and a protective overcoat of clear lacquer.

Wet plant specimens

Don't mark the number directly on the specimen. Write the accession and catalog numbers on a Wet Plant Specimen Label, Form 10-506, and place it in the jar or container. Currently you should get labels for wet specimens from the Supply and Equipment Program of the Museum Management Program.

9. *How do I mark vertebrate specimens?*

Bones

Place the number directly on vertebrate bones. Use clear lacquer for a primer coat with permanent black ink and a protective overcoat of clear lacquer. Locate catalog numbers:

- in the center of the largest part of the bone
- near the proximal end of long bones
- at the lower back center of the skull
- on the right ramus of the jaw

Put small bones in a vial or box and write the accession and catalog numbers on the Skull Vial or Box Label, Form 10-502. Place the label in or on the container.

Wet vertebrate specimens

Don't place numbers directly on wet vertebrate specimens. Write the accession and catalog numbers on the Vertebrate Wet Specimen Label, Form 10-500. Place this label in the jar or container. You can also write the numbers on a Vertebrate Specimen Label, Form 10-501. Tie it to:

- the right hind leg above the ankle
- for fish, through a nose or gill
- for some amphibians and reptiles, around the body near the head.

Currently you should get labels for wet specimens from the Supply and Equipment Program of the Museum Management Program.

Animal skins

Place the number on flat skins. Use clear lacquer for a primer coat with permanent black ink and a protective overcoat of clear lacquer. Locate the number on the reverse, on the inside of the neck, or on the right hind leg. You can also number flat skins by writing the catalog number on a Vertebrate Specimen Label, Form 10-501. Attach the label to a right hind leg. For large skins, attach it through a natural opening like an eye or the nose.

Eggs

Place the number directly on the eggs. Use clear lacquer for a primer coat with permanent black ink and a protective overcoat of clear lacquer. Also write the catalog number on an Egg Box Label, Form 10-508. Attach the label to the outside of the box with polyvinyl acetate adhesive 5% in ethanol (PVA).

10. *How do I mark invertebrate specimens?*

Insects

Don't place numbers directly on the insect. Write the accession and catalog numbers on an Insect Label, Form 10-509. Pin the insect with a rust-proof insect pin. Then pin the label at standard height, below the specimen, parallel to the insect's longitudinal axis. The label must be readable from the left side. A collector's label indicating locality, collector's name, and date may exist on a separate label placed in a similar orientation below the insect label.

Other Invertebrates

Place the number directly on other invertebrates, such as shells. Use clear lacquer for a primer coat with permanent black ink and a protective overcoat of clear lacquer. Locate the number on the interior, bottom, or reverse of the specimen. Write the accession and catalog numbers on the Invertebrate Label, Form 10-507, or the Invertebrate Specimen Label, Form 10-503. Place the label in the container with the specimen.

Wet invertebrate specimens

Write the accession and catalog numbers on the Invertebrate Label, Form 10-507, or the Invertebrate Specimen Label, Form 10-503. Place the label in the jar or container with the specimen.

Currently you should get labels for wet specimens from the Supply and Equipment Program of the Museum Management Program.

11. *How do I mark paleontology specimens?*

Place the number on the specimen. Use clear or white lacquer for a primer coat with permanent black ink and a protective overcoat of clear lacquer. Locate the catalog number in a flat inconspicuous surface, where it will not wear off or obscure any important features. Write the accession and catalog numbers on the Paleontology Label, Form 10-505. Place the label with the specimen.

Fossil resins may dissolve in solvents. Don't apply lacquer to a specimen of this type without consulting a conservator. Write the catalog number on an acid-free tag, and attach or place it with the specimen. You can also write the number on Teflon® tape with archival film pens, and tie the tape to the specimen.

12. *How do I mark geology*

You can usually mark the number directly on the specimen using lacquer

specimens?

and ink. Don't use lacquer with extremely fibrous and powdery or flaky specimens. Write the catalog number on an acid-free paper tag or cotton twill tape, and attach or place it with the specimen. Make sure the pressure of securing it won't damage the specimen.

If the specimen is a resin it may dissolve in solvents. Don't apply lacquer to a specimen of this type without consulting a conservator. Write the catalog number on an acid-free tag, and attach or place it with the specimen. Alternatively, write the number on Teflon® tape with archival film pens, and tie the tape to the specimen.

Rocks

Use clear or white lacquer for a primer coat with permanent black ink and a protective overcoat of clear lacquer. Locate the catalog number in a flat inconspicuous surface, where it will not wear off or obscure any important features. Keep the number small. Also print the accession and catalog numbers on the Geology Label, Form 10-504. Place the label with the specimen.

Minerals

Use clear or white lacquer for a primer coat with permanent black ink and a protective overcoat of clear lacquer. Locate the catalog number in a flat inconspicuous surface, where it will not wear off or obscure any important features. Keep the number small. Print the accession and catalog numbers on the Mineral Label, Form 10-511. Place the label with the specimen.

13. *How do I mark microscopic specimens?*

For glass slides use clear lacquer for a primer coat with permanent black ink and a protective overcoat of clear lacquer. For cardboard slides, use pencil to write the number. Write the number on the end of the slide. Avoid touching the cover slip.

Write the accession and catalog numbers and any additional information, if provided, on a small acid-free paper label. For geology specimens, additional information might include age and formation. Store the labels by catalog number, near the specimen microscopic slides. These labels are not standardized.

14. *When do I use an annotation label?*

Use an Annotation Label, Form 10-510, when a specialist reviews a specimen to verify or correct the scientific name. Attach the annotation label to the specimen, or store it with the specimen. Include the name confirmation or change of name, the name of the identifier, and the date of review on the label.

Appendix K: Photography

	<u>Page</u>
A. Museum Record Photography	K:1
Why should I photograph museum collections?	K:1
When should I photograph museum collections?	K:1
Do I need to hire a photographer if I have no photography experience?	K:1
How can I learn how to photograph objects?	K:1
Do I need to follow the procedures in this appendix?	K:1
Do I need to photograph the entire collection?	K:1
When should I photograph archival materials?	K:1
Can I use digital imaging for record photography?	K:2
Should I use color or black and white film for record photography?	K:2
How many photos do I need for each object?	K:2
What's the most important point to remember about museum record photography?	K:2
B. Equipment	K:2
What equipment will I need for record photography?	K:2
What additional equipment might be useful for photographing objects?	K:5
C. Procedures	K:5
What are the basic procedures for taking photographs of museum objects?	K:5
What are the step-by-step procedures for taking record photographs?	K:6
D. Processing the Film	K:13
Can I process the film at the park?	K:13
What do I need to know about using a commercial lab?	K:13
What if I can't find a lab that processes black and white film?	K:13
What kind of photos should I get?	K:13
E. Documentation and Storage	K:14
Why is it important to document photographic negatives and prints?	K:14
What is the photograph number?	K:14
How do I document the prints?	K:14
How do I store the prints?	K:14
How do I store contact sheets?	K:15
How do I document and store the negatives?	K:15
Where do I store the object photograph log?	K:15
What's the best storage environment for photographs and negatives?	K:15
F. List of Figures	K:16

APPENDIX K: PHOTOGRAPHY

A. Museum Record Photography

- Why should I photograph museum collections?*

Photography is an excellent supplement to cataloging. In most cases, photos are more effective than words in describing objects. Narrative description of texture, marks, damage and materials is difficult. Most of these qualities are apparent in a good photograph. Photographs are especially useful for recording the condition of an object. In the case of a loss or theft, a good photograph can help in recovering the object.

Photographs also reduce the need for handling objects. In many cases, you can use a photo for initial research rather than handling the objects.
- When should I photograph museum collections?*

You should photograph objects:

 - as part of the cataloging process
 - to document accessions and the condition of incoming loans
 - to document the condition of outgoing loans
 - before deaccessioning them
- Do I need to hire a photographer if I have no photography experience?*

No. You should be able to take acceptable record photos using the procedures in this appendix. If you have a large collection to photograph or want photos for publications, you may want to hire a professional photographer.
- How can I learn how to photograph objects?*

Become familiar with the equipment, especially how the camera operates. Read the camera operating manual, and practice. You will gain expertise through trial and error and experience.
- Do I need to follow the procedures in this appendix?*

No. This appendix gives you a list of the necessary equipment and a simple process for photographing museum objects. If you are an experienced photographer you can use your own methods and setup.
- Do I need to photograph the entire collection?*

No. You should photograph all controlled property. You must decide if a photograph is useful for non-controlled property. You can photocopy, rather than photograph, some archival materials. Refer to Sections C.9 and C.10 in Chapter 3 of this handbook for information about collections to photograph.
- When should I photograph archival materials?*

Photograph, rather than photocopy, archival materials if the item:

 - is of very high artifactual value and is a continuous tone photograph (silver gelatin photoprint, platinum print, or similar process)
 - is a detailed visual image with many nuances, such as an original drawing or architectural plan
 - has nuances that can't be captured by a photocopy machine, such as a beautifully handwritten letter
 - is of high evidential value, such as a land document

Note: Archival collections usually have very few items that you will need to photograph for documentation purposes. Consider the importance of the collection when deciding what to photograph.

You may want to photograph many archival items for access and use such as posting on the Web. These aren't photographs for documentation.

8. *Can I use digital imaging for record photography?*

No. Digital images are wonderful for access but, at present, not good for long-term preservation. Digital data can fail and vanish overnight. It is much more fragile than film, and has a shorter life expectancy. It also requires frequent migration to be compatible with rapidly changing hardware and software. There is a high cost to managing, refreshing, and migrating digital files over time.

You may want to purchase a digital camera to take images at the same time you are doing record photography. ANCS+ allows you to attach digital images to your catalog records. See Section VIII in Chapter 6 of the *ANCS+ User Manual* for information on using images with ANCS+.

Note: Video can also be useful for documenting collection storage, exhibit installations, and other collection activities.

9. *Should I use color or black and white film for record photography?*

Use black and white film for record photography. Black and white acetate film should last 100 years if stored at temperatures below 70° F and 30 - 50% relative humidity levels. Color film doesn't last nearly as long, but you may want to use it for additional images of your objects.

10. *How many photos do I need for each object?*

The number of photos you need for each object depends on the object. Complex objects may require several shots at different angles. If you are documenting condition, marks, or inscriptions, you may need close-up shots of particular areas. On the other hand, many objects may need only one photo taken at different exposures.

11. *What's the most important point to remember about museum record photography?*

Be sure to cross-reference the photographs to the catalog records so that you can easily retrieve the photos. Also make sure to record the documentation associated with the photography, such as recording roll and frame numbers. Use of the photo identification stand ensures documentation of the object in the photo. Refer to Section E in this appendix for information on documenting and storing the photographs.

B. Equipment

1. *What equipment will I need for record photography?*

The following list includes the equipment you'll need for record photography:

Camera

Use a 35mm single lens reflex camera. It offers flexibility and quality at a reasonable price. Be sure that you can set the aperture and shutter speed manually on the camera. Automatic cameras must have an override that allows for manual adjustment.

Lens

A 50mm lens has the most useful focal length. A 55mm macro lens is a good choice for small objects and close-up work as well as general use. For wide angle shots, use a 35mm or 28mm lens or a 28-85 or 35-105 lens with a macro feature.

You can use a close-up lens kit to increase focusing capability for small details.

Filter

Use a polarizing filter to reduce reflections and glare. Use an ultraviolet

(UV) filter to protect the front surface of each lens. For black and white images, it may cause a negligible increase in image contrast. For color films it may make the image slightly more reddish if there are light sources other than photoflood lights. You also might want to use polarizing gelatin filters on your lights to reduce reflections and glare.

Lights

Use EBW Number B2 photoflood lamps (500 watts each) mounted in reflectors. The reflectors should be between 10 and 16 inches in diameter with a preferred size of 12 or 14 inches. Quality and cost vary greatly. Some reflectors attach to adjustable lights stands, and others have clamps that you may attach to stable objects such as chairs. Lights are available through most photography supply stores.

Film, Black and White

The following film is recommended for record photography:

- Kodak T-Max 100 and 400
- Ilford Delta 100 and 400
- Kodak Plus-X 125
- Kodak Tri-X

You can get film at bulk rates through the General Services Administration.

Note: There is a new monochrome chromogenic film on the market that is advertised as black and white film. Kodak Advantix is one of the brand names. You can get this film processed at a color lab. The image is a black dye image, rather than silver grains, and is processed the same as standard color negatives. Because the image is dye based, the monochrome chromogenic negatives won't be as stable as traditional black and white films with silver-based images. This film is not recommended for museum record photography.

Film, Color

The following film is recommended for color photography.

- Fuji 160 NPS (daylight) and 160 NPL (tungsten) for color prints (very good dye stability)
- Kodachrome 25 or 64 for color transparencies

Note: Kodachrome is the most stable color transparency film, but it's sometimes difficult to find laboratories to process it.

Developer

For in-house processing, use the developer that the manufacturer recommends. For commercial processing, use the same lab so that processing will be consistent.

Refer to Section D of this appendix for information on processing film.

<i>Tripod</i>	You must have a sturdy tripod to hold the camera steady when using slow shutter speeds. A tripod with 2 or 3 telescoping section legs and a swivel or pan head is best.
<i>Shutter Release Cable</i>	Use a shutter release cable for slow shutter speeds to avoid moving the camera when releasing the shutter cable. The cable attaches to the shutter button. Movement of the camera will result in blurry images. Spending a little more on a cable release by a known manufacturer will ensure longer use.
<i>Exposure Meter</i>	You may use a reflected-light meter, either built into the camera or handheld, for metering the objects. This meter measures the amount of light reflected off the object. You should use it with a gray card. Another type of meter is a handheld incident-light meter, which measures the amount of light falling on an object. You don't need a gray card with an incident-light meter.
<i>Gray Card</i>	Use a gray card to take accurate exposure meter readings under lights with a reflected-light meter. The light reflected from the gray card gives a better reading than the light reflected from the object. An 8 X 10 inch, 18% gray card is available in photography supply stores. See Figure K.1 for instructions on using the Kodak gray card.
<i>Background Paper</i>	Use light gray and dark gray. You can buy this inexpensive paper at any professional photography supply store. It comes in widths of 54 inches to 11 feet by lengths up to 100 feet. There should be a distinct contrast between the object and the background. You can lose detail if the object is the same color or has the same contrast in shades as the background. For example, a piece of wrought iron would not show up well against a black background or a bone against a white background. In certain instances, black may create the best contrast. A large piece (3 X 6 feet) of black velveteen or dense black matte board is useful to have on hand.
<i>Identification Stand</i>	<i>Place a stand with the film roll number and the object's catalog number (including park acronym) in every photograph.</i> This information identifies the object and the photograph. You will need stands for both large and small objects, a roll label, and changeable magnetic numbers and letters. Stands, roll labels, and park acronym letters are available from the Supply and Equipment Program of the Museum Management Program (MMP). Refer to the <i>Tools of the Trade</i> catalog.
<i>Meter Scale</i>	<i>Place a standard metric scale next to or on the identification stand in every photograph.</i> The scale should have alternating black and white blocks in standard metric units. You will need a large and small centimeter scale for objects of different sizes. Scales are available from the Supply and Equipment Program, MMP. Refer to the <i>Tools of the Trade</i> catalog.
<i>Color Control Card</i>	<i>Place a color control card next to the identification card in every color photograph.</i> It provides a control for determining correct color in color printing and for identifying colors in the object. Color control cards are available from photography supply stores.

Gray Scale Control Card

Include a gray scale control card in black and white photographs to provide control for determining correct shades in black and white printing. It's especially good for two-dimensional printed materials. Gray scale control cards are available from photography supply stores.

2. What additional equipment might be useful for photographing objects?

The following list includes some equipment that you might find useful when photographing objects.

Materials to Support Objects

Materials for supporting objects include: styrofoam, plexiglass, cardboard, wood blocks, display easels, and wall hooks.

Diffusion Materials

You can place materials such as Rolux diffusion directly in front of the lights to diffuse them and create more muted shadows. For example, you can create a cone with this material and place it around an object such as a coin. The lights penetrate the material and create smooth, less specular highlights.

It's important to buy diffusion materials designed for use with photo lights. Buy diffusions materials from photography supply stores.

Light Form Panels

Use light form panels to add fill light to an image. They will soften shadows and bring out details that would otherwise be lost in the image. You can place a piece of white poster board in front of an object at an angle to reflect light into shadowed areas. Light form panels are available from photography supply stores.

Copy Stand

Use a standard photography copy stand to take photographs of small or two-dimensional objects. The stand has two or four lights with a temperature of 3200° Kelvin.

C. Procedures

1. What are the basic procedures for taking photographs of museum objects?

The following basic procedures for taking photographs should result in good record photographs. These procedures aren't the only way to photograph museum objects. Photographers with more knowledge and experience may use different techniques and equipment. The procedures in this section provide a simple process that anyone can use.

- group objects by size and type
- prepare background
- place object, identification card, metric scale, gray scale control card (color control card for color) on background paper
- load camera with film, and set the camera to the film speed (ASA, ISO, or EI)
- arrange lights
- mount camera on tripod
- attach shutter release cable
- compose the picture

- turn on lights
- place gray card in front of object and determine exposure
- remove gray card
- take photograph
- turn off lights, or change objects and repeat steps as appropriate
- record information about the photograph

Note: Turning lights on and off helps protect the objects from heat build-up but significantly reduces the life of the bulb. It's important to set up the photograph as much as possible before turning on the lights. It's more efficient to leave the lights on and move the object from under the lights. However, moving the object may not be possible and requires you to handle the object more. You can use a dimmer switch with halogen lights that have appropriate bulbs. Don't leave the objects under the lights for more than a few minutes.

2. *What are the step-by-step procedures for taking record photographs?*

By following the step-by-step procedures in this section, you should be able to produce good photographs of your museum objects.

Grouping Objects by Size and Type

Grouping the objects to be photographed by size and type will save you time and energy. You won't have to adjust distances or heights of the lights or camera for every object. It will also minimize the need to turn the lights on and off. You can remove one object and replace it with another one without having to change the lighting or camera setup.

Preparing the Background

A table against a wall works well for objects under 3 feet in size. Hang the background material on the wall, using drafting tape or gaffer's tape that won't mark the wall. Let the material drape over the table without forming a crease or seam. Larger objects will usually be easier to handle on the floor. For very large objects, you usually won't need a background material.

Placing the Object

Place the object in the middle third of the flat working surface, if possible. This placement avoids having the front edge of the background in the photograph or the back portion of the background in focus. See Figure K.2.

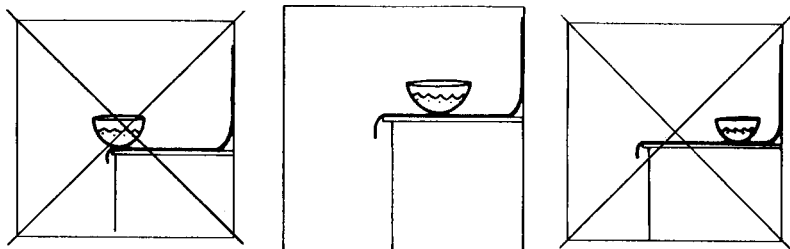

Figure K.2. Placement of Object

Place the identification information near the front of the object without blocking any part of the object. See Figure K.3. The identification information includes:

- identification stand with the catalog number and roll and frame number
- metric scale
- gray scale control card (color control card for color)

Note: Different size objects require different size identification information.

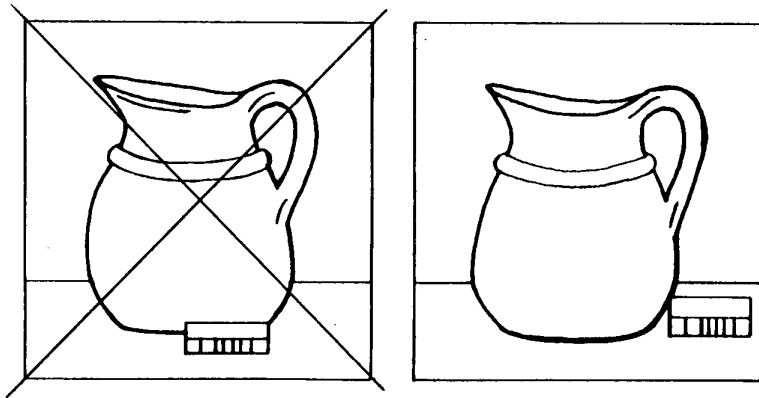

Figure K.3. Placement of Identification Information and Metric Scale

Loading the Film and Setting the Exposure Index

Load the film in the camera. Modern electronic cameras generally don't have rewind buttons. For older camera models or those with rewind knobs, check that the film is advancing properly. Wind to exposure "1" for manual cameras. Then turn the rewind knob carefully in the direction of the rewind arrow until you feel a slight tension. When the film is advanced after the first exposure, the rewind knob should rotate in the opposite direction of the rewind arrow. If the rewind knob doesn't rotate, then the film may not be loaded properly. Reload the film if necessary.

Follow the operating manual for your camera to set the camera to the film speed. Older camera models will use American Standards Association (ASA) to describe film speed. Usually you will see Exposure Index (EI) or International Standards Organization (ISO) on the film box. ASA is equivalent to ISO or EI. Set the Exposure Index on the camera to match the EI of the film.

Number each roll of film consecutively as it is used.

Arranging the Lights

The basic lighting setup for most objects will be a key light and fill light. The key light is the main source of light on the object. The fill light is the secondary light used to minimize shadows. See Figure K.4 and the information that follows below for the distance, angle, and height for the lights.

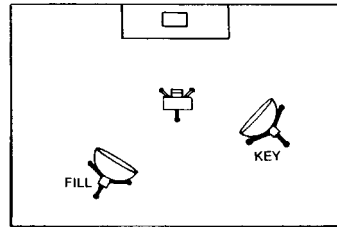

Figure K.4. Basic Lighting Setup

Carefully adjust the distance, angle, and height of the lights. This will make the difference between a properly lit object and one with many obscuring shadows. See Figure K.5 and K.6. Adjust the lights to best illuminate the object. Do this without overhead lights.

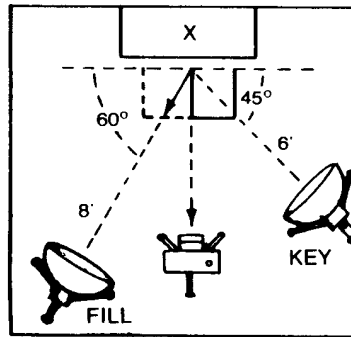

Figure K.5. Distance and Angles for Light Placement

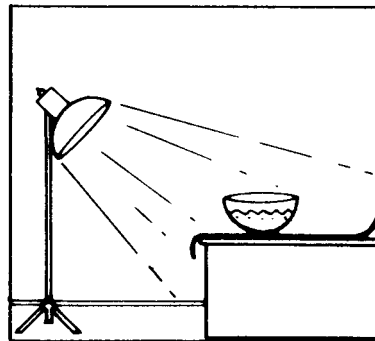

Figure K.6. Height of Light

Use the following standards to set up the lights, and then adjust them as needed for the best results:

- distance key light at 6 feet; fill light at 7 or 8 feet
- angle key light at 45° from the front plane of the object; fill light at 60° to 70° from the front plane of the object
- height high enough to light the top surface and front of the object

You can also use a piece of string and a 12 inch cardboard square to

determine the distance and angles of the lights. To use this procedure:

- draw a diagonal line on the card from point A (starting at a corner) to point D forming a 45° angle
- from point A (the same corner) draw a second line to point C forming a 60° angle
- place the same illustrations on the reverse, keeping the A-D axis on the same diagonal of the card
- cut the string to 8 feet and knot it at 6 and 7 feet
- attach the string at point A
- place the card on the background, with point A on the spot where the object will be and point B in the direction of the camera
- hold the string taut and move around until the string aligns with the A-D line (45° at 6 feet) for the key light
- flip the card and align the string with the A-C line (60° at 7 or 8 feet) to position the fill light

See Figure K.7. CD is half of BD.

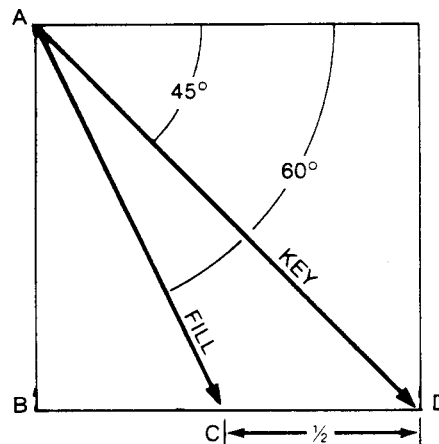

Figure K.7. Angles for Key and Fill Lights

The key light, at 6 feet, will create a harsh shadow. The fill light will lighten the shadow from the key light without creating a second harsh shadow. See Figure K.8.

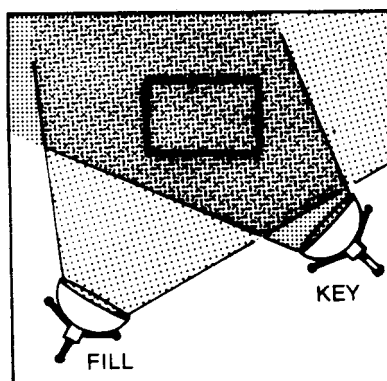

Figure K.8. Relationship of Shadows from Key and Fill Lights

Composing the Photograph

Mount the camera securely on the tripod, and attach the shutter release cable. Check the position of the identification information. Compose the photograph. Make sure the object fills up as much of the photograph as possible. Check the distance, angle, and format (horizontal versus vertical).

Adjust the distance of the camera to the object so that the object fills one-half to three-quarters of the frame. See Figure K.9.

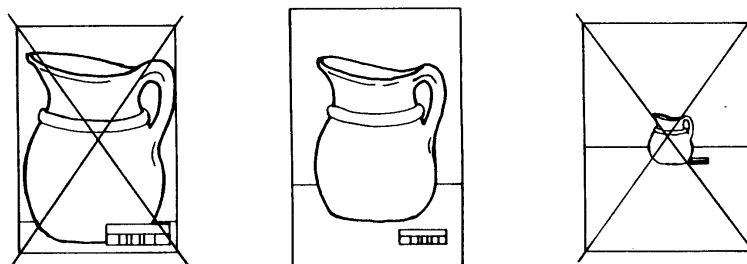

Figure K.9. Composing the Photograph: Distance

Determine the angle. For three-dimensional objects, place the camera slightly higher and looking down on the object. If you shoot the object on a straight line, it won't look three-dimensional. See Figure K.10

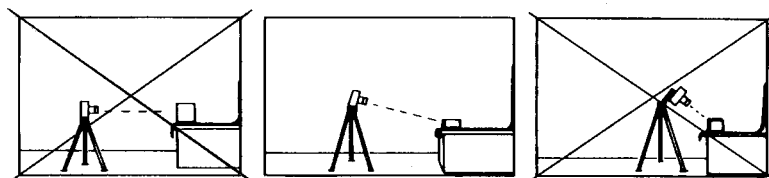

Figure K.10. Composing the Photograph: Camera Angle

For small, two-dimensional objects, use a copy stand that mounts the camera directly above the object. The stand usually includes fixed lights located about 30 inches from the copy board and at a 45° angle to the camera lens axis. Mount large two-dimensional objects on the wall. Place the two flood lights at equal distance and height, at a 45° angle from the object. The camera should be level and aimed at the center point of

the object. Use polarizing filters on the lights and camera lens when

photographing reflective surfaces, such as oil paintings and reflective glass. Use a gray scale control card when photographing black and white photographs.

Choose the format. You want to frame the object within the image so that the object isn't surrounded by extra space.

<i>If the object is...</i>	<i>Then...</i>
taller than it is wide,	use the camera in a vertical position.
wider than it is tall,	use the camera in a horizontal position.

See Figure K.11.

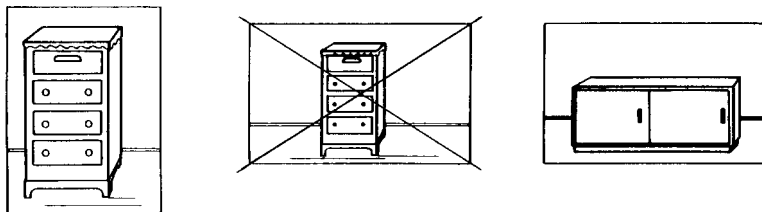

Figure K.11. Choosing Vertical or Horizontal Format

Turning on the Photoflood Lights

Remember that turning lights on and off reduces the life of the bulbs. It's possible to hook both lights up to a foot switch or a hand switch located next to the camera. Using a light switch will:

- minimize the length of time the lights are left on
- protect the objects from heat and humidity changes
- keep the work area cool

Ideally the photoflood lights should be the only source of light. Turn off overhead or other room lights (especially if they are fluorescent lights) because they:

- distort the color in color shots
- dilute the effects of the photoflood lights

Note: Be aware of how light from additional sources such as windows can affect the image, especially an image with a reflective surface. It may be necessary to cover windows or at least shoot the photograph on an overcast day. The room should be dark except for the photo lights.

Placing the Gray Card

Place the gray card perpendicular to the lens line of sight. Take the exposure meter reading using light reflected from the gray card. This reading will be more accurate than one taken using light reflected from the object and background.

Determining Exposure

Start by setting the aperture (f/stop). A larger f/stop number (small aperture) will result in greater depth-of-field (area of sharpness) in the photograph. Once you set the f/stop, match it with the appropriate shutter

speed setting.

To take an exposure reading, use a handheld meter or a camera with a built-in meter. To take a reading with the camera, place the meter near the gray card without casting any shadows on the card. Be certain that the gray card fills the entire viewing screen. The photoflood lights should be on. Take an exposure reading and set the camera f/stop and shutter speed to that reading.

Each package of film has exposure suggestions for different situations.

If a meter isn't available, use the following exposures as a guideline for Kodak T-Max 100 using two 500 watt photoflood lights. As the lights become older, greater exposures will be necessary. When taking photographs in this way, bracket to either side of the first shot. When you bracket, you take additional exposures around your first exposure. For example, for Kodak T-Max 100 ISO at f/16 for 1/8 second, use the following five settings:

- f/22 for 1/8 second
- between f/22 and f/16 for 1/8 second
- f/16 for 1/8 second
- between f/16 and f/11 for 1/8 second
- f/11 for 1/8 second

Exposures for 100 EI Film

Key Light	Fill Light	Exposure
6 ft.	6 ft.	f/16 at 1/8 second
6 ft.	7 ft.	f/16 at 1/8 second
6 ft.	8 ft.	f/16 at ¼ to 1/8 second
7 ft.	8 ft.	f/16 at ¼ second
8 ft.	10 ft.	f/16 at ½ second

Note: You can't use the guidelines for meterless exposure with overhead lights.

Review the negatives and the recorded exposures to judge if the settings are appropriate. Make sure that the negatives are not consistently overexposed or underexposed. Always shoot and process the first roll of film immediately to assess the correct exposure. Then complete the project.

Shooting the Photograph

Remove the gray card. Focus the camera. Squeeze or depress the shutter button slowly and smoothly. The shutter release cable is especially useful because it allows you to depress the shutter button without touching the camera. The shutter release cable eliminates the potential for camera movement, which causes blurry images.

Some objects may require more than one photograph to document detail accurately. After taking all the necessary shots, turn off the lights, and record the information about the photographs. If you're working with similar objects, put the next objects in place, focus, and take the next shots. For different objects, repeat the steps in this section to prepare the next setup.

Recording Information about the Photograph

Each time you use a new roll of film, start a new photograph record log that includes:

- roll number (check the roll number of the previous log sheet)
- exposure number (the frame number on the roll)
- exposure reading (f-stop and shutter speed)
- catalog number
- object name

When the film is processed, the frame number and object may not correspond with the frame number and object listed in the log. Correct the log to correspond with the frame number on the negative. Figures K.12a-b show a blank and sample object photograph record sheet.

D. Processing the Film

1. *Can I process the film at the park?*

Yes. If the park has darkroom facilities, park staff can process the film following the technical data sheet for the developer. Use the appropriate developer for the particular film. For example, process Kodak T-Max 100 using T-Max developer or standard commercial developer. Using a toning solution helps longevity. Most problems with longevity come from insufficient washing.

2. *What do I need to know about using a commercial lab?*

Processing can affect the quality of the final image. It's important to find a good place for processing film and use it consistently. You're then sure that the film is processed the same way each time, and you have a consistently good product.

3. *What if I can't find a lab that processes black and white film?*

Finding a local lab that will process black and white film may be difficult for many parks. You can call Kodak at 1-800-242-2424 to find the professional processing lab nearest to your site. You can also use Kodak's web site at <http://www.kodak.com> to locate a lab near you or in your geographic area.

4. *What kind of photos should I get?*

For record photos, make at least one black and white print for the photo file. Use either 3 X 5 inch prints or contact sheets. Contact sheets can be made exactly the same size as the negative or slightly larger (11 X 14).

E. Documentation and Storage

1. *Why is it important to document photographic negatives and prints?*

You need to document the negatives and prints to access them. Use a numbering system as a cross-reference.

2. *What is the photograph number?*

The photograph number is the roll number followed by the frame number. It serves as the cross-reference between the print, contact sheet, negative, object photograph log, and catalog record.

Roll	Frame	Photo Number
200	3	200/3
2050	25	2050/25

Note: Enter this number in the Images supplemental record in ANCS+. The most recent photo number in the Images supplemental record prints in the Photo Number field on the Museum Catalog Record, Form 10-254 Rev. Refer to Section VII in Chapter 3 of the *ANCS+ User Manual* for information on the Images supplemental record.

3. *How do I document the prints?*

The roll number and object catalog number appear in the photograph. In addition, you'll need to make a label with information about the photograph. Use acid-free paper or the front of an archival paper enclosure for the label. The label should include:

- catalog and accession numbers
- object name
- photo number (roll and frame number)
- date taken
- photographer
- remarks

See Figure K.13 for sample label information.

Note: The National Visual Inventory Card, Form 10-30 is no longer in use.

4. *How do I store the prints?*

File prints numerically by photograph number or catalog number depending on how you want to access the image. Store them in archival quality enclosures, either paper or polyester (Mylar®). There are several styles available. Refer to *Conserve-O-Gram (COG) 14/2*, Storage Enclosures for Photographic Prints and Negatives, and *MH-I*, Appendix R: Care of Photographic Collections. Both paper and polyester enclosures are available from the Supply and Equipment Program, MMP. See the *Tools of the Trade* catalog.

You can write the label information in pencil on the front of paper enclosures. For archival-quality polyester enclosures, place the photo and label back-to-back in double-sided photo sheets or envelopes. This method

allows you to view the photo and label without having to handle the photo. Some parks use a copy of the catalog card and photo back-to-back in a polyester sleeve.

Note: Use plastic materials only if you can maintain relative humidity below 70%.

5. *How do I store contact sheets?*

Place contact sheets or strips in polyester enclosures. Store them in archival quality three-ring binders with the matching photograph log sheets. Binders and enclosures are available from the Supply and Equipment Program, MMP. See the *Tools of the Trade* catalog.

6. *How do I document and store the negatives?*

Cut the negatives into strips. File them by roll and frame number in archival polyester holders. Place them in a three-ring archival quality binder. File one roll on each page. Shooting only 35 frames of a 36 exposure roll makes everything fit on one page.

Mark the roll number, with a permanent marker pen, in the space at the top of the page. You can use contact sheets as indexes to the negatives.

Binders and enclosures are available from the Supply and Equipment Program, MMP. See the *Tools of the Trade* catalog.

7. *Where do I store the object photograph log?*

Store the object photograph log in a three-ring binder and keep it with the museum collection records. File the sheets with the highest number on top. If you use contact sheets, store a copy of the pertinent log sheet with each contact sheet.

8. *What's the best storage environment for photographs and negatives?*

Storage conditions greatly contribute to the stability and longevity of your photographs and negatives. The storage environment is of prime importance. Carefully monitor the temperature and relative humidity (RH) to keep them constant.

Store black and white photographic prints and negatives at 20° C (68°F) or below at a constant RH between 30% and 50% in dark storage. Avoid RH fluctuations of more than 5%. Humidity is the important factor. High RH levels dramatically increase the rate of deterioration. Very dry conditions may cause cracking and embrittlement.

You can significantly increase the film life of black and white negatives by lowering the humidity below 50%.

Store color prints and negatives at 2-10° C (35-50°F) or below at 20-30% RH in dark storage. Temperature is the most significant factor in determining the rate of fading and staining.

You will also want to monitor and control the presence of pollutants in the air. Oxidizing gases and chlorides can greatly contribute to the destruction of photographic material. Dust is especially damaging because of its hygroscopic character. Dust causes abrasion when you move negatives. Never allow smoking in photographic storage areas.

Refer to the *MH-I*, Appendix R: Curatorial Care of Photographic Collections, for additional information on storage environment.

F. List of Figures

K.1	Kodak Gray Card Instructions
K.2*	Placement of Object
K.3*	Placement of Identification Information and Metric Scale
K.4*	Basic Lighting Setup
K.5*	Distance and Angles for Light Placement
K.6*	Height of Light
K.7*	Angles for Key and Fill Lights
K.8*	Relationship of Shadows from Key and Fill Lights
K.9*	Composing the Photograph: Distance
K.10*	Composing the Photograph: Camera Angle
K.11*	Choosing Vertical or Horizontal Format
K.12a	Object Photograph Record Sheet
K.12b	Object Photograph Record Sheet (Sample)
K.13	Labelling for Photo Enclosures (Sample)

* Figures K:2 – K.11 appear in text.

How to Use KODAK Gray Cards...

To Determine Exposure

- All meter readings of the gray card are reflection measurements of *incident* illumination on the card. To get accurate exposure information, be sure the gray card is receiving the same illumination as the subject to be photographed.
- Position the gray card facing the camera so there are no shadows on it, no brightly colored objects reflecting light on it, and no glaring (specular) reflections coming off the card itself.
- Normally you should use the gray side of the card and the rated ISO speed of the film to figure exposure. (Or, if the light is so dim that your meter will not read the gray side, divide the film speed by 5, reset your meter to this value, and read the white side of the card.)
- To be sure you read only the card, hold your meter about 6 inches (15 centimetres) away. Of course, if you are using a single-lens-reflex camera with a built-in meter or spot meter, you can see exactly what you are reading.
- In artificial light, position the card close to and in front of the subject, aimed halfway between the main light and the camera.
- In daylight, position the card facing the camera and as close to the subject as possible. Or, you can make an exposure reading of the card near your camera, as long as you position the card so it receives the same angle and intensity of illumination as the subject.
- If your subject is quite dark, *increase* your calculated exposure by ½ to 1 stop.
- If your subject is quite light, *decrease* your calculated exposure by ½ to 1 stop.
- Bracket your exposures in situations where you are unsure of the best exposure.

To Determine Lighting Ratios

- A lighting ratio expresses the relationship between main plus fill-in illumination and fill-in illumination alone.
- Generally, the lighting ratio should not exceed 3 to 1 for color or 5 to 1 for black-and-white when full detail is wanted in a final print.
- You can use a KODAK Gray Card to determine, and if necessary adjust, the lighting ratio of a particular setup even if the lighting arrangement is complex. To do so, follow these suggestions:
 - Position the card as close to the subject as possible.
 - When reading main plus fill-in illumination, turn the card to the position that gives the maximum reading on the scale of your light meter. For this reading, all lights should be on except those positioned so far to the side or back that they might influence the meter directly. Record the reading.
 - When reading fill-in illumination, turn the card so it faces the camera lens, and turn off the main light or lights. Record the reading.
 - With both readings recorded, you can determine the lighting ratio by using the table at right.

© Eastman Kodak Company, 1983

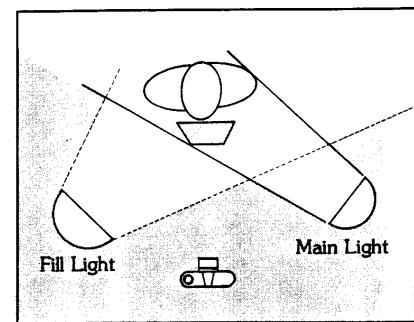
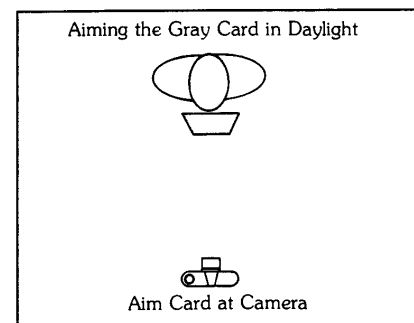
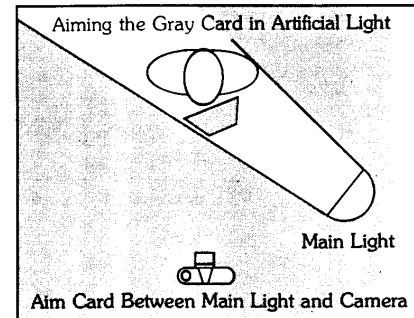

Stops Difference	Lighting Ratio	Stops Difference	Lighting Ratio
2/3	1.5:1	2 2/3	6:1
1	2:1	3	8:1
1 1/3	2.5:1	3 1/3	10:1
1 2/3	3:1	3 2/3	13:1
2	4:1	4	16:1
2 1/3	5:1	5	32:1

Figure K.1. Kodak Gray Card Instructions

OBJECT PHOTOGRAPH RECORD SHEET

PARK
PARK

Photographer: STEVE SMITH

Date: 5 Jul 2000

Roll no. 1021

EXP. NO.	EXP.	CAT. NO.	ITEM	EXP. NO.	EXP.	CAT. NO.	ITEM
1	f/16 1sec	PARK 2902	Basket				
2	f/16 1sec	PARK 2903	Basket				
3	f/16 1sec	PARK 3000	Basket				
4	f/11 1sec	PARK 2904	Rug				
5	f/11 1sec	PARK 2905	Sculpture				
6	f/16 1sec	PARK 3005-3007	Necklace, Ring, Bracelet Set				

Figure K.12b. Object Photograph Record Sheet (Sample)

Catalog Number	(Roll/Frame Number)
Accession Number	
Object Name	
Date Taken	
Photographer Name	
Remarks	

Figure K.13. Labelling for Photo Enclosures (Sample)

Appendix L: Reporting and Documenting Loss of Museum Objects

Page

L.1 Overview

- L.1.1 What is the definition of “loss”? L:1
- L.1.2 Where can I learn about prevention of loss? L:1
- L.1.3 Where can I find the procedures for investigating and documenting a loss? L:1

L.2 Discovering Loss

- L.2.1 Who usually discovers a loss? L:2
- L.2.2 What should I do if I discover a loss due to vandalism, theft, or loss of a firearm? L:2
- L.2.3 What should I do if I discover a missing object during inventory? L:2
- L.2.4 What should I do about objects that may have been missing for many years? L:2

L.3 Reporting Loss

- L.3.1 Who is responsible for reporting the loss of museum objects? L:3
- L.3.2 How does park law enforcement report losses due to vandalism or theft or loss of a firearm?..... L:3
- L.3.3 Should I report stolen museum collections to outside agencies? L:3

L.4 Documenting Loss

- L.4.1 How do I document a loss? L:4
- L.4.2 When should I complete the Report of Survey? L:4
- L.4.3 Where can I find the procedures for DOI-AAAP-0111? L:4
- L.4.4 What if the object is found? L:5

L.5 Determining Accountable Action

- L.5.1 Who determines accountable action for stolen, lost, damaged, or destroyed museum property? L:5
- L.5.2 What if the superintendent is unable to make a determination? L:6
- L.5.3 What documentation does the custodial officer give to the accountable officer? L:6
- L.5.4 What actions are taken for a determination of No Negligence? L:7
- L.5.5 What actions are taken for a determination of Simple Negligence? L:7

L.5.6 What actions are taken by the superintendent for a determination of Gross Negligence?.. L:7

L.6 Determining Gross Negligence

L.6.1 What is a Board of Survey? L:7

L.6.2 What actions are taken by the Board of Survey?..... L:9

L.6.3 What actions are taken by the Reviewing Authority?..... L:9

L.6.4 What actions are taken by the Regional Director?..... L:9

L.6.5 What actions are taken by the Office of Inspector General (OIG)? L:9

L.6.6 May a liable individual(s) appeal a finding of Gross Negligence? L:9

L.6.7 What actions are taken by the Office of Hearings and Appeals? L:10

L.6.8 What actions are taken if a damaged object must be destroyed? L:10

L.7 List of Figures

L.7.1 Outside Agencies that Report or Search for Lost Objects L:11

L.7.2 Report of Survey (DI-103) L:12

L.7.3 Background and Determination of Personal Property Negligence Memo (Sample)..... L:13

Appendix L: Reporting and Documenting Loss of Museum Objects

L.1 Overview

L.1.1 What is the definition of “loss”?

The term “loss” means traumatic and total loss:

- theft
- destruction
- disappearance

Loss does not refer to losses of integrity (breakage, fading, infestation, or other deterioration) or the deliberate deaccession of objects, such as transfers.

L. 1.2 Where can I learn about prevention of loss?

Refer to the *Museum Handbook*, Part I, Chapter 9, Fire Protection; Chapter 10, Emergency Planning; and Chapter 14, Security.

L.1.3 Where can I find the procedures for investigating and documenting a loss?

Refer to these documents for procedures to investigate and document a loss:

- Director’s Order #9: Law Enforcement Program and the Law Enforcement Reference Manual
- Director’s Order #44: Personal Property Management and the Personal Property Management Handbook #44
- DOI-AAAP-0111: Stolen, Lost Damaged, or Destroyed DOI Personal Property and Technical Operating Procedures for Stolen, Lost, Damaged, or Destroyed DOI Personal Property

There may also be park-specific and regional procedures for investigating losses.

L.2 Discovering Loss

L.2.1 Who usually discovers a loss?

Staff conducting the annual inventory most frequently discover losses. You may also receive loss reports from maintenance staff, security personnel, or interpreters. These staff members may notice something missing when they make their customary rounds.

L.2.2 What should I do if I discover a loss due to vandalism or theft or loss of a firearm?

- make a copy of the catalog record
- locate any photographs or digital images of the object
- gather any additional information that might be useful from ICMS or the accession and catalog folder
- notify your Regional Curator
- give all information to a park law enforcement officer within 24 hours after discovery of the loss

Note: Some parks have a designated law enforcement officer who is responsible for the museum collection. If the park does not have a law enforcement officer, notify law enforcement at a neighboring park or regional law enforcement.

L.2.3 What should I do if I discover a missing object during inventory?

Search the area to see if the object has been misplaced in a nearby location. If you can't locate the object:

- note that the object is missing on the inventory form
- conduct research to determine when the object was last seen (former inventories, photo date, catalog record date)
- document your findings

L.2.4 What should I do about objects that may have been missing for many years?

Objects or specimens may have been missing many years ago and never removed from the collection. All that remains are the accession or catalog records. For these cases, do as much research and documentation as possible. Deaccession the items using the procedures in this appendix.

L. 3 Reporting Loss

L.3.1 Who is responsible for reporting the loss of museum objects?

The custodial officer for the museum collection:

- reports losses due to vandalism or theft or the loss of a firearm to a park law enforcement officer and the accountable officer (superintendent or center manager) within 24 hours
- documents the loss and the circumstances surrounding the loss
- reports all losses, including museum property located at non-federal repositories, to the regional curator
- coordinates with the Contracting Officer for incidents involving contractors or subcontractors
- provides assistance to the Board of Survey or Survey Officer in determining the value of museum property

L.3.2 How does park law enforcement report losses due to vandalism or theft or loss of a firearm?

Park law enforcement will complete a case incident report. Get a copy of the report and the case number.

The report should show that the missing object is museum property. Provide a copy of the catalog record and other pertinent data from the catalog or accession folder for the report.

Law enforcement will report all thefts and vandalism to:

- local or state law enforcement authorities

- the Federal Bureau of Investigation (FBI), which may choose to conduct an investigation if the property is valued above \$5,000

L.3.3 Should I report stolen museum collections to outside agencies?

The more widely you report a theft, the better chance of recovery. However, notify and consult with NPS and local law enforcement authorities before contacting outside agencies. Park law enforcement may want to handle these contacts, so keep clear lines of communication with them to avoid double reporting.

Refer to Figure L.7.1 for a list of outside agencies that can provide assistance in locating stolen objects.

L.4 Documenting Loss

L.4.1 How do I document a loss?

To document a loss:

- change the Object Status field on the catalog record to Missing.
- enter the fiscal year that you discovered the loss in the Status Date field.
- complete a Report of Survey, Form DI-103 (Figure L.7.2)
- complete the Background section of the Negligence Determination Memorandum (Figure L.7.3)
- follow the new policy DOI-AAAP-0111, Stolen, Lost, Damage, or Destroyed DOI Personal Property. This policy rescinds and replaces IPMD Section 114-60.8 – Survey Procedures. The new policy updates the No Negligence and Simplified Negligence process. It covers DOI museum objects, including those located at non-federal museums/repositories.
- file copies of the case incident report (for vandalism, theft, or firearms) and all other documentation relating to the loss in the appropriate accession and catalog folders.
- deaccession the object(s) using the appropriate reason related to the loss after the Report of Survey is signed

L.4.2 When should I complete the Report of Survey?

For thefts, vandalism, destruction, and any loss of a firearm, complete the Report of Survey within 30 days of discovering the loss.

For missing objects, complete the Report of Survey within six months after discovering the loss. During that time, search for the objects and search the museum records. Many times missing objects have been misplaced and are later found.

L.4.3 Where can I find the procedures for DOI-AAAP-0111?

The new procedures are on the DOI-AAP PORTAL, which you can access from the Office of Acquisition and Property Management Sharepoint site. Go to:

- <https://www.doi.gov/pam/programs/acquisition/pamareg>
- Choose DOI-AAP PORTAL.
- Choose final DOI-AAAP Docs.
- Scroll to DOI-AAP-0111.

L.4.4 What if the object is found?

Change the Object Status field from Missing to the appropriate entry, such as Storage or Exhibit. Note the disappearance and recovery of the object on the catalog record and in the accession folder and catalog folders. Record the condition of the object upon its return.

If the object has been deaccessioned, mark the signed deaccession form and Report of Survey as “Void.” Initial and date these documents. Enter “Void” in the Notes field of the ICMS deaccession record.

L.5 Determining Accountable Action

L.5.1 Who determines accountable action for stolen, lost, damaged, or destroyed museum property?

As the accountable officer, the superintendent determines if a loss is the result of:

- no negligence – the individual is not liable because he/she gave appropriate care to the collection

- simple negligence – the individual is not liable, but he/she did not take as much care of the collection as a reasonably prudent person would have taken under similar circumstances
- gross negligence – the individual is liable due to reckless or deliberate disregard in caring for the collection
- property irregularity and gross negligence – the individual is liable due to 1) repetitive loss of a particular type of museum object or recurring losses at a given location; 2) losses of a suspicious nature; 3) evidence of serious misconduct, such as fraud, falsification of records; 4) known, suspected, or alleged fraud, waste, abuse, or misappropriation of museum property

The superintendent completes the DOI Background and Determination of Personal Property Negligence Memorandum (Figure L.7.3) to document the determination and notifies the Regional Curator and/or Chief Curator and signs the Report of Survey

The superintendent must be recused from making a determination if he/she is involved in the incident. The Regional Director would then make the determination.

L.5.2 What if the superintendent is unable to make a determination?

If unable to decide on the level of negligence, the superintendent contacts the Regional Curator and/or the Chief Curator for assistance.

L.5.3 What documentation does the custodial officer give to the superintendent?

The custodial officer gives the superintendent a sealed envelope with:

- a completed DI-103, Report of Survey, for signature (if gross negligence, the liable individual must sign the form)
- supporting documentation for the DI-103, including catalog records, photographs, incident reports, witness statements, and other relevant evidence
- a copy of the case incident report and any police reports for thefts, ongoing unauthorized use, or vandalism
- the DOI Background and Determination of Personal Property Negligence Memorandum with the Background section completed

L.5.4 What actions are taken for a determination of No Negligence?

For a determination of No Negligence, the superintendent:

- determines the action to be No Negligence and completes the DOI Background and Determination of Personal Property Negligence Memorandum (Figure L.7.3)
- signs and dates the DI-103, Report of Survey, and returns it to the custodial officer

L.5.5 What actions are taken for a determination of Simple Negligence?

For a determination of Simple Negligence, the superintendent:

- determines the action to be Simple Negligence and completes the DOI Background and Determination of Personal Property Negligence Memorandum (Figure L.7.3)
- signs and dates the DI-103, Report of Survey, and returns it to the custodial officer

L.5.6 What actions are taken by the superintendent for a determination of Gross Negligence?

For a determination of Gross Negligence, the superintendent:

- determines the action to be Gross Negligence, including property irregularities, and completes the DOI Background and Determination of Personal Property Negligence Memorandum (Figure L.7.3)
- signs and dates the DI-103, Report of Survey, and designates a Board of Survey or Survey Officer to investigate the incident

LI.6 Determining Gross Negligence

L.6.1 What is a Board of Survey?

A Board of Survey reviews and investigates the loss of museum property due to gross negligence. The Board consists of three or more disinterested individuals that includes one chairperson appointed in writing by the superintendent. Appointments are for at least one year and not more than three years. Board members must be government employees and at least one level above the liable individual(s) in the management chain. They can have no direct interest in the property being investigated.

A Special Board of Survey investigates unusual losses from major incidents, such as fire, flood, earthquakes, and volcanoes. A Special Board of Survey is usually appointed by the Regional Director and should include the Regional Curator.

L.6.2 What actions are taken by the Board of Survey?

The Board of Survey reviews the DI-103, Report of Survey, and documentation and can:

- change the superintendent's determination to No Negligence or Simple Negligence
- return the package to the superintendent for additional information

If the superintendent's determination is gross negligence, the Board of Survey:

- reviews and investigates all circumstances surrounding the loss and completes a report that documents the investigation and provides findings and decisions concerning the loss
- signs and dates the DI-103, Report of Survey, and provides the package to the Reviewing Authority
- determines if financial liability exists and the amount owed in restitution for the loss (with assistance from the custodial officer)
- sends a written notification of the determination to the liable individual(s) to address the Board and provide a written statement of facts regarding the loss within 14 business days
- provides the liable individual(s) with a Notice of Findings and Determinations on a transmittal letter that contains appeal instructions and the reviewed and signed DI-103, Report of Survey, and ensures that the transmittal letter is signed and dated by the liable individual(s)
- refers recommendations to the Contracting Officer, for cases that involve contractors or subcontractors, to determine financial liability
- refers cases involving property irregularities to the Regional Director
- ensures that all individuals involved in the case have signed and dated the DI-103, Report of Survey (Accountable Property Officer; Custodial Property Officer; liable individual(s); Board of Survey Officer(s); Reviewing Authority; and Regional Director, if applicable)
- provides a final, signed copy of the DI-103, Report of Survey, to the superintendent

L.6.3 What actions are taken by the Reviewing Authority?

The Reviewing Authority is not a member of the Board of Survey or the Accountable Officer. He or she is a senior management official at the next higher organizational level than the Accountable Officer. The Reviewing Authority:

- reviews the DI-103, Report of Survey, findings and determination of gross negligence
- signs and dates the DI-103, Report of Survey, and gives copies to the Board of Survey officers
- may request that the Board of Survey reconsider the action for reasons of technical insufficiency or inadequate documentation but cannot overturn the findings or determination
- provides a copy of the Board of Survey to regional and WASO Property Management for cases involving property irregularities
- sends the DI-103, Report of Survey, to the Regional Director if disagreements exist with the Board of Survey or the findings indicate property irregularities

LI.6.4 What actions are taken by the Regional Director?

The Regional Director:

- makes the final determination if there are differences between the Reviewing Authority and Board of Survey
- signs and dates the DI-103, Report of Survey, and returns it to the Board of Survey
- in cases of property irregularities, reviews the findings from the Board of Survey and determines if the case merits referral to the Office of Inspector General

LII.6.5 What actions are taken by the Office of Inspector General (OIG)?

The OIG conducts an investigation and provides a report to the Regional Director (or designee) and the Director, Office of Acquisition and Property Management.

L.6.6 May a liable individual(s) appeal a finding of Gross Negligence?

Yes. A liable individual(s) can submit a Notice of Appeal to the Office of Hearings and Appeals by following the procedures in DOI-AAAP-0111. The superintendent must receive a copy of the notice. The superintendent or custodial officer may request to respond to the appeal.

L.6.7 What actions are taken by the Office of Hearings and Appeals?

The Office of Hearings and Appeals sends a final decision on the appeal to the liable individual(s); the superintendent; and the Director, Office of Acquisition and Property Management.

L.6.8 What actions are taken if a damaged object must be destroyed?

Two individuals must witness the destruction. The superintendent or custodial officer cannot be witnesses. In cases of hazardous materials, the destruction must follow federal, state, and local waste disposal standards.

L.7 List of Figures

Outside Agencies that Report or Search for Lost Objects

Art Loss Register: www.artloss.com/en

Database of stolen art (must register, but law enforcement can get a complimentary account); now includes a Gun Loss Register.

Department of Justice: www.justice.gov/interpol-washington

Does a search for stolen and recovered cultural property.

Federal Bureau of Investigation Art Crime Team:

<https://www.fbi.gov/investigate/violent-crime/art-theft>

The FBI established a rapid deployment Art Crime Team in 2004. The team is composed of 16 special agents, each responsible for addressing art and cultural property crime cases in an assigned geographic region. The Art Crime Team is coordinated through the FBI's Art Theft Program, located at FBI Headquarters in Washington, D.C. Art Crime Team agents receive specialized training in art and cultural property investigations and assist in art related investigations worldwide in cooperation with foreign law enforcement officials and FBI legal attaché offices. The U.S. Department of Justice provides special trial attorneys to the Art Crime Team for prosecutive support.

Since its inception, the Art Crime Team has recovered more than 14,850 items valued at over \$165 million.

Federal Bureau of Investigation National Stolen Art File (NSAF):

<https://www.fbi.gov/investigate/violent-crime/art-theft/national-stolen-art-file>

The National Stolen Art File (NSAF) is a database of stolen art and cultural property. Stolen objects are submitted for entry to the NSAF by law enforcement agencies in the U.S. and abroad. When an object is recovered, it is removed from the database. However, be aware that not all recoveries are reported to the NSAF. If you have information on a work of art in the NSAF, please use the [FBI.gov tip line](https://www.fbi.gov/tip-line) to report it.

Persons and organizations requiring access to the National Stolen Art File should contact their closest FBI Field Office: www.fbi.gov/contact-us/field-offices

Interpol: <https://www.interpol.int/Crime-areas/Works-of-art/Works-of-art/Database>

The database contains only those objects that have been officially reported as stolen by member countries. Only law enforcement agencies may report thefts.

Figure L.7.1. Outside Agencies that Report or Search for Lost Objects

UNITED STATES DEPARTMENT OF THE INTERIOR REPORT OF SURVEY					Page _____ of _____
					Report No.
					Date
A. Originating Office and Telephone No. <i>(include area code)</i>			Accountable Office and Location		
The following items are: <i>(check one)</i> <input type="checkbox"/> Lost <input type="checkbox"/> Stolen <input type="checkbox"/> Damaged <input type="checkbox"/> Destroyed <input type="checkbox"/> Other <i>(specify)</i>			A statement of circumstances involving the identified property is attached.		
			Signature of Accountable Officer:		Date:
ITEM NO.	QUANTITY OR PROPERTY ID NO.	ITEM DESCRIPTION	ORIGINAL ACQUISITION COST (OAC)	CONDITION CODE <i>(See Reverse)</i>	ESTIMATED VALUE
B. To the best of my knowledge the attached statement(s) of circumstances are correct.					
Signature of Cognizant Employee:		Date:	Signature of Custodial Officer:		Date:
C. Board of Survey findings and determinations: A complete statement of Board findings and determinations is attached.			Signature of Board Chairperson:		Date:
Signature of Board Member:		Date:	Signature of Board Member:		Date:
D. Reviewing Authority: <input type="checkbox"/> Approved <input type="checkbox"/> Returned for technical insufficiency <i>(statement attached)</i> <input type="checkbox"/> Disagree with Board of Survey Findings and Determinations <i>(statement attached)</i>			Signature:		Date:
E. Head of Bureau or Office: <i>(required only for disagreement between Board and Reviewing Authority)</i> Statement of resolution:			Signature:		Date:
F. CERTIFICATE OF DISPOSITION/DESTRUCTION					
I certify that the Item(s) No _____ listed above have been destroyed, abandoned, or disposed of as directed by a Board of Survey.					
Official Responsible for Disposition/Destruction:		Title:	Signature:		Date:
Witness Name (for Destruction only):		Title:	Signature:		Date:
G. Adjustment to property records (Property Official Signature):		Date Completed	Financial Official Signature (if Required):		Date Completed

Figure L.7.2. Report of Survey (DI-103)

Memorandum

To:

From:

Subject: Background and Determination of Personal Property Negligence

The purpose of this memorandum is to provide the personal property background and negligence determination for the asset or assets described in the attached DI-103.

Background

Determination

Attachments

DI-103, Report of Survey Form

Figure L.673. Background and Determination of Personal Property Negligence Memo (Sample)

Appendix M: Memorial Items Table of Contents

	<u>Page</u>
A. Overview of Memorial Items	M:1
What are memorial items?	M:1
How does the NPS handle memorial items?	M:1
Why does the NPS consider memorial items to be abandoned?	M:1
Who collects the memorial items left at NPS sites?	M:1
How does the NPS inform the public about what happens to abandoned items?	M:1
B. Management of Memorial Items	M:2
Do all NPS sites collect memorial items?	M:2
What choices does the NPS have for managing memorial items?	M:2
What happens to items that are retained?	M:2
Who decides which items to retain?	M:2
Why doesn't the NPS keep all memorial items as museum collections?	M:2
What happens to items that the NPS does not retain?	M:3
What authority allows the NPS to destroy abandoned items?	M:3
Can the NPS give memorial items to other federal agencies?	M:3
May memorial items retained by the NPS be returned to the person who left them?	M:3
May memorial items be given to NPS museums by other means than leaving them at the site?	M:4
C. Use of Memorial Items	M:4
How does the NPS use memorial items that become part of a museum collection?	M:4
How does copyright law affect the use of memorial items?	M:5
What if a researcher wants to use memorial items in a commercial publication?	M:5
How can the NPS prevent copyright infringement of memorial items used on-line?	M:5
Are there restrictions on certain types of memorial items?	M:5

Appendix M: Memorial Items

A. Overview of Memorial Items

1. *What are memorial items?*

Memorial items are objects left at a NPS site to honor, or pay tribute to, those associated with the site. The site can be a memorial, such as the Vietnam Veterans Memorial or the Flight 93 National Memorial. The site can also commemorate the life and achievements of an individual, such as a presidential site. The items left at these sites are heartfelt remembrances from family, friends, and the general public. For these people, the act of placing the items at the site can be of great significance.

A park may also receive memorial items through the mail with little or no sender information.

Note: This guidance does not cover memorial items or offerings that are left by traditionally associated peoples at culturally significant sites.

2. *How does the NPS handle memorial items?*

The NPS treats all memorial items with respect. However, because these items are voluntarily left at a site, they fall under the Code of Federal Regulations for abandoned property:

- 36 CFR §2.22, Property
- 41 CFR §§ 102-41.80-10241.115, Voluntarily Abandoned Personal Property

The NPS manages all memorial items left at NPS sites as voluntarily abandoned property. However, selected items may become part of a site's museum collection.

3. *Why does the NPS consider memorial items to be abandoned?*

The NPS considers memorial items to be abandoned because they are intentionally and voluntarily left on government property. The owner has given up title to the items by leaving them at the site with no intent to retrieve them.

4. *Who collects the memorial items left at NPS sites?*

Each site determines the staff assigned to collect the items and the schedule for pickup. Schedules are dependent on weather, material type, and the number of items.

5. *How does the NPS inform the public about what happens to abandoned items?*

The NPS uses signs or other information at a site to let the public know that items left at the site will be treated as abandoned property. NPS web sites should also include information about the disposition of abandoned items. Information should include a prohibition on leaving human remains at NPS sites.

B. Management of Memorial Items

1. *Do all NPS sites collect memorial items?*

No. Only a very few NPS sites collect and manage memorial items. The decision to collect these items and manage some of them as museum collections must be made by the Regional Director in a written memo or other written communication. Permission to collect and manage these items must be noted in the site's Scope of Collection Statement (SOCS).
2. *What choices does the NPS have for managing memorial items?*

The NPS may choose to retain or dispose of the items. The receipt of all memorial items is recorded depending on their nature and intended disposition. Common items to be destroyed can be recorded in an inventory list. Unusual or representative examples to be destroyed can be photographed, individually or in groups, as needed. Items retained permanently or for an extended time for consideration should be documented with a receipt for property.
3. *What happens to items that are retained?*

Selected memorial items are accessioned and cataloged into the site's museum collection, and with some site-specific exceptions, become available for research, exhibition, and publication. Staff photographs all items that are retained for the museum collection.
4. *Who decides which items to retain?*

The site superintendent or site manager gives the final approval for which items to retain in the museum collection. Approval is based upon:

 - the Scope of Collections Statement (SOCS) for the site
 - recommendations from the site's Collections Advisory Committee

The Scope of Collections Statement (SOCS) is the document that establishes the types of objects the site should collect. The SOCS may also include provisions for retaining only samples of certain types of items if there are a large number of similar examples. The SOCS is based on the park's mission and the laws and regulations mandating the preservation of collections. Parks that receive memorial items or have the potential for receiving memorial items should specifically address these items in the SOCS. The SOCS is reviewed at least every five years.

The Collections Advisory Committee is chaired by the curator of collections and includes subject matter specialists. The committee reviews potential accessions and makes recommendations regarding acquisitions. Large numbers of items received after an event such as a notable person's death can be reviewed in groups rather than individually.

Parks without a GS-11 curator must include the Regional Curator, or that person's designee, on the committee.
5. *Why doesn't the NPS keep all memorial items as museum collections?*

Keeping all memorial items is not feasible. Museum storage space is limited and costly due to environmental controls, fire suppression, and security systems. Staff to document and manage the items also adds to the cost. Some items cannot be maintained because they are hazardous, detrimental to other collections, attractive to pests, or perishable.

6. *What happens to items that the NPS does not retain?*
- The NPS destroys the items that are not retained as part of the museum collection. These items include but are not limited to:
- food
 - flowers and plants
 - American flags (see note below)
 - containers and vases that are not an integral part of an item
 - commercial or generic items with no direct association to the site
 - items that are unstable or in poor condition
 - items that are redundant after a sample has been retained
 - items that do not fit the site's Scope of Collections
- Note:** See Federal Flag Code: Public Lay 94-344 for disposal guidance on flags. The code does not apply to small replica flags on sticks.
7. *What authority allows the NPS to destroy abandoned items*
- Federal Management Regulation (FMR) § 102-36.305 - 102-36.330 grants government agencies the authority to destroy abandoned property if the property:
- has no commercial value
 - has an estimated acquisition cost of less than \$500
 - will cost more to care for and maintain than its monetary value
8. *Can the NPS give memorial items to other federal agencies?*
- Yes. Memorial items that the NPS does not want to retain may be transferred to another federal agency, such as the Department of Defense. Parks must go through GSA to give memorial items to a private museum or charity.
9. *May memorial items retained by the NPS be returned to the person who left them?*
- There is a 30-day waiting period before abandoned items can become government property. On very rare occasions, an item could be returned during this period. Items could also be returned if proof is presented that the person leaving the item did not legally own it. However, once an item is retained for official use by a federal agency, it loses its status as voluntarily abandoned property and is treated the same as any other government property. Memorial items that become part of a museum collection cannot be returned.

10. *May memorial items be given to NPS museums by other means than leaving them at a site?*

Yes. The NPS can accept donations of items but must ensure that the donation:

- fits the site's Scope of Collection Statement
- is reviewed and recommended by the site's Collections Advisory Committee
- has no restrictions
- includes copyright, if possible

Donations are documented with a deed of gift that is signed by the site superintendent and the donor.

C. Uses of Memorial Items

1. *How does the NPS use memorial items that become part of a museum collection?*

Most memorial items that become part of a NPS museum collection can be used:

- in exhibits at the site
- in on-line exhibits of digitized collections
- in web-catalogs using thumbnail images
- for research
- for interpretive programs
- in loans to other institutions

These uses of museum collections are considered to be fair use under the Copyright Act because they are:

- for teaching
- for private study, scholarship, or research
- non-profit

At some sites, money left at a memorial site can go to a donation box. Consult the Administration Officer for the site.

2. *How does copyright law affect the use of memorial items*
- Although memorial items are considered to be abandoned property, the NPS does not automatically own the copyright to memorial items that are added to the museum collection. Items of particular copyright concern are letters, poems, photographs, and original works of art. For example, the person leaving the letter owned the letter, but the person who wrote the letter owns the copyright.
- In general, leaving original materials in a public place indicates the intent to place them in the public domain. However, leaving a copy rather than the original may indicate the intent to retain copyright. A site cannot assume that copyright is transferred to the NPS when an object is abandoned.
3. *What if a researcher wants to use memorial items in a commercial publication?*
- The researcher has the responsibility for determining the holder of the copyright and getting permission to use the items. Sites must have researchers sign a Copyright and Privacy Restrictions notice and keep the signed notice on file. The Interior Collections Management System (ICMS), or its successor, contains a copy of the notice.
4. *How can the NPS prevent copyright infringement of memorial items used on-line?*
- Sites should take precautions to minimize high resolution copying and downloading capabilities for on-line images of memorial items. A copyright notice can be included with on-line exhibits. Sites should also have a take-down policy in place in the event that someone alleges copyright infringement.
5. *Are there restrictions on certain types of memorial items?*
- Yes. In accordance with the Privacy Act, the NPS restricts the use of memorial items containing Personal Identity Information (PII). All human remains or items containing human remains are restricted from exhibit and research. Human remains left at NPS memorial sites are not retained in memorial collections.

Appendix O: Appraisals

Page

O.1 Appraisals

O.1.1 What is an appraisal?	O:1
O.1.2 When would I want to assign a monetary value to museum objects?.....	O:1
O.1.3 When am I required to get a formal appraisal of museum objects?	O:1
O.1.4 Do all collections have a monetary value?	O:2
O.1.5 What other kinds of value do museum collections have?	O:2

O.2 Monetary Value

O.2.1 What is fair market value?	O:2
O.2.2 What is replacement value?	O:2
O.2.3 Do all objects have a fair market and replacement value?.....	O:3
O.2.4 What makes an object valuable?.....	O:3

O.3 Informal Appraisals

O.3.1 Can I assign values to museum objects?.....	O:4
O.3.2 How should I determine a value for museum objects?	O:4
O.3.3 How can I gain expertise in market values?	O:4
O.3.4 How do I locate subject-matter specialists?	O:4
O.3.5 Must a specialist come to the park to evaluate objects?	O:5

O.4 Professional Appraisals

O.4.1 When do I need to get a professional appraisal?	O:5
O.4.2 How much does an appraisal cost?.....	O:5
O.4.3 Should I do a scope of work for the appraiser?	O:5
O.4.4 What should I do to prepare for the appraiser's visit?	O:6
O.4.5 What should an appraisal report include?	O:6
O.4.6 Can I request changes to an appraisal report?	O:7
O.4.7 Do I need to get more than one appraisal?	O:7
O.4.8 Does the appraiser have to physically examine the objects?	O:7

O.5 Appraisers

O.5.1 What does a professional appraiser do?.....	O:7
O.5.2 How do I find an appraiser?.....	O:8
O.5.3 What should I look for in an appraiser?.....	O:8
O.5.4 What do professional appraisal organizations do?.....	O:9
O.5.5 Are there laws related to appraisers?.....	O:9:

O.6 Re-Appraising Objects

- O.6.1 How often should I re-appraise the objects in my collection? O:10
- O.6.2 How long is a professional appraisal valid? O:10

O.7 Documenting Appraisal Information

- O.7.1 Where do I put appraisal information on the catalog record? O:10
- O.7.2 Where should I keep appraisal reports and other written documentation on monetary value? O:11

O.8 Appraisals and Tax Deductions

- O.8.1 When is an appraisal required for a donation of objects to a museum? O:11
- O.8.2 What IRS form does the donor use to claim a tax deduction? O:11
- O.8.3 Does the IRS require the park to acknowledge the donation on Form 8283? O:11
- O.8.4 What is IRS Form 8282? O:12
- O.8.5 Can I appraise objects for tax deduction purposes? O:12
- O.8.6 Can I refer an appraiser to a donor? O:12
- O.8.7 What if an appraiser inflates the value of a donation? O:12

O.9 Bibliography

Appendix O: Appraisals of Museum Collections

O.1 Appraisals

O.1.1 What is an appraisal?

An appraisal is an expert estimate of the value of something. The term “appraise” means to place a value on, rate, or judge. Appraisals of museum objects usually are made to determine monetary value. Park staff or subject matter experts can provide informal appraisals for park use. An arms-length, qualified appraiser is required for formal appraisals.

O.1.2 When would I want to assign a monetary value to museum objects?

Assigning monetary values to museum objects can be an important part of collections management. You can use monetary values to:

- determine replacement value for insuring outgoing loans
- document that an exchange of museum objects is equitable
- choose which objects will be controlled property
- justify the need for conservation work
- justify protection and preservation actions
- determine loss in case of damage or theft
- confirm purchase price or the monetary value of an acquisition
- document a proposed deaccession

Note: In the case of theft, law enforcement may base the level of investigation on the monetary value of the object.

O.1.3 When am I required to get a formal appraisal of museum objects?

You must get a formal monetary appraisal for objects in an exchange with:

- institutions outside the federal government
- private individuals

Refer to Chapter 6 for information on exchanges.

O.1.4 Do all collections have a monetary value?

Curators and discipline specialists are usually reluctant to give a monetary value to most natural history and archeological collections. However, certain archeology, paleontology, and geology specimens have a monetary value in the current market. For example, dinosaur specimens can have an extremely high value.

A monetary value may be inappropriate for NAGPRA material and other ethnographic items of cultural significance. Consult with the culturally affiliated group before assigning a monetary value to these types of materials.

O.1.5 What other kinds of value do museum collections have?

Museum collections have scientific, cultural, historic, educational, and esthetic value in addition to their monetary value. NPS collections, in particular, have high associative value. The items in NPS collections are associated with the people, events, and natural features that the parks commemorate. These types of values make many museum items irreplaceable and invaluable.

O.2 Monetary Value

O.2.1 What is fair market value?

Fair market value is the price that a willing buyer and seller agree to when there is no pressure to buy or sell. Both the buyer and the seller should have a reasonable knowledge of the item for sale.

Formal appraisals are based on fair market value. Use fair market value to determine if an exchange is equal. Donors use fair market value to determine value for tax deduction purposes.

O.2.2 What is replacement value?

Replacement value is the amount of money you would need to buy a similar item at full retail cost. In the case of replacement value, the owner has no intention of selling the item.

Replacement value is appropriate for most situations in a park, such as:

- including a value on the catalog record
- determining insurance coverage for an outgoing loan
- making management decisions about the collection

Note: The cost of conservation treatment for a site-specific, irreplaceable object may be more than the fair market or replacement value. Keep this point in mind when assigning values for outgoing loans.

O.2.3 Do all objects have a fair market and replacement value?

No. You can usually place a fair market or replacement value on items that frequently appear in auction sales and antique stores. These types of items include artwork, furniture, ceramics, gems, firearms, textiles, coins, jewelry, books, and ethnographic objects. It's much more difficult to place a monetary value on items that have a less active market. For example, certain natural history specimens and archeological items such as soil and lithic samples may possess great historic or scientific value but little or no market value.

O.2.4 What makes an object valuable?

Characteristics that affect object value include:

- artist or maker
- condition
- rarity
- authenticity
- fashion (market demand)
- age
- provenience
- documentation
- historic association
- materials
- quality of manufacture

NPS collections contain many objects with historic association that will affect their monetary value. For example, Theodore Roosevelt's Rough Riders hat will have a higher monetary value because of its association with both an historic person and event.

The condition of an object often affects its value. Missing pieces or visible repairs usually decrease value. Mint condition greatly increases value.

Sometimes the fact that a collection is complete makes it more valuable, such as a collection of 1939 World's Fair bric-a-brac. The completeness of the collection is more valuable than the items within it.

O.3 Informal Appraisals

O.3.1 Can I assign values to museum objects?

Yes. You can assign values to museum objects for some purposes, such as cataloging, identifying controlled property, and outgoing loans. You can't assign values for exchanges outside the federal government, for a donor's tax deduction, or in other cases that require a formal appraisal.

O.3.2 How should I determine a value for museum objects?

An accurate identification of the object is the first step in assigning value. Once you have identified the object, you may need to:

- do research
- check auction catalogs and retail prices for information on market value and demand
- get help from NPS and other museum subject-matter specialists to determine authenticity

Note: Examine the object carefully, and match it as closely as possible to the examples in the auction catalogs and price guides.

O.3.3 How can I gain expertise in market values?

Antique shows, auctions, and educational forums are good places to learn market values. Become familiar with auction catalogs, books on collectibles, and trade journals and newsletters. Price guides offer market values for many types of specialized objects such as dolls, pewter, glass, and furniture. Check price guides at least once a year for changes in market prices.

O.3.4 How do I locate subject-matter specialists?

Other NPS curators or your regional office may be able to refer you to specialists who can authenticate particular types of objects, such as firearms or agricultural equipment. Go online to locate museums with specialized collections. Many curators are willing to help other museums identify material, but most museums do not allow their curators to provide monetary appraisals.

O.3.5 Must a specialist come to the park to evaluate the objects?

No. Physical observation is the best way to evaluate objects, but specialists often can give you information from photographs. Provide a detailed description of the object. Photos must show several views and features such as wear, repairs, and maker's marks. Once you have an expert authentication of an object, you can begin to look for a market value.

O.4 Professional Appraisals

O.4.1 When do I need to get a professional appraisal?

You need a professional, or formal, appraisal for:

- objects of extremely high value or questionable authenticity
- an exchange of museum objects with individuals or institutions outside the federal government
- updating the value of an entire collection
- potential high value purchases or outgoing loans

Note: To determine the value of an entire collection, an appraiser classifies the types of items in the collection. He/she then estimates a value for each category and totals the figures. At times, an appraiser may place a value on each item and total the values.

O.4.2 How much does an appraisal cost?

At one time, appraisers charged a percentage of the total value of the appraised objects. The Internal Revenue Service (IRS) now prohibits appraisal fees based on percentages. Appraisers now charge a per diem or hourly fee. Appraisers working with very high value objects are normally justified in charging a rate commensurate with the value of the objects.

A park may also accept donated appraisal services as long as there is no conflict of interest. Apply the same standards to someone donating services as you would to someone you are paying.

To save on costs, several parks may want to do a joint contract for the services of an appraiser. A region may also administer a contract for appraising objects in various parks.

O.4.3 Should I do a scope of work for the appraiser?

Yes. Services of an appraiser usually include an on-site visit, research, and preparation of a written report. It's a good idea to send the appraiser a written scope of work that includes the:

- date the work is to be done
- fee for the appraisal
- objects to be appraised
- requirement for a final written report

O.4.4 What should I do to prepare for the appraiser's visit?

The following preparations will help make the best use of the appraiser's time:

- Decide whether you want market value or replacement value (see O.2.1 and O.2.2).
- Make sure that the appraiser will have physical access to the objects.
- Supply adequate lighting and a work table/space to examine the objects.
- Have relevant documentation for each object readily available. Documentation should include provenience information, photographs, and catalog records.

O.4.5 What should an appraisal report include?

A professional appraiser's written report should include the following information:

- client's name
- appraiser's name, address, and credentials
- date and place the appraiser viewed the material
- names of consultants
- if the value is fair market or replacement value
- description of the objects that includes, if applicable, condition (including repairs or restoration work), dimensions, materials, style, technique, characteristics, title, date, artist/maker, site of origin, exhibit history, provenience, authenticity, maker's marks, and value

- total value
- basis for the value, such as auction house prices, current state of the market, artist's standing
- signature and date of report
- statement certifying no interest, past, present, or future in the subject property
- appraisal fee with a statement that it is not contingent on the appraised values

For additional information on appraisals. See the Uniform Standards of Professional Appraisal Practice (USPAP) at <http://www.appraisal.foundation.org>.

O.4.6 Can I request changes to an appraisal report?

Yes. Read the appraisal report carefully when you receive it. If the documentation is inadequate or there are factual errors, return the report immediately for adjustment. It's not appropriate to question the values, but you can question the appraiser's evidence or lack of documentation. It's easier to ask for changes in the report before you have paid for it.

O.4.7 Do I need to get more than one appraisal?

You must get two written appraisals for exchanges outside the federal government for objects that are over \$20,000 in value.

For objects over \$5,000, you may want to get more than one appraisal and average the values.

O.4.8 Does the appraiser have to physically examine the objects?

Having the appraiser actually see and handle the objects is the preferred method of conducting an appraisal. However, at times appraisals can be completed from photographs and a detailed written description. The photos must show all aspects of an object, including condition and distinguishing features.

O.5 Appraisers

O.5.1 What does a professional appraiser do?

A professional appraiser is an acknowledged expert who places monetary values on objects for a fee. Appraisers produce written appraisal statements that include:

- a detailed description of the objects

- an appraised monetary value for the objects
- the facts that are the basis for the value

Note: An appraisal must be supported and justified by facts. For example, many appraisers use prices from recent sales of similar objects to determine a value.

O.5.2 How do I find an appraiser?

The geographical location of some parks can make locating an appraiser difficult.

To find an appraiser, contact:

- your regional curator
- other NPS curators
- museum staff from other institutions
- private collectors
- insurance agents
- professional appraisal organizations (see O.5.4)

O.5.3 What should I look for in an appraiser?

You need to make sure that the appraiser you hire is qualified and ethical. The appraisal of museum objects is not a licensed profession. In fact, most appraisers are commercial dealers. You want an appraiser with a good reputation who is impartial and honest. An appraiser must have no past, present, or future interest, monetary or otherwise, in the object being appraised. He/she may not be a previous owner or vendor of the object. Formal appraisals are sometimes called arms-length appraisals because the appraiser acts independently and has no relationship with the objects.

Look for an appraiser who is an expert in the type of collections for which you want an appraisal. If the appraiser doesn't know the material, he/she will have to do additional research that will increase the cost of the appraisal.

Interview potential appraisers and ask about their training, education, experience, specialties, references, and professional memberships. Ask about the resources they use and how they determine comparisons. You'll also want to see an example of their work. Look for appraisal reports that are complete and that show an expert knowledge of the material.

A good appraiser will be objective, professional, and businesslike. He/she will produce a well-documented report that can withstand close scrutiny.

O.5.4 What do professional appraisal organizations do?

The American Society of Appraisers and the Appraiser Association of America provide education and accreditation for appraisers, including periodic recertification. Both associations maintain a directory of certified and accredited appraisers in various categories, such as paintings and other fine arts. These organizations have standards and requirements for their members. However, there are some very good appraisers who are not members of a professional organization.

The Appraisal Foundation is an educational organization that promotes professional practice and provides information of appraisal standards and appraiser qualifications. Their web site at www.appraisalfoundation.org contains information on appraisers and the appraisal process. The Foundation promotes the Uniform Standards in Professional Appraisal Practice (USPAP).

O.5.5 Are there laws related to appraisers?

Yes. The Pension Protection Act of 2006, Pub. L. 109-280, 120 Stat. 780 (2006), provides stricter definitions for a qualified appraisals. The law also defines people who are excluded from being a qualified appraiser.

According to the Act, a qualified appraiser:

- has been designated as a competent appraiser by a recognized professional appraisal organization or has relevant education and at least 2 years of experience
- regularly prepares paid appraisals
- can verify education and experience in valuing the type of objects being appraised
- has not been barred by the IRS for incompetence or violating regulations, according to 31 USC 330(c), within the last three years; however, the IRS does not provide a list of barred appraisers
- does not fit the definition of an excluded individual

The Act defines an excluded individual as:

- the donor or taxpayer claiming the deduction
- the donee

- a party to how the donor acquired the objects
- any person employed by the other excluded persons
- any person related to the other excluded persons
- an appraiser used regularly by the donor or donee who does not appraise for a majority of other clients

O.6 Re-Appraising Objects

O.6.1 How often should I re-appraise the objects in my collection?

Continual fluctuations in the market for antiques and fine arts mean that values don't remain current. You should periodically re-examine the values on your catalog records. Re-evaluations are particularly important in the event of theft. The value on the catalog record will determine the type of police investigation and whether or not there are criminal prosecution charges.

Be especially aware of price fluctuations in “trendy” objects, such as dolls and Civil War material. Price increases on these types of objects can be much higher than you expect.

An appraiser may be willing to update his/her previous appraisal for a minimal fee.

O.6.2 How long is a professional appraisal valid?

Depending on the material, a professional appraisal may be valid for years or only months. For most transactions, such as acquisitions, loans, and deaccessions, you'll want a current appraisal. For most objects in storage, you'll update the value infrequently. Update the values of exhibit items and controlled property more often.

The appraisals that you use in an exchange or donation can't be more than 60 days old.

O.7 Documenting Appraisal Information

O.7.1 Where do I put appraisal information on the catalog record?

Use the Appraisals Supplemental Record in ICMS to document appraisal information on the catalog record. The record allows you to track changes in value and link the appraisal data to the name and address of the appraiser. Refer to the supplemental record section of the *ICMS User Manual* for information on how to enter data in this record.

Information in the Appraisals Supplemental Record does not appear on the ICMS catalog record screens. Acquisition value and current value print on the Museum Catalog Record, Form 10-254 and 10-254B.

O.7.2 Where should I keep appraisal reports and other written documentation on monetary value?

File appraisal information in the accession folder or the outgoing loan folder, deaccession folder, or catalog folder. Since most appraisals are for more than one object, you may have to make copies for multiple accession and catalog folders.

Attach electronic appraisal reports or scans of paper reports to the ICMS catalog or accession record on the Multimedia tab.

O.8 Appraisals and Tax Deductions

O.8.1 When is an appraisal required for a donation of objects to a museum?

Donors can claim a tax deduction for donating objects to a museum. The IRS:

- does not require an appraisal for donations less than \$500
- allows the use of fair market value for donations between \$500 and \$5,000
- requires a formal appraisal for donations that total over \$5,000 in one year

O.8.2 What IRS form does the donor use to claim a tax deduction?

The donor uses IRS Form 8283 Noncash Charitable Contributions to claim a tax deduction. Keep a copy of the form, and file it in the accession folder.

O.8.3 Does the IRS require the park to acknowledge the donation on Form 8283?

Yes. The park must complete the Donee Acknowledgment section (Part IV) of IRS 8283. This section acknowledges that the park:

- qualifies as a charitable organization and has received the donation
- will file IRS Form 8282, Donee Information Return, if the park disposes of the objects within 3 years of the date of receipt
- will or will not use the property for an unrelated use

Note: Signing Form 8283 does not mean that the park agrees with the appraised value.

O.8.4 What is IRS Form 8282?

If you deaccession a donation reported on Form 8283 within three years of receipt, you must report the deaccession to the IRS on Form 8282 Donee Information Return. You must include the donor's tax identification number and send the donor a copy of the form. Keep a copy of the form, and file it in the accession folder.

You don't need to complete Form 8282 if the donation was valued at less than \$500.

Note: It's against NPS policy to acquire an object with the intention of deaccessioning it.

O.8.5 Can I appraise objects for tax deduction purposes?

No. NPS staff cannot give appraisals for tax deduction purposes even on their own time. Providing an appraisal for potential donations is a conflict of interest, since the park is an interested party in the transaction.

O.8.6 Can I refer an appraiser to a donor?

No. You can't refer a specific appraiser to a donor in order to get an appraisal for tax deduction purposes. You can give donors a list of appraisers or refer them to the ASA and other professional associations of appraisers.

Refer donors to IRS Publication 561 Determining the Value of Donated Property at www.irs.gov. This publication explains when appraisals are required, what they should contain, and how the IRS reviews them. IRS Publication 526 Charitable Contributions explains how to claim a deduction for charitable contributions.

Note: IRS requirements are frequently modified, so check the IRS web site when dealing with tax deductions.

O.8.7 What if an appraiser inflates the value of a donation?

The Pension Protection Act of 2006 imposes a penalty on the appraiser and the donor for gross overvaluations. The park should not get involved with reporting an overvaluation. Form 8283 contains a statement that the donee's signature does not mean agreement with the appraised value.

O.9 Bibliography

Buck, Rebecca A. and Jean A. Gilmore. *Museum Registration Methods*, 5th ed. Washington, D.C.: AAM Press, 2010.

Malaro, Marie C. and Ildiko P. Deangelis. *A Legal Primer on Managing Museum Collections*, 3rd ed. Washington, D.C.: Smithsonian Books, 2012.

Appendix N: Reproductions, Period Pieces, Living History Items, Exhibit Props, and Outdoor Exhibits

N.1. Overview

N.1.1	What Information will I find in this appendix?	N:1
N.1.2	What is an original/site-associated item?	N:1
N.1.3	What is a reproduction?	N:1
N.1.4	What is a period piece?	N:1
N.1.5	What are living history materials?	N:2
N.1.6	What is an exhibit prop?	N:2
N.1.7	What is an outdoor exhibit?	N:2

N.2. Reproductions

N.2.1	Why do parks acquire reproductions?	N:2
N.2.2	What kinds of reproductions does the NPS use?	N:3
N.2.3	How are reproductions different from objects in the museum collection?	N:3

N.3. Period Pieces

N.3.1	Why do parks acquire period pieces?	N:3
N.3.2	Can period pieces be used for the same purpose as a reproduction?	N:3
N.3.3	How are period pieces different from original objects in the museum collection?	N:4

N.4. Accessioning and Cataloging Reproductions and Period Pieces

N.4.1	Must I accession and catalog all reproductions and period pieces?	N:4
N.4.2	Who should make the decision about when to accession a reproduction or period piece?	N:4
N.4.3	What should the committee consider when evaluating a reproduction or period piece?	N:4
N.4.4	May I remove reproductions or period pieces that are currently in the collection?	N:6
N.4.5	What if the park has a large number of reproductions to deaccession?	N:7
N.4.6	What about reproductions and period pieces that are used consumptively?	N:7
N.4.7	How will reproductions or period pieces be tracked if they are not cataloged?	N:7

N.4.8	Are there special procedures for documenting reproductions and period pieces that are cataloged?	N:8
N.5.	Living History Items	
N.5.1	Are living history items part of the museum collection?	N:8
N.5.2	How does the park document living history items?	N:9
N.6.	Exhibit Props	
N.6.1	What's the difference between reproductions and exhibit props?	N:9
N.6.2	How should I document exhibit props?	N:9
N.6.3	What if I have exhibit props in my museum collection?	N:10
N.6.4	When should I accession and catalog exhibit props?	N:10
N.7.	Outdoor Exhibits	
N.7.1	Do I catalog objects in outdoor exhibits?	N:10
N.7.2	Do I catalog fixed outdoor structures such as monuments?	N:10
N.7.3	Do I complete a facility checklist for museum items in outdoor exhibits?	N:10
	Decision Checklist	N:11

Appendix N: Reproductions, Period Pieces, Living History Items, Exhibit Props, and Outdoor Exhibits

N.1. Overview

N.1.1 What information will I find in this appendix?

The information in this appendix will help you decide how to document reproductions, period pieces, living history items, exhibit props, and outdoor exhibits. These types of objects are used for exhibitions, education, and interpretation. Although they are used for museum purposes, they are not always accessioned and cataloged into the museum collection. This section will help you determine when to include these types of materials in the museum collection.

N.1.2 What is an original/site-associated item?

An original/site associated item is one that historically belonged to or is connected to the site.

N.1.3 What is a reproduction?

A reproduction is the reconstruction or fabrication of an accurate copy of an original object/item. The original object/item may:

- be too fragile to exhibit
- no longer exist except in photographs or drawings
- not be in the park's collection

A reproduction can be off-the-shelf or custom-made.

Example: the reproduction of Martin Van Buren's dining room table

N.1.4 What is a period piece?

A period piece is an item made during the site's period of significance, but the item has no historic association to the site.

Example: a horsehair-covered footstool from circa 1855 purchased at an antique mall

Period of Significance is the main historical time frame for the site or the time frame chosen as the focus for the site. For example, the period of significance for the Old

House (or Peacefield) at Adams NHP is 1787-1927. John Adams purchased the house in 1787, and the last member of the fourth generation, Brooks Adams, died in 1927.

N.1.5 What are living history materials?

Living history materials are props, reproductions or period pieces acquired specifically for consumptive use by interpreters as part of living history demonstrations or exhibitions.

Example: a wash tub used for laundry demonstrations

Note: Period pieces should only be used consumptively in living history demonstrations when a suitable substitute cannot be found or is cost prohibitive.

N.1.6 What is an exhibit prop?

An exhibit prop has no historic association with the park. It is an item that is added to an exhibition but is only used to enhance interpretation.

Example: artificial apples in a fruit bowl or books acquired only to fill a bookshelf

N.1.7 What is an outdoor exhibit?

Outdoor exhibits consist of an object or collection of objects on public display outdoors. The objects are usually large, such as farm equipment or cannon, and are movable. Fixed monuments are tracked in the List of Classified Structures (LCS). Ships and railroad cars, although movable, are also tracked in the LCS.

Example: cannon on the surrender field at Yorktown

N.2. Reproductions

N.2.1 Why do parks acquire reproductions?

Parks acquire reproductions for exhibits and interpretation. A park may decide to use reproductions when:

- the park does not have the specific items in the collection needed for an exhibit.
- original pieces in the collection are too fragile for exhibit or need to be protected from extended exposure or loss.

Reproducing objects of religious or spiritual significance to a traditionally associated people requires consultation. The park will consult with culturally affiliated or traditionally associated peoples to determine the religious status of any object whose sacred nature is not confirmed (Management Policies 2006, 5.3.5.5.3).

N.2.2 What kinds of reproductions does the NPS use?

Parks use several different types of reproductions in exhibits. These include those:

- available on the commercial market
- created for a specific exhibit installation or by a contractor or park staff
- based on objects from the park's collection or another park's or institution's or private collection

Chapters 4 and 5 in the *Museum Handbook*, Part III, provide additional information on two-dimensional and three-dimensional reproductions, including commercial use.

N.2.3 How are reproductions different from objects in the museum collection?

Although reproductions have monetary and interpretive value, they don't have the associative or site-specific value attached to original/site-associated museum objects. However, in certain cases, reproductions may be the only remaining evidence of the originals. They may also be inherently significant themselves, such as the Navajo rug reproductions at Hubbell Trading Post NHS.

N.3. Period Pieces

N.3.1 Why do parks acquire period pieces?

Parks acquire period pieces for the same reasons they acquire reproductions. Some period pieces may cost less to procure for an exhibit than a reproduction.

N.3.2 Can period pieces be used for the same purpose as a reproduction?

Yes. Period pieces may be acquired to serve the same purpose as a reproduction.

N.3.3 How are period pieces different from original objects in the museum collection?

Although period pieces are from the same time frame as the park, they do not have direct provenance to the park. They have been acquired to substitute for original objects.

Note: Some parks, such as San Francisco Maritime, have scopes related to themes rather than site-specific people and places. Distinguishing between period pieces and original items at these sites can be difficult. Determining what should be accessioned must be made in consultation with the collections advisory committee and the curator of the collection.

N.4. Accessioning and Cataloging Reproductions and Period Pieces

N.4.1 Must I accession and catalog all reproductions and period pieces?

No. Cataloging provides the maximum control and protection for an object. However, maintaining accountability for dozens of reproduction items takes valuable time away from managing the historically important objects in the collection.

Determining whether or not to accession and catalog a reproduction or period piece depends on an evaluation of its purpose and its scientific, cultural, historic, educational, esthetic, or monetary value. Some types of objects can be evaluated as a group. Others, such as rare or expensive custom reproduction textiles or period furniture, may need to be evaluated on a case-by-case basis.

Example: Cannon mounted on reproduction carriages are a common occurrence in military parks. Although carriages are expensive, a park may decide not to catalog them because they deteriorate in outdoor conditions.

N.4.2 Who should make the decision about when to accession a reproduction or period piece?

All accessions of reproductions and period pieces must be reviewed by a collections advisory committee that includes the curator of the collection. Refer to Chapter 6 for information on committee members and procedures.

N.4.3 What should the committee consider when evaluating a reproduction or period piece?

The collections committee should consider a variety of criteria when evaluating a reproduction or period piece. Criteria to consider (in no priority order) include:

- Scope of Collections (SOCS). Does the park SOCS provide guidelines on reproductions and period pieces in the collection? Parks should include a statement about the types of reproductions and period pieces that are included and accepted into the collection.
- Research and educational value. Does the reproduction or period piece add to information about the collection that would be of value for research and education?
- Unique attributes. Does the reproduction or period piece contain unique attributes that complement the existing collection?
- Technical accuracy and workmanship. Is the reproduction or period piece a museum quality piece in its own right?
- Artist or maker. Does the artist or maker of the reproduction have a special association with the site?
- Monetary value. Should the reproduction or period piece be accessioned because it is of high monetary value, which would make it difficult to replace (possible benchmark value of \$5000 or more)?
- Number of objects. If there are a large number of similar reproductions or period pieces, should one or a sample be put in the collection rather than all of them?
- Longevity. Has the reproduction or period piece been in the park for such a long period of time that it could be considered museum material? Clearly mark reproductions or period pieces that are retained in the collection so that future staff do not mistake them for original material.
- Rarity. Would the park have great difficulty in replacing the reproduction or period piece due to technical accuracy and materials?
- Level of documentation. Does the reproduction or period piece have a particularly noteworthy provenance that can justify its inclusion in the collection?
- Intended use. Will the object be used consumptively, such as a reproduction carpet?

- Condition and completeness. Is the reproduction or period piece in good condition with all its component parts?
- Long-term preservation costs. Will the park be able to, or want to, pay for conservation treatment of the object in the future?
- Environment. Is the reproduction or period piece in an environment that does not meet museum standards, such as reproduction bedding on the *USS Cassin Young*?
- Storage space. When the reproduction or period piece is no longer on exhibit, is it an item that the park wants to keep in museum storage? Is there adequate storage space available?
- Interpretive focus. Has there been a change in interpretive focus at the park that would make the reproduction or period piece fit the SOCS?
- Exhibit termination. Does the reproduction or period piece need to be re-evaluated at the termination of an exhibit? Can it be used again/recycled for future exhibits?

Refer to the checklist in Figure 1 to help determine when a reproduction or period piece should be accessioned and cataloged.

N.4.4 May I remove reproductions or period pieces that are currently in the collection?

Reproductions or period pieces that are already cataloged should remain in the collection unless they:

- do not fit the SOCS
- are badly damaged or deteriorated
- there is a strong justification that the items were accessioned in error

Refer to Chapter 6 in this handbook for instructions on deaccessioning objects and documenting the removal of items that were accessioned in error.

A collections advisory committee must review and recommend deaccessions and the removal of non-museum property that has been accessioned in error.

Don't reuse the catalog numbers of reproductions or period pieces that are deaccessioned or removed from the collection as accessioned in error.

N.4.5 What if the park has a large number of reproductions to deaccession?

Parks with large numbers of reproductions already in the museum collection may wish to reevaluate existing collections. The park must have an up-to-date SOCS that specifically addresses reproductions and period pieces. A collections committee must evaluate these items against the factors in this appendix. The Regional Curator must also review and approve the committee's recommendations.

N.4.6 What about reproductions and period pieces that are used consumptively?

The superintendent can request the Regional Director to approve a cataloged reproduction or period piece for consumptive use. At the end of the object's useful life, the object is deaccessioned through a Board of Survey. Refer to the Consumptive Use section in Chapter 6 for information on permission for consumptive use. Generally, reproductions can receive routine approval for consumptive use.

The park may want to determine the disposition of some cataloged reproductions, such as curtains and rugs, which will deteriorate from use over time. At acquisition, note on the catalog record that the object will be destroyed through a Board of Survey at the end of its useful life. Note the final disposition in the Description field on the catalog record and in the accession folder.

N.4.7 How will reproductions or period pieces be tracked if they are not cataloged?

There is no service-wide system for tracking reproductions or period pieces that are not cataloged as part of a museum collection. However, as government property, these objects need to be tracked even if they are not cataloged. A few options include:

- listing reproductions and period pieces used in an exhibit in the Exhibits Module of ICMS (or its successor). The exhibit record for each exhibit can include a list of the uncataloged reproductions or period pieces in that exhibit. Enter the list in the Comments field or one of the User fields.

- tracking reproductions and period pieces through Excel spreadsheets, an Access database, or a park-specific tracking system
- using the personal property system for items over \$5000
- tracking expensive exhibit pieces (such as reproduction furniture) through the Facility Management Software System (FMSS)
- creating a visual inventory system that uses photographs of a case or wall labeled with numbers corresponding to a list of objects

N.4.8 Are there special procedures for documenting reproductions and period pieces that are cataloged?

Yes. Do the following when documenting reproductions and period pieces that are cataloged:

- Add an R or a P to the catalog number that is marked on the object. Clearly and permanently mark the object in an accessible, but not obtrusive, location. Refer to appendix J in this handbook for marking techniques.
- Complete the Reproduction field on the ICMS catalog record, selecting either Reproduction or Period Piece. Include a note in the Description field stating that the object is a reproduction or period piece.
- Use the accession or catalog folder to store any information about the purchase or manufacture of the reproduction or period piece.

N.5. Living History Items

N.5.1 Are living history items part of the museum collection?

No. The park will manage reproductions and period pieces acquired and used for living history separately from the museum collection.

Parks must store living history items in a separate location from the museum collection. However, in some instances, if they are clearly marked, living history items can be part of an exhibit with cataloged collections.

Living history items are not museum property and must be managed according to the personal property system (Director's Order 44) and not entered into ICMS.

Remove living history items that have been inappropriately accessioned into the museum collection. Refer to Chapter 6 in this handbook for information on removing non-museum property from the collection.

N.5.2 How does the park document living history items?

Staff responsible for living history items should clearly and permanently mark them as living history.

N.6. Exhibit Props

N.6.1 What's the difference between reproductions and exhibit props?

Reproductions are exact or close imitations of museum objects. Exhibit props are produced or acquired to enhance an exhibit and are not intended to be museum objects. Examples of exhibit props include:

- molded plastic fruit or food, candles, Christmas decorations
- product boxes and cans to use as shelf fillers in a store
- panels and dioramas
- display panels
- photographs and other display art, graphics, and text labels
- mannequins and other types of museum supports

N.6.2 How should I document exhibit props?

Don't accession and catalog exhibit props (see 6.4 for rare exceptions). Clearly and permanently mark exhibit props as "Exhibit Prop" or "Prop." Mark them in an accessible, but not obtrusive, location. Track them in the same method the park uses for other uncataloged reproductions.

N.6.3 What if I have exhibit props in my museum collection?

Remove exhibit props that have been inappropriately accessioned into the museum collection. Refer to Chapter 6 in this handbook for information on removing non-museum property from the collection.

N.6.4 When should I accession and catalog exhibit props?

In rare cases, you may want to accession and catalog old exhibit props as examples of:

- notable craftsmanship or maker
- the history of the park
- exhibit techniques or interpretive approaches

N.7. Outdoor Exhibits

N.7.1 Do I catalog objects in outdoor exhibits?

Accession and catalog movable objects in outdoor exhibits if they:

- fit the park's SOCS
- possess scientific, cultural, historic, educational, esthetic, or monetary value and have a direct tie or association to the site

Examples include cannon, farm equipment, and automobiles.

N.7.2 Do I catalog fixed outdoor structures such as monuments?

No. The List of Classified Structures (LCS) defines fixed outdoor monuments as historic structures. NPS-28 *Cultural Resource Management Guideline* defines historic structures as “usually immovable, although some ...are mobile by design.” They include monuments, nautical vessels, railroad locomotives, and outdoor sculpture.

If pieces of fixed historic structures become detached and cannot be reattached, accession and catalog them as you would architectural elements.

Note: Some large movable outdoor items such as ships and train cars are on the LCS and also cataloged. This determination is made by the park.

N.7.3 Do I complete a facility checklist for museum items in outdoor exhibits?

No. Do not do a facility checklist for outdoor exhibits. Designate the items in outdoor exhibits as controlled property so that they are part of the annual inventory.

Decision Checklist

The collections committee can use this optional checklist to make decisions about including reproductions and period pieces in the museum collection.

Y N

Scope of Collections. Does the park SOCS provide guidelines on reproductions/period pieces in the collection?

Research and educational value. Does the reproduction/period piece add to information about the collection that would be of value for research and education?

Unique attributes. Does the reproduction/period piece contain unique attributes that complement the existing collection?

Technical accuracy and workmanship. Is the reproduction/period piece a museum quality piece in its own right?

Artist or maker. Does the artist or maker of the reproduction have a special association with the site?

Monetary value. Should the reproduction/period piece be accessioned because it is of high monetary value, which would make it difficult to replace (possible benchmark value of \$5000 or more)?

Number of objects. If there are a large number of similar reproductions/period pieces, should one or a sample be put in the collection rather than all of them?

Longevity. Has the reproduction/period piece been in the park for such a long period of time that it could be considered museum material? Clearly mark reproductions/period pieces that are retained in the collection so that future staff do not mistake them for original material.

Rarity. Would the park have great difficulty in replacing the reproduction/period piece due to workmanship and materials?

Level of documentation. Does the reproduction/piece have a particularly noteworthy provenance that can justify its inclusion in the collection?

Intended Use. Will the objects be used consumptively, such as a reproduction carpet?

Condition and completeness. Is the reproduction/period piece in good condition with all its component parts?

Long-term preservation costs. Will the park be able to, or want to, pay for conservation treatment of the object in the future?

Environment. Is the reproduction/period piece in an environment that does not meet museum standards?

Storage space. When the reproduction/period piece is no longer on exhibit, is it an item that the park wants to keep in museum storage? Is there adequate storage space available?

Interpretive focus. Has there been a change in interpretive focus at the park that would make the reproduction/period piece fit the SOCS?

Exhibit termination. Does the reproduction/period piece need to be re-evaluated at the termination of an exhibit? Can it be used again/recycled for future exhibits?

Figure 1: Decision Checklist (optional)

MUSEUM HANDBOOK



PART III

MUSEUM COLLECTIONS USE

INTRODUCTION

The *Museum Handbook* covers a broad range of topics to guide National Park Service staff in managing museum and archival collections:

- Part I covers planning, preservation, and protection for the disciplines and materials represented in NPS collections, including professional ethics, specialized storage, environment standards, conservation treatments, and emergency preparedness.
- Part II outlines procedures for museum record keeping, including accessioning, cataloging, loans, deaccessioning, photography, and reporting annual collection management data.
- Part III provides guidance on access and use for interpretation, education, exhibition, and research. It covers legal issues, publications, two and three-dimensional reproductions, using museum objects in exhibits and furnished historic structures, and providing access for research.

NPS staff responsible for collections should make informed choices based on their own skills and experience, standards and procedures outlined in the *Museum Handbook*, advice provided by specialists, and additional information provided in the references found in the *Museum Handbook*. Staff should, as needed, seek advice or technical information from support offices, the Harpers Ferry Center, and the Museum Management Program, National Center for Cultural Resources Stewardship and Partnership Programs.

By following the practices represented in this guidance, trained staff can ensure that the National Park Service collections will be, as mandated by the 1916 NPS Organic Act, preserved and maintained for the use and enjoyment of the present and future generations.

Ann Hitchcock
Chief Curator
Museum Management Program
National Center for Cultural Resources
Stewardship and Partnership Programs
September 1998

ACKNOWLEDGMENTS

The NPS *Museum Handbook*, Part III, is coordinated by the Access and Use Team (AUT), Museum Management Program (MMP), National Center for Cultural Resources Stewardship and Partnership Programs. AUT members with contributions from selected NPS and other museum professionals wrote the first three chapters and appendices. AUT members who developed the first three chapters of the new *Museum Handbook*, Part III are Diane Vogt O'Connor, Senior Archivist; Virginia Kilby, Staff Curator; and Joan Bacharach, Museum Curator. AUT members Joan Bacharach and Diane Vogt O'Connor wrote the chapters on two and three-dimensional reproductions, and other uses of museum collections. Joan Bacharach coordinated the project. Cynthia Murdock, Program Assistant, MMP, assisted with the layout and final editing. Chapters on using museum collections in exhibits, furnished historic structures, and research are being developed.

Museum Handbook, Part III authors are:

Chapter 1: Virginia Kilby, Diane Vogt O'Connor, and Joan Bacharach. Jane Gray, Ethnographer, Archeology and Ethnography Program, National Center for Cultural Resources Stewardship and Partnership Programs (Section E) and Sandy Weber, Interpretive Specialist, Division of Interpretation, Washington Office (Section H) contributed to the chapter.

Chapter 2: Diane Vogt O'Connor

Chapter 3: Diane Vogt O'Connor and Joan Bacharach (Sections G, and I). Brian Jones, Chief, Division of Audiovisual Arts, Harpers Ferry Center (Section G), and Tom Valentine, Chief, Audio-Visual Services, National Gallery of Art (Section I) also contributed.

Chapter 4: Diane Vogt-O'Connor

Chapter 5: Joan Bacharach

Chapter 6: Joan Bacharach

Appendix A: Diane Vogt O'Connor

Appendix D: Donald Cumberland, Museum Specialist, MMP

The authors offer a special note of appreciation to Lorrie Castaneda, Editorial Experts, Inc.; Melissa Cronin, Chief, Publications Division, Harpers Ferry Center, National Park Service; Al Gardiner, Mammalogy Department, National Museum of Natural History, Smithsonian Institution; Bob Groves, Supervisor of Digital Imaging Services, National Gallery of Art; Brian Jones, Chief, Division of Audiovisual Arts, Harpers Ferry Center, National Park Service; Martha Lee, Museum Technician, Yosemite National Park; Melissa Smith Levine, National Digital Library, Library of Congress; Edward McManus, Metals Conservator, National Air and Space Museum, Smithsonian Institution; Walt Meshaka, Curator, Everglades National Park; Carla Mattix, Department of the Interior, Office of the Solicitor; Dave Nathanson, Chief, Library and Archival Services, Harpers Ferry Center, National Park Service; and Tom Valentine, Chief, Audio-Visual Services, National Gallery of Art, for their contributions to this Handbook.

Members of the NPS *Museum Handbook* Steering Committee who guided an early version of the Handbook outline from 1991 to 1993 are Michele Aubry, Senior Archeologist, Anthropology Division, Washington Office; Betty Browning, Museum Curator, Valley Forge National Historical Park; John Brucksch, Staff Curator, Historic Furnishing Division, Harpers Ferry Center; Dan Chure, Paleontologist/Curator Dinosaur National Park; Trinkle Jones, Archeologist, Western Archeological and Conservation Center; Dale Durham, Regional Curator, Southeast Region; Steve Harrison, Deputy Regional Curator, Southeast Regional Office; Diane Nicholson, Museum Curator, Golden Gate National Recreation Area; Sarah Olson, Chief, Historic Furnishings Division, Harpers Ferry Center; Carolyn Rose, Senior Research Conservator, National Museum of Natural History, Department of Anthropology, Smithsonian Institution; Virginia Salazar, Regional Curator, Southwest Regional Office; Jim Thomson, Regional Archeologist, Pacific Northwest Regional Office; Sandy Weber, Interpretive Specialist, Division of Interpretation,

Washington Office; and Tony Knapp, Staff Curator and committee coordinator, Virginia Kilby, Staff Curator, and Ann Hitchcock, Chief Curator, Washington Office, ex-officio members. Members are listed by the institutions where they worked during their term of office on the committee.

TABLE OF CONTENTS

	<u>Page</u>
INTRODUCTION.....	iii
1. EVALUATING AND DOCUMENTING MUSEUM COLLECTIONS USE	
A. Overview	1:1
B. Evaluating Proposed Use of Collections.....	1:2
C. Management Issues.....	1:5
D. Ethical Issues.....	1:13
E. Cultural Issues	1:26
F. Scientific Issues	1:36
G. Preservation and Protection Issues	1:39
H. Interpretation Issues.....	1:49
I. User Qualifications	1:51
J. Documentation	1:53
K. Checklist: Evaluating a Request to Use Museum Objects.....	1:55
L. Bibliography	1:57
2. LEGAL ISSUES	
A. Overview	2:1
B. Access and Use Legislation.....	2:5
C. Copyright Laws	2:6
D. Freedom of Information Act	2:25
E. Location Information.....	2:28
F. Privacy and Publicity Legislation.....	2:31
G. Other Legal Issues	2:38
H. Patent Laws	2:40
I. Trademarks and Servicemarks	2:41
J. List of Figures.....	2:42
K. Bibliography	2:51
3. PUBLICATIONS	
A. Overview	3:1
B. Legal Issues Specific to Publications Using Museum Collections	3:4
C. User Requirements	3:4
D. Documentation	3:8
E. General Information on Producing a Publication	3:9
F. Producing Paper Media.....	3:37
G. Producing Moving Images	3:50
H. Producing Multimedia.....	3:55
I. Producing Sound Recordings	3:60
J. Identifying and Developing Special Skills	3:65
K. Annotated Selected Bibliography	3:68
L. List of Figures.....	3:71
4. TWO-DIMENSIONAL REPRODUCTIONS	
A. Overview	4:1
B. Preliminary Policy and Planning Considerations	4:17
C. 2-D Reproductions Management Implementation Issues.....	4:39
D. Glossary	4:58
E. Selected Bibliography	4:63
F. List of Figures.....	4:68

5. THREE-DIMENSIONAL REPRODUCTIONS

A. Overview	5:1
B. Preliminary Policy and Planning Considerations	5:4
C. Reproductions for NPS Purposes	5:7
D. Reproductions for non-NPS Purposes.....	5:10
E. Reproduction Agreements	5:11
F. Developing a Standard Operation Procedure for Reproductions by NPS and by Agreement with Others	5:17
G. Producing a Reproduction	5:19
H. Selected Glossary	5:23
I. Selected Bibliography	5:24
J. List of Figures.....	5:25

6. OTHER USES OF MUSEUM COLLECTIONS

A. Overview	6:1
B. Management Concerns.....	6:2
C. General NPS Policy on Filming and Photography	6:8
D. Filming and Photography in Spaces Housing Museum Collections	6:9
E. Special Events in an Exhibit and Other Spaces Housing Museum Collections.....	6:13
F. Museum Objects in Working Order.....	6:18
G. Museum Objects Used in Performances, Sound Productions or Demonstrations	6:23
H. Other Uses of Museum Objects in Educational, Interpretative and Other Programs and Activities	6:25
I. Selected Bibliography	6:29
J. List of Figures.....	6:29

7. USING MUSEUM COLLECTIONS IN EXHIBITS

A. Overview	7:1
B. Finding Background Information	7:2
C. Getting Started.....	7:7
D. Defining the Purpose and Audience	7:12
E. Planning and Designing Exhibits	7:17
F. Producing and Installing Exhibits	7:23
G. Exhibit Planning, Design, Production, and Installation Documents	7:25
H. Exhibit Conservation	7:27
I. Preserving and Protecting Objects in the Exhibit Process.....	7:30
J. Exhibit Case Design.....	7:36
K. Traveling and Non-NPS Initiated Exhibits.....	7:39
L. Exhibit Funding and Outreach	7:41
M. Documenting Collections on Exhibit	7:45
N. Evaluating Exhibits.....	7:49
O. Maintaining Exhibits	7:52
P. Rehabilitating Exhibits.....	7:56
Q. Selected Bibliography	7:57
R. List of Figures.....	7:58

8. USING MUSEUM COLLECTIONS IN HISTORIC FURNISHED STRUCTURES

A. Overview	8:1
B. Finding Background Information to Furnish a Historic Structure	8:4
C. Getting Started.....	8:8
D. Planning Historic Furnishings Projects	8:12
E. Producing and Installing Historic Furnishings	8:21
F. Preservation and Maintenance	8:25
G. Documenting Historic Furnishings on Exhibit	8:30

	<u>Page</u>
H. Interpreting Furnished Historic Interiors.....	8:32
I. Evaluating Historic Furnishings.....	8:35
J. Rehabilitating Historic Furnishings Installations.	8:37
K. Selected Bibliography.	8:37
L. List of Figures.....	8:39

APPENDICES

	<u>Page</u>
A. PUBLICATIONS GLOSSARY	A:1
B. GUIDANCE ON PLANNING FOR A RESEARCH SPACE	
A. Research Space Definition and Use	D:1
B. Research Space Standards	D:2
C. Security	D:2
D. Environmental Conditions	D:3
E. Space Issues.....	D:4
F. Researcher Staging Area.....	D:4
G. Equipment for Research Space	D:5
H. Access for Researchers with Disabilities	D:5
I. Utilities.....	D:6
J. Planning for Research Space in a New Facility	D:6
K. Upgrading Your Facility for Research Space.....	D:6
L. Using the Research Space	D:8

LIST OF FIGURES

Figure Number	Caption	Page
2.1	Access and Use Legal Action Chart	2:43
2.2	Sample License Agreement.....	2:50
3.1	Master Checklist for Publication Project (Sample) [Optional].....	3:72
3.2	Intellectual Property Permission Request (Sample) [Optional]	3:75
3.3	Research Sheet (Sample) [Optional].....	3:76
3.4	Assignment of Copyright by Contractor (Sample)	3:77
3.5	Cooperative Publishing Agreement (Sample) [Optional].....	3:78
3.6	Model Release Form 1	3:80
3.7	Model Release Form 2	3:81
3.8	Paper Printing Job Organizer (Sample) [Optional]	3:82
3.9	Museum Management Program Editing Checklist (Sample) [Optional]	3:84
3.10	Museum Management Program Proofreaders' Checklist (Sample) [Optional].....	3:87
3.11	Digital Publication Project Checklist (Sample) [Optional]	3:89
3.12	Memorandum of Agreement (Sample) [Optional].....	3:97
3.13	Selected Foundations that Fund Publications	3:101
4.1	How to Select an Appropriate Process or Format of Reproduction for each Reproduction Purpose or Function.....	4:69
4.2	Reproduction Order Notification Sheet.....	4:70
4.3	Comparison of the Advantages and Disadvantages of 2-D Copy Formats (Sample)	4:71
4.4	2-D Reproductions Cost Recovery Chart for Estimating Time Spent (Sample)	4:76
4.5	Cost-recovery Fees Formula (Sample).....	4:77
4.6	Permission to Publish Letter (Sample)	4:78
4.7	Wording to be Included in a 2-D Independent Contractor Agreement (Sample).....	4:79
5.1	Sample Wording to Include in a Contract between the NPS and a Contractor when a Reproduction is to be Made for In-house Use.	5:25
5.2	Sample Wording to Include in an Agreement Authorizing the Park Cooperating Association to Produce Three-dimensional Reproductions on Behalf of the Park.	5:27
5.3	Sample Wording to Include in an Agreement between the Park and an Organization to Produce a Three-dimensional Reproduction for Sale and Distribution.	5:31
5.4	Sample Wording to Include in a Contract between the Park and a Contractor to Produce a Three-dimensional Reproduction for Sale and Distribution.	5:35
6.1	Hold Harmless or Liability Clause to be Included in a Special Use Permit	6:30
6.2	Documents Needed for Other Uses of Museum Objects.....	6:31
6.3	Sample Conditions to Attach to a Special Use Permit in Spaces Housing Museum Collections.....	6:32
7.1	Sample Wording for a Park Project Agreement with Harpers Ferry Center, Department of Exhibits.....	7:59
7.2	Sample Fabrication and Installation Contract Wording.....	7:64
7.3	Park Exhibit Checklist.....	7:68
7.4	Exhibit Conservation Checklist.....	7:72
8.1	Checklist for Exhibit Museum Collections in a Furnished Historic Interior.....	8:40
8.2	Checklist for Preventive Object Conservation in Historic Furnished Interior.....	8:44
8.3	Sample Agreement between Harpers Ferry Center, Department of Planning and Research and a Park.....	8:47

	<u>Page</u>
8.4	Annotated Guidelines for Preparing Historic Furnishings Report prepared by HFC, Department of Planning and Research.....8:51
8.5	Determining the Cost of Furnishing Historic Interiors based on a HFC, Department of Planning and Research Document.....8:53
8.6	Outline of Recommended Practices for Historical Furnished Interiors adapted From “Standards for Preservation & Guidelines for Preserving Historic Furnished Interiors” of the NPS Northeast Region’s Guidelines.....8:55

Chapter 1: Evaluating and Documenting Museum Collections Use

A. Overview	1:1
What is meant by access to collections?	1:1
How may museum collections be used?	1:1
What information does this chapter cover?	1:2
B. Evaluating Proposed Use of Collections	1:2
Why do I need to evaluate requests to use museum collections?	1:2
What should I do before researchers arrive?	1:2
What restrictions govern the use of museum collections?	1:2
Who can use collections?	1:3
How does an interested party make a request to use the collections?	1:4
How do I assess a request to use museum collections?	1:4
What issues do I consider when evaluating a request for use?	1:4
C. Management Issues	1:5
Who evaluates a request to use museum collections?	1:5
What management concerns determine use?	1:5
What NPS procedural guidelines cover using museum collections?	1:7
What data do I need to restrict?	1:8
What do I need to know about consumptive use?	1:9
What do I need to know about the chain of custody?	1:12
What do I need to know about hazardous materials and chemical contamination?	1:12
How do I establish and implement a park access and use policy?	1:13
D. Ethical Issues	1:13
What ethical issues affect access and use of NPS museum collections?	1:13
What is equal access and how do I provide it?	1:13
What are ethical standards of civility and professional cooperation?	1:15
What is scholarly integrity and what role does it play in providing access to collections?	1:18
How do privacy, confidentiality, and related restrictions affect my conduct?	1:19
What role should preservation play in NPS ethical values?	1:21
What do I need to know about employee ethics?	1:25
What do I need to know about professional ethics?	1:26
E. Cultural Issues	1:26
What cultural concerns affect use?	1:26
How do I identify the concerned parties?	1:27
How does NAGPRA affect collections access and use?	1:28
How does the Executive Order 13007—Indian Sacred Sites affect access and use?	1:28
What are the traditionally associated groups' concerns about access and use?	1:29
What limitations may apply to access and use?	1:30
What are some factors in determining access to and use of cultural materials?	1:30
How does the use context affect cultural concerns about access and use?	1:31
What cultural issues may arise when the general public uses a collection?	1:32
What concerns affect how traditionally associated groups use museum collections?	1:32
What cultural concerns affect the use of natural history collections?	1:33
What other concerns may the traditionally associated groups have?	1:34
When must I be sensitive to the concerns of traditionally associated groups?	1:34
What do I do if I can't grant a traditionally associated group's request?	1:35
What religious concerns must I consider?	1:35
F. Scientific Issues	1:36

What is a natural history type specimen?.....	1:36
What do I need to know about the use of type specimens?.....	1:36
What are voucher specimens?.....	1:37
What do I need to know about the use of voucher specimens?.....	1:37
What do I need to know about the use of threatened and endangered species?.....	1:37
What do I need to know about access to information about threatened and endangered species?	1:38
G. Preservation and Protection Issues	1:39
How do I balance preservation and use?	1:39
How do I preserve collections?.....	1:39
How do I allow access to and use of collections?	1:40
What steps are necessary for providing access to and use of collections without critically affecting collection preservation?	1:41
How do I assess physical condition?.....	1:42
How do I assess physical and mechanical preservation risks associated with the proposed use and how can I prevent damage?	1:43
What are the chemical risks and how can they be avoided?	1:44
What are the biological risks and how can they be avoided?.....	1:44
What are the security risks associated with the proposed use?	1:45
How do I prevent security problems?	1:46
How do I deal with a disturbed, thieving, or destructive individual?.....	1:47
How do I deal with staff theft?	1:48
How do I use a facilities report to evaluate risk?	1:48
How do I protect objects from overuse?.....	1:48
What do I do if objects are damaged?	1:49
How do I recognize over-use?.....	1:49
H. Interpretation Issues	1:49
What is NPS interpretation?	1:49
What is the NPS interpreter's role in using museum collections?.....	1:49
How do I determine the appropriateness of the proposed use?.....	1:50
Are there alternatives to using the proposed object?	1:51
I. User Qualifications.....	1:51
What credentials must users present when requesting access to collections?	1:51
How would the user's qualifications affect an access request?	1:52
J. Documentation	1:53
How do I document access and use of collections?.....	1:53
When should I use an outgoing loan agreement?.....	1:54
K. Checklist: Evaluating a Request to Use Museum Objects.....	1:55
L. Bibliography.....	1:57

CHAPTER 1: EVALUATING AND DOCUMENTING MUSEUM COLLECTIONS USE

A. Overview

National Park Service museums are responsible for properly preserving, managing, and providing access to their collections. NPS collections support, strengthen, and document the parks' cultural and natural history. To use collections effectively for interpretation, education, exhibition, and research, parks must provide both physical and intellectual access to collections.

Both preservation and use are fundamental to a successful NPS museum program. Collections are maintained because of their value to the park, NPS programs, and the general public. Neither preservation nor use are absolute values. Don't give one preference over the other. If you make informed decisions based on NPS policies and procedures, you'll be able to effectively manage and balance both preservation and use without significant compromises.

Park museum collections are an extraordinary resource. As a manager of park collections, you should make every effort to bring the tangible and intangible values embodied in these collections to the public.

1. *What is meant by access to collections?*

Good museum collections management makes collections accessible. Collections access can mean physical access to the museum facility and the collections or intellectual access to the available documentation and background data on the objects.

Providing access to museum collections supports your park's goals by:

- attracting scholars to research and write about your park's history as well as your cultural and natural resources
- encouraging publications, exhibitions, and similar works on your park or program
- developing a constituency of scholarly, international, heritage tourism and other public supporters of your collections who will speak for increased park resources for preservation and access
- helping you locate potential collaborators, cooperators, and partners in your work
- raising the profile of the park in the public's mind in a positive fashion

2. *How may museum collections be used?*

Collections may be used for:

- **publications:** journals, books, films, video, multimedia, and sound recordings
- **exhibitions:** furnished historic structures; museum, outdoor and in-situ

exhibits; visible storage; and media exhibits online or on CD-ROM

- **interpretation and education:** demonstrations and park, classroom, and long distance (via World Wide Web) education programs
- **research:** using both objects and documentation and material analysis
- **reproductions:** facsimile products; reproductions for sale; and preservation, deposit, and security copies (provided as alternatives to the original for use)
- **derivative works:** posters, T-shirts, postcards, reproductions, World Wide Web variants, games, toys, and coloring books

3. *What information does this chapter cover?*

In this chapter you will find information that will help you evaluate proposed uses of your collections and document access to the park's museum and archival collections. You will learn how to assess a request to use your park's museum collections.

A checklist to help you evaluate a request is provided. For a listing of NPS procedural guidelines that cover use of museum collections, see Section C, Management Issues.

B. Evaluating Proposed Use of Collections

1. *Why do I need to evaluate requests to use museum collections ?*

When you receive a request to use the collections, you need to obtain specific information about the proposed use, what access is required, research methodology, and which objects or collections will be used. Often researchers won't know what specific materials are in the collection and can provide only generic information on their needs. Review researchers' requests to use the objects to ensure the proposed use won't violate any laws; or ethical, cultural, or scientific concerns; or any management requirements associated with the use.

2. *What should I do before researchers arrive?*

Examine the objects and determine whether they can be used without risk of destruction or damage. Evaluate whether the objects can be used without compromising their security. Determine if their proposed use conflicts with any federal or state laws. Determine if the use will promote visibility for collections and further the mission of the park.

3. *What restrictions govern the use of museum collections?*

All data, information and collections, except those restricted by law or in accordance with NPS policy, are available to all. Allow only controlled access to a park's museum collection. When you grant permission for access to a user, follow procedures for using the collection and the research space, based on the park's access and use policies. Supervise researchers continuously. Clearly define visitor hours and public areas. Restrict access to all areas that house collections. Security, locked doors, and escorts are essential in non-public areas. For a summary of laws governing access to collections refer to *MH-III*, Chapter 2, Legal Issues.

Access guidance based on management, ethics, cultural considerations, scientific concerns, preservation, protection, and documentation are discussed in this chapter

4. *Who can use collections?*

Anyone can use NPS collections if the use conforms to NPS policies and guidelines. Users may include qualified NPS personnel, artists, contractors, historians, researchers, scientists, and the general public. Institutions and individuals may use park museum collections upon approval from the museum staff designated by the superintendent or center chief. Collections are open to researchers based on the park's written access and use procedures.

- Collections may be approved for non-commercial use:
 - when staff supervision is available, the requested collections are accessioned and cataloged, and the collections are appropriately stabilized
 - when individuals request access for research or study
 - when NPS staff, contractors, or cooperators on official NPS business request use of collections
 - when the NPS requests work (for example, conservation or reformatting) on an object

The object may be loaned to an individual (for example, a contractor) for that work. Otherwise outgoing loans of NPS museum collections are only made to institutions, in accordance with *Museum Handbook*, Part II (*MH-II*), Chapter 5, Outgoing Loans.

- Collections may be approved for non-commercial institutional use:
 - when parks loan collections to nonprofit educational, cultural, or scientific institutions (for example, museums, historical societies, and universities) for exhibition, long-term management, research, and/or photography
 - when representatives of Indian tribes, native Hawaiian organizations, or Alaskan corporations request access to archeological or ethnographic objects associated with their tribes
- Collections may be approved for commercial use:
 - when individuals or representatives of organizations, institutions, or corporations request collections or documentation for legitimate commercial or publicity purposes that are in keeping with park purposes and the NPS mission and don't conflict with legal restrictions such as copyright or privacy legislation or cause significant damage to the item (See Section C, Management Issues, for further guidance.)

5. *How does an interested party make a request to use the collections?* An interested party can make an appointment by phoning, writing, faxing, e-mailing, or visiting the park curator. See Section I, User Qualifications.
6. *How do I assess a request to use museum collections?* When you receive a request for access to collections, use the checklist in Section K and the Conditions for Access to Museum Collections in *Museum Handbook*, Part I (*MH-I*), Appendix G, Figure G.7, to help you evaluate the request. Evaluate requests based on the park's ability to provide access according to law and policy.
- You must consider all requests in an equitable manner, whether from staff, outside scholars, or the general public.
- All access requests should be:
- acknowledged
 - documented through the use of appropriate forms (See Section J, Documentation.)
 - treated with courtesy and respect
- Notify researchers promptly if their requests have been approved or not approved. Provide them with information on the park hours, address, parking, and other pertinent information.
7. *What issues do I consider when evaluating a request for use?* You must consider all of the following issues:
- legal
 - management
 - ethical
 - cultural
 - scientific
 - preservation and protection
 - interpretation
 - user qualifications
- Legal issues are addressed in *MH-III*, Chapter 2. The other issues are discussed in this chapter.

C. Management Issues

1. *Who evaluates a request to use museum* As the manager of the collections, you are delegated by the superintendent to evaluate all requests to use NPS museum collections. You must evaluate

collections?

all requests fairly and equally. Establish a museum collection committee to evaluate requests and assist in developing standard operating procedures for access and use, such as publication, duplication, and research requests. See *MH-I*, Appendix G, Protection of NPS Museum Collections, Figure G.7, and *MH-II*, Appendix D, Museum Archives and Manuscript Collections. All loans must be approved by the superintendent.

2. *What management concerns determine use?*

As a museum professional, you should encourage access to and use of collections and their data. You need to balance preservation and protection with providing physical and intellectual access to the collections. You must implement the requirements outlined by NPS policies and procedures, while adhering to professional museum standards, ethics, and the law. For additional information on museum and professional ethics, refer to Section D, Ethical Issues; for information on legal issues, see *MH-III*, Chapter 2, Legal Issues.

Consider the following when evaluating a request:

- Will the user be adequately supervised?

Make sure users will be continuously supervised. You or your staff should take the selected materials to the research room and monitor researchers while they work. You should have sufficient staff to provide the objects, monitor researchers, and respond to their needs. You also should document all materials used. ***Your access hours don't have to be extensive but must be continuously supervised.*** If staffing is an issue, limit access to certain predetermined times during work hours.

Well-supervised access reflects a well-managed collection. Refer to *MH-I*, Chapter 9, Museum Collections Security and Fire Protection, and Appendix G, Protection of NPS Museum Collections, and *MH-II*, Appendix D, Museum Archives and Manuscript Collections.

- Will users have sufficient space?

Assign a research room for users to view and study museum objects. The room should be outside the collections storage area. See *MH-III*, Appendix D, Guidance on Planning for a Research Space, and *MH-I*, Appendix F, NPS Museum Collections Management, which direct museum storage to be separate from all other uses.

A research room also can be an appropriate shared space outside storage where the user can work. It should be a room close to the curatorial staff workspace. This proximity allows you to supervise users easily and answer their questions.

You might use the park library reading room if no other space is available. Refer to *MH-III*, Appendix D, for additional information on using research spaces.

Never leave a researcher unmonitored in areas with collection materials.

- Are the materials accessioned and cataloged?

All collections should be accessioned and cataloged prior to use. This way you can track what collections are used and ensure greater accountability and security. If you allow access to and use of unaccessioned and uncataloged collections, you are exposing them to great risk, as you can't prove they are NPS property if they are stolen or damaged. You must make every effort, in accordance with *MH-II*, Chapter 2, Accessioning, and Chapter 3, Cataloging, to accession and catalog collections to make them available for use. Accession and catalog data also provide context, collection provenance or history, object provenience, and research information that are extremely valuable to the user. A catalog record greatly helps the user's research.

- Are the materials too fragile to use?

Collections use should be compatible with preservation objectives. If the object is so fragile that handling it will cause irreparable damage, provide the requestor with an image (photographic or digital) of the object, or a facsimile of the item, plus accompanying information. You should have a collection conservation survey done, and prioritize and address collections conservation and stabilization needs. Refer to Section G of this chapter. You also should have high quality photographs of the most used and fragile objects in the collection.

- Does the proposed borrower's facility meet NPS outgoing loan standards?

If the object will be used away from the museum collections storage, research room, work area, or from the park itself, you must generate an NPS outgoing loan agreement. The user (borrower) must meet all the conditions noted in the agreement. The user is responsible for treating collections carefully to maximize their future usefulness.

The borrowing institution must meet the standards outlined in the *Revised Standard Facility Report* published by the American Association of Museums. See Section G of this chapter and refer to *MH-II*, Chapter 5, Outgoing Loans, Section C, Documenting Loans, for additional information on the facilities report.

- Are there any legal restrictions on the item?

See *MH-III*, Chapter 2, Legal Issues.

3. *What NPS procedural guidelines cover using museum collections?*

NPS *MH-I* contains preservation and protection and *MH-II* contains documentation guidance to effectively use NPS museum collections. The *Conserve O Gram (COG)* series provides additional topical and timely information on preventive conservation for NPS museum collections.

- What NPS management policies and guidelines do I need to know?

Become familiar with the sections related to managing museum collections in the NPS policies and guidelines listed below.

- NPS Management Policies (1988)

This document contains policies that provide direction and set the parameters for management decisions in administrating the National Park Service. The following chapters deal with museum collections:

Chapter 4: Natural Resource Management, covering Natural Resource Collections

Chapter 5: Cultural Resource Management, Museum Objects and Library Materials, covering Treatment of Museum Objects; Acquisition, Management, and Disposition of Museum Objects; Historic Furnishings; Archives and Manuscripts; and Library Materials

- Director's Orders

Director's Orders outline the policies, instructions, and requirements imposed on the NPS at the Director's discretion. They don't restate policies and requirements imposed on the NPS by law, the President, the Secretary, or any other entity. The Director's Orders may, however, affirm that the NPS will comply with those policies and requirements.

- NPS Management Guidelines

NPS management guidelines outline the policies and procedures for many programs. The following pertinent NPS guidelines contain policies and procedures directly related to managing museum collections. They allow us to identify, preserve, protect, and document museum collections for present and future uses:

NPS Cultural Resource Management Guideline
(formerly NPS-28)

NPS Natural Resources Management Guideline
(formerly NPS-77)

NPS Personal Property Management Guideline
(formerly NPS-44)

NPS Records Management Guideline (in prep.)
(formerly NPS-19)

NPS Special Park Uses Guideline
(formerly NPS-53)

NPS Interpretation and Visitor Services Guideline
(formerly NPS-6)

You should be familiar with the *Departmental Manual* Part 411, Policies and Standards for Managing Museum Collections. This document outlines policies, responsibilities, actions, and standards for managing museum property in Department of the Interior bureaus. Refer to *MH-I*, Appendix A, Mandates and Standards, Section B, Departmental Policies and Standards for further information.

- Are the items entered into ANCS?

Make sure all museum collections that will be used have been accessioned and cataloged into the Automated National Catalog System (ANCS) prior to use. This includes objects loaned to off-site repositories. By entering information into ANCS and its successor, ANCS+, you readily can record and track information related to museum collection use.

- What are associated data and how may they be used?

Associated data refer to related information on a specific object or group of objects. Associated data include but are not limited to source of accession information, collection provenance or history (object provenience), and legal documentation of the collection. The catalog record contains extensive data categories that capture information on the object. Additional related data, such as annotations and research findings, are filed in the accession or catalog folder. Field notes, in particular, contain important and associated collection data.

These data are critical to the full understanding and appreciation of the object. Without these data, the research value of the object is diminished greatly. Know the various laws restricting access to museum collection data. Refer to *MH-III*, Chapter 2, Legal Issues, and to Question 4 below.

4. *What data do I need to restrict?*

MH-III, Chapter 2, Legal Issues, fully outlines the laws that deal with information on museum collections. Don't give out the following data:

- site location and the nature of archeological resources in accordance with the Archeological Resources Protection Act (ARPA) of 1979
- information protected by privacy and publicity law such as images or words of living private individuals (See *MH-III*, Chapter 2, Legal Issues.)
- location, character, and ownership information on historic resources, including cultural or religious sites, paleontological specimens, geological specimens, and culturally affiliated resources if the disclosure might invade privacy, impede the use of a traditional religious site by a practitioner, or endanger the historic resource according to the National Historic Preservation Act Amendment of 1980 (16 USC 470 w-3) (See *MH-III*, Chapter 2, Legal Issues, for guidance.)

Also restrict the following types of data:

- location information on nesting sites or other specific habitat information on threatened and endangered species consistent with the purpose of the Endangered Species Act (16 USC 1531 et seq.) and NPS Management Policies
- museum collection storage location and appraisal and insurance values, if the release may place collections at risk
- donor and lender addresses, the release of which may infringe on individuals' privacy

Names may be restricted to the fullest extent allowed by law if the donor or lender requests it. Place a notation in the accession folder, describing the donor or lender's privacy request at the time of the accession.

Such information may be considered releasable under the Freedom of Information Act (FOIA) on a case-by-case basis. If you receive a FOIA request, alert your superintendent and immediately contact and work with the FOIA officer to develop a response. Also talk to other affected NPS professionals such as the chief of resources (natural and cultural), Support Office (SO) curator and regional public relations officer. See Section F, Scientific Issues, and *MH-III*, Chapter 2, Legal Issues.

5. *What do I need to know about consumptive use?*

Consumptive use (destructive analysis or sampling) destroys or alters all or part of an object or specimen. It is an acceptable use of certain items in NPS museum collections. *Cultural Resource Management Guideline*, Chapter 9, Section 4, Consumptive Use of Collections states:

(c) Destructive analysis is a legitimate use of museum collections for approved research purposes when the impact is minor or when the object is common, in which case approval by the superintendent is required. If an object is rare or significant, a request for destructive analysis must be reviewed by the SO curator and approved by the regional director

Consumptive use of type specimens is not allowed.

Cultural Resource Management Guideline, Chapter 9, further states:

- (e) *The regional director will grant no exemption for use that might lead to loss or deterioration of museum objects that are directly connected with or prime survivors from the park's historic periods, events, or personalities; or are type specimens or one-of-a-kind natural history specimens; or are from systematic archeological collections, have known archeological site provenience, or have scientific value that has not been extracted and documented; or remain of scientific interest. The justification statement must certify that the objects requested for exemption do not meet the above criteria. If this certification cannot be provided, an exemption may be granted only by the director*
- (f) *No exemption will be granted for use of museum objects where such use may lead to loss or destruction of human remains, associated or unassociated funerary objects, sacred objects, or objects of cultural patrimony as defined by the Native American Graves Protection and Repatriation Act, unless such use is approved by the affiliated cultural group in addition to the regional director or director*
- (g) *An exemption may be granted for scientific analysis . . . of any museum object, except natural history type specimens, if that analysis is based on a professional research design that clearly documents the scientific need for the use of such techniques*

For specific information on how to obtain permission for consumptive use of collections, including threatened and endangered species, see *Cultural Resource Management Guideline*, Chapter 9, Section 4, Consumptive Use of Collections. The *Guideline* specifies that the regional archeologist or equivalent must be involved in the review of all proposals for destructive analysis of rare or significant archeological objects or materials. For additional information on threatened and endangered species, see Section F.

Many research uses involve destructive sampling. However, because of developing technologies that allow more powerful and non-invasive analysis, you should use caution when “using up” scarce objects or specimens for destructive analysis. The Guidelines for the Care of Natural History Collections published by the Society for the Preservation of Natural History Collections in *Collection Forum* 10, no. 1, p. 32-40 (1994) state:

Balance between use and preservation: *Associated with the responsibility of ongoing use and education use is obligation of the institution to maximize the value of each specimen for future use. This applies not only to the data associated with each specimen, but also to the physical and chemical integrity of the specimen. Thus, it is critical that the demands placed on natural history specimens for current research and education uses are balanced with the need for preservation of the specimens for future use.*

Consider the following criteria outlined in *Guidelines for Institutional Policies and Planning Natural History Collections* published by the Association of Systematics Collections, 1994, when you evaluate a written request to do destructive analysis:

- *The intended use must have scientific merit.*
- *The researcher must demonstrate competence with the proposed methods*
- *The proposed methods must be the least intrusive for obtaining the intended results, and must be likely to yield the intended results.*
- *The researcher must have sufficient resources to carry out the method.*
- *There must be sufficient material available to support the destructive sampling without sacrificing all the available material of the particular collecting event (lot or herbarium sheet)*
- *The researcher must be able to stipulate that (s)he has used all relevant specimens/objects available at the home institution first.*
- *The potential for compromising future utility of the specimen or object for other investigation should be minimized.*
- *The researcher should intend to disseminate results of the work within a reasonable amount of time.*
- *The researcher should be willing to abide by the institution's operational standards for processing and documentation.*
- *The researcher must indicate the quantity of material necessary for his/her research*
- *Failure of an individual to comply with institutional requirements and standards in previous transactions may be grounds for denying any new requests*

The researcher should:

- pay for all associated costs
- document the procedure used
- return all unused portions of objects or specimens unless otherwise agreed to in writing
- provide the park with a copy of the resulting analytical data and duplicates of tangible products such as slides within a stipulated time period

6. *What do I need to know about the chain of custody?*

Chain of custody is a legal term used when law enforcement issues or matters of evidence are at stake. Objects, specimens, archives, or personal papers that are collected or impounded for use in a court case as evidence may be subject to a chain of custody.

You must house these objects separately with tightly controlled security and limit access to authorized users. Everyone, including the curator and law enforcement officer(s), who views or handles the objects must log whenever these objects are accessed or used. As the person authorized to hold this material, you must be present whenever this material is viewed or handled by anyone. Nothing may be removed or rearranged. The chain of custody ensures that you can document everyone who had access to the evidence while it was in your custody. Your documentation must be able to withstand scrutiny in a court of law.

7. *What do I need to know about hazardous materials and chemical contamination?*

You should determine what parts of the collections may pose a problem; for example, mercury- or arsenic-treated specimens, radioactive minerals, asbestos-plaster mounts, or moldy, insect- or pest-contaminated records. Older collections especially are vulnerable and have a higher incidence of contamination from chemicals used to prepare, preserve, and protect specimens. Determine what problems may arise from materials used to treat or prepare collections historically, such as arsenic, mercuric chloride, DDT; vaporizing compounds with residues such as naphthalene or paradichlorobenzene; or wet collection fluids such as formaldehyde or alcohol. Review all collection documentation, annotation labels, and preparation notes to determine which chemicals were used to prepare collections. Research manuals and procedures that state past practices. Check the specimens for traces of chemical contamination.

Handling some objects and biological, geological, and paleontological specimens in the museum can present health risks. Be aware of potential hazards and, if appropriate, monitor for chemical agents.

If you suspect chemicals have been used, call in a specialist or test them yourself. Refer to *MH-I*, Chapter 11 and Appendix H, Curatorial Health and Safety, and the nine *Conserve O Grams* 2/1-9 on security, fire and curatorial safety. Record all chemicals used to prepare or treat specimens on the catalog record and the accession and catalog folders.

Inform users about objects that may have been treated or contaminated. If possible, have the object decontaminated when you receive a use request. Consult your park safety officer, a conservator, and the SO curator.

When NAGPRA items are repatriated, notify the recipients of any hazards associated with the items, such as arsenic or residual chemicals from fumigation.

8. *How do I establish and implement a park access and use policy?*
- Establish an access policy that covers the park purpose, times of operation, and general access procedures. Refer to *MH-I*, Figure G.5. Sample Park Museum Collection Access Policy and Procedures, for general museum collections, *MH-II*, Figure D.13, Access Policies and Rules Governing Use (Sample), for archival collections, and this chapter. You can adopt these sample policies as they are, or adapt them to your park's needs. The policy should be available to users of the collections. See Section C, Question 1, on establishing a working group to develop a park access and use policy.

D. Ethical Issues

1. *What ethical issues affect access and use of NPS museum collections?*
- Ethical issues affecting museum collections use include equal access for all researchers; civility and cooperation with colleagues and the general public; scholarly integrity; respect for confidential and private information; and a professional commitment to preservation.

In general, NPS staff must perform their responsibilities as described in the *Museum Handbook*, Parts I and II, Appendix A, Mandates and Standards; *MH-I*, Appendix D, Code of Ethics for Curators, Archivists, and Conservators; and in the ethical statements of the American Association of Museums (AAM), the American Association for State and Local History (AASLH), and the Society of American Archivists (SAA). The questions below further define appropriate conduct for NPS museum curators and archivists.

2. *What is equal access and how do I provide it?*
- Equal access is a fundamental principle. However, museum and archival and manuscript collections have two very different access and use traditions. See Section I, User Qualifications.
- ***For museum objects***, equal access means treating all researchers the same, whether they are NPS staff members or outside researchers. If you require an evaluation process before authorizing use of collections, you must apply this requirement to all individuals conducting personal research, including staff.

The International Council of Museums (ICOM) Code of Professional Ethics states:

It is the responsibility of the museum to use the collections for the creation and dissemination of new knowledge through research, educational work, permanent displays, temporary exhibitions and other special activities...the museum should seek to ensure that information in displays and exhibitions is honest and objective and does not perpetuate myths or stereotypes . . .

Members of the museum profession should deal with the public efficiently and courteously at all times and should in particular deal promptly with all correspondence and enquiries. Subject to the requirements of confidentiality in a particular case, they should share their expertise . . . allowing bona fide researchers properly controlled but, so far as possible, full access to any material or documentation in their care even when this is the subject of personal research or a special field of interest.

The AAM 1994 *Code of Ethics for Museums* states:

The museum ensures that . . . access to the collections and regulated information is [sic] permitted and regulated . . .

All policies and procedures (such as user evaluations) must be implemented equally for staff, visitors, and scholars. For a fuller view of how museum access and use policies have developed differently from archival access and use policies, see Section I, User Qualifications.

- ***For museum archival and manuscript collections***, equal access means providing access to all without review processes or credential evaluations. All taxpayers and visitors have a right to use federally held records and archival collections for research, according to FOIA and state Sunshine (state equivalent of FOIA) laws.

The American Library Association-Society of American Archivists' (ALA-SAA) *Joint Statement on Access to Original Research Materials, in Libraries, Archives, and Manuscript Repositories* states:

It is the responsibility of a library, archives, or manuscript repository to make available original research materials in its possession on equal terms of access . . . A repository should not deny access to materials to any person or persons, nor grant privileged or exclusive use of materials to any person or persons, nor conceal the existence of any body of material from any researcher, unless required to do so by law, donor, or purchase stipulation.

The American Historical Association (AHA) *Statement on Standards of Professional Conduct* states:

Since historians must have access to sources—archival and other—in order to produce reliable history, they have a professional obligation to preserve sources and advocate free, open, equal and nondiscriminatory access to them, and to avoid actions which might prejudice future access.

You need policies, procedures, appropriate forms, and staff training in monitoring access and providing reference services before granting access. If you are determining procedures and restrictions as the research occurs, you are failing to meet NPS standards.

If you don't have enough staff to handle walk-in researchers (all collections use must be continuously supervised), your access policies may require an appointment. Your policy may not state that only scholars or staff may use the materials, nor may you restrict permanently your archival and manuscript collections without a legal basis. Not having a reference staff is an unacceptable excuse for long-term restrictions. You must learn how to handle reference work or train staff to do it.

FOIA requests may require you to provide access to collections previously designated as restricted by the donor. These restrictions must be honored to the extent allowed by law. It's NPS policy not to accept restricted donations. See *MH-II*, Chapter 2, Accessioning, Figure 2. When such restrictions conflict with a FOIA request, consult with your FOIA officer, the NPS solicitor, and the SO curator.

Once federal archival and manuscript collections are made available to one, they are available to *all* (with the exception of materials exempted by law or preservation condition). See *MH-III*, Chapter 2, Legal Issues, for further guidance on FOIA and other legal issues. For a sample access policy and rules governing use, see *MH-II*, Appendix D, Museum Archives and Manuscript Collections, Figures D.13a-b.

- ***For equal access to both museum and archival collections***, establish clear and fair written policies and procedures. Apply your standard operating procedure for handling research and duplication requests equitably, whether the requests come by phone, fax, e-mail, or in person. Restrictions must apply equally to staff, visitors, students, scholars, and others. Staff are not allowed to research within restricted collections. Restrictions can be applied only to the extent allowed by law. For example, FOIA may legally require access to some materials that donors or staff have restricted for legal, ethical, or cultural reasons. Work with your superintendent, FOIA officer, and the NPS solicitor to resolve conflicts between restrictions and legal access requirements.

3. *What are ethical standards of civility and professional cooperation?*

Professional behavior forms a crucial part of this ethical responsibility for equitable access. The ICOM Code of Professional Ethics states,

Members of the museum profession have an obligation . . . to share their knowledge and experience with their colleagues and with scholars and students in relevant fields. They should show their appreciation and respect to those from whom they have learned and should present without thought of personal gain such advancements in techniques and experience that may be of benefit to others

- ***Courteous treatment of researchers:*** All researchers must be made welcome and treated courteously and equitably. NPS policy requires that museum staff serve the public in a professional and courteous manner, regardless of personal inclinations or other duties. NPS staff also are expected to work cooperatively with colleagues.

NPS collections are supported by taxpayer dollars; therefore, it is our responsibility to make these collections available to those for whom we hold them in trust. FOIA and state Sunshine laws provide external mechanisms for enforcing such access.

NPS should respond promptly to all reference requests for museum object and archival and manuscript collections, generally within 20 working days.

NPS researcher registration procedures provide an internal process for providing equal access. See *MH-II*, Appendix D, Museum Archives and Manuscript Collections, Sections T and U, for guidance.

- **Collegial Civility:** NPS staff also have a professional responsibility to:
 - treat their colleagues civilly and with consideration
 - respect diverse viewpoints
 - resolve disagreements without rancor
 - seek common ground for fruitful collaborations

The ICOM Code of Professional Ethics states:

Members of the profession form working relationships in the course of their duties with numerous other people, both professional and otherwise, within and outside the museum in which they are employed. They are expected to conduct these relationships with courtesy and fair-mindedness and to render their professional services to others efficiently and at a high standard.

When disagreements occur, as they do in all communities, both parties are responsible for working together to reach common ground. If personalities become an issue, return the focus to actual performance and behavior. Work together to resolve difficulties.

The American Historical Association (AHA) 1992 Statement on Standards of Professional Conduct states:

. . . the preeminent value of all intellectual communities is reasoned discourse—the continuous colloquy among historians of diverse points of view . . .

- **Professional Cooperative Responsibilities:** NPS museum staff are encouraged to work in partnership with other museums, libraries, archives, universities, and associations within their state and region to ensure the best preservation, protection, management, and access to NPS museum collections and data.

Staff are encouraged to develop cooperative preservation, descriptive, and access and use strategies to maximize resources and researcher access. For cooperative archival documentation strategies, refer to *MH-II*, Appendix D, Section Q, Questions 11-16. These strategies might include:

- cooperative development work to fund cataloging, preservation and use activities
- shared World Wide Web sites with area museums, archives, and libraries featuring online exhibitions, finding aids, virtual tours, and similar access systems
- cross-referenced and linked Web sites
- shared funding development campaigns with regional repositories, cooperating associations, the National Park Foundation, and other sources to enhance access
- shared published thematic catalogs or shared guides to multiple repository collections (union guides) in a region
- collaborative exhibits and exhibit catalogs using collections from several museums that can be sent to each museum involved
- collaborative research and analysis on collections in more than one museum

Forming partnerships with related organizations enhances the quantity and quality of work completed, giving the general public better access to collections. Additionally, sharing information on museum and archival procedures, techniques, and methods improves the professionalism of all involved. The NPS supports cooperative work with other federal, state, and local organizations and institutions to help meet preservation and access goals for parks and programs.

4. *What is scholarly integrity and what role does it play in providing access to collections?*

Scholarly integrity refers to the high standard of scholarly accuracy, balanced viewpoint, and lack of conflicts of interest that scholars are expected to achieve in their work. Scholarly integrity applies to NPS staff, including museum staff.

- ***NPS staff use of collections for personal research:*** You may use collections for personal research on your own time, as long as this research is:
 - supervised continuously by a professional
 - made known to your immediate supervisor
 - made known to other scholars using the same materials

You may not use restricted collections for *personal* research if those collections are not equally available to all researchers. However, you may use them for management purposes as needed. Avoid using NPS collections in a manner that may be judged a conflict of interest. Potential conflicts should be discussed with the NPS ethics officer.

- **NPS staff publications:** Staff should adhere to high standards of research, writing, editing, exhibitions, cultural consultation, and interpretation. Staff must:
 - be aware of changes in research resources, methodologies, and techniques by taking appropriate courses, learning from partners, reading widely, and consulting reviews of the published record
 - avoid factual inaccuracies by checking reputable sources carefully
 - avoid infringing copyright, privacy, and publicity laws and triggering lawsuits by obtaining necessary permissions and licenses
 - not plagiarize, but properly acknowledge others whose work has been used
 - keep informed of publications and exhibitions technologies and techniques in order to choose appropriate technologies for a message
 - conscientiously cite captions and credit lines as requested by creators and repositories holding original materials
 - avoid stereotypes and assumptions by reading widely both historical and current scholarship
 - obtain peer review from a range of qualified scholars and traditionally associated groups
- **NPS museum staff personal collecting:** See *MH-I*, Chapter 1, NPS Museums and Collections, Section F, 4b.2, Personal Collecting.
- **Avoidance of Conflicts of Interest:** NPS staff are expected to avoid situations that present a conflict of interest between their professional and private lives. See *MH-I*, Chapter 1, Section F, and *Ethics: An Employee Guide* (U.S. Department of the Interior, 1998). If you are uncertain if a situation poses a serious conflict, contact your supervisor, the NPS Ethics Officer, and your SO curator.

5. *How do privacy, confidentiality, and related restrictions affect my conduct?*

A variety of privacy and confidentiality issues affect how NPS staff grant access to and use of NPS collections, including those listed below:

- **Privacy of donor and lender negotiations:** Museums and archives have a professional responsibility to respect donors' and lenders' privacy by not divulging information on donor and lender negotiations or contacts. Honor this restriction to the fullest extent allowed by the law. This information might include:

- security arrangements of private or NPS collections
- quality and nature of materials brought into the museum for identification
- addresses of donors, lenders, or potential donors or lenders.

Note: Names may be restricted to the fullest extent allowed by law if the donor or lender requests it.

When uncertain of the extent of privacy protection, contact the NPS solicitor and your SO curator. The solicitor may determine that you can restrict this information based upon the National Historic Preservation Act Amendments of 1980. FOIA requests for donor negotiation information must be dealt with according to FOIA policy. See *MH-III*, Chapter 2, Section E, Question 1, and Section F, Question 11.

- ***Privacy of employee personnel, medical, and psychiatric records:*** Don't accession this material into the museum collection; it should be maintained in the park's records management system. If the records are official records, they belong in the National Archives not in the NPS museum collections. If they aren't official records, they are protected by privacy legislation during the lifetime of the individuals documented. See *MH-III*, Chapter 2, Section D, Question 4.
- ***Privacy of research:*** Both museum and archival researchers, whether NPS staff or outside users, must complete registration and duplication request forms according to NPS policy. See Section J, Documentation. These forms are required to:
 - maintain use documentation
 - help plan future acquisitions strategies
 - plan for publications
 - enhance replevin (legal return of illegally removed collections through the courts)
 - discourage theft
 - document parties who may be responsible for collections damage, vandalism, or theft

Although NPS staff collect and maintain these forms for administrative purposes, NPS curators and archivists support the privacy of researcher registration and duplication data to the extent allowed by law.

Treat researcher registration, circulation, and duplication data as if it were both privileged and private (restricted). In general, don't tell researchers:

- what topic other scholars or students are working on
- what is being used as research materials
- what is being duplicated

The only exceptions to this guidance are:

- When possible, notify researchers of similar research by other individuals using the same materials, to save both researchers from conflicts later. Obtain permission from both parties before such notification.
 - Once permission is obtained, parks may share this information for management purposes, such as for Government Performance Results Act (GPRA).
- ***Privacy and confidentiality issues relating to the collection's content:*** Both federal and state law protect the privacy of living, private individuals, while publicity laws in almost half of the states protect celebrities and their estates from unapproved commercial uses of their images. Other specific legislation described in *MH-III*, Chapter 2, protects location information for certain types of materials.

The ICOM Code of Professional Ethics states:

There is a special responsibility to respect the personal confidences contained in oral history or other personal material. Investigators using recording devices such as cameras or tape recorders or the techniques of oral interviewing should take special care to protect their data and persons investigated, photographed, or interviewed should have the right to remain anonymous if they so choose.

This right should be respected where it has been specifically promised. Where there is no clear understanding to the contrary, the primary responsibility of the investigator is to ensure that no information is revealed that might harm the informant or his or her community.

Museum staff and their families must not personally profit from, or publish data or information obtained, while working with restricted collections. Restricted access means no one, including staff, has access for personal research.

- ***Sensitivity to cultural issues:*** Cultural issues may pose powerful ethical challenges for many NPS museum staff. For guidance see Section E, Cultural Issues; *MH-III*, Chapter 2, Legal Issues; and *Cultural Resource Management Guideline*.

- **Donor and lender access and use restrictions:** While the expressed restrictions of collection donors and lenders don't override federal legislation, such as FOIA provisions or subpoenas (see *MH-III*, Chapter 2, Legal Issues), NPS staff should honor donor and lender restrictions to the fullest extent allowed by law. See *MH-II*, Chapter 2, Accessions. It may be necessary to talk with the NPS solicitor on how to best meet donor and lender requirements without conflicting with equal access or FOIA provisions.

6. *What role should preservation play in NPS ethical values?*

The ICOM Code of Professional Ethics states:

Subject to the primary duty of the museum to preserve unimpaired for the future the significant material that comprises the museum collections, it is the responsibility of the museum to use the collections for the creation and dissemination of new knowledge . . .

- **Preservation of the museum collections:** Use of collections should not cause significant and irreversible damage to the collections. The exception is destructive analysis, which is a legitimate use of museum collections for approved research purposes when the effect is minor or the object is common. See *Cultural Resource Management Guideline*, Chapter 9, Management of Museum Objects. While all exposure to light, handling, and duplication causes some damage, this is a natural part of the inevitable self-destruction of all organic materials. NPS staff will attempt to mitigate this damage to the greatest extent by following the guidance in *MH-I*, and in Section G, Preservation and Protection Issues, below.
- **Preservation of the informational context of museum objects:** Much of an object's value resides in the information we have about it, including its creator, collector, provenance or history, provenience, cultural and historical context, and topical identifiers, such as:
 - collection provenience for archeology
 - phylum, class, order, family, genus, and species for biological, and paleontological specimens
 - artist, style, medium, technique, iconography, and period for art or historical works
 - creator, dates, provenance, physical description, subject matter, arrangement, restrictions, and historical background for an archival or manuscript collection

It is equally essential, for legal reasons, to document any:

- special permissions or authorizations for use
- releases (model releases or interviewee releases)
- site licenses

These legal authorizations allow copyright or privacy and publicity-protected materials to be used in publications, exhibitions, and other special uses, including the Internet, such as the World Wide Web. You are responsible for accurately maintaining this information and documentation.

Take care to accurately and sensitively reflect the object or document creator's perspective and the cultural context without the addition of errors or unsubstantiated personal opinions.

Museum staff must be:

- eager to serve their audiences with useful and accurate materials
- able to safeguard the accuracy and currency of the data they have on museum collections
- knowledgeable about how to conduct research in a professional manner
- willing to share their work for peer and associated community review and commentary prior to publication
- able to accept editing, fact-checking, and correction
- willing to share their sources, data, and evidence in case of a challenge to the publication or exhibition text
- responsible for monitoring to ensure the object's cultural context is accurately and sensitively reflected in products of researchers, in NPS publications and in other uses of the collections

When researching and interpreting museum materials during cataloging, exhibitions, publications, and reference work, avoid inserting stereotypes, assumptions, and unsubstantiated personal opinions into the accessioning, cataloging, description, and reference. All personal opinions and observations should be identified and documented as such.

Museum staff are responsible for enhancing this contextual information through accurate and scholarly research that follows the best practices of the profession. Every attempt should be made to capture substantiated expert knowledge held by donors, scholars, and associated groups for the museum documentation, particularly the catalog record and archival finding aids. Research of NPS museum collections must not endanger this informational context.

Databases, finding aids and other descriptive systems (including automated systems) must be designed and managed to make it impossible for researchers to change data or to access legally restricted data, such as archeological site location information. See *MH-III*, Chapter 2, Legal Issues.

Responsibilities of Museum Staff	
To whom are you responsible?	What must you do?
The General Public	<ul style="list-style-type: none"> • Provide equal access to all non-restricted collections to the extent allowed by law and consistent with NPS policy. • Protect private and confidential information to the fullest extent allowed by law. • Ensure the security of the museum collection. <ul style="list-style-type: none"> – Don't provide access to unaccessioned and uncataloged collections. – Don't provide access without supervision. – Don't provide access to originals of high-value or fragile materials. – Deny access to collections to researchers who have been known to steal from or damage collections. • Preserve integrity, accuracy, and completeness of the information context (documentation) of museum objects. • Preserve the museum collection physically. <ul style="list-style-type: none"> – Teach researchers how to handle items. – Provide photographs or duplicates for research when materials are fragile. – Maintain proper surveillance of researchers. – Ensure the research room environment doesn't endanger items. • Record expert knowledge of donors, scholars, and associated groups and add it to the museum documentation as appropriate.
Your Employer (the NPS) Your Employer (cont.)	<ul style="list-style-type: none"> • Avoid all conflicts of interest and appearance of such, in the subject area of the collections including: <ul style="list-style-type: none"> – personal research in restricted collections – personal publication or distribution of restricted information – competitive employment or businesses – appraisal of objects outside NPS – receipt of personal gifts – development or research on personal collections – removal of research materials and documentation created during the scope of employment • Follow the letter and the spirit of NPS and DOI policies and procedures. • Work in a fully professional fashion following the guidelines provided by professional associations (AAM, SAA, and AASLH).
Yourself and Other Employees	<ul style="list-style-type: none"> • Ensure your staff knows and uses NPS museum management ethics policy and legal guidelines. See <i>MH-III</i>, Chapter 2, Legal Issues, and <i>MH-I</i>, Appendix D, Code of Ethics for Curators, Archivists, and Conservators. • Monitor staff compliance. • Ensure staff use of museum collections is equitable, made known to supervisors and other scholars using the same material. • Determine that NPS staff don't conduct personal research in restricted collections, or publish or distribute restricted information. Staff must not get privileged access.

Responsibilities of Museum Staff	
To whom are you responsible?	What must you do?
	<ul style="list-style-type: none"> • Ensure NPS staff are informed they can't become dealers or receive gifts from dealers.
Our Donors and Lenders	<ul style="list-style-type: none"> • Ensure the privacy of donor and lender negotiation information to the extent allowed by law, unless or until written permission is received to share this information. • Follow existing access and use restrictions to the fullest extent allowed by law. • Capture the donor's knowledge about the donated materials. • Obtain from the donor all copyrights, model and interview release forms, and related permissions so that NPS can use the collection fully.
Creators and Their Heirs	<ul style="list-style-type: none"> • Obtain from all creators or their heirs all copyrights, model and interview release forms, and related permissions so that NPS can fully use the collections. • Give full credit to the creator in all credit lines and citations. • Respect creator restrictions to the fullest extent allowed by law.
<p>Those peoples and groups whose collections NPS holds, or who appear as subject matter of NPS collections</p> <ul style="list-style-type: none"> – Affected groups – Ethnic groups – Native Americans – Native Hawaiians <p>Peoples and Groups (cont)</p> <ul style="list-style-type: none"> – Private individuals – Religious groups 	<ul style="list-style-type: none"> • Follow legal and policy guidelines on access and use. • Ensure collections are treated with respect and empathy for associated groups. • Investigate and document potential collection sensitivity issues when collections are acquired and <i>before</i> providing access. • Be aware of laws that affect access to these materials. See <i>MH-III</i>, Chapter 2, Legal Issues. • Consult with the associated groups <i>before</i> making decisions that may affect the group, such as acquisition of or access to sacred or otherwise sensitive materials. • Provide access to federal records as required by NPS policy and state and federal laws.
<p>Your Users</p> <ul style="list-style-type: none"> – Collaborators – News reporters – Park staff – Publishers – The public – Scholars – Students – Writers 	<ul style="list-style-type: none"> • Provide equal access to all, regardless of whether they are staff, students, scholars, reporters, or public visitors. • Keep researcher registration and duplication data confidential to the fullest extent allowed by law. Only share this data with the researcher's permission. • Provide courteous, knowledgeable, and accurate reference service. • Maintain user documentation including copyright and privacy statements, researcher registration, and duplication forms. • Thoroughly document and maintain files on any permissions given or received to publish or use materials (including site licenses, publication permissions, copyright receipts) for exhibits, Internet sites, and publications.

Responsibilities of Museum Staff	
To whom are you responsible?	What must you do?
<p>Your Professional Colleagues</p> <ul style="list-style-type: none"> - Archeologists - Architects - Archivists - Biologists - Conservators - Curators - Geologists - Historians - Landscape Architects - Librarians - Paleontologists - Registrars 	<ul style="list-style-type: none"> • Follow the professional ethics statements of archivists, curators, registrars, and related disciplines. • Provide to all high-quality reference and access service to collection records, consistent with NPS policy and state and federal laws. • Work with cooperative or collaborative partners, such as other museums, archives, educational programs, and libraries to: <ul style="list-style-type: none"> - create shared Web sites - publish union guides - develop travelling exhibitions and catalogs • Share information on NPS-developed access and use strategies at professional meetings

7. *What do I need to know about employee ethics?*

As a federal employee, you are expected to maintain high standards of honesty, integrity, impartiality, and conduct. These standards ensure the proper performance of government business and the continuing confidence of the people of the United States. As a federal employee, you're expected to serve the public responsibly and maintain the public trust. See *MH-I*, Chapter 1.

If you are offered monies for a work created during your normal scope of work as a NPS employee, consult your park Ethics Officer to determine if the park may transfer the money to the cooperating association or

equivalent approved donation accounts for use by the park. You must not personally accept a check or other payment for work completed on NPS time.

8. *What do I need to know about professional ethics?*

Most professional organizations publish ethics statements. See the Codes of Ethics for professions related to museum work in *MH-I*, Appendix D.

E. Cultural Issues

This section addresses some of the cultural concerns that affect use of cultural and natural collections. You should identify the associated groups that have an interest in the park collections, how they were made, created, and are stored, used, or made accessible. Work with the associated groups to identify their concerns and to honor those concerns to the fullest extent allowed under the law and NPS policies. Many groups have valid concerns about how their cultural heritage material is used. You need to understand and deal sensitively with these issues. Management Policies (5:10) states that interested persons will be permitted to inspect and study NPS museum objects and records in accordance with standards for preservation and use of collections and subject to the policies regarding confidentiality of resource data.

Where possible, consult with the associated groups before acquiring potentially sensitive museum collections. Keep in mind that access to NPS museum collections means balancing the interests of many traditionally associated groups—including makers, creators, scholars, and subjects—and those yet to come, whether of the culture represented or outside it. Consult with the SO curator, discipline specialists, your park FOIA officer, the NPS solicitor, and the NPS Ethics Office staff as necessary.

1. *What cultural concerns affect use?*

The western notion of intellectual property, copyright, and privacy is being widely discussed. Certain groups have proposed that indigenous peoples have special and collective rights to all aspects of their culture, whether expressed tangibly or not. Such an approach would protect ideas as well as recorded, filmed, painted, sculpted, choreographed, and written expressions of ideas. These proposals run counter to U.S. copyright legislation, which protects only tangible expressions for a limited time.

You should be aware of this debate, but remember you are obliged to follow the law (see *MH-III*, Chapter 2, Legal Issues), implement NPS policies and procedures, and act in accordance with professional standards and ethics. The concerns of some indigenous cultures need to be balanced against the:

- First Amendment rights to freedom of speech, allowing American citizens to write and speak about anything not expressly forbidden by law
- FOIA and related state Sunshine laws, which make information held by public institutions available to the public, unless a particular statutory restriction prohibits access
- lack of a mechanism for limiting access retroactively to information. Once information has been available to one researcher, FOIA requires that other researchers wishing to use the material in federal repositories have equal access
- existing copyright and privacy laws

2. *How do I identify the concerned parties?*

Work with your park or regional ethnographer to determine who the traditionally associated groups (the groups that may be affected by the use of the object) are by identifying the:

- creator of the object(s)
 - artist
 - collector
 - craftsperson
 - photographer
 - researcher
 - writer
- heirs and descendants of the original creator (who may still hold intellectual property rights, such as copyrights)
- donor(s)
 - may be the same or different from the creator or the creator's heirs
 - a collector who purchased or traded for object(s)
- descendants of the donor or former owners
 - may still hold some intellectual property rights, such as copyrights
- communities; tribes; social, ethnic, and occupational groups, whose identity is connected to the:
 - objects(s)
 - symbol(s) on the objects
 - non-symbolic representation(s) on the objects
 - associated rituals
 - associated stories or other legacy information
- archeologists, ethnographers, and others who may have excavated, collected, researched, or worked with the materials
- the general public as taxpayers, researchers, and potential users

An item may be associated with more than one group. Each associated group may have a set of cultural rules and meanings, each of which should be taken into consideration where possible.

3. *How does NAGPRA affect collections access and use?*

In accordance with the Native American Graves Protection and Repatriation Act (NAGPRA) of 1990 (25 USC 3001-3013), NPS is required to consult with all associated or affiliated tribes and lineal descendants regarding the treatment and potential repatriation of those NPS museum collections defined as NAGPRA-eligible. Refer to *Cultural Resource Management Guideline, Appendix R, NAGPRA Compliance* and *MH-II*, Chapter 6, Deaccessioning, for additional information. Consult your SO curator concerning storage and handling procedures of NAGPRA-eligible collections.

NAGPRA doesn't provide a legal basis to restrict access and use of NAGPRA-eligible museum collections documentation or archives. NAGPRA doesn't call for the repatriation of archival and manuscript materials. Documentation of objects being repatriated via NAGPRA may be obtained by FOIA requests, even though the records may be sensitive. Traditionally associated groups should be informed that sensitive NAGPRA documentation cannot be withheld if a FOIA request for it is received. If you receive a FOIA request for NAGPRA documentation, consult with your superintendent, FOIA officer, NPS solicitor and SO curator as explained in *MH-III*, Chapter 2, Legal Issues.

Consider the effect on the traditionally associated groups if the information you collect and maintain is publicly available. You can't change the legal requirement to make information publicly accessible, but you can control what you collect. Collect and keep only the information necessary for managing NPS museum collections.

You may later need to justify your actions, such as deaccessioning, through appropriate documentation. If you have not collected adequate documentation or disposed of the documentation, you may be in a difficult situation. You can avoid this problem by providing more generic information without potentially problematic specifics. For example, you may be able to state, "this ceremonial rattle relates to Spring ceremonies," as opposed to "this XXXX rattle is held by the YYYY priest, who does the following six things with it to induce corn fertility in the Spring."

4. *How does the Executive Order 13007—Indian Sacred Sites affect access and use?*

The NPS management guidelines for carrying out the Executive Order are being drafted and will be distributed when finalized.

5. *What are the traditionally associated groups' concerns about access and use?*

Traditionally associated groups may be concerned about a collection item or the knowledge associated with it. This includes:

- what the item represents to cultural insiders
- information on object use

- documentation of ritual observations or associated stories

Potential concerns may arise with:

- ***Use by the museum in:***
 - exhibitions
 - conservation treatments
 - collections management handling
 - research
 - publications (including text, Internet, sound records, and moving and still images)
- ***Use by the general public when:***
 - photographing
 - interpreting
 - viewing
 - researching
 - handling
- ***Ceremonial use by the associated communities in:***
 - ceremonies in the museum
 - off-site ceremonies and ritual observances

There may be culturally defined rules for transmitting and controlling knowledge about the collection, which may involve rituals or prohibitions. See *MH-III*, Chapter 2.

Inform traditionally associated groups that NPS-held archives, manuscripts, and collections documentation are subject to FOIA.

As manager of the park collections, you must strike a balance among the rights of the:

- creator and the creator's heirs (may have the copyrights)
- potential users
- taxpayers who fund use of collections

- park to have accurate and complete collection management information
- individuals and groups documented

6. *What limitations may apply to access and use?*

Collections information may have the following legal restrictions. See *MH-III*, Chapter 2 for specific guidance.

- ***Federal and state privacy and publicity law*** restrictions may apply to the words, images, and persona of living private individuals and celebrities (whether dead or alive), including photographs, family letters, oral and video history interviews and transcripts, and similar materials.
- ***Copyright*** restrictions may apply to the words and works of individuals depending upon when they were created, and if and when they have been published.
- ***Archeological Resources Protection Act*** restrictions apply to location information on archeological excavations. You must **not** grant access to the location of archeological sites, potential sites, or shipwrecks in records, databases, or any format, even if the request is a FOIA request.
- ***National Historic Preservation Act*** restrictions may protect the disclosure of information that can create a substantial risk of harm, theft, or destruction of historic resources, as well as preventing disclosures that invade privacy or impede the use of traditional religious sites by practitioners.

Once made accessible to one researcher, archival and manuscript materials are available to all under the principle of equal access.

7. *What are some factors in determining access to and use of cultural materials?*

Different groups may have different rules about how acceptable access and use procedures are determined. These include:

- ***Gender:*** some materials are not available to women or to men
- ***Age:*** some materials are available only to tribal elders as keepers of traditional knowledge
- ***Social and occupational role:*** a person's occupation or membership in particular groups may prohibit using an object
- ***Group membership:*** a group may request access or information be restricted to a particular group
- ***Cultural prohibitions on information:*** for example, viewing or photographing powerful objects may be prohibited

This is one area where traditionally associated group concerns and NPS policies may be in opposition. Remember, you provide equal access to NPS museum collections, unless restricted by law or in accordance with NPS policy. Work with traditionally associated groups to share federal laws and NPS mandates, policies, and procedures, and to develop acceptable strategies. It may be possible to provide:

- *Access during certain periods or only in certain spaces*
- *Access via a copy*
- *Access with notification*

Allow the affiliated group to leave a statement with the museum explaining why the information is sensitive and should not be published. Researchers requesting the item may be asked to read the statement before access is granted.

If both parties are willing, arrange a meeting between the researcher and the traditionally associated groups to address concerns. Speak to your SO curator, discipline specialists, NPS solicitor, and FOIA officer for guidance.

8. *How does the use context affect cultural concerns about access and use?*

Some potential concerns include:

- **Location:** allowing access to a room where a negative event occurred can be a source of power or danger according to some cultures; a location may have negative or positive connotations
- **Temporality:** allowing researchers or staff to use material at a certain time of day or during a particular season may be problematic according to some cultures; the group may want certain uses restricted by date or time
- **Object orientation:** placing an object so that it faces a particular direction in an exhibit or for research may be problematic in some cultures
- **Cultural context:** allowing access by a researcher from a different group, may be a cause for concern; associated groups may object to exhibiting or loaning collections to rival groups
- **Proximity to other objects:** storing sacred objects of a particular group in a room that also has human remains or funerary objects may be problematic for some cultures

The associated group may request that certain ritual considerations be followed before or after use of a collection, such as the blessing of space or a cleansing ceremony. However, potential contamination issues can occur from some ceremonial or ritual activities (for example, if cornmeal is used, it may provide habitat for insects). Work with the group to ensure they understand the reasons for NPS policies and procedures. Make alternative arrangements, where possible, to accommodate these concerns.

9. *What cultural issues may arise when the general public uses a collection?*

When a member of the general public uses a collection, traditionally associated groups may request that public and researcher use be supervised by their representative in addition to NPS staff supervision. A member of the traditionally associated group could accompany the supervisor as an observer, if management so chooses, but only NPS staff should provide supervision. Alternatively, the manager may permit a qualified member of a traditionally associated group *who is a NPS employee or volunteer* to supervise. Another option is for the concerned associated group to leave a statement of concerns to be provided to researchers when the collection is used.

The NPS follows the principle of equal access. The researcher has the right to unobstructed access. Instead of installing a secondary observer, such as a member of the traditionally associated group, which may have a chilling affect on research, work with the traditionally associated groups to identify problematic material and develop access strategies that meet both NPS and the traditionally associated groups' goals. The agreed-upon access and use policies for these materials will be honored to the fullest extent allowed by law.

Work with traditionally associated groups to establish access procedures for sensitive cultural object(s) before providing access.

Traditionally associated groups may also request that the NPS restrict a type of use. For example, the associated community may indicate that viewing, but not touching, an object is acceptable or that some objects or information should be excluded from public or ceremonial use. Share the concerns of the aggregated group with the person(s) requesting access. Append a statement of concerns if one is provided. Anyone can use NPS collections if the use conforms to NPS policies and procedures.

10. *What concerns affect how traditionally associated groups use museum collections?*

The following issues may affect how traditionally associated groups use a museum object:

- ***Restricted use due to contested or shared affiliation:*** When an object is affiliated with several groups or when affiliation is contested, one group may ask that another be excluded from consultations and using the collection. Inform individuals requesting restrictions this is counter to NPS policy.
- ***Special use:*** Associated groups may request use of the collection for ceremonial activities, not all of which contribute to preserving the object. For example, the use may result in contaminates from blessing or cleansing rituals or body paint on textiles.

Special uses must be judged equitably by the:

- effect of the use on the object
- applicable legal restrictions on access
- donor and lender restrictions on access
- **Off-site use:** A use request may be for an off-site ceremony because the location of the event may be critical to its success. All uses, including off-site uses, must follow NPS policies and procedures, such as preparing an outgoing loan agreement. Each off-site use request is considered individually. You should have a NPS employee present to supervise the uses that are not traditional museum uses.
- **On-site but unsupervised use:** An associated group may want to perform a ritual unsupervised by NPS, which is against NPS procedures. If a member of the associated community is a NPS employee or volunteer, then that person could provide the supervision.

The following may affect how traditionally associated groups use collection data:

- **Research and publication:** If one group researches and publishes the subject document(s) or archival materials, it has opened the door for authorization of all future research and publication requests, regardless of source, under FOIA and equal access.

Major research projects into a specific group's history, culture, or material culture initiated by NPS staff or an outsider should be undertaken in consultation with the traditionally associated groups where possible. There may be cultural concerns about who does the research, how the research is conducted, how the group will be represented in the study, and the distribution of the study. See *Cultural Resource Management Guideline* for guidance.

11. *What cultural concerns affect the use of natural history collections?*

Most cultural concerns affecting use of natural history collections mirror the concerns discussed above. Specific issues for natural history collections include:

- **Use and value:** The specimen may have multiple uses and values for one community, such as the yucca that has subsistence and ceremonial uses. These uses and values may be related to the traditionally associated groups' subsistence needs, or may be religious or ceremonial in nature. Refer to *Cultural Resource Management Guideline*, Chapter 10, Management of Ethnographic Resources.
- **Meanings:** The specimen(s) can have multiple meanings for different groups; for example, a bear skull can represent subsistence activities of one community, while it has ritual significance for another.

Associated groups may request that NPS restrict access to or use of certain information. This information may violate the parameters governing transmission of knowledge within a particular culture, for example:

- ***Ceremonial or medicinal access concerns:*** Groups may request that NPS restrict access to information on the ceremonial or medicinal uses of certain plants. For example, the medicinal qualities of a plant may be limited to all but a healer or midwife within the requesting culture.
- ***Plant locations:*** Groups may request that NPS restrict subsistence plant locations, especially for plants that gain power from a particular location.

Provide equal access to NPS collections with a few uniformly applied legal exceptions. According to the ethics policies of AAM and ICOM, and FOIA (for archives and museum documentation), if materials are available to one group they must be equally accessible to all. See Section D, Ethical Issues, Question 2.

12. *What other concerns may the traditionally associated groups have?*

Traditionally associated groups may be concerned about:

- scientific testing
- extensive handling
- reformatting or copying

Explain to the associated group, as you do to all users of NPS collections, how NPS staff care for collections. Share NPS guidance with the group. Consider inviting a member of the associated group to attend NPS collections management training. Where reasonable, legal, and ethical, follow the wishes of the associated group.

13. *When must I be sensitive to the concerns of traditionally associated groups?*

Always. Work with traditionally associated groups when developing procedures for using museum collections. Respectfully listen, understand, and honor concerns if they are legally, ethically, and reasonably possible under NPS policy and procedures. You should consult with the traditionally associated groups ***before*** access is provided.

If the object, associated knowledge, use, or rituals have religious connotations or cultural restrictions, involve the associated group, where possible, in developing procedures to use and care for the object.

14. *What do I do if I can't grant a traditionally associated group's request?*

If traditionally associated groups have made special requests for restricting or approving access or use of museum collections, it is important to work with them, even if their request can't be granted. Explain to them what NPS policies and federal and state laws dictate for access to NPS museum collections. Consult with your SO curator and ethnographer prior to meeting with the group to determine how best to ensure your message will be understood.

The group you are working with may have culturally defined roles and a specific context for transmitting knowledge on the associated materials. Some groups won't object to NPS doing research for management purposes, but they may want the data kept confidential. Because we can't guarantee confidentiality due to FOIA and state Sunshine laws, it is important to inform the groups of these legal constraints. In other cases, the group may request research, especially if its members are concerned that traditional knowledge is dying and they see NPS as a repository for their knowledge.

15. *What religious concerns must I consider?*

Cultural issues that affect use of religious item(s), include those discussed in Questions 1, 8, and 10. Identify the associated groups and religious concerns related to the collection. Sacred objects often require culturally specific procedures for care and use. Cultural rules governing the handling and use of an item may vary. See *NPS Management Policies* and *Cultural Resource Management Guideline*. *NPS Management Policies, Chapter 5:11, Ethnographic Resources*, requires that:

Certain contemporary Native American and other communities are permitted by law, regulation or policy to pursue customary religious . . . and other cultural uses of park resources with which they are traditionally associated

NPS Management Policies, Chapter 8:9, Native American Use, states that in keeping with the spirit of the American Religious Freedom Act (42 USC 1996),

The NPS will be as unrestrictive as possible in permitting Native American access to and use of traditional sacred resources for customary ceremonials.

and continues,

. . . requests to conduct Native American activities will be subject to the same criteria as other special park uses unless the activity is specifically authorized by federal statute or treaty right.

Management Policies also states that the NPS will ensure the following:

. . . access to and use of natural and cultural resources in parks will be applied in an informed and balanced manner that is consistent with park purposes and does not unreasonably interfere with Native American use of . . . sacred resources and does not result in the degradation of park resources (8:9).

Traditionally associated group(s) may request restrictions on access or use of information about the collection to cultural insiders or specific community members. The traditionally associated groups may:

- request specific procedures to protect the sacredness of the item, or to protect the people who come into contact with the item (See discussion in Question 1.)

- have cultural prohibitions on handling or viewing objects connected with a burial
- want to desanctify sacred objects in NPS custody, eliminating potential religious issues

Follow NPS policies and procedures, and legal guidelines for culturally sensitive collections, just as you do for all collections. Consult with your SO curator, FOIA officer, and the NPS solicitor if you have questions.

F. Scientific Issues

1. *What is a natural history type specimen?*

A type specimen is the actual specimen or series of specimens used to describe a taxonomic species or subspecies. It functions as the "name-bearer" of the species designated in the description of a species. Type specimens are the bearers of the scientific names for all taxa. There are several categories of type specimens, such as, holotype, isotype, paratype, and topotype. Refer to the *MH-II*, Appendix H, Natural History, for additional information on type specimens.

2. *What do I need to know about the use of type specimens?*

Type specimens are critically important to the scientific community and researchers because they are the international reference standards that provide objectivity in scientific nomenclature. It is an internationally accepted practice that all types are to be held in trust for science by those responsible for their safekeeping. In particular, type specimens are important to management of park natural resources.

Make every effort to ensure these specimens are readily available for present and future research, and for new and developing non-invasive analytical technologies by:

- maintaining them in good condition in a stable environment
- housing them in separate and secure housing within the museum storage area
- closely monitoring and controlling their access and use.

All requests to use a type specimen or series and associated collection data should be in writing. Students should include letters of recommendation from their advisors. The letters should include the type specimen(s) to be examined, and the nature of the use. Researchers should be able to demonstrate they are qualified to conduct the research, and that the particular type specimen(s) requested are critical to their research project. Consumptive use of type specimens is not allowed. See Section C, Question 5 above, for information on consumptive use of specimens.

Type specimens, in particular holotypes, should not be loaned from the collection unless they are on loan to a repository for management and storage purposes where they may be made available for research purposes.

Consult with the SO curator and specific systematic discipline specialists if you receive a request to borrow a type specimen.

3. *What are voucher specimens?*

The voucher specimen is proof, as a single specimen or series of specimens, of the existence of a species at a particular time and place. The presence of a voucher supports the tracking of habitat and geographic expansion of a species, or the presence or absence of a species following changes in its habitat.

The *Guidelines for Institutional Policies and Planning Natural History Collections* published by the Association of Systematics Collections (ASC), 1994, states that the voucher is a:

. . . specimen and its associated data that physically document the existence of that organism or object at a given place and time.

The *Guidelines for Acquisition and Management of Biological Specimens*, edited by Welton Lee et al, published by ASC, 1982, notes the following:

Voucher specimens ensure that the identification of organisms studied can be verified . . . They are the sole means to verify the data documented in a report . . . and to make historical comparison possible . . . they provide critical information . . . for future investigations . . .

4. *What do I need to know about the use of voucher specimens?*

Because of their importance in validating a study, voucher specimens must be documented thoroughly with field and other relevant reports. They must be maintained in good condition and be accessible to researchers.

Requests to use voucher specimens should be in writing. Refer to Question 2 above for what should be included in the request.

Because voucher specimens validate a study, don't allow consumptive use. In rare cases, consumptive use of voucher specimens is possible with approved justification. Consult with the SO curator and specific systematic discipline specialists if you get a consumptive use request. You may lend voucher specimens.

5. *What do I need to know about the use of threatened and endangered species?*

Be familiar with NPS responsibilities in the management of endangered, threatened, and rare species, and candidate and sensitive species. Refer to *Natural Resources Management Guideline*, Chapter 2, Endangered, Threatened, and Rare Species Management. NPS museum collections include threatened and endangered (T&E) species and candidate species. Requests to use T&E species should be in writing. Consumptive use of T&E is possible with a written justification. Refer to *Cultural Resource Management Guideline*, Chapter 9, Management of Museum Objects, Consumptive Use of Museum Objects.

You may lend T&E species. You don't need a permit to loan threatened or endangered species within the United States if they were taken lawfully and "if there is no barter, credit, other form of compensation, or intent to profit or gain . . ." *Fish & Wildlife Facts*, U.S. Department of the Interior, Fish and Wildlife Service (FWS). However, you must get an export permit from the FWS for loaning T&E specimens outside the U.S. The export permit covers the Endangered Species Act as well as the Convention on International Trade in Endangered Species of Wild Fauna and Flora (CITES). Under these regulations, the U.S. established procedures to regulate the import and export of the species covered by the treaty. FWS, Office of Management Authority acts as the U.S. Management Authority for CITES. You'll also need to get an import permit to cover the loan return. You can get the permit from:

Fish and Wildlife Service
Office of Management Authority
4401 North Fairfax Drive
Room 430
Arlington, VA 22203
Tel: (800) 358-2104

For additional information, see the following FWS booklets, also available from the above address:

CITES, Appendices I, II, and III, to the Convention on International Trade in Endangered Species of Wild Flora and Fauna. August 12, 1996.

Endangered and Threatened Wildlife and Plants. 50 CFR 17.11 and 17.12. October 31, 1996.

6. *What do I need to know about access to information about threatened and endangered species?*

Location information on nesting sites or other specific habitat information on threatened and endangered species is extremely sensitive. Consistent with the purpose of the Endangered Species Act (16 USC 1531 et seq.), the NPS

. . . will promote the conservation of all federally listed threatened, endangered, or candidate species within park boundaries and their critical habitats. As necessary, the Park Service will control visitor access to and use of critical habitats, and it may close such areas to entry for other than official purposes . . .

Management Policies, Chapter 4, Natural Resource Management, Threatened or Endangered Plants and Animals.

In accordance with NPS Management Policies, you should control carefully access to this information. You should make these data available only in response to a written FOIA request. If you get such a request,

immediately contact your FOIA officer, chief of Natural Resources, SO curator, and solicitor. For further information, see *MH-III*, Chapter 2, Legal Issues.

G. Preservation and Protection Issues

1. *How do I balance preservation and use?*

Both preservation and use are fundamental to a successful museum program. Collections are maintained because of their value to the park, the NPS programs, and the general public, who provides the funding. If your museum focuses on preservation to the exclusion of collection access and use, you are not meeting NPS or museum standards.

Neither preservation nor use are absolute values. One should not be given preference over the other. If you make informed decisions based on NPS policies and procedures, you will effectively manage and balance both preservation and use without significant compromises.

2. *How do I preserve collections?*

- ***Material stabilization***

Museum materials deteriorate over time. The goal of a balanced preservation and use program is to minimize collection deterioration, while maximizing access. Deterioration can be slowed greatly through the following actions.

- Use proper storage and housing techniques and materials. See *MH-I*, Chapter 7, Museum Collections Storage.
- Conduct collection condition surveys of materials and implement restricted handling procedures when recommended. See *MH-I*, Chapter 3, Museum Objects Preservation.
- Provide treatment when necessary (for example, mending tears or rips in paper documents). See *MH-I*, Chapter 8, Museum Object Conservation Treatment.

- ***Proper handling***

- Train staff and researchers how and why to handle all the types of objects and materials in the collection. See *MH-I*, Chapter 6, Handling, Packing, and Shipping Museum Objects.
- Monitor all use for improper handling techniques, theft, or vandalism. See *MH-I*, Chapter 6, and *MH-II*, Appendix D, Museum Archives and Manuscript Collections.
- Provide copies, duplicates, facsimiles, record photographs, or reproductions for research when an item is fragile, of high value, or vulnerable to damage, alteration, or theft.

- Document the collections to establish and maintain accountability and to monitor and track preventive maintenance.
 - Keep proper records, such as researcher registration, copyright and privacy statements, and duplication forms, to track use of an object or a collection and any theft or vandalism.
 - Encourage users to make initial surveys of holdings using images and documentation, rather than original objects, as they narrow the focus of their research.
- ***Proper storage environment***
 - Monitor and control temperature, relative humidity (RH), and light levels. See *MH-I*, Chapter 4, Museum Collections Environment.
 - Establish and maintain an Integrated Pest Management program. See *MH-I*, Chapter 5, Biological Infestations.
 - Establish and implement security and fire protection procedures. See *MH-I*, Chapter 9, Museum Collection Security and Fire Protection.

Deterioration of museum collections can't be totally halted, only slowed. Access and use must be provided and encouraged, while preserving and protecting the collections.

3. *How do I allow access to and use of collections?*

Access and use of collections must be done systematically in order to minimize the risks of:

- theft
- mishandling
- vandalism
- lawsuits due to intellectual property rights infringements, such as copyright or privacy infringements
- letters of complaint to Congress and superintendents resulting in investigations and audits

For further guidance, see *MH-I*, Chapter 9, Museum Collections Security and Fire Protection and Appendix G, Protection of NPS Museum Collections, and *MH-II*, Appendix D, Museum Archives and Manuscript Collections.

4. *What steps are necessary for providing access to and use of collections without critically affecting collection preservation?*

To effectively balance preservation and use of the park's museum collections, you must follow the standard management steps listed below:

- Review your collection restrictions for legality under FOIA, state Sunshine laws, Archeological Resources Protection Act (ARPA), and other laws outlined in *MH-III*, Chapter 2, *before* you provide access.
- Decide access and use policies and procedures *before* you provide access.
- Train all staff how to apply and follow these policies and procedures (including worst case scenarios, such as how to react in case of theft, vandalism, lawsuits, and mishandling) *before* they provide access.
- Make sure the park staff have and understand how to use all necessary forms for access and use, including forms for researcher registration, copyright and privacy legislation, model and interview releases, and duplication *before* providing access. See *MH-II*, Appendix D.
- Ensure the park staff understand that all researchers, *including park staff*, must be monitored while using collections.
- Show researchers how to handle and use museum collections when they first register to use collections. (*Note:* To simplify this task, you may want to ask the researcher to view a videotape or Web site on this topic.)
- Provide an appropriate space for use as a research or reading room.
- Provide adequate space in the research room for needed research equipment.
- Ensure that researchers sign all forms, such as researcher registration forms, copyright and privacy statements, and researcher duplication forms, so that NPS is protected from potential legal problems and so researchers can be held legally liable for any mishandling.
- Pay attention to how researchers handle materials and tactfully correct any handling problems.
- Monitor and manage your research or reading room environment. See *MH-III*, Appendix D, Guidance on Planning for a Research Space.
- Never store collections in the research room.
- Don't provide access in storage rooms (even if collections are in locked cabinets).

Never leave any researcher unsupervised or unmonitored in areas with collection materials.

5. *How do I assess physical condition?*

Use the following tools to help assess the condition of your park's museum collection:

- ***The Collection Management Plan (CMP)*** provides both short- and long-term guidance to parks for managing and caring for objects. The CMP assesses the park's collection management program, identifies problems, and recommends corrections. The subsequent action plan developed by the park identifies and prioritizes corrective actions and specifies needed resources. See *MH-I*, Chapter 3, Museum Objects Preservation, and Appendix F, Museum Collection Management Checklists.
- ***The Collection Condition Survey (CCS)*** is an assessment of the condition of the objects in a collection by a qualified conservator. It looks at objects either individually or in groups of similar materials and their treatment needs. The survey explores the factors that can affect the collections, including ways that collections are used in exhibits, interpretation, education, and research. The report can be used as a tool to develop a systematic approach to improving the conditions of collections and create a baseline for future assessments of object deterioration. See *MH-I*, Chapter 3, Museum Objects Preservation.
- ***The Archival Assessment***, which can be completed as part of a CMP or on its own, evaluates a park's archival and manuscript collection management needs, incorporating collection surveys and evaluations. See *MH-II*, Appendix D, Museum Archives and Manuscript Collections. The survey reports and recommendations from this assessment can help you evaluate the condition of your archival and manuscript collections.
- ***The Object Condition Report and Object Treatment Report*** are prepared by a conservator before and after conservation treatment of an object. The Condition Report provides a description of the materials, structure, and condition of the object based on any observed deterioration and is also used to document the condition of an object before and after loan, exhibit, or other activities. The Treatment Report describes the procedures, materials, method, and extent of treatment. See *MH-I*, Chapter 8, Museum Object Conservation Treatment. The curator keeps these completed reports in the accession or catalog folder, where they can be consulted to determine object condition when a use proposal is received.
- ***Developing a critical eye*** is a skill learned through experience and training for evaluating object condition. This is discussed in *MH-I*, Chapter 4, Museum Collections Environment, Section B. Over time you can become expert in assessing visual clues that signal an object's condition.

6. *How do I assess physical and mechanical preservation risks associated with the proposed use and how can I prevent damage?*

Physical damage includes:

- melting
- burning
- warping
- buckling
- shrinking
- softening binders, such as gelatin or albumen

This type of deterioration results from poor or widely fluctuating climatic conditions.

Prevent physical damage by stabilizing climatic conditions.

Mechanical damage includes:

- tearing, breaking, cracking, or chipping
- scratching or abrading
- soiling or smudging
- creasing or wrinkling

This type of deterioration results from careless and improper object handling and use, neglect, or vandalism.

Prevent mechanical damage by following this advice.

- Make sure that users know your handling policies and procedures. For General Rules on Handling Museum Objects, see *MH-I*, Chapter 6, Handling, Packing, and Shipping, Section C.
- Provide users with a clean, stable, and well-lighted environment.
- Don't allow pens, knives, or similar materials where objects are being used.
- Require and provide No. 2 graphite pencils for notetaking.
- Require researchers to wash their hands and wear gloves, as appropriate, when working with museum collections.
- Register and continuously monitor all researchers
- If you find any signs of vandalism or theft, such as illustrations cut out of historic volumes, check the registration records and determine who has used the collection. Look for a pattern in the damage. If only one

researcher had access to the particular object or collection, this tells you who might have stolen or damaged the material. Contact NPS law enforcement and your SO curator who will inform other parks to watch for this individual.

7. *What are the chemical risks and how can they be avoided?*

Chemical damage includes:

- oxidation, such as rusting
- corrosion
- damage to pigments
- some staining

This type of damage is caused by reaction to another chemical, such as air pollution or oils from a user's hands.

Photochemical damage includes:

- some staining
- color shifts
- fading
- flaking media
- embrittlement of textiles and paper

This type of damage is caused by exposure to excessive light levels.

Chemical risks associated with use can be avoided by following this advice.

- Monitor and manage your storage, work, exhibition, and research room environments.
- Establish a light monitoring program in exhibit and research areas. Correct light levels that exceed standards. See *MH-I*, Chapter 4, Museum Collections Environment, Section E.
- Follow the guidelines in *MH-I*, and the *COGs* for specific types of material.
- Limit the level and duration of light in all museum spaces.

8. *What are the biological risks and how can they be avoided?*

Biological damage includes:

- mold and fungal growth
- insect damage or residue

- rats, squirrels, mice, and other vermin damage or residue

Prevent biological damage by doing the following:

- Don't allow smoking, drinking, eating, chewing, or similar activity in the research room.
- Institute an Integrated Pest Management Program.
- Keep plants and animals out of storage, exhibition areas, research rooms, and work spaces.
- Monitor and manage your storage, exhibition areas, work space, and research room environments.
- Follow the guidelines in *MH-I*, Chapter 5, Biological Infestations, and the COGs for specific types of material.

9. *What are the security risks associated with the proposed use?*

Security problems may include:

- collection vandalism, such as ripping, marking, or damaging collections

Follow the procedures described above and in Question 6.

- theft by staff or outside researchers

Contact NPS law enforcement staff and SO curator immediately. Assemble all pertinent accession and catalog records, as well as researcher registration documentation on researchers who have requested access to the stolen materials during the last several years. See *MH-II*, Chapter 4, Inventory and Other Special Instructions, Section III on loss.

- misplacement or temporary loss of collection materials

Look at which researchers used the materials most recently. Identify what other collections they worked with and check those locations. If you still can't find the missing materials, assemble all researcher registration and use information and contact your law enforcement officer and SO curator.

- damage during loans

See *MH-II*, Chapter 5, Outgoing Loans.

- damage during transportation

See *MH-I*, Chapter 6, Handling, Packing and Shipping Museum Objects.

- damage during exhibitions, especially in open display and furnished historic structures without protective enclosures

Except for historic period settings, this open display technique should be avoided.

- damage during duplication

See *COG 19/12 Contracting for Reformatting of Photographs*.

- arson and fire damage

See *MH-I*, Chapter 9, Museum Collections Security and Fire Protection.

10. *How do I prevent security problems?*

Security problems can be avoided or minimized when you follow the guidance below:

- Provide continuously supervised access to museum collections. If supervision is not possible, you may refuse access if the refusal is temporary and applied equally to all researchers, including staff. See *MH-I*, Chapter 9, Museum Collections Security and Fire Protection, and *MH-II*, Appendix D, Museum Archives and Manuscript Collections, Sections T and U.
- Restrict access to unaccessioned and uncataloged museum collections and to not yet cataloged, described, arranged, or rehoused archival and manuscript materials. You may refuse access if the refusal is temporary and applied equally to all researchers, including staff.
- Provide additional supervision for access to original, high value, highly collectible, or similar objects (for example autograph materials, gold jewelry). Limit the number of objects to one or a few that you provide at one time to researchers, or make photographs or reproductions (such as digital, xerographic, or microfilm copies) available for use.
- Refuse access to researchers with a record of thievery or vandalism towards museum, archival, or library collections. Contact organizations listed in *MH-II*, Chapter 4, Section C, Reporting Loss of Museum Objects, to get information on convicted thieves and vandals. In the case of the destructive individual or documented thief, consult with your NPS law enforcement staff, the SO curator, and the NPS solicitor for remedies.
- Develop and implement researcher (including staff) registration procedures. See Section J, Documentation.
- Establish and implement research room operating procedures for monitoring and duplication. See *MH-II*, Appendix D, Museum Archives and Manuscript Collections.
- Follow outgoing loan procedures. See *MH-II*, Chapter 5, Outgoing Loans.

- Establish and follow exhibition procedures. See *MH-III*, Chapter 7, Using Museum Objects in Exhibits (in prep).
- Implement duplication forms and procedures. See *MH-II*, Appendix D, Museum Archives and Manuscript Collections.

11. *How do I deal with a disturbed, thieving, or destructive individual?*

Beyond the security issues described above, you may have to deal occasionally with angry, dissatisfied, or disgruntled visitors. When this occurs, you must follow these procedures:

- Ask for back-up from another collections person, so you have a witness.
- Locate another staff member to handle the research room.
- React in a calm, empathic, and tactful manner, without yelling or arguing.
- Determine what the researcher's concern is and restate the concern, so it is clear you understand it.
- Calmly inform the visitor of the NPS policy or procedure that covers the situation.
- Tell your visitor that you are expected to execute the procedure or policy the same way for all visitors.
- Explain that you are personally held accountable by a supervisor for applying the procedure equitably.
- Offer to show the visitor the policy or procedure.
- Offer to take the visitor to your park's public affairs officer or park ranger headquarters.
- Encourage the visitor to leave the research room, but **don't** touch the individual.
- Call the park law enforcement officers to defuse the situation if the individual becomes violent or abusive. Ideally ask the person to step outside and then lock the door to the research room. Notify the park public relations officer.

12. *How do I deal with staff theft?*

Don't confront the suspect. The thief may destroy essential collections documentation or hurt you. Report your concerns, with related facts or documentation, to law enforcement and the individual's supervisor or the park superintendent.

The supervisor and park superintendent will determine if the individual should be placed on administrative or other leave during the investigation. The suspect must be given a chance to clear his or her name without placing any portion of the museum collection at risk.

If a theft occurs, gather all appropriate collections documentation to indicate what was stolen, including catalog records, inventories, and researcher registration information. Follow the guidelines in *MH-II*, Chapter 4, Inventory and Other Special Instructions, Section III, Reporting Loss of Museum Objects.

Don't try to hide thefts. Work with NPS law enforcement officers, solicitors, and other museums, archives, dealers, and professionals to recover your stolen materials.

13. *How do I use a facilities report to evaluate risk?*

When your museum receives a loan request, you should request a completed facility report from the borrowing institution. See *MH-II*, Chapter 5, Outgoing Loans. This report details that institution's physical condition and the standard practices of its staff. It can uncover potential security, handling, or environmental problems that can be resolved before the loan is made.

A facility report typically provides information about the borrower's environmental controls, security, fire protection, and ability to care for and handle collections. You can use this information to determine the risk of lending the object by verifying the borrower will care for your objects properly. See *MH-II*, Chapter 5, Outgoing Loans. A standard facility report is published by the American Association of Museums Registrars Committee. Parks can contact NPS Museum Management Program for a copy.

14. *How do I protect objects from overuse?*

Monitor collection use. Refer to the researcher log book and researcher registration forms to determine frequency of use of a particular collection or object.

Look at the level of light exposure the objects are receiving. See *MH-I*, Chapter 4, Museum Collections Environment. If fragile or vulnerable materials are exposed to light levels exceeding those recommended for exhibitions, consider reformatting the materials via digital and microfilm copies.

Rotate objects on exhibit. See *MH-III*, Chapter 7, Using Museum Objects in Exhibits (in prep.).

If microfilm and digital copies are not an option, consider producing a master set of xerographic copies on acid-free paper of high-use materials. For three-dimensional materials, have high-quality record photographs made and later scanned for use.

If certain archival collections are heavily used for research or duplication for more than a month, have them reformatted into microfilm and digital formats for access. The original can then be retired to the museum storage space for preservation.

Computer software manufacturers are developing ways to turn digitized files of photographs into "virtual" museum objects so you may provide three-dimensional reference files of museum objects in CD-ROMS, on your hard drive, or on the World Wide Web. This technology makes your collections accessible to a wider audience.

15. *What do I do if objects are damaged?*
- If an object is broken or damaged during use, return the object to storage until it can be stabilized and treated. Document damage on the catalog card and supplement with photographs. If the item is destroyed, follow the guidance in *MH-II*, Chapter 4, Section III, Reporting Loss of Museum Objects. Consult a conservator for treatment recommendations.

Damaged archival and manuscript items must be stabilized before they may be made available. If the damaged item forms part of a group of materials (for example, one document in a box of archival documents), replace it with a separation sheet and a xerographic copy. The separation sheet will indicate the new storage location of the item. Put the damaged original in safe storage until it can be treated by a conservator. See *MH-II*, Appendix D, Museum Archives and Manuscript Collections.

16. *How do I recognize over-use?*
- When materials show obvious damage, such as fading, wrinkling, tearing, smearing, surface losses, abrading, wear, or other damage discussed in Question 4, they are being over-used. When reviewing accession or catalog files or the researcher log book, if you notice repeated use by researchers of the same object or collection, you should examine these items immediately for signs of wear.

By monitoring files and log books and inspecting object condition as they are returned to storage following use, you may anticipate potential over-use before objects reach this state. Consult a conservator if you question whether an object has become too fragile or vulnerable for further use without treatment.

H. Interpretation Issues

1. *What is NPS interpretation?*
- Interpretation links park resources and the values, ideas, and meanings of the people who used them. The goal of NPS interpretation is to allow visitors to forge relationships with NPS resources. Museum collections are both park resources and a means to interpret and further the mission of the park and the NPS Servicewide.

2. *What is the NPS interpreter's role in using museum collections?*
- The interpreter's role is to help visitors discover some of the uses of and values represented by the resources they see and experience in the park. You should work with interpretive staff to make museum collections a vital part of the park's interpretive program to:

. . . assure that the interpretive process manifests a variety of cultural and intellectual perspectives and reflects an appreciation for the diversity of the museums' public dimension.

as noted in the 1992 American Association of Museums report *Excellence and Equity, Education and the Public Dimension of Museums*.

The museum collections are part of a park's fabric. Museum collections enrich our knowledge, understanding, and appreciation of the park's mission and goals. The interpreter helps the visitor appreciate and understand park resources so that:

Objects are no longer viewed solely as things in themselves, but as things with complex contexts and associated value-laden significance . . . Changing interpretive approaches will have a strong impact on museum collections and the public's understanding of them . . .

Excellence and Equity, Education and the Public Dimension of Museums, American Association of Museums.

Effective NPS interpretation should help the visitor connect the objects, the people who used them, collections research, and the park mission. Museum collections interpretation should provide "enriching experiences through the interaction of objects and ideas."

3. *How do I determine the appropriateness of the proposed use?*

You can use objects effectively in educational and interpretive programs. Museum collections are park resources, but they also help to convey to the visitor the park's history and mission.

Use the following considerations to determine if an object is appropriate and an effective means to meet your interpretive objectives.

- Value-related considerations

Determine:

- what specific linkages you're trying to convey through the use of the objects
- if these relationships are connected to your specific interpretive themes and the NPS thematic framework (see *Revision of the National Park Service' Thematic Framework*, 1996)
- if use of objects will improve significantly the visitors' understanding of the park's mission, goal, history, and resources
- if the proposed use respects the creator's (if any) intent, original use, and context of the objects, or if it recognizes its original setting and association with other objects
- if you know enough about the objects to use them accurately and sensitively
- if the information you plan to share about the objects is accurate and balanced
- if the information is current and from authoritative sources

- Condition-related considerations

Determine:

- if the objects can be used or displayed safely without risking loss or damage
- if all who will work with the materials have been taught appropriate handling and use procedures, and have been appropriately and continuously supervised in such use
- if you have enough objects that meet the theme-related requirements listed above to skip using a fragile piece
- if you can use a variety of objects in a regular rotation to lessen damage from over-exposure or handling of any one object

4. *Are there alternatives to using the proposed object?*

You need to ask whether there is a viable alternative to using this particular object. The alternative may be recommending using a similar but less fragile or valuable object, or a reproduction item. You should then ask if an original object is essential for the link you are trying to convey, or could a reproduction or other representation be substituted effectively?

I. User Qualifications

1. *What credentials must users present when requesting access to collections?*

Since museum objects and museum archival and manuscript collections have different access and use traditions, access is different for the two types of collections.

- Museum Objects

Museums traditionally provide collections access to scholars, private individuals, and staff by appointment. The public generally has access to museum collections through exhibitions, catalogs, educational programs, and multimedia. In the last decade museums have moved toward providing access to a broader spectrum of the public with learning centers, interpretive programs, and electronic and interactive access.

Museums require some information on a researcher's background sufficient to evaluate whether the proposed use is appropriate. This background information includes:

- the presentation of credentials (such as university affiliation and drivers license)
- a request for an appointment to obtain museum collection access briefly outlining:

researcher's name, address, institutional affiliation, if applicable

project summary (the topics and materials to be studied and methodology)

project duration

publication plans

special support needs, such as photography of objects

All users must complete a researcher registration form accompanied by showing a drivers license or other picture identification.

Evaluate each request, and, if appropriate, arrange for the researcher to use the collection. The user completes and signs forms outlined in Section J, Documentation.

- Museum Archival and Manuscript Collections

Museum archival and manuscript collections come out of the archives and library access and use tradition. Most state and federal archives and libraries provide access to all.

The only individuals restricted from using the collections are those who previously have stolen or vandalized archival collections. Professional organizations of archivists and librarians, such as the Society of American Archivists circulate information on convicted thieves and vandals. The only archival access requirement is that the archives must have something on the topic being researched and the researcher has a demonstrated need for primary source material. See *MH-II*, Appendix D, Museum Archives and Manuscript Collection.

Sheer curiosity is not a demonstrated need for handling original archival materials. Courteously show curious visitors exhibitions, publications, and reformatted copies, but don't allow them to handle original materials (except for research and those materials approved for consumptive use), as extensive handling affects the life of collections.

Archives generally require that the documents listed in Section J, Documentation, be completed and signed.

2. *How would the user's qualifications affect an access request?*

The weight of user qualification on whether a researcher gains access to collections depends upon whether the request is for use of museum objects or archival and manuscript collections. In the cases of both museum and archival research, an appointment for research may be necessary, such as when a park has limited space or staff or the objects require conservation treatment.

- Museum Objects

Museum collections are available to any user as long as the use does not endanger the object's preservation and security, conflict with federal or state legislation, or NPS policy.

- Museum Archival and Manuscript Collections

By state and federal law all, visitors and researchers may have access to all museum archival and manuscript collections (with a few specific statutory or donor-specific restrictions). The user's qualifications have no effect.

There are no systematic excuses for refusing access. Parks must provide good-faith attempts to make their archival and manuscript collections available. Every attempt should be made to provide prompt, courteous, and accurate reference support.

J. Documentation

1. *How do I document access and use of collections?*

Don't provide access to the collections until the following documents are completed.

- Researcher Logbook

Maintain a researcher logbook and require the researcher to sign each time he enters or leaves the research room. See *MH-I*, Appendix G, Museum Collection Protection, Figure G.6, Sample Visitor Log, and G.7, Conditions for Access to Museum Collections; and *MH-II*, Appendix D, Museum Archives and Manuscript Collections.

- Access Policies and Rules Governing Use Statement

When entering a museum's research room, this is the first document the researcher sees. This statement provides a clear concise overview of the museum's rules on access, citations, research room rules, permission to publish requirements, and handling policies. The researcher must read and sign this statement before he can register to use the collection.

See *MH-I*, Appendix G, Figure G.5, Sample Park Museum Collection Access Policy and Procedures and *MH-II*, Appendix D, Figure D.13a-b, Access Policies and Rules Governing Use for a sample statement.

- Researcher Registration Form

After reading the Access Policies and Rules Governing Use, the researcher must complete a Researcher Registration Form.

A Researcher Registration Form includes the date and information about the researcher, institutional affiliation, and a summary of the research project and publication plans. The names of the collections used, and boxes of archival collections used and the name and accession numbers of the museum objects viewed are noted on the reverse of the form. See *MH-II*, Appendix D, Figure D.16.

- Copyright and Privacy Restriction Statement

Immediately after registering, the researcher reads and signs a Copyright/Privacy Restriction Statement. This statement explains the legal uses of park collections under the copyright and privacy acts, and alerts the researcher about misuse of protected materials.

The document contains an indemnification statement holding the researcher legally liable for any misuse and indemnifying the NPS from all claims, demands, losses, and damages arising out of legal actions due to the researcher's misuse of materials. This researcher signs this statement prior to collection use. See *MH-II*, Appendix D, Figure D.15.

- Duplication Forms

When the researcher requests photographic or xerographic (photocopies) copies or equivalent digital files, microfilm, or other copies, the researcher completes a Researcher Duplication Form. This form includes the researcher's name, date the order was filled and who filled it, reason for the copies (such as publication, research), special duplication needs (for example, rush orders, blow-ups), and material to be copied (collection, location, description, and number and type of copy).

A Duplication Form contains an indemnification statement, holding the researcher responsible for all illegal use of the material and indemnifying the park from any legal liability resulting from misuse. The researcher signs and dates this statement before duplication takes place. See *MH-II*, Appendix D, Figure D.14.

2. *When should I use an outgoing loan agreement?*

You can lend museum objects from the park museum collection for a variety of purposes. These include:

- exhibition
- research
- scientific or exhibit preparation
- analysis
- photography
- conservation or other services requested by the park

Museum collections also are loaned for long-term collections management and storage. You must use an outgoing loan agreement whenever you generate an outgoing loan transaction. Refer to *MH-II*, Chapter 5, Outgoing Loans for detailed information on outgoing loans.

K. Checklist: Evaluating a Request to Use Museum Objects

[Park Name/Address]

Requested by: Name: _____ Title: _____

Institution: _____ Date requested: _____

Address: _____

Tel/e-mail: _____

Staff evaluator: Name: _____ Title: _____

Proposed use is for: Publication Exhibit Interpretation/Education Research Project Destructive Analysis Other
Explain:

Benefits to: Park/NPS Association group User Discipline/Profession Other
Explain:

Laws affecting this request: Copyright FOIA Privacy Publicity Case law Other
Explain:

Management issues: User supervision available Work space available Associated data can be used
Objects are: Accessioned Cataloged Entered in ANCS
Data needs to be restricted. Explain:

Ethical issues: Employee ethics concerns Professional ethics concerns
Explain:

Cultural concerns: Affect use of natural history collections Sensitive issues related to associated groups
Religious concerns Consultation with traditionally associated groups
Explain:

Scientific uses: Type specimens Voucher specimens Threatened and endangered species
Explain:

Preservation and protection issues: Borrowing institution facility meets NPS outgoing loan standards
The object is in good physical condition appropriate for the proposed use
There are: Mechanical risks Biological risks Chemical risks Security risks
Explain:

Interpretation issues: Object essential for proposed use Traditionally associated group's concerns respected
Alternatives to using proposed object: Photograph Reproduction Microfilm Digital copy Other
None:
Explain:

Documentation issues (Forms Completed): Researcher Registration Copyright/Privacy Statement
Duplication Form Outgoing Loan Other
Explain:

The User: Presented credentials Agrees to provide _____courtesy copies to the park
Agrees to provide the following additional items for the park: Digital copies Posters Other:
Explain:

User publication plans are:

Agrees to credit the park as follows:

Approved by _____ Title _____ Date _____

L. Bibliography

American Association of Museums: *Code of Ethics for Museums*. Washington, D.C.: American Association of Museums, 1994.

_____. *Excellence and Equity, Education and the Public Dimension of Museums*. Washington, D.C.: American Association of Museums, 1992.

_____. *Revised Standard Facility Report*. Washington, D.C.: American Association of Museums, 1998.

American Historical Association. *Statement of Standards of Professional Conduct*. Washington, D.C.: American Historical Association, 1992.

- American Library Association and Society of American Archivists. *ALA-SAA Joint Statement on Access to Original Research Materials in Libraries, Archives, and Manuscript Repositories*, undated.
- Anderson, Carolyn, and Thomas W. Benson. "Direct Cinema and the Myth of Informed Consent: The Case of Titcut Follies." In *Image Ethics: The Moral Rights of Subjects in Photographs, Film, and Television*, edited by Larry Gross, John S. Katz, and Jay Ruby, 58-90. New York: Oxford University Press, 1988.
- Aoki, Keith. "(Intellectual) Property and Sovereignty: Notes Toward a Cultural Geography of Authorship." *Stanford Law Review* 48, no 5 (1996): 1293-1355.
- Ardito, Stephanie. "The Information Broker and Intellectual Property Rights." *Bulletin of the American Society for Information Science* 21, no 3 (February/March 1995): 19-20.
- Association of Systematics Collections. *Guidelines for Institutional Policies and Planning Natural History Collections*. Washington, D.C.: Association of Systematics Collections, 1994.
- Barlow, John Perry. "Selling Wine Without Bottles: The Economy of Mind on the Global Net." <http://www.eff.org/pub/Intellectual_property> Accessed 1 January 1996.
- Boyle, James. *Shamans, Software, and Spleens: Law and the Construction of the Information Society*. Cambridge, Mass.: Harvard University Press, 1996.
- Brandt, Elizabeth A. "On Secrecy and the Control of Knowledge: Taos Pueblo." In *Secrecy: A Cross-Cultural Perspective*, edited by Stanton K. Tefft, 123-146. New York: Human Sciences Press, 1980.
- Brown, Michael. *The Channeling Zone: American Spirituality in an Anxious Age*. Cambridge, Mass.: Harvard University Press, 1997.
- Brush, Stephen B. "Indigenous Knowledge of Biological Resources and Intellectual Property Rights: The Role of Anthropology." *American Anthropologist* 95, no. 3 (1993): 653-686.
- Daes, Erica-Irene. *Study on the Protection of the Cultural and Intellectual Property of Indigenous Peoples*. New York: United Nations Economic and Social Council, Commission on Human Rights, 1993.
- Dowler, Lawrence. "The Role of Use in Defining Archival Practice and Principles: A Research Agenda for the Availability and Use of Records." *American Archivist* 51 (Spring 1988): 74-86.
- Fowler, Catherine. "Ethical Considerations." In *Preserving the Anthropological Record*, 2d edition, edited by Sydel Silverman and Nancy J. Parezo, 63-72. New York: Wenner-Gren Foundation for Anthropological Research, Inc, 1995.
- Golvan, Colin. "Aboriginal Art and the Protection of Indigenous Cultural Rights." *European Intellectual Property Review* 14, no. 7 (1992): 227-232.
- Inter-Apache Summit on Repatriation. "Inter-Apache Policy on Repatriation and the Protection of Apache Cultures." Unpublished document, 1995.
- International Council of Museums. *Code of Professional Ethics*. Paris: ICOM, Maison de l'UNESCO, 1996.
- Kepley, David R. "Reference Service and Access." In *Managing Archives and Archival Institutions*, edited by James Gregory Bradsher, 228-240. London: Mansell Publishing, 1988.
- Lee, Welton, ed. *Guidelines for Acquisition and Management of Biological Specimens*. Washington, D.C.: Association of Systematics Collections, 1982.
- MacNeil, Heather. *Without Consent: The Ethics of Disclosing Personal Information in Public Archives*. Metuchen, NPS Museum Handbook, Part III (1998)

- N.J.: Scarecrow Press, 1992.
- Munro, Doug. "Who 'Owns' Pacific History?" *The Journal of Pacific History* 29, no 2 (1994): 232-237.
- Posey, Darrell A., and Graham Dutfield. *Beyond Intellectual Property: Toward Traditional Resource Rights for Indigenous Peoples and Local Communities*. Ottawa, Canada: International Development Research Centre, 1996.
- Pugh, Mary Jo. *Archival Fundamentals: Providing Reference Services*. Chicago: Society of American Archivists, 1992.
- Ruth, Janice E. "Educating the Reference Archivist." *American Archivist* 51 (Summer 1988): 266-276.
- Sandager, Elizabeth. "Ethical Implications of the Documentary Record." *New England Archivists Newsletter* 2, no. 2 (1994): 4-6.
- Society for the Preservation of Natural History Collections. "Guidelines for the Care of Natural History Collections." *Collection Forum* 10, no. 1 (1994): 32-40.
- Society of American Archivists. *SAA Code of Ethics for Archivists*. Chicago: Society of American Archivists, 1992.
- Strathern, Marilyn. "Potential Property: Intellectual Rights and Property in Persons." *Social Anthropology* 4, no. 1 (1996): 17-32.
- Warren, Karen J. "A Philosophical Perspective on the Ethics and Resolution of Cultural Property Issues." In *The Ethics of Collecting Cultural Property: Whose Culture? Whose Property?* edited by Phyllis Mauch Messenger, 1-26. Albuquerque, N.Mex.: University of New Mexico Press, 1989.
- Whalen, Lucille, ed. *Reference Services in Archives*. New York: The Haworth Press, 1986.
- Ziff, Bruce, and Pratima V. Rao, eds. *Borrowed Power: Essays on Cultural Appropriation*. New Brunswick, N.J.: Rutgers University Press, 1997.

Chapter 2: Legal Issues

Page

A. Overview	2:1
What does this chapter cover?	2:1
Where can I get additional information on these laws?.....	2:1
What are some frequently asked questions?.....	2:1
B. Access and Use Legislation	2:5
What laws affect the use of museum collections?	2:5
How do I address reference questions involving legal issues?	2:6
C. Copyright Laws	2:6
What is copyright?.....	2:6
What laws make up copyright?	2:7
What is covered by copyright?.....	2:7
Can a person copyright an idea or fact?.....	2:8
What is not protected by copyright?.....	2:8
Why are federal employees' works not protected by copyright?.....	2:8
Are the works of federal contractors, cooperators, partners, and volunteers protected by copyright?	2:9
When do copyright protections become active?	2:10
What is the duration of copyright protection?.....	2:10
When do I need to get copyright permissions?	2:12
What information do I need in order to obtain permission from the copyright owner?.....	2:13
If the park owns the material physically, does it also own the copyrights?.....	2:13
If the park doesn't own the copyright, but I want to use the materials in a publication, what do I do?	2:14
Can copyright be restored once it has lapsed?	2:15
What is fair use?.....	2:15
What criteria determine fair use?	2:16
How does fair use exemption impact me?.....	2:17
Are there additional copyright exemptions besides fair use?.....	2:18
What should I do if I'm uncertain of the copyright status of a work and the fair use quality of a reference request?.....	2:19
Is fair use different in a networked electronic environment?.....	2:21
Why and when must I place copyright notices on copies and copiers?.....	2:23
How do I handle unpublished materials?	2:24
What is the public domain?	2:24
When is a work in the public domain?	2:24
What is the right of "first sale"?.....	2:25
What are visual artist's moral rights?	2:25
D. Freedom of Information Act	2:25
What is the Freedom of Information Act (5 USC 552)?	2:25
What are federal records?.....	2:25
How does FOIA affect park museum collections?	2:26
What must I provide under FOIA?	2:26
What don't I have to provide under FOIA?	2:27
What do I do if I receive a FOIA request?.....	2:28
E. Location Information	2:28
How does the Archeological Resources Protection Act (ARPA) of 1979 (16 USC 470) affect use?	2:28
How does the National Historic Preservation Act of 1966, as amended	

16 USC 470-470t, 110) affect use?	2:29
How does the Executive Order 13007—Indian Sacred Sites (May 24, 1996) affect use?	2:30
How does the Federal Cave Resources Protection Act of 1988 (16 USC 4301-4309) affect use?	2:30
What do I need to know about the National Parks Omnibus Management Act of 1998 (PL105-391)	2:30
What do I need to know about the Endangered Species Act of 1973 as amended (16 USC 1531-1543)?	2:31
What do I need to know about protecting the location of paleontological sites?	2:31
F. Privacy and Publicity Legislation	2:31
How does privacy legislation (5 USC 552) affect park museum collections?	2:31
Who has little or no right to privacy?	2:33
What is covered under the right to privacy?	2:34
May I provide private information for fair use, such as education and research?	2:35
How does privacy law affect museum or archival collections?	2:35
How do I avoid rights problems when producing new products, such as photos?	2:35
How do I avoid rights problems when using old photographs and related materials?	2:36
What should I do if I have materials without signed releases?	2:36
How do the courts enforce state privacy laws?	2:37
What is the difference between publicity and privacy laws?	2:37
How do I know if use is potentially illegal?	2:38
How does publicity legislation affect park museum collections?	2:38
G. Other Legal Issues	2:38
How do donor restrictions affect use?	2:38
What is meant by sensitive information?	2:39
What slander and libel laws affect use of museum collections?	2:39
What is obscenity, and how does it concern museum collections?	2:39
What pictures of nudes are exempt from obscenity concerns?	2:40
How can I manage nude images that I have in my collection?	2:40
How does evolving case law affect my practices?	2:40
Do restrictions for National Defense, Foreign Policy, and Classified Data affect museum collection use?	2:40
What are the restrictions for access to Internal Personnel Rules and Practices?	2:40
H. Patent Laws	2:40
What are patents?	2:40
How do patents protect inventions?	2:41
What can be protected by patents?	2:41
How do patents affect museums and scholars?	2:41
What is the period of patent protection?	2:41
I. Trademarks and Servicemarks	2:41
What are trademarks?	2:41
How are trademarks different from servicemarks?	2:41
Why do businesses have trademarks and servicemarks?	2:41
How do trademarks and servicemarks affect museums?	2:41
Must I register for trademark and servicemark protection?	2:42
How long do trademark and servicemark protections last?	2:42
J. List of Figures	2:42
K. Bibliography	2:51

CHAPTER 2: LEGAL ISSUES

A. Overview

1. *What does this chapter cover?*

This chapter lists and discusses the laws, regulations and other legal guidance that affect access and use of NPS museum and archival collections.
2. *Where can I get additional information on these laws?*

For a quick summary, see *Museum Handbook*, Part II (*MH-II*), Appendix A: Mandates and Standards for NPS Museum Collection Management. Many law school libraries have collections on these topics. An easy way to get an overview of applicable laws is to view the web sites in the bibliography, particularly the following, listed alphabetically:

 - American Association of Museums Registrars Committee Rights and Reproductions Information Network (RARIN) at <http://www.panix.com/~squigle/rarin/01rsite.ht>
 - Copyright charts: www.copyright.cornell.edu/training/Hirtle_Public_Domain.html
 - Fair Use guidelines by documentary filmmakers, <http://www.centerforsocialmedia.org/rock/backgrounddocs/bestpractices.pdf>
 - Harvard University's Intellectual Property Primers at <http://cyber.law.harvard.edu/property/library/primerlib.html>
 - Legislation section of the NPS web site at <http://www.cr.nps.gov/linklaws.htm>
 - National Humanities Alliance's Basic Principles for Managing Intellectual Property in the Digital Environment at <http://www.ninch.org/#issues>
 - University of California at Berkeley's Copyright, Intellectual Property Rights, and Licensing Issues at <http://sunsite.berkeley.edu/Copyright/>
 - University of Texas at Austin's Copyright Crash Course at <http://www.utsystem.edu/ogc/intellectualproperty/cprtindx.htm>
 - Zorich, Diane, "Developing Intellectual Property Policies: A How To Guide for Museums" and Bibliography (2003) http://www.chin.gc.ca/English/Intellectual_Property/Developing_Policies/index.html

If Internet addresses should change, search on the keywords in the above Web addresses.
3. *What are some frequently asked questions?*

This section includes some recommendations on how to respond to frequently asked questions. Consult with your regional curator and the NPS solicitor or with the Park Museum Management Program office if

you have any concerns or are unsure of how to respond.

<p>1. <i>What do I need to know when considering requests to access and use collections?</i></p>	<p>Before responding to a request, find answers to the following questions:</p> <ul style="list-style-type: none"> • Who owns the material? • Is there a title transfer document in the accession folder? • Is the material copyrighted? • Will release of information make the resource, both the object itself and other park resources, vulnerable? • If so, what laws and regulations protect the resource? <p>This chapter provides guidance on how to respond to these questions. Consult with your regional curator or the NPS solicitor through the Park Museum Management Program, if you have any questions.</p>
<p>2. <i>How do I handle an NPS investigator's field notes, raw data, and unpublished manuscripts?</i></p>	<p>Field notes, raw data and unpublished manuscripts created by NPS employees within the scope of their employment are not protected by copyright and are, for purposes of copyright, in the public domain. (See 2.C.6). In general, requests to access or publish such materials may be granted.</p> <p>These materials, however, may be 'pre-decisional' and part of park planning efforts and not appropriate for public release under FOIA or other requests (2.D.4); or specific information may need to be withheld in accordance with the Archeological Resources Protection Act, the National Historic Preservation Act [see B.1.], National Parks Omnibus Management Act, or other legislation (see D.5.). Other factors, such as privacy laws (see F.1.), should be considered before granting permission to access or publish NPS-created materials.</p>
<p>3. <i>How do I handle a non-NPS investigator's field notes, raw data, and unpublished manuscripts?</i></p>	<p>While many permits, contracts, and agreements that NPS issues or signs include provisions that allow NPS to acquire field notes and other research products, you need to review the terms of the actual issued permit, contract, or agreement to determine the extent to which NPS may use such materials. Work with the responsible park staff to ensure that permits, contracts, and agreements that result in a collection 1) include a request for field notes and other research materials; and 2) specify unrestricted NPS use of the materials. See section C.7.</p> <p>Field notes, raw data and unpublished manuscripts created by non-NPS permittees doing research on NPS land and obtained by NPS through permit conditions may be subject to copyright protection. In most cases, the permittee is considered the creator or author of the work. Field notes and unpublished manuscripts likely have copyright protection. (See 2.C.23). The creators may donate their copyright to NPS.</p>

	<p>Generally, raw data itself will have little or no copyright protection (See 2.C.4). The presentation of raw data, if expressed in a unique manner, may have some copyright protection. However, raw data may contain sensitive information, which if disclosed, might harm the resource, and may be subject to other legislation that protects location information (see section E.).</p> <p>In general, requests to access such materials do not have copyright implications. Other issues, such as privacy rights (See 2.F.4-8), FOIA (see 2.D.4), and statutorily protected categories of information under ARPA and other laws (see 2.E.1-6) may arise when providing access.</p> <p>Copyright consideration must be given when there are requests to publish field notes and unpublished manuscripts. See 2.C.13 and 2.C.19 for further guidance on responding to publication requests.</p> <p>A non-NPS investigator who completed work on NPS lands that did not require a permit or worked in related localities, may donate field notes, raw data, and unpublished manuscripts, providing that the donation fits the park’s Scope of Collection Statement. The donor may convey copyright with the donation. Check the Deed of Gift in the accession file to determine copyright implications.</p>
<p>4. <i>Does the NPS own the copyright of letters in the park collections?</i></p>	<p>Generally not. For letters that private citizens and other private entities write to the government or to other recipients, the author holds the copyright even though the letters are in the park collection and are owned and managed by the NPS. To publish, electronically distribute or exhibit these letters, you must determine if the letters are under copyright protection (a function of who produced or ‘created’ them), whether they were registered or published, and when. Then you must find the copyright holder, and obtain written permission to use these letters. See C.12.</p>
<p>5. <i>How do I respond to a request for access to photos and other archival items that don’t have any associated information or rights transfer documents?</i></p>	<p>A request to have <i>access</i> to materials such as photos and letters (versus use, such as copying or publishing the material), does not have copyright implications (see 2.C.19). Other issues, such as privacy rights (See 2.F.4-8), FOIA (see 2.D.4), and statutorily protected categories of information under ARPA and other laws (see 2.E.1-6) may arise when providing access.</p>
<p>6. <i>How do I respond to a request to publish or otherwise use photos, documents and other works that don’t have any associated information or rights transfer documents, that is, ‘orphaned works?’</i></p>	<p>Give careful attention to requests to <i>publish or otherwise use</i> materials that do not have any copyright or owner information. These materials are referred to as “<i>orphan works</i>.” They occur when the owner of a copyrighted work can’t be identified and located by someone who wants to use the work in a manner that requires the copyright owner’s permission. Even where NPS has made a reasonably diligent effort to find the owner, if the owner is not found, NPS faces uncertainty. The NPS cannot determine whether or under what conditions the owner would permit use. Where the proposed use goes beyond an exemption or limitation to copyright, NPS cannot reduce the risk of copyright liability for such use, because there is</p>

	<p>always a possibility, however remote, that a copyright owner could bring an infringement action after that use has begun.</p> <p>The issue of orphan works and how to provide some certainty for their use is currently under consideration by the Copyright Office and Congress. Meanwhile, orphan works may be used in limited circumstances if the risk of infringement appears unlikely.</p> <p>Fair use considerations apply to orphan works (See 2.C. 15-16). Also, for dated works that were created before the effective date of the Copyright Act of 1976, a risk analysis regarding the duration of copyright, in consultation with the regional curator, regional solicitor, or the Park Museum Management Program and the Solicitor’s Office, can be done to determine whether use might be appropriate.</p>
<p>7. <i>How do I respond to a publication request for access to photos, letters, and other materials, in the collections where there are names but no rights transfers documents?</i></p>	<p>Treat a third party request to access materials for which NPS has ownership and background information as discussed above. The same access considerations, such as FOIA, privacy considerations and other laws governing access apply.</p> <p>When a request involves copyright concerns, grant a third party permission to publish or otherwise use materials that have limited information regarding potential ownership only after NPS has made an effort to determine its own rights in the material (see 2.C.10-13, 19 for further guidance).</p>
<p>8. <i>Are park collections considered ‘public domain?’</i></p>	<p>Not all park collections are in the public domain. Some collections may be in the public domain because they were developed or created by federal employees or the copyright has expired. However, NPS may hold copyrighted works that are transferred to a park, therefore, many of the park collections have existing copyrights and are not in the public domain (see. 2. C. 25-26). Requests for access to or to publish collections that are in the public domain do not have copyright implications. However, other issues, such as privacy rights (See 2.F.4-8), FOIA (see 2.D.4), and statutorily protected categories of information under ARPA and other laws (see 2.E.1-6) may still exist.</p>
<p>9. <i>a. If a child inherits a parent’s photo collection, does the child have the right to transfer copyright?</i></p> <p><i>b. Do I need to get rights transferred if the original copyright owner is an institution such as a newspaper that is now defunct?</i></p>	<p>No. Transfer of copyright ownership from one generation to the next by will, or otherwise, creates another class of problems involving individual copyright owners. Some heirs are completely unaware of their rights. Rights may be fractionally distributed among a variety of heirs, some or all of which may be remote from each other, or the potential user. In many cases, it is difficult to access information about an author’s (creator) estate. The copyrights may have been transferred prior to the author’s death or they may have been a work for hire. To determine current copyright ownership, the child and involved parties should be contacted for more information. Photos taken before 1978 may still have copyright protection (see 2.C. 9).</p> <p>If the newspaper is no longer in business, the intellectual property rights will likely have been transferred elsewhere during the dissolution of the business, for example, to a business that acquired</p>

	<p>the newspaper. NPS will have to determine to whom or to what entity the rights were transferred before using the photos.</p>
<p>10. <i>How do I handle requests to film, videotape, record, or do photography that will be used for commercial purposes?</i></p>	<p>NPS permits commercial filming and still photography when it is consistent with the NPS mission and will not harm the resource or interfere with the visitor experience. <i>All</i> commercial filming activities taking place within a unit of the National Park system need a permit. Commercial filming includes capturing a moving image on film and video as well as still recordings. Still photographers require a permit when: 1) the activity takes place at location(s) during times when members of the public are allowed; or 2) the activity uses model(s), set(s), or prop(s) that are not a part of the location’s natural or cultural resources or administrative facilities; or 3) the park would incur additional administrative costs to monitor the activity.</p> <p>All commercial filming and still photography meeting the above requirements involving NPS museum collections require a permit. Refer to Chapter 6, Other Uses of Museum Collections.</p> <p>Potential permittees should contact the park administrative office to obtain information and a permit application. Requests by permittees to commercially film or photograph museum collections with copyrights, such as paintings, must be treated like any other requests to use or access museum collections. Before granting permission, NPS should ensure that there are no access restrictions and that NPS has appropriate copyrights and authority to grant permission.</p>
<p>11. <i>If the park has a historic photograph dating to the early 1900s, and there are identical prints held at other institutions, are the images ‘in the public domain’ and can the park make them available for publication?’</i></p>	<p>If the image was published prior to 1923, it is now in the public domain and not subject to copyright protection. The image may be made available for publication unless there are any privacy concerns. In general, privacy concerns protect living individuals that are identifiable in the image. (See 2.F.).</p>

B. Access and Use Legislation

1. *What laws affect the use*

The primary provisions that affect access and use of NPS museum

of museum collections?

collections and their associated documentation include the following, listed in alphabetical order:

- American Indian Religious Freedom Act of 1978 (42 USC section 1996)
- Archeological Resources Protection Act (16 USC 470 aa-mm)
- The Copyright Act of 1976 (17 USC 101-810, 1001-1010)
- Defamation, including slander and libel (state law)
- Developing Case Law
- Executive Order 13007—Indian Sacred Sites (May 24, 1996)
- Endangered Species Act of 1973 as amended (16 USC 1531-1543)
- Federal Cave Protection Act of 1988 (16 USC 4301-4309)
- Freedom of Information Act (FOIA)
- Publicity laws (state common or statutory law in almost half the states)
- Native American Graves Protection and Repatriation Act (25 USC 3001-3013)
- National Historic Preservation Act of 1966, as amended (16 USC 470-470t, 110)
- National Parks Omnibus Management Act of 1998 (16 USC 5901-5937)
- The Patent Act (35 USC 101-376)
- The Lanham Act (Trademarks) (15 USC 1051 - 1127)
- The Privacy Act (5 USC 552a) and state common or statutory privacy laws
- Obscenity and Pornography (state law as well as federal, including the Child Protection Act of 1984)
- Publicity laws (state common or statutory law in almost half the states)
- Preservation Act of 1966, as amended (16 USC 470-470t, 110)
National Historic

Further information on applicable legislation, including legal mandates for protecting, preserving, and documenting NPS museum collections, appears as Appendix A: Mandates and Standards for NPS Museum

Collections Management in the *Museum Handbook*, Parts I and II.

2. *How do I address questions involving legal issues?*

See the Access and Use Legal Action chart in Figure 2.1 as a guide for addressing various questions that may pose legal issues related to reference, publications and accessioning. Figure 2.1 describes the type of request in the first column, the applicable legislation in the second, and the suggested action by park staff in the third column. Also refer to MH-II for information on legal issues related to accessioning, deaccessioning and loans.

C. Copyright Laws

1. *What is copyright?*

The Copyright Act of 1976 grants creators (for example, authors, artists, photographers, and architects) exclusive rights to their creative work, from the moment the work is in fixed form. Copyrights relate to use. Copyrights are a bundle of rights given to creators, including the economic rights to:

- ***reproduce the work***
- ***distribute copies*** by sale, lease, rental, loan, or transfer of ownership (including the right to control the first public distribution or publication of the work)
- ***publicly perform the work*** by recital, playing, dancing, rendering the work in a public space or by a public transmission of images and sounds through technological means
- ***adapt and prepare derivative works from the original work***, including translations, art reproductions, spin-off products, images of the original work
- ***publicly display the work*** by showing more than a single copy of the work either directly or by means of a film, slide, television image or other device or process

The creator of a work may divide the rights to the work and transfer some or all of the rights to another at his or her discretion. The creator may give, sell, or license any right or rights (such as the right to prepare derivative works, such as posters or T-shirts) to another, while retaining other portions of the copyright. Copyright sales or transfers may be exclusive (all copyrights to Company X) or for a specific time or place (for example, a single edition of a book).

2. *What laws make up copyright?*

In the United States, the following laws and treaties govern copyright:

- United States Constitution (Article I, Section 8)
- Copyright Act of 1909
- Copyright Act of 1976

- International treaties:
 - Berne Convention for the Protection of Literary and Artistic Works

3. *What is covered by copyright?*

The Copyright Act of 1976 protects any original material in fixed form from the moment of creation, including:

- architectural designs, including drawings, plans, and structures
- archival and manuscript materials, including architectural plans, correspondence, graphic, oral histories, photos, and pictorial works
- audiovisual works
- computer software
- dramatic and literary works
- graphic and pictorial works
- motion pictures and videotaped works
- photographic works
- recorded or notated choreographic works and pantomime
- recorded or notated musical works and sound recordings
- sculptural works
- vessel hull designs

4. *Can a person copyright an idea or fact?*

No. Only the creator's unique, original expression (such as an author's words, an artist's painting, a photographer's image, object, or composition) is protected, *not* ideas, facts, or topics. Your photograph or words are protected, but other individuals can write about the same topic or photograph the same object. Copyright protects a unique work. The topic, scene, or scenario can't be copyrighted, only the particular work based upon the topic or scene. The original work must be in a fixed form.

5. *What is not protected by copyright?*

Copyright doesn't protect:

- copy images of works (including digital and photographic works) if the copies are slavish or lacking in originality (Bridgeman Art Library Ltd v. Corel Corporation 1999, 36 F. Supp. 2d 191 [SD NY 1999])
- works created by U.S. Government employees as part of an employee's official duties (See C.6 and 7 below for further guidance.)
- ideas or concepts (patents protect ideas or concepts)

- facts
- systems, procedures, or methods of operation
- common or standard works, such as:
 - height and weight charts
 - blank forms
- works with little creative authorship, such as
 - slogans and short phrases
 - names and titles
 - variations in typographic lettering, coloring, or ornamentation

6. *Why are federal employees' works not protected by copyright?*

Works produced by federal employees within the scope of their employment are *not* protected by copyright because the Copyright Act of 1976 specifically excludes this category of work from copyright protection. The federal government, however, may hold copyrights when such rights are transferred or assigned to the United States. Since federal government-produced works are *not* protected by copyright, this puts the works produced by federal employees within the scope of their employment in the public domain.

An image taken by the NPS employee is not entitled to copyright protection. However, that does not mean that it can be freely used or distributed. Any copyrights existing in the object that is the subject of the image need to be considered when that image is further used. NPS use of such an image for inventory/security or research purposes is likely considered fair use if NPS does not own the underlying copyright. Such an instance should be covered in a loan agreement. Refer to 2.15 for information on fair use.

When a work, such as a book, consists of chapters or figures by both federal and non-federal creators (artists, authors, or photographers, for example), place a notice in the introduction indicating what portion (particular chapters, pages, and figures) of the work is covered by copyright protection. A notice might look like the following sample:

Copyright 1999, Susan Smith, Copyright claimed in chapters 5-7 and figures 5-1 through 7-30, exclusive of U.S. Government forms D-93 and D-333.

The notice assists researchers who want to obtain permission to use the work. *Note:* If, on their own time, federal employees create original works that have no relationship to their duties, the employees may copyright the works. If the works in question are related to their federal duties, the employees should obtain clearance, preferably in writing, from their NPS ethics officer before publishing and copyrighting the works.

7. *Are the works of federal contractors, cooperators, partners, and volunteers protected by copyright?*

Generally, yes. Copyrights created by contractors, cooperators, partners and volunteers do not automatically belong to NPS, even if NPS is paying for the work. If you hire independent contractors or work with cooperators, volunteers, and partners who create source material (such as a publication, painting, or World Wide Web home pages), the works they create may be eligible for copyright protection. Therefore, *always execute a written contract, license, cooperative agreement, or other agreement that governs issues of copyright ownership and use of the work before the contractor or cooperator begins work.* See Figure 3.6 for a sample. *Have the agreement expressly state that the individual's work is a 'work-for-hire' and all copyrights belong to the National Park Service.* In a work-for-hire situation, the employer becomes the *de facto* creator in the eyes of the law. Thus the creator/employer owns the copyrights. If, for any reason the contractor's work is deemed not to be a work-for-hire, your contract should stipulate that the contractor transfers any and all rights that he or she might have to the NPS.

Ensure that all your federal contracts, cooperative agreements, memorandums of understanding, volunteer-in-park, and similar agreements state that all copyrighted works and the copyrights of those works created as part of the contract belong to the National Park Service. Otherwise you may find that you are legally obligated to pay a royalty to the contractor, cooperator, partner, or volunteer each time you use the materials, as they will own the copyrights.

8. *When do copyright protections become active?*

Under the Copyright Act of 1976, copyright protection becomes active the moment an item is placed in fixed form; for example, when a photographic negative is made, a digital image created, a document written, or a charcoal drawing first sketched.

For works published in the U.S. after March 1, 1989, copyright notice (the symbol ©, the author's name, and date) is not required for copyright protection. For works published prior to March 1, 1989, a copyright notice is required to preserve the copyright in the work.

9. *What is the duration of copyright protection?*

The duration of copyright protection in the U.S. depends on when the work was first created or published. The chart below summarizes the duration periods.

<i>“When Works Pass into the Public Domain”</i> [by Laura N. Gasaway]		
Date of Work	Protected From	Term of Protection
Created January 1, 1978, or after	The time the work first is fixed in a tangible medium of expression	Life of the creator plus 70 years (or, if work is made for hire or anonymous or pseudonymous, 95

		years from publication, or 120 years from creation, whichever is shorter).
Published prior to 1923	The time it was first published with a copyright notice	None. Now in the public domain.
Published 1923 - 1963	The time it was first published with a copyright notice	28 years protection for the first term, plus could be renewed for 47 years; in 1998 it was extended to 67 years for a total coverage of 95 years if renewed. If not renewed, it is now in the public domain.
Published between 1964 and 1977	The time it was first published with a copyright notice	95 years from publication.
Created before January 1, 1978, but not published	January 1, 1978, the effective date of the 1976 Act	Life of the creator plus 70 years, or if the author's death date is unknown 120 years from date of creation. If work was unpublished as of 12/31/02, the work is in the public domain.
Created before January 1, 1978, but published between then and December 31, 2002	January 1, 1978, the effective date of the Act	Life of the creator plus 70 years or 12/31/2047, whichever is greater.

Note: The above chart was adapted from a chart prepared in December 1996 (updated November 4, 2003) by Laura N. Gasaway. (See <http://www.unc.edu/~unc1ng/public-d.htm>.) The actual legal date of publication may be hard to determine in some cases. Consult the regional curator or NPS solicitor through the Park Museum Management Program, if you have questions.

Additional considerations:

Works created before January 1, 1978	<ul style="list-style-type: none"> • If a work was published either anonymously or without a copyright symbol before January 1, 1978 or was published before 1923 or had a single term of copyright protection (28 years) before 1963 with no renewal, the work is likely to be in the public domain. Note: There is an exception for foreign works, which may have copyright restored after it lapses. Consult the Solicitor's Office to determine the copyright duration of a foreign work. • If the work is unpublished and was not registered for copyright protection with the U.S. Copyright Office, but created before January 1, 1978, the work is protected for the life of the creator, plus 70 years. If the work is anonymous or pseudonymous or a work made for hire, it is protected for 120 years from the date of creation. A work that remained unpublished as of 12/31/02 is in the public domain. • If the work is published for the first time before December 31, 2002, the term of protection will not
--------------------------------------	---

	<p>expire before the life of the author plus 70 years or December 31, 2047, whichever is greater.</p> <p>You can check with the Copyright Office of the Library of Congress to see when the copyright expires, if the work was published before January 1, 1978. Usually the coverage was 28 years from the date filed, with one renewal possible.</p>
Works produced on or after January 1, 1978	<ul style="list-style-type: none"> • General copyright protection for works produced after January 1, 1978, endures for the life of the author plus 70 years. • Duration for joint works produced after January 1, 1978, is measured from the death of the last surviving author plus 70 years. • Anonymous works, pseudonymous works, and works made-for-hire produced after January 1, 1978, are protected for the greater of 95 years from first publication or 120 years from creation.
Works published before March 1, 1989	<p>Works published before March 1, 1989, must contain a notice of copyright to be protected. Copyright notices usually consisted of the symbol © (or the word "copyright" or "copr."), the creator's name, and the date. Certain exceptions exist for foreign works.</p>
Works published on or after March 1, 1989	<p>Works published on or after March 1, 1989, do not require the notice, although most have it. Posting a notice gives the copyright holder certain additional benefits in the case of lawsuits if the work's copyright is infringed.</p>

For more information on copyright duration, request Copyright Circulars 15, 15a, and 15t from the Registrar of Copyrights, Copyright Office, Library of Congress, Washington, DC 20559-6000, or call the hotline at (202) 707-9100.

10. *When do I need to get copyright permissions?*

Get all necessary permissions *before* using or authorizing the use of the material in publications, exhibits, performances, through reproductions, or in derivative works.

There is a limited exception for exhibitions. If NPS owns a copy, including an original copy, lawfully made under the Copyright Act, it is entitled to display that copy publicly, either directly or by projection of no more than one image at a time, to viewers present at the place where the copy is located. This exhibition exception does not apply to putting digital images on the web.

“Publication” includes offering to distribute copies of a work to the public for purposes of written publication, public performance, exhibition, or further

distribution. Public distribution or the offer to distribute is key to determining if publication has occurred.

While a single exhibition or display may not be considered a 'publication,' the right to display a copyrighted work is protected, and displaying the work, except under the exception mentioned above, requires permission from the copyright owner. Make sure you obtain the rights to exhibit or display collections in the appropriate accession documents.

Derivative works are alternative or variant versions of a work based upon an original piece such as:

- postcards made from graphic or photomechanical prints, photographs, or paintings
- posters made from original photographs
- art work based closely upon existing original photographs or other art work
- exhibition captions that quote or paraphrase existing work

If you are asked to grant permission before you are certain of the legal status of the work *and* you want to do so, agree only to grant those rights that the NPS has, not all rights.

11. *What information do I need in order to obtain permission from the copyright owner?*

If you want to use, display, exhibit, publish or distribute work protected by copyright that is not held by NPS, you *must* obtain the permission of the copyright owner, unless there is a reasonable basis for considering the use a fair use. Discover as much information as you can:

- Was the work created by a federal employee within the scope of his or her employment or by a federal contractor? If a contractor was the creator, what did his or her contract state about copyrights?
- Does your accession document specifically state that you received all copyrights? If not, revisit and update the accession folder in accordance with guidelines outlined in MH-II, Chapter 2, Accessioning.
- Who created the work and is the creator alive? If not, when did the creator die?

Generally, copyright lasts for the life of the creator, plus 70 years. Copyright belongs to the heirs of the creator for 70 years after the creator's death unless the creator has transferred it to another.

- Is it a joint work created by two or more authors?

If so, it is protected for 70 years from the death of the last surviving author. You need to determine which authors are living.

12. *If the park owns the material physically, does*

No, not necessarily. Physical ownership or possession of materials is *not* an indicator of ownership of corresponding copyrights. Check the

it also own the copyrights?

accession document to see which of the following your park acquired:

- Transfer of all rights, including copyrights and/or literary rights to the park, made in writing You should obtain all rights, including all copyrights, for the park when you acquire materials for the museum collections. See MH-II, Chapter 2, Accessioning.
- written permission by the creator or his or her heirs to use the materials in limited circumstances for certain purposes
- no copyrights, as nothing was written about copyright in the accession document

If you must know a work's copyright status for a NPS project, you must research it. Since copyright notice and registration aren't required for protection of unpublished works, you can't simply assume that works without a copyright notice are unprotected. Works are now protected from the moment the creator's pen is lifted from the finished work. Writing the U.S. Copyright Office may not be sufficient to establish the copyright status of collections of paintings, sculpture, photographs, personal papers, assembled manuscript collections, and similar materials created outside federal agencies.

For example, the copyrights to all letters written to the NPS by a private citizen are held by that private citizen, even though the documents are owned and managed by the NPS. To obtain permission to publish, electronically distribute, or exhibit these letters, you must determine if the letters are under copyright protection (a function of who produced them, whether they were registered or published, and when), find the copyright holder, and obtain written permission to use the letters. For further guidance on determining copyright ownership and duration, see Question 13, 'If the park doesn't own the copyright, but I want to use the materials in a publication, what do I do?' below.

13. *If the park doesn't own the copyright, but I want to use the materials in a publication, what do I do?*

Regardless of whether the request is from park staff or from outside requestors, if you have no copyright or only limited permission to use the material, or if you doubt the person who granted you the copyright actually had it (for example, if the donor was not the creator or his or her heirs):

- You must *not* publish the work or grant permission to publish the work without obtaining permission, a usage license, or copyright first. Publication is the distribution of copies of a work to the public by:
 - selling or transferring ownership
 - renting
 - leasing
 - lending

- sharing freely without charge or restrictions

If all rights are not transferred to NPS as part of an acquisition, avoid future copyright issues by ensuring that the source of accession signs a statement on the accession form giving the park the unrestricted right to exhibit, publish in an exhibit catalog, do publicity, or use the item for other park purposes. Refer to MH-II, Chapter 2, Accessioning and A.3.5. on orphaned works.

- Generally speaking, for third party requests, it is the researcher's responsibility to obtain permissions and rights. It is not your responsibility to tell the researcher how to do this, as you are not a lawyer. If appropriate, you may provide the researcher with source of accession information, **if** the source is the copyright holder, which allows him to pursue permission. Make sure not to provide information that may compromise the source of accession's privacy. Consult with your regional curator should this situation arise.
- If you want to determine the copyright status of a work, you should do the following:
 - Find out if and when the creator died.
 - Find out who owns the copyrights if they are still active (usually the creator or his or her heirs).
 - If you are accessioning a copyrighted work, if appropriate, have the copyright owner or his/her heir sign the gift form or statement noting that he/she is the heir, owns the copyrights, and transfers copyrights to the NPS.
 - Make a good faith attempt to track down the creator, his or her heirs, or any known copyright holder. (Cumulative international telephone directories on the Internet can help your search.)
 - Document your attempts to track down these individuals.

Request permission in writing to use the work when you locate the copyright holder. See Figure 3.5 for a sample use agreement. Additional information is contained in the U.S. Copyright Office publication entitled "How to Investigate the Copyright Status of a Work." at <http://www.copyright.gov/circs/circ22.html>.

- Once you find the copyright holder, explain why the material has value to your park and request, in writing, **all** copyrights.
- If the creator or his or her heirs won't grant you all copyrights, consider asking for a license or permission to use the materials for special purposes, such as on the Web, in park publications and exhibitions, and for scholarly external use. Be specific. Refer to the wording in the sample licensing agreement, Figure 2.2.

- If you cannot find the copyright holder, and you are aware that copyrights exist, you cannot publish the work or grant permission to publish the work. If no information regarding copyright or the owner of the work is available, the work may be considered an orphan work. See FAQ #6 for further guidance.

14. *Can copyright be restored once it has lapsed?*

Yes. Despite the combined resistance to such legislation by archivists, librarians, and curators, several recent trade agreements have provisions for restoring copyrights for some motion pictures and sound recordings.

- The North American Free Trade Agreement Implementation Act provided copyright restoration for certain motion pictures created or published in Mexico or Canada if they entered the public domain in the U.S. because they were published between January 1, 1978, and March 1, 1989, without a required copyright notice.
- The Uruguay Round Agreements Act (17 USC 104a and 109) restores some foreign copyrights in foreign work in the public domain in the U.S., including art, literature, and sound recordings fixed before February 15, 1972, if the works were protected in their source country on January 1, 1996.

More such copyright restoration legislation may be in the works. Read your professional journals and newspapers or watch the legal Web sites listed in the bibliography for updates.

15. *What is fair use?*

Fair use is a defense to a claim of copyright infringement. Under the Copyright Act, certain “fair” uses of a work do not require permission of the copyright owner if the use is limited, primarily noncommercial, and in the context of:

- teaching
- private study, scholarship, or research
- satire, parody, commentary, and criticism
- news reporting

You may always copy or adaptively reuse facts and ideas, but NOT the specific words in which they were expressed.

16. *What criteria determine fair use?*

Don't assume that simply because a proposed use is non-profit, educational, scholarly, for news reporting or purposes of satire or parody that it is automatically a fair use. Fair use is subject to a case-by-case analysis of the four factors listed below:

- ***The purpose and character of the use:*** To be judged fair use, a usage should be a "transformative" use that adds value to the work. Works that add significant new commentary, contextualization, or content to the work are more apt to be judged fair than would be a

simple quote. Generally, uses for personal research, criticism, satire, parody, or news reporting are more likely to be judged as fair uses.

Commercial uses are less likely to be judged fair, while nonprofit usage is more likely to be judged fair. Commercial means that money was made using the material in question, even if the institution that made the money was a non-profit.

Commentary is a fair use, while a quote may not be. Substantial quotes are frowned upon, particularly in a commercial setting. Simply stating that you are quoting the item for news reporting purposes when you substantially quote a work does not excuse or authorize your use. You must offer transformative commentary or report on the material, which adds value to the work.

- ***The nature of the copyrighted work:*** Is the work fact or fiction? Is the work published or unpublished? You may quote facts and concepts, but *not* particular wording, except for fair use purposes (such as commentary, parody, satire, criticism, news reporting, teaching, private study, scholarship, or research). All usages of creative, dramatic, or fictional works are more likely to be judged infringements than are non-fictional or conceptual quotes.

The courts generally grant creators the right to control the first publication of their work, so infringements of unpublished materials tend to be dealt with more harshly if they involve a first publication situation by someone other than the creator or the creator's heirs.

- ***The amount and significance of the portion of the work to be used:*** Fair use is based upon the amount of the work being copied *and* the significance of the portion being copied in relation to the entire work. Using a whole work or the most significant section of a work is frowned upon. There is no pre-set amount or percentage of an item that is always okay to publish. Copying five relatively insignificant pages of a 75-page document may be judged acceptable, while copying the single most significant page may not. One page letters or photographs clearly shouldn't be used in their entirety.

Close paraphrasing of part or all of a document and other forms of plagiarism violate copyright protection unless you are simply repeating facts.

- ***The relationship of the item's use to the market for the item:*** Might the use affect the current or future market for the item? If a usage affects sales, to what extent are sales affected?

If you begin distributing copies to people who normally buy the item, you are having a negative effect. A ranger may be allowed to copy a page of a publication for a free park course for staff as that will have a minimal effect on the future demand for the item. Usages that serve

as equivalents to the original item in the marketplace (also known as market substitutes) are generally not judged to be fair usage.

A commercial training organization's use of the same material repeatedly in a profit-making course may be judged an unacceptable use. It doesn't matter if the item is currently out-of-print, rare, or still being sold on the newsstand, copying may be viewed as affecting an existing or potential market for the work. The extent of the effect must be determined.

17. *How does the fair use exemption impact me?*

When you attempt to apply copyright law, it may seem ambiguous. If you are uncertain about whether your proposed use is a fair use, obtain permission from the copyright holder or don't use the item. Practically speaking, uses that don't affect the market for the work and which use a small portion of a work, are the least likely to have problems in court. Request help from the regional curator or WASO NPS solicitor if you have questions.

Case law determines how a balance is struck between the rights of the creator and the needs of the user. See the bibliography Web resource list, particularly FindLaw's site at <<http://www.findlaw.com/casecode/>>, for guidance on how to track appropriate case law developments.

A recent case addressed whether fair use applied to the widespread photocopying of journal articles by scientists engaged in research on behalf of their employer, a private corporation that subscribed to the journal for the scientists' use. The corporation did not obtain permission or pay additional compensation to the publisher of the journal for the photocopies.

The court held that such photocopying was *not* a fair use and infringed on the copyright held by the publisher of the journal. *American Geophysical Union v. Texaco Inc.*, 60 F.3d 913 (2nd Cir. 1994). This interpretation of fair use has ramifications for those in NPS who wish to reproduce materials subject to copyright for internal agency use, whether in electronic or print form, without the permission of, and possible compensation to, copyright owners. If you are not sure, obtain permission from the copyright holder or don't use the materials.

18. *Are there additional copyright exemptions besides fair use?*

Yes. The library/archival provision of the law (under section 108 of the Copyright Act of 1976) has several exemptions that allow archives and libraries to make copies of a copyrighted work in limited circumstances. NPS archival collections fall under this exemption. ***However, note that this exemption currently does not apply to museums. The Copyright Office is considering whether museums should be included.***

The section 108 exemptions include the following provisions:

1. The right to reproduce and distribute three copies or phonorecords of an **unpublished work** duplicated solely for purposes of preservation and security or for deposit for research use in another library or archives if:
 - (a) the copy or phonorecord reproduced is currently in the collections of the library or archives; and
 - (b) any such copy or phonorecord that is reproduced in digital format is not otherwise distributed in that format and is not made available to the

public in that format outside the premises of the library or archives.

2. The right to reproduce three copies or phonorecords of a **published work** duplicated solely for the purpose of replacement of a copy or phonorecord that is damaged, deteriorating, lost, or stolen, or if the existing format in which the work is stored has become obsolete, if:

(a) the library or archives has, after a reasonable effort, determined that an unused replacement cannot be obtained at a fair price; and

(b) any such copy or phonorecord that is reproduced in digital format is not made available to the public in that format outside the premises of the library or archives in lawful possession of such copy.

A format shall be considered obsolete if the machine or device necessary to render perceptible a work stored in that format is no longer manufactured or is no longer reasonably available in the commercial marketplace.

3. The right to reproduce and distribute a single copy, made from the collection of a library or archives, where the user (including other libraries/archives) makes his request of no more than one article or other contribution to a copyrighted collection or periodical issue, or to a copy or phonorecord of a small part of any other copyrighted work, as long as the copy is used for purposes of study, scholarship or research, and a copyright notice is included with the provided copy.

4. The right to reproduce and distribute a single copy of the entire work, or a substantial part of it, if the library or archives has first determined, on the basis of a reasonable investigation, that a copy of the work cannot be obtained at a fair price, as long as the copy is used for purposes of study, scholarship or research, and a copyright notice is included with the provided copy.

Audiovisual, film, graphic, pictorial, musical, and sculptural works are not covered under this exemption and should NOT be copied under this provision of the copyright law. This limitation does not apply to (1) or (2) above, nor does it apply to pictorial or graphic works contained within works described in (3) and (4) above.

Up to three preservation copies in digital or analog form may be made of textual works when:

- the library or archives already has an original copy of the work (even if the original copy has been lost or stolen)
- the copy is solely for preservation, security, or deposit in another library
- the copy will be available only in the archives or library, not outside the archives or library. *Note:* There is one exception to this rule. Copies may be made for deposit in another library for purposes of preservation or security
- the format of the original has become obsolete, such as if equipment or devices necessary to play it are no longer manufactured or

commercially available

When libraries and archives want to copy works without infringing copyright, according to Section 108 of the Copyright Act, the institutions must:

- be open to the public without restrictions or to a specified portion of the public, such as a group of researchers on a particular topic
- not provide the copy for commercial purposes or for distribution outside of the premises of the repository other than for face-to-face teaching activities within a classroom
- include a copyright notice on or with the copies provided or a clear statement about the applicability of copyright to the work

19. *What should I do if I'm uncertain of the copyright status of a work and the fair use quality of a reference request?*

Copyright is a use, not an access, restriction. Subject to privacy or other applicable laws, anyone may look at the material at any time for research, study, private scholarship, satire, parody, criticism, and news reporting. Copyright law allows limited copying of small portions of copyrighted materials *for non-commercial purposes, if the copying qualifies as fair use*. Copyright also allows copying for security, preservation, and deposit in another institution.

So, if you are uncertain of the copyright status of a work, don't grant permission to:

- publish
- distribute
- reproduce
- produce derivative works from the original item.

Never authorize public distribution, public performance, public display of multiple copies, or alterations or production of derivative works or publication in writing unless you are absolutely certain that:

- you have the copyrights, *or*
- the copyrights have expired, *or*
- the copyrights never existed (as with government works), *or* the copyright holder has granted you a written license or permission to use the work, the terms of which allow you to grant permissions to others.

Tell the requester he is responsible for obtaining the rights and permissions from the copyright holder, which is not necessarily the NPS. You may inform the requester that he may make a FOIA request for the source of accession information to pursue permission

You should also:

- Ask the requester to sign an NPS researcher registration and duplication form and a copyright and privacy restrictions statement. See *MH-II*, Appendix D, Museum Archives and Manuscript Collections, Figures D.14-D.16 and the ANCS+ User Manual.
- Inform the requester that by signing the copyright and privacy restrictions form, he or she has indemnified your park.
- Place a warning concerning copyright restrictions in your research room on your own copy machine that states:

The copyright law of the United States (Title 17, United States Code) governs the making of photocopies or other reproductions of copyrighted material. Under certain conditions specified in the law, libraries and archives are authorized to furnish a photocopy or other reproduction. One of these specified conditions is that the photocopy or reproduction is not to be "used for any purpose other than private study, scholarship, or research." If a user makes a request for, or later uses, a photocopy or reproduction for purposes in excess of "fair use," that user may be liable for copyright infringement. This institution reserves the right to refuse to accept a copying order if, in its judgment, fulfillment of the order would involve violation of copyright law.

Contact the regional curator or the NPS solicitor through the Park Museum Management Program, if you have copyright questions.

20. *Is fair use different in a networked electronic environment?*

Although the concept of fair use is the same, applying it may be quite different. In addition, legislation and case law are only beginning to catch up with recent changes in technology. The Digital Millennium Copyright Act (DMCA) has addressed copyright issues involving newer forms of technology. The DMCA exempts online service providers from some copyright infringement claims, prohibits removal of identifying information from copyrighted works, prohibits technological removal or circumvention of devices designed to protect copyrights, and allows archives and libraries to make digital copies for archival purposes. See Section C.11 for how to legally use digital media for preservation.

In *Kelly v. Arriba Soft Corp.*, 336 F.3d 811 (9th Cir. 2003), the court held that a search engine's creation of small reproductions ("thumbnails") of images and placing them on its own website did not diminish the potential market for the sale or licensing of those images. The court reasoned that the thumbnails were much smaller and of much poorer quality than the original photos and provided an index of the images to facilitate public access to them. However, original creative electronic materials are protected by copyright. If you copy something electronically that doesn't meet the fair use criteria described in Question 10, it may constitute copyright infringement.

Because copyright issues in the electronic networked environment, such as

the examples discussed above and below, are relatively recent and just starting to be addressed by the courts, contact your regional curator or the NPS solicitor with any questions involving these areas.

Some examples of potential electronic infringements include:

- ***Quoting another person's message in its entirety in the body of your e-mail message:*** Instead, state in a summary sentence what the discussion was about.

In some contexts, such as commenting on the original message in the original electronic location, this may be an implied license (see below), because reasonable people expect comment on the information they post on public bulletin boards. Sending the quoted message to another electronic bulletin board, however, may be an infringement.

Messages produced by government employees during the scope of their work are not copyrighted. Such federally produced work is in the public domain. Many of the federally produced messages on government bulletin boards may be quoted or reproduced in their entirety without reservation.

Don't reproduce messages by non-federal correspondents in their entirety in your message or forward them to other bulletin boards without permission of the creator. Significant quotes from non-federal correspondents' messages should be done with discretion, and only when there is an implied license (see below). The legality of such unapproved uses is decided on a case-by-case basis.

- ***Downloading a Web publication and forwarding it to a bulletin board or newsgroup:*** Instead, post the uniform resource locator (URL) or Internet address. Downloading a copyright protected publication onto a permanent storage device (server, disk, or tape) is an infringement of the right to reproduction.
- ***Maintaining an online Web site of material pulled from other Web sites without obtaining a license or permission to use the material:*** Instead, list URLs, link to the existing materials, or obtain permission to use the material. This is an infringement of the copyright holder's right of reproduction.
- ***Modifying an image taken from another source and loading it onto a permanent storage device (such as a disk, hard drive, or server) infringes the copyright holder's rights of reproduction, distribution, and adaptation (or derivative rights).*** If the work dates from after June 1, 1991, and is visual art, the usage may also infringe the copyright holder's moral rights under the Visual Artist's Rights Act.
- ***Using the concept of implied license to authorize publication and distribution:*** The concept of implied license is often used to justify certain kinds of publications that don't fall under fair use. Implied license is when a creator (who holds copyright) acts in such a way

that you, as a reasonable individual, would assume you have permission to publish the piece. An example is when an individual writes a letter to the editor of a newspaper. It has been normal practice for newspapers to publish these letters without seeking additional permission. Since most of the world knows about this practice, sending a letter to the editor grants implied license. The implied license would not extend to those using such a letter in an archive. Only the newspaper received the implied license, based on the use the newspaper and the author intended.

Implied license doesn't justify new activities in the electronic realm, such as forwarding e-mail messages to individuals other than those to whom the creator sent the piece, copying messages from one electronic bulletin board and posting them on another, or similar activities. Apply the concept of implied license cautiously. Just because your site is secure and password-protected doesn't make copying of materials without permission a fair use. Even on a secured site you still need permission to use copyrighted materials. If you have questions, contact your regional curator or the NPS solicitor.

- ***Removing a “technological control”*** such as encryption used to protect copyrighted works or attached intellectual property rights management information from a file's metadata is a violation under the Digital Millennium Copyright Act (DMCA) for purposes other than fair use
- ***Removing the name of author(s) from a work***, is a violation under the DMCA and may be an infringement under the Visual Artist's Rights Act, if the work was created after June 1, 1991.
- ***Deep linking (that is linking to a lower level of a web site rather than the site's home page)*** may also pose problems as the creator/author's credit may be obscured, or the site content may change to potentially offensive material. Avoid links that avoid providing credit to the linked site's creators and sponsors. The Visual Artist's Rights Act partially protects these works. Follow the NPS policy on linking (DO 70, Internet and Intranet Publishing).
- ***Linking to another site without permission so that the link implies a connection, endorsement, or authorization*** that doesn't exist. Refer to Director's Order 70, Internet and Intranet Publishing at <http://data2.itc.nps.gov/npspolicy/DOrders.cfm>.
- ***Framing another Web site's text via the use of a border, window, or frame must be done only when you have that Web site creator's permission*** in writing. Generally you must keep the original credit line, captions, and intellectual property rights management information on the site or you will be infringing the Web site creator's rights to adapt or produce derivative works.

21. *Why and when must I place copyright notices on*

Although original works don't require a copyright notice to be protected, notices serve as an excellent warning when materials are protected,

copies and copiers?

particularly for copies. Such notices can protect archives, libraries, and museums from lawsuits. By law, copies provided for fair use purposes or under the library/archives exemption **MUST** be marked with a copyright statement. Each copy should carry one of the following notices:

- **If the original work already has a copyright notice**, place the following statement on the copy: “The work from which this copy was made included the following copyright notice: ‘[transcribe the original notice and place it here].’”
- **If the original work has no copyright notice**, place the following notice on the copy as a rubberstamp, typed transcription, or other marking: “The work from which this copy was made did not include a formal copyright notice. This work may be protected by U.S. copyright law (Title 17, U.S. Code), which governs reproduction, distribution, public display, and other uses of protected works. Uses may be allowed with permission from the copyright holder, or if the copyright on the work has expired, or if the use is “fair use” or within another exemption. The user of this work is responsible for compliance with the law.”
- Copiers and copy order desks should have the following notice posted:

“The copyright law of the United States (Title 17, United States Code) governs the making of photocopies or other reproductions of copyrighted material. Under certain conditions specified in the law, libraries and archives are authorized to furnish a photocopy or other reproduction. One of these specific conditions is that the photocopy or reproduction is not to be ‘used for any purpose other than private study, scholarship, or research.’ If a user makes a request for, or later uses, a photocopy or reproduction for purposes in excess of ‘fair use,’ that user may be liable for copyright infringement. This institution reserves the right to refuse a copying order if, in its judgment, fulfillment of the order would involve violation of copyright.”

- With regard to taking **photographs of original works of art**, such as paintings, you may consider posting a notice in the exhibit area that explains the NPS commercial filming and photography permit requirements. This notice could also remind visitors that copyrights may exist for some items on exhibit. However, NPS is not required to post such a notice since we aren’t providing the copies themselves or the means (such as a copy machine) to make copies.

For further guidance read *MH-II*, Appendix D, Museum Archives and Manuscript Collections, Section T, Providing Access to Archival and Manuscript Collections and Section U, Identifying Appropriate Restrictions for Archival and Manuscript Collections.

22. *How do I handle unpublished materials?*

Unpublished manuscripts, drawings, and other materials may still be subject to copyright protection.

Generally, unpublished materials created on or after January 1, 1978, are subject to copyright protection for the life of the creator plus 70 years. Copyrights for unpublished works made for hire or anonymous or pseudonymous works created on or after January 1, 1978, last 120 years from the date of creation.

Draft documents have the same potential for copyright protection as non-draft documents.

Copyright protection for unpublished materials created before 1978 lasts for the life of the author plus 70 years. However, if the work created before 1978 remained unpublished as of December 31, 2002, the copyright is expired.

If you wish to publish an unpublished work, get permission from the creator, copyright holder or his or her heirs. Contact the regional curator and the NPS solicitor for assistance on how to proceed.

23. *What is the public domain?*

Works are in the public domain if they have no copyright protections. This may occur for a variety of reasons. See 2.24, 'When is a work in the public domain?'

Note: Be cautious when assuming a work is in the public domain. In certain instances, works of foreign origin that once were in the public domain may have had their copyright protections extended.

24. *When is a work in the public domain?*

Work is in the public domain, available for general use without written permission or payment, when one of the following applies.

- It was created by federal employees as part of their official responsibilities. (Federal government work can't be copyrighted even though such work may appear occasionally in published volumes that are copyrighted. The federally produced portion of the material is not covered.)
- The copyright term has expired without renewal or restoration. See 2.9, 'What is the duration of copyright protection?'
- Copyright protection never existed, such as when a work was published before 1978 without a required notice of copyright.
- The work is ineligible for copyright protection, such as a work that consists solely of facts.
- The copyright owner relinquished all rights and effected an intent to place the work in the public domain.

25. *What is the right of "first sale?"*

The right of first sale is an exemption to the creator's copyright to sell a work. Any individual, who lawfully owns a copy of a work, has the right to "first sale" of the work. That is, a collector who has bought a work from a creator may sell or otherwise dispose of his or her lawful copy without permission from the creator who owns the copyright.

For example, if you purchased a copy of a poster, you may later resell or donate that poster to whomever you please without obtaining permission from the creator or other copyright holder. However, you may NOT duplicate, publicly distribute, perform, or exhibit multiples of that poster.

Most states (except California) don't require that a portion of revenues from sales of works automatically go to the original creator of the work if another owns the work being sold, such as a collector.

26. *What are visual artist's moral rights?*

Under Section 106(A) of the Copyright Law, artists and other creators of visual work (as defined by the statute) created after June 1, 1991, are given the additional "moral" rights of having:

- their works properly attributed (correct captions and credit lines)
- no works created by others (not the artist) wrongly attributed to the artist
- their works created after June 1, 1991, protected from destruction during the artist's lifetime
- the integrity of their works maintained (no destruction; no rearranging composition, color values, or picture elements)

D. Freedom of Information Act

1. *What is the Freedom of Information Act (5 USC 552)?*

The Freedom of Information Act (FOIA) provides citizens with information on their government's actions through access to the documentary records of those actions. State FOIA laws, which exist in many states, do the same for state records. FOIA governs what federal records, including federal records in NPS museum collections and materials under records management control must be made accessible by law.

2. *What are federal records?*

Records include all books, papers, maps, photographs, machine readable materials, or other documentary materials, regardless of physical form or characteristics, made or received by an agency of the United States Government under Federal law or in connection with the transaction of public business and preserved or appropriate for preservation by that agency or its legitimate successor as evidence of the organization, functions, policies, decisions, procedures, operations or other activities of the Government or because of the informational value of the data in them. Excluded materials are extra copies of documents kept only for reference, stocks of publications and processed documents, and library or museum materials intended solely for reference or exhibit.(44 U.S.C. 3301)

3. *How does FOIA affect park museum collections?*

FOIA requires that NPS staff and other federal government agencies provide the public swift access to certain governmental records upon request, regardless of other priorities or the effect of sharing such information (with certain exemptions).

FOIA involves a quick response within 20 days to information requests that include:

- determining if the requested material exists
- locating the appropriate materials
- determining whether FOIA exemptions apply
- responding to the FOIA request within 20 days of receipt

4. *What must I provide under FOIA?*

In general, you must provide:

- any federal records already provided to outside users, such as the public, Congress, or the courts. Once provided, these materials are public records, available to all requesters
- any federal records, except those listed as exemptions in D.4.

Many organizations have found World Wide Web sites to be a cost-effective way of providing access to commonly requested information.

FOIA gives the public access rights to government records. FOIA doesn't apply to museum collections, other than federal records that are managed in museum collections (such as resource management records) and museum records.

Don't attempt to answer FOIA requests on your own. Refer all such requests, whether written or oral, to the superintendent, administrative officer, and designated park FOIA officer. You may be asked to collect response data or to draft a response for the Superintendent's signature. Information requested under FOIA on collection storage location, appraisal and insurance values, or the donor or lender's address will in most cases, be withheld. Before denying any FOIA request, consult the Solicitor's Office and the regional curator.

5. *What don't I have to provide under FOIA?*

You don't have to conduct original research to answer FOIA requests. Provide only existing records. You don't have to create records where none exist. Some federal records are legally exempt from FOIA requests. The FOIA exemptions include:

- matters of national defense, foreign policy, or intelligence (classified records)
- internal personnel rules and practices
- trade secrets, commercial, or financial information that might help a competitor
- privileged interagency or intra-agency memoranda or letters,

including pre-decisional and attorney-client privileged documents.

- personal information affecting an individual's privacy, such as medical, psychiatric, or employment records
- records compiled for law enforcement
- records of financial institutions
- geological and geophysical information concerning wells
- materials protected by other statutes, such as the Archeological Resources Protection Act, the National Historic Preservation Act, and the National Parks Omnibus Management Act of 1998, which allow withholding of information on the nature and location of certain resources

Confirm first with the regional curator, NPS solicitor, the affected park staff (for example, cultural or natural resource managers), the FOIA officer, the superintendent, and the regional public relations officer, the ability to withhold the following sensitive information before responding to a FOIA request for information noted below:

- location of nesting sites or other habitat information of threatened and endangered species, consistent with the Endangered Species Act (16 USC 1531 et seq.). See Section F, Question 14.
- museum collection storage location and appraisal and insurance values
- donor or lender addresses
- draft research and publications that haven't yet been completed, particularly scientific findings
- location information for archeological and paleontological sites
- information concerning the nature and specific location of a National Park System resource which is endangered, threatened, rare, or commercially valuable, of mineral or paleontological objects within units of the National Park System, or of objects of cultural patrimony within units of the National Park System

Information covered under these exemptions is only releasable under FOIA in limited circumstances, on a case-by-case basis. **If you get such a request, immediately contact the FOIA officer who may contact the NPS solicitor.**

The Executive Order on Sacred Sites is NOT a FOIA exemption. A FOIA request for information covered under this Executive Order should be brought to the attention of the NPS solicitor as other legislation such as the National Historic Preservation Act may apply.

6. *What do I do if I receive a FOIA request?*

Alert your superintendent, and then work with your park or FOIA officer to develop an immediate response. Be aware that the NPS solicitor must approve any denial of information that you make to a request. Removing a single word from a requested document (redacting text) is considered a denial, even though the deletion may be classified as an exemption. Provide the required documentation to the requester within 20 days, unless the request fits one of the exemptions listed above.

If you are unsure if you should fill the FOIA request, discuss this with the FOIA officer, the regional curator, and the regional public affairs officer immediately. A response letter stating that the application is under review must go out within 20 days of receipt of the request.

If the material requested originated with another federal agency or a non-federal entity, contact the FOIA office for special instructions.

E. Location Information

1. *How does the Archeological Resources Protection Act (ARPA) of 1979 (16 USC 470) affect use?*

ARPA defines archeological resources as material remains of human life or activities that are 100 or more years old and capable of supporting humanistic or scientific studies of past human behavior and cultural adaptation through the application of scientific or scholarly techniques. In particular, ARPA protects archeological resources and their location, including *sites, field records, Geographic Information Systems and Global Positioning System documentation, databases, maps, notes, documentation, and location-notated objects*— on public and Indian lands by:

- requiring that information on the location and nature of archeological resources remain confidential if disclosure might harm the resource
- requiring permits for studies
- establishing penalties for damage, excavation, or removal of resources without a permit
- requiring that resources excavated on public land have all resulting materials preserved with their associated records in a suitable repository
- giving the Secretary of the Interior authority to issue regulations for the proper curation of federally owned and managed archeological collections

2. *How does the National Historic Preservation Act of 1966, as amended (16 USC 470-470t, 110) affect use?*

In Section 304, the National Historic Preservation Act provides a requirement to:

"...withhold from disclosure to the public, information about the location, character, or ownership of a historic resource if the Secretary and the agency determine that disclosure may:

- (1) *cause a significant invasion of privacy*

(2) *risk harm to the historic resources; or*

(3) *impede the use of a traditional religious site by practitioners."*

The types of information that can be withheld according to a written opinion by Jerry Rogers, NPS Associate Director of Cultural Resources, in an October 18, 1993, letter to F. Dale Robertson, Chief of the U.S. Forest Service, includes:

- location information that identifies where a historic property was constructed or where a historic event occurred
- character information, such as the combination of qualities or features that make a resource significant, for example archeological artifacts or architectural ornamentation, which could attract theft or vandalism
- private ownership information, such as the owner's address

Don't attempt to answer FOIA requests on your own. Refer all such requests, whether written or oral, to the superintendent, administrative officer, and designated park FOIA officer. You may be asked to collect response data or to draft a response for the Superintendent's signature.

Information requested under FOIA on collection storage location, appraisal and insurance values, or the donor or lender's address will in most cases, be withheld. Before denying any FOIA request, consult the Solicitor's Office and the regional curator.

If you receive a request for information that is protected under this law, first check with your superintendent, regional public relations officer, and FOIA officer and the NPS solicitor, then follow the FOIA denial procedures. Write to the requester within 20 days, indicating the request is being denied under the National Historic Act Preservation Amendment.

3. *How does the Executive Order 13007—Indian Sacred Sites (May 24, 1996) affect use?*

The Executive Order states that where appropriate, agencies shall maintain the confidentiality of sacred sites. However, where there is conflict regarding the release of information under FOIA, FOIA governs and supersedes the Executive Order. Consequently, site information confidentiality cannot be guaranteed under FOIA. However, site location and other information may be withholdable under ARPA, NHPA, NPOMA (see E.4) or other legislation. Bring FOIA requests for sacred site location information to the attention of the NPS solicitor, as well as the FOIA officer, the regional public relations officer, and SO staff.

4. *How does the Federal Cave Resources Protection Act of 1988 (16 USC 4301-4309) affect use?*

The Federal Cave Resources Protection Act states that federal cave location information may not be made available to the public unless the Secretary of the Department of the Interior determines that further disclosure would serve departmental purposes and *not* create a substantial risk of harm, theft, or destruction of the cave.

The DOI Secretary may make information available regarding significant caves upon written request by:

- federal and state government agencies
- bona fide educational institutions
- research institutions

If you receive a request for information you wish to protect under this law, such as federally-protected cave location information, first check with your superintendent, regional public relations officer, FOIA officer, and the NPS solicitor, then follow the FOIA denial procedures. Write to the requester within 20 days, indicating that the request is being denied.

5. *What do I need to know about the National Parks Omnibus Management Act of 1998 (P.L. 105-391)?*

The National Parks Omnibus Management Act of 1998 (NPOMA) addresses information in two ways. It establishes a research mandate to expand information on resources of the National Park System to benefit science and resource management and provides for control of that information to protect resources. The section on confidentiality of information states:

Confidentiality of Information. Information concerning the nature and specific location of a National Park System resource which is endangered, threatened, rare, or commercially valuable, of mineral, or paleontological objects within units of the National Park System, or of objects of cultural patrimony within units of the National Park System, may be withheld from the public in response to a request under section 552 of title 5, United States Code, unless the Secretary determines that (1) disclosure of the information would further the purposes of the unit of the National Park System in which the resource or object is located and would not create an unreasonable risk of harm, theft, or destruction of the resource or object, including the individual organic or inorganic specimens; and (2) disclosure is consistent with other applicable laws protecting the resource or object.

If you receive a request for information that falls under this category, such as the location or nature of mineral or paleontological specimens that are threatened, endangered, rare, or commercially valuable, you may restrict this information. Consult with your regional curator when receiving a request for this type of information.

You may also restrict access to objects of cultural patrimony and the information related to those objects. Objects of cultural patrimony may be any items which have been identified by the NPS as having importance for archeology, history, ethnography, literature, art, physical or natural sciences, or culturally affiliated groups. This definition includes, but may not be limited to, the definition of “objects of cultural patrimony” used in 25 USC Sect. 3001-3013 for certain objects associated with Native American groups or cultures.

If the request comes as a FOIA request, contact your park FOIA officer, as well as the park's natural resource manager, regional public relations officer, regional curator, the WASO threatened and endangered species coordinator, and the NPS solicitor. Work with these professionals to

discover if the request can be denied under the National Parks Omnibus Management Act of 1998 confidentiality provision. The FOIA officer will make the decision on a case-by-case basis. For information, see Chapter 1, Section F, Scientific Issues.

6. *What do I need to know about the Endangered Species Act of 1973 as amended (16 USC 1531-1543)?*

Location information on nesting sites or specific habitat of threatened, endangered, rare, or commercially valuable species is extremely sensitive. Restrict general access to this information. If you receive a FOIA request for this information, contact your park FOIA officer, regional curator, the WASO threatened and endangered species coordinator, and the NPS solicitor immediately to determine whether the information can be withheld under FOIA.

The FOIA officer makes the final decision. See Chapter 1, Section F, Scientific Issues.

7. *What do I need to know about protecting the location of paleontological sites?*

Location information on paleontological sites is protected by NPOMA described above. You should restrict access to this information to protect paleontological resources unless the park superintendent and paleontologist determine otherwise. Make these data available only after a careful review process.

If you receive a FOIA request, contact your park FOIA officer, the regional public relations officer, the park's paleontologist or natural resource manager, your regional curator, and the NPS solicitor immediately. See Chapter 1, Section F, Scientific Issues.

F. Privacy and Publicity Legislation

1. *How does privacy legislation affect park museum collections?*

Federal and state privacy laws protect living private individuals by giving them a legal right to be left alone without intrusion into their personal affairs. There are four components of privacy protection:

- Protection from public intrusion on a private living individual's personal or private life
- Protection from public disclosure of private, potentially embarrassing information, such as medical, legal, or counseling information
- Protection from the circulation of misleading information about a private living individual or the placing of true information about the private living individual in a misleading light that implies something that is not true about the individual
- Protection from the use or appropriation of a private living individual's name or likeness by another, particularly for gain

Privacy protections are not absolute and without limits. To be judged illegal, a usage must be distasteful, embarrassing, or objectionable to a person of normal sensibilities. Public figures are generally judged to have a lesser right to privacy protections as they have a lesser expectation of privacy. Unlike copyright, an individual's right to privacy ends at death.

The level of protection applicable to a situation may vary. Documentation of private living individuals produced when an individual has an expectation of privacy, such as in their own home, has a higher level of protection. Documentation of the same individual produced in a public arena might be treated differently by the courts. For example, a photograph taken while the same private person was walking in a public visitor center in a park, is generally somewhat less well protected (as the individual had a lesser expectation of privacy) than a similar image taken in a private locale (where the person had a greater expectation of privacy).

Some private information may be withheld under FOIA. However, where FOIA provisions and state privacy laws conflict, the FOIA provisions will govern.

Practically speaking, privacy legislation stops museums from publicly disclosing private data. Privacy legislation also limits how museum staff may provide access to certain documentation on private, living individuals including:

- medical and psychiatric records
- employment records
- legal records
- oral and video histories (transcripts and tapes) [unless a release authorizing NPS has been signed]
- photographs (including portraits, candid shots, and images of private residences)
- motion pictures (including amateur and professional footage, both posed and candid)
- video and audio tapes (including amateur and professional footage, both posed and candid)

To use materials that document private, living individuals, you need to obtain signed release forms or permission statements from the documented individuals. Releases and transfers of rights, including copyrights, should be obtained when material is accessioned into the museum collections. See Figure 3.6 and 3.7 for sample release documents. Obtain releases from both interviewees and interviewers *prior* to allowing access or publication. Without the release forms, your park may be subject to lawsuits for invasion of privacy.

Special areas of concern for privacy issues are:

- material that intrudes on one's seclusion or private affairs
- any material usage that publicly discloses private information

- material that places a person in a misleading or false light; for example, a published statement that implies an individual was wealthy, a spy, a police officer, or a criminal when the individual was none of those things
- any material that places a private individual in an embarrassing situation
- any material that contains nudity (whether of adults or children)
- any commercial usage of any private information

For all of these materials, the researcher will need to obtain permission to use these materials and information about the individual from the subject. Remember, fair use applies only to copyright and *not* to publicity and privacy claims

Your researcher duplication form should include an indemnification statement that the researcher must sign agreeing to pay all court and legal costs in case of a lawsuit. See *MH-II*, Appendix D, Figure D.14, Researcher Duplication Form.

As with copyright, the burden of obtaining the permission to use private information is on the researcher. You must notify the researcher in writing (such as on your researcher registration and duplication forms) that he or she is responsible for obtaining the necessary permissions from the individuals documented before the park can grant permission to publish. If the documented individuals refuse to grant permission, or the researcher is unable to locate them to obtain permission, don't grant permission to publish, distribute, or otherwise use the material until all private individuals documented in the materials are deceased.

2. *Who has little or no right to privacy?*

In general, the dead have no rights to privacy. However, in limited circumstances, privacy concerns may arise for the living relatives of the deceased individual. For example, personnel records might indicate psychiatric or medical histories that the family does not want to share with the public.

In many court cases, famous people have been judged to have less than full right to privacy, including:

- movie and TV stars
- famous singers and musicians
- well-known criminals
- other well-publicized individuals

In the case of famous individuals, it is wise to take a conservative approach to avoid lawsuits. Request permission to use materials that may be construed by the courts to be private from all living individuals, even if

the individual portrayed is famous.

3. *What is covered under the right to privacy?*

Generally, the right to privacy provided by state laws protects private, living individuals from intrusion, including:

- audio- and videotaping of their conversations
- photographing, filming, or taping of the person or home
- public disclosure of private information, such as:
 - medical and psychiatric history
 - personnel records and employment history
 - confidential lawyer-client and clergy-client discussions
 - information that embarrasses an individual, even though the information may be true
 - information that places a person in a false light or an untrue or misleading situation

Note: This is similar to defamation laws (also known as libel and slander laws); although in libel and slander laws the individual is protected only from the disclosure of information that is both false and willfully misleading. Unpleasant but true information may not be defamatory, although disclosure of that information may be an invasion of privacy, depending on the facts of the case.

- The right to privacy also includes freedom from having anyone else use any aspect of your persona or your information for gain, including your:
 - name
 - face
 - nude image (adult or children)
 - fingerprints
 - house (images)
 - private words

4. *May I provide private information for fair use, such as education and research?*

No. Privacy is an access as well as a use restriction. *In most states, the fair use clause does not allow access to private information.* Researchers may not have access to private information about other private, living individuals for the following reasons:

- The general public has no legal right to private information about individuals other than themselves.

- FOIA has a privacy restriction to ensure private information is not wrongly provided as the result of a FOIA request.

5. *How does privacy law affect museum or archival collections?*

Two broad categories of museum materials may pose privacy problems:

- oral and video history tapes and transcripts without signed release forms from all participants, including the interviewers and the interviewees
- photos, videotapes, digital files, and motion picture film footage without signed release forms from all individuals shown

Don't provide these materials unless you have signed release forms or permission statements from the individuals (interviewees and interviewers) documented in the tapes, transcripts, files, and other documents.

If you are involved in creating oral or video histories, you should get an oral release statement on the tape itself from both the interviewer and the interviewee at the start of the interview. Have a formal release signed by both parties once the tape has been recorded and transcribed and edited by the interviewee. Once the transcript is prepared have both the interviewer and the interviewee sign a separate release form for the transcript. Include a copy of the release form in the accession folder.

6. *How do I avoid rights problems when producing new products, such as photos?*

Have all private individuals who are taped, transcribed, filmed, or photographed sign a release form giving you all copyrights and written permission to use this material in any way you wish (also called a release form). See Chapter 3, Figures 3.6 and 3.7 for sample release forms

Documenting federal staff during work hours is generally considered part of the documented person's job. For example, videotaping interpretive rangers for training purposes may be considered part of their job.

Always have individuals who are being taped, filmed, photographed or transcribed, sign a release form.

If a private individual gives you permission to use material in one setting, such as an interpretive slide show, ***don't*** assume that you may use it in another setting, such as on the World Wide Web or in another publication, without getting additional permission. You must either have the individual sign a general release form, or receive written permission for each new type of use.

7. *How do I avoid privacy rights problems when using old photographs and related materials?*

Obtain written permission from the rights holder where possible. You or your researchers may need to obtain multiple permissions to use a single work within your collections in publications or exhibitions. If you do not know who the rights holder is and you want to use the work, consult the Solicitor's Office for advice regarding the level of legal risk associated with using the material.

The risk of violating the right of privacy is minimal in the case of a celebrity or public official because both seek public attention and

voluntarily live in the public eye. The right of privacy tends to relate more to private persons because they generally do not seek public attention. A private person may lose protection if the individual becomes the subject of newsworthy attention; this balances privacy interests with First Amendment concerns.

The risk of violating the right of privacy is also minimal with respect to deceased individuals. However, even when the individual documented is deceased, you have to judge what problems the records might cause living relatives of the individual.

8. *What should I do if I have materials without signed releases?*

Take the following steps to protect your park:

- ***Inform researchers they must obtain permission from the relevant individual(s).***
- ***Follow the NPS records schedule in the Records Management Guideline*** (formerly NPS-19) to transfer or dispose of employment, law enforcement, medical, and similar records as required by law.

Most NPS records with privacy issues, such as employment and medical records, shouldn't become part of museum collections, but instead should go to the National Archives and Records Administration (NARA). For records of related organizations, such as concessionaires, don't make the materials available unless the persons involved are no longer living.

Even when the individual documented is deceased, you have to judge what problems the records might cause relatives of the individual. For example, personnel records might indicate psychiatric or medical histories that the family does not want to share with the public. These decisions should be made on a case-by-case basis during the appraisal process prior to accessioning.

- ***Don't provide access to medical, legal, psychiatric, personnel, or other private records,*** except for subpoenas and federal audits. Requests for employee records found in corporate archives or personal papers within NPS collections, such as the Thomas A. Edison or Frederick Law Olmsted papers, should be referred to your solicitor, administrative officer, and, where appropriate, FOIA officer. Records of living federally employed individuals should be in the personnel office, not the museum collection. Refer all such requests for records of federal employees to your administrative officer, through your superintendent.
- ***Talk to the NPS solicitor and FOIA officer*** about potentially private materials. Be conservative with private information. Don't allow use of these records without the NPS solicitor's approval.
- ***Don't publish, exhibit, distribute, or authorize others to use this potentially private material*** in publications, exhibitions, or other public distributions, such as the World Wide Web, without the subject's permission (even if the individual documented was a child

when the materials were produced).

- ***Consult with the appropriate discipline specialist if the materials document a particular culture, but you can't locate the individuals documented.*** Working with the anthropologist or ethnographer, contact the appropriate cultural group to identify the individuals documented, obtain permissions, and determine if the use is appropriate. If permission from identifiable individuals in the material is not available, do not publish, exhibit or authorize others to do so.

See Chapter 1: Evaluating and Documenting Museum Collections Use, Section E, Cultural Issues.

9. *How do the courts enforce state privacy laws?*

Each case is decided on its own merits. Generally speaking, courts are particularly hard on any uses that:

- place a private person or group in a misleading light
- embarrass a private person or group
- include any nudity
- result from intrusion on private space or affairs
- disclose medical, psychiatric, employment, or related information

10. *What is the difference between publicity and privacy laws?*

Publicity legislation, which exists in almost half the states, protects the rights of celebrities to benefit from any use of their name, face, image, voice, and other aspects of their image or persona for commercial gain. These state laws, which apply to federal entities within the state, limit commercial use of museum objects that illustrate or capture the image, voice, or persona of celebrities without permission of the celebrities portrayed or their estates.

State privacy legislation overlaps somewhat with publicity legislation enacted by such states as California, New York, and Tennessee. Both privacy and publicity legislation are state laws that may vary in content from state to state. These laws may apply to federal collections within the state.

Two major differences exist between privacy and publicity legislation:

- Privacy is a non-commercial right, while publicity is a commercial right.
- In some states, publicity rights extend after death and may be enforced by the estates of celebrities, while privacy rights always end at death.

Whether and how the publicity right applies depends on the applicable state law—some states do not recognize it, and no federal law applies. However, the number of states recognizing some version of publicity law

is growing rapidly. NPS staff should seek written permission from celebrities or their families (some states extend the right for a period after death) for all NPS uses of their persona, particularly if a proposed use is more commercial than educational. If a researcher wishes to use such materials, don't authorize such use until the researcher has obtained written permission from the celebrity.

11. *How do I know if use is potentially illegal?*

First, read this chapter. Then consult with the NPS solicitor and regional curator for guidance if you feel a usage may be illegal. In general, obtain written permission to use the material from celebrities or their heirs, particularly for all commercial uses to avoid potential lawsuits.

12. *How does publicity legislation affect park museum collections?*

Parks in states with publicity legislation should be aware that they must be particularly careful how they use images of celebrities, living or dead. Avoid authorizing such use in writing unless the researcher has obtained written permission from celebrities or their estates. Discuss all commercial or electronic uses of celebrity-related materials with NPS solicitors and regional curators.

G. Other Legal Issues

1. *How do donor restrictions affect use?*

Prior to 1984, parks were advised that donor letters should contain a statement that gifts are unconditional. (See *Manual for Museums*, Chapter 2, How to Acquire.) Since 1984, NPS policy, as noted in *MH-II*, Chapter 2, Accessions, Figure 2: Deed of Gift, is to accession only unrestricted donations. Although counter to NPS policy, some materials may have been received with donor restrictions. Donor restrictions act as a binding contract between the museum and the donor. If you discover materials within your collection that have donor restrictions, honor them to the extent allowed by law. *Note:* at the time of the accession, park staff need to inform donors/sources of accession that files are protected to the extent of the law.

The NPS must follow FOIA procedures and may not deny materials requested through FOIA or subpoena automatically because of donor restrictions. Occasionally, FOIA and donor restrictions clash, with FOIA requiring access to materials that are denied under donor restrictions. When donor restricted materials are requested under FOIA, the case must be decided individually. Ask your superintendent, NPS solicitor, FOIA officer, and regional curator for guidance.

2. *What is meant by sensitive information?*

In general, sensitive information is a catch-all category of privileged, exclusive, private, or restricted information that isn't protected by law(s). Restricting access to such information rarely has any legal basis. You need to honor restrictions to the extent permitted by law. However, in the absence of a donor restriction or a legal basis, sensitive information must be provided when requested by FOIA. Contact the NPS FOIA officer and solicitor for guidance. For more information see Chapter 1, Section D, Ethical Issues, and E, Cultural Issues.

3. *What slander and libel laws affect use of*

State defamation law generally provides recourse for publication (communication to a third party) of *false* written (libel) or spoken (slander)

museum collections?

remarks that hold *living* persons or corporations up to hatred, contempt, or ridicule. Most state defamation law doesn't apply to the dead, allowing unlimited commentary without recourse. The medium and method of communication can sometimes affect whether a statement is viewed as defamatory or not.

Materials most frequently affected by slander and libel laws are:

- oral and video history tapes and transcripts
- correspondence, particularly informal correspondence, such as memos and e-mail
- diaries

Of these materials, the most likely to pose problems for park museum staff are back-up tapes from e-mail systems requested via FOIA and oral and video history tapes and transcripts. If you have such materials that contain defamatory content, contact your regional curator. If you receive FOIA requests for this material, also contact your park FOIA officer and the NPS solicitor.

4. *What is obscenity, and how does it concern museum collections?*

Obscenity is indecent, lewd, or offensive expression. There are state and federal criminal penalties for those who provide obscene material to the public. Laws and standards dealing with obscenity vary by state. Generally, the following are obscene:

- ***Nudity***, particularly in photographs, is often judged to be obscene by state and local courts. Nude images of children are particularly inflammatory according to recent legal rulings. Don't publish nudes of children unless they are essential to your work and you have cleared the use with the NPS solicitor and your Regional curator.
- ***Visual depiction of a minor engaged in sexually explicit conduct***, including "lascivious exhibition of the genitals," should ***not*** be reproduced, exhibited, or distributed (such as on the Internet) without first obtaining the consent of the NPS solicitor and consulting with an appropriate discipline specialist. Criminal penalties for child pornography make it advisable to avoid exhibiting, publishing, or distributing depictions of nude children, even if disseminated for academic purposes. Dissemination of an image (not just the solicitation of a minor to pose for such images) may result in criminal penalty, even in the absence of any commercial purpose.

5. *What pictures of nudes are exempt from obscenity concerns?*

Practically speaking, none are exempt although educational, medical, or scientific images disseminated for legitimate academic purposes are less likely to be judged sexually explicit. For example, facing a court challenge for displaying a Renoir nude in a fine art museum is unlikely. An equivalently posed nude taken as a contemporary color photograph and distributed online without context is more likely to receive an obscenity challenge.

If, however, the photo is the source material for a painting held by the

NPS that is being critically studied in the publication, the danger again recedes. Handling concerns of this nature is a matter of risk management and should be done in conjunction with a NPS solicitor familiar with these concerns.

6. *How can I manage nude images that I have in my collection?*

If your collections or potential donations contain images that depict nudity, consider consulting a group of discipline specialists. An informal, professional advisory group can substantively evaluate the artistic, scientific, or educational merit of disseminating particular materials and ensure that all delicate matters and culturally sensitive materials are presented appropriately.

Such good-faith efforts will stand you in good stead if you are ever taken to court. Your access and use policy should recognize these issues, require an evaluation of the reason for and merit of disseminating sensitive images, and direct staff to consult with the NPS solicitor for assistance.

7. *How does evolving case law affect my practices?*

Case law can totally change the meaning of an act or how a piece of legislation is interpreted. Case law, unfortunately, is fluid and changes rapidly. You can learn about recent changes by reading professional museum publications and a major newspaper, and by consulting with the NPS solicitor.

8. *Do restrictions for National Defense, Foreign Policy, and Classified Data affect museum collection use?*

Yes, particularly former military installations such as forts or bases, may encounter this problem. If you find classified, national defense, or foreign policy documents or objects in your collections marked with restrictions, replace them with a separation sheet or “object temporarily removed” tag, lock up the originals, and contact the NPS solicitor and your regional curator. They can help you determine how to contact the appropriate government agency for declassification or review, regardless of the document's age. See MH-II, Appendix D, Figure D.5, for separation sheets.

9. *What are the restrictions for access to internal personnel rules and practices?*

Refer requests for information concerning internal personnel rules and practices to your administrative officer. If the request is a FOIA request, also check with your FOIA officer, superintendent, and regional public relations officer. In general, policy documents are provided upon request under FOIA.

H. Patent Laws

1. *What are patents?*

Patents (U.S. Constitution, Article I, Section 8 and 35 USC 101-376) are a form of intellectual property protection for machines, objects, and processes. Patents are authorizations granted by the government to inventors and/or their employers to exclusively produce, sell, or use an invention within the United States.

2. *How do patents protect inventions?*

Patents prohibit individuals other than creators of an item from making, using, selling, or offering for sale patent protected items in the United States.

3. *What can be protected by*

Inventions, such as machines, objects, and processes can be protected by

patents?

patents. Ideas, suggestions, and natural or physical processes may NOT be patented.

4. *How do patents affect museums and scholars?*

Patents have relatively little impact on museums. There are no restrictions on viewing, exhibiting, or documenting patented items. In fact, once an item is patented anyone may request and purchase detailed drawings of the patented item from the U.S. Patent Office. However, museums may NOT make working replicas or 3-D reproductions of patented items without permission from the patent holder.

5. *What is the period of patent protection?*

Utility patents, protecting the way an invention is used and works, are for 20 years from the date of the filing of the patent application for applications filed on or after June 8, 1995, or if the application contains a specific reference to an earlier application under 35 USC 120, 121, or 365(c), 20 years from the earliest effective U.S. filing date. Design patents, protecting the way an article looks, are for 14 years from the date the patent is granted.

I. Trademarks and Servicemarks

1. *What are trademarks?*

Trademarks are distinctive symbols, logos, and/or words used by businesses or other organizations to identify the source of a product or service. Businesses create trademarks so that their products can be easily distinguished from their competitor's products.

2. *How are trademarks different from servicemarks?*

Trademarks appear only on products as indications of the source of goods. Servicemarks are used to distinguish the source of services. Both measures are "branding" tools that indicate sources and qualities of either goods or services provided by merchants and organizations.

3. *Why do businesses have trademarks and servicemarks?*

Trademarks and servicemarks protect the reputation of a company and make it easy to distinguish a company's products and services from those of competitors. Use of a trade or servicemark serves the purpose of crediting the group that created the object or offered the service, keeping others from claiming credit or misleading potential customers as to the type or quality of materials and services offered.

4. *How do trademarks and servicemarks affect museums?*

Museums may claim trademark or servicemark protection for the name of the museum and any logos associated with the museum, including special exhibitions, when used in connection with a product or service provided by the museum, such as museum store items or restaurant operations. NPS protects the NPS arrowhead and DOI logos as trademarks.

When using another organization's trademark, such as on a website or identifying a NPS partner in exhibit materials, NPS must request permission to use the trademark.

5. *Must I register for trademark and servicemark protection?*

No. As soon as an organization uses a distinctive mark regularly and consistently the organization has common law trademark and servicemark protection. However, the mark must be distinct from that of other organizations and the museum must be the first organization to use that mark.

If another organization can show prior use, ownership, or a significant amount of consumer confusion as to the ownership or source of the mark, the mark's validity can be revoked or ownership can be reappraised. Federal registration grants additional rights in case of a legal conflict. Many states also offer some form of trademark and/or servicemark protection.

6. *How long do trademark or servicemark protections last?*

Trademarks and servicemarks registered prior to November 16, 1989 are initially protected for 20 years while those subsequently registered are initially protected for 10 years. Trademarks and servicemarks may be renewed indefinitely for additional 10 year periods as long as the mark is still being used in commerce.

J. List of Figures

2.1 Access and Use Legal Action Chart.....	2:43
2.2 Sample License Agreement.	2:50

Figure 2.1. Access and Use Legal Action

Access and Use Legal Action Chart		
Type of Request The Researcher (NPS or External) asks for . . .	Applicable Legislation or Restrictions	Appropriate Action You, as Park Staff, should . . .
<p>Any work (published or unpublished) produced by NPS staff, contractors, volunteers or other federal employees as part of their normal work, including:</p> <ul style="list-style-type: none"> • art works • audiotapes • field notes • photographs • published and unpublished writings • reports • research notes • videotapes <p><i>Note:</i> NPS contract work may also fall in this category depending upon the terms of the contract. See C.7.</p>	<ul style="list-style-type: none"> • Archeological Resources Protection Act • Endangered Species Act of 1973 as amended (16 USC 1531-1543) • FOIA • Federal Cave Protection Act of 1988 (16 USC 4301-4309) • National Historic Preservation Act • National Parks Omnibus Management Act of 1998 • Obscenity and Pornography • Privacy • Publicity • Slander and libel • Visual Artist’s Rights Act • Cultural restrictions • Ethical restrictions 	<ul style="list-style-type: none"> • Allow the researcher to use the work without copyright restrictions as all federally produced work is in the public domain, as long as there are no other restrictions (cultural or natural resource management protection, ethical, or legal restrictions). • Credit all works appropriately to the correct creator. • Instruct the researcher in writing to obtain written permission (also called a release) from any private non-federal individuals illustrated, taped, or documented before copying, publishing, distributing, preparing derivative works, or exhibiting. • Instruct the researcher in writing to obtain written permission from a celebrity or a celebrity's estate <i>before</i> using the material commercially or in a publication. • Contact your superintendent, regional public affairs officer, regional curator, and FOIA officer immediately if the reference request comes via FOIA. • Review the publication context with subject specialists and the NPS solicitor <i>before</i> allowing publication of any images of nudes or potentially defamatory materials. • See archeological research below. • Have the researcher sign a researcher registration form and a copyright/privacy statement <i>before</i> authorizing use. (See <i>MH-II</i>, Appendix D, Figures D.15 and D.16.)
<p>Any work held by NPS museum collections that has a donor restriction</p> <p><i>Note:</i> NPS policy (as noted in <i>MH-II</i>, Chapter 2, Deed of Gift) is to accept only unrestricted gifts. The NPS will honor existing donor restrictions to the extent permitted by law.</p>	<ul style="list-style-type: none"> • All of the above • Donor restriction 	<ul style="list-style-type: none"> • Check for donor, legal, cultural, natural and cultural resource management, and ethical restrictions <i>before</i> providing access. • Honor restrictions to the fullest extent allowed by the law. • Consult with the NPS solicitor to determine to what extent the law allows you to honor the restriction. Also speak to your regional curator and any associated groups, if appropriate. • Consult with your superintendent, regional public affairs officer, regional curator, and FOIA officer if the reference request comes via FOIA. You <i>must</i> respond to the FOIA request within 20 days. • Have the researcher sign a researcher registration form and a copyright/privacy statement <i>before</i> authorizing use. (See <i>MH-II</i>, Appendix D, Figures D.15 and D.16.)

Access and Use Legal Action Chart		
Type of Request The Researcher (NPS or External) asks for . . .	Applicable Legislation or Restrictions	Appropriate Action You, as Park Staff, should . . .
<p>Moving or still audio-visual images or recorded words of living recognizable people or celebrities (living or dead) taken by individuals other than NPS staff including:</p> <ul style="list-style-type: none"> • audiotapes • electronic audio/video files • motion picture recordings • oral history audiotapes • oral history transcripts • still images, including photographs • video history videotapes • video history transcripts 	<ul style="list-style-type: none"> • Donor restriction • Copyright • Privacy • Publicity • FOIA • Obscenity and Pornography • Slander and libel • Cultural restrictions • Ethical restrictions 	<ul style="list-style-type: none"> • Check for donor, cultural, ethical, or legal restrictions <i>before</i> providing access. • Consult with your regional curator and the NPS solicitor. • Honor restrictions to the fullest extent allowed by the law. • Allow the researcher to view and use materials for fair use purposes <i>if</i> no restrictions exist. • Don't authorize publication unless the work is in the public domain or the park has the copyright or permission to allow publication from the copyright holder. • Instruct the researcher in writing to obtain written permission from the celebrity or the celebrity's estate before using the material commercially or in a publication. • Talk to your superintendent, regional public affairs officer, regional curator, and FOIA officer if the reference request comes via FOIA. See if a FOIA exemption, such as the privacy exemption, applies. • Review the situation with subject specialists and the NPS solicitor before allowing publication of any images of nudes or potentially defamatory materials. • Have the researcher sign a researcher registration form and a copyright and privacy statement <i>before</i> authorizing use. (See <i>MH-II</i>, Appendix D, Figures D.15 and D.16.)

Access and Use Legal Action Chart

<p style="text-align: center;">Type of Request The Researcher (NPS or External) asks for . . .</p>	<p style="text-align: center;">Applicable Legislation or Restrictions</p>	<p style="text-align: center;">Appropriate Action You, as Park Staff, should . . .</p>
<p>Unpublished written materials, by individuals <i>other</i> than NPS staff, such as:</p> <ul style="list-style-type: none"> • correspondence • diaries • daybooks • ledgers • lists • manuscripts • notes 	<ul style="list-style-type: none"> • Donor restrictions • Copyright • FOIA • Privacy • Publicity • Obscenity and pornography • Libel • Cultural restrictions • Ethical restrictions • Archeological Resources Protection Act • National Parks Omnibus Management Act of 1998 • National Historic Preservation Act 	<ul style="list-style-type: none"> • Check for donor, cultural, natural and cultural resource management, ethical, or legal restrictions <i>before</i> providing access. • Determine if a FOIA exemption applies. • Talk to the NPS solicitor and your regional curator. • Honor restrictions to the fullest extent allowed by the law. • Allow the researcher to view and use copyright-protected work only for fair use purposes (if no other restrictions exist). • Don't authorize publication (grant permission to publish) unless the work is in the public domain or the park has the copyright or permission to allow publication from the copyright holder • Allow unlimited use of unrestricted materials that are in the public domain. • Talk to your superintendent, regional public affairs officer, regional curator, and FOIA officer if the reference request comes via FOIA. • Instruct the researcher to obtain written permission from the person quoted or shown or his or her heirs <i>before</i> the researcher publishes, distributes, or otherwise uses the item if the person shown is either a celebrity or a living, private individual. • Review the request with subject specialists and the NPS solicitor <i>before</i> allowing publication of any nudes or potentially defamatory materials. • Have the researcher sign a researcher registration form and a copyright/privacy restrictions statement <i>before</i> authorizing use. (See <i>MH-II</i>, Appendix D, Figures D.15 and D.16.)
<p>Published written or recorded materials produced by non-NPS individuals, such as:</p> <ul style="list-style-type: none"> • articles • books • exhibit catalogs • pamphlets • published manuscripts • reports created by individuals <i>other</i> than NPS staff 	<ul style="list-style-type: none"> • Copyright • FOIA • Donor restrictions • Cultural restrictions • Ethical restrictions 	<ul style="list-style-type: none"> • Allow the researcher to view, use for fair use purposes, and make a limited number of copies of a <i>small or insignificant</i> portion of the work if no restrictions apply. For example: let researchers copy a few pages of a long manuscript if the work is not in the public domain. See Section C, Questions 9 and 10. • Instruct the researcher to obtain written permission from the holder of the copyright <i>before</i> the researcher copies, publishes, distributes, prepares derivative works, performs, or exhibits. • Don't authorize re-publication in any format (including published use of extensive quotes) unless the work is in the public domain, <i>or</i> the NPS has the copyrights <i>or</i> permission to allow publication from the holder of the copyrights. • Talk to your superintendent, regional public affairs officer, regional curator, and FOIA officer if the reference request comes via FOIA. Determine if there is a FOIA exemption that applies.

Access and Use Legal Action Chart		
Type of Request The Researcher (NPS or External) asks for . . .	Applicable Legislation or Restrictions	Appropriate Action You, as Park Staff, should . . .
		<ul style="list-style-type: none"> • Ensure the researcher signs a researcher registration form and a copyright/privacy restriction statement <i>before</i> authorizing use. (See <i>MH-II</i>, Appendix D, Figures D.15 and D.16.)
<p>Archeological research materials such as:</p> <ul style="list-style-type: none"> • charts • databases • field diaries • geographic information system records • graphics • journals or day books • maps • notes • photographs <p><i>Note:</i> You must deny access to records (including catalog records and databases unless they are set up to electronically block the fields) containing archeological location information such as:</p> <ul style="list-style-type: none"> • archeological resources, including excavations and shipwrecks • caves and cave resources • historic resources at risk of harm, theft, or destruction 	<ul style="list-style-type: none"> • Archeological Resources Protection Act (ARPA) of 1979 (16 USC 470) • Executive Order 13007—Indian Sacred Sites • Federal Cave Protection Act of 1988 (16 USC 4301-4309) • National Historic Preservation Act of 1966, as amended (16 USC 470-470t,110) • National Parks Omnibus Management Act of 1998 • FOIA • Copyright • Donor restrictions • Cultural restrictions • Ethical restrictions 	<ul style="list-style-type: none"> • Withhold location information on archeological sites or shipwrecks to prevent looting. • Withhold location information on sacred sites. • Withhold location information on federally-protected caves if disclosure would create a risk of harm, theft, or destruction. • Withhold information on historic resource location, ownership, or character, if the disclosure creates a substantial risk of harm, theft, or destruction of such resources or the area or place where they are located • Deny access to the above-described materials, <i>including</i> access for scholarly research. Replace restricted items with a separation sheet and lock up the originals if they pose a disclosure problem. Block the restricted information on catalog cards, databases and the Web Catalog. Don't restrict the entire collection or unblocked data. <i>Don't alter originals.</i> • Consult with the NPS solicitor, FOIA officer, your superintendent, regional public relations officer, and your regional curator. Follow FOIA denial procedures for both NHPA and FOIA. • Work with subject specialists to determine if a portion of the information can be provided as long as no location information is included. • Have the researcher sign a researcher registration form and a copyright/privacy restrictions statement before authorizing use if some information is provided (see <i>MH-II</i>, Appendix D, Figure D.15 and 16). • Determine if the records were produced by NPS staff during work hours and are Federal records with no copyright protection or by non-Federal staff or contractors without a copyright statement in their contract. If the latter, copyright permissions may be necessary before providing materials.
<p>Ethnological field records that incorporate information of a sensitive, sacred, or subsistence-related character including:</p> <ul style="list-style-type: none"> • charts • databases • field diaries • geographic information system records 	<ul style="list-style-type: none"> • Archeological Resources Protection Act (ARPA) of 1979 (16 USC 470) • Copyright • Executive Order 13007 Indian Sacred Sites • National Historic Preservation Act of 1966, as amended 	<ul style="list-style-type: none"> • Check for donor, cultural, ethical, and legal restrictions <i>before</i> providing access. • Talk to the NPS solicitor, regional curator, and the associated group when devising access policies and when questions arise. • Honor restrictions to the fullest extent allowed by the law. • Consult with your superintendent, regional public relations officer, Regional curator, and FOIA officer if the reference request comes via FOIA. Determine if a statutory exemption to FOIA is applicable, such as the privacy exemption.

Access and Use Legal Action Chart

<p align="center">Type of Request The Researcher (NPS or External) asks for . . .</p>	<p align="center">Applicable Legislation or Restrictions</p>	<p align="center">Appropriate Action You, as Park Staff, should . . .</p>
<ul style="list-style-type: none"> • graphics • journals or day books • maps • notes • photographs • oral histories • videotapes 	<p>(16 USC 470-470t,110)</p> <ul style="list-style-type: none"> • National Parks Omnibus Management Act of 1998 • Donor restrictions • FOIA • Privacy • Publicity • Cultural restrictions • Ethical restrictions 	<ul style="list-style-type: none"> • Withhold information on historic resource location if the disclosure creates a substantial risk of harm, theft, or destruction of such resources or the area where they are located. • Inform researchers in writing that they may need to obtain written permission from the person(s) quoted or shown, or his heirs <i>before</i> publishing, distributing, producing derivative works, etc., if the person shown is a celebrity or a living, private individual. • Have the researcher sign a researcher registration form and a copyright/privacy restriction statement <i>before</i> authorizing use. (See <i>MH-II</i>, Appendix D, Figures D.15 and D.16.) • Determine if the records were produced by NPS staff during work hours and are federal records with no copyright protection, <i>or</i> by contractors without a copyright statement in their contract (may be copyrighted). If the latter, copyright permissions may be necessary before providing materials for use.
<p>Photographic, digital, micrographic, or xerographic copies of NPS-owned museum objects requested for:</p> <ul style="list-style-type: none"> • potential publication • exhibition • performance • distribution • production of derivative works, such as postcards of paintings. <p>Requested materials for copies might include:</p> <ul style="list-style-type: none"> • architectural drawings • bound volumes • drawings • exhibits • graphic prints • herbarium specimens • manuscripts of poems and plays • maps • mounted animals • paintings • photographs • sculpture • other original works 	<ul style="list-style-type: none"> • Donor restrictions • Copyright • Privacy • Publicity • FOIA • Cultural restrictions • Ethical restrictions • National Park Omnibus Management Act • Obscenity and Pornography • Slander and libel 	<ul style="list-style-type: none"> • Check for donor, cultural, ethical, natural and cultural resource management, and legal restrictions <i>before</i> providing copies. • Consult with the NPS solicitor and your regional curator. • Honor restrictions to the fullest extent allowed by the law. • Allow the researcher to view and obtain limited copies for fair use purposes if no donor restrictions apply. Don't authorize copying, publication, distribution, or the production of derivative works <i>unless</i> the work is in the public domain <i>or</i> the park has the copyrights <i>or</i> permission to allow these activities from the copyrights holder. • Inform the researcher that according to Section 106(A) of the Copyright Act of 1976, some visual artists have a right to proper attribution (credit) to their works and maintenance of the integrity of their works (no image modifications such as “morphing”). • Instruct the researcher in writing to obtain written permission from the persons quoted or shown or their estates <i>before</i> publishing or distributing the materials. • Talk to your superintendent, regional public relations officer, regional curator, and FOIA officer if the reference request comes via FOIA. Determine if a statutory exemption to FOIA applies, such as the privacy exemption. • Review carefully the situation with subject specialists and the NPS solicitor before allowing publication of any nudes or potentially defamatory materials. • Restrict access to information on objects of cultural patrimony, as well as documents containing information on the specific nature and location of a threatened, rare, or commercially valuable mineral, or paleontological

Access and Use Legal Action Chart		
Type of Request The Researcher (NPS or External) asks for . . .	Applicable Legislation or Restrictions	Appropriate Action You, as Park Staff, should . . .
		<p>specimens, unless the Service determines, in writing, that disclosure would further the park mission and not create an unreasonable risk of harm, theft, or destruction to the resource, and would be consistent with other applicable laws. Consult with the regional curator and the NPS solicitor before releasing such information.</p> <ul style="list-style-type: none"> • Have the researcher sign a researcher registration form and a copyright/privacy restrictions statement <i>before</i> authorizing use. (See <i>MH-II</i>, App D, Figures D.15 and D.16.)
<p>Permission to create facsimile (near identical copies in the same media, same process, and same format) reproductions of original works of creativity, such as:</p> <ul style="list-style-type: none"> • furniture • graphic prints • paintings • photography • sculpture • wallpaper • ceramics • beadwork • quilts • costumes 	<ul style="list-style-type: none"> • Donor restrictions • Copyright • FOIA • Privacy • Publicity • Obscenity and pornography • Cultural restrictions • Ethical restrictions 	<ul style="list-style-type: none"> • Check for donor, cultural, ethical, natural and cultural resource management, and legal restrictions <i>before</i> providing permission. • Talk to the NPS solicitor and regional curator. • Honor restrictions to the fullest extent allowed by the law. • Allow the researcher to view and use for fair use purposes if no restrictions apply. Making facsimiles or reproductions for sale is <i>not</i> a fair use. • Instruct the researcher to obtain permission from the copyright holder, unless the facsimiles are being made for preservation, security, or deposit in another repository. • Not authorize reproductions in writing unless you are certain the work is in the public domain <i>or</i> the park owns the copyright, <i>or</i> the park has appropriate written permissions from the copyright holder. • Inform the researcher that according to Section 106(A) of the Copyright Act of 1976, visual artists have a right to proper attribution (credit) of their works and maintenance of the integrity of their works (no modifications such as morphing, digital image manipulation). • Consult with your superintendent, regional public relations officer, regional curator, and FOIA officer to discover if a statutory exemption to FOIA is applicable, such as the privacy exemption, if the reference request comes via FOIA. • Instruct the researchers in writing that they may need to obtain written permission from the persons quoted or shown (identifiable models) before publishing or using commercially. • Not authorize facsimiles <i>until</i> permission is obtained unless the model shown is both dead and not a celebrity and your state law allows this. • Review the situation with subject specialists and the NPS solicitor <i>before</i> allowing publication of any images of nudes or potentially defamatory materials.

Access and Use Legal Action Chart		
Type of Request The Researcher (NPS or External) asks for . . .	Applicable Legislation or Restrictions	Appropriate Action You, as Park Staff, should . . .
Information or files that are labeled "classified" or "restricted" by the U.S. military or intelligence community, regardless of the date of the material.	<ul style="list-style-type: none"> FOIA 	<ul style="list-style-type: none"> Withhold this information. Replace the original document with a completed separation sheet. Lock up the original. If the restricted information is in electronic format, make a copy for access and redact (delete) the restricted information on the copy. Only the classified or restricted material is restricted, not the entire collection or file. Consult with the NPS solicitor and your regional curator about how to make arrangements for declassifying or unrestricting the document with the appropriate branch of the government. You may also ask for help from the National Archives and Records Administration to determine how best to proceed. Work with your superintendent, regional public relations officer, regional curator, and FOIA officer if the request has come through FOIA to ensure proper procedures are followed in denying the request.
Information protected by other FOIA exemptions, including: <ul style="list-style-type: none"> Files of privileged intra-agency communications (<i>Note</i>: Covers very little.) Trade secrets of concessionaires held by the park in trust Financial records Personnel records of living individuals Psychiatric, medical, or counseling records of living individuals Law enforcement and investigatory records that include documentation on living individuals 	<ul style="list-style-type: none"> FOIA Privacy 	<ul style="list-style-type: none"> Withhold this information. Consult with the NPS solicitor and your regional curator about how to proceed. Replace the document with a completed separation sheet. Lock up the original. If in electronic format, make a copy for access purposes with the restricted materials deleted on the copy. Only the problematic material is restricted, not the entire collection. Work with your superintendent, regional public relations officer, regional curator, and FOIA officer if the request has come through FOIA to ensure that all the proper procedures are followed in denying the request. Work with subject specialists and the NPS solicitor to determine if a portion of the information can be provided, while still maintaining the secrecy of the restricted materials.
Materials, such as files, tapes, or videotapes that contain false and misleading information about a third party that may defame that third party. <i>Note</i> : This is one reason why you should discourage access to unprocessed (unaccessioned, uncataloged, unarranged, and undescribed archival and manuscript) materials.	<ul style="list-style-type: none"> Slander and libel Privacy FOIA 	<ul style="list-style-type: none"> Allow access if the individuals referenced are dead. If the individuals referenced are alive, <i>don't</i> allow copying or publication. Ask your solicitor if state defamation law restricts the material. Call the NPS solicitor and your regional curator immediately. Work with your superintendent, regional public relations officer, regional curator, and FOIA officer if the request has come through FOIA to ensure proper procedures are followed in denying the request. Work with subject specialists and the NPS solicitor to determine if a portion of the information can be provided while still preventing a defamation lawsuit.

Access and Use Legal Action Chart		
Type of Request The Researcher (NPS or External) asks for . . .	Applicable Legislation or Restrictions	Appropriate Action You, as Park Staff, should . . .
		<ul style="list-style-type: none"> • Have the researcher sign a researcher registration form and a copyright/privacy restrictions statement <i>before</i> you authorize use of any information. (See <i>MH-II</i>, Appendix D, Figures D.15 and D.16.)
<p>Paintings, sculptures, and photographs (including historical anthropological photography) of nude people (particularly children) and similar materials that may be judged obscene or pornographic.</p>	<ul style="list-style-type: none"> • Obscenity and pornography • FOIA 	<ul style="list-style-type: none"> • Not allow copying or publication of materials that may be judged obscene or pornographic, particularly nudes of children. Talk to your regional curator and the NPS solicitor before allowing any copying or publication of such materials. • Work with subject specialists to provide an appropriate scientific, fine art, or equivalent context for nude imagery. • Work with your superintendent, regional public relations officer, FOIA officer, the NPS solicitor, and your Regional curator to determine how to proceed if a request for this material comes via FOIA (applicable only to documents or photos). • Have the researcher sign a researcher registration form and a copyright/privacy restrictions statement <i>before</i> authorizing use if some information is provided. (See <i>MH-II</i>, Appendix D, Figures D.15 and D.16.)
Files that have been subpoenaed.		<ul style="list-style-type: none"> • Call your regional curator and the NPS solicitor immediately for advice.
Information on the nature and specific location of a NPS resource which is endangered, threatened, rare, or commercially valuable of mineral or paleontological objects or objects of cultural patrimony within the NPS or of an archeological site or burial.	<ul style="list-style-type: none"> • National Parks Omnibus Management Act of 1998 • ARPA • National Historic Preservation Act of 1966, as amended (16 USC 470-470t,110) 	<p>Consult with your regional curator on receiving such a request. Refer all such requests, whether written or oral, to the superintendent, park T & E officer, and archeologist or paleontologist. You may be asked to collect response data or to draft a response for the Superintendent's signature.</p> <ul style="list-style-type: none"> • Restrict information and records containing information on the nature and location of archeological sites. • Restrict information and records containing the nature and location of mineral and paleontological sites if rare, endangered, threatened, or commercially valuable. • Restrict information or records containing the nature and location of objects of cultural patrimony found within the NPS.
Information and files as part of a federal audit process.		<ul style="list-style-type: none"> • Provide the information, unless it falls into a FOIA exemption category (such as classified, protected cave and well location, and archeological site location) in which case you should withhold it. • Withhold the information until you check with the superintendent, NPS solicitor, FOIA officer, and your Regional curator if you are uncertain about whether there is a restriction. Check <i>very</i> rapidly.

Figure 2.2. Sample License Agreement

LICENSE AGREEMENT		
<p>I, _____, am the owner or am authorized to act on behalf of the owner of certain materials described below, including copyright that the National Park Service has requested to use and reproduce. (If not the copyright owner, please specify in the space below any additional permissions needed, if any, to grant these rights.) I hereby grant to the National Park Service a royalty-free, irrevocable, and non-exclusive license to use the materials specified herein for non-profit National Park Service uses, including educational, exhibition, archival, and research uses. These materials may be used, reproduced and displayed for these purposes in any and all medium including, but not limited to, the World Wide Web.</p>		
Restrictions on Use of Materials, if any: _____.		
Types of Materials (please check):		
Photographs _____	Illustrations _____	Textual materials _____ Oral History/Interviews _____
Audiotape _____	Videotape _____	Other (describe) _____
Detailed Description of Materials: _____.		
Credit Line and/or Caption: _____.		
Additional Permissions Needed, if any (for example, copyright owner, subjects in photographs, illustrations, and in text): _____.		
Disposition of Materials After Use (please check one): _____ Return to owner: _____ May be retained		
Warranty: I warrant and represent that I am or legally represent the owner of the materials described, including copyright, and that I have the full authority to grant the requested license. If the materials include materials for which multiple permissions are required, I warrant that I have obtained all necessary permissions, including without limitation, copyright and rights of privacy and publicity, from the rights-holders or have specified on the "Additional Permissions" line, above, all additional permissions that the National Park Service must obtain to fully exercise the rights granted herein.		
_____ Name (please print)	_____ Signature	_____ Date
Address		
Telephone Number:		
Fax Number:		
Email:		

Figure 2.2. Sample License Agreement

K. Bibliography

- Anderson, Carolyn, and Thomas W. Benson. "Direct Cinema and the Myth of Informed Consent: The Case of Titcut Follies." In *Image Ethics: The Moral Rights of Subjects in Photographs, Film, and Television*, edited by Larry Gross, John Stuart Katz, and Jay Ruby, 58-90. New York: Oxford University Press, 1988.
- Aoki, Keith. "(Intellectual) Property and Sovereignty: Notes Toward a Cultural Geography of Authorship." *Stanford Law Review* 48, no. 5 (1996): 1293-1355.
- Ardito, Stephanie. "The Information Broker and Intellectual Property Rights." *Bulletin of the American Society for Information Science* 21, no. 3 (Feb/March 1995): 19-20.
- Barlow, John Perry. "Selling Wine Without Bottles: The Economy of Mind on the Global Net." <http://www.eff.org/pub/Intellectual_property> Accessed 1 January 1996.
- Baron, Robert, ed. "The Great Image Debate." *Visual Resources* 22, nos. 3-4 (1997).
- Bennett, Scott. "The Copyright Challenge: Strengthening the Public Interest in the Digital Age." *Library Journal* 119, no. 19 (Nov 15, 1994): 34-37.
- Berryman, Cathryn A. "Toward More Universal Protection of Intangible Cultural Property." *Journal of Intellectual Property Law* 1, no. 2 (1994): 293-333.
- Boyle, James. *Shamans, Software, and Spleens: Law and the Deconstruction of the Information Society*. Cambridge, Mass.: Harvard University Press, 1996.
- Branscomb, Anne Wells. "Public and Private Domains of Information: Defining the Legal Boundaries." *Bulletin of the American Society for Information Science* 21, no. 2 (Dec/Jan 1995): 14-18.
- _____. *Who Owns Information: From Privacy to Public Access*. New York: Basic Books, 1995.
- Brinson, J. Dianne, and Mark F. Radcliffe. *MultiMedia Law and Business Handbook: A Practical Guide for Developers and Publishers*. New York: Ladera Press Quality Books, 1996.
- Brown, Michael F. "Can Culture be Copyrighted?" *Current Anthropology* 39, no. 2 (1998): 193-206.
- _____. *The Channeling Zone: American Spirituality in an Anxious Age*. Cambridge: Harvard Univ. Press, 1997.
- Buck, Rebecca A., and Jean Allman Gilmore, eds. *The New Museum Registration Methods*. 4th ed. Washington, D.C.: American Association of Museums, 1998.
- College Art Association Committee on Intellectual Property, ed. *The College Art Association Guide to Copyright and Fair Use for Art Historians and Artists in Academia*. New York: College Art Association, 1999.
- Cleveland, David A., and Stephen C. Murray. "The World's Crop Genetic Resources and the Rights of Indigenous Farmers." *Current Anthropology* 38 (1997): 477-515.
- Coombe, Rosemary. "Objects of Property and Subjects of Politics: Intellectual Property Laws and Democratic Debate." *Texas Law Review*. 69, no. 7 (1991): 1853-1880.
- _____. "Cultural and Intellectual Properties: Occupying the Colonial Imagination." *Political and Legal Anthropology Review* 16 (March 1993): 8-15.

- Conley, Diane. "Author, User, Scholar, Thief: Fair Use and Unpublished Works." *Cardozo Arts and Entertainment Law Journal* 9, no. 1 (1990): 15-60.
- Crawford, Tad. *Business and Legal Forms for Fine Artists*. New York: Allworth Press, 1990.
- _____. *Legal Guide for the Visual Artist: The Professional's Handbook*. 3rd edition. New York: Allworth Press, 1995.
- Crews, Kenneth D. *Copyright, Fair Use, and the Challenge for Universities: Promoting the Progress of Higher Education*. Chicago: University of Chicago Press, 1993.
- Daes, Erica-Irene. *Study on the protection of the cultural and intellectual property of indigenous peoples*. E/CH.4/Sub.2/1993/28. New York: United Nations Economic and Social Council, Commission on Human Rights, 1993.
- Darraby, Jessica L. *Art, Artifact & Architecture Law*. Rochester, N.Y.: Clark, Boardman, and Callaghan, 1996.
- Feldman, Franklin, and S. E. Weill. *Art Law: Rights and Liabilities of Creators and Collectors*. Boston: Little, Brown and Co., 1988.
- Gasaway, Laura N., and Sarah K. Wiant. *Libraries and Copyright: A Guide to Copyright Law in the 1990s*. Washington, D.C.: Special Libraries Association, 1994.
- Harris, Lesley Ellen. *Digital Property: Currency of the 21st Century*. Toronto: McGraw-Hill Ryerson, Ltd., 1997.
- Hitchcock, Ann. "FOIA and Protecting Cultural Resources." People, Places and Parks: Proceedings of the 2005 George Wright Society Conference on Parks, protected Areas, and Cultural Sites. Hancock, Michigan: The George Wright Society.
- Jaszi, Peter. "On the Author Effect: Contemporary Copyright and Collective Creativity." *Cardozo Arts and Entertainment Law Journal* 10, no. 2 (1992): 293-320.
- Jones-Garmil, Katherine. *The Wired Museum*. Washington, D.C.: American Association of Museums, 1997.
- Lange, David. "Copyright and the Constitution in the Age of Intellectual Property." *Journal of Intellectual Property Law* 1, no. 1 (1993): 119-134.
- _____. "Recognizing the Public Domain." *Law and Contemporary Problems* 44 (1981): 147-178.
- MacNeil, Heather. *Without Consent: The Ethics of Disclosing Personal Information in Public Archives*. Metuchen, N.J.: Scarecrow Press, 1992.
- Malaro, Marie C. *A Legal Primer on Managing Museum Collections*. 2nd ed. Washington, D.C.: Smithsonian Institution Press, 1998.
- McCarthy, J. Thomas. *The Rights of Publicity and Privacy*. Eagan, Minn.: West Group, 1999.
- McClung, Patricia, and Christie Stephenson, eds. *Images Online: Perspectives on the Museum Education Site Licensing Project*. Los Angeles: The J. Paul Getty Trust, 1998.
- Nimmer, Melville B., and David Nimmer. *Nimmer on Copyright*. New York: Matthew Bender & Co., 1998.
- Patry, William F. *The Fair Use Privilege in Copyright Law*. 2nd ed. Washington, D.C.: Bureau of National Affairs

Books, 1995.

- Pask, Amanda. "Cultural Appropriation and the Law: An Analysis of the Legal Regimes Concerning Culture." *Intellectual Property Journal* 8, no. 1 (1993): 57-86.
- Peterson, Gary M., and Trudy Huskamp Peterson. *Archives and Manuscripts: Law*. Chicago: Society of American Archivists, 1985.
- Peters, Marybeth. "The U.S. Copyright System." In *Legal Problems of Museum Administration*, 525-568. Washington, D.C.: ALI-ABA, 1997.
- Puri, Kamal. "Cultural Ownership and Intellectual Property Rights Post-Mabo: Putting Ideas Into Action." *Intellectual Property Journal* 9, no. 3 (1995): 293-347.
- Samuels, Geoffrey, ed. *Sample CD-ROM Licensing Agreements for Museums*. Washington, D.C.: American Association of Museums, 1996.
- Sandager, Elizabeth. "Ethical Implications of the Documentary Record." *New England Archivists Newsletter* 2, no. 2 (1994): 4-6.
- Smith Levine, Melissa. "Electronic Publishing: A Legal and Practical Primer." *CRM* 18, no. 9 (1994): 27-30.
- Shapiro, Michael S. "Not Control, Progress." *Museum News* 76, no. 5 (1998): 37-38 and 41.
- Steiner, Christine. "The Double Edged Sword: Museums and the Fair Use Doctrine." *Museum News* 76, no. 5 (1998): 32-35, 48-49.
- Stephenson, Christie, and Patricia McClung, eds. *Delivering Digital Images: Cultural Heritage Resources for Education*. Los Angeles: The J. Paul Getty Trust, 1998.
- Stephenson, David J., Jr. "A Legal Paradigm for Protecting Traditional Knowledge." In *Intellectual Property Rights for Indigenous Peoples, A Sourcebook*. Edited by Tom Greaves, 179-190. Oklahoma City: Society for Applied Anthropology, 1994.
- Weil, Stephen E. "Not Money, Control." *Museum News* 76, no. 5 (1998): 36, 38, and 41.
- Wolff, Beverly M., ed. "Selected Materials on Copyright Update on Fair Use." In *Legal Problems of Museum Administration*, 569-586. Washington, D.C.: ALI-ABA, 1997.
- Zorich, Diane M. *Introduction to Managing Digital Assets: Options for Cultural and Educational Organizations*. Los Angeles: The J. Paul Getty Trust, 1999.

Web Sites:

Administrative Codes and Registers for States (not federal government) is at
<<http://www.nass.org/acr/acrdir.htm>> .

American Association of Law Libraries is at <<http://www.aallnet.org>> .

American Association of Museums is at <<http://www.aam-us.org/>> .

American Association of Museums Registrars Committee (RARIN) Rights and Reproduction Information Network is at
<<http://www.panix.com/~squigle/rarin/01rcsite.html>> .

American Bar Association is at <<http://www.abanet.org>> .

American Law Institute-American Bar Association is at <<http://www.ali-aba.org>> .

American Library Association is at <<http://www.ala.org>> .

American Law Sources Online (ALSO) at <<http://www.lawsource.com/also>> is a great tool for searching state laws.

Association of American Publishers, Inc. at <<http://www.publishers.org>> provides useful information on how to obtain permission from publishers and authors to use copyrighted works.

Browning, Minde C. ed. *Trademark Resources on the Internet: A Bibliography*.
<<http://www.iulaw.indy.indiana.edu/library/TMRbibliography.htm>>

CataLaw at <<http://www.catalaw.com>> is a basic gateway site for legal information.

Code of Federal Regulations is searchable on the Web at <<http://www.access.gpo.gov/nara/cfr>>

Conference on Fair Use (CONFU) report is at <<http://www.uspto.gov/web/offices/dcom/olia/confu/indexx.html>> .
CONFU is listed on the U.S. Patent and Trademark Office, which is one of the major players in the ongoing effort to revise and update copyright legislation.

Copyright Clearance Center, Inc (CCC) at <<http://www.copyright.com>> CCC is a licensing agency that provides useful linkages to other copyright guidance via its Web site.

Copyright, Intellectual Property Rights, and Licensing Issues at <<http://sunsite.berkeley.edu/Copyright>> is a UC Berkeley Web page that focuses on digital copyright issues.

Cornell University's Legal Information Institute at <<http://www.law.cornell.edu>> is a great place to begin your legal research.

Digital Future Coalition at <<http://www.dfc.org>> is a non-profit organization that focuses on copyright ownership and access rights in a digital environment.

Federal Register is available via the Government Printing Office Web site at
<http://www.access.gpo.gov/su_docs/aces/aces140.html> .

Federal-State Court Directory of the West Publishing Company is at <<http://www.courts.com/directory.html>> .

Federal Web Locator at <<http://www.infoctr.edu/fwl>> provides a links list for online federal agencies, which frequently list publication, regulations, and court or agency decisions.

FindLaw at <<http://www.findlaw.com>> is a general starting point for legal research, particularly the FindLaw Legal News at <<http://legalnews.findlaw.com>> .

Government Printing Office is at <http://www.access.gpo.gov/su_docs> . Also see the Federal Register page at:
<http://www.access.gpo.gov/su_docs/aces/aces140.html> .

Great American Web Site at <<http://www.uncle-sam.com>> provides good coverage of federal agencies regulations.

Harvard Law School's *Basic Intellectual Property Primers* are at
<<http://cyber.law.harvard.edu/property/library/primerlib.html>> . Harvard Law School's Berkman Center for

Internet and Society offers helpful links to intellectual property guidance on such topics as copyright, privacy legislation, publicity legislation, and patent/trademark legislation.

Hieros Gamos at <<http://www.hg.org/hg2.html>> provides a fine gateway to legal information available.

Intellectual Property Information Mall at <<http://www.ipmall.fplc.edu/iptools/NEWMAL2.htm>> provides useful copyright information and links to other information sources.

Internet Legal Resource Guide at <<http://www.ilrg.com>> is a good gateway site leading you to many other legal sites.

Law Journal Extra! provides legal news and updates at: <<http://www.ljx.com>>.

Legal Information Institute at <<http://www4.law.cornell.edu/uscode>> provides excellent basic legal information, such as their copy of the *United States Code*.

Legislative History Resources on the Web include:

Library of Congress's Thomas site is at <<http://thomas.loc.gov>>.

University of Michigan's Legislative History Site is at

<<http://www.lib.umicy.edu/libhome/Documents.center/legishis.html>>.

Library of Congress. *Copyright Law of the United States of America*. Copyright Office. Library of Congress <<http://lcweb.loc.gov/copyright/title17/#top>>. Also see the *THOMAS: Legislative Information on the Internet* at: <thomas.loc.gov/>. and the *U.S. Copyright Office* at <lcweb.loc.gov/copyright/>.

Louis-Jacques, Lyolette. *Listserv Lists*: These are Law Listservs at <<http://www.lib.uchicago.edu/~llou/lawlists/info.html>>.

Louisiana State University Libraries' U.S. Federal Government Agencies Page is at <<http://www.lib.lsu.edu/gov/fedgov.html>>.

National Association of State Information Resource Executives' State Search, is a topical links page to state agencies that is available at <<http://www.nasire.org/stateSearch>>.

National Initiative for a Networked Cultural Heritage is at <<http://www.ninch.org/#issues>>. NINCH is a non-profit organization that offers useful information on digital copyright legislation and intellectual property rights issues. Note: particularly check out their Basic Principles for Managing Intellectual Property in the Digital Environment, National Humanities Alliance of March 24, 1997, at <<http://www.ninch.org/#issues>>.

Online Legal Guidebooks and Directories available include Martindale-Hubbell at <<http://www.martindale.com>> and West's Legal Directory at: <<http://www.wld.com>>

Piper Resources' State and Local Government Resources on the Net features extensive links to state agencies on the Web at <<http://www.piperinfo.com/state/states.html>>.

Regulation Home Page at <<http://www.regulation.org>> features a guide to information, statistics, and studies on regulations

Rights and Reproductions Information Network taskforce of the Registrars Committee - a Standing Professional Committee of the American Association of Museums. <http://www.panix.com/~squigle/rarin/01rcsite.html>

Stanford University's Copyright and Fair Use Site at <<http://fairuse.stanford.edu>> is Stanford's Web site offering guidance on copyright including laws, opinions, and links to other sites.

State Court Decisions at American Law Sources Online (ALSO) is at < <http://www.lawsource.com/also> > and < <http://www.wolfenet.com/~dhillis/caselink.htm> > .

State Legislative:

State Legislative Comparisons in chart format is at < <http://www.multistate.com/weblist.htm> > .

State Statutes and Legislation is at < <http://www.prairienet.org/~scruffy/f.htm> > . (Full text)

University of Pennsylvania's Drafts of Uniform and Model State Acts is at

< <http://www.law.upenn.edu/bll/ulc/ulc.htm> > .

THOMAS at < <http://thomas.loc.gov> > is a Library of Congress Web site with summaries and text of new bills and statutes. This is also one of the best places to put together a legislative history.

UNESCO, Collection of National Copyright Laws. http://portal.unesco.org/culture/en/ev.php-URL_ID=14076&URL_DO=DO_TOPIC&URL_SECTION=201.html

United States Code (at U.S. House of Representatives Law Library) is available at

< <http://uscode.house.gov/usc.htm> > . Also available from Cornell at the Legal Information Institute at

< <http://www4.law.cornell.edu/uscode> > .

U.S. Copyright Office is at < <http://lcweb.loc.gov/copyright> > . This useful site provides guidance on copyright including registration forms, overviews and summaries, and full text of the laws, plus the ever *useful Copyright Office Information Circulars and Form Letters*, available at < <http://www.loc.gov/copyright/circs/> > .

United States Federal Court Decisions and Appeals may be found at:

< <http://www.law.vill.edu/Fed-Ct/fedcourt.html> > . (This is from Villanova's Center for Law & Information Policy.)

< <http://www.law.emory.edu/FEDCTS> > . (This is the Federal Courts Finder at Emory Law School, which connects to individual U.S. Courts of Appeals.)

U.S. House of Representatives Internet Law Library is online at < <http://law.house.gov> > .

U.S. Patent and Trademark Office is at < <http://www.uspto.gov/> > . See *Basic Facts about Registering a Trademark* at < <http://www.uspto.gov/web/offices/tac/doc/basic/> > .

United States Supreme Court Cases and Arguments may be found at the following Web sites:

< <http://www.findlaw.com/cascode/supreme.html> >

< <http://www.law.vill.edu/Fed-Ct/sct.html> >

< <http://www.fedworld.gov/supcourt> >

< <http://supct.law.cornell.edu/supct> >

< <http://oyez.nwu.edu> >

University of California at Berkeley's Copyright, Intellectual Property Rights, and Licensing Issues Section of the Berkeley Digital Library is at < <http://sunsite.berkeley.edu/Copyright/> > .

University of Michigan's guide to preparing United States Congress Legislative Histories is at

< <http://www.lib.umich.edu/libhome/Documents.center/legishis.html> > .

University of Michigan Documents Center for locating government documents is online at

< <http://www.lib.umich.edu/libhome/Documents.center> > .

University of Pennsylvania's Drafts of Uniform and Model Acts is at < <http://www.law.upenn.edu/bll/ulc/ulc.htm> > .

University of Texas Copyright Crash Course is at < <http://www.utsystem.edu/ogc/intellectualproperty/cprtindx.htm> > .

University of Virginia Library's Government Information Resources at <<http://www.lib.virginia.edu/govdocs>> is a guide to government documents.

Volunteer Lawyers for the Arts is at <<http://www.artlaw.org>>

Washburn University's WashLaw is at <<http://washlaw.edu>> is another good gateway site for legal information.

World Intellectual Property Organization (WIPO) is at <<http://www.wipo.org/>> .

WWW Virtual Law Library at <<http://www.law.indiana.edu/law/v-lib/lawindex.html>> is an excellent gateway to legal information of all sorts.

Yale University Library. *How to Find Government Information*, a topical guide to government documents, is online at <<http://www.library.yale.edu/govdocs/govdoc.html>> . Also see *LibLicense: Licensing Digital Information* at <<http://www.library.yale.edu/~llicense/index.shtml>> .

Zorich, Diane *A Survey of Digital Cultural Heritage Initiatives and Their Sustainability Concerns*. Washington, D.C.: Council on Library and Information Resources, 2003.

A Museum Guide to Copyright and Trademark. American Association of Museums. 1999

Developing Intellectual Property Policies: A Guide for Museums, Canadian Heritage Information Network/National Initiative for a Networked Cultural Heritage

Chapter 3: Publications

	<u>Page</u>
A. Overview	3:1
What is a publication?	3:1
What kinds of publications use museum collections?	3:1
How does the park benefit by using museum collections in publications?	3:2
Where can I find additional information on developing publications?	3:3
B. Legal Issues Specific to Publications Using Museum Collections	3:4
C. User Requirements	3:4
What NPS policies and procedures must a researcher and publisher agree to follow when using NPS museum collections in a publication?	3:4
What are the elements of a credit line and when must they appear?	3:4
How do I ensure the researcher gives the park publication copies?	3:5
What is a park-specific rights and reproduction policy?	3:5
How do I prepare a park-specific rights and reproduction policy?	3:6
What duplication and copying procedures apply?	3:7
What credentials must the user have to use the park's collections in a publication?	3:8
D. Documentation	3:8
How do I document objects used in a publication?	3:8
What is an exclusive use agreement?	3:8
Should I agree to an exclusive use agreement?	3:8
What is licensing?	3:8
Who can publish using NPS museum resources?	3:9
E. General Information on Producing a Publication	3:9
What is the purpose of the publication?	3:9
Who is involved in developing a publication?	3:10
How do I decide which media or format to use?	3:11
What are the advantages and disadvantages of each publications format?	3:12
How do I determine publication specifications?	3:14
What are the basic steps in the publication process?	3:17
How do I identify the audience?	3:17
How do I plan and develop a theme?	3:19
What do I include in writing a formal publication proposal?	3:20
Where do I find funding?	3:22
How do I find partnerships and why is it desirable to have them?	3:22
Why would I consider a partnership?	3:23
What should I do to prepare a publication?	3:24
When do I begin writing text?	3:27
What does a writer do?	3:27
What are the steps in selecting content?	3:29
How do I obtain licenses and permissions?	3:30
What do I need to know about writing captions?	3:31
When do I begin review and final fact-checking?	3:32
What do I need to know about editing?	3:32

Page

What do I need to know about design and layout?.....	3:34
How do I work with a professional designer?	3:35
Should I produce a camera-ready copy or an electronic manuscript?.....	3:36
How do I obtain illustrations for my publication?	3:36
F. Producing Paper Media	3:36
What do I need to know to select the best kind of paper publication for my purpose?	3:36
How do I plan and develop a brochure?.....	3:37
How do I plan and develop a journal article or an entire journal issue?	3:39
How do I plan and develop a monograph?	3:41
What do I receive from the editor and how do I respond?.....	3:46
What other work must I provide?.....	3:47
How do I plan and develop a catalog?.....	3:47
Should I use permanent paper?	3:49
G. Producing Moving Images	3:49
What types of moving images media are there?.....	3:49
How do I plan to make a film or video?	3:51
What resources will I need?	3:51
What are the advantages and disadvantages of these formats?.....	3:51
When is it appropriate to produce a video in-house?.....	3:53
When is it appropriate to work with a professional?	3:54
How do I select a film or video maker?	3:54
How do I negotiate with a film or video maker?.....	3:54
What are the steps involved in production of a film or video?.....	3:54
What is the Harpers Ferry Center - Audiovisual Division (HFC-AV)?.....	3:55
H. Producing Multimedia	3:55
What types of multimedia publications exist?.....	3:55
How do I plan and develop multimedia publications?.....	3:55
What resources will I need?	3:56
What is the vocabulary of multimedia?	3:56
What are the advantages and disadvantages of these multimedia formats?.....	3:56
When is it appropriate to produce a Web page or CD-ROM in house?.....	3:58
What do I need to know to produce a museum collections Web site?	3:59
How do I produce a museum collections Web site?.....	3:59
What do I need to know to produce a CD-ROM?	3:59
How do I produce a CD-ROM?.....	3:59
What is an online order fulfillment service?	3:59
How do I negotiate with potential order fulfillment services and multimedia publishers?	3:60
How do I select a multimedia publisher or producer?	3:60
I. Producing Sound Recordings	3:60
How do I plan and develop a sound recording?.....	3:60
What resources will I need?	3:61
What are the major types of audio formats?.....	3:62
What are the advantages and disadvantages of these formats?.....	3:62
When is it appropriate to produce a sound recording in-house?	3:64
When can I use historic recordings or instruments?.....	3:64
What must I do to locate a good sound publisher?	3:65

Page

J. Identifying and Developing Special Skills	3:65
What skills are required to produce sound and multimedia publications?.....	3:65
How do I learn to produce NPS publications?.....	3:65
What do I look for when reviewing resumes and portfolios of non-NPS publication contractors?	3:66
How do I contract or partner?	3:66
What is a scope of work?	3:66
What is a contract?.....	3:66
Who handles bids?	3:66
How do I market my publications?	3:67
K. Annotated Selected Bibliography	3:68
L. List of Figures	3:71

CHAPTER 3: PUBLICATIONS

A. Overview

1. *What is a publication?*

A publication is information distributed to the public through communications media, including:

- books (monographs, biographies, reference works, bound collection catalogs, exhibition catalogs, coffee table books, and similar works)
- articles in journals or newspapers
- pamphlets (site bulletins, fliers, brochures, or special handouts)
- archival finding aids such as repository-level guides, indices, databases mounted on the Web, or folder lists
- motion picture films, filmstrips, and commercial programmatic videotapes
- sound recordings
- research reports
- published slide show packages and mass-distributed portfolios of prints and photographs
- CD-ROMs containing software, games, and virtual museum tours
- Internet sites such as the World Wide Web

For a glossary of terms used in this chapter, refer to *Museum Handbook*, Part III (*MH-III*), Appendix A.

2. *What kinds of publications use museum collections?*

Many kinds of publications may use NPS museum collections including:

- Educational publications:
 - textbooks
 - curricula and lesson plans
 - long-distance learning courses that stay online after completion
 - NPS films and educational videos
 - interpretive publications
 - World Wide Web and other Internet publications
 - CD-ROM educational packages

- Scholarly publications:
 - books (scholarly studies incorporating elements from natural history and cultural resources collections and archival images)
 - periodicals
 - museum exhibition catalogs
 - museum collection catalogs
 - catalog raisonnés (complete in-depth listing and analysis of all works by an artist or school of artists)
 - union catalogs (a collection catalog that documents the collections of multiple repositories or parks, such as all park museum collections in the Midwest)
 - archival and manuscript-finding aids
 - research reports
- Popular publications:
 - heritage tourism, heritage education and travel books
 - popular survey volumes on a variety of topics
 - television programs
 - Web and other Internet pages
- Administrative publications:
 - General Management Plans
 - Collections Management Plans
 - Administrative Histories
 - reports of various kinds

3. *How does the park benefit by using museum collections in publications?*

The park benefits by:

- allowing the public, staff, and scholars to see our collections, often for the first time, since less than 1% of our museum holdings are exhibited at any given time
- enriching heritage education and tourism

- providing physical evidence of the past for scholarly study, allowing parks to obtain new interpretations, understandings, and knowledge based on their natural history, ecosystems, history, and material culture resources
- allowing access to information on NPS collections without physical risk to the collection
- attracting significant outside researchers, institutions, and publishers to NPS resources for future collaborative projects in education and interpretation
- enhancing park and center visibility and developing a strong national and international community of park advocates who care about preserving NPS resources and making them accessible
- capturing in print a snapshot of park resources for future use as baseline data and research resources and to document and mitigate changes in the resources
- illustrating why NPS requires funding to preserve and make accessible these collections

4. *Where can I find additional information on developing publications?*

- Take courses at your local college in:
 - research methodology
 - writing
 - editing
 - design and layout
 - desktop publishing
 - indexing
- Search the World Wide Web writing sites posted on the curatorial bulletin board on cc:Mail or via a search engine.
- Borrow or buy books on the subject.
- Talk to other NPS staff who prepare publications, for example, the editors of NPS journals, such as *CRM* and *Common Ground*, and the DOI newspaper *People, Land, and Water*.
- Talk to cooperating association staff who work on publications.
- Work with Harpers Ferry Center and Denver Service Center's Publication Office and your park or regional printing coordinator.

- Form a partnership or develop a cooperative agreement with a local publications expert, such as a university press or other museum publication staff.
- Hire and work alongside a qualified contractor

M. Legal Issues Specific to Publications Using Museum Collections

The laws affecting publications using museum collections include copyright, the Freedom of Information Act, privacy legislation, publicity legislation, obscenity legislation, and laws on historic resources, endangered cave resources, and archeological resources preservation. This legislation is described in *MH-III*, Chapter 2, Legal Issues.

N. User Requirements

1. *What NPS policies and procedures must a researcher and publisher agree to follow when using NPS museum collections in a publication?*

Researchers must complete researcher registration forms, copyright and privacy statements, and researcher duplication forms described in *MH-III*, Chapter 1, Evaluating and Documenting Museum Collections Use, Section H, User Qualifications. Also see *MH-II*, Appendix D, Museum Archives and Manuscript Collections, Figures D.13-18 for sample forms. *MH-III*, Chapter 1, Section I, Documentation, provides more information.

As a publisher, you must:

- follow NPS policies and guidelines relating to publications
- work with your printing coordinator
- understand and follow the procedures suggested in this chapter

In accordance with the Government Printing and Binding Regulations (USC, Title 44, Section 501), the Government Printing Office (GPO) prints federally funded work. If you're using government funds to produce a paper (hard copy) publication, work with your regional printing coordinator.

2. *What are the elements of a credit line and when must they appear?*

NPS procedures require that researchers cite a NPS format credit line in all published captions, references, quotation citations, bibliographies, and footnotes that use NPS collections, regardless of format (Web, paper, sound recording, or moving images). Researchers and publishers must cite the following elements in a NPS format credit line:

- National Park Service
 - park or center name
 - object or collection title or description (for archives, also include box number and folder title or number)
-

- control number, such as a catalog or negative number (to help others order copies when they see the item reproduced in the publication)
- credit to the original creator of the item (the original artist, writer, photographer, or scientific collector)

For example, “Courtesy of National Park Service, Yellowstone National Park, Thomas Moran, “Sand in the Canyon,” 1871, YELL 8542”

Note: For some visual artists, particularly fine artists and photographers, this credit line is required as part of copyright protection.

Use the Department of the Interior buffalo seal and NPS arrowhead logo on all printed material paid for with government funds. If you use more than one color in any printed publication, you need approval from the Washington Office printing officer. You may make your printed publications available for sale through GPO by submitting a GPO Form 3868, Notification of Intent to Publish. This form is available from your regional printing coordinator or the Washington Office printing officer.

3. *How do I ensure the researcher gives the park publication copies?*

When the researcher first registers, ask for at least two copies of any publication produced using park collections. Restate that request when the researcher requests copy photographs. Within 10 days of publication, ask the researcher to give copies to the park. Explain that the park maintains copies of works based on park collections, and lists those publications on the NPS Museum Management Program (MMP) Web site.

Place your request for publication copies of works produced using park collections on your park's researcher registration or duplication forms, so the researcher understands this from the minute of registration. You should request a small publications budget to buy works based on your park's collection.

You or the park librarian should send full bibliographic citations of the received publications to the Museum Management Program (MMP), National Center for Cultural Resources Stewardship and Partnership Programs, to have the publication listed on the Web site.

4. *What is a park-specific rights and reproduction policy?*

A park's rights and reproductions policy must cover the following issues:

- the purpose of giving researchers copies, usually to enhance access and use of collections under the fair use provisions of copyright laws (See *MH-III*, Chapter 2, Legal Issues.)
- procedures for obtaining copies and for payment
- the park's fee schedule for copies, including supplementary fees for rush orders and other special projects
- policies on when visitors may use their own equipment to make copies, and how requests are made and considered

- procedures for collecting, managing, and using fees collected
- definition of terms used in the policy, such as rush job, fair use, indemnification, and oversize
- procedures for requesting and obtaining publishing permissions, rights clearances, and licenses
- acknowledgment (crediting and captioning) procedures
- how and when park and NPS logos and names may be used
- pre-publication review procedures
- how to request reproductions or copying permission for loaned materials

See Figure 3.5 for a sample cooperative publishing agreement, Figures 3.6 and 3.7 for sample model release forms, and Figure 3.12 for a sample Memorandum of Agreement for a publication.

5. *How do I prepare a park-specific rights and reproduction policy?*

Park rights and reproductions policies will vary considerably, depending on a park's circumstances, such as its ability to collect reproduction fees and the level of staffing to handle duplication or copy order work involved in reproductions.

Work with your cooperating association or have memoranda of agreement with private companies for large projects to recover costs involved in producing copies, captions, derivative works, and publications. These sources may be used to cover the staff salaries and user costs associated with a publication project.

To develop a rights and reproduction policy, work with a team of staff including:

- curators
- archivists
- registrars
- librarians
- discipline specialists
- budget officers
- contracting officers
- public affairs officers
- cooperating association staff

- NPS solicitors
- associated groups, as appropriate

Use this team to develop a working draft for review by the NPS solicitor and the superintendent. For more information see *MH-III*, Chapter 4, Reproductions (in prep.).

6. *What duplication and copying procedures apply?*

If the researcher wishes to have xerographic, photographic, microfilm, or digital copies produced of the park's museum objects, you should:

- follow the park-specific rights and reproductions policy (developed **before** materials are copied and given to the researcher)
- ensure researchers fill out the researcher registration form, the access and use policy statement, the researcher duplication form, and the copyright and privacy restriction statement **before** they obtain copies
- make certain that on the researcher forms or on the researcher's equivalent task directive statement, if the researcher is conducting a park-supported research project, the researcher has indicated precisely how the copied materials will be used (for example, one-time internal use of the image within chapter 6, page 56, of the second edition of the book as a full-page spread, sized 6" x 9" with caption)
- don't allow researchers to make their own copies because they may damage original materials or unknowingly infringe copyright or privacy or publicity restrictions
- ask researchers to identify items they wish to copy by writing an accurate description on the researcher duplication form; if the research is archival, the researcher should use an acid-free strip of paper (no post-it notes or sticky tabs) so it is clear where the item is located
- ensure the researcher knows he or she is responsible for securing any necessary third-party permissions, such as copyrights, privacy or publicity rights, consultations, etc., with traditionally associated groups for sensitive cultural materials; the NPS reserves the right to demand proof of receipt of such permissions before providing copies (See Section D on Cultural Issues for further guidance.)
- determine if the copy will be used in product development, such as reproducing a piece of furniture for sale, or developing a multimedia product with a significant portion (5%+) of NPS-provided content; if so, follow the guidance provided in that section of Chapter 4, Reproductions (in prep.)

If you have preservation or record copies (such as record photographs, digital files, xerographic copies, or reproductions) of your objects, provide these materials to the researcher instead of the original object.

7. *What credentials must the user have to use the park's collections in a publication?*

See *MH-III*, Chapter 1, Section H, User Qualifications.

O. Documentation

1. *How do I document objects used in a publication?*

Note when materials have been published in the catalog record and accession folder. Place a photocopy of the title page of the publication and the page(s) that show the object in the accession folder, and if available, the catalog folder.

Consider creating a publications notebook(s), organized by catalog numbers in increasing numerical order, with tabs by year, to hold the pages and any notes or copies of the researcher registration form you wish to keep together to document collections usage. Use the citation screen in ANCS+ to record this information on particular works.

Ask researchers for copies of publications using park collections. Keep one copy in the museum archives and others in the park library.

2. *What is an exclusive use agreement?*

On occasion, publishers, authors, or multimedia distributors will request an exclusive use agreement. This agreement states that the park will not provide copies of the research materials to any other publisher, author, or multimedia distributor for publication, use, or distribution. The details of the contracts can vary significantly from publisher to publisher.

NPS staff may NOT sign exclusive use agreements for NPS-produced or owned archival and manuscript collections because most materials are available by law to all.

3. *Should I agree to an exclusive use agreement?*

No. The NPS collections are held in trust for the American people, not for just a single user. Agreements benefiting one organization or group at the expense of others are questionable at best. According to the NPS policy of equal access, any materials supplied to one publisher also must be supplied to any other requesting publisher. See *MH-III*, Chapter 1, Section C, Ethical Issues.

4. *What is licensing?*

Licensing is a written or contractual agreement allowing an organization or individual to use materials in a certain way or in a certain geographic area during a given period of time and after providing royalties. Licensing implies that something is being given to one group and denied from other groups. NPS may *not* grant exclusive or sole use of (i.e., license) our public collections to one group. The NPS has no authority to license products. Though the NPS can't license or authorize exclusive use, agreements are possible. See Figure 3.5 for a sample agreement.

5. *Who can publish using NPS museum resources?*

Anyone who follows the NPS policies and procedures for access, researcher registration, duplication, and the copyright and privacy statement and their related laws may publish NPS objects.

NPS provides equal access to all unrestricted materials, though such access is regulated by the park's specific policies on access and use and rights and reproduction policies. Access, use, and duplication may be limited to specific times because of limited park resources, particularly staffing.

Many publications relying on NPS collections for illustrations or research are written by non-NPS researchers and authors. Publishers of park resources might include park archeologists, curators, archivists, interpreters, research scientists, and cultural and natural resource managers. Users who publish might be reporters, researchers, scholars, students, or writers.

Another major community of users is made up of cooperating associations; park concessionaires; partners, such as museums; local school districts; universities; historical societies; and other organizations. The Parks as Classrooms program is one example of a cooperative venture. Cooperating associations are the foremost publishers of park-related materials. For a list of cooperating associations, write to:

Conference of National Park Cooperating Associations
PO Box 640
Charles Town, WV 25414

The NPS doesn't limit the right to publish NPS museum objects to staff or to a few individuals. Anyone who follows NPS policies and procedures may publish using NPS collections.

P. General Information on Producing a Publication

1. *What is the purpose of the publication?*

Before beginning a publication, it is essential to identify the purpose of the publication:

- Who is the audience to be reached?
 - What is the message to be conveyed?
 - What is the publication's purpose?
 - What publication format and media best reach the audience? See the chart in Question 4 for a summary of the advantages and disadvantages of:
 - paper publications (books, pamphlets, image portfolios, document packages, journals)
 - moving image publications (video and film)
-

- multimedia publications (CD-ROMs and Internet sites such as the World Wide Web)
- sound recording publications (CD-ROMs, cassette tapes, Web radio programs, and oral histories)
- Is the project realistic, considering:
 - the park's museum collections and its strengths and weaknesses?
 - the park staff and partner's publication skills in writing, editing, designing, layout, and their topical expertise?
 - park staff and partner's available time, budget, and other resources?

2. *Who is involved in developing a publication?*

Producing a publication involves various skills and talents that may be found in one or two people, or among internal and external staff, including partners, contractors, and publishing professionals.

The necessary skills for producing a publication include planning, researching, interviewing (may not be required), writing, editing, consulting with others, designing, and project managing. The needed skills vary depending on the type of publication.

For a CD-ROM or Web site, the emphasis is on writing, producing a storyboard, design and layout, and establishing the work flow (linkages). For moving images such as video, the emphasis is on producing a storyboard, identifying locations, preparing actors and locations for filming, editing, and obtaining permissions. For sound publications, the needed skills are for selecting a program and performers, hiring a performance locale or professional sound studio and crew, mixing elements, and marketing.

Internal participants might have any or all of the above skills. These include:

- discipline specialists such as park, center, or SO museum staff, archeologists, biologists, paleontologists, ethnographers, historians, archivists, librarians, and interpreters
- public affairs officers
- printing coordinators
- Support Office (SO) staff
- Harpers Ferry Center staff for exhibitions, publications, film, sound recordings, and videotapes
- Denver Service Center staff
- National Center staff

Regardless of the people involved, one person must be the responsible project manager who oversees the production from planning and proposal to marketing the final piece. This person must have a sound understanding of publishing and good managerial skills.

Any of the required skills can be contracted or obtained from a partner. External participants include NPS partners such as cooperating associations, the National Park Foundation staff, and local universities or schools.

If you work with a publishing house, such as a University Press or the GPO, you probably will be expected to submit a manuscript in electronic form. You may be asked to code the manuscript electronically, or to produce formatted electronic final pages (mechanicals). If you are working with a contracting sound or video publisher, you may be asked to develop a storyboard, script, or program.

The publisher may do some of the production for you, such as layout and design, editing, indexing, and marketing. The amount of work done by the publishing firm depends on the contract you negotiate with them.

3. *How do I decide which media or format to use?*

Before you select a publications format, identify your audience, message, and the purpose of your publication. Learn the advantages and disadvantages of the different publications formats as a tool to reach your specific audience.

Each medium or publications format reaches different audiences. A quick summary of these audiences, by format follows:

- **Paper publications** are used in every home, school, library, office, and organization around the country, although getting a publication to all of these venues can be expensive.
- **Moving images** reach people largely through television, although many schools and theaters also show moving images directly. Growth areas for moving images include CD-ROMs, videotape screenings on commercial aircraft flights, and public library circulation of videotapes and CD-ROMs.

Sold through catalogs and stores, video is marketed, played, and used for education worldwide in various formats, from Beta and VHS, to the PAL system (used in England). Digital Versatile Discs (DVDs), a new CD-ROM format, hold entire commercial motion pictures on one CD.

- **Multimedia (Web and CD-ROM)** reach more than 40 million individuals and institutions worldwide through the Internet and the World Wide Web. Individual CD-ROMs are marketed like books, although they can contain text, sound files, still and moving images, or software. Most computers being sold contain CD-ROM drives and an increasing number are reaching American schools.

The global market for CDs and quantities of freeware CDs is growing proportionally. See *COG 19/19, Care of Archival Compact Discs* for background information on CD technologies.

- ***Sound recordings*** reach most households, schools, libraries, offices, and organizations around the country. The most popular sound recording form is CD. The new Web Radio format and online sound files on the Web are making sound recordings more widely available than ever before.

4. *What are the advantages and disadvantages of each publications format?*

See the following chart.

Publication Formats Summary Chart		
Type of Media	Advantages	Disadvantages
<p>Paper (Books, Pamphlets, Journals, Image Portfolios, Document Packages)</p>	<ul style="list-style-type: none"> • Familiar and comfortable • Portable and easily shipped via the post office, fax, or by other carriers such as UPS • Easy to use, requires no special playback equipment • Can last for 100+ years if prepared to preservation standards • Is 16 times less expensive than magnetic or electronic media to store because it doesn't need refreshing, migration, software, and equipment maintenance • Used widely in the home, schools, and public libraries • Included in all information distribution systems for education, research (abstracting and indexing), and documentation (accessioning and cataloging) worldwide 	<ul style="list-style-type: none"> • Can be seen as old fashioned • Expensive to distribute and bulky to carry • Expensive to print, so fewer copies are made and reach fewer people initially • If wood pulp, can deteriorate fast, reaching fewer people over time • Cumbersome to update, as you must reprint it • Not interactive • Not a good learning medium for some students • Not easily searched like electronic records
<p>Moving Images</p>	<ul style="list-style-type: none"> • Available internationally via the Web and television • Popular • Attractive to hearing and sight • A widely used technology in schools, libraries, theaters, offices, homes and on airlines • Saleable in shops and catalogs worldwide • Effectively show action, time, and sequence • Have freeze-frame and rewind, so individual learners can review something they missed or didn't understand. • Used for self-paced learning for basic how-to skills 	<ul style="list-style-type: none"> • Are passive media that appeal to the senses of sight and sound • Can be expensive to produce • Easy to create a non-professional quality video; difficult and expensive to do a professional-quality product • Videotape is short-lived and requires refreshing and migration (reformatting); film is longer-lived media but requires excellent cold storage and usage copies • Requires equipment to play • The newer technology isn't always compatible with older technology, for example, VHS equipment doesn't play old Beta or PAL formats

Publication Formats Summary Chart

Type of Media	Advantages	Disadvantages
Multimedia (CD-ROM and Web)	<ul style="list-style-type: none"> • Popular internationally • Interactive and user-driven • Attractive to hearing, sight, and touch (virtual reality, the mouse); it can incorporate text, image, sound, and video files, and virtual reality experiences in real time • Allows for simulated learning situations • Effectively shows action, time, and sequence • Relatively inexpensive to produce • Easy and inexpensive to update and distribute • Reaches millions of users internationally • Engages users in self-paced learning with hypertext links, which allow users to explore peripheral areas of interest 	<ul style="list-style-type: none"> • Requires an excellent writer, editor, and graphic designer, and the multimedia abilities of a filmmaker, and specialized coding skills • CD technologies are fragile, change rapidly, and often can't play earlier CD formats • Modern Web access is not yet as universal as television • Not eye legible, requires equipment to use that must be maintained • Not all home systems can play sound, video, and image files • No single Web style manual; no equivalent to the <i>Chicago Manual of Style</i>
Sound Recordings	<ul style="list-style-type: none"> • Can be used on the radio, television, and on the Web, reaching millions easily • A very personalized, "real time" media that gives a sense of actually "being there" with a famous personality or performer • Can reach people that the written word does not reach effectively • Can be distributed as CD-ROMs cheaply and effectively 	<ul style="list-style-type: none"> • While Web radio is growing tremendously in popularity, not all home or office computer systems have speakers or sound cards to play sound files • Requires equipment that must be maintained • Technologies change quickly, and are not compatible with earlier formats

5. *How do I determine publication specifications?*

Before you write your publication specifications, decide whether the publication will be of permanent value to the NPS.

Permanently valuable publications might include:

- collections catalogs
- catalog raisonnés
- archival finding aids
- Internet (Web) features
- studies of park site elements (histories, archeological, natural resource and architectural studies)

Temporarily valuable publications might include:

- handouts of special events
- temporary leaflets
- special event posters of minor event

See the following chart for determining publication specifications.

How to Determine Appropriate Publication Specifications		
Type of Publication	If Permanent Select . . .	If Temporary Select. . . .
Books	<ul style="list-style-type: none"> • Permanent and durable paper (lignin-free, high alpha-cellulose paper with a pH between 7.5-8) as listed in American National Standards Institute (ANSI) standard for permanence of paper for printed library materials, P39.48-1984 • Carbon black or inorganic ink • Sewn, not glued hardcover binding for durability • Wide gutters (wide interior margins) so text isn't cropped if rebound 	<ul style="list-style-type: none"> • The least expensive paper allowed by NPS publications coordinator • Any ink • Any margins • A glued soft-cover binding for lowest cost
Journals	<ul style="list-style-type: none"> • Usually no choice as the publication material and format are determined by the editor and publisher; should be permanent and durable paper for special issues 	<ul style="list-style-type: none"> • The least expensive format; any paper or ink will do
Pamphlets	<ul style="list-style-type: none"> • Permanent and durable paper (lignin-free, high alpha-cellulose paper with a pH between 7.5-8) as listed in ANSI specification P39.48-1984 • Sewn, not stapled • Wide gutters (interior margins so text isn't cropped if rebound) • Carbon black or inorganic ink, not produced on a daisy wheel printer, ink jet printer, or with a thermograph or mimeograph (If printed from a computer, use laser jet printer; if xerographically copied, make certain the toner has fused.) 	<ul style="list-style-type: none"> • The least expensive format; any paper, ink, or format will do from hectograph, mimeograph, to daisy wheel printer on demand

How to Determine Appropriate Publication Specifications		
Type of Publication	If Permanent Select . . .	If Temporary Select. . . .
Image Portfolios	<ul style="list-style-type: none"> • Permanent and durable paper folder or photographic paper (lignin-free, high alpha-cellulose paper with a pH between 7.5-8) as listed in ANSI specification P39.48-1984 • Images processed according to ANSI standards if photographic • Images tested for residual thiosulfate and density • Sewn (if bound), not stapled • Wide gutters (interior margins so images aren't cropped if rebound) • Carbon black or inorganic ink if printed 	<ul style="list-style-type: none"> • The least expensive format—any paper, ink, or binding, even short-lived color photography or xero-graphic processes
Document Portfolios	<ul style="list-style-type: none"> • Permanent and durable paper folder and document paper (lignin-free, high alpha-cellulose paper with a pH between 7.5-8) as listed in ANSI specification P39.48-1984 • Sewn (if bound), not stapled • Wide gutters (interior margins) so images aren't cropped if rebound • Carbon black or inorganic inks or pigments (not dyes) if printed 	<ul style="list-style-type: none"> • The least expensive format
Moving Image-Motion Pictures	<ul style="list-style-type: none"> • Film processed to ANSI standards • Film tested for residual thiosulfate, resolution, and density • Film issued in archival film cans such as polyester • Archival quality tape leader and splices to prevent film sticking and tape ooze 	<ul style="list-style-type: none"> • The least expensive format—probably videotape
Moving Image Videotape and Sound Recordings-Cassettes and Reel-to-Reel	<ul style="list-style-type: none"> • PET or Mylar tapes that are short-playing (less than 30 minutes); they are stronger • Tapes with iron oxide pigments, not metal particulate or chromium dioxide pigments • Reel-to-reel format for master copies; short-playing thick tape cassettes (not long-playing) for viewing copies • An inert plastic (such as polyester) film reel container 	<ul style="list-style-type: none"> • The least expensive format—probably long-playing videotape in a microcassette format
Moving Image Digital Versatile Disc (DVD) and Sound Recordings	<ul style="list-style-type: none"> • A more tested media; no permanence data available yet for DVD and sound recordings 	<ul style="list-style-type: none"> • DVD

How to Determine Appropriate Publication Specifications		
Type of Publication	If Permanent Select . . .	If Temporary Select. . . .
Moving Image Laser Disc	<ul style="list-style-type: none"> • A disc that has a stable external layer (such as gold), stable pigments, and an inert plastic or etched glass substrate • A scratch resistant disc 	<ul style="list-style-type: none"> • The least expensive format
Multimedia-Diskettes	<ul style="list-style-type: none"> • Diskettes, but realize they are short-lived • Reel-to-reel tapes, as your master; short-playing thick tape cartridges for usage and sales 	<ul style="list-style-type: none"> • The least expensive format
Multimedia CD-ROMs and Sound recordings-CD-ROMs	<ul style="list-style-type: none"> • A scratch-resistant disc with a gold layer, thalocyanine dye, and an inert plastic or etched glass substrate, <i>not</i> an aluminum reflective layer or substrate • An Error Detection and Correction (EDAC) format disc • Polystyrene jewel cases with an internal tray and hub to hold CD in place for distribution and storage • An ink-printed paper label under the jewel case tray for reading through the clear jewel case cover, instead of printing directly on the CD 	<ul style="list-style-type: none"> • The least expensive format

6. *What are the basic steps in the publication process?*

The basic steps necessary to all types of publications include:

- identifying your audience
- planning and developing your theme
- writing a publication proposal
- finding funding

7. *How do I identify the audience?*

Determine the purpose or function of your publication. Ask yourself why you want to produce this publication. For example, are you preparing something to:

- attract the attention of scholars to your collections?
- aid in park interpretation?
- be used in the school curricula by teachers? If so, at what level?
- interest the public in museum collections by showcasing them thematically in catalogs or exhibits?

Ask yourself how:

- the publication will serve the NPS's mission
- the publication will help the park
- the publication will serve your discipline/profession
- the publication features NPS museum collections
- the publication differs from others on the topic

What is the age group of the potential audience? The Library of Congress National Digital Library has published a report prepared by the Center for Children and Technology (available at cct@edc.org) called *Collection Evaluation Criteria*, which identifies key thinking skills for history, culture, English language, literature, science and technology, and social sciences, such as:

- comprehension
- analysis and comparison
- research
- interpretation
- decision-making
- applying these skills to real-life examples

If you are planning to produce an educational publication, you might find it helpful to understand what level of skills your audience will have. For further information on this publication, look at the Library of Congress Web site at <http://www.loc.gov> to see how it handles these educational issues.

Another useful Web homepage is Federal Resources for Educational Excellence (FREE) located at <http://www.ed.gov/free/>. This site provides a compilation of excellent educational materials produced by federal agencies, including the NPS. It is searchable by subjects, such as "social sciences" or "arts."

As you develop a Web site or feature, plan to put it on the NPS server under your park, office, or center. There is very useful guidance and policy on creating NPS Web pages at <http://www.nps.gov/helpdesk/>. In order to make your Web site available to the widest audience, please inform the Cultural Resources Web team leader, National Center, Cultural Resources Stewardship and Partnership via cc:Mail at CR Web_Team. Appropriate links will be set up from the "Links to the Past" homepage at <http://www.cr.nps.gov/>, especially under "Tools for Teachers."

Some software packages have built-in language assessment features that determine the grade-level of your publication's vocabulary.

Know what geographic population you wish to reach. Some publication formats, such as television and the World Wide Web, are international, while others don't reach most homes. Use television to reach the most households in the United States and video or paper to reach the most schools.

Know your audience's disciplines and professions and the publications and research trends in which they are interested. Learn the demographics of the gender and other socioeconomic factors of your audience, as not all media reach all groups equally. For example, the Web reaches more men than women, although this is rapidly changing.

8. *How do I plan and develop a theme?*

The following steps, taken in sequence, should help you develop the purpose and scope of your theme.

- ***Don't work in a vacuum.*** Involve expert, discipline-specific professionals in all stages of the project from researching, writing, and editing, to peer review. This group becomes the project team.
- ***Develop expertise.*** Read widely on the topic area so you know the current standards of scholarship. Ensure your project team has no gaps in expertise.
- ***Establish project evaluation criteria.*** Have the team establish criteria for evaluating the publication before they begin work.
- ***Identify traditionally associated groups concerned about this topic.*** Identify the issues of concern, then produce a bulleted list of the major questions to be answered in the publication. Avoid stereotypes and assumptions. See *MH-III*, Chapter 1, Section D, Cultural Issues.
- ***Avoid conflicts of interest in your participants.*** Avoid asking an employee of a major corporation to serve on your project team if the publication will compete with the employee's corporate products.
- ***Determine the project depth or level of investigation.*** As described in the Cultural Resource Management Guideline (formerly NPS 28), Chapter 2, Research:
 - ***an exhaustive project*** might include exhausting all original documentary sources, making physical comparisons with similar objects, and sampling and testing fabric for identification, dating, and circumstantial evidence
 - ***a thorough project*** is more selective, using readily available documentation and includes a comparison of similar objects
 - ***a limited project*** checks easily located, relevant documentation and compares a few similar objects

- **Focus your topic.** Don't try to cover too much. Use time and geography to limit your topic. Writing a publication on the Civil War may be too immense for your park. Try writing on a Civil War action in a particular area during a particular time. Focusing your topic gives you an achievable goal. Unfocused publications tend never to be completed.

The most common mistake of first-time publishers and writers is to pick a topic that is too large or unfocused.

- **Be comprehensive.** Once you have focused your topic, answer the questions who, what, where, why, when, and how about it. Write a paragraph or two summarizing the publication. Cover your topic systematically without leaving any major gaps.
- **Ensure the topic works when applied to museum collections.** Is the topic applicable to the materials you wish to include? Does the topic work as an examination of material culture? If not, rewrite the message.
- **Get a peer review.** Send the summary paragraph, issues list, and criteria to a peer review panel that includes related discipline specialists. Identify the issues of concern to all traditionally associated groups.
- **Incorporate the review comments.** Then revise and update the summary paragraph, issues list, outline, and criteria for evaluation, as necessary.
- **Produce an outline for the publication.** Break the outline into chapters or sections and detail the content of each chapter or section. Send the outline for another peer review that includes discipline specialists.
- **Meet with the project team.** Determine who will write the sample publication section (such as a book chapter); finalize the outline, timeline, and budget; and develop the book specifications.

9. *What do I include in writing a formal publication proposal?*

You should prepare:

- a summary paragraph overview of the publication
- a purpose statement
- a description of the publication's audience and the publication's benefits to that audience
- an outline of the publication including the major questions you will be investigating or covering and:
 - a table of contents

- a brief description of each chapter or primary section of a Web site
- the name and curriculum vitae of the author(s) and editor(s)
- lists of the elements to be found in the front matter (such as table of contents, acknowledgments, frontispieces, etc.)
- lists of elements to be found in the back matter (such as indices, bibliographies, footnotes, illustrations)
- specifications including:
 - publication content
 - size in characters, pages, and publication format size
 - format and type (for example, book specifications might include the number and type of illustrations, whether cloth or paperback, size of printing edition in number of copies, front- and back-matter details, and the proposed retail price)
- a timetable with the names of all parties responsible for each section
- *Management Policy* requirements for research (cited in Chapter 5:3, December 1988):
 - the relationship of the research to the management objectives
 - the project’s theoretical orientation and methodology
 - how data will be recorded
 - how confidentiality will be preserved
 - how the results will be disseminated
 - how the resulting research documentation will be preserved
 - how the publication and research documentation will be made available in the future
- a list of participants, partners, and supporters and their resumes
- a budget (consider getting an estimate from the GPO)
- a sample section, such as a chapter or essay, to evaluate the quality of the research and writing, required by some publishers

10. *Where do I find funding?*

Various funding sources, both internal and external, are available for NPS publications, including:

- park cooperating associations, which can apply for and receive federal funding for publication projects for the park
- National Park Foundation
- National Center for Technology and Training publications grants
- university presses, which might publish NPS manuscripts at no charge if they can profit (See the bibliography for source lists of publishers.)
- professional or popular periodicals or existing scheduled NPS publications, such as *CRM*
- foundations (See Figure 3.13 for a list of foundations that fund such publications and the bibliography for a list of appropriate source books on foundations.)

Note: You may use commercial and university presses only when working with a cooperator. Generally speaking, you must publish federally produced work through GPO.

11. *How do I find partnerships and why is it desirable to have them?*

If you are raising outside funds, consider your cooperating association, the National Park Foundation, and collaborative partnerships with private publishers, such as university presses or professional organizations. Evaluate local and regional universities, foundations, and publishing houses that have a history of publishing on the topic you wish to document.

- ***To find a suitable publisher:***
 - Ask a discipline specialist for a list of the best presses publishing this topic.
 - Call the reference desk at your closest university library and ask to speak to the expert bibliographer on your topic. Ask this bibliographer what presses are best regarded on your topic. Request help in identifying other regional publication resources in your discipline, such as writers, editors, and indexers; organizations; contractors; publications training programs; and publications manuals and handbooks.
 - Go to the volumes *Publishers, Distributors, and Wholesalers of the U.S.* and *Books in Print* (see bibliography) at your local library, and look under your topic and in your region for names and addresses of appropriate publishers.
- ***To find possible partners*** to help you in the planning and development of your publication, consider approaching the following sources of help:

- Contact your SO curator and other SO disciplinary specialists, park archivist and librarian, ParkNet cluster and park coordinators, and Cultural Resources Web Team leader, National Center staff and the NPS Web master. They can provide ideas and guidance for your publication project.
- Look up the volume *The World of Learning* (see bibliography) in your local library. Identify the various academies, learned societies, research institutes, libraries and archives, and universities and colleges in your state and region. Consider and explore forming partnerships with these groups. Ask your local bibliographer to help you determine if they have a publishing record. If so, look at the reviews of their work, then contact these organizations.
- Contact your local or state university publications program (in the English department, generally) or multimedia communications department, which provide guidance, interns, and editorial expertise. The university's press might provide guidance, editorial expertise, and actually publish the work for you.
- Talk to your local or state university computer science department (for CD and Web publications), which can help with hypertext mark-up language (html) coding, Web access, layout, and technical issues.
- Contact your local newspaper, which might help you find suitable participants.
- Contact local professional organizations, which can help you find good contract writers and editors. Check published sources such as *Encyclopedia of Associations* and *Instant Information* at your local library.

All partners should be informed early in production, that official publications must be reviewed to ensure that any NPS policy position described in the publication is accurate.

12. *Why would I consider a partnership?*

Partnerships have distinct advantages and disadvantages. See the following chart.

Advantages and Disadvantages of Publishing Partnerships

Advantages	Disadvantages
<ul style="list-style-type: none"> The partner may have expertise in writing, editing, indexing, publishing, marketing, or topical areas the NPS staff lack. This expertise is essential to getting the publication done. 	<ul style="list-style-type: none"> The partner may wish to control how the project is planned, written, and produced, ignoring NPS goals.
<ul style="list-style-type: none"> The partner may have resources for publishing, such as equipment, funding, or facilities that NPS lacks. This expertise may be essential to getting the publication done. 	<ul style="list-style-type: none"> The project may be reshaped to fit the partner's schedule and budget, altering the NPS publication deadline, or the desired publication specifications.
<ul style="list-style-type: none"> The partner's resources may allow the NPS publication to have an increased press run (a larger publication edition) and a lower unit cost. 	<ul style="list-style-type: none"> The partner may imperil the partnership by requesting all copyrights to the work or exclusive licensing. The partner must be warned that work produced by NPS employees during work hours can't be copyrighted (although the rest of the publication can be) and that NPS doesn't provide exclusive license to anyone. These negotiations may slow production.
<ul style="list-style-type: none"> The partner's resources may allow the NPS publication to have higher quality specifications, such as more illustrations, full-color illustrations, an illustrated cover, cloth binding, larger type, a contract Web designer, and a more long-lived format. While NPS staff may NOT accept personal payment for publishing material produced during work hours, some NPS parks have had private publishers send author's payments to the park's cooperating association as a donation to use for museum publications. Parks can also negotiate for a number of copies for NPS use. 	<ul style="list-style-type: none"> The partner may request all royalties generated by the partnership. This is a point of negotiation.
<ul style="list-style-type: none"> The partner's resources may allow the publication to be better marketed and distributed, thus enhancing the visibility of the museum collections. 	<ul style="list-style-type: none"> The partner may request special mention or credit within the volume that is not extended equally to NPS. This is a point of negotiation. NPS should have a credit, such as co-authorship, or a listing in credit lines, for work done for publications. All photographs must be credited appropriately.

13. *What should I do to prepare a publication?*

- **Prepare a schedule** so you can plan and manage the work effectively at all stages of publication. Schedules simplify life by telling you who is responsible for what piece of a publication and when.
- **Use a style manual.** It explains how to keep a publication's elements, from captions to text, logically consistent and parallel throughout. NPS park staff should use the *Chicago Manual of Style*, which explains how to manage all aspects of paper publication, from writing to editing.

Occasionally you may need style manuals for special publication formats, such as, *Wired Style: Principles of English Usage in the Digital Age*, or style manuals for special topics, such as *Science and Technical Writing: A Manual of Style* (see bibliography). Many groups issue specialized style manuals, such as the Council of Biology Editors, for specialized issues. The Museum Management Program (MMP) has developed an in-house style manual for the Plain English format used in this and other volumes of the *Museum Handbook*. Plain English is particularly effective for administrative reports, multimedia publications, and pamphlets and similar informal publications. Contact the Program Assistant, Museum Management Program, National Center for Cultural Resources Stewardship and Partnerships Programs, for a copy.

- ***Begin to research using the steps noted below*** once you have a rough research proposal and a list of questions to answer as described above.
 - ***Conduct a thorough computer search*** on your topics on various search engines on the World Wide Web.

Use boolean qualifiers (and, or, but not) to produce a clear search (for example: **dogs** and **cats**, but not **pumas**). Explore the topic thoroughly by using synonyms. Print, read, and file the results. Make any necessary changes to your research proposal and questions list.

Check Internet-based bibliographic databases and look for publication citations on your topic, which you can request on interlibrary loan through the Department of Interior Library or your local library. You might try the Library of Congress Marvel System at <<http://www.loc.gov>>.

Be cautious when using the Web for research. Select your information only from credible sources that are frequently updated, and which post their criteria for inclusion. Such sites often provide lists of authors and their credentials. Sites of universities, federal agencies, and professional organizations are likely sources. Avoid using personal homepages, fans' pages, or enthusiasts' pages as source material, as they may contain misinformation.

- ***Go to a university library*** after your basic Web research. Set up an appointment with the bibliographer and give the bibliographer a copy of your outline and explain what you are researching. Ask for help in identifying the best and most appropriate secondary and tertiary sources on your topics.

For example, the following may be helpful sources for monographs, journal articles, and textbook indexing and abstracting services.

In the Arts:
Art Index

Bibliography History of Art

In the Humanities and Social Sciences:

America: History and Life
Anthropology Abstracts
Historical Abstracts
Public Affairs Information Bulletin
Humanities Index
Social Sciences Index
Social Sciences and Humanities Citation Index

In General Studies:

Dissertation Abstracts (now on CD-ROM)
Monthly Catalog of U.S. Government Publications
Readers Guide to Periodical Literature

In Natural Sciences:

Biological Abstracts
Science Citation Index
Wildlife Abstracts

Ask for similar resources for databases and unpublished sources, such as archival and manuscript collections.

- ***Answer the questions you developed using the sources you've located.*** Flesh out your outline with notes on the topics covered. As you research, take good notes so you don't inadvertently plagiarize or infringe on copyright. Capture complete citations for all sources used.
- ***Determine which published sources are considered most valuable.*** Consult the citation indices listed above, look at book reviews (ask your bibliographer to help locate them), or ask for the advice of the bibliographer or a discipline specialist. As with Web sites, more current publications by major university presses have an advantage over obscure or self-published works. Reviews and the bibliographer can help you evaluate sources.
- ***Answer your research questions.*** Keep an alphabetical list of topics to be researched. This list might look like Figure 3.3, Sample Research Sheet. Answer your questions and record the bibliographic citation of your sources. Check and locate missing information. Have peers review it. Ensure your research is complete, accurate, and devoid of stereotypes and preconceptions. Accurately cite your sources.
- ***Go to the museum collections*** after your basic research is completed. You or the author will need staff time and assistance to locate and pull objects and arrange for photography or photocopying.

- **Travel to see other museum collections, and consult sources at libraries, archives, and universities** to complete research. Funding for such work should be included when planning the project budget. Use the *National Union Catalog of Manuscript Collections* available via the Research Library Information Network (RLIN) at many university libraries, or via the Library of Congress Web site at: <<http://www.loc.gov>>, to locate appropriate archival source materials. Refer to *MH-II*, Appendix D, Museum Archives and Manuscript Collections, for an overview of how archival research is conducted.

14. *When do I begin writing text?*

- **Complete your note taking and research**, then develop a revised outline in question form (see the Table of Contents for an example) *before* you begin drafting text. If you write the text before you have completed your research, you may have significant rewriting to do later.
- **Decide what writing style you will follow**. Most curators and archivists are taught standard academic writing style in school. This style, as illustrated in the *Chicago Manual of Style*, is perfect for scholarly publications, such as exhibition or collection catalogs. Administrative, educational and popular publications benefit from the more lively and direct tone and style described below, and referred to throughout the *Museum Handbook* series as Plain English.
- **Think about your audience**. As you begin writing, review your research. Arrange your research outline in order of importance to your audience. Group the questions on the outline using the questions as headers. Start each section with a summary of the section’s contents.

15. *What does a writer do?*

As you write, follow the sequential activities described below:

Writers' Dos and Don'ts List	
To write well, do . . .	Don't . . .
<ul style="list-style-type: none"> • Develop an outline consisting of a structured list of questions to be answered. Work from this outline using plain English writing (active voice, concrete examples) rather than indirect bureaucratic language. Write your first draft, working directly from the outline. If you run into problems, rewrite the outline and start over. 	<ul style="list-style-type: none"> • Don't forget to give your outline a peer review to confirm the necessary issues are covered, and the order is rational. Don't fuss about details as you write the first draft. Get the basic text down, then fix it. Don't worry if you have to rewrite your outline once you start writing.
<ul style="list-style-type: none"> • Begin your writing by placing one of the following sections first: <ul style="list-style-type: none"> - most important section - most general section Or if one section will be more useful to your audience than all others, consider beginning with the most frequently used sections. 	<ul style="list-style-type: none"> • Don't automatically organize your writing by chronology or discipline, think of what your reader will want to know first. Instead, try to provide the most useful information first.

Writers' Dos and Don'ts List	
To write well, do . . .	Don't . . .
<ul style="list-style-type: none"> • Start each section with a summary that is short, lively, and direct. 	<ul style="list-style-type: none"> • Don't make your summary long, rambling, and chatty.
<ul style="list-style-type: none"> • Use ordinary English, for example: <ul style="list-style-type: none"> - meet not attain - begin not commence - boundaries not parameters - often not frequently - finish or complete not finalize 	<ul style="list-style-type: none"> • Don't use complex, discipline-specific, or technical terms unless essential. Define all technical language in the text. Don't use bureaucratic, indirect, affected, or gentrified language (such as parameter, input, approximately, consequently, currently, compile, consists, discontinue, or specificity).
<ul style="list-style-type: none"> • Use the active voice and action verbs. Speak directly to the reader wherever possible, for example, "Write using lively language." 	<ul style="list-style-type: none"> • Don't automatically use the academic, passive voice and avoid all forms of the intransitive verb of being. Don't use nouns or adjectives as verbs (such as to target, to optimize, to keyboard, to archive, to interface, or to finalize).
<ul style="list-style-type: none"> • Use bulleted lists for strings of parallel terms, such as: <ul style="list-style-type: none"> - deer - elk - moose - caribou 	<ul style="list-style-type: none"> • Don't drown your reader in a swamp of words. Don't add items that aren't parallel to your list. If your list includes deer, elk, and moose, keep it parallel.
<ul style="list-style-type: none"> • Spice up your text by using: <ul style="list-style-type: none"> - bold for emphasis - headers in mixed case - varied punctuation (,;--?!) - varied paragraph and sentence lengths - varied sentence structure 	<ul style="list-style-type: none"> • Don't produce cookie-cutter text. Don't automatically structure all your sentences as a noun followed by a verb followed by an adverb. Avoid excessive use of prepositional phrases (of the . . . , by the . . . , around the . . . , and so forth).
<ul style="list-style-type: none"> • Use lively headers throughout your text to signal changes in topics, and to keep the reader's attention. Follow your header with a summary, your major points, and supporting details, in that order. List examples in order of diminishing importance. 	<ul style="list-style-type: none"> • Don't write long blocks of undifferentiated text as it discourages readers.
<ul style="list-style-type: none"> • Write concretely, using specific examples, such as, "The twelve-year-old girl wove six cotton coverlets in 1876, five of which are in our museum collection." 	<ul style="list-style-type: none"> • Don't use overly broad or abstract examples, such as "the girl wove cloth."
<ul style="list-style-type: none"> • After the first draft, have a discipline-specialist editor to do a substantive edit. The editor will identify and fix the logical and structural problems, streamline the writing, identify where fact checking is necessary, and correct any errors and questionable assumptions. 	<ul style="list-style-type: none"> • Don't circulate your text for a wide peer review <i>until</i> you have completed this substantive edit or you will waste the panel's time.

Writers' Dos and Don'ts List	
To write well, do . . .	Don't . . .
<ul style="list-style-type: none"> • Following all necessary follow-up research and rewriting after the substantive edit, edit for style, grammar, punctuation, and format (footnotes, bibliography, and other special components). 	<ul style="list-style-type: none"> • Don't assume you can effectively edit your own writing. Find a subject specialist editor. After this second edit, obtain a peer review of the piece.
<ul style="list-style-type: none"> • Check to ensure you have completed all phases of the edit. Have an editor fix any stylistic errors according to your style manual. 	<ul style="list-style-type: none"> • Don't forget to instruct the editor as to what he or she is to watch for in the text. This includes spelling, punctuation, compounding, abbreviations, italics, headers and footers, active voice, unclear antecedents, bibliographies, variant numeration (1, one, or I), and acronyms.
<ul style="list-style-type: none"> • Have an outside peer review team read the piece for content. Fix any problems. Be sure to give your reviewers advance notice of what they are to review and how much time is needed. 	<ul style="list-style-type: none"> • Don't skip the peer review. It is an essential part of publication.

16. *What are the steps in selecting content?*

When you are selecting content, such as illustrations, sound recordings, or videotape, for a publication, you should be concerned about the following:

- **legal restrictions** (See *MH-III*, Chapter 2, Legal Issues.)
- **cultural sensitivities** (See *MH-III*, Chapter 1, Section D, Cultural Issues.)
- **audience's comprehension level, interests, and ability to use what you are selecting** (See Question 7, "How do I identify the audience?")
- **whether the collection is widely available and extensively used elsewhere.**
- **the appropriateness of the collection to the topic**

Talk to discipline specialists if you are uncertain whether the collection is pertinent to the topic, and consider the following criteria:

- **informational value:** Is it a clear and useful example? The content under consideration should document:
 - who* (people, groups, corporations, and animals)
 - what* (objects, plants, structures, activities, and events illustrated)
 - where* (places)
 - why* (circumstances of creation or documentation)
 - when* (date, era, or period)
 - how* (underlying reasons or causes, materials, techniques, and processes being covered)
- **artifactual value:** Is it a fine example of a particular process or format?
- **associational value:** Does it relate to a major figure, culture, event, or place, such as the Booth derringer used to kill Lincoln?
- **evidential value:** Is it historical, legal, or scientific proof of an activity or event, such as land records, or a type specimen that was labeled completely and photographed at the time of capture?
- **administrative value:** Does it provide a baseline of park resources, such as resource management records, maps of back country land, GIS data on park resources or a herbarium that includes all plant species found in the park in 1900?
- **monetary value in the marketplace:** Are the selected collections viewed by the public as treasures, such as the silver collection at Morristown National Historical Park, Peale paintings at Independence National Historical Park, or Ansel Adams photographs at Yosemite National Park?

17. *How do I obtain licenses and permissions?*

If you are researching or preparing your own publication, you are responsible for obtaining permissions (licenses) to use any materials you quote, reproduce, or otherwise use in the text you publish. All other researchers using the park collections must obtain all rights and permissions themselves. You do not have to obtain the rights or permissions for a researcher.

To obtain permissions, write to the creator of the work (author, photographer, editor, or publisher) and obtain written permission to use the materials. You may be asked to pay a fee.

In your letter of request, you should clearly identify:

- the title of the work
- the location where you found the work (full bibliographic citation, if possible)
- the nature of the publication in which you wish to use the work, for example, as an interior full-page illustration in a commercial, for profit book's first edition
- the type of usage you want approved, such as nonexclusive international publication rights in all languages, and for all editions, for all media, including the Internet

To protect your park from a potential lawsuit, you must be able to show you made a good-faith effort to obtain a license or permission. This effort should include:

- identifying the work's creator
- attempting to locate and contact the creator for a permission
- searching the U.S. Copyright Office records for any copyright on the materials (Write to the U.S. Copyright Office at the Library of Congress, or use the Library of Congress Copyright Office Web Page at <http://lcweb.loc.gov/copyright/>. Once on the page, select the Copyright Office Records-How to Conduct a Search.)

Publishers' addresses can be obtained from *Books In Print*, available in most public libraries. You also must obtain permissions required under state and federal privacy and publicity laws. See *MH-III*, Chapter 2, Legal Issues, for details. See Figure 3.2 for a sample Intellectual Property Permission Request.

Obtaining permission may take weeks. Allow ample time in your publication schedule to do this. With any luck, your creator or publisher will sign your letter of request and return it. Without permission, don't publish the item.

18. *What do I need to know about writing captions?*

Captions are the context you provide for an image. A good caption enhances the value of the image. A poor one leaves readers wondering why the image was selected and reproduced and leaves the image subject to misinterpretation. Captions tend to be terse, often incomplete, sentences.

A good caption includes the following elements:

- item title in quotes, followed by (or)
- object name or collection title
- brief description (including material and measurements)

- dates(s)
- plate, page, or image number in the text
- name of the object creator
- photographer, if appropriate
- park name
- catalog number
- negative number, if appropriate

For example:

Western Mono Cooking Basket
 ca. 1910-1920
 Collected by Ansel F. Hall at the 1921 Indian Field Days
 Sedge root, bracken fern root, bunchgrass. H 6 1/2", Dia. 14"
 Yosemite National Park, YOSE133
 Gift of Mrs. William Moyle DuVal

Plate 97, Keystone View Company, "Yellowstone National Park" shows
 an appreciative crowd of Hardy Hotel waitresses in full costume
 gathered around Old Faithful ca. 1918. Wapantucket Collection, YELL
 123, Negative # 98977

19. *When do I begin review
 and final fact-checking?*

You should fact-check throughout your project. The easiest way to do this is to produce a research sheet. A research sheet is an alphabetical list of facts that need to be checked, such as spellings, dates, how events happened, and so forth. Your research sheet will grow to enormous proportions if you do your job right. A research sheet list of entries might look like Figure 3.3, Sample Research Sheet.

Before you give your piece to the editor, go to the library and check all the missing information on the research sheet. After reading the text, the editor will ask additional questions that will become part of your research sheet for later fact-checking. Your research sheet should be completed, all research sheet answers found, and all research incorporated into the text before it goes out for peer review.

20. *What do I need to know
 about editing?*

You can't overstate the importance of a good editor to any publication project. A professional editor can significantly improve your manuscript. Self-editing rarely catches most problems. You know what you were trying to say and are not in an objective position to judge if you did so effectively. Work with a discipline-specialist editor to create the finest possible product. Tell the editor who your audience is and the publication's purpose, specifications, and deadline.

Editing occurs in several stages:

- **Substantive Edit** is the first edit a piece receives by a subject specialist editor (not the writers). The substantive editor focuses on the logic, structure, completeness, flow, and organization of the piece and may reformat and correct word usage. A substantive editor points out or fixes:
 - structural flaws in the work's organization
 - errors in logic and poor reasoning
 - weaknesses in theoretical presentations or research methodology
 - inaccuracies and errors
 - incompleteness, missing sections, and gaps in the theme
 - poor flow of sections and ideas
 - awkward writing
 - unnecessary repetition
 - poor word usage or ineffective writing

See the Museum Management Program Editing Checklist, Figure 3.9 for a full list of substantive editing tasks. A good substantive editor also may point out everything a copyeditor identifies (see below). Substantive editing is slow and time-consuming. A substantive editor may get through no more than 5-10 pages in a day if the manuscript is poor.

- **Copyedit** is the second major edit a piece receives by someone other than the writers. In general, the errors described under the substantive edit (above) should already have been corrected. The copy or stylistic editor focuses on and fixes:
 - excessive wordiness
 - improper tone or voice
 - spelling and grammar errors
 - punctuation errors
 - incorrect word compounding
 - excessive use of abbreviations, acronyms, and jargon
 - improper use of italics, bold, and underlining
 - nonparallel or incorrect headers and footers
 - excessive use of passive voice

- unclear antecedents
- inconsistent bibliographic and numeric style
- noun and verb disagreements

Copyediting is the fastest way to improve a manuscript. A copyeditor focusing on simple errors in grammar, punctuation, and spelling can edit at 5-15 minutes a page, depending upon the state of the manuscript and the level of improvement desired. Simple grammar, punctuation, and spelling are the easiest to correct. If the editor is to improve sentences and correct word usage, the work will take longer. See the Museum Management Program Editing Checklist, Figure 3.9, for a list of copyediting tasks.

21. *What do I need to know about design and layout?*

Layout must enhance, not obstruct the usefulness of your publication. Design reinforces the text, providing a clear visual guide to its structure. Good layout attracts attention without overwhelming the message. An effective layout makes the message easier to read. Any element that obstructs the text or makes the reader's eye jump around the page is a hazard and should be changed.

Four basic principles to consider when planning the layout of a book, article, pamphlet, CD-ROM, or Web page are:

- **Contrast:** Just as in writing, varying sentence structure and length and paragraph length is important. Strive for varied type levels, colors, sizes, lines, thicknesses, shapes, spaces, and other elements to make pages more interesting. Contrast the differences between unequal items. Contrast effectively organizes text, indicating when text is different or new. When using contrast, avoid using elements that are just slightly different or your contrast will vanish. To be effective, contrast must be carefully controlled and balanced.

The most common design mistake made by amateur designers is overdoing contrast with too many different type sizes, styles, column widths, shapes, and spaces.

- **Consistency:** Develop a consistent design strategy for your piece using repeating elements as road signs for the reader to find the same parts of the text on each page. Give your piece a unified identity by using repeating colors, textures, spatial relationships, shapes, bullets, numbered lists, typefaces, headers and footers, rules (lines), and bolded text. Repeating design elements clarify the relationships among the parts of the text for the reader, allowing readers to focus on what is being said.
- **Relationships:** Place related items in a cohesive grouping. Don't group unlike materials or place materials equally distant all over the page. Grouping by relationship streamlines your design and eliminates clutter, giving your work a cleaner appearance.

- **Composition:** Place items on a page in a visual relationship so they appear balanced. Use your white space effectively. Feel free to be asymmetrical. Think of a page as a composition. Rather than continually centering text, try right or left alignments for a more sophisticated look. Don't place too many elements on a page. Don't stick design elements in corners.

Take a look at the NPS ParkNet and "Links to the Past" to see effectively designed Web publications.

22. *How do I work with a professional designer?*

If a professional designer is working on your publication, you can assist the designer by providing certain information when the book is planned, such as:

- the anticipated audience
- the message
- the schedule
- publication specifications, such as format; size; quantity of illustrations, charts, graphs, tables, or other special media; quantity, type, and placement of publication elements, such as front matter (prefaces, tables of contents, and acknowledgments), back matter (such as indices, bibliography and footnotes), or a credit page on a Web site
- format and media (a particular paper, CD-ROM, or Web format)

The designer will:

- produce the cover, packaging, or visual component
- develop an overall concept for the publication
- select all typefaces
- place all illustrations
- determine color usage
- set all text into units
- determine how the publication's elements will work together

If you or your team must design the publication, you will need training, a partner, or a contractor. Consider asking your local newspaper staff for help, or take classes at your local university.

23. *Should I produce a camera-ready copy or an electronic manuscript?*

If you have a choice, produce an electronic manuscript (using a word processing software that can be saved to a hypertext mark-up language ("html") format) to be designed and laid out by a trained designer. Your publication will be enhanced greatly by the work of a professional designer.

If you must do the design yourself, try to find partners in publications departments, local newspapers, or call the Volunteer in the Parks Program to locate volunteers with design skills.

24. *How do I obtain illustrations for my publication?*

Once you've determined what kind and number of images you want, select the appropriate format you want to use. Some of the options are color prints, black-and-white prints, slides, or transparencies in various sizes from 35mm to 8" x 10".

Obtain illustrations during research while you are working in museum or archival collections. Use the Sample Intellectual Property Permissions Form, Figure 3.2, to obtain permissions. If you must acquire images from outside sources, follow their procedures and obtain permission to publish them from the appropriate source. This may be costly and time consuming.

Determine the number and quality of record or publication photographs of the objects you wish to publish. If high-quality reproductions of these objects are desired, you may need to have them made. Complete the park's Researcher Duplication Form (see *MH-II*, Appendix D, Museum Archives and Manuscript Collections, Figure D.16) indicating the type, quality, format, and size of image desired. Work with a photographer, and as part of the contract, arrange a visit, handle the object, supervise any on-site work, and instruct how off-site handling and duplication should be done. You may have to pay a cost-recovery fee for the photographs.

To save time, capture the appropriate caption and credit line information when you request the photograph. See *MH-II*, Appendix R, Curatorial Care of Photographic Collections, and *MH-III*, Chapter 2, Legal Issues, for guidance on copyright, privacy, and other related intellectual property issues.

Q. Producing Paper Media

1. *What do I need to know to select the best kind of paper publication for my purpose?*

You should be aware of the advantages and disadvantages of the various types of paper publications. See the chart below:

Advantages and Disadvantages of Paper Publications		
Format	Advantages	Disadvantages

Advantages and Disadvantages of Paper Publications		
Format	Advantages	Disadvantages
Brochures (includes pamphlets and fliers)	<ul style="list-style-type: none"> • Inexpensive to produce and distribute • Easy to file • Potentially attractive to all ages • Can incorporate images and text • Can be placed in windows and on walls 	<ul style="list-style-type: none"> • Easy to lose • Often thrown out, not cataloged and maintained • Can be useless if not well-written and designed • Allow relatively little space for text and images • Usually intended for relatively short number of years
Journals	<ul style="list-style-type: none"> • Many are eager for content, so you may get published easily • Easy to submit materials • Are maintained by libraries for use later • Can reach many thousands of people • Can incorporate images and text • Are well indexed by a variety of reference works 	<ul style="list-style-type: none"> • Quality can be very uneven • Usually printed on poor paper, meaning a relatively short lifetime, thus fewer people have the opportunity to read it • Quality of image reproduction can be poor
Monograph (Book)	<ul style="list-style-type: none"> • If the press has a good name, can enhance the reputation of the publication • Allows a greater scope for investigation than articles or pamphlets • If the paper is high quality, will be maintained in libraries for many years (>100) • Can incorporate images and text 	<ul style="list-style-type: none"> • Frequently published in very small editions, making the cost-per-volume high • Color images often kept to a minimum, in a single section, or require a financial subsidy because they increase cost • Easy to produce a mediocre volume
Catalogs	<ul style="list-style-type: none"> • Can effectively showcase collections, exhibitions, the work of an artist, and staff scholarship • Can be organized by topic, geography, creator, period, style, format, medium, or many other subjects, allowing the authors maximum flexibility • Often accompany an exhibition, thus providing additional benefits since viewers can actually see the originals and then learn about their context 	<ul style="list-style-type: none"> • With full-color, high-quality images have become extremely expensive in the last two decades • Require extensive reproductions, permissions, and high usage fees for images

2. *How do I plan and develop a brochure?*

Follow the same steps that you follow when producing a book. See Section E, Producing a Publication Using Museum Collections, above. Follow the steps outlined in Figure 3.1, Master Checklist for Publication Project (Sample).

- ***Resources you will need***

Pamphlets and brochures can be done inexpensively on xerographic copy machines, requiring only researchers, writers, editors, designers, technical layout staff, and photocopying supplies.

Brochures can be done professionally by a contract writer and a professional design firm, who prints them in color on coated paper stock. For professional publications, you must budget for contractors, supplies, permissions (usually very few), printing, last minute textual changes, and shipping costs. The costs can vary depending upon the quality and quantity desired.

- ***The two types of brochures***

The Harpers Ferry Center (HFC) of the NPS uses two standard types of brochures:

- ***Site Bulletins***: These are park-produced, supplementary publications for urgent or intermittent needs. The bulletins include standard formats, Unigrid-based layouts, computer (or occasionally typewriter) composition, and are reproduced by office xerographic copier (or occasionally a printer).

Content can be topical and include changeable information such as temporary park folders, trail guides, schedules, and other information essential to park operations. For specifications for this pamphlet type, contact HFC's Publications Officer and request the Site Bulletins Supplementary Graphics System pamphlet.

- ***NPS Site Folders***: These pamphlets are in the Unigrid standardized graphic and production design format developed for NPS. Production follows a broadside approach on folded size, one printing paper in two sizes, and 10 basic formats. The system's pivotal component is a grid of horizontal and vertical lines creating small rectangles over the 10 basic formats. This grid provides a structure for the layouts. For more information on Unigrid, contact HFC's Publications Officer and request the Unigrid design specifications pamphlet.

- ***Selecting an appropriate type of brochure***

Use the supplementary graphics systems format for site bulletins, including supplementary documentation on museum collections, exhibitions, and similar matters. Use the Unigrid system of design for all pamphlets.

- ***The steps for producing a brochure***

The steps mirror those in Figure 3.11, Digital Publication Project Checklist. Pamphlets are less elaborate than books and require fewer participants, less production time, and less funding. They also have fewer design options, since the Unigrid system dictates the layout. Brochures can be produced effectively in-house.

3. *How do I plan and develop a journal article or an entire journal issue?*

Contact the journal editor and find out the submission guidelines, schedule, organizing issue themes, and the need for unsolicited pieces for the coming year or two. Consider journals with a history of pieces on material culture, history, art history, or discipline areas that mirror NPS museum collections such as anthropology, archeology, archives, natural resources, and similar topics.

- ***Determine the format for your submission***

Most periodicals have submission guidelines, which you can obtain from the editor. These guidelines explain in detail how to submit articles and special issues. They also explain submission format, including bibliography, required writing style, and publication scheduling.

Some journals post a scheduled list of special theme issues for which they are soliciting articles. Frequently these listings can be found in the journal or on the publication's Web site. If you are interested in submitting materials on any of these themes, notify the journal of the topic of the article you would like to submit.

- ***Provide the editor with the following***

By publication deadline, you should submit the completed peer-reviewed article with any supplementary material, such as bibliographies, footnotes, biographies, or acknowledgments, in the format and style described in the submission guidelines. Many journals conduct their own peer review of a submitted article. Generally, the editor will tell you the desired publication format and what you need to submit.

- ***Other work you must do***

Once the journal editor reads your piece, you are usually asked to review the page proofs (sometimes called galleys). These pages may be printouts or printed text and headings set for the full width of the page. During proofing, you should look for lost text, missing headers and footers, word breaks, and all the other items marked on Figure 3.10, Proofreader's Checklist for Reviewing Page Proofs, Mechanicals, and Bluelines.

Errors found on proofs must be marked as described in the *Chicago Manual of Style (most recent edition)*, or in Figure 3.10. During this final stage of publication, you should have completed all of the earlier tasks described above.

- ***What you will receive from the editor***

You should receive a number of author's copies of the publication for use by the park as stipulated in the contract, at least one copy of which belongs in the park archives and one in the park library

You can't accept money for a work created during your normal scope of work as a NPS employee. Speak to your park Ethics Officer to see if any money can be accepted by the park cooperating association for the park's use.

You must never personally accept a check or other payment for work completed on NPS time.

- ***The steps in producing a journal article***

The steps are similar to those for all other publications. See Figure 3.1, Master Checklist for Publication Project, and Figure 3.8, Paper Printing Job Organizer.

- ***Additional steps you must take if you are producing an entire journal issue***

If you are producing an entire issue, you are acting as the editor. When serving as an editor, you must also:

- locate authors
- coordinate with all participants to avoid duplication
- manage the publication schedule
- edit all text, both substantively and for style
- fact-check if authors won't
- make textual changes after consulting with authors
- submit articles for peer review
- revise as necessary, edit, and fact check
- locate sufficient illustrations if authors don't
- obtain permissions if authors don't
- ensure all text and bibliography are in appropriate style for the journal as expressed in the journal's submission guidelines
- coordinate with the standard journal editor

- manage the shipment of bluelines, page proofs, and mechanicals to all authors for changes and review
- ensure all changes are checked in bluelines, page proofs, and mechanicals, and implemented if appropriate
- ensure all authors receive free copies of their work
- thank all authors in writing

4. *How do I plan and develop a monograph?*

Monographs are scholarly works on a specialized topic, frequently published by university presses. Skills necessary to produce a monograph are listed in Figure 3.1, Master Checklist for Publication Project, and Figure 3.8, Paper Printing Job Organizer.

- ***Necessary resources***

To create a monograph, you need sufficient resources to complete the tasks listed in Question 3 above. The cost to the park depends on how much of this work your staff can complete. If your staff doesn't already have these skills, you will need to contract:

- researchers
- writers
- editors
- design and layout staff
- indexers
- printers
- binders
- marketing staff

You will have to budget for:

- permission fees for pictures and quotes
- printer's surcharges for last minute changes in text during the blueline, page proof, and mechanical stages of printing
- supplies (paper, glue, and ink)
- shipping charges
- advertising
- review and formal copies to reviewers

- author copies

The costs for a book publication depend upon the size of the edition, the size of the volume, the number of illustrations, the number of changes made to the text during the final production stages (proofs, mechanicals, bluelines), the contracting policies of the publisher, and the contents, and nature of the book.

- ***Types of monographs***

A monograph can be a scholarly book, article, or pamphlet. Commonly, monograph refers to a scholarly bound volume, such as a book.

- ***Their advantages and disadvantages***

See the Publication Formats Summary Chart in Section E, above, Producing a Publication Using Museum Collections.

- ***Self-publication***

Self-publication is a good choice if your park has the skills necessary to research, write, edit, design, index, print, and publicize the book. If not, you would be wiser to consider working with a professional press, at least until you and your publications team have experience to do the work at a professional level.

While a high-quality publication will enhance the park's reputation, a poor publication can damage it, particularly in the scholarly community. It would be better not to publish anything than to publish a slipshod work.

- ***Working with a publisher***

Non-federally funded projects may be printed by any publisher. Federally funded projects, however, must be printed through GPO. It is perfectly appropriate to work with a publisher for a non-federally funded publication *unless* one or more of the following applies.

- Use clearly violates state or federal law or NPS or DOI policies and procedures, such as publishing archeological site, cave, or well locations.
- Use violates NPS ethics policy, such as publishing sensitive data. (See *MH-III*, Chapter 2, Section F.)
- Publisher demands an exclusive license or a long-term contract or agreement.
- Publisher's contract doesn't meet NPS standards as expressed by the NPS solicitor.

- Publisher asks for a type of use that places the museum object at risk physically, such as stress on fragile materials.
- Publisher asks for a use that poses a risk to intellectual property rights, such as producing electronic copies of copyrighted images or images with privacy or publicity related issues for posting on the Web where the images will not be secure from unauthorized downloading, transferring, copying, and manipulation of content.
- Publisher requests the right to use the National Park Service name, the park name, and the arrowhead without obtaining appropriate permissions from the NPS solicitor and the Policy Office.
- Use clearly violates existing agreements with traditionally associated groups.
- Use implies NPS, DOI, or government endorsement of the publisher or the publisher's products.

For further guidance see the sample agreements and contracts in Figure 3.5, Sample Cooperative Publishing Agreement, and Figure 3.12, Memorandum of Agreement for the Joint Production of a CD-ROM.

- ***Finding a good publisher***

Research who is publishing your topic. Talk to discipline specialists. Search the World Wide Web under your topic and the word "publisher."

Go to your local university library and ask the bibliographer on your topic area to recommend publishers who work in your discipline or look in one of the following reference sources:

- *Publishers, Distributors & Wholesalers of the United States* [current year] (this volume is organized geographically)
- *Books in Print* (contains an alphabetical list of publishers)
- *CD-ROMs in Print* (contains an alphabetical list of publishers)

- ***Developing a sample section or chapter***

If well prepared, a sample section or chapter is a powerful tool that can be used in:

- fund raising
- convincing institutional partners or other authors to work collaboratively

- locating an editor
- finding a publisher

A sample chapter frequently is used as a marketing tool to convince publishers to accept a publication.

- ***Negotiating with publishers***

Before you meet with the publisher you must be prepared.

- ***Know your park's or center's publication specifications***, including paper and binding requirements (refer to Question 3 of this section). For example, the park wants 5,000 8" x 11" hardback volumes with a full-color cover, printed with all indexing, editing, layout, paper selection, and binding done by the publisher.
- ***Learn what you are forbidden to offer***, such as exclusive licenses, granting authorization to publish intellectual property rights you don't have, or access to legally restricted materials.
- ***Find out how the project will be funded*** such as what resources the park can provide and what must be provided by the publisher or by a grant funder.
- ***Know your human resources and skills the park can supply*** for this work, for example, can the park do some of the picture research, indexing, or editing?
- ***Know what partnership resources the park can obtain***, such as help from local universities, cooperating associations, foundation funding, the National Park Foundation or National Center for Preservation Technology and Training publication grants.

Examine all publishing contracts carefully. Avoid long-term contracts that lock you in for more than 5 years. Ensure if the book goes out of print, you have a clause allowing the park to reprint it. Review contracts with the contracting office, the NPS Solicitor, and SO staff. Publishers routinely change their standard contracts if the collaborating authors insist. Negotiate! You don't have to settle for the publisher's first offer.

Once you meet with the publisher, do not sign anything for the NPS until the park superintendent, contracting officer, and the NPS solicitor agree the offer should be pursued.

Never grant "all rights in perpetuity" to anyone.

- ***Creating a publisher's agreement***

The following questions should be answered in a publisher's agreement.

- ***When do payments start to facilitate production cost recovery?***
Stipulate on which editions the park receives cost-recovery payments. Confirm how much, if any, payment the park will receive. Confirm if the park will receive an advance, and the amount of the advance. Stipulate what cost-recovery payments the park will receive for revised or later editions. (*Note*: most commonly this funding is paid to the park's cooperating association or the National Park Foundation.)
- ***What expenses will the publisher pay?*** For example, will the publisher pay for:
 - an index?
 - a special paper for illustrations?
 - permission fees for illustrations?
 - copyediting?
- ***What manuscript components must the park provide?***
 - front matter (tables of contents, introductions, acknowledgments, prefaces)?
 - text?
 - illustrations and captions?
 - permission to use quotes and images?
 - back matter (indices, bibliographies, footnotes)?
- ***What are the quality standards the manuscript must meet for acceptance?***
 - Chicago Manual of Style* format and style?
- ***What rights will the publisher have?***
 - North American printing rights?
 - International rights?
- ***What happens to the rights if the book goes out of print?***
 - Can the park reprint it?
 - Can the park put some or all of it up on the Internet?

– ***Who has the copyrights?***

the publisher?

– ***What rights does the park have to read and correct proofs?***

What will the park have to pay for author's alterations to page proofs? (**Note:** authors usually are allowed to make proof modifications of between 5-10% of the initial cost of composition. Changes over this amount usually must be paid for by the park.)

– ***What number of free author's copies will the park receive?***

5-20 copies?

• ***Defining your responsibilities***

Once your negotiations are completed, your publication contract, based upon the publisher's agreement described above, should stipulate precisely what it is you are to produce. Your next step is to identify an appropriate editor, author(s), and decide upon a schedule.

Generally, the park is responsible for the following activities beyond the usual research and writing:

- obtaining permissions for quotes and images
- guaranteeing that the work is original (no plagiarism), non-libelous, and doesn't infringe intellectual property rights of others such as copyright, publicity rights, or privacy rights. See *MH-III*, Chapter 2, Legal Issues, for guidance.
- indemnifying the press against claims or judgments on copyright, privacy, and other intellectual property rights issues

• ***Scheduling book production work***

See the schedule listed under monographs for an example of a book schedule. The time necessary for various stages of production must be determined with the publisher. The publisher probably will attempt to bring the completed work out for a specific merchandising catalog or publication season.

5. ***What do I receive from the editor and how do I respond?***

Check galley or page proofs. You may be asked to review the page proofs (sometimes called galleys) for lost text, missing headers and footers, word breaks, and all other items marked on Figure 3.10, Proofreader's Checklist. Errors must be marked as described in the *Chicago Manual of Style* (14th edition) or in Figure 3.10.

Review mechanicals. Mechanicals are page mock-ups produced by the designer. Mechanicals may be produced electronically and should incorporate type and images. Check these mock-ups as described in Figure 3.10, Museum Management Program Proofreader's Checklist. Watch for photographic completeness and print and line clarity. You should not be editing or changing words at this stage because you will be charged a fee for new typesetting, called author's alterations. You should check only for errors made by the printer.

Check negatives or bluelines. Finally, you must review the negatives made from the mechanicals, called bluelines. A blueline review is your last chance to check the print job. Use it to check for missing elements; smudged, blurred, or broken text; and flipped illustrations.

Mark all errors. Errors found on proofs, mechanicals, or bluelines must be marked as described in the *Chicago Manual of Style (14th edition)*, p. 105, Section 1.1, or in Figure 3.10, Proofreader's Checklist. Proofreading takes two-thirds to three-quarters the time it takes to do data entry. Some professionals cite the average proofreader rate as 4,000 words an hour with an error rate of one error missed on each proof page. Proofreading at each level (page proofs, mechanicals, and bluelines) should be done at least twice (preferably by two different people) to catch these errors.

More complex pages with charts, graphs, tables, foreign language text, technical text, and complex formatting will take longer and have more errors. When doing this work, take a five-minute break every hour or you will lose your focus and concentration. Allow time to check all text several times. Have someone unacquainted with the text review the final copy.

Pay particular attention to where pages, paragraphs, and sections begin; where pages and lines break; where type faces and sizes change; and where other errors frequently occur. Check all mathematical totals with a calculator. Pay attention to every element of the text, even boilerplate. Before this final stage of publication work, you should have completed all of the earlier tasks described above.

6. *What other work must I provide?*

The publisher may ask you to supply a brief biography and complete a marketing questionnaire. Inform potential publishers that primary markets for publications are park visitor centers and concessionaire shops, catalogs, and Web pages. Other choices might be the publisher's or NPS's Web page shop. Catalog sales and bookstores are other possibilities. You may be asked to provide the names of journals, newspapers, and magazines that might review your publication or to provide the names of potential reviewers.

7. *How do I plan and develop a catalog?*

Plan a catalog exactly as you would any other book publication. (See the section on book publication above.) Catalogs require scholarly expertise, excellent illustrations, and detailed descriptions of the style, period, materials, schools, formats, genres, themes, iconography, and subject matter of art works or the taxa of natural history specimens, and material culture of contemporary groups and prehistoric cultures for ethnographic and archeological collections. The value of what you do hinges on the quality of your illustrations and authors.

- ***Resources you'll need***

Generally museum exhibition catalogs incur the same expenses as books, such as shipping, advertising, review copies, printer's surcharges for changes to page proofs, and contractors' fees. However, because catalogs tend to be luxury volumes with more illustrations, the costs of some routine items greatly increase, such as:

- permissions fees for quotes and reproductions
- high-quality printing costs, particularly numerous and/or color illustrations
- high-quality paper costs
- contractors' bills for design, editing, and other services

Because of these expenses, oversize blockbuster catalogs usually cost significantly more than most publications to produce. Generally, exhibition catalogs can have poor resale value after the exhibition closes, so they are relatively expensive to underwrite. Many museums seek support from corporations or foundations to underwrite production costs.

- ***Types of catalogs***

A catalog may be a monograph, according to the dictionary definition. However, when most people use the word catalog, they are referring to one of the common types of catalogs described below.

- ***Catalog raisonne*** is a complete listing of all works attributed to an artist or school of artists by a scholar(s). This tends to be a fine or decorative arts format with in-depth examination of the artist.
- ***Collection catalog*** is an overview of the holdings of a museum, or a vehicle for studies in material culture or natural history.
- ***Exhibition catalog*** documents the exhibition themes and the items included in the exhibition.
- ***Union catalog*** is an archival term that refers to catalogs that cover the collections of a broad spectrum of repositories, such as all archives or museums in Texas or the entire Region or Support Office area.

- ***Develop collection catalogs by type of material, media, or format.***

Collection catalogs of all types are developed the same. If your catalog focuses on types of material, culture area, period, media, subject, or format, select an editor and authors knowledgeable on these issues.

- ***Choosing self publication***

Self publication is a good choice *if* you have:

- mastered all phases of publishing, including research, writing, editing, indexing, layout, design, print production, marketing, and distribution
- the ability to view your own work critically and revise it with a professional eye
- extensive publishing experience
- sufficient time to invest in this labor-intensive process

- ***Working with a publisher***

Work with a publisher when you need professional help to produce the highest-quality publication, or when you need someone else to absorb some of the production costs. Before beginning work, have a signed agreement in hand stating your responsibilities and the production schedule.

8. *Should I use permanent paper?*

Yes, because permanent, high alphacellulose, low lignin, neutral pH paper has a very long life, isn't expensive, and is environmentally friendly. By using permanent paper, you'll ensure that images and information about the park's museum collection will be available for research, education, and interpretation for several hundreds of years! Permanent paper should meet the international permanent paper standard (ISO 9706: 1994; Information and Documentation; Paper for Documents: Requirements for Permanence). In the printing contract specify "ISO 9706: 1994."

R. Producing Moving Images

1. *What types of moving images media are there?*

Several moving image formats can be used alone or in combinations. These are noted below. The field is evolving constantly with new formats and technological advances. Because of the complexity of formats and recording (gathering) and playback (delivery) equipment, you should always consult with Harpers Ferry Center-Audio Visual (HFC-AV) staff and specialists early in your project. The Interior Service Center, Telecommunications Services Office, may also provide this information.

- **Film:** Both a long-lived image recording system and a playback system. Films are made on stock using a camera and other specialized equipment. All film stocks have a light-sensitive layer called an emulsion and backing support called the base. Film stock has sprocket holes, which allow the camera, projector, editing machine, or printer to transport the film. Film has many formats, ranging from super 8mm, 16mm, super 16mm, and 35mm to 70mm, such as Cinemascope, Widescreen, and Imax. While many feature films are 35mm, 16mm is the most commonly used format.

As an image-recording medium, professional film captures high-resolution images. When you shoot film, you typically archive your camera original and have a work print made. You edit the work print and conform the camera original to the work print. This may be used as the master from which you'll produce copies. If you're making more than 10 copies, you should have an inner negative made of the original. A good lab can produce many copies from a master. This film can be used as is, or transferred to professional format videotape or laserdisc to produce top-quality interpretive shows. You'll need a projection system to show film.

- **Video:** Both a relatively short-lived image recording system and a playback system. For a new media, it is widely used in industry, home, and film-making. Video has many formats, ranging from Sony High 8, VHS-S, Super VHS, Super VHS-C, to Betacam and D2, which are professional formats. The latter delivers high-resolution images with a superior soundtrack. Video is gaining in acceptance because it is easy to use, portable, and transfers easily into digital technologies. Digital video produces a superior image over traditional analog formats.

You can use video as an image-recording system if you're doing a program on a small budget. Use professional videotape. Video is an inexpensive and easy way to distribute information on the park museum program, either by mail or a television screening. Videotapes wear out with repeated showings, so keep a backup supply. Videotape is both less durable and less expensive than film.

Video Cassette Recorders (VCR) are not as effective as laserdiscs for repeated use. Tapes wear out quickly and require regular maintenance and a backup supply. Videotapes can be transferred to laserdisc format for delivery.

- **Laserdisc:** Highly recommended as a delivery system because of its low maintenance, reliability, and durability. Because the laserdisc player only plays laserdiscs, film or video must be transferred to that format. However, once the video has been mastered to, and programmed for the laserdisc, it is much more dependable than running a videotape on a VCR. The laserdisc player gives you the option of using a computer controller, and can be controlled from a remote location. You can program alternate modes such as endless repeating, visitor activation, and send signals to dim lights or other timed events. One controller can control two disk players.

With either delivery system (videotape or laserdisc) you can use a monitor of any size for viewing purposes or a projection system.

- ***New video formats:*** Video formats are undergoing major changes. New technologies promise to improve greatly the quality of video signals for delivery systems. They are expensive and require special equipment. Professionals probably will move from laserdisc to these new media in the next few years. These new formats include ***High Definition Television (HDTV) and Digital Versatile Disc (DVD)*** which require different image recording and projection equipment. DVD has very clean images with few dropouts (a tear in the line), and good sound quality. It can hold video, audio, and computer data. Many DVD machines can play older CD-ROM formats. DVD aims to encompass home entertainment, computers, and business information with a single-digital format.

2. *How do I plan to make a film or video?*

The steps you take to plan to make a film or video are similar to those you take producing sound recordings, Web exhibits, and other publications described in this chapter. You should:

- identify the purpose
- identify your audience
- outline the message and the major points
- identify subject matter specialists
- develop a realistic budget
- select the media type and equipment
- select actors
- select locations
- get permissions
- edit, select music, prepare titles and credits

3. *What resources will I need?*

To produce good moving images, you'll need:

- subject matter specialists, writers, editors and actors
- video or film equipment
- director, producer, and editor
- camera, lighting, sound, and special effects specialist(s)

4. *What are the advantages and disadvantages of these formats?*

See the following chart.

Major Advantages and Disadvantages of Moving Image Formats		
Format	Advantages	Disadvantages
Film	<ul style="list-style-type: none"> • Better resolution than video. Produces higher quality images than video. • More durable and is an archival storage medium • Much longer-lived • Often used to shoot for editing on video • Has a warmer, more blended look 	<ul style="list-style-type: none"> • Difficult to produce. Requires specialized personnel and equipment. • Can take longer to produce • Expensive to copy • Costs slightly more to produce • May require projectionist to run the projection system for 35mm film
Laserdisc	<ul style="list-style-type: none"> • Excellent delivery system • Durable but is not an archival medium • Low maintenance • Reliable • Can be made from any videotape or still 	<ul style="list-style-type: none"> • Not a recording medium, it's only a delivery and distribution medium • Expensive • Proprietary—not easy to move to next generation of formats • Larger than CDs • Difficult to produce
Video-formats	<ul style="list-style-type: none"> • Widely used • Portability • More cost effective to produce and show • Can be made from any video or film • Easy to edit and produce 	<ul style="list-style-type: none"> • Analog format makes for a short life span; not an archival medium • Quality decreases with each successive generational copy • Fragile and short-lived • Short-lived • Must be migrated (recopied) and refreshed (rewound) every 5 years
Digital video	<ul style="list-style-type: none"> • Digital format • Can make copies without any loss of quality; copies as good as the original • Superior image quality over analog format 	<ul style="list-style-type: none"> • Fragile; is not an archival medium • Expensive to maintain • Must be migrated and refreshed every 5 years

5. *When is it appropriate to produce a video in-house?*

Video is an excellent tool to document storage conditions, damage such as leaks or vandalism, contract work and exhibits installation and removal. You also can use it to do a park history or record staff expertise. You can videotape using a VHS, 8mm, or Hi8 camcorder that has a camera, recorder, and playback mode and allows you to review tape footage readily.

A video inventory of the collection area is useful for individual objects, but video quality doesn't match that of high-quality still images. Video has poor resolution and a short lifetime compared to still images. Unlike still images, it is a poor archival medium, because it wears out after a few years, when the metal particles detach from the plastic backing.

You should use videotape only to document speeches or panels if you have good equipment such as lighting, miking, and multiple cameras, and a skilled person taping the show. If you don't have the necessary equipment and experience, you should contract with a professional.

6. *When is it appropriate to work with a professional?*

If your video is intended for professional or public outreach and will be viewed by the general public, you should work with or hire a professional. Film and video production is a specialized skill. Don't consider this kind of production without funding.

7. *How do I select a film or video maker?*

Find a production company or media producer experienced in your subject. The most important factor in selecting film or video producers is to see recent examples of their work. Read reviews of the producer's work. Wherever possible, select the producer based on the staff he or she brings to the project.

8. *How do I negotiate with a film or video maker?*

Develop a scope of work, budget, and schedule, and draft the contract and product specifications. All contracting must be handled through your contracting office. Consult with HFC-AV to get information on what should be covered in the negotiations.

9. *What are the steps involved in production of a film or video?*

As the project manager, you need to ensure the steps noted below are completed by qualified professionals.

- ***Write a Scope of Work.***

Outline what the film or video will accomplish, a message summary, the audience, length, delivery system, and format.

- ***Develop a budget and schedule.***

Identify cost, cast, crewmembers, and establish production schedule and phased delivery dates.

- ***Write a treatment.***

Outline what information is to be included, how it will be communicated, length of finished video.

- ***Write a script.***

Approve, review, and revise as needed.

- ***Outline a shooting schedule.***

Show who will do what, when.

- ***Identify a location for shooting and recording.***

- ***Edit footage.***

- **Review the rough cut.**

Review, revise, and approve.

- **Produce a fine cut (final product).**

- **Produce or obtain the deliverables.**

Obtain the finished film or video, negatives, large format masters plus all raw footage.

- **Distribute and market the film or video.**

10. *What is the Harpers Ferry Center - Audiovisual Division (HFC-AV)?*

The Harpers Ferry Center-Audiovisual (HFC-AV) Division provides AV support, ranging from planning advice to producing a show. They can advise you on various formats, equipment, and technical specifications. They can assist in evaluating proposals and potential contractors. Consult with the Division on all aspects of your project when you start planning. You can reach them at (304) 535-6081.

HFC-AV recommends the use of standardized equipment throughout the NPS. This equipment can be acquired through the HFC-AV Equipment Depot. If purchased through the Depot, the HFC-AV department will repair or replace this equipment.

S. Producing Multimedia

1. *What types of multimedia publications exist?*

Three major kinds of multimedia publications are available:

- **World Wide Web sites** (Web sites), which are on the Internet, can integrate images, texts, links to other sites called hyperlinks, video recordings, sound recordings, and animated icons.
- **Compact Discs** (CDs) come in a variety of formats including CD-ROMs (compact disc read only memory); CD-R (compact discs-recordable), rewritable CDs, and WORM CDs (Write Once Read Many Times), which can contain video, hyperlinks, sound recordings, and animation; CD-DA (Compact Disc Digital Audio), which are popular music carriers; and DVD discs (digital versatile discs, also known as digital video discs), which are popular carriers for videos and motion pictures.
- **Hybrid publications** are contemporary publications that can be mounted on CDs with updates to the publications placed on a Web site over time. This allows for a distributable product that can be kept updated daily and periodically, and allow you to use the major advantages of both formats of multimedia.

2. *How do I plan and develop multimedia publications?*

Plan a multimedia publication much as you would any other publication. See the Master Checklist for Publication Project, Figure 3.13.

3. *What resources will I need?*

To produce a good multimedia publication you will need:

- *expert multimedia designers and layout people*
- *coding experience* for preparing links to other sites and pages
- *scanning and software skills* for scanning and retouching images, sound files, text, and video or contract monies to have this done outside
- *topically expert writers and editors* experienced writing information for multimedia in brief, pithy text, and active voice
- *knowledge of legal issues*, particularly when, how, and why to obtain permissions for intellectual property rights such as copyright, privacy, and publicity concerns.
- *permission and/or fees* for quotes and images
- *appropriate hardware and software*

4. *What is the vocabulary of multimedia?*

Multimedia has its own jargon. To work effectively in the field, you should know terms defined in *MH-III*, Appendix A.

5. *What are the advantages and disadvantages of these multimedia formats?*

For an overview of the various advantages and disadvantages of the three formats see the following charts.

Advantages and Disadvantages of Multimedia Publishing Formats		
Format	Advantages	Disadvantages
CDs	<ul style="list-style-type: none"> • Compact: CDs, like microfilm, can hold huge amounts of data in a small space. • Inexpensive: CDs cost only a few dollars to press. The rapidly rising cost of paper can be avoided by distributing in CD format. • Searchable: CDs are one of the first fully searchable storage media, making them attractive to researchers. • Transferable: Can be copied and compressed without generational loss. • Self Correcting: Can contain EDAC (error detection and correction systems) • A True Multimedia Format: Widely used to distribute software, music and other sound files, images, videos, and text. 	<ul style="list-style-type: none"> • Not Updateable: Most CDs, like microfilm, can't be readily updated. • Changing Formats: Most CD equipment only plays certain types of CDs. You must refresh and migrate CDs because software and hardware change frequently. • Not Necessarily Long Lived: While most manufacturers promise 100s of years of life for CDs, they only warranty their CDs for 10 years. • Require Migration: CD contents must be migrated to new formats as software and hardware changes or they will be lost. • Damage Easily: CDs fail fast when handled roughly, primarily because of physical stress leading to delaminating, warping, scratching, yellowing of the plastic, oxidation of the aluminum layer. High humidity can make a CD unplayable. • Sells Poorly: Cultural CDs produced by museums, historical organizations and archives have sold poorly, leading to a great retreat from their production and sales recently. Games sell well.

Advantages and Disadvantages of Multimedia Publishing Formats		
Format	Advantages	Disadvantages
Web	<ul style="list-style-type: none"> • International: Used internationally in schools, businesses, government, and the entertainment industry. • Inexpensive: The major costs of the Web are in the publication preparations, such as writing, editing, and design, thus skipping the cost of paper, printing, shipping, and advertising. Use of the Web is free. • Searchable and Linkable: The Web is fully searchable and sites can be linked together with hypertext to lead to a fully interactive non-linear learning environment. Web sites can also be linked to CDs so that a hybrid system is produced in which unchanging data rests on the CD and updates are linked to the CD and placed on the Web. Viewers can seamlessly navigate between the two at the click of a mouse. • Easy to Update and Change: Doesn't require new editions, just a few changes in code and materials to change a site. • Multimedia Format: Provides access to still and moving pictures, and sound clips. Has capability to display 360-degree panoramic images. • Reaches Masses: Used by over 40+ million readers regularly, including schools, offices, organizations, and many homes. Reaches large numbers of the public who might never visit national parks. Provides NPS information about resources to the public. Allows for planning trips and research not ever provided before. 	<ul style="list-style-type: none"> • Limited Access: Many schools, libraries, corporations, and homes lack access to the World Wide Web, or can only handle the text version. However, there is a dramatic increase in access to the Web. • Amateur Quality: Many users assume that because Web work is inexpensive and easy to learn anyone can do it. Much poor quality work goes up on the Web. The Web also requires considerable maintenance and upkeep. • Lost in CyberSpace: Unless your Web site structure is useful, your links helpful, your content rich and accurate, and your pages well identified, you will rapidly lose your audience, which can escape from your site with the click of a mouse. • Garbage In and Out: The Web is so easy to produce, a lot of error-ridden garbage appears there. To keep the public's imagination, you must update your site regularly with high-quality content and new features. • Speed: Downloading can take a long time and is limited by the user's hardware. • Evaluation Necessary: Much of the public doesn't know how to evaluate the Web's contents, so Web resources often are used inappropriately.

6. *When is it appropriate to produce a Web page or CD-ROM in house?*

Produce a Web page or CD-ROM publication in house when all of the following apply.

- You have the appropriate design, writing, coding, and editing skills.
- You have permission from your supervisor, superintendent, and publications officer.

- You have contacted your park Web specialist, center, or program about mounting your materials and maintaining access to your subdirectory, as well as your cluster Web coordinator.
 - You are aware of the legal issues involved in such work and have obtained all necessary permissions.
 - You have the time, energy, skill, training, experience, and resources to do it well and update it regularly.
7. *What do I need to know to produce a museum collections Web site?*
- To produce a museum collection site you need:
- html coding, including knowledge of metadata to facilitate search engines in finding and indexing your site
 - the basics of multimedia design and layout (look at other sites to see a range of solutions), and accurate, interesting, and well-written information
 - high quality visuals and sound files
8. *How do I produce a museum collections Web site?*
- Follow the steps in the Figure 3.1, Master Checklist for Publication Project.
9. *What do I need to know to produce a CD-ROM?*
- The skills are the same as for Web sites, but you must also:
- develop an advertising and marketing plan for the finished product
 - determine what operating system your CD will use
 - determine if you want your product to link to a Web site as a hybrid CD
10. *How do I produce a CD-ROM?*
- You can use CDs as back-up files to document Web sites or as publications. CD-ROMs can be produced by downloading a Web site to a CD to make a permanent copy. For commercial CDs, you should follow all the standard publication steps described for Web publishing. When a publication-quality CD is desired, follow the Web publishing process above, but add a marketing and packaging step after publication to ensure the publication reaches the widest audience.
11. *What is an online order fulfillment service?*
- An online order-fulfillment service is an electronic stock image agency or image bank that provides image, video, or sound files to publishers, authors, and filmmakers for a fee.
- Many contemporary agencies provide watermark-protected thumbnail (small) images of the files over the World Wide Web and allow clients to purchase materials electronically through telephone or Internet-based funds transfer. A watermark is a marking system built into the image.

When online order fulfillment services ask to incorporate your materials, they generally expect to profit from them. Be careful not to give these groups copyright, privacy, publicity law protected images, or exclusive licensing. Commercial use of these materials carries stringent penalties. See *MH-III*, Chapter 2, Legal Issues.

You might investigate the possibility of all sales generating a small royalty to be given to your cooperating association for preserving the park's collections, or to fund new digital publications.

12. *How do I negotiate with potential order fulfillment services and multimedia publishers?*

Familiarize yourself with the legal and ethical issues described in Chapters 1 and 2 of *MH-III*. Read the Digital Publication Project Checklist, Figure 3.11, for a summary of issues. Ask to see copies of the contracts used by the corporation when dealing with private and public museums, archives, and libraries, and when negotiating directly with photographers. Determine cost recovery, what level of initial payment, credit line, caption and context control, and other control you will have. Get the offer in writing.

Don't agree to exclusive or perpetual licensing arrangements with order fulfillment services or multimedia publishers.

Work with the contracting office, the SO curator, and the NPS solicitor to consider the contract or agreement. Remember that equal access is a fundamental principle.

13. *How do I select a multimedia publisher or producer?*

Select a multimedia publisher or producer the same way you select a publisher or producer. Research who is producing material on your subject. Read their reviews. Check the products they have produced. Ensure their work is done with qualified discipline specialists, rather than programmers. Talk to discipline specialists and multimedia bibliographers for recommendations.

T. Producing Sound Recordings

1. *How do I plan and develop a sound recording?*

The steps you take to plan and develop a sound recording are similar to those you take in doing any publication. You should:

- identify the purpose of the recording
- identify your audience
- outline theme(s) and major points or programs
- develop a budget and schedule
- select a producer/project manager

- select the recording format
- select art and design work, if appropriate
- prepare and edit the script or program
- select a narrator, performer(s) or musician(s)
- obtain all necessary permissions
- tape the narrator, performer(s) or musician(s)
- review the recording
- edit and mix the recording
- produce a master in digital format with working copies and appropriate labels
- duplicate the recording
- market and distribute the recording

Once you've identified the purpose of the recording project, you should ask the following questions.

- Is it for in-house training or informational purposes only?
- Will it be used for visitor education?
- Will it be used for general distribution?

Answers to these questions, combined with your budget will allow you to make appropriate plans to record and produce a sound recording.

2. *What resources will I need?*

To produce a good sound recording publication you'll need:

- subject matter specialists, writers, editors or narrators, performers such as musicians or singers
- recording equipment
- recording engineers and editors
- knowledge of legal issues and how to obtain permission for recording and performance rights

You should contact the HFC-AV for additional information on technical sound matters.

Consider the following when developing the budget:

- script or program preparation (writing and editing)
- outside director or producer fees, if used
- creation and recording of custom music
- creation of artwork for cover and inserts, if used
- reproduction rights and cost to use other recorded material
- recording studio time
- mixing and sound editing
- printing and duplication
- marketing

3. *What are the major types of audio formats?*

The major types of audio formats include:

- cassette
- microcassette
- 1/4" reel-to-reel
- CD (compact disc)
- minidisc
- DAT (digital audio tape)

4. *What are the advantages and disadvantages of these formats?*

See the following chart.

Major Advantages and Disadvantages of Sound Recording Formats		
Format	Advantages	Disadvantages
Cassette	<ul style="list-style-type: none"> • Widely used delivery format; can also be used for sound capture (recording) • Excellent for lectures, music distribution and transcription • Portable and easy to store • Available everywhere • High-bias tape with Dolby noise reduction gives excellent results, especially when working with music 	<ul style="list-style-type: none"> • Analog format has lower fidelity (audio quality) than a CD; tape hiss and noise • High maintenance • Relatively limited life span; not an archival medium • Not recommended for repeat playback due to rewind time and tape life • Loses quality with repeated use
Microcassette	<ul style="list-style-type: none"> • Used primarily for dictation and transcription • Trouble-free field recording of the voice • Compact size • Convenient 	<ul style="list-style-type: none"> • Extremely low audio quality and short lived; not an archival medium. • Not suited for music • Not as widely used as the standard cassette and not used by production professionals • Equipment not widely available
1/4" Reel to Reel	<ul style="list-style-type: none"> • Sound quality as good as or better than cassette • Durable • Commonly used in studio work 	<ul style="list-style-type: none"> • Equipment is expensive and not commonly available • More expensive to copy • Tape stock is more difficult to obtain
Compact Disc (CD)	<ul style="list-style-type: none"> • Excellent delivery system • Provides the highest quality for music and voice recordings • Ideal format for repeat playback necessary in exhibitions • Format of choice for popular music distribution and sale 	<ul style="list-style-type: none"> • Higher costs than cassette for mass production • Not an archival medium; refer to <i>Conserve O Gram</i> 19/19, Care of Archival Compact Disks • More difficult to move (migrate) to new formats • Formats can change and are not compatible so older CDs become unplayable
Digital Audio Tape (DAT)	<ul style="list-style-type: none"> • Digital format used by professionals • Used for production purposes and mastering with no loss of quality • Has CD quality 	<ul style="list-style-type: none"> • Not an archival format • Not as durable as CDs • Not yet tested by conservators for durability

Major Advantages and Disadvantages of Sound Recording Formats		
Format	Advantages	Disadvantages
Minidisc	<ul style="list-style-type: none"> • Excellent sound quality • Easy to edit and access tracks • Good repeat playback • Compact 	<ul style="list-style-type: none"> • Not yet tested by conservators for durability • Relatively new format, equipment and titles not as available as CD or cassette • May not be playable when the format changes • No industry standard

5. *When is it appropriate to produce a sound recording in-house?*

Produce a sound recording in-house when you have:

- appropriate writing and editing skills or narration, performance or musical skills
- to make the recording for information purposes only
- sound recording equipment and know how to use it
- authorization from your supervisor, superintendent and publication coordinator
- familiarity with legal issues and have obtained all necessary permissions

If you're interested only in the informational value of the sound recording for in-house use, you don't need special skills to record an interview or tape an oral history. You can get good results by using a quality hand-held cassette recorder or a desktop unit with one or two good microphones.

Practice with the equipment until you're comfortable, and then do the final taping. Rehearse the material whether it's a script or music, but not for an oral history interview, before you record. You should record several versions so that you can select the best one.

However, if you plan to use the recording for an audio, video or film production, you should use the services of a professional sound engineer and professional recording equipment. This includes a high quality professional microphone and tape recorder with monitoring during recording capability. Contact HFC-AV at the beginning of your project. HFC-AV will give you information on formats, sound engineers, equipment, and duplication services.

6. *When can I use historic recordings or instruments?*

Many available historic recordings and instruments are not pristine, but this shouldn't be the overriding factor in deciding whether to use them. A scratched old recording of a historic event or person, such as Thomas Edison, adds feeling, color, and dimension to a soundtrack.

Sound engineers have discovered useful information in background noise on older recordings. Don't automatically wipe this information out when you migrate your sound recordings to a new format.

Take great care when handling these materials. If the sound is good enough, work from duplicates whenever possible. Old recordings can be restored, but this is an expensive undertaking. Consult your SO curator, a conservator, and staff at the HFC-AV.

7. *What must I do to locate a good sound publisher?*

Contact HFC-AV for information on locating a good sound publisher, or for any other sound recording questions you have. Get recommendations from local museums, television and radio stations, and other organizations. Find out who published a product you like and call them for information. You also can access information on the Internet.

U. Identifying and Developing Special Skills

1. *What skills are required to produce sound and multimedia publications?*

The same skills are necessary for all publications: research, fact-checking, writing, editing (both substantive editing and copyediting), and design and layout. The only new skill required is mastering the technical aspects of the publishing, such as html coding and online proofreading. When these skills are added to a thorough knowledge of your audience, you can produce an excellent publication, regardless of the medium.

2. *How do I learn to produce NPS publications?*

Obtain training and experience by:

- taking courses at your local university
- working alongside partners or contractors trained in this area
- working first on small projects, then taking on more significant publications as you gain expertise
- if producing a paper publication, working with your regional printing coordinator
- if producing a Web publication, working with your region's Webmaster
- reviewing a broad range of NPS publications
- reviewing museum publications from all sources
- consulting with appropriate HFC-AV and Denver Service Center (DSC) staff as you start planning your publication.

3. *What do I look for when reviewing resumes and portfolios of non-NPS publication contractors?* Look for long-term experience, especially experience specific to your project. Ask for copies of their work. Read reviews in appropriate publications. Ask your local librarian to help you find publication reviews. You must work with your contracting officer to hire any contractors.
4. *How do I contract or partner?* You must work with your contracting office, SO staff, and supervisor to arrange for partnerships, memoranda of agreements, or cooperative agreements. The formats and requirements for these documents and agreements vary over time. See examples of some current contracts and agreements in the figures section, for example, Figure 3.5, Cooperative Publishing Agreement, and Figure 3.12, Memorandum of Agreement. This work probably will require a scope of work, a contract, bids, and personnel selection.
5. *What is a scope of work?* A scope of work is a document that lists the tasks, responsibilities, and activities involved in a particular job or area. The tasks listed under each type of publication in this chapter are the basic activities you would be listing and assigning to staff in a scope of work.
6. *What is a contract?* A contract is a legally binding agreement between two parties that states what each party will do and when. All NPS contracts must be processed through the contracting office. Provide the contracting office with a draft contract outlining the details of what is required, deliverables (products), work, and payment schedule.
- The Contracting Officer (CO) finalizes and issues the contract. You may be designated, in writing, the Contracting Officer's Technical Representative (COTR) by the CO. As COTR you assist in the administration of a contract under the provision of the DOI Acquisition Regulation (DIAR) 1401.670.2 and as outlined in the letter of designation. The COTR is not empowered to:
- award, agree to, or sign any contract (including delivery or purchase orders) or modification of any contract
 - obligate the payment of money by the government
 - make a final decision on any contract matter concerning a dispute
 - terminate for any cause, the contractor's right to proceed
 - take any action that may have an impact on contract or schedules, funds, or scope of work
- All contractual agreements, commitments, or modifications that involve prices, quantities, quality, or delivery schedules can only be made by the CO. Work with the CO to authorize payments after the satisfactory products(s) have been delivered.
7. *Who handles bids?* Your CO handles all aspects of the bid process.

8. *How do I market my publications?*

You can market your publication by:

- providing review copies to high-profile reviewers, such as *Library Journal*, *Choice*, and *College and Research Libraries*
- providing your publisher with a complete list of journals that should receive review copies
- providing your publisher with a complete list of likely reviewers
- sending out announcements to mailing lists of your professional organizations
- posting announcements on discipline specific "listservs" and electronic bulletin boards
- purchasing advertising in journals and newsletters
- placing handouts on announcement tables at professional organizations
- asking colleagues to submit the work for publication awards
- placing ads in your professional journals to alert colleagues to the publication
- issuing press releases upon publication to key newspapers and journals
- posting announcements and messages about the publication on Internet bulletin boards and listservs
- sending announcements of Web publications and appropriate index terms to appropriate search engines
- including good descriptive terms and metadata in the file headers of the NPS Web site to help the work of search engines.

V. Annotated Selected Bibliography

- Able, Edward H., Jr. "Publish or Perish." *Museum News* 72, no. 4 (1993): 71.
- American Association of Museums. *American Association of Museums Bookstore Catalog* (Annual). American Association of Museums, 1575 Eye Street NW, Suite 400, Washington, DC 20005. (A catalog of publications available from the AAM; includes several titles on publishing).
- Bailey, Edward P., Jr. *The Plain English Approach to Business Writing*. New York: Oxford University Press, 1996.
- Barzun, Jacques, and Henry G. Graff. *The Modern Researcher*, 3rd ed. New York: Harcourt, Brace, and Jovanovich, 1986.
- Beach, Mark. *Graphically Speaking: An Illustrated Guide to the Working Language of Design and Printing*. Manzanita, Oreg.: Elk Ridge Press (distributed by North Light Books, Cincinnati), 1992. (A good reference book; includes a Spanish index.)
- Beach, Mark, and Kathleen Ryan. *Papers for Printing: How to Choose the Right Paper at the Right Price for all your Design and Printing Needs*. Portland, Oreg.: Coast-to-Coast Books, 1991. (A great resource for understanding different kinds of paper and how they can be used in a publishing project.)
- Beach, Mark, Steve Shapiro, and Ken Russon. *Getting it Printed: How to Work with Printers and Graphic Arts Services to Assure Quality, Stay on Schedule, and Control Costs*. Portland, Oreg.: Coast-to-Coast Books, 1986. (A good, useful overall guide to planning and producing a publication; includes copy-ready forms for planning jobs and writing specifications.)
- Books in Print*. New York: R. R. Bowker, 1997.
- Brandenburg, Aliko Liacouras. *How a Book is Made*. Harper and Row, Harper Trophy Book, 1988. (A well-illustrated children's book about publishing and printing; good overview.)
- Brown, Osa. "Partners in Print: A Co-Publishing How-To." *Museum News* 72, no. 4 (1993): 46-47 and 61-62.
- CD-ROMs in Print*. New York: R. R. Bowker, 1997.
- The Chicago Manual of Style for Authors, Editors and Copywriters (14th edition)*. Chicago: University of Chicago Press, 1992. (The NPS advises using *The Chicago Manual of Style* as the standard for writing and editing.)
- Felici, James. *The Desktop Style Guide: The Comprehensive Reference for Creating Professional Documents on the Desktop*. New York: Bantam Books, 1991.
- The Foundation Center. *Grants for Libraries and Information Services*. Washington, D.C.: The Foundation Center, 1996.
- Hale, Constance, ed. *Wired Style: Principles of English Usage in the Digital Age*. San Francisco, Calif.: Wired Books, 1996.
- Hopkins, Bruce, ed. *Information Design: Tools and Techniques for Parks*. Philadelphia and Bozeman, Mont.: National Park Service, 1997. (The published proceedings of a 1995 NPS workshop on desktop publishing, with sections on designing, writing, editing, working with print shops, and Web publishing.)

Hudson, Chris. "Publishing with Partners: The Museum's Perspective." *Journal of Scholarly Publishing* 26, no. 2 (1995): 129-137.

International Paper Company. *Pocket Pal: A Graphic Arts Production Handbook*. New York: International Paper Company, 1989. (Revised every few years.)

Kerabian, Helen, and William Padgett. *Production of Museum Publications: A Step-by-Step Guide*. New York: Gallery Association of New York State, 1989. (Very good; available from AAM.)

Krebs, Arlene, ed. *Distance Learning Funding Source Book*. Dubuque, Iowa: Kendall/Hunt Publishing Co., 1996.
Kremer, John. *101 Ways to Market Your Books, for Authors and Publishers*. Fairfield, Iowa: Ad-Lib Publications, 1984.

Laing Research Services. *Publishing Partners: Plans and Pro Formas for Museums, Associations, Institutions and Their Publishing Partners* (the Business of Publishing Monograph). Redmond, Wash: Laing Communications, Inc., 1991. (Available from AAM; provides different ways of looking at publishing options and evaluating their financial viability.)

Lee, Marshall. *Bookmaking: The Illustrated Guide to Design, Production, Editing*, 2nd ed. New York: R. R. Bowker, 1979. (A well-written, illustrated book on the mechanics of bookmaking.)

Lem, Dean. *Graphics Master 3: A Workbook of Planning Aids, Reference Guides and Graphics Tools for the Design, Estimating, Preparation and Production of Printing and Print Advertising*. Los Angeles, Calif: Dean Lem Associates, 1983. (Good, concise, easy-to-use reference guide; includes useful charts and typeface samples.)

National Park Service. *Design Specifications, National Park Service, Informational Folder Program*. (pamphlet) Harpers Ferry, W.Va.: National Park Service, n.d.

_____. *Natural Resources Publication Management Handbook*. Washington, D.C.: National Park Service, 1991. (Chapter 5, "Manuscript and Production Standards," and Chapter 6, "Printing and Publication Processes," are particularly pertinent and useful, even for non-Natural Resource publications.)

_____. *Cultural Resource Management Guideline (formerly NPS-28)*, Washington, D.C.: National Park Service, 1997. (See appendices for additional bibliographies and cultural resources reports.)

_____. *Supplementary Graphics Systems, National Park Service, U.S. Department of the Interior* (pamphlet): Harpers Ferry, W.Va.: National Park Service, n.d.

_____. ParkNet Web Publication Guidelines. <<http://www.nps.gov/helpdesk/>>

National Research Council. *Science and the National Parks*. The Committee on Improving the Science and Technology Programs of the National Park Service. Washington, D.C.: National Academy Press, 1992. (Discusses the importance of research for the National Park Service; includes a good bibliography pertaining to science in the parks.)

Publishers, Distributors, & Wholesalers of the United States, 1997-1998. New York: R. R. Bowker, 1998.

Rossen, Susan F. "Beyond Vanity: A New Era for Museum Publishing." *Museum News* 72, no. 4 (1993): 44-45 and 59-62.

Rossen, Susan F. Preface: "Publishing in Museums." *Journal of Scholarly Publishing* 26, no. 2 (1995):

103-105. (This issue of the *Journal of Scholarly Publishing* distills presentations from the last two years of the Museum Publishing Seminars.)

Rubens, Philip. *Science and Technical Writing: A Manual of Style*. Markham, Ontario: Henry Holt and Sons: 1992.

Skillen, Marjorie E. *Words Into Type*. New York: Prentice-Hall, 1974. (A manual covering both general and specifics of grammar, usage, and manuscript production; has comprehensive index.)

Strand, John. "Letter from the Editor." *Museum News* 72, no. 4 (1993): 5.

The Taft Group. *The Big Book of Museum Grant Money* (prepared by The Taft Group for American Association of Museums). Rockville, Md.: The Taft Group, 1995.

Tilden, Freeman. *Interpreting Our Heritage: Principles and Practices for Visitor Services in Parks, Museum, and Historic Places*. Chapel Hill, N.C.: University of North Carolina Press, 1957.

U.S. Department of the Interior. *Ethics and Conduct Information Bulletin: New Standards of Conduct for the Executive Branch*, Bulletin No. 92-1, August 1992. Washington, D.C.: U.S. Department of the Interior, 1992.

_____. *Ethics: An Employee Guide*. Washington, D.C.: U.S. Department of the Interior: Division of Printing and Publications, 1993.

U.S. Office of Government Ethics. "5 CFR Part 2635: Standards of Ethical Conduct for Employees of the Executive Branch; Final Rule. Friday, August 7, 1992." *Federal Register* 57, no. 153 (1992): 35006-35067.

Vogt-O'Connor, Diane. *Report on Funding Possibilities for the National Park Service Education Initiative*, Washington, D.C.: National Park Service, 1998.

Wilson, Adrian. *The Design of Books*. San Francisco, Calif.: Chronicle Books, 1993. (Discusses the artistry of design and the importance of good design.)

Zinsser, William. *On Writing Well: An Informal Guide to Writing Non-Fiction*. 2nd ed. New York: Harper and Row, 1980. (Gives useful pointers on style and usage for writers.)

_____. *Writing to Learn*. New York: Harper and Row, 1988. (Author states his purpose is to take the fear out of writing for science-minded people, and to take the fear out of science for humanities-minded people.)

W. L. List of Figures

Figure 3.1	Master Checklist for Publication Project (Sample) [Optional].....	3:72
Figure 3.2	Intellectual Property Permission Request (Sample) [Optional]	3:75
Figure 3.3	Research Sheet (Sample) [Optional].....	3:76
Figure 3.4	Assignment of Copyright by Contractor (Sample).....	3:77
Figure 3.5	Cooperative Publishing Agreement (Sample) [Optional].....	3:78
Figure 3.6	Model Release Form 1	3:80
Figure 3.7	Model Release Form 2	3:81
Figure 3.8	Paper Printing Job Organizer (Sample) [Optional].....	3:82
Figure 3.9	Museum Management Program Editing Checklist (Sample) [Optional].....	3:84
Figure 3.10	Museum Management Program Proofreaders' Checklist (Sample) [Optional].....	3:87
Figure 3.11	Digital Publication Project Checklist (Sample) [Optional].....	3:89
Figure 3.12	Memorandum of Agreement (Sample) [Optional]	3:97
Figure 3.13	Selected Foundations that Fund Publications	3:101

Master Checklist for Publication Project

Project Name: _____ Date: _____

Reviewer: _____

	<p>Audience:</p> <ul style="list-style-type: none"> - Have you defined the project audience, including level, interests, and geography?
	<p>Message:</p> <ul style="list-style-type: none"> - Have you defined the project message clearly in a paragraph including the Who, What, Where, Why, When, and How of the topic? - Have you checked the message via discipline specialists and peer review?
	<p>Specifications:</p> <ul style="list-style-type: none"> - Have you selected the project's media or publication format based on its advantages and disadvantages? - Are the project size, format, illustrations, and other media indicated? - Do you have a sample section? - Did you decide what special contents to include, such as front and back matter? - Have you started planning your marketing?
	<p>Budget:</p> <ul style="list-style-type: none"> - Have you developed a project budget? - Have you obtained bids for production work, such as typesetting, printing, and binding? - Have appropriate internal resources been found? - If not, has external funding been located, such as foundation funding? - Have you investigated working with a partner or an existing external press that might underwrite the publication?
	<p>Participants:</p> <ul style="list-style-type: none"> - Have you selected authors, editors, designers, layout staff, a publisher, and other participants based upon their experience and skills? - Have you filled subject expertise gaps by bringing in qualified outside partners or contractors? - Are necessary contracts or cooperative agreements in place?
	<p>Schedule:</p> <ul style="list-style-type: none"> - Have you developed a project schedule? - Is the schedule reasonable? - What elements might lead to delays?
	<p>Research:</p> <ul style="list-style-type: none"> - Has the project research been completed? - Did you consult discipline specialists and university library bibliographers? <ul style="list-style-type: none"> - Have you consulted a wide array of reputable sources, including recent well-reviewed articles and book sources? - Did you use a style sheet of materials requiring fact checking?

- 1.
2. *Figure 3.1. Master Checklist for Publication Project*

Master Checklist for Publication Project	
Project Name: _____ Date: _____	
Reviewer: _____	
	<p>Image and Quote Selection:</p> <ul style="list-style-type: none"> - Has the external content been selected or created, such as artwork, photographs, and contract writing, etc.? - Has the work been edited and reviewed? - Have revisions been made as necessary? - Did you take good notes for captions and permission solicitation?
	<p>Legal Issues:</p> <ul style="list-style-type: none"> - Have you sought permission for all quoted or reprinted materials including copyrights, privacy permissions, publicity permissions, etc.? - Have you received permission in writing to use all protected materials being published? <ul style="list-style-type: none"> - Have you avoided publishing location information on archeological sites, protected caves, and endangered species?
	<p>Ethical and Cultural Issues:</p> <ul style="list-style-type: none"> - Have you consulted with any associated groups who might be directly affected by your publication? - Did you work with the associated groups to resolve differences and difficulties? - Do all associated groups know what will be published and why?
	<p>Planning:</p> <ul style="list-style-type: none"> - Have you outlined your publication and produced storyboards for all videos, Web sites, and CDs? - Have you obtained peer review for these outlines and storyboards? - Did you correct any problems discovered during peer review? - Did you select a style manual?
	<p>Design:</p> <ul style="list-style-type: none"> - Have you planned the format and design of the work? - Has the design received peer review to determine if it is appropriate and helpful for the work? - Has any necessary artwork been produced and reviewed? - Are captions completed for all artwork? - Were all storyboards reviewed and potential links indicated?
	<p>Writing:</p> <ul style="list-style-type: none"> - Have the authors written their text? - Has the text received peer review? - Were necessary changes made? - Did you develop a style sheet containing information to be fact-checked? - Has all fact-checking occurred? - Were factual revisions inserted into the text appropriately? - Are the final results clear, consistent, and useful?

3. Figure 3.1. Master Checklist for Publication Project (continued)

Master Checklist for Publication Project	
Project Name: _____ Date: _____	
Reviewer: _____	
	<ul style="list-style-type: none"> - Do you have a table of contents? - Do you have a bibliography? - Do you have an index? - Do you have appendices? - Are the appropriate people credited and acknowledged?
	<p>Editing:</p> <ul style="list-style-type: none"> - Have you completed a substantive edit as listed in the checklist? - Have you made all resulting changes to the text? - Did you edit for style as listed in the checklist? - Did you make all resulting changes to the text? - Did the text receive a peer review for content? - Did you make all resulting changes to the text? - Have you sent the final edited version of the text to the printer? - Have you edited and checked all front and back matter? - Have you checked all headers and footers and equivalent matter?
	<p>Proofreading:</p> <ul style="list-style-type: none"> - Has the proofreading been done as listed in the proofreader's checklist? - Did you make all resulting changes to the text?
	<p>Mechanicals Review:</p> <ul style="list-style-type: none"> - Have you reviewed the mechanical or preliminary electronic text per the proofreader's checklist? - Did you make all resulting changes to the text?
	<p>Bluelines or Final Electronic Publication Review:</p> <ul style="list-style-type: none"> - Have you reviewed the bluelines or final electronic text per special instruction on the proofreader's checklist? - Did you make all resulting changes to the text?
	<p>Final (Binding or Mirror Site) Check:</p> <ul style="list-style-type: none"> - Did you check the final version (such as the binding)? - Was the mirror site in perfect form for release on the World Wide Web? - Did you make all resulting changes as required?
	<p>Marketing:</p> <ul style="list-style-type: none"> - Have you sent review copies as stipulated? - Did you mail announcements to likely libraries? - Have you displayed the book at book fairs and conferences? - Did you advertise in appropriate journals? - Did you title and create metadata for your Web site for use by search engines?

Figure 3.1. Master Checklist for Publication Project (continued)

Intellectual Property Permission Request

Corporate Name
Permissions Department
Address

Dear:

I am writing to request permission to reprint the following items from your publication:

Author/Title of Publication or Name of Web site
Page Numbers or URL of Web site:
Other Information:

We would like to reprint the materials as published originally in the following work that the National Park Service is preparing for publication:

Author(Editor)/Title/Format/Media/URL (if appropriate):
Proposed Date of Publication:
Comments:

We request nonexclusive world rights, as part of our publication only, in all languages, and in all editions.

If you are the copyright holder, may I have your permission to reprint this material in our book? If you do not state otherwise, we will use the usual scholarly form of acknowledgement, including, publisher, author, and title.

If you are not the copyright holder, or if additional permission is necessary for world rights from another source, please indicate the name, address, and phone number of the individual(s) we should contact.

Thank you for considering this request. A duplicate copy is enclosed for your convenience.

Sincerely,

Superintendent
Name/Signature
Address,
Telephone, Fax, and E-mail numbers

The above request is hereby approved on the conditions specified below, and on the understanding that full credit will be given to the source.

Date: _____ Approved by: _____

Figure 3.2. Intellectual Property Permission Request (Sample) [Optional]

4.

5.

6. *Research Sheet*

**Yucotow National Park
Exhibition Project, 12/1999**

Dates:

1856 or 1865? (date of first fire falls?)

1898 or 1899? (when did Harvey girls come to Yucotow NP?)

Names and Biographies:

Ablestone, Martin M (1850-1923)? or Aablestone, Martine (1853-1920)?

which one was the first park concessionaire?

was Martine Martin's eldest daughter? cousin? paramour?

Subjects:

Brandaise, Muggins or Marjoram? (first superintendent)

Hardpat Falls

When were they first photographed?

When was bridge built?

Who built and why?

Visit of the Secretary of the Interior to the park

When?

Toured which areas?

Length of stay?

Members of his party?

Place Names:

Check spelling of Eleuvian Plateau

What county is Geyserville in?

Cultural groups:

Navaho or Navajo?

Figure 3.3. Research Sheet (Sample) [Optional]

Assignment of Copyright by Contractor

The contract developer ("Developer"), for good and valuable consideration, the receipt of which is acknowledged, grants to the National Park Service ("Client"), its successors and assigns all right, title and interest in the copyright in the work named ("Work") prepared by Developer under its Agreement with Client dated _____.

Developer authorizes the recordation of this notice with the Copyright Office. The copyright registration number/name of the Work is _____.

Description of the Work:

NPS (CLIENT):

DEVELOPER:

Superintendent: _____

Responsible Official: _____

Name/Signature _____

Name/Signature _____

Address: _____

Address: _____

Date: _____

Date: _____

Note: If you are spending governmental money, some required language may need to be included in the contract. This language changes over time. Please check with your contracting office.

Figure 3.4. Assignment of Copyright by Contractor (Sample)

Cooperative Publishing Agreement

NPS Park : _____

Address: _____

City/State: _____

This agreement is made and entered into this ____ day of _____, _____ by and between _____ (National Park Service) _____ ("NPS") and _____ ("Producer") and covers the agreement to last until: _____ (Date).

1. GRANT OF RIGHTS: For the agreed upon cost recovery fee, the receipt and sufficiency of which are hereby acknowledged, National Park Service hereby grants to Producer a nonexclusive agreement to incorporate the Work, into the Production, both as hereinafter defined.

The NPS agreement granted hereunder includes the right to (specify the allowed usages here, for example: edit, telecast, cablecast, rerun, reproduce, use, and digitize) without destroying the historical integrity, dropping the caption, or modifying or compromising the images (specify what you want here). The Producer may (list what you want here, e.g., distribute in one videotape edition or broadcast in perpetuity), the Work, in whole or in part), as incorporated in the Production. Indicate if any Production-related advertising and promotion work is also acceptable.

This agreement specifically excludes the right to use the Work independently of the Production. All usage for advertising and promotion of the work or the NPS name or logo related thereto must be approved separately by the NPS. The rights granted herein shall not confer in the Producer any rights of ownership in the original materials; nor shall it grant the NPS any copyrights in the Production, including, without limitation, the copyright thereto. All copyrights in the original Work remain the exclusive property of the NPS. All copyrights in the Production, remain the exclusive property of the Producer, except that the NPS shall retain copyright in the Work, which the Producer will not copyright or attempt to copyright.

NPS understands and acknowledges that the Production may consist of several different formats of the same Production, each format compatible with a different delivery system of multi-media (by way of example only, a DOS format and a MacIntosh format or for videotapes a Beta format and a VHS format).

2. DESCRIPTION OF WORK: (Format, Subject matter, Content)
_____ (the "Work").

3. DESCRIPTION OF PRODUCTION:

4. CREDIT: In consideration of the rights granted to Producer herein, and provided the Work is used in the Production and the Production is actually released, Producer agrees to give the NPS appropriate credit in the Production in substantially the following form:

Courtesy of: National Park Service, _____ (Park), _____ Collection

Figure 3.5. Cooperative Publishing Agreement (Sample) [Optional]

5. **MONETARY CONSIDERATION:** In further consideration of the rights granted to Producer herein, Producer shall pay to NPS the cost recovery fee of \$_____ per each photographic image, textual page, video frame, or audio statement scanned by Producer. This fee reimburses NPS for handling, labeling, locating, supervising use, and similar work. Producer shall scan all materials on the NPS's premises following NPS access and use policies, procedures, and requirements with Producer's own equipment. Any special requirements by Producer, such as before or after hours access, special support staff assistance, staff research support, or other activities may require additional cost recovery fee payments by the Producer. All resulting cost recovery monies will be paid directly to the park cooperating association (list name) for the direct benefit of the park museum collections.

6. **REPRESENTATIONS AND WARRANTIES:** The NPS represents and warrants to Producer that it has the authority to grant to Producer the rights provided for herein.

7. **ASSIGNMENT:** The NPS acknowledges and agrees that Producer may assign its rights and obligations under this Agreement in whole or in part, subject to the advanced written approval of the NPS. NPS consents herein to Producer assigning for publication and distribution the Production in which the Work will be contained.

8. **GENERAL:** A waiver of any of the terms or conditions of this Agreement in any instance shall not be deemed or construed to be a waiver of such term or condition for the future.

9. **HEADINGS:** The headings at the beginning of each of the paragraphs hereof are for reference only and shall not affect the meaning or construction of this Agreement.

10. **NON-DISCRIMINATION:** The parties agree to be bound by applicable state and federal rules governing Equal Employment Opportunity and Non-Discrimination.

11. **ENTIRE UNDERSTANDING:** The provisions herein constitute the entire understanding between the parties hereto with respect to the subject matter hereof. Any additions to or changes in the Agreement shall be valid only if set forth in writing and signed by the parties.

Accepted for National Park Service:

Name: _____

Title: _____

Signature: _____

Date: _____

Accepted for _____ (Producer):

Name: _____

Title: _____

Signature: _____

Date: _____

Figure 3.5. Cooperative Publishing Agreement (Sample) [Optional] (continued)

Model Release Form 1

I hereby give _____ (National Park Foundation, Association, or Park) the absolute irrevocable right and permission, forever and throughout the world, in connection with the _____
_____ (photographs; videotape; motion picture film; digital sound, imagery or video files; audiotape
interview) taken of me by the National Park Service staff, or in which I may be included with others, the following:

- The right to use and reuse in any manner at all, including distortion, said _____ (photographs,
videotape, motion picture film, digital sound, imagery or video files, audiotape interview) and my name in
conjunction with the caption or text, either whole or in part, either by themselves or in conjunction with other
materials, in any medium including online and for promotional and advertising uses, and other trade, educational,
non-profit, and for-profit purposes, as well as using my name in connection therewith, if (the National Park
Foundation, the Association or Park) so chooses; and
- The right to copyright said materials in the name of _____ (National Park
Foundation, Association, or Park) or in any other name selected.

I forever release and discharge _____ (National Park Foundation, Association, or
Park) from any and all claims, actions, and demands arising out of or in connection with the use of said materials,
including, without limitation, any and all claims for invasion of privacy, publicity, and libel or slander.

This release shall inure to the benefit of the assigns and legal representatives of _____ (National
Park Foundation, Association, or Park), as well as the party(ies) for whom (National Park Foundation, Association, or
Park), created said materials.

I represent that I am over the age of twenty-one years and that I have read the foregoing and fully and completely
understand the contents hereof.

Date: _____

Name: _____

Address: _____

Signature _____

Witness: _____

Address: _____

Figure 3.6. Model Release Form 1 (Sample) [Optional]

Model Release Form 2

Name: _____

Date: _____

Model Release/National Park Service (NPS)

I hereby grant to NPS the absolute and irrevocable right and permission, in respect of the photographs or audio or videotape recordings and their transcripts, that it has taken or has had taken of me or in which I may be included with others, to copyright the same, in its own name or otherwise (and assign my rights throughout the world in such photograph and audio and video recordings and their transcripts), to use, reuse, publish, and republish, and otherwise reproduce, modify and display the same, in whole or in part, individually or with other photographs, and with any copyrighted matter, in any and all media now or hereafter known, for illustration, promotion, art, advertising and trade, or any other purpose whatsoever; and to use my name in connection therewith if it so chooses.

I hereby release and discharge NPS from any and all claims and demands arising out of, or in connection to, the use of the photographs, including without limitation any and all claims for libel or invasion of privacy. NPS may sell, assign, or otherwise transfer all rights granted to it hereunder.

This authorization and release shall also inure to the benefit of the specific park(s), legal representatives and assigns of NPS, as well as the staff representative(s) (if any) for whom it took the photographs.

I am of full age and have the right to contract in my own name. I have read the foregoing and fully understand the contents thereof. This release shall be binding upon me and my heirs, legal representatives and assigns. I further release NPS from any responsibility for injury incurred during the photography or audio or videotaping session.

Signed: _____

Printed Name: _____

Address: _____

City, State, Zip: _____

Phone: _____

Fax Number: _____

Date: _____

Figure 3.7. Model Release Form 2 (Sample) [Optional]

Paper Printing Job Organizer

Project: _____ Coordinator: _____ Date: _____

<i>Function</i>	<i>Person Responsible</i>	<i>Supplier</i>	<i>Date Due</i>	<i>Date Done</i>
Write copy				
Edit Copy				
Proofread copy				
Approve copy				
Make rough layout				
Approve rough layout				
Make dummy				
Approve dummy				
Choose typesetter				
Specify type and mark up copy				
Set type				
Proofread type				
Create illustrations				
Create charts, graphs, maps				
Create and select photographs				
Approve visual elements				
Miscellaneous camera work				

7. Figure 3.8. Paper Printing Job Organizer (Sample) [Optional]

<i>Function</i>	<i>Person Responsible</i>	<i>Supplier</i>	<i>Due Date</i>	<i>Date Done</i>
Choose production artist				
Paste up mechanicals				
Proofread mechanicals				
Approve mechanicals				
Choose or specify trade services				
Make halftones and separations				
Approve proofs of photographs				
Select paper and binding				
Write printing and binding specifications				
Select possible printers				
Obtain bids from printers				
Choose printer				
Contract with printer				
Approve proofs from printer				
Do printing				
Approve press sheets				
Do bindery work				
Verify job done per specs				
Verify charges for alterations				
Verify mechanicals and art returned				
Pay printer and trade services				

8.

9. *Figure 3.8. Paper Printing Job Organizer (Sample) [Optional] (continued)*

Museum Management Program Editing Checklist

Writing Project Editor: Name: _____ Date: _____

SUBSTANTIVE EDIT: Name: _____ Date: _____

- _____ The text completely covers all topics listed in the project outline. Missing sections are noted.
- _____ Research methodology was good; any weaknesses are noted.
- _____ All major issues raised by reviewers and team members are covered; any gaps or missing sections are noted.
- _____ Author's approach to issues reflects NPS and DOI policies, procedures, and guidance; any missing guidance or citations have been added.
- _____ Author's tone and approach to the topic is appropriate; inappropriate sections are marked.
- _____ Facts are substantially correct. Any errors or questionable assumptions are marked.
- _____ Repetitious text was deleted.
- _____ Text is organized rationally; structural flaws are noted with suggestions for improvement.
- _____ Headers, subheaders, and section summaries are logical and clear. Problems are noted.
- _____ Transitions between sections are good. Any sections that flow poorly are noted.
- _____ Writing is clear and coherent. Awkward writing is noted.
- _____ Writing is logical and consistent (non-contradictory). Inconsistencies or poor reasoning is noted.
- _____ Literary style, format, and approach are consistent with the park's program style. Inconsistencies are noted.
- _____ Table of contents is prepared. Inconsistencies between the text and the table of contents are noted.
- _____ Descriptions of figures and tables match the actual figures and tables themselves. Inconsistencies are noted.

PLAIN ENGLISH

STYLE AND FORMAT: Name: _____ Date: _____

- _____ The most important, general, or frequently changed or used subjects are placed first.
- _____ Specific procedures and seldom-used or changed sections are placed in subsidiary paragraphs.
- _____ "You" are the actor implied or spoken to throughout the text.
- _____ Most (95%) verbs are action verbs.
- _____ Sentence and paragraph lengths vary.
- _____ Major sections of the text are parallel or equivalent.
- _____ Question and answer format is used throughout, anticipating the reader's questions.
- _____ Any section with more than 15 subsections is subdivided.
- _____ Table of contents includes lists of questions.
- _____ The first section of the text is called "overview," not "introduction" unless this is inappropriate.
- _____ Main headers, such as section headings, are in mixed case, 10 point Arial bold.

Figure 3.9. Museum Management Program Editing Checklist (Sample) [Optional]

- _____ Secondary headers (questions), have only their first word capitalized and are in 10 point Arial italic
- _____ The text is in 10 point CG Times; the footers are in 9 point CG Times.
- _____ Strings of parallel terms are placed in bulleted lists.
- _____ First level lists use 10 point bullets.
- _____ Second level lists use dashes.
- _____ Italics are used only for numbered section subheadings in the left text column, or for small portions of text.
- _____ Small tables are not boxed, but instead are left hanging in the text.
- _____ Large tables are boxed, but have no internal grid. CG Times italics is used for headers and regular CG Times font for the table's text body.
- _____ Bold and italics are used for emphasis, rather than double bold.
- _____ Titles are capitalized only when they are followed immediately by a name.
- _____ Numbers are aligned along their decimal points when listed vertically.
- _____ The possessive pronoun "your" is not used when referring to people or collections (your superintendent, your museum collections).
- _____ Section references, rather than page numbers, are used in cross-references.
- _____ Quotations are indented in a block and in quotation marks.
- _____ Abbreviations are avoided. If necessary, they are spelled out for the first usage, followed by the abbreviation in parentheses.
- _____ The Latin abbreviations e.g., and i.e., are not used. Instead of e.g., "for example" is used. An explanatory word or phrase in parentheses is used instead of i.e.
- _____ When abbreviating document titles, for example, CMP, periods are not used.
- _____ Two-letter state abbreviations with no periods, for example, MI, are used in addresses, but traditional state abbreviations are used in the bibliography.
- _____ Periods are not used after common bureau and agency abbreviations, for example, NPS.
- _____ The following acceptable abbreviations are used: lf for linear feet, % for percent, RH for relative humidity, and pH for measuring acidity.
- _____ The first word after a colon is capitalized unless it is in the middle of a sentence. **Note:** Graphic style with bulleted lists is NOT considered a sentence.
- _____ A word is capitalized only when it is the first word in a sentence or where emphasis is needed.

COPYEDITING: Name: _____ Date: _____

- _____ Queries and questions on the text are resolved.
- _____ Comments and review suggestions are addressed.
- _____ Author changes, additions, and suggestions are incorporated.
- _____ Fact checking is completed and incorporated.
- _____ Text is clear, concise, and consistent.
- _____ Wordiness is eliminated.
- _____ Tone is proper throughout. No nagging, hectoring, or scolding.
- _____ Grammar is checked.
- _____ Compounding of words is checked.
- _____ Punctuation is checked.
- _____ Spelling is checked.

Figure 3.9. Museum Management Program Editing Checklist (Sample) [Optional] (continued)

_____	Noun/verb agreement is checked.
_____	Active voice is substituted for passive voice where possible.
_____	Figure numbers, math, and textual numbers are checked.
_____	Pagination is checked for accuracy and completeness.
_____	Table of contents is verified against the text.
_____	Titles and subheaders are checked for accuracy and parallel structure.
_____	Running headers and footers are checked.
_____	Pronouns are checked for clear antecedents.
_____	All technical language, including acronyms, is defined and jargon is removed.
_____	Capitalization is checked.
_____	Geographic place names are checked.
_____	Glossaries are checked.
_____	Bibliographies are checked.
_____	All personal and organizational names, titles, telephone numbers, and addresses are verified.
_____	In-text citations are checked for completeness, correctness, and format. (Use <i>Chicago Manual of Style</i> , or the format provided by the editor, such as, Book example: Abel, Peter. <i>Peter Abel's Ethics</i> . Oxford: Clarendon Press, 1971; Journal example: Bran, Mark. "Bran's Brain." <i>Philosophy Journal</i> 33 (1958): 1-19; NPS example: <i>Conserve O Gram</i> 19/10 "Title of the COG." Second Citation of same COG: <i>COG</i> 19/10; Handbook example: <i>Museum Handbook</i> , Part II, Chapter 6, "Title of Chapter." Second citation for same: <i>MH-II</i> , Chapter 6.).
_____	Spacing, layout, and format details are checked.
_____	Illustrations, figures, and tables are reviewed.
_____	All tables are consistent with the proper format.
_____	Figures and tables follow their first mention in the text unless they are placed after the bibliography.
_____	Captions are checked for accuracy, image match, and position.
_____	Manuscript is checked for completeness.
_____	Particular editing problems to watch for with this specific author are listed here and checked (for example, that/which usage; noun/verb agreement; misuse of a particular word or phrase).
_____	All pronouns are checked for clear antecedents; pronouns lacking antecedents are replaced with nouns or the text is rewritten.
_____	Sexist and racist language is removed.
_____	Cross-references are checked.
_____	Manuscript is in <i>Chicago Manual of Style</i> or <i>Plain English</i> format.
_____	Noun strings are broken up.
_____	Smothered verbs are eliminated.
_____	Awkward or confusing sections are noted.
_____	Major organizational problems are noted.
_____	Inconsistencies in style of numbers, words, and compounding are identified.
_____	Use of bold and italics is checked for consistency.
_____	Final Read Behind is completed.

Figure 3.9. Museum Management Program Editing Checklist (Sample) [Optional] (continued)

Museum Management Program Proofreaders' Checklist

- **Special Instructions to Proofreaders:** _____

- **General Notational Instructions for Marking Page Proofs:**

- _____ Mark all printer's errors (deviations from copy, specifications, or standards) with PE.
- _____ Mark all author's alterations (changes from dead copy or specifications made after live copy is prepared) with AA.

- **Notational Instructions for using this List:**

- _____ Mark all queries of any sort with a Q.
- _____ Mark ignored proofing tasks with I on this list as an instruction to ignore this type of proofing.
- _____ Mark jobs to be done with an M.
- _____ Mark completed tasks with a check mark.

- **Proofing Tasks:**

- _____ Query all missing pages.
- _____ Query all blank text.
- _____ Query all breaks in alphabetical sequence.
- _____ Query all breaks in numerical sequence.
- _____ Correct all misspellings and mark as AA.
- _____ Check Table of Contents against text, query any differences.
- _____ Check all tables for capitalization, missing data, punctuation, inconsistencies, misalignment, spacing, and headers; query potential problems.
- _____ Check to make certain that referenced figures, charts, and graphs follow their first mention.
- _____ Check all running heads and footers; query errors, misalignments, or inconsistencies.
- _____ Check all cross-references for accuracy and completeness.
- _____ Check text throughout for dropped copy; query potential problems.
- _____ Check text for widows and orphans of pages and paragraphs.
- _____ Check for word division errors.
- _____ Check for active voice.
- _____ Check for sexist or racist language.
- _____ Check for parallelism in format.
- _____ Check for grammatical errors.
- _____ Check for improper use of italics, underlining, bullets, dashes, and bold.
- _____ Check for compounding.
- _____ Check for capitalization consistency.
- _____ Check for number style consistency.

Figure 3.10. Museum Management Program Proofreaders' Checklist (Sample) [Optional]

<p><input type="checkbox"/> Check for spelling consistency.</p> <p><input type="checkbox"/> Check for abbreviations consistency.</p> <p><input type="checkbox"/> Check for material that makes no sense.</p> <p><input type="checkbox"/> Check for obvious omissions.</p> <p><input type="checkbox"/> Check for incomplete sentences.</p> <p><input type="checkbox"/> Check for oddities of language.</p> <p><input type="checkbox"/> Check for spacing errors in indentation, justification, line spacing, and columns.</p> <p><input type="checkbox"/> Check for mechanical faults such as misaligned characters, broken links, and dirty type.</p> <p>Name: _____</p> <p>Date: _____</p>

**Figure 3.10. Museum Management Program Proofreaders' Checklist (Sample) [Optional]
(continued)**

Digital Publication Project Checklist

Instructions: Use this checklist to remind yourself of the issues you must address in planning a digital publication project or contract. Please check a category when you have addressed it adequately in your planning.

1. Technical Production Issues:

- Production Methods:** Determine how the digitized file will be created, through digitizing:
 - original park collection materials (such as images, sound recordings, videotapes, motion picture films, and documents or books) *or*
 - copies of those materials (such as photographs of objects) which are then digitized, *or*
 - park structures, landscapes, museum collections, and other resources by creating new digital photographs in a digital camera. (If the latter, the work can be done either by park staff or by a contractor. Remember that the creator (photographer) retains the copyrights to his or her images, unless they were produced on work time.)
- Production Needs:** Do high-quality copies exist of the materials to be digitized so the digitizing firm can use those instead of the originals? If not, will the project produce high-quality photographic copies first? If not, will the digitizing work from the originals be done in the park, requiring special set-ups of lights; equipment; security; support staff; or before- or after-hours access, fees or special permits?
- Transportation Needs:** Will the digitizing work be done elsewhere from copies, requiring shipping, packing, and inspection? If not, will the digitizing work be done with loans of original NPS materials, requiring loans of original NPS materials, shipping, packing, insurance, loan, and special handling? If the latter, will a trained collection manager travel with, and be on hand, during digitization to ensure the safety of the materials? If not, can the work be done in the park, where the digitization process can be monitored by park staff?
- Collections Handling:** Is the digitizing firm equipped and trained to follow NPS handling and collections management procedures? Will a staff member trained in materials handling be present during the digitization process to ensure that museum collections are not form-fed through scanners, left under hot lights, or otherwise mishandled?
- Authenticity:** Will the digitizing personnel respect the integrity of the object? The scanner must not modify the appearance of the original except to clarify the information it contains (such as stain removal). Ensure the appearance of the object being digitized will not be significantly altered in any way.
- File Format:** Identify the file format desired for publication. Also indicate the format in which the files will be provided to the park (diskettes or CD-ROMs) and any other publicly available formats used by the digital publisher for any purposes. Determine if any of the formats used are proprietary or restricted use. If so, try to change the format to a non-proprietary format. Does the park have equipment to use this format? Are vendors supporting the equipment and format? If not, propose a different format, such as JPEG or TIF.
- File Size:** Indicate the file size (pixel resolution) you desire. Remember, large files contain the most information. Derivative copy files of various sizes can be made from your large original files. Thumbnail files are desirable as derivatives of your large master file, since they can be viewed speedily from most Web browsers on most systems.

Figure 3.11. Digital Publication Project Checklist (Sample) [Optional]

1. Technical Production Issues (cont.):

- File Descriptive Conventions:** Specify the file naming, numbering, and indexing conventions so that files obtained can be used easily. If the contractor or digitizer produces an index, can the park obtain a copy? What software will be used to manage the images? Can the park obtain the software easily? Will the vendor supply it and support it?
- File Compression:** Will files be provided in a compressed format? Ensure the park is equipped to deal with this format. Is this lossless compression (so that a decompressed image will look the same as one that was never compressed); or lossy (so that it will have a different visual appearance after decompression)? Will the software and hardware needed to decompress the image be available where the image is to be used?
- Captions:** Indicate what information you must provide as captions and credit lines. Determine if you will have to research to write these captions. Will the researcher or publisher underwrite this work? If not, what other work will be set aside? Have you developed a fee schedule for cost recovery, including staff time, benefits, communications costs, and supplies? If not, work with your cooperating association or partners to do so.
- File Preservation:**
 - Ensure permanent and durable media were selected during the file creation stage, such as Kodak Photo CDs, 3-M Super CDs, or Digipress CDs.
 - Ensure digital media will be stored in an appropriate environment (See *Draft Conserve O Gram* 19/19 "Care of Archival Compact Discs" and 19/20 "Care of Archival Digital and Magnetic Media.")
 - Ensure park staff know how to handle and use the media, and that appropriate usage and duplication copies exist.
 - Indicate the file verification and refreshing conventions followed by the publisher during the project life.
 - Indicate when and how file migration will take place.
 - Ensure you have the necessary hardware and software to use the digital file in good condition with appropriate maintenance contracts.
- Identification of Desired Materials:** First identify the items that the researcher wishes to use. Using the criteria of value, use, and risk prioritize items the park wants digitized (see *Conserve O Gram* 19/10, "Reformatting for Preservation and Access: Prioritizing Materials for Duplication"). Encourage the researcher to digitize items that match your collection priorities. If the material is requested by another, insist on a written request with a description of the project. Avoid standard contracts, as they were written to benefit the organization providing them. Once appropriate items are identified, determine if these materials must be denied because of any of the following legal or ethical reasons:

2. Legal and Ethical Issues:

- Copyrights** (17 US Code [USC] 101 et seq., 1987 & Supp V 1993): If the material was not originally produced by the federal government or a federal contractor (and *is* therefore in the public domain) *and* your deed of gift does not give you "all copyrights" *and* the copyright protection has not expired, you may not grant the vendor permission to
 - reproduce
 - distribute copies by sale or transfer of ownership
 - exhibit online
 - prepare derivative works (postcards, CDs, videos, posters) from the materials.

Figure 3.11. Digital Publication Project Checklist (Sample) [Optional] (continued)

2. Legal and Ethical Issues :

Inform the researcher and publisher in writing they must use good-faith efforts to identify the copyright owner and secure written permission to use the protected works. The publisher may have to pay a royalty. The publisher is responsible for obtaining these permissions from the holder of the original copyright, which is not necessarily the NPS. The publisher indemnifies your organization (the NPS) from this responsibility by agreeing to pay for all legal and court costs resulting from lawsuits due to infringements of copyright. Talk to your lawyer.

- Trademarks and Trade names:** Is the item trademarked or trade-named, and would the publication reproduce that trademark or trade name? Will the publisher clear the use of this material with the holder(s) of the original trademarks and trade names? Talk to your lawyer.
- State Privacy Legislation:** Does the item reproduce the home(s), face(s), name(s), fingerprints, or medical, employment, psychiatric, or law enforcement history of a living private individual, family, group, or corporation? Would public exposure of the document place the private individual in a false light, or embarrass him or her? Will the researcher or publisher obtain written permission to use this material from the individuals, groups, or corporations portrayed? Without such written permission, don't provide access to the materials (much less copies) without a subpoena unless your park solicitor advises otherwise.
- Faces and Figures:** If the image, video, or file reproduces a living recognizable private or celebrity individual, group, or corporation, do you have a signed model release form? Tell the publisher in writing that he or she is responsible for obtaining permission to use this material from the individuals portrayed. Ensure the permission obtained matches the proposed usage. If not, don't provide the material for publication or distribution, only for fair use purposes. *Note:* The dead have no right to privacy.
- Interview (5 USC 552a):** If the file reproduces part of an oral history or video history interview, do you have a signed interview release form from all living individuals interviewed or serving as interviewers allowing this sort of use? If not, don't allow publication. Will the publisher be responsible for obtaining written permissions to use this material from the individuals involved? If you have no permissions and the publisher won't make a good faith effort to obtain it, don't provide copies for use for publication or distribution without talking to your lawyer.
- Libel and Slander:** Does the file contain willfully misleading, damaging, or false information about an individual, group, firm, or organization? Will the publisher or vendor obtain permission to use this material from the individual or corporation that may have been libeled or slandered? If not, talk to the solicitor. *Note:* Libel refers to written falsehoods; slander refers to spoken falsehoods.
- Restrictions and the Freedom of Information Act (5 USC 552):** Does the publisher understand that federal employees must make federal holdings (including the digital copies) available to any individual who asks for them? All files, with a few exceptions, are available under a Freedom of Information Act request or a subpoena, and subject to the nine exemptions of the Act. We can't limit access to one publisher or researcher.

Figure 3.11. Digital Publication Project Checklist (Sample) [Optional] (continued)

2. Legal and Ethical Issues (cont.):

- American Indian Religious Freedom Act (42 USC 1996 and 1996a):** Does the file reproduce items or places that are sacred, religious, or sensitive, such as burial materials, remains, or sacred landscapes? Will the publisher obtain permission to use any materials judged sensitive by NPS with the affiliated group(s)? If not, talk to the solicitor.
- Location of Caves and Wells (16 USC 4301-4310 and 5 USC 552):** Does the file indicate the physical location of caves or wells? Do not provide this to non-authorized park personnel, such as researchers, without checking with solicitors and park managers. Will the publisher ensure all specific location information is excluded in electronic versions of the documents to be used for access? If not, talk to the solicitor.
- National Historic Preservation Act Amendments of 1980 (16 USC 470w-3):** Does the file provide information on historic resources that might be damaged if the information is disclosed? For example, would disclosure cause a significant invasion of privacy? Will disclosure impede the use of a traditional religious site by practitioners? Will disclosure risk harm to a historic resource? If so, in consultation with the NPS solicitor, you may withhold information on the nature and location of historic properties, and owners' names and addresses.
- Archeological Sites (16 USC 469-469c and 16 USC 470 aa):** Does the file indicate the location or universal transverse mercator (UTM) of archeological sites including underwater wrecks? Don't provide location information to non-authorized personnel without checking with archeologists and solicitors. Will the publisher ensure all specific location information is excluded in all electronic versions of the documents intended for access?
- Classified Information (5 USC 552):** Does the file reproduce any classified military or intelligence information? If so, don't provide it to a vendor until it has been declassified. Ensure all documents provided are free from such classifications, even if they are old.
- Publicity Rights (State Laws):** Does the file reproduce the name, image, words, or persona of a famous individual (living *or* dead), which may be protected under state publicity legislation? Will the publisher obtain permission to use these names or images from the holder of the publicity rights or their heirs?
- Image Manipulation and Moral Rights:** Does the project plan on manipulating the work of an artist? Will the project publish an artist's work without a credit line?
- Authorized Negotiator:** Have you identified who in your organization is authorized to accept or deny the offers of digital publishers and order fulfillment services? Is a procedure in place for considering such offers to guide the park negotiator?
- Cost Recovery:** Will the park receive cost recovery fees? How is the money collected, accounted for, and received by the NPS? What account is authorized to receive the funds? How will the money be used?
- Exclusive Rights:** Don't grant exclusive rights to use, publish, distribute, exhibit, perform, prepare derivative works from, sell, or reproduce NPS cultural or natural resources including materials under copyright protection or in the public domain. According to the Freedom of Information Act, if one organization has access, others may also.

Figure 3.11. Digital Publication Project Checklist (Sample) [Optional] (continued)

3. Content and Context Use Issues of Digital Images and Products

- Number of Uses:** Determine if the publisher is asking for one-time interior use of an image (exterior would be the CD-ROM box or book cover, and must be negotiated and agreed to in writing) in one format in one edition (one language and one publisher). If the publisher is asking for multiple edition use, multiple title use, or all digital rights, move the discussion to one-time use. Supplemental editions must be authorized and paid for separately.
- Credit Line:** Require the vendor to always include the full park credit line as supplied, such as "Courtesy of National Park Service, (Park Name), (Collection Name) (Collection Catalog Number), (if possible also include, Box number, Folder number, and Image number.)" The text may require a provenance line that incorporates the creator (photographer or author's name, media/format, date, title, subject, and size).
- Captions Source:** Determine if you will be responsible for providing the caption or if the caption will be assembled by the digital publisher and reviewed by the park before publication. If you won't have the opportunity to review the captions, insist the captions be published as provided by you. Or include a clause that states . . . "the digital contractor may edit or change the caption as long as the caption information published does not delete correct information or provide erroneous descriptions or information about the elements."
- Context Control:** Find out if you will have final approval of the context (product, text, captions, layout, and informational context or position in the text) of the digital image for approval purposes, or if you will only have the right to correct factual inaccuracies.
- Retaining the Image on a Database:** Once the agreement has lapsed, the publisher or author is informed that he must erase the image from his database.
- Contracts Revoked:** If the planned product based on the museum's digital files gets published, all rights revert to the NPS, and all digital files must be erased by the publisher or author.
- Security:** Will the publication be sufficiently secure to prevent:
 - unauthorized downloading
 - transferring
 - copying
 - manipulation of content

Are specialized technologies (watermarks, encryption codes, or digital thumbprints) used to protect digital images? Ensure file names and icons do not appear in windows or on the desktop. Don't authorize distribution via floppy discs or other insecure formats.

- Reproductions Appearance:** Digital image files must be made from color-corrected transparencies or curatorially and editorially approved black-and-white photographs provided by the NPS. Black-and-white conversions from color transparencies are not permitted, nor are reproductions from printed images, 35mm slides, or photographic materials obtained outside of the NPS or created for other purposes, such as park brochures.

Figure 3.11. Digital Publication Project Checklist (Sample) [Optional] (continued)

3. Content and Context Use Issues of Digital Images and Products (cont.):

- Reproduction Size:** Each reproduction must be shown in the electronic document in its entirety, within a framed border, so that the image *is not cropped by the edges of the monitor viewing screen*, regardless of the hardware or software used. Nothing may be superimposed on the reproductions, including lettering or another image. Credit lines must be near, or hypertext linked to, the images.
- Documentation:** All digital images, sound files, video files, and text files require a caption including a credit line, a provenance line (creator, media/format, date, title, size), and copyright notice that must appear as specified without editing, omissions, or use of acronyms. The caption must appear in the space surrounding the reproduction on the same monitor or screen.
- Special Uses:** Special permission is necessary if the digital reproduction appears as a frontispiece, chapter divider, additional Web page, box image, or non-editorial, decorative illustration; in such cases an additional fee is payable. For other than interior usage, such as covers or exterior, all requests to reproduce will be considered upon application. No special or multiple use may be made of these digital images without permission, including promotional trailer programs or advertisements.
- Repurposing:** No reuse of scanned NPS materials is allowed without further permission. All applications for repurposing of NPS materials must be made in writing.

4. Negotiating, Contracting, and Payment Issues:

- Third Party Agreements:** Third party agreements are not allowed without the written consent of the NPS. All applications for third party agreements must be made in writing.
- NPS Name, Arrowhead Logo, and Image:** The National Park Service name, the park name, or the National Park Service arrowhead cannot be used without written permission in the contract.
- Negotiator:** Is the individual identified who is authorized to negotiate with the publisher (for example, the cooperating association)? Does this person need support from a NPS or DOI solicitor or Association or National Park Foundation staff member?
- Project Information:** Determine if the publisher can provide the following:
 - the project title
 - project media of publication
 - alternative publication plans
 - publication or release date
 - language(s)
 - publisher, distributor, project manager(s) name(s)
 - editor and designers' names, addresses, e-mail, and phone and fax numbers
 - retail cost per product.
- Product Schedule:** Has the publisher provided a publication schedule or work plan that meets the park's needs? If not, request a detailed schedule of all shoots with an overview of participants and a daily location shoot list.

Figure 3.11. Digital Publication Project Checklist (Sample) [Optional] (continued)

4. Negotiating, Contracting, and Payment Issues: (continued)

- Contract:** Was the publisher's offer made in writing with all the details described here spelled out? Have the lawyer and the contracting department reviewed and approved it?
- Length of Contract:** Many firms will ask for 10- or 20-year contracts. Try for short-term contracts for single products. If the publisher is asking for multiple-edition use, multiple-title use, or all digital rights, move the discussion to one-time use. Supplemental editions must be negotiated, authorized, and paid for separately.
- Publication Report and Review:** Has the publisher agreed to provide a written report at the end of the project indicating the NPS materials used and how many times and where each item was used? If not, ask for this.
- Fees:** Will you charge fees to recover costs of security and support staff (such as park curators or historians) during the image production process? Have you determined how you will handle fees received? Try to ensure the money received from digital work goes either towards preserving the items digitized or towards funding equipment and software to use the digitized files for reference and outreach, thus limiting collection wear and tear.
- Royalties:** Include a statement in the contract that states, "the NPS assumes no responsibility for any royalties or fees claimed by the creator of the digitized work or on the creator's behalf."
- Indemnification:** Has the publisher or researcher agreed to indemnify, defend, save, and hold the NPS harmless from any and all claims, demands, losses, or damages (including reasonable attorney's fees and expenses) arising out of or in connection with, any claim by a third party that results in a bona fide settlement, claim, or adjustment, and which, if proved true, would constitute a breach of the representations and warranties set forth above? If not, have this language added to the contract to protect the park.
- Copyrights:** The publisher is responsible for obtaining permission from the holders of the original copyright for all NPS items. The NPS is not necessarily the copyright holder. Get the publisher to sign a statement to this effect. Determine if the publisher is planning to copyright their digital file of your cultural resources. If so, ensure the vendor knows that other individuals will be producing digital files from the same items. The publisher may hold the copyrights to the completed work, such as a CD-ROM, while the NPS and others continue to hold copyrights for individual items reproduced therein. Determine what rights the NPS has to cite, publicize, or otherwise use the final product in education, Web work, and other endeavors. NPS should have permission to use the CD for non-profit purposes.
- Courtesy Copies:** The publisher is to provide four copies of the finished piece for your collections. At the NPS, one copy goes to the park's museum collection, another to the park's library, the third goes to the National Center Library of the appropriate program, and the fourth to the Harpers Ferry Center Library.

Figure 3.11. Digital Publication Project Checklist (Sample) [Optional] (continued)

4. Negotiating, Contracting, and Payment Issues (cont.):

- In-Kind Donations:** Discover whether the park will receive:
 - gifts of the finished product
 - discounts on products
 - discounts on digitizing services
 - donations of the rights to use products or digital images
 - donations of software and hardware
 - financial donations towards the preservation of the original item
 - financial donations to fund historical, archival, or curatorial fellowship in the park to aid future digitization
 - gifts of the right to use high-resolution, large preservation files of the image without restrictions in NPS products, including the World Wide Web

Check the NPS donor recognition guidelines from the Policy Office for more guidance.

Figure 3.11. Digital Publication Project Checklist (Sample), [Optional] (continued)

Memorandum of Agreement
between
NATIONAL PARK SERVICE
and
Z CORPORATION

This agreement, entered into on _____ (year), between Z Corporation (**Z**) and the United States of America, acting by and through the National Park Service (NPS), A National Park (**A**).

ARTICLE I. Background and Objectives

Whereas, 16 U.S.C. Section 6 authorizes the NPS to agree to accept donations of money for the purposes of the National Park System; and

Whereas, 16 U.S.C. Section 18f(a) authorizes the NPS to accept donations and bequests of money or other personal property, and administer them for museum purposes; and

Whereas, the NPS and A have the responsibility for protection of park resources through interpretation and education; and

Whereas, **Z** will produce a CD-ROM product on A's resources that will help A meet its educational responsibilities at no cost to A; and

Whereas, **Z** wishes to use the produced CD-ROM title to demonstrate the capabilities of its software package, M, in delivering multimedia information; and

Whereas, the parties hereto intend to define the terms and conditions under which the project is to be performed; and,

Now Therefore, the parties agree:

ARTICLE II. Statement of Work

A. A Agrees to:

1. [Define objectives of the CD-ROM project.]
2. Provide access to museum for photographing, copying, digitizing of agreed upon museum collection items.

10.

11. *Figure 3.12. Memorandum of Agreement (Sample) [Optional]*

3. Provide guidance on what items in the collection will best illustrate agreed-upon story lines.
4. Provide names and phone numbers of subject matter experts for **Z** to contact.
5. Provide periodic review of the project.
6. Provide staff time up to and including 50 hours to accomplish the above.
 - a. Submit costs incurred by **A** on this project to **Z** monthly.
7. Allow the use of the CD-ROM to demonstrate **Z**'s software in delivering multimedia information.
 - a. Such allowance does not include using **A**'s name as an endorser or promoter of the software. **A** and the NPS do not endorse products.

B. Z agrees to:

1. Compensate **A** for all development, design and resulting costs of the proposed CD-ROM including but not limited to:
 - a. All materials, travel and staff time related to the project, calculated to be \$_____.
 - b. All materials, travel and staff time related to the project whether or not the project is completed.
2. Provide copies to **A** of all digitized materials, videos, photographs, audio tapes produced, including out-takes and other materials not used (specify size in pixels) and specify format such as CD-ROM or tape cartridge.
 - a. These materials will be the highest quality possible including high resolution for the digitized materials (indicate size desired here).
3. Provide to **A** a state of the art IBM compatible computer system to allow visitors to use the CD-ROMs at **A**.
4. Provide to **A** 1000 CD-ROMs, Macintosh compatible on _____(date).
5. Provide to **A** 1500 CD-ROMs, IBM compatible on _____(date).
6. Provide to **A** a copy of **Z**'s software developed for this project.

C. It is mutually agreed that:

1. **A** has final approval of all elements of the CD-ROM package.

Figure 3.12. Memorandum of Agreement (Sample) [Optional] (continued)

2. Parties will meet periodically to define timelines, review points, and decision junctures.
3. No alteration or variation of the terms of this Agreement shall be valid unless made in writing and signed by the parties hereto, and no oral understanding or agreement not incorporated herein shall be binding on any of the parties hereto.
4. Z will indemnify A from all lawsuits including court costs and legal fees, resulting from this CD-ROM or its advertising, sale or distribution including copyright settlements, privacy settlements, and publicity settlements.

ARTICLE III. Term of Agreement

The terms of this Agreement shall be from the execution of this Agreement to _____(date). This Agreement may be renewed upon mutual written agreement between both parties.

ARTICLE IV. Key Officials

Park:
 Superintendent:
 Name/Signature
 Address
 City, State Zip Code Telephone Number
 Z Corporation:
 Responsible Official:
 Address
 City, State Zip Code Telephone Number

ARTICLE V. Payment

Z will reimburse A for actual staff costs which are \$_____.

ARTICLE VI. Property Management and Disposition

- A. All materials produced by this project become the property of A.
1. CD-ROM masters will be turned over to A, including hardware and software to produce more.
 2. IBM compatible computer system will be entered onto A property lists.

ARTICLE VII. Standard Clauses

During performance of the Agreement, the participants agree to abide by the terms of the Executive Order 11246 on non-discrimination and will not discriminate against any person because of race, color, religion, sex, or national origin. The participants will take affirmative action to ensure that applicants

Figure 3.12. Memorandum of Agreement (Sample) [Optional] (continued)

are employed without regard to race, sex, color, creed, age, marital status, national origin, sexual orientation, non-disqualifying handicap conditions, or any other non-merit factors.

No member or delegate to Congress, or resident commissioner, shall be admitted to any share or part of this Agreement, or benefit that may arise therefrom, but this provision shall not be construed to extend to the Agreement if made with a corporation for its general benefit.

Z shall not publicize, or otherwise circulate, promotional material (such as advertisements, sales brochures, press releases, speeches, still and motion pictures, articles, manuscripts or other publications) which states or implies Governmental, Departmental, bureau, or Government employee endorsement of a product, service, or position. No release of information relating to this Agreement may state or imply that the Government approves of the Z's work product, or considers Z's work product to be superior to other products or services.

Z must obtain prior Government approval from the Superintendent of A for any public information releases which refer to the Department of the Interior, any bureau, park unit, or employee (by name or title), or this Agreement. The specific text, layout, photographs, etc., of the proposed release must be submitted with the request for approval.

ARTICLE VIII. Termination

This Agreement shall terminate upon completion of the project or on ____ (date), unless terminated or renewed by mutual agreement.

This Agreement may be terminated by either party, prior to the completion of the project, upon thirty (30) calendar days written notice to the other party with the reasons for termination stated in the notice.

SIGNATURES

For Z Corporation:

Date: _____
Responsible Official Name/Signature

For the National Park Service, A:

Date: _____
Superintendent Name/Signature

Figure 3.12. Memorandum of Agreement (Sample) [Optional] (continued)

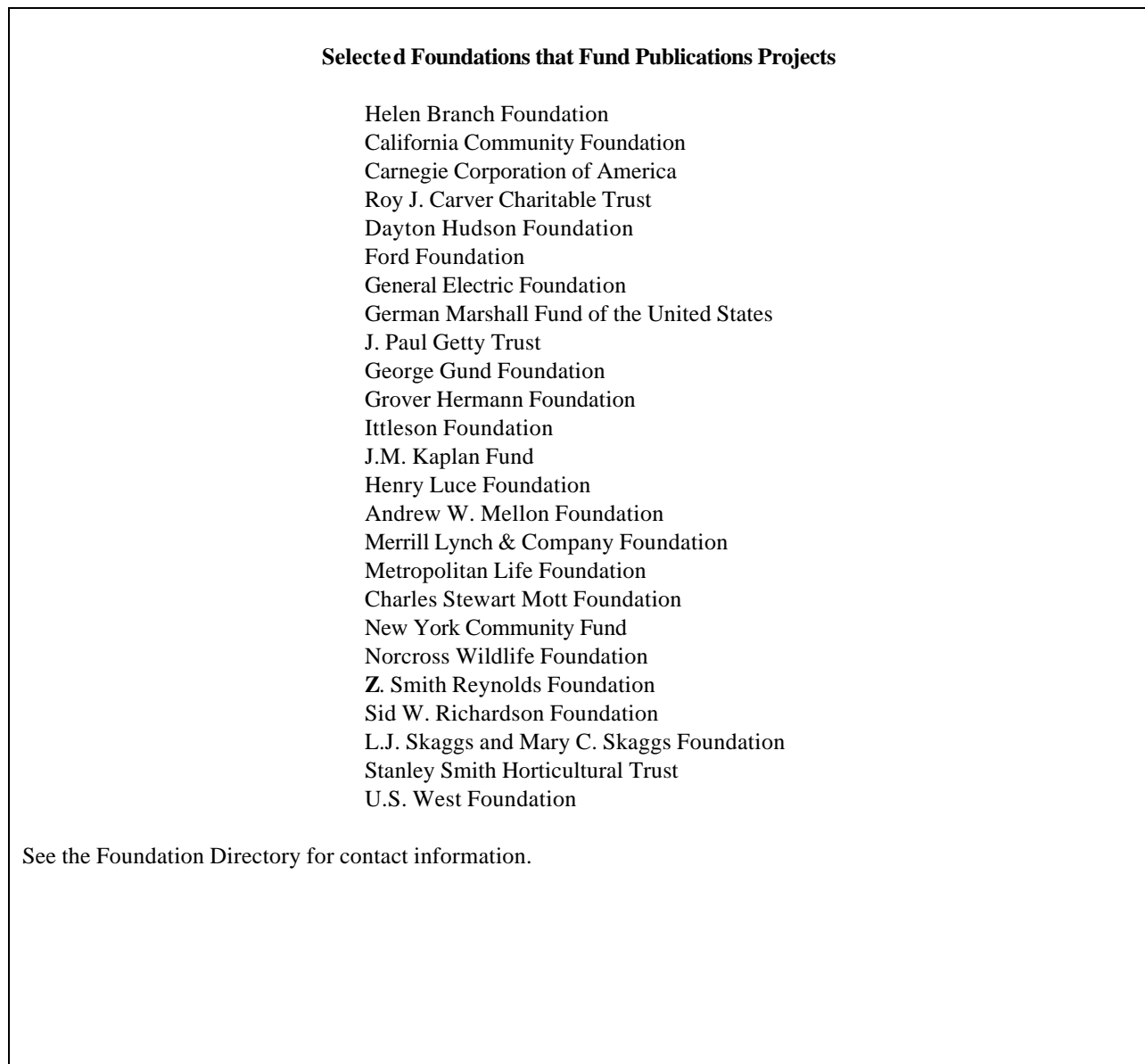

Figure 3.13. Selected Foundations that Fund Publications

Chapter 4: Two-Dimensional Reproductions

	<u>Page</u>
A. Overview	4:1
What information will I find in this chapter?	4:1
What NPS policies and guidelines do I need to know?	4:1
What are 2-D reproductions?	4:2
What are masters?	4:3
What is the difference between copies, derivatives, duplicates, facsimiles, and surrogates?	4:3
What other basic concepts must I understand?	4:5
When and why would I want 2-D reproductions?	4:7
How do I know what process and format to select for what purpose?	4:8
What reproduction services should my park provide to researchers and park staff?.....	4:8
What do I need to know before I begin planning my park's 2-D reproductions standard operating procedure?.....	4:9
How do I handle commercial requests to film or photograph park collections?	4:13
What sources of additional guidance should I consult?	4:17
B. Preliminary Policy and Planning Considerations	4:17
What are the various kinds of 2-D reproductions?	4:17
Who wants these 2-D reproductions?	4:18
What materials are most frequently reproduced?	4:19
Why should I produce 2-D reproductions?	4:20
How do I set up my park's 2-D reproduction fee schedule?	4:21
Do I have to make all types of 2-D reproductions available.....	4:22
How do I produce these 2-D reproductions?	4:23
How should I select and work with a cooperating association or reprographic contractor?	4:23
How do I maintain control when working with a contractor or cooperating association to produce 2-D reproductions for special projects?.....	4:25
How do I maintain control during digital projects?	4:28
How do I maintain control during microfilming projects?	4:28
How do I maintain control for motion picture film and photography projects?	4:29
How do I maintain control over collections for audiotaping and videotaping projects?.....	4:30
How do I maintain control for printed and xerographic reproduction projects?	4:30
How should I operate if I choose to do the work in-house?	4:31
How do I keep control of my content when producing 2-D reproductions in-house?	4:31
Is approval necessary before 2-D reproductions are made?.....	4:33
How do I handle requests for photographs of original archival and museum materials?	4:33
What items require examination and/or stabilization before being copied?	4:34
Should I allow researchers to make private 2-D copies of museum objects with personal equipment?	4:37
What notice should I place on all copies?	4:38
C. 2-D Reproductions Management Implementation Issues	4:39
What management issues apply to all kinds of 2-D reproductions?.....	4:39
What 2-D reproduction procedures should I set up for my park?.....	4:40
What is the standard operating procedure for obtaining 2-D reproductions?	4:42
What work don't I have to do for researchers?.....	4:47
What information must the researcher supply on a Researcher Duplication Request Form?	4:48
How and why do I determine if a usage is for-profit or not-for-profit?.....	4:49
How do I handle a permission to publish request?	4:50
How do I judge whether a usage is appropriate or not?	4:50
How do I decide whether to approve a researcher duplication or publication request?	4:51
When might I refuse to grant permission to publish?	4:54

Must researchers fill out NPS Special Use Permits to publish a NPS image?	4:54
What are the appropriate caption and credit line policies?	4:54
Can I charge money for permission to publish a NPS item?	4:55
How do I handle cost-recovery money received from duplication work?	4:55
What special needs might the researcher indicate?	4:56
How do I identify the impacts on the collection?	4:56
What steps do I take to prevent collections from being damaged?	4:57
How do I inspect copies once they have been returned?	4:57
D. Glossary	4:58
E. Selected Bibliography	4:63
F. List of Figures	4:68

CHAPTER 4: TWO-DIMENSIONAL REPRODUCTIONS

A. Overview

1. *What information will I find in this chapter?*

This chapter contains summary information on a broad range of issues relating to the production of two-dimensional (2-D) copies of archival and museum objects. This chapter outlines the basic steps necessary to make digital, microfilm, motion picture film, photographic, sound recording, videotape, or xerographic copies of archival collections and images of museum objects for exhibition, research, sale, and use in publications.

This chapter doesn't cover the production of three-dimensional (3-D) reproductions of 3-D items; although it does discuss the creation of 2-D images (photographs and digital images) of 3-D objects. For information on 3-D reproductions, see Chapter 5: Three-Dimensional Reproductions. Also see *Museum Handbook*, Part II (MH-II), Appendix L: Photography, and *Museum Handbook*, Part I (MH-I), Appendix R: Curatorial Care of Photographic Collections.

2. *What NPS policies and guidelines do I need to know?*

You should become familiar with the sections related to managing museum collections in the federal law and NPS policies and guidelines listed in Chapter 1: Evaluating and Documenting Collections Use, Section C.3, Chapter 2: Legal Issues, and the guidelines listed below:

- 43 USC 1460 (Copies of records, documents, etc.; charges; disposition of receipts):

The Secretary of the Interior, or any of the officers of that Department may, when not prejudicial to the interests of the Government, furnish authenticated or unauthenticated copies of any official books, records, papers, documents, maps, plats, or diagrams within his custody, and may charge therefore a sum equal to the cost of production thereof, plus the cost of administrative services involved in handling the records for such purposes....

- PL 106-206 (Commercial filming activities on federal land-106th Congress, Second Session, May 2000):

...establish[es] a fee [and permit system] for commercial filming activities on Federal land....such fee shall...be based upon the following criteria: 1) The number of days the filming activity or similar project takes place...2) the size of the film crew present...3) the amount and type of equipment present [and]...other factors...the Secretary shall not require a permit nor assess a fee for still photography...if such photography takes place where members of the public are generally allowed. The Secretary may require a permit, fee, or both, if such photography takes place at other locations where members of the public are generally not allowed, or where additional administration costs are likely. The Secretary shall require...a reasonable fee for still photography that uses models or props....

Note: No filming or photography is allowed if it causes a likelihood of resource damage, unreasonably disrupts the public's use and enjoyment of the site, or poses health and safety risks to the public.

- Director's Order #32: Cooperating Associations
- Director's Order #21: Donations and Fundraising
- NPS Cooperative Agreement Authority (February 2, 1998)
- Omnibus Consolidated Appropriations Act of 1997, Public Law 104e-208 (September 30, 1996), Title 1, National Park Service Administrative Provisions allow the NPS to:

...enter into cooperative agreements...that...transfer NPS appropriated funds to...State, local and tribal governments, other public entities, educational institutions, and private, nonprofit organizations for the public purpose of carrying out NPS programs...

3. What are 2-D reproductions?

2-D reproductions are flat, copy images of original works that are exact copies of the contents of the originals, although the size and process of the copy may be quite different. The original works may be:

- 2-D items such as documents, drawings and plans, graphic prints, magnetic tape, and photographs
- 3-D objects such as biological and/or paleontological specimens and archeological, ethnographic, and historical objects (including fine arts objects)

While direct imaging from museum objects is simply called photography or digital imaging, the generic process of creating copies is called **reprographics**. The related term **reformatting** implies any or all of the following actions:

- producing a later generation copy image from either an original item or a copy
- starting with an original or copy in one format, such as a photographic original, and using it to produce a second generation copy in another format, such as microfilm or digital files
- beginning with original content, such as a TIFF file, then changing either file format (for example, to JPEG or GIF) or laying out the textual or visual format on the page in a new way so that all the original elements are there, but the copy is now visually different (for example, the original text or image may be vertical, while the copy text or image is horizontal)
Note: See the glossary at the end of this chapter for definitions of TIFF, JPEG, and GIF.

This chapter describes these seven key reproduction formats:

- digital files
- microfilm

- motion picture film
- photographic reproductions
- sound recordings
- videotapes
- xerographic copies

4. *What are masters?*

Masters are the original or first generation images.

- **Digital files:** The digital master file (first digital copy) is usually a large file that hasn't been compressed (shrunk by removing non-essential information for ease of storage). Some digital file formats are proprietary or owned by a software firm. Firms may change formats frequently to keep up with software changes, making older files impossible or difficult to use on new software. Digital masters shouldn't be in proprietary formats, but instead should be in generic formats such as uncompressed TIFF for ease of future use.
- **Photos and microfilm:** The original negative, print, slide, and/or transparency made by the original photographer are all considered the first generation or master images for photographs and microfilm. The copies are all 2-D reproductions and second or later generation copies made from the originals. According to photographic terminology, a duplication master negative or preservation master transparency is not a copy, because it is a first generation image.
- **Xerographic copies** (also known as electrostatic copies or photocopies): The xerographic master is used for other copying and is considered the first generation.

5. *What are the differences between copies, derivatives, duplicates, facsimiles, and surrogates?*

Generally speaking, 2-D reproductions are one of the following:

- **Copies** are non-original (second generation or later) reproductions made from first generation or master negatives, digital files, or other source documents. Copies include copy prints made from master negatives, derivative files made from master digital files, and microfilm distribution copies made from master microfilm negatives. Second generation or later prints of record photographs or photographic negatives or prints made from original negatives or prints may also be called copies. Copies are often known by their method of creation, such as carbon copy.
- **Derivatives** are digital (electronic) files made from other digital files often in a different size or for a special purpose. These digital derivatives may be thumbnails (very small files) or derivatives made for special usages, such as on the Web. Derivatives are sometimes referred to as digital surrogates.
- **Duplicates** are two identical versions of the same generation. The original creator of the item may create two identical originals at the same time on the same equipment using the same materials. For example: the same photographer may take two identical images of the same subject

matter on the same roll of film using the same camera at the same time and place. While the two images are snapped only seconds apart and appear identical, they have different frame numbers and purposes and are said to be duplicates of each other. The first photograph is the preservation master, the second the usage copy. In this example, both images are originals as they are both first generation and identical to each other for most practical purposes. A duplicate is the only “copy” process that may be first generation. If the duplicates are letters, they should both have original signatures. **Note:** Most people now use the word “duplicate” interchangeably with the word “copy.”

- **Facsimiles** are copies of the content of an item usually made as close to identical as possible to the original often using the same media, process, appearance, and often the same format as the original. Facsimiles are almost always produced later by someone other than the creator of the original. When the word “facsimile” is preceded by a process name, such as “photographic facsimile,” you are being notified that the facsimile is NOT in the same process or format as the original. Therefore the facsimile *is* a close-to-identical copy in that process or format.
- **Surrogates** are copies, most frequently digital files, made from an original object as the result of digital capture, digital photograph, or digital imaging that take the place of an original for a specific purpose, such as preservation, deposit at another institution, or for other purposes noted under Section A.2 above.

The copyright law authorizes the production of a preservation surrogate of original works held by a museum, even when the museum doesn't have the copyright to the work. See Chapter 2: Legal Issues, Section C.13

The word “surrogate” is widely used when referring to copies produced in digital format to alert readers that the original has been reformatted to produce the copy. The difference between a surrogate and a derivative is that the derivative is always made from another digital file, while a surrogate may be an original digital image of an object. The process of making a digital image of an original object may be called digital capture, digital photography, or digital imaging.

In some reprographic processes, such as photography, microfilm, and motion picture film, each generation of copy after the first has less information. This information loss between generations is due to a loss of resolution inherent in lens and film-based imaging systems. To ensure that the park maintains the more complete and valuable original, all copies should be labeled as “copy” to ensure that they don't become confused with originals.

It is also wise to stamp, scan, or post a copyright warning statement on all xerographic and digital duplicates to ensure that researchers realize that the copies provided are being made available for research purposes, not publication. Further information on labeling and watermarking can be found in Section A.9. See also Chapter 3: Publications, for further guidance.

6. *What other basic concepts must I understand?*

The most basic concept is that of generations of reproductions, which are organized like family lineages. The original or first generation item is often called the preservation master (or simply the master). The second and later generation images are copies and may also function as facsimiles or surrogates.

- ***For digital files***, the original (first generation) large, non-proprietary and uncompressed parent file is often called the master file. Non-proprietary file formats are free and generic, as software companies do not own them. Later files, which can be in thumbnail (very small), compressed, proprietary, or any other useful format, are called derivatives or usage files (the copies or child files). Digital cameras can be used to produce original images as well as copies. Scanning from original materials, sometimes called “direct digital capture” refers to:
 - *original or first generation images* made in a digital camera
 - *copy files* made from originals
 - “*lossless*” *compressed digital files* (such as TIFF files) don’t lose information from generation-to-generation. Lossless compression, however, compresses files to 1/2 to 1/3 their original size, while lossy compression, described below, shrinks files to 1/10 their original size.
 - “*lossy compression*” *file formats* (such as GIF or JPEG) ensure that the image will look different when decompressed than it did before compression. These differences between the original and the copy result in odd visual phenomena in the copy. These effects may be like looking through a piece of bubble glass or a prism and are known as “compression artifacts” or “unintended visual effects.” For lossy compression, the amount of information in compressed files is less than that in the original uncompressed files. “Lossy” digital file compression works by discarding information that is not easy to view, thus ensuring that the copy file is different from the original.

For more information see *Conserve O Gram (COG) 19/9*, Planning Digital Projects for Access and Preservation, and the Appendix A: Publications Glossary.

- ***For microfilm***, the first camera-produced microfilm negative is usually a silver halide negative called the master (the parent image) and is said to be first generation or original. The subsequent or second generation negative and positives made from this master are called copies (child images). There are several copy processes, including diazo, silver halide, vesicular, and color processes. There are also many formats of microfilm including aperture cards, card jackets, and roll film in several film gauges (sizes) such as 16mm and 35mm.

In some cases copies may be produced in the longer-lived silver halide roll film format for deposit in another archives, library, or museum.

Note: Each generation away from the original negatives results in a decrease in the amount of information in the copy.

- ***For motion picture film***, the first camera-produced negative is the true original (the parent image), although the first generation film transparency and many outtakes (film footage cut from the original film) can also be considered originals. Later edited generations, such as the commercial films viewed in theaters, are often many generations removed from the original or first generation film. **Note:** Edited films are rarely first generation, but may be duplication masters (second generation) or usage masters (third generation) or viewing copies (anything from the third generation on). Each generation removed from the original negative has less information than the one before it.
- ***For photographs***, the first camera-produced negative and first print or transparency are called originals (the parent images) and are said to be of the first generation. Images made from first generation originals are called copies or second generation images (the child images). Copies can be produced from the negative, the positive, or the transparency, depending upon the type of reproduction process employed (direct duplicate, interpositive, or copy negative). **Note:** Each generation removed from the original negative and print has less information than the one before it. Photography can be used either for copy work or to produce original works.
- ***For sound recordings***, the material originally recorded upon, whether a wax cylinder, wire recording, or reel-to-reel or cassette tape, is considered the original, first generation material. Copies made from the originals on phonograph discs, reel-to-reel tape, or tape cassettes are called copies or second generation recordings (child recordings). **Note:** Unlike photographs, each duplicate of an original magnetic recording can be as good as the original unless improperly recorded. If improperly recorded, information can be lost. For further information see Chapter 3: Publications, Section I, Sound Recordings.

It is possible to sound engineer recordings, thus significantly reducing background noise. Background noise may provide information, such as the circumstances and ambience of the original recording effort. So, while second and later generation magnetic copies may be identical to the original if unaltered and copied well, they are not necessarily identical as they may have been edited or copied poorly. Editing and sound engineering alter a recording's characteristics and informational content.

- ***For videotapes***, the first recording, whether two-inch reel-to-reel tape in Beta format or tape cassettes in VHS format, is the original or first generation material (parent recording). Copies made from the originals on reel-to-reel tape or tape cassettes or cartridges are called copies or second generation recordings (child recordings).

Unlike photographs, each duplicate of an original magnetic recording is identical to the original, as there is no generational loss when copying. However, it is possible to edit recordings, cutting portions of the tape, sound engineering the audio content, and effectively revising the original recording. Magnetic copies may have been edited or sound engineered, thus altering their characteristics and their informational content.

- ***In xerographic files (photocopies)***, the original document is the parent, while the first high quality copy (second generation or child image) becomes a duplication master, used to produce additional copies (third generation or grandchild image) for reference and research purposes. **Note:** Xerographic copies can be almost as good as original printed text or line art, although they rarely capture the nuances of continuous tone photographs and may not amply capture all handwriting. Information is lost with each successive copy generation.

7. *When and why would I want 2-D reproductions?*

You produce 2-D reproductions because you, your park staff, researchers, and scholars will need them regularly. Most parks already produce 2-D reproductions for education, exhibitions, interpretation, publications, public service, and a host of similar functions, including:

- ***condition photographs*** to document in detail changes, damage, defects, or flaws in an item for insurance, loans, and similar purposes
- ***deposit copies*** created for placement at another repository to facilitate research
- ***duplication masters*** to be used when making further copies
- ***evidential copies*** created as legal evidence for courts and certified by the copy agency to be a true and complete copy of the original
- ***exhibition copies*** for use in an exhibit or display to replace the original item, either in a museum exhibit or as an exhibit on the World Wide Web
- ***fair use copies***, as defined by copyright laws, made for non-profit use in education, scholarly research, news reporting, commentaries, and parodies as long as the use doesn't affect the market for the work. Scholars often request copies for research instead of taking notes. Researchers don't need written permission from the holder of the copyright before using the materials for this purpose. See Chapter 1: Evaluating and Documenting Museum Collections Use, and Chapter 2: Legal Issues, for more guidance.
- ***presentation copies*** used in films, slide shows, and videotaped presentations or for award purposes
- ***preservation copies*** created as non-profit preservation facsimiles of the original, which may be deteriorated
- ***publication copies*** for use in an article, book, brochure, exhibit catalog, finding aid, motion picture film, pamphlet, videotape, Website or other publication
- ***record copies*** to document what has been published or reproduced to help with future planning and tracking activities
- ***research photographs*** for educational, interpretive, scholarly, and student work (See "fair use copies" above.)

- **sales copies** created at the request of an individual or organization for use in a for-profit publication, such as a book or videotape, or for use in a derivative work, such as a tee shirt, calendar, or similar product, or as a facsimile for sale
- **security copies** created to serve as back-up copies in case of theft or destruction of the original or to take the place of the original in a high risk situation, such as a traveling exhibition
- **treatment photographs** to document the before and after states of objects undergoing conservation treatment
- **use copies** to save the original item from handling damage
- **commercially produced copies** created by for-profit organizations for their own use when approved by the NPS (See Section B.9.)

Archival and museum professional standards support the need for archives and museums to provide 2-D reproductions of collections as a basic service to the community of scholars and staff.

The *Statement on the Reproduction of Manuscripts and Archives for Reference* by the Society of American Archivists states:

It is the responsibility of a library, archives, or manuscript repository to assist researchers by making or having made reproductions of any material in its possession, for research purposes, subject to certain conditions. Manuscript and archival materials may be reproduced if:

- (a) *The conditions of the originals will permit such reproductions*
- (b) *The originals have no gift, purchase, or legal restrictions on reproduction.*

8. *How do I know what process and format to select for what purpose?* See Figure 4.1 to identify what process or format of reproduction you should use for each of the purposes listed in Section A.6 above
9. *What reproduction services should my park provide to researchers and park staff?* Your park can provide basic services internally on a cost-recovery charge-back basis or you can have the work done by a contractor or cooperating association who will follow NPS policies and procedures. The essential elements of your programs include:
 - **Documentation services:** Be able to provide researchers with captions and credit lines promptly upon request. (**Note:** The park charges back the cost of these services to the researcher in accordance with 43 USC 1460.)
 - **High quality publication images:** Have the capability to provide inexpensive but high-quality images for publications or exhibitions in a timely fashion. (**Note:** Again, this work must be done by professionals, not researchers or untrained staff. See Sections B.9-10 for reasons. Copies are charged back to the researcher on a full cost-recovery basis as per 43 USC 1460.)
 - **Image search capability:** Be able to search images at the item-level quickly by subject, name, creator, process, format, and era. (**Note:** In

most parks whether or not you can search at the item-level depends upon whether or not the items were well cataloged into ANCS+. For many archival items, the actual item-level cataloging will not take place until the item is requested for duplication as most archives are not item-level cataloged, and the cost may be charged back to the researcher for the work.)

- **Rights and permissions help:** Have the ability to obtain quickly intellectual property rights (particularly copyrights) and permission to publish, exhibit, and use for other purposes. See *MH-III*, Chapter 2: Legal Issues, for guidance.

Park staff should help researchers by informing them of the rights that the park can authorize. When the researcher's proposed use is appropriate and the requested work is in the public domain or the park has the rights, the park staff should offer to authorize appropriate publications.

NPS staff should never undertake rights research work (locating copyright holders) or attempt to obtain permissions or licenses for requesters. Park staff should never grant permission to publish materials for which the NPS doesn't have the rights, including copyrights, and privacy and publicity rights. In these cases, restrict access to privacy-related materials, don't allow copying of publicity related materials, and provide copies of copyrighted materials for fair use purposes only. See Chapter 2: Legal Issues, for guidance.

Insist that the researcher complete the copyright/privacy statement, the researcher registration form, and the researcher duplication form. (See *MH-II*, Appendix D, for forms.) When a researcher or publisher asks the NPS to authorize publications and the park staff wish to comply, park staff will send out the NPS permission letters to the researcher or publisher, rather than signing researcher or publisher's permission forms. See Figure 4.6, Permission to Publish Letter.

- **Speedy production of low-resolution research images:** Be able to provide low quality or low-resolution research images, such as xerographic copies, quickly and inexpensively. **Note:** While lower resolution digital files and xerographic copies can often serve this purpose, this work must be done by park staff trained in copy procedures, materials handling, and policy and legal issues, not by researchers or untrained staff. Again, the full cost of the work will be charged back to the researcher.

10. *What do I need to know before I plan my park's 2-D reproductions standard operating procedure?*

Work with other park staff to develop a park reproduction procedure. If possible, include in your procedure development team any or all of the following people: your park or regional archivist, cultural resources manager, curator, Freedom of Information Act (FOIA) officer, historian, librarian, natural resources manager, public relations officer, and records manager. Also include at least one member of your administrative staff. See Chapter 1: Evaluating and Documenting Museum Collections Use, Chapter 2: Legal Issues, Chapter 6: Other Uses of Museum Collections, and Director's Order #53: Special Park Uses, Section 14, Filming and Photography.

The 2-D reproduction standard operating procedure should resolve the following issues:

- **Responsibilities and services:** Determine whether your park will provide each of the seven contemporary reformatting options (digital, microfilm, motion picture film, photographs, sound recordings, videotapes, and xerographic copies). Decide the following:
 - Will the work be done in-house using park staff or with cooperating associations or collaborators within or outside of the park?
 - Who will produce the copies, how, and to what standards?
 - Who will manage the visual collections (cataloging, preservation, and similar issues)?
 - Who will handle the correspondence, image location, labeling, captioning, intellectual property rights work, credit line production, financial transactions, copy inspection, and packing and shipping of the copies? These jobs may be assigned to several individuals.
 - How will the park handle requests for rush orders, unusual formats, or special requests, such as requests from the NPS senior staff, reporters, and members of Congress?

Note: Fill requests within 20 days, unless there is a problem with obtaining copies from a remote location or a need to stabilize the original before it is copied. You may choose to give priority to certain types of requests in your policy, but you must respond to FOIA requests within 20 days.

- **Cost-recovery payment:** Describe how your park will handle the recovery of costs, under the authority of 43 USC 1460, which allows that the

“Secretary of the Interior or any of the officers of that Department, may...furnish copies of any official books, records, papers, documents, maps, plats or diagrams within his custody and may charge therefore a sum equal to the cost of production thereof [of the copy], plus the cost of administrative services involved in handling the records for such purposes....”

The park cost-recovery policy should be specific:

- Will the park charge the researcher for the production of a negative or original photograph or equivalent work when no duplication master exists in the park?
- Will the park insist that any negatives or transparencies produced to facilitate production of a print remain in the park, regardless of who paid for it? **Note:** Doing so will help the park retain control of its collections.
- How will money received be handled, recorded, secured, and appropriately documented?

- Will the park accept cash payments, money orders, credit cards, and personal checks for cost-recovery purposes?
- How will bounced checks be handled? Will fees be charged? Will collection agencies be used? If so, how?
- Will the park demand either prepayment (or at least a deposit) when the order is placed? If so, how will additional unexpected costs be handled?
- Which account will receive the money? **Note:** The superintendent will make this decision.
- For what future purposes will the money be used?
- Who will control the disbursement of the money?
- How will the cost-recovery fee level be set? (**Note:** Base cost-recovery fees upon actual park costs, such as the salary level of the staff members answering requests? Our legislation requires that parks and centers charge the same charge-back costs for all researchers, whether profit or non-profit, colleagues or strangers.
- When will fees be waived or reduced?
- **Contractor, staff, volunteers, or cooperating association selection:**
Indicate how the group doing the reproduction work will be selected:
 - What specifications and standards must they meet?
 - What pilot or test projects must they undertake?
 - Will the park run a test comparison by duplicating the same images with several candidate contractors and then inspecting the results?
 - Will the park send photographic pilot project work to a testing laboratory?
 - What will be the park's procedures for ordering and filling copy requests?
 - Will the park define proper handling procedures for the laboratory?
 - Will the park inspect how the group handles the materials?
 - Will the park indicate how limited the brightness/duration of light exposure must be?
 - Will the park specify the types of equipment that may be used (such as no mechanical or automatic feed copy equipment)?
 - Will the park inspect the group's equipment and laboratory?

- Will the park dictate how materials will be stored while at the duplication laboratory?
- Will the park require that the work be done in-house?
- Will the park set quality standards for 2-D reproductions? For example, will the park limit general requests for microfilm to the 16mm format silver halide; limit digital reproductions to 72 dots per inch (dpi); and offer only copy prints (not copy negatives)?
- How will shipment of materials to the researcher be handled?

Note: Regardless of who does the work, they must be trained in handling materials and be required to sign over to the park all copyrights to copies produced.

You may ship 2-D archival and manuscript materials for duplication purposes. Museum 3-D objects generally are not shipped out for record photographs unless already going out on loan, such as for conservation or exhibition. For archival and manuscript materials, ship duplication masters whenever possible. If shipping of original archival materials is necessary to make preservation, duplication, or usage copies, do so with caution to limit future preservation risks. Hand delivery is best. High priority materials for duplication include fragile or self-destructing items, particularly original cellulose nitrate, cellulose ester, and glass plate photographic collections. Stabilization may be necessary prior to reformatting.

- **Legal risk:** Decide what level of legal risk the park will accept:
 - Will the park insist on seeing the permissions from the intellectual property rights holders? *or*
 - Will the park simply require evidence of a good faith effort to obtain the permissions (such as a copyright search and letters to the last known address of the copyright holder)? *or*
 - Will the park provide the copy without authorizing publication and warn the researcher of his/her responsibility to obtain permissions? **Note:** See Figure 4.2 for a form that may be used for this purpose.
 - Will the park insist on use of the NPS digital watermark and the captions and credit line procedures listed in this chapter?
 - Will the park tell individuals making or obtaining copies that materials in the public domain (that is, materials that are no longer under copyright protection or that were created by the government) may not be copyrighted by another organization?
 - How will you ensure that the researcher is aware that he is legally responsible for observing intellectual property rights including copyright, privacy, publicity, and related legal issues?

- Will the park stamp, watermark, or mark all copies with a copyright notification statement? See Chapter 2: Legal Issues, Section C.12.
- Will the park notify the researcher that he/she must legally indemnify the NPS from any lawsuits resulting from his/her misuse of materials? See *MH-II*, Appendix D: Museum Archives and Manuscript Collections, Figures D.13a and D.14a for sample forms.
- **Restrictions:** Determine what rights the park will grant researchers:
 - May researchers digitize, photograph, videotape, film, microfilm, and resell 2-D copies of museum objects? In general this is NOT a good idea.
 - Will the park honor donor restrictions on duplication? If not, why not?
 - How will the park determine what materials are restricted and why? See Chapter 1: Evaluating and Documenting Museum Collections Use, and Chapter 2: Legal Issues, for guidance.

11. *How do I handle commercial requests to film or photograph park collections?*

PL 06-206 provides a mechanism for parks to collect fees from commercial organizations that are filming or photographing collections outside of public spaces or when commercial filming or photography poses additional administrative costs for the NPS.

For commercial filming: Before authorizing filming, you must determine if the filming will cause the collections damage, unreasonably disrupt collections use by the public, or pose a public health and safety threat. You must also ensure that the filming doesn't infringe copyright, privacy/publicity legislation, donor restrictions, or any restricted or sensitive data. If any of these situations are true, deny the filming.

If you authorize motion picture or video filming, the commercial organizations must complete a special use permit and pay a fee based upon the number of days of filming, the size of the film crew, and the amount and type of equipment present.

For commercial photography of collections: You may approve commercial still photography as long as it doesn't pose risks to the collections, doesn't affect the staff ability to serve the public, and doesn't pose health and safety risks. You will also want to ensure that no copyrights, privacy/publicity legislation, donor restrictions, sensitive or restricted data is copied. If the proposed photography poses any of these problems, deny the request. Generally large-scale duplication is a bad idea because it is very easy to miss a legal restriction or sensitive bit of protected data when many items are being copied at once.

Do not assess a fee or require a permit to film the exterior of the building or interior public spaces, but do so if the commercial firm wants to work in locations where the public is not allowed (museum storage or work spaces or exhibits after hours).

You may also charge a fee when additional administrative costs are likely, such as when staff must identify, locate, and handle objects for filming or still photography purposes. When extra work or non-public spaces are involved, you may require a fee and/or insist upon a permit. Fees collected go to the Recreation Fee Demonstration Program.

Don't allow outside researchers to make original 2-D copies of large quantities of NPS-held materials with their own cameras or scanners as it may infringe copyright, privacy, or publicity concerns; cause handling damage; cause light damage; strain relationships with affiliated groups if materials are later misused; or result in lawsuits. Park staff can't effectively control use of images made by researchers with their own equipment.

- **Maintaining control:** Decide how the park will maintain control over collections it manages. Decide how the park will warn researchers that they are not authorized to publish items that they obtained as research copies. Determine how the park will warn researchers that they aren't authorized to publish an item in a second edition or publication just because they obtained permission to use it in an earlier edition or publication.
 - When will the park refuse to provide copies? (damage to the resource; a negative impact on public accessibility; potential violation of copyright, privacy, publicity, or other statutory restrictions; preservation concerns; donor restrictions; and identified cultural sensitivities that may be protected by law)
 - Will the park decide that each use must be individually authorized by the park? (This is commonly done.)
 - Will the park refuse to grant long-term permissions to use material, such as “in perpetuity” or “all international rights in perpetuity?” (*Note:* Generally, it is best to grant limited, one-time use, or single-edition use for publications.)
 - How will the park prevent researchers, publishers, or others from using their own scanners, cameras, or other copy equipment to make copies of park collections?
 - How will the park implement the use of a watermark, hatch mark, or a clear plastic overlay sheet stating “Courtesy of _____ National Park. All rights reserved”? *Note:* NPS staff may use watermarks on all reproductions to indicate ownership and prevent misuse of images, with the potential exception FOIA requests that specifically state they want no watermark. FOIA requests for documents with no watermarks should be reviewed with the park FOIA officer on a case-by-case basis.
 - How will the park monitor the copying process to ensure proper handling of the originals and that proper captions and credit lines will always appear?

Note: It is essential to ensure that the copyrights, privacy rights, publicity rights, and similar legal, ethical, cultural, and donor-affiliated restrictions are not violated. Generally speaking this is easiest to manage if approvals are on a case-by-case basis, **hence copying using the researcher's own equipment and bulk copying pose particular risks to NPS collections and should be avoided.** If researchers (including park staff) are allowed to duplicate materials with their own equipment, have the researchers complete a duplication request form and copyright/privacy statement and indicate in writing with their signature, the purposes for which they may use the 2-D reproductions. See Figure 4.7, Wording to be Included in a 2-D Independent Contractor Agreement; Chapter 3: Publications; and Chapter 5, Figure 5.5, Cooperative Publishing Agreement.

- **Watermark:** A watermark is a visible or invisible encoding pattern (in an electronic file) or arrangement of paper fibers (in a non-magnetic paper document) that indicates the origins of the item (for digital files) or the material used in making the item (for paper documents). Not all digital watermarking packages work precisely the same. Some simply mark or produce a pattern on a document.

Others allow parks to search throughout the World Wide Web for all uses of NPS digitally watermarked items. Using these systems, researchers may click on the watermark to link directly to the NPS Web page that lists how to obtain permission to use the image and how to obtain higher quality copies. Thus the watermark can help NPS track use of digital files, as well as help non-NPS individuals learn more about how to obtain permissions and additional copies of NPS materials.

- Will the park require the use of a NPS or park watermark to indicate ownership by NPS or the park?
- Will the park insist that outside individuals creating files of NPS objects (if allowed), use a NPS digital watermark or other attribution mark so that the NPS can track use for appropriateness?
- **Digital copyright:** Decide the following:
 - How will the park protect from copyright conflicts those park images being digitized by non-contract organizations or individuals?
 - Will the park refuse to allow digitization if the digitizing firm plans to copyright the digital copy? If so, this policy should be applied consistently to all researchers.
 - Will the park refuse to allow cooperating associations to copyright digital copies of park-owned objects? **Note:** Recent case law (The Bridgeman Art Library vs. Corel Corporation in Federal District Court in New York, November 1998) indicates that mechanically produced reproductions of 2-D materials may not be copyrighted as they lack sufficient originality to qualify as an original work.
- **Management policy:** Determine how you will identify and deal with the management policy requirements that certain items in your collection be restricted and 2-D reproductions not be supplied. See Chapter 1: Evaluating and Documenting Museum Collections Use.

- **Extensive quotes and other non-fair uses:** Decide how requests for extensive 2-D reproductions, complete copies of a work, or direct quotations (beyond fair use), including images of textual documents, supplied as copies will be handled by the park. Develop a permission form and policy.

See Figure 4.6, Permission to Publish Letter, and Chapter 2: Legal Issues, Sections C.9 and C.10.

- **Bulk copying:** Determine whether you will allow other organizations to copy significant portions of your holdings outside of FOIA requests. What requirements must the researcher meet to ensure that the park's concerns are met for consultation with culturally affiliated peoples over sensitive materials, compliance with legal requirements, proper NPS attribution via credit lines, and NPS cost recovery?

Note: Bulk copying of NPS collections is generally frowned upon because legal, ethical, cultural, or preservation problems may arise. If individuals or organizations ask to copy entire or significant portions of a NPS-held collection, ensure that they are aware of restrictions that have been placed on use, including further 2-D reproductions from the copy. Screen the materials for donor restrictions, cultural sensitivities, and legal restrictions prior to the copying. Insist on proper captioning and citations of the park collection in all usages. ***The most commonly approved method of bulk copying is microfilming of entire collections for deposit in another archive or library or for scholarly use.*** See Sections C.11 and C. 12. Don't allow copying of materials with donor restrictions.

All bulk copies provided should be clearly labeled as copies and should contain the full citation and credit line (see Sections C.11 and C.12) of the original materials and appropriate copyright warnings. Don't allow bulk copying of materials protected by copyright unless the researcher has received written permission from the holder of the copyright. To maximize park control, your superintendent may require that anyone undertaking bulk copying complete a special use permit.

NPS fees are based upon and used for cost recovery. Each park will have fee schedules based upon the:

- **number and salary levels of staff doing the work**
- **prices of local contractors**
- **supplies used**
- **types of 2-D reproductions being provided**

Once you develop generic cost-recovery procedures based on these figures, you can use these fees for all requests until your costs change. See Chapter 6: Other Uses of Museum Collections.

For commercial filming in the parks, fees may also be based upon the number of days of filming, the size of the film crew, and the amount and type of equipment present.

12. *What sources of additional guidance should I consult?*

See the following publications for further guidance in the creation, storage, housing, and handling of reproduction formats:

- *Museum Handbook*, Part I (*MH-I*), Appendix R: Curatorial Care of Photographs
- *Museum Handbook*, Part II (*MH-II*), Appendix D: Museum Archives and Manuscript Collections, Sections T-W.
- *Conserve O Gram* leaflets, in the categories of Museum Collections Storage, Photographs, and Archival and Manuscript Collections and Rare Books.

B. Preliminary Policy and Planning Considerations

1. *What are the various kinds of 2-D reproductions?*

In archival and museum collections you can find a variety of historical 2-D reproduction processes and formats created using chemical, magnetic, pressure, photographic, photomechanical, and printing techniques, including:

- ***architectural drawing and plan processes:*** aniline prints, blacklines, bluelines, blueprints, chronaflex mylar prints, diazo prints, electrostatic plotter prints, ferrogallic prints, ferroprussiate prints, ink jet prints, magic marker drawings, ozalid prints, photostatic prints, sepia prints
- ***computer printouts:*** daisy wheel, ink jet, laser
- ***digital and magnetic media:*** CD-ROMs, Digibeta (for video), DAT (audio), diskettes, reel-to-reel tape, tape cartridges
- ***drawings and sketches:*** charcoal, conte crayon, graphite, ink, magic markers, pastels, watercolor
- ***early and largely extinct copy processes:*** carbon papers and carbonless copy papers, gelatin dry transfer copies, hectographs, letterpress books and papers, mimeographs, thermographs
- ***facsimile (fax) transmissions***
- ***graphic printing processes:*** engravings, etchings, halftone illustrations, lithographs, woodblock prints (***Note:*** While graphic prints can be original art objects, they were also used frequently before the development of photography in 1839 to distribute copy images of other artwork.)
- ***micrographic processes:*** color, diazo, silver halide, vesicular

- ***motion picture processes:*** cellulose ester, cellulose nitrate, color dye processes
- ***photographic processes:*** albumen prints, collodion processes, cyanotypes, gelatin silver prints and several thousand other processes
- ***photomechanical processes*** (e.g., Woodburytypes)
- ***xerographic copies***

Note: Some of these formats and processes were used to produce both original and copy materials, such as graphic prints, photography, and photomechanicals. Careful examination may prove whether some materials are originals or copies, but it is not always possible to distinguish between the two.

An overview of the relative permanence of these historic formats can be found in *COG 19/14, Judging Permanence for Reformatting Projects: Paper and Inks*. Care and handling instructions can be found in *COG 19/15, Storing Archival Paper-Based Materials*; *COG 19/16, Housing Archival Paper-Based Materials*; and *COG 19/17, Handling Archival Paper-Based Materials*.

2. Who wants these 2-D reproductions?

2-D reproductions are desired by many commercial and nonprofit individuals. These individuals fall into two natural groups:

- ***Museum staff***, including archivists, collateral duty staff, conservators, curators, museum specialists, and registrars, who want high quality, low-cost images such as:
 - ***record photographs*** for placement with catalog records
 - ***condition and treatment photographs*** to document the before, during, and after states of objects undergoing treatment or to document changes, damage, defects, or flaws in an item for insurance or liability purposes
 - ***deposit copies*** for placement at another repository to facilitate research
 - ***duplication master*** to be used when making additional copies
 - ***exhibition copies*** for use in an exhibit or display to replace the original item
 - ***preservation masters*** to use in the production of further duplication masters when existing duplication masters are damaged or deteriorated
 - ***duplication record photographs*** to serve as a record of what has been published or reproduced (Keep publications, as future orders may cite the publication name and page number when placing their order. Maintaining the publication will save you time as you try to fill the orders.)

- **security copies** to serve as back-up copies in case of theft of the original or to take the place of the original in a high risk situation
- **use copies** to save the original item from handling damage
- **Researchers**, including authors, contract researchers, discipline specialists, editors, educators, exhibit designers and writers, film and video production staff and writers, interpreters, park staff, public relations personnel, publishers, reporters, scholars, students, Web designers and writers, and others may want:
 - **deposit copies** placed in repositories near them to facilitate research
 - **fair use copies**, as defined by the copyright law, so that the scholar doesn't have to obtain permission from the copyright holder for research, news reporting, parody, or satire use of the item (Only when the item will actually be published or distributed, must the researcher obtain permission from the copyright holders. See Chapter 2: Legal Issues, for more guidance.)
 - **publication copies** for use in an article, book, exhibit catalog, finding aid, motion picture film, pamphlet, videotape, Website or other publication (**Note:** Researchers from nonprofit institutions often expect to be charged a lesser fee or no fee. Deciding when cost-recovery fees will be waived must be addressed in the park's 2-D reproduction standard operating procedure. Like all NPS procedures, the waiver of cost-recovery fees should be uniformly applied. Waiving fees only for colleagues or friends is discriminatory. Once regularly waived for some people, the waiving of fees must be offered to all other applicants in similar circumstances. Make certain you don't set precedents that will be too costly for the park to follow.)
 - **research photographs** for long-term scholarly work (**Note:** Scholars frequently don't want to worry about intellectual property rights or credit lines as the reproduction is raw material for scholarship. However, if the park doesn't collect any necessary fees up front, it is very difficult to obtain them later.)
 - **sales copies** for use in a derivative work, such as a tee shirt or calendar.

3. *What materials are most frequently reproduced?*

The materials reproduced most frequently are those that have already been exhibited, filmed, interpreted, published, or distributed on products, such as on tee shirts or posters. These materials tend to be:

- **photographs** (the most commonly reproduced items), including:
 - historical photos, particularly portraits, landscapes, and street or park scenes
 - high quality record images of museum objects and specimens
 - interpretive and resource management images of park sites

- **documents**, particularly:
 - autograph materials
 - drawings, including architectural, lighthouse, and ship drawings and plans
 - holographic (handwritten) documents, such as diaries and letters
 - maps
- **moving images**, including:
 - motion picture film footage
 - videotapes, particularly commercial programs and video histories
- **sound recordings**, particularly:
 - oral histories
 - music

Publishing previously unpublished park objects and documents serves the park's preservation goals as published copies reach many individuals who previously had to visit the park and handle original objects. Once published, however, demand to view the item is likely to increase, so it is important to have the original secure and, if possible, well stabilized or to have high quality copies for viewing.

Publishing also serves educational and outreach goals as well as giving authors, exhibit designers, and publishers the opportunity to provide new and interesting materials to the public.

4. *Why should I produce 2-D reproductions?*

You will provide or contract out to provide 2-D reproductions to:

- **meet a basic park staff need** for management control documents that:
 - serve as preservation masters for use instead of the original item
 - serve as duplication masters from which to make additional copies
 - serve as catalog record shots
 - serve as deposit copies for placement in other institutions to enhance access
 - document collection condition
 - document collection treatment, both before and after
 - serve as security copies to be used in lieu of valuable originals

- **enhance visibility** and usefulness of the collections for the public by providing images for use in:
 - articles
 - books
 - brochures
 - collection catalogs
 - derivative works (calendars, tee shirts, CD-ROMs, and other products)
 - electronic publications, such as CD-ROMs and the World Wide Web
 - exhibits and exhibit catalogs
 - family histories
 - research
 - student and staff reports
 - television programs and videotapes
- **increase the level of scholarship** on the National Park Service and particularly the park’s museum and archival collections
- **enhance support** (Leveraging the NPS museum and archival collection contents to raise popular support for and future donations to the NPS is a practical and effective strategy.)
- **help meet professional standards requiring that institutions provide copies for research**, such as the American Association of Museums (AAM) accreditation standards, the AAM Museum Assessment Program (MAP), and the Society of American Archivists (SAA), particularly Figure 4.7, Statement on the Reproduction of Manuscripts and Archives for Reference Use of the Society of American Archivists

5. *How do I set up my park’s 2-D reproduction fee schedule?*

You may recover costs for the work and materials involved in producing 2-D reproductions according to 43 USC 1460. These fees may not be determined by what other organizations charge, but must instead be based upon the actual resource and staff costs of the people doing the work in your park. You may also charge fees for commercial filming and photography work with collections. To figure out the park’s cost-recovery duplication fees you must determine the:

- ***salary and benefit costs per hour of the personnel*** routinely performing the work (***Note:*** If more than one person performs the work, determine the percentage of the time each participant handles the copy orders. Then, pro-rate the work according to the frequency with which the employees undertake it. For example, if a GS-7 collateral duty park

ranger and a GS-11 curator each do the work half the time, the cost-recovery plan fees should reflect an average of the two salaries.)

- **average time** it takes the personnel to perform each of the above steps per item order (See Section C.2, Duplication Fees, and Figure 4.4, 2-D Reproductions Cost Recovery Chart for Estimating Time Spent [Sample], for an example.)
- **cost to produce each type of duplicate** at your local contractors, cooperating association, or in-house service agency (Obtain this information from your contractor or staff member.)
- **special service fees** charged by the contractor on demand, such as for a rush order or special service such as toning, retouching, or darkroom work on a copy print (Obtain this from the contractor.)
- **average peripheral costs**, such as mailing, special delivery, supplies, housing, and boxes or envelopes for copies and originals (Determine this based on supply and postage costs.)

Under Public Law 106-206 you may charge fees for commercial filming and photography. For filming, the cost is determined by the above factors and the number of days of filming, the size of the film crew, and the amount and type of equipment present. For photography, a fee is assessed only if the photography is in a location where members of the public are generally not allowed or where additional administrative costs are likely. All fees from this work go to the Fee Demonstration Program.

Cost-recovery Fee Formula:

Hourly salary and benefit costs (30% of salary) of park staff
x number of hours to do the work (See Section C.2)
+ regular duplication costs of external contractor
+ special service fees and costs charged by contractors for rush orders or services
+ transportation cost and supply costs charged back by NPS

Once the cost of an average item for each of the types of copies you produce is computed, determine the costs of special orders (such as having a negative, print, slide, and transparency produced from an original photograph or microfiche produced from roll microfilm).

Determine the costs of the various special services and orders listed in Section C.2. For an overview of the staff work involved, see Figure 4.4, 2-D Reproductions Cost-Recovery Chart for Estimating Time Spent. Be sure that you have a fee schedule for each reproduction format that you produce. Update your park's duplication cost-recovery fee schedule each time fees from contractors or participating staff salary change. See Section C.2 and Figure 4.4.

6. *Do I have to make all types of 2-D reproductions available?*

No. However, if a type of reproduction is requested that you don't normally provide, you must take reasonable steps to attempt to meet the need.

For example, if you don't normally make copies of motion picture film, but you receive a request for a copy of a film, contact your regional/SO curator

for help in finding a contractor who will take on this work. Obtain cost information from the potential contractor and determine if the copy work would be prohibitively expensive for the researcher, as you would have to set up new procedures to meet the need.

7. *How do I produce these 2-D reproductions?*

You have the following options:

- Train park staff to produce the 2-D reproductions.
- Hire a contractor to reproduce the work following your instructions on how to handle and make 2-D reproductions of archival and museum materials to NPS specified standards.
- Work with a cooperating association to reproduce the work following your instructions as above.

Whichever solution you choose, ensure that the work is done to specified standards. Follow the quality control standards listed in the *Selected Bibliography*.

8. *How should I select and work with a cooperating association or reprographic contractor?*

If a cooperating association or contractor is permitted to digitize selected park holdings for profit-making purposes, you will need to charge for such services as curatorial assistance, security services, and special access during off-duty hours. Inform cooperating associations and contractors in advance of NPS requirements. If your superintendent approves, you may require the cooperating association or contractor to complete a special use permit indicating how and when the materials may be used.

To keep the process simple, the park may determine not to charge cost-recovery fees if the costs to be recovered are less than \$25 or some park-determined amount. When no park fee is charged, you may ask the researcher to send the duplication payment directly to the contractor or cooperating association producing the copy. Direct payment facilitates the work and limits the amount of park paperwork required.

If you decide to work with staff of a cooperating association or contractor for reprographic services, follow these guidelines:

- ***Select your cooperating association or contractor based upon:***
 - ***recommendations*** from fellow professionals (Contact your NPS colleagues, regional/SO curators, archivists, and librarians for referrals.)
 - ***results of a pilot project*** of a selected group of materials that include a full range of text, continuous tone and line art (black-and-white and color images), combined text and images, and similar materials (Send the pilot project to each of the contractors or cooperating associations being considered. Inspect and test the results as described in Sections C and F.)
 - ***an inspection visit*** to the contractor's or cooperating association's laboratory during the pilot project to ensure that the facility is environmentally appropriate and has appropriate equipment

(For example, no equipment should use an automatic feed or force-feed mechanism.)

- ***interviews with contractor’s or cooperating association’s staff*** during the pilot project to ensure that the staff understand appropriate handling, light levels, benchmarks for quality and exposures, metadata requirements (descriptive data about the file, including size, format, document name, and contents), and packaging and shipping needs
- ***Train contractor’s or cooperating association’s staff*** in handling and shipping techniques. Ensure that contractors know to:
 - *leave materials in original order* and never rearrange materials by density and resolution
 - *keep hazardous materials separate* from non-hazardous materials during shipping; for example, keep cellulose nitrate negatives and film in separate sleeves, envelopes, and boxes from polyester copies
 - *provide special handling and shipping for cellulose nitrate materials*, never leaving them in hot rooms, in closed vehicles, or under hot lights
 - *provide new housing for all copies*, never reusing deteriorated housing or housing that has previously held cellulose nitrate or cellulose ester films including acetate, diacetate, and triacetate films, as the old housing will contaminate new 2-D reproductions
 - *use equipment that will not damage originals*, avoiding force-feed equipment when copying NPS materials, as they can cause abrasion, tearing, scratching, and bending of original items
- ***Write a contract, agreement, or memorandum of agreement*** that covers all the issues described above and also holds contractors to the standards listed in the *Selected Bibliography*. See *COG 19/12, Contracting for Reformatting of Photographs*.
- ***Cooperate***. If work will be ongoing, set up a cooperative relationship with the contractor or cooperating association.
- ***Inspect*** all returned originals. Make sure copies meet standards. Use a testing laboratory to check density and residual chemistry of microfilm, film, and photographs.
- ***Avoid over-exposure of the same treasures***. Nothing leads to increased demand for reproductions like past visibility. You will continue to receive regular requests for 2-D reproductions of the park’s best known collections. Many potential cooperating associations are interested in NPS content because it can be useful for education, entertainment, and as an expression of what is best in American culture. NPS museums must strike a balance between access and preservation in making materials available to the public. Simply “skimming the cream” or once again reproducing the top 1% of NPS collections in another format is to be avoided as:

- these materials have already received good exposure
- repeated use may present a preservation challenge for materials, which have been subjected to excessive handling and light exposure

Instead, select materials based upon their value, usage, and risks. See *COG 19/10, Reformatting for Preservation and Access: Prioritizing Materials for Duplication*.

Additional exposure of the same materials should be done in a way to help preserve them while sharing them with the public at little cost, such as publication on the NPS Website. Simply making them available to a contractor who will charge for public access is not as helpful to the public as placing them on the NPS Website.

Encourage proposals to stabilize and research the original object and provide Web access or publication of the copy. If your object is in a condition where only limited use can be supported, favor uses that will provide wide access without charging significant access fees.

9. *How do I maintain control when working with a contractor or cooperating association to produce 2-D reproductions for special projects?*

Maintain control by following NPS requirements on marking, legal issues, contracting, and format usage. Some formats, such as digital files, encourage widespread access (such as via the World Wide Web) and subsequent loss of control. Other copy formats, such as microfilm, provide excellent control, as only poor to moderate quality copies may be made one-at-a-time. See Section B.5 for guidance on commercial filming and photography of park collections and Figure 4.3, Comparison of the Advantages and Disadvantages of 2-D Copy Formats, for guidance on selecting a format.

Look into the contractor's background. If you are working with a contractor or cooperating association for a specific external project that was not initiated by the NPS, begin by learning the basic background on the project, including the:

- project title
- project publication media
- project schedule
- publication release dates
- language(s)
- publisher's and distributor's names
- project manager's name (also address, e-mail, phone, and fax numbers)
- editor's and designer's names (also address, e-mail, phone, and fax numbers)
- length of the proposed collaboration

- whether the park superintendent will receive a written report at the end of the project listing all NPS materials used and indicating how many times, and where each item was used
- whether the contractor or cooperating association plans to donate a portion of the proceeds to the park
- whether the contractor or cooperating association will provide at least two copies of the finished piece for the NPS—one for the library and one for the archives
- whether the contractor or cooperating association will indemnify the NPS from lawsuits and claims as stated in *MH-II*, Figure D.14, Copyright and Privacy Statement

Gather your contract or agreement information. Once you have the basic background information on the project, have your cooperating association or contractor indicate in writing in your agreement or contract, the following information about how the 2-D reproductions will appear in the final work:

- what size they will be
- where they will appear in the final work
- whether or not they may be cropped, compressed, or enlarged in any way
- how and where the caption line and credit lines will appear in the final work (Find out if the captions/credit lines will be next to the item, linked to the item [less desirable] or simply placed elsewhere in the publication with no linkage [least desirable])
- what additional copies or derivatives may be made from the 2-D reproductions
 - whether anything may be superimposed upon it or near it
 - whether the 2-D reproductions may be color corrected, sound engineered, or airbrushed; or have stains removed digitally; or be in any other way altered. ***Note:*** Retouching or enhancing the image produces an inauthentic copy that is significantly different from the original. Such retouching or correction may damage or destroy the evidential value of the copy
 - whether the 2-D reproductions will be used for any special purposes, such as for a frontispiece, book or box covers, advertising copy, or for film trailers
 - whether the NPS arrowhead logo must appear with the 2-D reproductions

Indicate any restrictions. Ensure that you have a clear written contract with the reprographic firm or cooperating association that has been signed by both

parties. Ensure that the cooperating associations or contractors know that having produced the copy doesn't allow them to:

- ***publish, distribute, sell, or use the materials in additional products*** or publications without permission from the park superintendent and the holders of any intellectual property rights and without using the appropriate caption and credit lines (See Sections C.12 and C.14) except for fair use purposes. See *MH-III*, Chapter 2: Legal Issues.
- ***authorize others to use, distribute, or publish the copies without the written permission*** of the park superintendent and the holders of any intellectual property rights and the use of the appropriate caption and credit lines (See Sections C.12 and C.14.)
- ***permanently keep copies after the life of the joint agreement is over*** without the written permission of the park superintendent and any intellectual property rights holders and affiliated peoples
- ***copyright the copies of materials held by the NPS*** without the written permission of the park superintendent and the holders of any intellectual property rights (See Chapter 2: Legal Issues, Sections C.6 and C.7.)
- ***morph or alter the copy, except for purposes of satire or parody,*** without the written permission of the park superintendent and the holders of any intellectual property rights except when requested by park staff to enhance the clarity of the information contained (such as for stain removal)

Specify all uses by the contractor/cooperating association. The contract should stipulate what uses the contractor and cooperating association may make of the reproduced items, if any. For example, may the contractor use the reproduced items in only one edition (one language, one publisher) in only one format (one Website, one book, one videotape)? If the contractor is asking for multiple edition use, multiple title use, or all digital rights, move the discussion to one time use to avoid losing control of NPS content. If the cooperating association or contractor wants to use the materials in all editions, on the box, and on the advertising, each permission must be negotiated and agreed to in writing with the superintendent.

Don't sign any agreements granting anyone "exclusive usage," "exclusive rights," "all rights in perpetuity," or "all galactic rights."

The contract must clearly state under what circumstances (if any) the contractor or cooperating association may make additional copies of the copies for deposit in other institutions or for sales purposes. If you grant usage to one contractor or cooperating association, you must be willing to do so to all others who request it, unless the preservation situation of the works change.

For further guidance see Figures 4.6, Permission to Publish Letter, and 4.8, Wording to be Included in a 2-D Independent Contractor Agreement; and *MH-II*, Appendix D: Managing Museum Archives and Manuscript Collections, Figures D.14, Researcher Duplication Form, D.15, Copyright and Privacy Form, and D.16, Researcher Registration Form. See also Chapter 3: Publications, Figure 3.12, Memorandum of Agreement.

10. *How do I maintain control during digital projects?*

Follow the guidance on maintaining control above under B.9.

- **Indicate who will do any collection preparatory work** required before scanning, such as collections stabilization or flattening and opening documents.
- **Identify the descriptive conventions**, particularly how and when the scanning contractor or cooperating association will do the file naming, numbering, indexing, and labeling.
- **Indicate what file formats and compression schemes** the scanning contractor or cooperating association will use.
- **Identify who will handle quality control testing** of files and metadata.
- **Identify who will use a digital watermark** stating “NPS” on original and on all the copies. See the definition of watermark in Section A.9 for more information.
- **Ensure that the contractor’s or cooperating association’s network is sufficiently secure** to prevent unauthorized downloading, transferring, copying, and manipulation of content. Avoid using non-secure formats, such as floppy diskettes, for distribution.
- **After the digitizing project is over the park should receive:**
 - *copies of all digital master files* (uncompressed TIFF files)
 - *copies of all derivative files* in various file formats, compression schemes, and sizes (thumbnail JPEGs, 200 dpi GIF, and so forth)
 - *copies of all metadata* (descriptive data on files)
 - *copies of all quality control test results* if the work is done outside the park
 - *copies of all indices*

11. *How do I maintain control during microfilming projects?*

Follow the guidance on maintaining control above under Section B.9. If an outside organization requests the right to microfilm selected park holdings, be aware that more work is involved in microfilming than in many copy activities.

- **Identify each party’s role.** Will it be the park or contractor/cooperating association that will:
 - *do any collection preparatory work required before filming*, such as loosening tight bindings or flattening and opening documents
 - *work with a conservator* to stabilize any deteriorated, fragile, or damaged items prior to filming

- *identify any missing items* or pages, locate, and replace them prior to filming
- *prepare targets* (internal labels for shooting next to museum materials) including credit lines (see Section C.12), tables of contents for each roll and each collection or groups of materials, resolution (focus) charts, bibliographic data (creator, title, date, media, publisher, if any, and date) and indications of missing documents or items for a series of linked materials
- *produce a table of contents for the entire project*
- *ensure that microfilm targets (internal indexing) are accurate, legible, and according to park requirements*
- *arrange the materials* for shooting in original order
- *quality control check* to ensure that nothing was rearranged out of original order during shooting
- ***Set up timetables*** for this work.
- ***Determine the quality control standards*** to be followed.
- ***After the microfilming project is over, check that the park receives:***
 - *the negative* of the microfilm plus a full set of copies
 - *a copy of all targets* or indices to the microfilm
 - *copies of all quality control test results*, including methylene blue tests and densitometric tests

See *COG 19/21, Planning for Microfilming Projects*, for further guidance.

12. *How do I maintain control for motion picture film and photography projects?*

If an outside organization requests the right to film or photograph selected park holdings:

- ***Indicate when and for how long the film may be used***, for example, for non-commercial usage on National Public Television for a five-year period.
- ***Indicate how long the photography may be used***, for example, in a single edition of a single English language publication or on a Website for five years.
- ***Ensure that the director and producer understand clearly and state in writing when and how the photography and film may be used.***
- ***After the filming or photography project is over, check that the park receives:***

- *all negatives plus a positive print or transparency* of each item, preferably on a long-lived film stock such as a polyester film base
- *copies of all final edited or retouched versions* and any outtakes or unused film footage
- *copies of all quality control tests* including densitometric tests and resolution tests
- *copies of any captions, indices, or directories*

See Section B.5 on commercial copying and Chapter 6: Other Uses of Museum Collections, Section C, for further guidance.

13. *How do I maintain control over collections for audiotaping and videotaping projects?*

If an outside organization requests the right to record selected park on audiotape or videotape:

- ***Indicate when and for how long the tapes may be used*** in concerts or broadcasts, for example, for non-commercial use on National Public Radio or Television for a 25-year period.
- ***Ensure that the director and producer understand clearly*** and state in writing when and how the tapes may be used.
- ***After the taping project is over,*** check to make sure the park receives :
 - *all master tapes plus an edited copy*, preferably on a long-lived tape stock such as professional quality reel-to-reel tape or short-play professional quality cassettes (<60 minutes per cassette) or on CD-ROM (For more information see *COG 19/19, Care of Archival Compact Discs*, and *19/20, Care of Archival Digital and Magnetic Media.*)
 - *copies of all final versions* and any outtakes or unused tape footage
 - *copies of any indices or directories*
 - *copies of all quality control tests*

See *MH-I*, Appendix C: Professional Organizations, for a list of groups that may be of assistance.

14. *How do I maintain control over printed and xerographic reproduction projects?*

If an outside organization requests the right to make printed or xerographic copies of selected park holdings:

- ***Ask to see all page proofs and bluelines*** to ensure that the object is reproduced correctly.
- ***After the printed or xerographic duplication project is over, ensure the park receives:***
 - *copies of page proofs and bluelines* for review purposes

- *two sets of the publication* (one for the library, one for the archives)
- *preservation and duplication master copies* on high quality acid-free paper with carbon-based laser toner for park use
- *a copy of any indices* to the copies
- *copies of all quality control test results* on the paper and toner

15. *How should I operate if I choose to do the work in-house?*

If you choose to do the work in-house:

- **Professionally train** your staff by sending them to courses sponsored by professional organizations.
- **Gain practical experience before beginning.** Ensure that your staff members doing the copy work obtain some practical experience through cross training or a detail with a major professional organization that does reproduction work to national standards.
- **Be aware of hidden costs.** Don't expect that the work will be done more quickly, cheaply, or easily if it is done in-house. **There is a very steep learning curve with most 2-D reproduction work** (all but xerographic copies) that may ultimately make it more cost effective to contract out, unless your staff has significant prior experience with reformatting.
- **Do effective quality control and reproduction testing.** Test and inspect in-house work just as you would contract work. See Section C.3 and the Selected Bibliography.

16. *How do I keep control of my content when producing 2-D reproductions in-house?*

When undertaking reproduction programs:

- **Don't allow researchers or untrained park staff to do the copy work** or to use their own equipment. The NPS should attempt to control handling and be responsible for legal (copyright, privacy, and publicity issues), ethical (donor restrictions) and cultural issues (Archaeological Resources Protection Act [ARPA] restrictions, and cultural sensitivities) relating to access and use of NPS collections. Allowing others to copy materials without careful supervision can lead to ongoing donor, legal, and cultural relations problems.
- **Don't allow park staff, volunteers, vendors, contractors, cooperating associations, or others to copyright their 2-D reproductions of your museum materials.** The copyright may pose significant confusion and access problems in the future. Some digital publishers and contractors are copyrighting their individual digital copies of public domain materials, even when the original items are already covered by copyright held by others. The lawsuit *The Bridgeman Art Library vs. Corel Corporation* in Federal District Court in New York of November 1998 indicates that mechanically produced reproductions of 2-D materials may not be copyrighted as they lack sufficient originality to qualify as an original art work. See Chapter 2: Legal Issues, Sections C.6 and C.7.

Most publishers copyright their entire work (book, journal, Website) even when they don't own the copyright to some individual pieces within

the publication. Such copyrighting of an assemblage of pieces doesn't change the copyright status of individual items already copyrighted or in the public domain. Copyrighting of a work that contains public domain materials serves as a notice that the publisher considers the sequence of content to be an original work capable of being protected under the law.

Don't authorize a contractor or cooperating association to place a copyright notice on an individual NPS-owned item and claim copyright ownership of something that is already in the public domain or whose copyright is held by another.

Such placement of a copyright notice on an unprotected or already protected item implies that the contractor or cooperating association has some control over the access and use of the original item. This is not true. Placing a copyright notice on something that is in the public domain or already is copyrighted is simply an ineffectual and misleading gesture.

- ***Don't allow park staff, volunteers, vendors, contractors, cooperating associations, or others to keep master images or files***, such as the photographic negatives or digital master file unless you have a signed agreement. The agreement must indicate that the NPS owns the material and controls access and the cooperating association is committed to preserving, migrating, and managing the materials on behalf of the NPS over time.

Many copy laboratories will argue that they can store and manage park duplication masters better than parks, particularly since shipping the duplication masters isn't necessary when the park wishes to place subsequent orders. Once you have lost physical control of the master, it may be difficult to regain it or legal title to the materials. See Figure 4.7, Wording to be Included in 2-D Independent Contractor Agreement, and Chapter 3: Publications, Figure 3.12, Memorandum of Agreement.

Don't store park 2-D reproduction masters with park contractors or cooperating associations unless the park has a very clear and specific agreement signed by both parties, stating:

- ***precisely what services will be provided and at what cost***
- ***how the materials will be handled and used***
- ***that 2-D reproductions may be made only with written permission of the park staff***
- ***that the park owns the materials and can regain custody when required***
- ***precisely what materials are covered by the agreement in inventory form***

Keep all masters in the park, as this will allow the park to control access and use, monitor usage, and limit risk, such as intellectual property right infringements and inappropriate use of sensitive or confidential data. See Section B.9.

- **Don't allow researchers to deliver the materials to the copy laboratory themselves.** Researchers are not park staff. If the researcher loses the material, the park would be in a very awkward position legally. Either have park staff deliver the items or hire a delivery service.

17. *Is approval necessary before 2-D reproductions are made?*

Yes. Items must not be removed from museum storage for any non-research or reference purpose without archival/curatorial examination and approval. Determine if the object is stable and capable of being handled and reproduced. In some cases, it may be necessary to work from a copy image or object rather than reproducing from the original.

18. *How do I handle requests for photographs of original archival and museum materials?*

Researchers and park staff often require 2-D reproductions of museum objects. Staff may want usage, duplication, or reference copies to serve as surrogates for the originals. Researchers generally want copies for publication or scholarly purposes. Handle all requests in the same manner:

- **Document the request.**
 - *Ensure that all appropriate forms are completed* and that the researchers sign them. (See *MH-II*, Appendix D: Museum Archives and Manuscript Collections, Figures D.14, Researcher Duplication Form, D.15, Copyright and Privacy Form, and D.16, Researcher Registration Form.)
 - *Ask for copies of all final edited or final program versions* and any outtakes.
 - *Request that a clear credit line and caption line* always accompany the item in all products (see Section C.12).
 - *Inform users that having a copy doesn't allow them to use the materials in additional or later programs, films, tapes, performances, products, or publications* without obtaining additional NPS approval and written permission.
- **Examine the item.** Determine if the objects/items require stabilization or are particularly vulnerable to handling or light damage during reformatting. (See Section B.19.)
- **Stabilize the item.** If necessary, send the object to a conservator for treatment prior to reproduction.
- **Work with a museum objects photographer.** Ask your regional/SO curator for assistance in locating a trained photographer. See *MH-II*, Appendix L: Photography.
- **Arrange for a cost-recovery payment.** See Section B.8.
- **Ensure that the park obtains all copyright and model release forms** from the original image creator and all master images, such as original negatives, and that no copies or negatives stay with the photographer when the park is funding the request.

- **Ensure that your contract or agreement clearly states that the park owns all copyrights** and receives all model and interview release forms, as well as all negatives, slides, transparencies, prints, digital files, etc. See Chapter 3: Publications, Figure 3.4, Assignment of Copyright by Contractor (Sample).
- **Ensure that the researcher funds any and all processing costs, including negative production if necessary.** Most museums and archives require that the researcher fund not only their copy, but also the production of a negative or other master image that stays with the museum if no such master image or negative already exists. Your policy should indicate that the park receives the duplication master (the negative) and the preservation master (the transparency) if the work is being funded by an outside agency and the park doesn't already have masters for these purposes.
- **Don't loan, sell, or distribute duplication or preservation masters to researchers,** as the park may lose control of the intellectual property rights and the ability to manage the sensitivities and usage context. Instead, share usage copies, which may be photographic prints, xerographic copies, smaller digital files (around 72 dpi) and non-broadcast quality materials.
- **Ensure that the original object is handled appropriately** and replaced in storage.
- **Compare the copy image** side-by-side with the original item for quality, completeness, focus, tonal range, and other issues. See COG 19/13, Preservation Reformatting: Inspection of Copy Photographs.

19. *What items require examination and/or stabilization before being copied?*

Examine all items to ensure that they are not too fragile, faded, or damaged to be handled, transported from storage, or lit for reproduction. Many items may need to be treated or stabilized by a conservator. This section will alert you to potential problems and vulnerabilities when materials are placed in new environments such as photo laboratories with their resulting changes in temperature and humidity, strong lighting, rapid handling, and transportation difficulties. Among the items that are particularly vulnerable to the handling, humidity and temperature changes, and light damage that often accompany reformatting are:

- **photographs**, including:
 - *cased images*, such as daguerreotypes, ambrotypes, tintypes, opalotypes, and similar images (**Note:** Although cased images may be very difficult to copy due to dirty or deteriorating cover glasses, copyists must be warned not to dismount the original case, frame, and cover glass assemblage or they may destroy the items.)
 - *cellulose ester*, including acetate, diacetate, and triacetate negatives, transparencies, and X-rays (**Note:** These materials may give off acetic gases that damage nearby materials. Cellulose ester images must not be housed, packaged, or shipped with non-cellulose ester materials.)

- *cellulose nitrate*, particularly as nitrate negatives, X-rays, motion picture film, and aerial photographs (**Note:** Nitrate is a fire, health, safety, and structural hazard unless stored at a low temperature and humidity and kept far from sources of ignition. Nitrate materials must not be housed, packaged, or shipped in containers with non-nitrate materials.)
- *ferroprussiate process prints*, including cyanotypes and blueprints (**Note:** These items are extremely susceptible to fading under strong light and have very weak paper fibers. See *COG 19/7, Care of Blueprints and Cyanotypes.*)
- *glass plates*, including albumen photographic transparencies, autochromes, collodion wet plate negatives, collodion dry plate negatives, lantern slides, opalotypes, silver gelatin dry plates (**Note:** Glass plates may be broken, cracked, or chipped and/or have flaking emulsions. Glass plates generally are fragile and require attentive handling/shipping to ensure that no two plates touch each other.)
- *paper-based images*, particularly wood pulp paper (**Note:** Paper materials are susceptible to environmental damage, particularly light damage. Light can bleach and weaken paper fibers, as well as fade media and dyes.)
- *shaped and curved images*, such as stereographs (**Note:** The natural curve of the image and base will not lay easily on the platen of a scanner or xerographic copier. Older stereographs can separate from their bases, posing additional stabilization and copy problems.)
- **books**, which may need to be either individually copied on a rare-book-equipped copy machine that has V-shaped special book edges (allowing books to be copied without pressing them flat) or copied with special book cradles to keep their bindings intact. Avoid any sort of automatic feed mechanism as well as any copy equipment that requires placing pressure on the book spine. Additional book problems requiring stabilization include acidic pages, flaking due to red rot, loose or missing pages, illustrations, such as photographs or maps, that must be copied in the middle of text (posing particular problems when you are using xerographic copying or digital copy technologies).

Other book reproduction problems include:

- *albums, scrapbooks, historical leather bound volumes, and rare books, which are often:*
 - damaged on their spine or covers
 - difficult to work with unless you have a book cradle for shooting (placing them flat may destroy their bindings)
 - distorted or warped dimensionally
 - experiencing mold, insects, or vermin problems
 - fragile, brittle, and acidic, requiring a book cradle to view them
 - full of affixed objects that are falling off, requiring reattachment and documentation
 - suffering red rot (flaking or powdering leather) on covers and spines

- *tightly bound books and books with narrow gutters (inner margins), which may be:*
 - awkward to handle
 - difficult to copy without destroying the binding or disbinding the book
- ***magnetic media***, including:
 - *audiotapes*, which have a media life expectancy of 50-100 years depending upon their base materials
 - *digital reel-to-reel tape*, which has a media life expectancy of 30 years (if the base is polyester) and a software/hardware life expectancy of 3-5 years
 - *diskettes*, which have a media life expectancy of 10-15 years and a software/hardware life expectancy of 3-5 years
 - *tape cartridges and cassettes*, which have a media life expectancy of 5-50 years but a software/hardware life expectancy of 3-5 years
 - *videotape*, which has a media life expectancy of 30-100 years depending upon the media base

(Note: These materials can have bases, such as cellulose ester, that are unstable; flaking media; and coatings, all of which are sensitive to environmental changes and the shock of handling and transportation.)

- ***manuscripts***, including:
 - *letterhead holographic letters*
 - *diaries*
 - *memoranda*
 - *notes*
- ***museum objects***, which are often fragile, very large, high-value, and heavy, and which may require special packing, handling training, copy set-ups (a risk in themselves in tight storage spaces), and cameras to be effectively photographed, including:
 - *decorative arts materials*, such as: basketry, ceramics, furniture, glass, jewelry, medals
 - *archeological objects*, such as: basketry; bone and ivory objects, including jewelry and sculptures; ceramics, including pots, vessels, and similar containers; metal objects, including tools and weapons

(Note: These and similar materials may be too fragile for easy transportation, thus requiring in-park photography to produce a 2-D image of a 3-D object.)

- *artwork*, such as: architectural fragments; art on paper, including graphic media, photographic media, and photomechanicals (**Note:** These items are extremely susceptible to environmental damage, particularly light damage. Light can bleach and weaken paper fibers and fade media/dyes.); framed and/or matted items, which may require careful removal of frames and mats before photography; friable media, including charcoal, conte crayon, pastel drawings, pencil sketches, and similar images or documents with smearable, loose media. (**Note:** The surface of these media must never be touched, placed directly on a glass platen, have a glass or plastic sheet placed upon them to hold them flat or otherwise be touched. Keep light levels relatively low and for relatively brief duration.); graphic prints, including engravings, etchings, intaglio, lithographs, and wood engravings; paintings, including watercolors (**Note:** Paintings can have fragile surfaces and light-sensitive media.); sculpture
- *natural history specimens*, including: specimens in alcohol, specimens in formaldehyde in glass jars, specimens with arsenic or other chemical contamination

(**Note:** These materials, which may be contaminated with potentially dangerous chemicals, may require special packing, handling training, copy set-ups, and cameras to effectively portray a 3-D object in a 2-D image. While 3-D digital imaging systems exist, none of the currently available systems offers full 3-D imaging capabilities at a reasonable cost, although this eventually will become possible.)

20. *Should I allow researchers to make private 2-D copies of museum objects with personal equipment?*

No, although visitors are generally free to take photographs of items on exhibit. While you may allow photography of some materials without legal, management policy, or sensitivity concerns, when possible provide copies rather than allowing private photography or digital copying of museum or archival collection items. Such activity may pose serious problems that are described below. **Your duplication standard operating procedure should discourage the use of private imaging equipment**, including personal digital cameras, scanners, and cameras. Instead, researchers should obtain appropriately marked fair use copies from the park See Chapter 6: Other Uses of Museum Collections, Sections C and D. Allowing the creation of private 2-D copies of public collections may cause:

- **disruption** of museum research spaces or storage or work areas to accommodate a single individual
- **intellectual property rights concerns**, as the user now has a publication-quality image, which may be used without regard to copyrights, privacy rights, and publicity rights
- **potential liability problems**, if the copyist inappropriately publishes the item without obtaining permission from the holder of the intellectual property rights
- **preservation problems**, as non-custom copyists handle items for the speediest copy work, often ignoring the damage they cause to originals

- ***public relation concerns with affiliated group and other stakeholders***, when the copyist produces a publication quality copy that is then used inappropriately or inaccurately without consulting affiliated groups
- ***public relations concerns with scholars and the general public***, when the copyist publishes the item with inaccurate or inappropriate information alongside the NPS credit line
- ***supervisory responsibilities***, as staff must constantly monitor for inappropriate handling

Museum object documentation of fine and decorative arts materials, some ethnographic materials, and archives by a private individual or firm may pose a legal threat to effectively managing copyright and privacy/publicity rights and restricted collections. While biological, archeological, and similar objects aren't intellectual property concerns, they can be damaged if not handled with great care. Light damage from copy stands can also pose problems. **Note:** This is generally not a concern for natural history specimens or archival collections already screened for problems if they are to be microfilmed for scholarly uses, for preservation, or for deposit in another library.

Some copy agencies are copyrighting their digital reproductions of original works even when the copyrights of the original works are held by public museums or are in the public domain. Don't allow this to happen to NPS collections. The NPS museum collections are held in trust for the public and must not be misrepresented by false copyright claims or usage that violates NPS policies, procedures, and protective legislation.

21. *What notice should I place on all copies?*

According to Section 108 of the U.S. Copyright Act, you must place a notice of copyright directly upon the copies the park provides to users. You may rubber stamp the items, write the notice upon the copy by hand, or use a viewable digital watermark.

- If the original work includes a formal copyright statement, use the following notice:

The work from which this copy was made included the following copyright notice: (Transcribe the original notice and place it here.)

- If the work to be reproduced doesn't contain a copyright notice, place the following notice on it:

The work from which this copy was made did not include a formal copyright notice. Copyright law may protect this work. Uses may be allowed with permission from the rights holder, or if the copyright on the work has expired, or if the use is 'fair use' or within another exemption. The user of this work is responsible for determining lawful uses.

C. 2-D Reproductions Management Implementation Issues

1. *What management issues apply to all kinds of 2-D reproductions?*

A number of issues apply to all reproduction work, regardless of process and format. These include:

- **legal issues**, such as copyright, privacy legislation, publicity legislation, obscenity, Freedom of Information Act, Archaeological Resources Protection Act, National Historic Preservation Act Amendment of 1980, Executive Order 13007-Indian Sacred Sites (May 24, 1996), Federal Cave Resources Protection Act, and Endangered Species Act of 1973

For guidance on these and other legal and ethical issues, see Chapter 2: Legal Issues, and Chapter 1: Evaluating and Documenting Museum Collections Use, Section E, Cultural Issues.

- **procedural issues**, such as adequacy of researcher supervision, fragility of materials to be reformatted, the need to catalog materials that are reformatted, sensitive or restricted data, consumptive use concerns, maintaining the chain of custody, how to handle contaminated and/or hazardous materials (such as cellulose nitrate), establishing a park access and use policy, and setting up user fees

See Chapter 1: Evaluating and Documenting Museum Collections Use, Section C, Management Issues, and *MH-I*, Appendix D: Museum Archives and Manuscript Collections, and Appendix R: Photographs.

- **ethical issues**, such as donor restrictions, equality of access, confidentiality and privacy, preservation, employee ethics, and professional ethics

For more information, see Chapter 1: Evaluating and Documenting Museum Collections Use, Section D, Ethical Issues.

- **cultural issues**, such as sacred ceremonies and sites, circumstances of usage, and authorized users and cultural privacy

For more information, see Chapter 1: Evaluating and Documenting Museum Collections Use, Section E, Cultural Issues.

- **scientific issues**, including concerns about information on the location of threatened and endangered species

For more information, see Chapter 1: Evaluating and Documenting Museum Collections Use, Section F, Scientific Issues.

- **preservation and protection issues**, such as assessment of the original object's physical condition, care and handling of originals (such as cellulose nitrate, cellulose ester films, and glass plate negatives as well as deteriorating museum originals of all kinds) and copies, an overview of potential preservation risks, an overview of security risks, including theft and vandalism, how to evaluate risks, how to recognize and prevent

overuse, how to mitigate damage, and how to migrate and refresh electronic and magnetic media

See Chapter 1: Evaluating and Documenting Museum Collections Use, Section G, Preservation and Protection Issues, and *MH-I*, Chapter 3: Preservation: Getting Started, and Appendix M: Management of Cellulose Nitrate and Ester Film.

- **interpretive issues**, such as the interpreter's role in making and using reproductions, determining the appropriateness of the proposed use, and exploring alternatives to the proposed reproduction or use

See Chapter 1: Evaluating and Documenting Museum Collections Use, Section H, Interpretation Issues.

- **documentation issues**, such as how to document access and use of collections, when to use an outgoing loan agreement, when to require a special use permit (such as for bulk or commercial copying), and when to expand ANCS+ cataloging records (when you lack item-level control)

See Chapter 1: Evaluating and Documenting Museum Collections Use, Section J, Documentation, and *MH-II*, Chapter 5: Outgoing Loans.

2. *What 2-D reproduction procedures should I set up for my park?*

Each park needs to set up these basic 2-D reproduction procedures:

- **Researcher Duplication Form:** This form captures the basic information on the researcher's request and requires the researcher to acknowledge that the use is for non-commercial and non-profit research, news reporting, criticism, and commentary purposes only and not for publications and derivative works. Some information on the form, such as name, address, and affiliation, should be checked against picture identification cards, such as drivers' licenses and employment identification cards. See Question 3 below and *MH-II*, Appendix D: Administration of Archives and Manuscript Collections, Figure D.14, Researcher Duplication Form (Sample).
- **Copyright and Privacy Restrictions Statement:** This statement warns the researcher that permission to publish, exhibit, perform, reproduce, prepare derivative works (such as posters or tee shirts) from, or distribute the item must be obtained by the researcher from the individual(s) who hold the rights (not necessarily the NPS). See *MH-II*, Appendix D: Museum Archives and Manuscript Collections, Figure D.15, Copyright and Privacy Restriction Form.

Researchers sign the form to indicate that they:

- understand their responsibilities regarding intellectual property rights
 - agree to the park's terms including indemnifying or holding the NPS harmless from legal claims arising from the researchers' use of the item
- **Duplication Fee Schedule:** The fee schedule is given to researchers to alert them to the park's cost-recovery fees for duplication services. After reviewing the fee schedule and selecting images for duplication,

researchers must complete Researcher Duplication Forms (*MH-II*, Appendix D: Museum Archives and Manuscript Collections, Figure D.14) correctly and completely.

- **Order Process:** The park staff begins the order process by:
 - *identifying and retrieving* the item being requested
 - *determining the intellectual property right status* of the item requested (privacy, publicity, and copyrights) by checking the deed of gift
 - *checking the requested items* for damage, health and safety issues, and/ or legal or preservation risks
 - *answering the request* in person, or via mail, phone, e-mail, or fax (All responses should be prompt, or at least within 20 days, to acknowledge receipt of the order, explain the park duplication policy, indicate any cost-recovery fees, and cite any duplication restrictions due to the copyright status of the item.)
 - *stabilizing the item to be duplicated*, if necessary; if not possible, creation or location of a duplication master to serve as the original for duplication purposes
 - *rehousing the item and copies* (if necessary)
 - *labeling the item and copies* (if necessary)
 - *packing the item and copies* (if the item is being shipped)
 - *completing all loan or other necessary forms*
 - *depositing any researcher payments* into the appropriate account (**Note:** Reproduction work should not be done without first receiving all payments, as the NPS is not set up to handle billing and debt collection.)
 - *transporting the items to contractor or staff* responsible for duplication, and if necessary, completing their duplication order form
 - *unpacking and checking-in items* after duplication
 - *inspecting returned originals for deterioration* or missing items
 - *inspecting copies* against originals for outside researchers to ensure image completeness, appropriate focus, color balance, and similar visual issues
 - *reordering of duplicates for any missed items* or items that don't pass inspection
 - *quality control testing* of any copies for internal use

- *producing captions and citations*
- *rehousing (if necessary) and refiling the original material*
- *verifying payment of contractor and park by researcher*
- *completing any necessary paperwork, including cover letter to researcher*
- *packaging and mailing of duplicate to researcher*

3. *What is the standard operating procedure for obtaining 2-D reproductions?*

Obtaining 2-D reproductions is a simple process that is the same for staff as for visitors:

- **Flag or list the originals.** The researcher determines what will be reproduced.
 - *For archives*, the researcher marks that item by placing a reproduction flag next to it. A reproduction flag is a stiff, 3"x11" piece of acid-free paper. Place the flag in the archival storage box immediately in front of the item to be reproduced. If it is not absolutely clear which item should be copied, note in pencil on the top of the flag the item location or a unique identifier, for example, box 1, folder 6, item 9, and erase or strike out any previously marked location information. See *MH-II*, Appendix D: Museum Archives and Manuscript Collections.
 - *For museum objects*, make a list of all items to be reproduced including their catalog numbers, object/specimen names, and locations

Attach this list to the Researcher Duplication Form. **Note:** This procedure should be followed when retrieving items for duplication, regardless of the reason. Follow the guidance in *MH-II*, Appendix L: Photography, when making photographs of 3-D museum objects.

- **Register the request.** The researcher completes a researcher request form, copyright and privacy form, and duplication request form completely and legibly. See Chapter 2: Legal Issues, and *MH-II*, Appendix D: Museum Archives and Manuscript Collections, Figures D.14, Researcher Duplication Form, D.15, Copyright and Privacy Restrictions Form, and D.16, Researcher Registration Form.
- **Check the forms.** Ensure that the researcher has completed researcher registration, copyright and privacy, and researcher duplication forms completely, clearly, and legibly.
- **Evaluate the request.** The responsible park staff member examines the request and determines whether the copy can be provided given:
 - *the legal (copyright, privacy, and publicity, and legislation) status of the items requested for copying (Note: If the copyright status is unknown, grant only “fair use” of the materials. See Chapter 2:*

Legal Issues. ***The researcher, not the park, is responsible for obtaining permission to publish.*** If the image is of a private living individual and the park lacks a model release form, don't duplicate it as the image may be protected by privacy legislation. If the individual shown is a park staff member or no longer living, you may duplicate the image.

- *the preservation state of the original item*
- *the proposed usage* (publication or use in a for-profit product) of the copy
- *any special concerns* related to NPS management policy (for example, the original item is NAGPRA-eligible and requires consultation with affiliated groups prior to use)

Note: During evaluation, Cellulose nitrate and cellulose ester (acetate, diacetate, and triacetate) materials may be judged too dangerous and deteriorated to be removed from cold storage for publication purposes. Researchers and duplication staff may be instructed to work with copy negatives instead. Some materials are restricted by other laws or management policy.

Usage for research that doesn't involve publication—such as limited distribution for not-for-profit education, and publication for news reporting, parody, or satire—doesn't require copyright permissions. However, if a copy is made during some other activity, such as conservation treatment, the user must be notified that there may be legal or other restrictions on the use of the reproduction.

Any reuse, even in a later publication or lecture for education or training purposes, may be prohibited unless permission is obtained. See Chapter 1: Evaluating and Documenting Museum Collections Use, and Chapter 2: Legal Issues.

The researcher must obtain a statement from the copyright holder authorizing the use if:

- the use doesn't fit the fair use criteria described in Chapter 2: Legal Issues
- the park doesn't have all copyrights (Check the deed of gift and accession file.)
- the work isn't in the public domain (See Chapter 2: Legal Issues.)
- the park staff can't find any documentation of any sort on the copyright status of the work

The copyright holder's statement (a model for use by researchers seeking to obtain permission to publish, distribute, perform, exhibit, or prepare derivative works from park-held copyright protected materials) should be modeled on Figure 4.6. The statement should say:

“I _____ (full name of copyright holder) *authorize the applicant* _____ (full name of applicant) *to publish (or exhibit, distribute, perform, or film, or whatever is agreed to) the following item* _____ (describe the item by creator, date, catalog number, and title) *in the following publication* _____ (list the publication by title, author, publication date, edition and language; if an exhibition, list museums, travel schedule, dates, title, and sponsor; if for classroom use, list the course title, dates, school, method of distribution, and audience).”

Signed _____

This statement should be signed by the copyright holder, with the copyright holder’s name, address, phone number, fax number, and e-mail address following the signature.

This copyright statement authorizes the use if the researcher plans to publish, re-sell, exhibit, perform, or distribute the item (including over the Web).

Or, alternatively, the researcher can indicate in writing on the Researcher Duplication Form (*MH-II*, Appendix D: Museum Archives and Manuscript Collections, Figure D.14) that he/she won’t use the image in publications, exhibits, performances, or derivative works. Check the accession and catalog folders of the requested object to see what intellectual property rights the park has and what other restrictions (donor restrictions) may apply.

Ask yourself:

- Has the researcher obtained any necessary permission(s) for copyright, privacy, and similar issues?
- Is the researcher proposing to do anything he/she shouldn’t given the intellectual property rights status of the work?

Note: Any use from which money is made in any way requires copyright permissions unless the work is in the public domain. See Chapter 1: Evaluating and Documenting Collections Use, and Chapter 2: Legal Issues, for further guidance.

- **Inform the researcher.** Confirm the request as soon as possible (at least within 20 days) using the same communication media used by the researcher, for example, if the researcher called, return the call; if the researcher wrote, reply in writing.

Inform the researcher of the:

- park publication policy
- arrangements necessary to have copies made (prepayment, signed forms)
- cost-recovery fee schedule and a rough estimate of the cost of the requested work
- permissions that the researcher must obtain elsewhere

- restrictions making the use of the item impossible (Check the accession and catalog folders to find the deed of gift or any related correspondence detailing this.)

If the original to be copied lacks an original negative (duplication master) or if the type of copy requested would require contracting with an outside professional for image production, notify the researcher immediately. Alert the researcher that each required service has an equivalent cost-recovery fee. Ensure that the researcher knows that all negatives, including those he/she pays for, stay at the park.

- **Collect cost-recovery payments in accordance with 43 USC 1460.** The researcher indicates if he/she wants to proceed and provides payment for the estimated cost of the work. The park policy should indicate what forms of payment are acceptable, for example:
 - *cash*, which requires a written receipt and may induce
 - *credit cards*, which result in a partial loss of revenue due to fees by the company and may be stolen, resulting in no payment
 - *money orders*, which are always safe although somewhat inconvenient for researchers
 - *personal checks*, which sometimes bounce and must be addressed by bill collectors

These cost-recovery fees are based upon a park-derived formula. The money is then deposited in the park's account for use by the museum program to furnish future copies. See Section B.5 for information on how to determine fees.

- **Complete an outgoing loan form.** The responsible park museum staff member completes an outgoing loan form (form 10-127 Rev.) for any item to be duplicated away from the museum. If the reprographics laboratory is in the park, the museum staff member packs the item (if necessary) and transfers it.

You can minimize risk of loss or damage and avoid any outgoing loan by having the outside laboratory do the image capture in the park. **Note:** Generally courier delivery is the safest way to arrange delivery to an outside contractor or cooperating association's laboratory. Never let the researcher deliver the item to the laboratory.

For further guidance on outgoing loans, see *MH-II*, Chapter 5: Outgoing Loans, and *MH-I*, Chapter 6: Handling, Packing, and Shipping Museum Objects.

- **Arrange for photography.** Select a photographer and set up any agreements or complete any necessary paperwork. Warn photographers of any health or safety hazards, such as deteriorating cellulose nitrate film. Alert the photographer if he/she should expect any unusual processes, formats, or genres of images, such as glass plate negatives, specimens with asbestos, or moldy or previously vermin-infested items.

For more information on museum object photography, see *MH-II*, Appendix L: Photography.

- **Prepare a credit line and draft caption text.** While the item is being photographed or copied, prepare the credit line and caption to accompany the image. Check any necessary facts while the materials are being copied. See Section C.12 for details and Chapter 3: Publications, Section C.18.
- **Inspect the original and the copies:** Upon receipt of the returned original and copy, inspect the original's condition to ensure that it wasn't damaged during the copying.
 - *For 2-D originals and copy images*, place the original and copy side-by-side on a clean, color-corrected viewing station (matching computer monitors or color balanced light tables) and examine the two images against each other visually and against the photographic order form.
 - *For 3-D original objects and copy images*, place the original object on a safe, clean, and level space next to the color-corrected viewing station that has been electronically calibrated by a computer professional to maintain proper color balance between the monitor, the central processing unit, and the files. Examine the copy visually against both the original and against the photographic order form.

Ask yourself the following questions about the copy:

- Is the copy in the desired process, size, format, and configuration?
 - Is the copy as described on the request form?
 - Is the copy an accurate and complete reproduction of the original? Is anything missing?
 - Is the copy acceptably sharp with a good tonal or audio range and/or color balance or sound that matches the original?
 - Is the copy usable/acceptable as a document?
 - Does the copy require any specific testing such as methylene blue testing or densitometric testing before being provided to the researcher? (**Note:** Generally this will be done only upon request or for materials being added to NPS collections. See *COG 19/13*, Preservation Reformatting: Inspection of Copy Photographs.)
- **Test the copies.** If testing of the copies is required, a loan form is prepared for the copy items, which are packaged and delivered to the testing laboratory using a courier service. Upon return, the testing results are reviewed.

If the copies don't pass the inspection standards listed in the contract, the contractor must re-copy the items at no cost to the park. If the copies pass the testing, the test results are placed with the catalog folder.

See COG 19/13, Preservation Reformatting: Inspection of Copy Photographs.

- **Stamp or mark the copy with the copyright statement** (“For fair use purposes only. No publication,” the word “Copy” and the image negative number.)
- **Re-file the original.**
- **Do a final check for any problems**, such as sensitivities of the subject matter that might cause you to notify the researcher to consult with an affiliated group.
- **Prepare an invoice for any additional or unanticipated charges not already prepaid.** Work with park budget, procurement, or contracting staff to prepare an invoice for any remaining amount due the park for the reprographic services. Also prepare a cover memo describing the fees and the payment methods accepted. This might be a form letter.
- **Arrange for delivery.** Package the copy for delivery. Mail the copy to the researcher along with a copy of the required caption and credit line statements and a copy of the original order. **Note:** At this time, file a copy of the order form in a master file to be kept at least five years for park studies of collection usage.
- **Credit the researcher’s full payment.** Once received, credit any additional amount due for the reproduction services.
- **Document the publication.** Place the publication citations into the ANCS+ catalog record for the items documented. Also keep a follow-up publication file of actual publications using park collections for exhibitions and reference. (**Note:** This list may be generated from ANCS+.)

A list of publications created using park collections is posted on the NPS Museum Management Program (MMP) Publications Page on the World Wide Web at <<http://www.cr.nps.gov/csd>>.

4. *What work don’t I have to do for researchers?*

You don’t have to:

- **undertake any research**, including copyrights or caption research
- **make subjective judgements** about the informational, artifactual, associational, evidential, or monetary values of materials for potential researchers
- **thematically search through collections** to locate specific sorts of items for scholars

Instead, the park determines in the duplication policy what level of support it will provide in response to absentee queries via phone, fax, and e-mail. Generally parks provide phone, fax, and e-mail requests with less support than they provide to scholars who come to the park. Often phone, fax, and e-mail requests receive about 30 minutes support per researcher per month, unless the work has a special status. Special status projects might include a

television documentary, newspaper report, or major scholarly study identified by the park superintendent as receiving special support. Each park must determine what level of support it will provide, when it will provide more, and then stick systematically to this policy. Equality of access is a basic guideline.

Researchers must complete all necessary forms including researcher registration, duplication, and copyright/privacy forms regardless of how their requests were received. (See *MH-II*, Appendix D: Museum Archives and Manuscript Collections, Figures D.14, Researcher Duplication Form, D.15, Copyright and Privacy Restrictions Form, and D.16, Researcher Registration Form.) You will need to mail, fax, or e-mail your forms to those individuals who contact you via these media.

Finally, researchers must pre-pay or provide a monetary deposit for all copies prior to copy production.

5. *What information must the researcher supply on a Researcher Duplication Request Form?*

The researcher should complete the Researcher Duplication Form (see *MH-II*, Appendix D: Museum Archives and Manuscript Collections, Figure D.14). The form incorporates:

- *researcher's contact information*, including full name, address, fax number, and phone number
- *researcher's identification*, including picture identification type and number
- *amount of and type of deposit* to cover duplication costs
- *researcher's institutional affiliation* (employer)
- *date the order was filled*, for order fulfillment tracking purposes
- *who filled the order*, for order fulfillment tracking purposes
- *reason for the copies*, including whether a publication or exhibit is planned
- *description of any special duplication needs*, such as blow-ups, details, or rush order
- *name and catalog number of the collection* from which the item to be duplicated is to be removed or for 3-D objects, the objects specimens name and catalog number as given on the catalog record
- *description of the item to be duplicated*, including catalog or negative number, type of item, process, format, and a description of any subject matter, genre, or other unique identifying characteristics (*Note:* For 3-D objects this would be the object/specimen name).
- *number and type of duplicates wanted*, indicating the size, process, format, color, surface characteristics, and other qualities of the requested duplicate, such as a 8" x 10" glossy black-and-white silver gelatin photographic print on Ilfobrome paper or a 30K TIFF file on a 3.5" diskette.

Note: On this duplication form, the researcher reads and signs a statement that indicates that the use is for non-commercial and non-profit fair use purposes and that the provision of a duplicate doesn't authorize publication or further reproduction. The researcher is also asked to legally indemnify the park from any liability resulting from use of the copies.

6. *How and why do I determine if a use is for-profit or not for-profit?*

Whether a proposed work will be sold is the determining factor. The status of the agency creating the work (a corporation or a non-profit organization) is **not** the factor that determines if a use is for profit. Ask if the items being created (publications, derivative works, etc.) are going to be sold. Ask if admission will be charged if the items are put on exhibit.

If the answer to either question is "yes," then the product is considered for-profit. This for-profit status is important, as the NPS doesn't hold the intellectual property rights, such as copyrights, for all items within its collections. If you authorize a non-fair use, such as public distribution or multiple exhibitions of the same image, you must seek permission in writing from the rights holders. There may be a fee required before rights holders will authorize (license) such a use.

You may provide a limited number of copies of small and insignificant portions of a copyrighted work for purposes of criticism, education, news reporting, parody, and research (which is called fair use). For-profit or sales usages of items for which NPS doesn't hold the copyright aren't legitimate. Nor is widespread distribution of significant portions of an item, such as placing a document on the Web, legitimate. Both the sales usages and the widespread distribution of significant portions of a work are copyright infringements.

To protect the NPS from copyright infringement, don't grant permission to publish works unless:

- the work is in the public domain, *or*
- the park has the copyrights, *or*
- the park or the researcher has received permission from the copyright holders

Note: If the work was produced under an agreement, partnership, by a volunteer, or by a contractor, the partner, cooperating association, volunteer, or contractor holds the copyrights unless there is a specific written agreement that states that the work is a "work for hire" or that the individual gives all copyrights to the park. Remember that the park also requires model release forms, interview release forms, or equivalent permissions from all individuals shown (including interviewees and interviewer), or represented in the materials. For examples of release forms, see *MH-III*, Chapter 3: Publications, particularly Section E.17 and Figures 3.6 and 3.7. ***Even when the publication request meets the above criteria, don't sign forms provided by researchers that state that the park is granting permission to publish. Instead, send the researcher a Permission to Publish Letter (Figure 4.6.). See Chapter 2: Legal Issues.***

7. *How do I handle a permission to publish request?*

Don't sign publishers' and authors' standard permission forms. Instead, send them a notice or letter like that in Figure 4.6, Permission to Publish Letter. The letter makes it clear that the NPS provides copies for fair use purposes only. The NPS may not have the copyrights and other intellectual property permissions necessary to authorize publication. Therefore the researcher is personally responsible for obtaining all permissions and a signed Copyright and Privacy Restriction Statement (*MH-II*, Appendix D, Figure D.15) when in the park.

The letter sent out to the researcher should also indicate:

- that the park can only grant the permission to publish to the extent that it has this right
- whether the individual is granted permission or is not granted permission by checking the appropriate box at the bottom of the form
- precisely which editions and versions of the publication are being authorized (See Chapter 3: Publications, Sections C.5 and C.6 and D.1-D.5.)

Never authorize permission to use NPS materials in all versions of a publication, film, video, or Website in perpetuity.

8. *How do I judge whether a usage is appropriate or not?*

There are a number of questions you want to have answered:

- **Forms:** Did the researcher completely and accurately fill out the researcher registration form, copyright and privacy form, and researcher duplication request? If not, the use isn't appropriate.
- **Type of usage:** Did the researcher indicate whether the use involves:
 - **publishing** the item
 - **exhibiting** in a for-profit environment (exhibits that charge admission or raise a profit for an organization)
 - **distributing** (including placing materials online in multiple viewing stations or on the Web)
 - **performing** (broadcasting, recording, or performing a copyrighted work for a fee or admission charge)
 - **preparing a derivative** work (tee-shirt, poster, or postcard)

To fill these non-fair use requests, the park must have the copyrights **or** the images must be in the public domain either because copyright has lapsed or because the materials didn't qualify for protection (such as federally produced works). If the park doesn't have the copyrights to the work, the publications, derivative works, distribution, and performances aren't appropriate. You must not grant permission for such inappropriate uses. ***If you are aware that a researcher intends an illicit or potentially illegal usage, don't provide a copy.***

- **Duration of usage:** Did the researcher indicate for how many editions and in how many countries the work would be published? If not, and the park has the copyright, go back to the researcher and ask him/her to clarify the usage being requested. Keep permission authorizations as short term as possible—for a single edition if possible. Never agree to grant “all publication rights in perpetuity internationally.” If the park doesn’t have the copyright, don’t give any written or spoken permission to publish, even if the researcher states that “this is a standard form and everyone else fills it out.”
- **Contract researcher concerns:** Is the researcher a contractor who is collecting the duplicates on behalf of someone else? Examples might be picture researchers or contract researchers.

If your researcher is under contract, stress the importance of recording and sharing negative and catalog numbers with the contracting author or publisher. If correct catalog and negative numbers aren’t collected during research, the request will come without this essential information. The museum staff may later be expected to identify and make publication-quality copies for the publisher working only from poor quality xerographic copies with no control numbers. If this scenario does happen, the cost of the extra time required to identify the images should be charged back as part of the order.

If the researcher supplies incorrect data—for example non-existent catalog numbers—don’t undertake significant research on his/her behalf without charging back the costs. Also don’t provide permission to publish until it is clear precisely what is being requested.

9. *How do I decide whether to approve a researcher duplication or publication request?*

When you are deciding whether to approve a standard researcher duplication request, follow the guidance in your park reproduction procedures and in Chapter 1: Evaluating and Documenting Museum Collections Use, and Chapter 2: Legal Issues.

Subject to NPS policy and procedural guidance, approve all scholarly, non-profit educational, and news reporting requests, as well as all those for satire and parody purposes as these purposes are listed as fair use exemptions within the copyright law itself. See Chapter 2: Legal Issues, Section C.10.

These fair use requests are legitimate as long as:

- the request uses only a small or relatively insignificant part of the work, for example, not an entire film but one frame, not an entire photograph but an insignificant detail or portion of an image, not an entire letter but an insignificant paragraph
- the use will not affect the future market for the item and is non-commercial

See Chapter 2: Legal Issues, Section C.9 for further guidance. If the copy usage will result in a for-sale product, wide-spread distribution, or publication, or if the usage utilizes a significant portion of the work or affects the market for the work; or if this is the first publication of a previously unpublished work:

- either the park must have the copyright and be willing to authorize the publication, **or**
- the work must be in the public domain, **or**
- the researcher must have obtained permission to publish from the holder of the original copyright

If the latter is the case, ask for a copy of the copyright holder's permission statement for the park files if you are going to authorize use. In addition, the work must not be legally, ethically, or culturally restricted for any of the reasons described in Section C.1 and Chapter 1. For more guidance, see Chapter 1: Evaluating and Documenting Collections Use, and Chapter 2: Legal Issues.

For non-standard or non-routine requests, such as requests to license a NPS image or to undertake special activities beware of the following:

- ***Incomplete, vague, or incoherent requests for duplicates or publication:***

It is the researchers' responsibility to indicate clearly and cogently what items they would like to have copied, as well as precisely what publication plans they have, if any. The duplicate request form must be filled out, completely and legibly, before the park fills the request.

- ***Publishers "standard" permission forms:***

Many publishers send out "standard" publication permission forms that grant the publisher extensive rights to the copy image. The publisher may indicate that unless the NPS staff signs the form, the publisher won't use the NPS copy. Don't comply. Just because the publisher wants you to use his form doesn't mean you must. Instead, reply with your standard permission form (Figure 4.6, Permission to Publish Letter).

- ***Image morphing or manipulation:***

The Visual Artists Rights Act is a sub-set of the copyright law, which states that no image manipulation is allowed for works produced after 1971 (except for purposes of parody, criticism, and satire) during the term of copyright protection. Therefore, before providing copies and authorizing publication involving visual image manipulation, you should determine whether the image is still protected by copyright.

If the visual image is protected by copyright, don't authorize multiple exhibitions, or any publications or products involving manipulation of the visual image in the copy. **Note:** Images produced by federal employees are not protected by copyright. For contract work, the copyright status depends upon what the contract states. See Chapter 2: Legal Issues.

- ***Requests for permission in perpetuity or internationally:***

You want the park to be able to retain some control over usages of park collections to:

- *protect your park from potential liability* from copyright, libel, privacy, publicity, and similar legal problems
- *generate allowable cost-recovery revenue* from park collections to help make park collections more self-sufficient
- *ensure that proposed future usages are not culturally or ethically insensitive* (If they are sensitive, alert the publisher to the problem and explore solutions. See Chapter 1: Evaluating and Documenting Museum Collections Use.)
- *ensure that proposed future usages meet current NPS policy* (See Section C.1)

Limit all permissions to publish by a time limit. Some publishers will request “all rights in perpetuity internationally,” rights for “all editions,” or “all rights overtime throughout the galaxy.” Don’t agree to any of those requests. Instead, grant rights for a single edition or two or for all editions published prior to a given date—perhaps for the next five years. The edition may be international, but shouldn’t be “in perpetuity” or “galaxywide.” When you limit your permissions, the publisher can always come back to you again later to request permissions for additional editions.

- ***Exclusive usage:***

Some publishers and researchers will request exclusive usage or publication of some items. This is particularly likely to happen with groups requesting 2-D reproductions for use on online order fulfillment services (which post images on the Web and then sell 2-D reproductions or high quality digital files to interested parties).

The NPS may NOT offer exclusive usage of federal collections to anyone.

- ***Incorrect or insensitive usage:***

On occasion you may receive a request to publish a NPS copy in a publication that you feel contains incorrect, culturally insensitive, or otherwise troublesome content. As public servants, NPS staff should not censor publications. Instead we must support freedom of speech. That said, however, NPS collections shouldn’t be exhibited, performed, published, or used in products in ways counter to the law, professional ethics, or NPS management policy. The ultimate decision rests with your superintendent.

10. *When might I refuse to grant permission to publish?*

There are several situations in which you might appropriately deny permission to publish or place multiple copies of an object on exhibition or use them in a product such as a poster. These include instances when publishing, exhibiting, distributing, or preparing a derivative work from the proposed image is:

- ***illegal***, such as when the copyright is held by someone other than the NPS and the researcher has not obtained permission; or the caption contains protected archeological site location information (See Chapter 2: Legal Issues for further guidance.)
- ***against NPS management policy***, such as when the caption contains protected or legally restricted information or when reproduction will cause significant damage to the original object or a protected resource (See Chapter 1: Evaluating and Documenting Museum Collections Use, Section C, Management Issues.)
- ***against professional ethics***, such as publishing information on a NPS museum object that is substantially incorrect or untrue or that might contain racial, sexual, or similar slurs or misleading or incorrect information about a living private individual (See Chapter 1: Evaluating and Documenting Museum Collections Use, Section D, Ethical Issues, and Section E, Cultural Issues.)

If specific questions arise, talk to your regional/SO curator and the NPS or DOI solicitor.

11. *Must researchers fill out NPS Special Use Permits to publish a NPS image?*

No. Researchers should instead fill out the Researcher Registration Form, Researcher Duplication Form, Copyright and Privacy Restrictions Form, and pay for their requested copies. A special use permit is not required to publish, exhibit, or research NPS collections. Do, however, keep a copy file of all publication permissions you grant for documentation purposes.

The park superintendent may require that any bulk copying or commercial agreement be formalized via the use of a special use permit. Keep one copy of permissions in the item's accession or catalog folder.

12. *What are the appropriate caption and credit line policies?*

The Access Policies and Rules Governing Use Statement in *MH-II*, Appendix D: Museum Archives and Manuscript Collections, Figure D.13a-b, indicates the proper credit line and caption format for use by publishers, researchers, and staff for archival materials. The caption and credit line statement in Chapter 3: Publications, Section E.18, indicates the proper format for 3-D items. Use this combined caption and citation format to indicate the nature and source of material to be published, whether in an article, book, catalog, or on the Web.

The recommended components of a proper citation are:

- item title in quotes followed by object name or collection title
- brief description (including process, format, materials, and measurements)
- date(s)

- plate, page, or image number in the text
- name of the object creator
- photographer, if appropriate
- park name
- item or collection catalog number
- negative number, if appropriate
- donor, if applicable

For example:

Western Mono Cooking Basket
 ca. 1910-1920
 Collected by Ansel F. Hall at the 1921 Indian Field Days
 Sedge root, bracken fern root, bunchgrass. H 6 1/2", Dia. 14"
 YOSE-133
 Gift of Mrs. William Moyle DuVal

Plate 97, Keystone View Company, "Yellowstone National Park" shows an appreciative crowd of Hardy Hotel waitresses in full costume gathered around Old Faithful ca. 1918. Wapantucket Collection, YELL 123, Negative # 98977.

Refer to Chapter 3: Publications, Section E.18. **Note:** The order of the elements within the caption is flexible, depending upon the use.

Publishers and authors don't always follow correct citation procedures. You may request a chance to review text and captions for accuracy before publication. Encouraging researchers and publishers to be specific and accurate will save you time and effort later when you must fill future reproduction requests generated by these publications.

13. *Can I charge money for permission to publish a NPS item?*

No. You can't charge money to publish., You can charge back the cost of your work, however, for cost-recovery purposes in accordance with 43 USC 1460, including:

- time spent on research, whether you grant the permission or not
- correspondence with those seeking permission to publish

You may also charge fees for commercial filming and photography of collections. See Section B.5. You might wish to determine the average cost of doing this work. Future charge backs might be done at this average rate in order to save time and money. See Sections C.2 and C.3.

14. *How do I handle cost-recovery money received from duplication work?*

You should handle cost-recovery fees by transferring them to an appropriate park account with the assistance of park fiscal, procurement, or contracting officers. The account must be used in the future to furnish copies.

15. *What special needs might the researcher indicate?*

The researcher might ask for any or all of the following:

- ***rush orders*** (*Note:* Check with your laboratory first before accepting rush orders.)
- ***copies that are details of portions of originals*** rather than complete 1:1 copies (*Note:* 1:1 means that the copy is an exact model of the original. The copy matches the original's dimensions exactly.)
- ***copies that have a perfect scale match*** to the original 1:1, such as exact scale engineering drawings
- ***enlarged copies of originals***
- ***copies made under special lighting***, such as under raking or infrared lighting for examination purposes
- ***copies made against special backgrounds***, such as back-lit transparencies being rephotographed
- ***copies made under special conditions***, such as an object being photographed against a blue background or the image made using a special filter
- ***manipulated copies***, with darkroom modifications such as airbrushing, dodging and burning, and retouching, or post print manipulation such as retouching or hand-tinting, as well as with digital manipulation such as morphed images. See *MH-I*, Appendix R: Care of Photographic Collections, for details
- ***rights to shoot scenery, museum objects, or exhibitions for commercial purposes*** (in which case a special use permit is necessary if the work is commercial filming and may be necessary for commercial photography)
- ***toned copies made to enhance their longevity***, for example photographs or microfilm with polysulfide toning
- ***unusual formats of copies***, such as making card jackets or microfiche from roll microfilm masters

When possible, accommodate these requests. Your photographer or contractor should be able to handle most of these special requirements. Remember to inquire about these special requirements when you are contracting.

16. *How do I identify the impacts on the collection?*

The major impacts on the collection are usually the result of:

- ***Handling damage:*** Ensure that all copy staff working with the originals understand how to handle original museum materials. See *MH-I*, Chapter 6: Handling, Packing and Shipping Museum Objects. Also see *COG* leaflets 19/4, Archives: Preservation Through Photocopying; 19/7, Archives: Reference Photocopying; 19/8, Preservation of Magnetic Media, 19/17; Handling Archival Paper-Based Materials; 19/19, Care of Archival Compact Discs; and 19/20, Care of Archival Digital and Magnetic Media.

- **Shipping damage:** See *MH-I*, Chapter 6: Handling, Packing and Shipping Museum Objects, and *COG* 14/8, Caring for Cellulose Nitrate Film.
- **High intensity or long duration light exposure:** See *MH-I*, Chapter 4: Museum Collections Environment, Section E, Light, and the appendices for the specific type(s) of material you are dealing with, such as Appendix J: Curatorial Care of Paper Objects; Appendix M: Management of Cellulose Nitrate and Ester Film; Appendix R: Curatorial Care of Photographic Collections.
- **Environmental stresses** caused by wide fluctuations in temperature and relative humidity. See *MH-I*, Chapter 4: Museum Collections Environment.
- **Usage of automatic feed copying equipment** such as force-feed xerographic copy machines, step-and-repeat microfilm cameras, and form-feed scanners.

17. *What steps do I take to prevent collections from being damaged?*

There are a number of simple steps you can take:

- **Prepare a Park Museum and Archival Access and Usage Policy**
- **Train** your staff and contractors thoroughly.
- **Inspect** how the work is being done on a regular basis by making surprise visits to the copy site.
- **Establish quality control procedures** to check and test the resulting copy product carefully.
- **Monitor** the condition of returned original items. If a change in condition is noted, inquire at the laboratory. Register your concern and ask how the problem may have occurred, for example, the photographic fading is most likely due to overexposure to light or too intensive a light exposure.
- **Contract effectively** by ensuring that any contracts or job descriptions written for copy work include quality control evaluation criteria, a requirement to meet national standards, and clear statements about how the work is to be done and what constitutes unacceptable performance.

18. *How do I inspect copies once they have been returned?*

When the copies are back from the reproducing firm or park copy office, follow the guidance listed in Section C.3, within your contract specifications, and in the various *COG* leaflets cited in Section A.10.

D. Glossary:

Aperture Card is a punch card (stiff board computer data processing system card) with holes that contain micrographic images.

Bordering refers to identifying the non-textual or image frame or margin area around a source document so that markings in the margins or frame are not captured.

Cartridge is a cassette of magnetic tape (audiotape, videotape, or electronic record) or microfilm that is in an enclosed container. Cartridges are loaded and unloaded into playback devices, such as a microfilm reader or tape player.

Cassettes are containers holding audiotape, videotape, microfilm, or motion picture film on a spool with an internal take-up spool to contain the film or tape once played. The entire package is enclosed and protected from mishandling.

CD-ROM refers to Compact Disc Read-Only Memory, which are magnetic media storage devices requiring hardware and software for access. CD-ROMs are produced as flat discs made out of a variety of non-archival media generally lasting 5-30 years. When selecting CDs for storage, select CDs with a scratch resistant lacquer, a gold reflector layer, thalocyanine dyes, and a stable substrate. Avoid all CDs or DVDs with cyanine dyes and aluminum reflection layers, or those requiring proprietary software or file formats. See *COG 19/19, Care of Archival Compact Discs*.

Cellulose ester film includes the three most common forms of late 20th century motion picture and still photographic negatives after cellulose nitrate. While not a safety hazard, acetate, diacetate, and triacetate films self-destruct rapidly over time. Most modern color film, including slides made today, are cellulose ester. See *MH-I, Appendix M: Management of Cellulose Nitrate and Ester Film*.

Cellulose nitrate film is the most common form of 20th century motion picture (popular from around 1890-1950) and still photographic negative and X-ray film. It is a health and safety hazard and requires rapid copying and cold storage. See *MH-I, Appendix M: Management of Cellulose Nitrate and Ester Film*.

Centering refers to placing a source document or the image of a document in the center of the field of vision or copy document.

Color correction refers to the process of changing color in a copy to more closely match that in the source document. This should be done systematically and should be documented in all metadata.

Color management refers to a systematic attempt to maintain color balance in copies that are equivalent to those in the original source document by calibrating and managing all equipment (including monitors, scanners, and original lighting), software, and processes to maximize accuracy.

Computer Output Microfilm (COM) is a method of printing electronic data directly from a database or other electronic source onto microfilm. This is a “hybrid approach” to reprographics that uses digital media for access and microfilm for preservation to circumvent the short useful lifetime of microfilm and the awkward access methods of microfilm.

Compression is the process of forcing more electronic data into less space to speed processing, storage, and transmission. This is a digital process. See also *Lossy compression* and *Lossless compression*.

Copies are non-original (second generation) reproductions made from first generation or master negatives, digital files, or other sources. Copies include copy prints made from master negatives, derivative files made from master digital files, and microfilm distribution copies made from master microfilm negatives. Second generation prints of record photographs or photographic negatives or prints made from original negatives or prints may also be called copies.

Decompression is the process of inflating compressed digital data and attempting to retrieve the original data unchanged. See also **Lossless compression** and **Lossy compression**.

Derivatives are digital (electronic) files made from other digital files often in a different size or for a special purpose. These digital derivatives may be thumbnails (very small files) or derivatives made for special usages, such as the Web. Derivatives are sometimes referred to as digital surrogates.

Diazo film is a form of non-archival quality microfilm in which the image is produced by the effect of light upon diazonium.

Digital cameras magnetically capture digital images from source documents or objects.

Digital surrogates. See **Surrogates**.

DPI refers to dots per inch, the indication of the resolution of a scanned image.

Duplicates are two identical copies of the same generation. The original creator of the item may create two identical originals at the same time on the same equipment using the same materials. For example: the same photographer may take two identical images of the same subject matter on the same roll of film using the same camera at the same time and place. While the two images are snapped only seconds apart and appear identical, they have different frame numbers and purposes and are said to be duplicates of each other. The first photograph is the preservation master, the second the usage copy. If the duplicates are letters, they should both have original signatures. In this example, both images are originals as they are both first generation and identical to each other for most practical purposes. A duplicate is the only “copy” process that may be first generation. **Note:** Most people now use the word “duplicate” interchangeably with the word “copy.”

Duplication master is a copy of an item used to produce future copies, such as a negative.

Dynamic range is the color or bit depth in a digital file listed in bits to indicate the number of colors represented. For example, 8-bit images allow up to 265 colors; 24-bit images can represent 16 million colors, and so forth.

Electrostatic process is a dry direct copy process that uses plain paper (hopefully acid-free) and a copy machine that utilizes an electrically photo conductive process.

Enlargement is a blow-up of a copy made larger than the original. This term is also used to refer to the interpositive (transparency) used to make the reproduction.

Facsimiles are copies of the content of an item usually made as close to identical as possible to the original often using the same media, process, appearance, and often the same format as the original. Facsimiles are almost always produced later by someone other than the creator of the original. When the word “facsimile” is preceded by a process name, such as “photographic facsimile” you are being notified that the facsimile is NOT in the same process or format as the original. Therefore the facsimile *is* a close-to-identical copy in that process or format. **Note:** This usage should be distinguished from that of “fax” a copy image of a document sent electronically to a different locale.

Fair copy refers to a complete and exact copy of the final version of a document.

Fax is a copy image of a document sent electronically to a different locale.

Fiche. See **Microfiche**.

Film is a transparent and flexible sheet of plastic or gelatin that may contain images or magnetic particles.

Floppy disk is a flat sheet of magnetic film in the shape of a disk that is held within a stiff cover.

GIF refers to graphic image file, a widely used proprietary digital file format owned by CompuServe.

Gray scale refers to the number of shades of gray in an image that can be identified and copied.

Hard disk is a computer hardware storage device for containing data.

Header refers to metadata in a scanned image containing file size, name, and source that is placed with the image file and the label on a piece of microfiche.

Image enhancement is the process of using a darkroom, xerographic copier, or digital scanner and editing software to change, modify, edit, or alter an image.

Image is a broad term used to refer to either an original visual document, such as a photograph, drawing, or painting; or a copy of an original document.

Imaging is the process of digital or photographic capture of a document, drawing, or photograph.

JPEG is a digital file format proposed by the Joint Photographic Experts Group and supported by the International Standards Organization for compression and storage of still images. This widely used format may be lossy.

Lossless compression is a digital file reduction process that cuts the file size without causing a change in the file's appearance (once uncompressed) or any loss of data. Lossless compression doesn't generally compress files as much as lossy compression. TIFF files can be a lossless compression format.

Lossy compression drops "inessential" information from a digital file, so that the amount of storage space needed for the file can be limited. Lossy compression reduces file size more than lossless compression; however when uncompressed, the file quality and appearance will have changed somewhat due to the amount of information discarded. The amount of file change may lead to "unintended visual affects" such as "compression artifacts" that may be patterns or marks in the copy that aren't in the original. On occasion, the visual changes may be relatively imperceptible. GIF and JPEG files are lossy compression file formats.

Magnetic media includes audiotape, videotape, and electronic records that have been captured as magnetized particles on the surface of a tape or other media.

Magnetic tape is a format of plastic tape coated with an electromagnetic layer that can hold audiotape recordings, video recordings, and electronic records.

Masters are original first generation images.

Metadata is "information about data and data systems." In plain English, metadata refers to digital or magnetic descriptions of file sizes, contents, and formats; database system contents, location data, characteristics, usage guidance, or similar instructions. Metadata is commonly created to facilitate access and usage of the files and their data and may become a part of the file, such as a file header.

Microfiche is a thin rectangular sheet of clear film that contains a number of microfilm images in horizontal rows, like cartoon strips and in columns. Also called "fiche" these microfiche, often have an eye-legible label or heading on their top.

Microfilm is a very sensitive form of photographic film capable of capturing very small and detailed images of materials in a variety of film processes, including silver gelatin (also called silver halide), diazo film, and vesicular film. The latter two processes are used for distribution or usage copies and aren't considered archival (permanent and durable).

Micrographics is the process of producing microfilm copies of original materials.

Migrate is the process of moving digital data into file formats compatible with new software and hardware. Software changes every 18 months to 5 years. All electronic data should be moved to the latest edition of software and hardware compatible formats at least that often in order to remain usable. Many software packages are not “backwardly compatible,” that is capable of playing or using older files produced on earlier versions of the same software. When a software package or file format is proprietary, the problem is compounded because fewer contractors can support the migration. Materials in proprietary formats may require rescanning rather than migration. See also **Refreshing**.

Negative is the master photographic image produced by most cameras and used to produce photographic prints. Negatives have reversed tonalities from positive images; that is, the light areas in a print are dark in a negative. In a colored negative the colors are reversed to complementary tonal values.

Open reel tape. See **Reel-to-reel tape**.

Original is the source document or object that is to be copied.

Photo CD or photo Compact Disc is a proprietary Kodak file format that produces five different sizes of digital files of each image stored on a single compact disc. This is not a long-lived archival storage media. Finally this form is proprietary meaning that only a single vendor supports it. When the software and hardware and processing infrastructure are no longer being supported by this vendor, it will be challenging to migrate this captured information to the next generation of file formats, software, and hardware.

Pixel is a digital picture element or a tonal value in binary code.

Polarity refers to the reversal of tones found in a photographic negative so that light areas in the print become dark areas in the negative and vice versa.

Quality control is the process of checking copies against standards produced by the American National Standards Institute (ANSI) and the Association of Information and Image Management (AIIM) and other organizations, including completeness, density, labeling or indexing, resolution, and residual chemicals for photographs and microfilm.

Reader is an optical enlarging and playback device for viewing microfilm.

Reader-Printer is an optical enlarging and playback device for viewing and making xerographic copies of microfilm.

Reduction ratio is the scale of the shrinkage of a microfilm when compared to the original source document, for example, 12X refers to a 12:1 ratio. 12:1 tells you that the linear dimension of the document is 12 times smaller in the microfilm.

Reel is an open spool for containing microfilm, motion picture, film, or magnetic tape that has at least two flanges.

Reel-to-reel tape is magnetic (audiotape, videotape, or electronic) tape on an open spool without the protective casing that characterizes cassettes and cartridges. Reel-to-reel tape should be stored on hubs (unflanged spools) in stable film cans.

Refreshing refers to the process of rewinding and forming a smooth “tape pack” that ensures that no stresses are placed on any particular section of a tape. Also occasionally used to refer to the process of copying a tape. See also **Migrate**.

Reprographics is the focus of this chapter. It includes all copy and duplication processes including photography, motion picture film duplication, micrographics, and xerography. Some authors also include digital scanning, audiotape copying, and videotape copying.

Reproduction is an exact copy of a source document in content, although the size, process, and context may be quite different.

Resolution refers to the sharpness of detail or focus of an image expressed as a numeric value, either as lines per millimeter discernible in a standard test pattern image or for digital files as the numbers of pixels listed as height x width in pixels or dots per inch (dpi), for example 50 x 100 dots per inch.

RGB refers to the system of additive color creation used in video display devices and some photographic processes.

Scanner is a piece of hardware that captures an electronic image of a source document for access purposes.

Silver gelatin film is an archival form of photographic film, motion picture film, and microfilm created by the action of light on silver halide particles within a gelatin emulsion.

Silver halide film. See *Silver gelatin film*.

Sound recordings include any base or medium that contains captured sound whether a wire recording, magnetic recording, phonograph recording, wax recording, or filament recording.

Surrogates are copies that take the place of an original for a specific purpose, such as preservation, deposit at another institution, or for other purposes noted under Section A.2

Threshold is the bitonal digital scanning setting at which gray is read as either black or as white.

TIFF or tagged image/interchange file format is a lossless digital file format that is widely used as an industry standard and often selected as the best format for digital master files.

True color generally is used to describe 24-bit color scanning that can represent 16 million colors. See *Dynamic range*.

Vesicular film is a form of non-archival microfilm in which bubbles form an image that is made somewhat more durable by heating and cooling. This process has a much shorter life expectancy than silver gelatin films.

Videodisc is a laser-etched optical disc used for storing sound and moving images. Although non-magnetic, this process is dependent upon having a working playback device.

Videotape is a magnetic recording media for moving images that is not archival as it is relatively short-lived and not durable. The only truly long-lived moving images are motion picture film on polyester film bases.

Watermark: A watermark is a visible or invisible encoding pattern (in an electronic file) or arrangement of paper fibers (in a non-magnetic paper document) that indicates the origins or physical ownership of the electronic item (for digital files) or the material used in making the item (for paper documents). Not all digital watermarking packages work precisely the same. Some watermark software simply marks a document. Other watermarking software packages allow the watermarked item to be directly linked to a Web page that provides source information, as well as allowing the watermark owner to search the Internet for all occurrences of the watermarked item on the Web.

E. Selected Bibliography

Digital Media:

- Agfa. *An Introduction to Digital Scanning*. Mt. Prospect, Ill.: Agfa Pre-press Education Resources, 1998.
- Besser, Howard. "Adding an Image Database to an Existing Library and Computer Environment: Design and Technical Considerations," *ASIS 1991 Midyear Proceedings: Multimedia Information Systems*, 1992.
- _____. "Image Databases," *Encyclopedia of Library and Information Sciences* 53:16, New York: Marcel Dekker, 1994, 1-15.
- Besser, Howard and Jennifer Trant. *Introduction to Imaging*. Santa Monica, Calif.: Getty Art History Information Program, 1995.
- Conway, Paul. *Conversion of Microfilm to Digital Imagery: A Demonstration Project*. New Haven, Conn.: Yale University Library, 1996.
- Donovan, Kevin. "The Anatomy of an Imaging Project: A Primer for Museums, Libraries, Archives, and Other Visual Collections." *Spectra* 23:2. Laguna Beach, Calif.: Museum Computer Network (Winter 1995/1996) 19-22.
- Elkington, Nancy E. *Digital Imaging for Libraries & Archives*. Mountain View, Calif.: Research Libraries Group, Inc., 1994.
- _____. *Digital Imaging Technology for Preservation: An RLG Symposium*. Mountain View, Calif.: Research Libraries Group, Inc., 1994.
- Ester, Michael. *Digital Image Collections: Issues and Practice*. Washington, D.C.: The Commission on Preservation and Access, 1996.
- Fleischhauer, Carl. *Frameworks and Finding Aids: Organizing Digital Archival Collections*. Washington, D.C.: Library of Congress, October 1994. Also available at <<http://memory.loc.gov/ammem/ftpfiles.html>>.
- Gaynor, Edward. "From MARC to Markup: SGML and Online Library Systems" in From Catalog to Gateway, Briefings from the CFFC, No. 7, 1996, a supplement to *ALCTS Newsletter* 7, 2: A-D (1996). **Note:** ALCTS is the Association for Library Collections & Technical Services.
- Image Permanence Institute. *Recommendations for the Evaluation of Digital Images Produced from Photographic, Micrographic, and Various Paper Formats*. Rochester, N.Y.: Image Permanence Institute for the Library of Congress, May 1996. Also available at <<http://memory.loc.gov/ammem/ftpfiles.html>>.
- Kenney, Anne, and Stephen Chapman. *Digital Imaging for Libraries and Archives*. Ithaca, N.Y.: Cornell University, 1996.
- Kenney, Anne, and Oya Rieger. *Using Kodak Photo CD Technology for Preservation and Access*. Ithaca, N.Y.: Cornell University Library and New York State Department Program for the Conservation and Preservation of Library Materials, 1998.
- Library of Congress. *Access Aids and Interoperability*. Washington D.C.: Library of Congress, 1996. Also available at <<http://memory.loc.gov/ammem/ftpfiles.html>>.

- _____. *Digital Formats for Content Reproductions*. Washington D.C.: Library of Congress, 1998. Also available at <<http://memory.loc.gov/ammem/ftpfiles.html>>.
- _____. *Reproduction Quality Issues in a Digital Library System*. Washington D.C.: Library of Congress, 1992. Also available at <<http://memory.loc.gov/ammem/ftpfiles.html>>.
- _____. *Digital Historical Collections: Types, Elements, and Construction*. Washington D.C.: Library of Congress, 1996. Also available at <<http://memory.loc.gov/ammem/ftpfiles.html>>.
- _____. *Final Report of the American Memory User Evaluation*. Washington D.C.: Library of Congress, 1993. Also available at <<http://memory.loc.gov/ammem/ftpfiles.html>>.
- _____. *Proceedings of the Workshop on Electronic Texts*. Washington D.C.: Library of Congress, June 1992. Also available at <<http://memory.loc.gov/ammem/ftpfiles.html>>.
- _____. *Requests Proposals for Digital Images from Original Documents, Text Conversion and SGML-Encoding National Digital Library Program (RFP96-18)*. Washington D.C.: Contracts and Logistics Services, 1996.
- _____. *Requests Proposals for Digital Images of Pictorial materials: National Digital Library Program (RFP97-9)*. Washington D.C.: Contracts and Logistics Services, 1996.
- Lu, Kathleen. "Technological Challenges to Artists' Rights in the Age of Multimedia: The Future Role of Moral Rights," *Reference Services Review* 22, 1 (1994): 1-10.
- Ostrow, Stephen. *Digitizing Historical Pictorial Collections for the Internet*. Washington, D.C.: Council on Library and Information Resources, 1998.
- Puglia, Steven. *Creating Permanent, Durable Information*. Washington, D.C.: National Archives and Records Administration, 1998.
- _____. *NARA Guidelines for Digitizing Archival Materials for Electronic Access*. Washington, D.C.: National Archives and Records Administration, January 1998.
- _____. *U.S. National Archives and Records Administration Electronic Access Project Scanning and File Format Matrix*. Washington, D.C.: National Archives and Records Administration, 1997.
- Reilly, James M. *Technical Choices in Digital Imaging: The Technical Images Test Project in Review*. Presented at the Society of American Archivists Annual Conference in Indianapolis, Ind., September, 1994 and in Mountain View, Calif., at the Image Access Project of Research Libraries Group in 1995.
- Research Libraries Group. *Managing Digital Imaging Project: An RLG Workshop*. Mountain View, Calif.: Research Libraries Group, 1997.
- _____. *Selecting Library & Archive Collections for Digital Reformatting: An RLG Symposium*. Mountain View, Calif.: Research Libraries Group, 1997.
- Weinstein, William. "Designing an Image Database: A Holistic Approach." *Visual Resources* 10:1 (1994): 49-56.

Web-based Digital Data Information Sites:

ALA-SAA Joint Statement on Access: Guidelines for Access to Original Research Materials:
<http://www.archivists.org/governance/handbook/app_k12.htm>.

Archivists Warn: Don't Depend on Digital Tape: <http://www.connact.com/~eaw/minidisc/dat_archiving.html>.

Association of Information and Image Management: <<http://www.aiim.org>>.

Challenge of Archiving Digital Information: <<http://www.rlg.org/ArchTF/chaleng.html>>.

Commission on Preservation and Access: <<http://www.clir.org/cpa>>.

D-Lib Magazine (a monthly magazine on what's new in digital archives and library work): <<http://www.dlib.org/>>

Future Directions in Access and Preservation Technologies and New Electronic Formats:
<<http://www.nla.gov.au/nla/staffpaper/cwebb3.html>>.

Infomedia Project of Carnegie Mellon University: <<http://www.informedia.cs.cmu.edu/>>.

Library of Congress technical information and background papers: <<http://memory.loc.gov/ammem/ftpfiles.html>>.

National Archives and Records Administration (NARA) Center for Electronic Records: <<http://www.nara.gov/nara/electronic>>.

NARA Electronic Access Project Scanning and File Format Matrix : <<http://www.nara.gov/nara/vision/eap/eapspec.html>>.

NARA Guidelines for Digitizing Archival Materials for Electronic Access: <<http://www.nara.gov/nara/vision/eap/eapspec.html>>.

National Media Laboratory: <<http://www.nml.org/MediaStability>>.

Preserving Access to Digital Information: <<http://www.nla.gov.au/padi>>

Preserving Digital Information: <<http://www.rlg.org/ArchTF/TFADI/index.htm>>.

Preserving the Internet: <<http://www.sciam.com/0397issue/>>.

Research Library Group Preservation Program: <<http://www.rlg.org/preserv>>.

Society of American Archivists Statement on Copyright, Archival Institutions and the Digital Environment:
<http://www.archivists.org/governance/handbook/app_K5.htm>.

Society of American Archivists Statement on the Preservation of Digitized Reproductions:
<http://www.archivists.org/governance/handbook/app_K6.htm>.

UC Berkeley Digital Library Project: <<http://elib.cs.berkeley.edu/>>.

Universal Preservation Format: <<http://info.wgbh.org/upf/>>.

Microfilm:

Note: American National Standards Institute (ANSI) standards are available from 1430 Broadway New York, NY, 10018; while Association for Information and Image Management (AIIM) standards are available from 1100 Wayne Ave, Silver Spring, MD, 20910:

AIIM. TR11 (*Microfilm Jacket Formatting and Loading Techniques*)

ANSI/AIIM MS5-1992 (*Microfiche*)

ANSI/AIIM MS 23-1991 (*Operation, Inspection, and Quality Control Procedures for First-Generation, Silver Gelatin Microfilm*)

ANSI/AIIM MS14-1988 (*16mm and 35mm Formats for Roll Microfilm*)

ANSI/AIIM MS19-1987 (*Microform Identification*)
ANSI/AIIM MS23-1991 (*Roll Microfilm Inspection*)
ANSI/AIIM MS34-1990 (*Reels for Roll Microfilm*)
ANSI/AIIM MS43-1988 (*Copy Microform Inspection*)
ANSI/AIIM MS45-1990 (*Microform Inspection for Deterioration*)
ANSI/AIIM MS51-1991 (*Micrographics Resolution*)
ANSI/AIIM PH1.43-1985 (*Micrographic Storage*)
ANSI/AIIM PH1.53-1984 (*Micrographic Storage*)
ANSI/ASC PH4.8-1985 (*Finding and Measuring Residual Photographic Chemicals, particularly Thiosulfate*)
ANSI/ASC PH1.4-1984 (*Silver Gelatin on Polyester Film Photography of Archival Records*)
ANSI/NFPA 232, (*Protection of Records*)
ANSI/NFPA A 232M (*Archives and Records Centers Protection Techniques*)
ANSI/NFPA 910 (*Library Protection Techniques*)
ANSI/NFPA 72E, (*Automatic Fire Detectors*)
ANSI PH 1.43-1985 (*Storage of Processed Safety Film*)
ANSI PH 1.43-1983 (*Storage of Processed Safety Film*)
ANSI PH 5.6-1974 (*Dimensions for 100-Foot Reels for Processed 16mm and 35mm Microfilm*)
ANSI Z39.62 (*Microfiche Heading Information*)

Eastman Kodak. *Storage and Preservation of Microfilms, Kodak Publication D-3*. Rochester, N.Y.: Eastman Kodak Company, 1996.

Elkington, Nancy, ed. *RLG Archives Microfilming Manual*. Mountain View, Calif.: Research Libraries Group, 1994.

_____. *RLG Preservation Microfilming, Handbook*. Mountain View, Calif.: 1992.

Gwin, Nancy E. *Preservation Microfilming: A Guide for Librarians and Archivists*. Chicago: American Library Association, 1987.

Library of Congress. *Specifications for the Microfilming of Books and Pamphlets in the Library of Congress*, Silver Spring, MD: National Micrographics Association, 1983.

Waters, Donald J. *From Microfilm to Digital Imagery*. Washington, D.C.: Commission on Preservation and Access, 1991.

Photographs:

American National Standards Institute (ANSI) Standards:

ANSI IT9.5.1996/ISO8225, Ammonia-Processed Diazo Photographic Films
ANSI IT9.12.1995/ISO 9718, Processed Vesicular Photographic Film
ANSI IT9.1994, Thermally Processed Silver Microfilm
ANSI IT9.91996, Stability of Color Photographic Images-Methods for Measuring
ANSI IT9.21.1996, Life Expectancy of Compact Discs (CD-ROM)-Methods for Estimating
ANSI PIMA IT9.26, Life Expectancy of Magneto-Optic (MO) Disks
ANSI PIMA IT9.27, Life Expectancy of Information Stored in Recordable Compact Disc Systems

Eastman Kodak. *Copying and Duplicating: Photographic and Digital Imaging Techniques*. Rochester, N.Y.: Kodak Publication M-1, CAT No. E152- 7969.

Northeast Document Conservation Center (NEDCC). *Technical Leaflet. Reformatting: Duplication of Historical Negatives*. Andover, Mass.: NEDCC, 1994.

NEDCC. *Technical Leaflet. Photographic Materials: A Short Guide to Nitrate Negatives: History, Care, and Duplication*. Andover, Mass.: NEDCC, 1994.

_____ and the National Park Service. *Afterimages: Reformatting Visual Materials in a Digital World*. Andover, Mass.: NEDCC, 1998 (200+ page conference proceedings sent to each regional curator).

Puglia, Steve. *The Copying of Oversized Materials*. College Park, Md.: National Archives and Records Administration, March 1993, revised 1998.

_____. "Duplication Options for Deteriorating Photo Collections," in *Photograph Preservation and the Research Library*. Mountain View, Calif.: The Research Libraries Group, 1991.

_____. *The Preservation of Acetate Film Materials: A Cost/Benefit Analysis for Duplication and Cool/Cold Storage*. College Park, Md.: National Archives and Records Administration, 1998.

Robb, Andrew, and Monique C. Fischer. *Guidelines for Care & Identification of Film-Base Photographic Materials*. Winterthur, Del.: University of Delaware Winterthur Museum, 1993.

Sound and Video Recordings:

Association for Recorded Sound Collections. Associated Audio Archives Committee. *Audio Preservation: A Planning Study*. Silver Spring, Md.: Association for Recorded Sound Collections, 1987.

Bertram, H.N., and A. Eshel. *Recording Media Archival Attributes (Magnetic)*. Redwood City, Calif.: Ampex Corporation, 1979.

Calmes, Alan. "New Preservation Concern: Video Recordings." *Commission on Preservation and Access Newsletter*, 22 (April 1990). Washington, D.C.: Commission on Preservation and Access, 1990.

Committee on Preservation of Historical Records. *Preservation of Historic Records: Magnetic Recording Media*. Washington, D.C.: National Academy Press, 1986.

Ward, Alan. *A Manual of Sound Archive Administration*. Trowbridge, Wiltsire, Great Britain: Gower Publishing Company, 1990.

Xerographic Copies:

ANSI/NISO Z39.48.1992, Permanence of Paper for Publications and Documents in Libraries and Archives.

NARA Bulletin No. 95-7.

Joint Committee on Printing A270
ISO 9706
ISO 11108

F. List of Figures

Figure 4.1.	How to Select an Appropriate Process or Format of Reproduction for each Reproduction Purpose or Function	4:69
Figure 4.2.	Reproduction Order Notification Sheet.....	4:70
Figure 4.3.	Comparison of the Advantages and Disadvantages of 2-D Copy Formats4: (Sample)	4:71
Figure 4.4.	2-D Reproductions Cost Recovery Chart for Estimating Time Spent (Sample)	4:76
Figure 4.5.	Cost-recovery Fees Formula (Sample).....	4:77
Figure 4.6.	Permission to Publish Letter (Sample).....	4:78
Figure 4.7.	Wording to be Included in a 2-D Independent Contractor Agreement (Sample)	4:79

Figure 4.1. How to Select an Appropriate Process or Format of Reproduction for each Reproduction Purpose or Function (*Note:* This chart focuses on visual and textual documents rather than sound, moving images, or magnetic media. For guidance on museum object photography, see *MH-II*, Appendix L: Photography. For guidance on magnetic media, etc., see the *Conserve O Grams* series.)

Purpose or Function of the Copy	Process/Format of Reproduction to be Produced
<ul style="list-style-type: none"> • Duplication Masters • Preservation Masters • Condition Copy • Deposit Copy • Record Copy • Security Copy • Treatment Copy 	<ul style="list-style-type: none"> • Duplication Master: Produce a 4" x 5" master copy photographic still negative or larger to serve as your park's duplication master. • Preservation Master: Produce a 4" x 5" preservation transparency (that can later be used to produce new negatives) as your park's preservation master. • Usage Copies: Produce 8" x 10" print(s) for park usage, such as for: <ul style="list-style-type: none"> – condition reporting copies – deposit in other institutions - record copies for placement with the accession and catalog files – security copies (replacement of valuable originals in files) – treatment copies (illustrating conservation treatments) <p>At minimum produce the negative and transparency. Use color only if crucial to conveying the nature of the item. Ensure that your negative and transparency film bases are polyester, not cellulose ester. Ensure that the process chosen is long-lived, tested, and if possible is polysulfide toned. Images may be scanned for usage, but the preservation and duplication master copies should be 4" x 5" photographic negatives and transparencies, not digital processes.</p>
<ul style="list-style-type: none"> • Evidential Copy 	<ul style="list-style-type: none"> • Produce identical copies using the same process, format, and technology as that of the original item. Don't modify the document in any way, such as through sound engineering or editing or cutting. Indicate the date the copy was made, your name, the method of copying, and any other requirements that the lawyers provide, plus the statement "this is a true and exact copy."
<ul style="list-style-type: none"> • Exhibition Copy • Fair Use Copy, includes: <ul style="list-style-type: none"> – News Reporting – Parody – Research – Teaching • Performance or Presentation Copy • Presentation Copy • Sales Copy • Usage Copy 	<ul style="list-style-type: none"> • For Outside Uses: If there is no negative or sound master, produce a high quality 4" x 5" or larger master copy negative plus whatever sized print necessary or a reel-to-reel sound file. You may also produce a usage copy by scanning from the negative or sound master. If the researcher is willing to fund the production costs, also have a transparency or cassette produced. Charge back the costs for the entire process (both negative and print production). If a digital copy is requested from the negative, produce a 600 dots-per-inch (dpi) master scan or a very large sound file. Produce appropriately sized derivative (copy) files from the digital master file as indicated by the researcher. Charge back the costs for the entire process (master scan and requested derivatives) to the researcher. Watermark all scans provided to the researcher and all derivative files, but not the original master scan kept in the park. Keep a copy of all the scans in the park. The park then uses the negative or master reel-to-reel and master scan to limit the need for future handling of fragile originals to produce reproductions. • For NPS Use: If producing photographs, moving images, or sound files for NPS purposes (such as exhibitions, fair use, performance or presentation copies (such as for slide shows), follow the guidance under preservation and duplication masters above. Once the masters are produced, use a copy for the special purpose, but keep the first generation copy as the reproduction master (for future duplication purposes) and the transparency or first generation copy as a preservation master (so that when the existing production master (negative or reel-to-reel) wears out, a new production master can be readily produced). Your first or master digital file should be relatively high resolution, such as a 600 dots per inch scan, and should include a gray scale or color bar to facilitate system color calibration and image color correction. Watermark all derivatives made from the master scan. Keep a copy of all the scans in the park.

Figure 4.2. Reproduction Order Notification Sheet

These copies are provided for fair use purposes only, such as non-commercial and non-profit research, news reporting, criticism, parody, and commentary purposes. The provision of copies by the park does NOT authorize publication (including extensive quoting or use in books or magazines, films, tapes, or multimedia works such as the Web or CD-ROMs), exhibition, distribution, resale, performance, reproduction, or the production of derivative works from these items.

Permission for publication (including articles, audiotapes, books, CD-ROMs, films, videotapes, and Web and other Internet usage), exhibition, distribution, resale, performance, reproduction, modification, extensive quoting, or the production of derivative works (for example, calendars, tee-shirts, postcards, posters, scarves, or stationery) must be obtained from the intellectual property rights holders in writing. The National Park Service is NOT necessarily the holder of all rights to these works. Nor is the NPS responsible for researching these rights for individuals who wish to use the works.

The copies provided may include materials that are covered by one or more of the following legal, cultural, or ethical restrictions:

- copyright (US Constitution Article I, Section 8; Copyright Act of 1976; 17 USC 101-810 et seq; Sonny Bono Term Extension Act of 1998 (PL 105-298, 112 Stat. 2827); the Digital Millennium Copyright Act, (PL 105-304, 112 Stat. 2860); and International Treaties such as the Berne Convention for the Protection of Literary and Artistic Works, the North American Free Trade Agreement Implementation Act; and the Uruguay Round Agreements which is 17 USC 104a and 109)
- privacy law (5 USC 552a and state laws including Restatement [Second] of Torts 652A-652I and the Lanham Act Section [15 USC 1125])
- publicity law (state common or statutory laws in almost half the states)
- defamation (including slander or libel-which are state laws)
- obscenity law (state law as well as the Child Protection Act of 1984)
- cultural sensitivities (Executive Order 13007-Indian Sacred Sites)

You as the researcher of these materials are responsible for all lawsuits, civil actions, or related actions, including lawyers and court costs, arising out of inappropriate usage of these copies.

Figure 4.3. Comparison of the Advantages and Disadvantages of 2-D Copy Formats

Comparison of the Advantages and Disadvantages of 2-D Copy Formats	
Advantages	Disadvantages
<p>Digital surrogates have the following advantages:</p> <ul style="list-style-type: none"> • Digital media, such as magnetic tape, are excellent for document management purposes, as they can be rapidly searched and retrieved. • Digital images don't lose quality from generation to generation so copies can be as good as originals. • Digital files require little storage space and storage prices are dropping rapidly. • Digital images are easily manipulated, making them valuable for modeling and simulations. • Digital copies can be mounted on the Web and made available simultaneously to millions of researchers internationally at relatively low cost or shared in vast quantities on a single CD-ROM. • Digital files allow text to be wedded to images, sound, and motion, so that, for example, the catalog record can contain an image of the object. • Digital files can be manipulated to achieve the very best possible image using desktop equipment. • Digital file creation costs are relatively low. • Digital file standards exist, such as the Dublin Core, for exchange and searching of data internationally. • Digital images can be watermarked to ease locating unauthorized uses on the World Wide Web. • Digital images can reach students who learn best by doing or through sound or motion rather than written words. • Digital images have many output formats from thumbnail images that load rapidly on the Web and have little detail to master files of great size with tremendous detail. Different formats are useful for different purposes. • Digital storage standards exist for maximum life. (<i>Note:</i> Store magnetic tape at temperatures below 73°F (23°C) and at 20% RH. Storage of tapes at temperatures below 46°F (8°C) may lead to the lubricant separating from the tape binder. Store optical discs at temperatures below 73°F (23°C) and at 20-50% RH. See <i>COG</i> 19/20 "Care of Archival Digital and Magnetic Media," and 19/19, "Care of Archival Compact Discs.") 	<p>Digital surrogates have the following disadvantages:</p> <ul style="list-style-type: none"> • Digital data system obsolescence is the most important factor in determining the useful life expectancy of digital data. Most systems last 18 months-5 years before data must be migrated. • Digital files on polyester-based magnetic tape last only about 10-50 years if stored in average conditions at 21 °C and 50% RH. • Digital surrogates are not eye-legible. They are totally dependent on fragile, rapidly changing, and expensive hardware and software systems. • Digital images are not evidence as they can be manipulated and changed without leaving any easily visible trace since they are numerical data. • Digital start-up costs are 1/3 for digitizing the items and 2/3 for cataloging, metadata, and quality control on the files produced. • Digital file management costs are 50-100% of the initial project investment during the first 10 years of the file life alone according to the National Archives and Records Administration (NARA). • Digital images are much more expensive to manage over time than paper, as you must refresh the image; manage the hardware, software, and metadata; and continuously migrate the file (every 18 months-five years). • Digital files don't appear the same on all types of computer systems. They are affected by the file format, the color balance of the monitor, the type of computer (Macintosh or IBM compatible PC). • Digital files can't be used by all researchers as some lack computers; others can only work with some file formats. • Digital master files should be housed offline in an uncompressed and non-proprietary file format. Only derivative files should be used. • Digital files require the use of different types of scanners to scan text, oversize items, photographic prints, slides, and other formats. • Digital quality control is a very complex process. • Digital metadata capture and management is a very complex and expensive process. • Digital scanning may need to be done and redone again often if the project is ill conceived, resulting in data that can't be migrated.

Comparison of the Advantages and Disadvantages of 2-D Copy Formats

Advantages	Disadvantages
<p>Microfilm copies have the following advantages:</p> <ul style="list-style-type: none"> • Microfilm (thermally processed silver halide roll microfilm, diazo, and vesicular film) should last at least 100 years if stored at 21°C and 50% RH. • Microfilm is very long-lived and must be duplicated only every 50 years to produce a new printing master. • Microfilm takes up very little space and is cheap to store. • Microfilm--particularly commercial film--is listed in a national registry of microfilm masters to help prevent duplication of effort by several different repositories. Microfilm production standards, manuals, and training courses exist. • Microfilm can accommodate both text and images. • Microfilm comes in a variety of formats, including microfiche, roll film, aperture cards, and card jackets. Each format offers certain advantages. • Microfilm publishing is an established industry that shares and distributes copies of archival and library materials with repositories internationally. • Microfilm is eye-legible with a magnifier and includes internal targets (indices) to help find data. • Microfiche can be filed by topic. • Microfilm is system independent requiring no software. • Microfilm is most effective as a copy technology when entire organized collections or bodies of work must be reproduced and exchanged with other repositories or small numbers of researchers. • Microfilm is a relatively non-damaging copy format that is good for bound and fragile materials and frequently used for oversize items. 	<p>Microfilm copies have the following disadvantages:</p> <ul style="list-style-type: none"> • Microfilm is an awkward access media. Most researchers avoid microfilm. • Microfilm is a poor document management system requiring extensive work in targeting (internal index preparation) and arranging original materials prior to filming. • Microfilm is relatively slow and somewhat awkward as an access medium. • Microfilm is known to require exacting processing and creation work that requires elaborate equipment and highly trained personnel. • Microfilm is NOT a good copy medium for exchanging copies of just a few pages or a small quantity of materials. • Microfilm requires a fairly demanding storage environment. For long-term storage for polyester film based materials the temperature must not exceed 70°F (21°C) and 20-50% RH. • Microfilming work, both archival and library in-house work and work done by commercial contractors, often doesn't meet the ANSI/AIIM standards for permanence. • Microfilming requires extensive quality control testing before acceptance of the final copies.
<p>Motion picture film has the following advantages:</p> <ul style="list-style-type: none"> • Motion picture film (film) offers very long life expectancy (>500 years) if created, stored, and handled correctly. • Film can hold very detailed high quality visual information including sound, color, as well as text. • Film captures motion, time, and sequence easily. • Film is relatively easy to store and transport. • Film can be used in multi-user settings, such as theaters, classrooms, and television. • Film care guidance exists. See <i>COG</i> series. 	<p>Motion picture film has the following disadvantages:</p> <ul style="list-style-type: none"> • Film requires sophisticated equipment, experience, and expensive chemicals to produce. • Motion picture film made by amateurs is rarely satisfactory as high quality and long-lived work. • Film often has poor color stability. • Film bases prior to polyester have been unstable, including cellulose nitrate, cellulose acetate, cellulose diacetate, and cellulose triacetate. • Films are very expensive to produce. • Film requires elaborate editing and quality control procedures.

Comparison of the Advantages and Disadvantages of 2-D Copy Formats

Advantages	Disadvantages
<p>Photographic copies have the following advantages:</p> <ul style="list-style-type: none"> • Photographic films that are black and white polyester-based will last 500 years at 21°C and 50% RH; while cellulose ester films such as acetate, diacetate, and triacetate last 100 years. • Photographs can hold more information than most digital files as the information is chemically encoded and goes down to the molecular level. • Photographs have excellent handling, storage, housing, and management standards already developed. • Photographs are long-lived when created, housed, and stored correctly. • Photographic studios exist in most towns, so local expertise is available. • Photographs are popular with most researchers. • Photographs are the most requested format for most publishers. • Photographs are the most common image format created by artists and the public and the most common image format in archives and museums. • Photographs are eye-legible and can be filed in self-indexing files and function without requiring software or hardware. • Photographs are still the reproduction medium of choice for most publishers and authors. • Photographic guidance is widespread. See the <i>COG</i> leaflets cited in Section A.9, <i>MH-I</i>, Appendix R: Care of Photo Collections; and <i>MH-II</i>, Appendix L: Photography. 	<p>Photographic copies have the following disadvantages:</p> <ul style="list-style-type: none"> • Photographs are easy to produce with poor focus, poor processing, or other problems. • Producing a good photograph requires skill. • Photographs lose visual information each time they are copied with each new generation having less information. • Photographic reproduction system selection is complex. Each copy system has certain advantages and disadvantages: <ul style="list-style-type: none"> - <i>the interpositive process</i> provides the best tonal accuracy but greatest cost - <i>direct duplicate negatives</i> provide the least generational loss but are not good at maintaining image detail - <i>prints from copy negatives</i> are the easiest to produce, but are poor quality • “Photographs don’t lie; but liars photograph” therefore the veracity of photos is overrated as they can be manipulated in a darkroom or by careful composition by a professional photographer. • Photographs such as color images and cellulose nitrate and acetate negatives deteriorate faster than many other document types. These materials are particularly sensitive to humidity and temperature. • Photographs must be produced in a darkroom and photographers must deal with chemicals, elaborate equipment, and escalating supply costs. • Photographic collections take up significant space and require separate indices for access. • Photographic images can serve only a single researcher at a time unless multiple copies are made. • Photographic creation costs are relatively high. • Photographic storage costs are high. Photo storage requires cold storage of valuable original photographs and the duplication of preservation and usage copies. • Photographic copies are not as efficient as digital for document management purposes, as they must be manually retrieved and may require a separate database or index. • Photographs have fairly diverse and demanding storage environmental needs for long-term storage. • Photographs generally are not very effective for multi-user situations, except for slide shows. • Photos are difficult to manage as they fade when exposed to light and are damaged by handling.

Comparison of the Advantages and Disadvantages of 2-D Copy Formats

Advantages	Disadvantages
<p>Sound recordings have the following advantages:</p> <ul style="list-style-type: none"> • Sound recordings are simple to produce. They don't require a professional's services. • Sound recordings are inexpensive to produce. • Sound recordings are popular with scholars as oral histories and music and with the public on the Web and as CDs. • Sound recordings are the tools of choice for certain historians for oral histories. • Sound recordings capture nuances and atmosphere that textual transcriptions lack • Sound recordings that are magnetic have no loss from generation-to-generation of copies. • Sound recordings can be provided to multiple users via the radio. • Sound recording care standards exist. See the <i>COGs</i> described in Section A.9. 	<p>Sound recordings have the following disadvantages</p> <ul style="list-style-type: none"> • Sound recordings made magnetically (tapes) are short-lived (<30 years) • Sound recordings, although easy to produce, are often of very poor quality when made by amateurs. • Sound recordings are awkward to index and search effectively. • Magnetic sound recordings require rewinding and a new tape pack every 3 years or so. • Magnetic sound recordings require migration every 5 years or so or every time the recording/playback system equipment changes. • Sound recordings can be edited, leaving little sign of the reworking, making them poor as evidence. • Spoken sound recordings may require transcription, which is costly and time consuming. • Sound recordings that are magnetic, such as reel-to-reel audiotapes and cassettes, require well-maintained tape players for playback purposes or the tapes may be damaged.
<p>Videotape recordings have the following advantages:</p> <ul style="list-style-type: none"> • Videotape recordings (videos) come in many storage formats from cartridges, cassettes, to reel-to-reel. Videos come in many recording formats from PAL and BETA to VH-S. • Videos are inexpensive and easy to produce. • Videos are popular with scholars and the public. Videos can be made available to multiple users via television, auditoriums, and classrooms. • Videos are the tools of choice for certain types of scholarship such as visual anthropology and video history interviews. • Videos can be copied without generational loss of information. • Video storage standards are known. Store tapes at 5°C (40°F) ±2° and 20% RH ±2%. • Videotape storage, handling, and usage standards exist. See the <i>COGs</i> listed in Section A.9. 	<p>Videotape recordings have the following disadvantages:</p> <ul style="list-style-type: none"> • Videotapes are short-lived (<30 years) • Videotapes made of metal particulate or chromium dioxide pigments are particularly short-lived. • Videos are awkward to index and search effectively. Videotapes require smooth even rewinding every several years to prevent tape layers from sticking together and transferring magnetic particles. • Video recordings require migration (recopying onto new polyester-based tape) every 5 years or so. • Video recordings can be almost invisibly edited, making them poor as evidential sources. • Videos often begin deteriorating after about 16-20 playback sessions or 10-30 years. See <i>COG</i> 19/20. Video equipment must be tuned-up regularly and cleaned so it is dust-and debris free, and dry. • Video recording equipment frame codes vary from machine to machine. Don't use machine-based frame codes for indexing tapes. • Videos produced in the U.S. must be reformatted into other recording formats for use internationally.

Comparison of the Advantages and Disadvantages of 2-D Copy Formats

Advantages	Disadvantages
<p>Xerographic copies have the following advantages:</p> <ul style="list-style-type: none"> • Xerographic copies on acid-free paper stored in a standard office environment of 21°C and 50% RH should last >100 years. • Xerographic copies ideally should be stored at 35°F (2°C) to 65°F (18°C; ± 2°F or ± 1°C maximum daily fluctuation) and 30-50% RH (±3% maximum daily fluctuation.), making them a fairly robust media at near-to-office conditions. • Xerographic copies are cheap, easy, and fast to produce. • Xerographic copies are the most frequently requested types of copy by most researchers. • All parks have xerographic copy equipment and staff who can use it. • Xerographic copy testing for permanence is easy. Simply run a white gloved hand over the toner to see if it has fused, then check the paper acidity. • Acid-free paper for long-lived preservation xerographic copying is easy to locate and use. • Xerographic storage, handling, and housing standards already exist. See the <i>COG</i> leaflets cited in Section A.9. 	<p>Xerographic copies have the following disadvantages:</p> <ul style="list-style-type: none"> • Xerographic copies are easily damaged by rough or frequent handling. • Xerographic copies are easily damaged by frequent viewing in high light situations or frequent copying. Exposure to significant light and form feeders; such as happens when they are frequently copied in xerographic copiers is especially damaging. • Xerographic copies require a fair amount of space to store. When copying non-standard sized items smaller than 8" x 10", you may need more space to house the copy than the original. • Xerographic copies are poor for document management purposes. They are slow to retrieve. • Xerographic copies require a separate index or cataloging system for access or must be filed in self-indexing folders using multiple copies under multiple subject headings.

Figures: 4.4. 2-D Reproductions Cost Recovery Chart for Estimating Time Spent (Sample)

Note: The actual time will depend upon park specifics, such as location, staff expertise, and level of existing cataloging.

Tasks Involved in Reproduction Requests	Minutes
• Ensuring that a duplication request form is filled in correctly and completely (See Section B.5)	5
• Identifying and retrieving the item being requested	10
• Checking the intellectual property right status of the item requested (privacy, publicity, and copyrights) by looking at the deed of gift in the museum records	5
• Answering the request in person, or via mail, phone, e-mail, or fax. All responses should be done rapidly, or at least within 20 days, to acknowledge receipt of the order, to explain the park duplication policy, indicate any cost-recovery fees, and indicate if there are any duplication restrictions due to the copyright status of the item. Use a standardized response modified for each situation.	10
• Stabilizing the item to be duplicated, if necessary. If stabilization is not possible, creation or location of a duplication master to serve as the original for duplication purposes. Not always necessary.	Varies; in this case none is necessary
• Rehousing ,if necessary, and packing the item	15
• Depositing any researcher payments into the appropriate account. <i>Note:</i> Reproduction work should not be done without first receiving all payments, as the NPS is not set up to handle billing and debt collection.	10
• Transporting items to and from the contractor or staff responsible for duplication, and, if necessary, completion of their duplication order form	Varies; in this case 15 minutes
• Unpacking and checking-in items once duplication is done	5
• Inspection returned copy for quality and returned original for deterioration	10
• Reordering duplicates for any missed items or items that don't pass inspection	Varies. Not necessary here.
• Visually inspecting copies against originals for outside researchers to ensure image completeness, appropriate focus, color balance, and similar visual issues	5
• Producing caption and citation	15
• Rehousing, if necessary, and refiling the original material	10
• Verifying payment of contractor and park by researcher	5
• Completing any necessary paperwork, including cover letter to researcher and packaging and mailing duplicate for shipment to researcher	20
• Other	
Total of Work in Minutes	140 minutes per item or 2.33 hours

Figure 4.5. Cost-recovery Fees Formula (Sample)

<i>Cost-recovery Fees Formula:</i>	
\$16.58	Hourly salary and benefit costs per hour at the GS-7/1 rate
x <u>2.33</u>	Number of hours to do the work (See Section C.2 and Figure 4.4.)
\$38.63	
+ \$15.00	Regular duplication costs by external contractor
+ 0.00	Special service fees and costs charged by contractors for rush orders or services
+ \$5.00	Transportation cost and supply costs charged back by NPS
+ <u>0.00</u>	Other special fees (specify)
\$58.63	Total cost

Figure 4.6. Permission to Publish Letter (Sample)

Dear Sir or Madame:

_____ (Park name) has received your request for permission to publish _____

in the following publication (Title) _____

(Author) _____ (Publisher) _____ (Publication date) _____

(Edition number) _____ (Language) _____

_____ (Park name) allows researchers to use park collections for purposes of:

- private research
- non-profit teaching
- parody, satire, commentary, and criticism
- news reporting

in accordance with the fair use provisions of the U.S. Copyright Act of 1976 (17 USC 101-810 et seq. [1988 & Supp. v. 1993]). If you wish to use materials obtained for a non-approved or non-fair use purpose such as a publication or derivative work, **you are responsible for obtaining written permission from all holders of intellectual property rights, which are not necessarily the NPS.** X NP doesn't hold the copyright or other intellectual property rights to all materials within the park. The X NP can only grant permission to use the materials to the extent that the park has the rights.

As a researcher, you signed the Copyright/Privacy Restrictions Statement agreeing that permission to publish, exhibit, perform, reproduce, prepare derivative works from, sell, or otherwise distribute the item must be obtained by the researcher separately in writing from the holder of the original copyright (or if the creator is dead from his/her heirs) as well as from any individual(s), groups, or corporations whose name, image, recorded words, or private information (e.g., employment information) may be reproduced in the source material.

The holder of the original copyright isn't necessarily the National Park Service. The National Park Service is not legally liable for copyright, privacy, or publicity infringement when materials are wrongfully used after being provided to researchers for fair use. I, (insert name) _____, the researcher, understand and agree to the above terms and will indemnify, defend, save, and hold the National Park Service harmless from all claims, demands, losses, or damages (including attorney's fees and expenses) arising out of any legal action, settlement, or adjustment resulting from my not having followed the guidelines provided above.

To the extent allowed by law and by the holders of the intellectual property rights, you _____ have _____ do not have the _____ (Park name) permission to use these materials in _____ the _____ edition of the _____ language work or until _____. This should not be construed as a permission to publish beyond the extent to which the NPS can authorize publication.

Sincerely,

Name
Title
Address
Phone
Fax

Figure 4.7. Wording to be Included in a 2-D Independent Contractor Agreement (Sample to be mailed, e-mailed, faxed, or handed to appropriate potential contractors for signature prior to beginning work as 2-D reformatting contractors)

INDEPENDENT CONTRACTOR AGREEMENT

THIS AGREEMENT (“Agreement”) is entered into by and between _____ (Park name),
National Park Service, a federal agency, and the undersigned (the “Contractor”).

1. Engagement of Services. Contractor agrees to perform services as designated in Exhibit A and hereafter referred to as the “Project” for the _____ (Park name), National Park Service, as follows:

The _____ (Park name), National Park Service, selected Contractor to perform these services based upon the _____ (Park name), National Park Service, receiving Contractor’s personal service and therefore Contractor may not subcontract or otherwise delegate its obligations under this Agreement without the _____ (Park name), National Park Service’s prior written consent. Contractor agrees to perform the services in a professional manner as designated in Exhibit A.

2. Compensation.

2.1 Fees and Approved Expenses. The _____ (Park name), National Park Service, will pay Contractor the fee set forth in Exhibit A for services rendered by Contractor pursuant to this Agreement. Contractor will not be reimbursed for any expenses incurred in connection with the performance of services under this Agreement, unless those expenses are approved in advance and in writing by the _____ (Park name), National Park Service.

2.2 Timing. The _____ (Park name), National Park Service, will pay Contractor for services and will reimburse Contractor for previously approved expenses within ____ days of the date of Contractor’s invoice.

3. Independent Contractor Relationship. Contractor and the _____ (Park name), National Park Service, understand, acknowledge, and agree that Contractor’s relationship with the _____ (Park name), National Park Service, will be that of an independent contractor and nothing in this Agreement is intended to or should be construed to create a partnership, joint venture, or employment relationship.

4. Confidential Information and Intellectual Property Rights.

4.1 Disclosure.

(a) Contractor agrees to disclose promptly in writing to the _____ (Park name), National Park Service, or any person designated by the _____ (Park name), National Park Service, all work product, including but not limited to audiotapes and videotapes, photographs, digital files, computer programs, processes, know-how and other copyrightable material, that is conceived, developed, made or reduced to practice by Contractor within the scope of the Project. [*Note:* The park should clearly define precisely what is to be done here.]

(b) Contractor represents that his performance of all of the terms of this Agreement does not and will not breach any agreement to keep in confidence any confidential or proprietary information, knowledge or data of a third party and Contractor will not disclose to the _____ (Park name), National Park Service, or induce the _____ (Park name), National Park Service, to use any confidential or proprietary information belonging to third parties unless such use or disclosure is authorized in writing by such owners.

(c) Contractor represents that any audiotapes, CD-ROMs, DVDs, digital files, files, microfilm, motion picture film, negatives, photographs, publications, transparencies, videotapes, xerographic copies, or intellectual or tangible works of any sort including copyrighted works relating to the _____ (Park name), National Park Service’s actual or anticipated business or research and development which Contractor has conceived,

developed, made, or reduced to practice at the time of signing this Agreement [hereafter “previously conceived and copyrighted works], have been disclosed in writing to the _____ (Park name), National Park Service, and attached to this Agreement as Exhibit B.

4.2 Confidential Information.

Contractor agrees during the term of this Agreement and thereafter to take all steps reasonably necessary to hold in trust and confidence information which he knows or has reason to know is considered confidential by the _____ (Park name), National Park Service, (“Confidential Information”). Contractor agrees to use the Confidential Information solely to perform the project hereunder. Confidential Information includes, but is not limited to, historic, management, and technical information including:

- the locations of archeological sites, endangered geological and paleontological resources, endangered species nesting and habitat sites, shipwrecks, sacred places, protected caves, wells, and endangered or threatened historical resources such as forts and historic structures
- documentation of ethnographic activities, including sacred ceremonies and food gathering activities
- potentially libelous or slanderous material contained in materials being copied
- images and words of private living individuals lacking model release forms
- images and words of famous individuals lacking permissions

All work done for the _____ (Park name), National Park Service, in terms of creating original images of archival, library, and museum collections and copying materials found in those collections will be held in absolute confidentiality by the contractor and his sub-contractors. Contractor’s obligations with respect to the Confidential Information also extend to any third party’s proprietary or confidential information disclosed to Contractor in the course of providing services to the _____ (Park name), National Park Service. This obligation shall not extend to any information that becomes generally known to the public without breach of this Agreement. This obligation shall survive the termination of this Agreement.

4.3 No Conflict of Interest. Contractor agrees during the term of this Agreement not to accept work or enter into a contract or accept an obligation, inconsistent or incompatible with Contractor’s obligations or the scope of services rendered for the _____ (Park name), National Park Service, under this Agreement.

4.4 Assignment of Work Product.

(a) “Work Product” means the original and copy images, master negatives, interpositives, copy negatives, master digital files, all derivative files of digital materials, master videotapes, outtakes of video or film, camera-ready film, A and B reels of film, microfilm negatives, microfilm copy negatives, microfilm positives including spin-offs such as microfiche or aperture cards, master audiotapes, outtakes of audiotapes, xerographic copies and other electrostatic copy processes, and all other copies or original images of NPS materials, as well as all captions, credit lines, microfilm targets, indices, descriptive databases, contextual information, and similar materials that include tangible works of authorship of any sort solely or jointly conceived, created, copied, duplicated, developed or reproduced during the Project.

Contractor hereby irrevocably assigns, conveys and otherwise transfers to the _____ (Park name), National Park Service, and its respective successors and assigns, the actual objects and all rights, title and interests worldwide in and to the Work Product and any copies, variants, or derivatives, and all proprietary rights therein, including, without limitation, all copyrights, trademarks, design patents, trade secret rights, moral rights, privacy rights and permissions, publicity rights and permissions, and all contract and licensing rights, and all claims and causes of action of any kind with respect to any of the foregoing, whether now known or hereafter to become known.

In the event Contractor has any rights in and to the Work Product that cannot be assigned to the _____ (Park name), National Park Service, Contractor hereby unconditionally and irrevocably waives the enforcement of all such rights, and all claims and causes of action of any kind with respect to any of the foregoing against the _____ (Park name), National Park Service, its distributors and customers, whether now known or hereafter to become known and agrees, at the request and expense of the _____ (Park name), National Park Service, and its respective successors and assigns, to consent to and join in any action to enforce such rights and to procure a waiver of such rights from the holders of such rights.

Any previously conceived and copyrighted works created by the contractor prior to his work with _____ (Park name) are not assigned to the _____ (Park name), National Park Service. However, if Contractor produces new or copies or reproduces different or additional audiotapes, CD-ROMs, DVDs, digital files, files, microfilm, motion picture film, negatives, photographs, publications, transparencies, videotapes, xerographic copies, or intellectual or tangible works of any sort including copyrighted works during the scope of the Project, Contractor grants to the _____ (Park name), National Park Service, all copyrights and a royalty-free, worldwide, perpetual, irrevocable, non-exclusive license, with the right to sublicense, to reproduce, distribute, modify, publicly perform and publicly display such inventions and copyrighted works in the _____ (Park name), National Park Service's products based on the Project.

In the event Contractor has any rights in and to the Work Product that cannot be assigned to the _____ (Park name), National Park Service, and cannot be waived, Contractor hereby grants to the _____ (Park name), National Park Service, and its respective successors and assigns, an exclusive, worldwide, royalty-free license during the term of the rights to reproduce, distribute, modify, publicly perform and publicly display, with the right to sublicense and assign such rights in and to the Work Product including, without limitation, the right to use in any way whatsoever the Work Product. Contractor retains no rights to use the Work Product and agrees not to challenge the validity of the ownership by the _____ (Park name), National Park Service, in the Work Product.

(b) Contractor agrees to assist the _____ (Park name), National Park Service, in any reasonable manner to obtain and enforce for the _____ (Park name), National Park Service's benefit patents, copyrights, and other property rights covering the Work Product in any and all countries. Contractor agrees to execute, when requested, patent, copyright, or similar applications and assignments to the _____ (Park name), National Park Service, and any other lawful documents deemed necessary by the _____ (Park name), National Park Service, to carry out the purpose of this Agreement. Contractor further agrees that the obligations and undertaking stated in this Section 4.4(b) will continue beyond the termination of Contractor's service to the _____ (Park name), National Park Service.

(c) In the event that the _____ (Park name), National Park Service, is unable for any reason whatsoever to secure Contractor's signature to any lawful and necessary document required to apply for or execute any patent, copyright or other applications with respect to any Work Product (including improvements, renewals, extensions, continuations, divisions or continuations in part thereof), Contractor hereby irrevocably designates and appoints the _____ (Park name), National Park Service, and its duly authorized officers and agents as his agents and attorneys-in-fact to act for and in his behalf and instead of Contractor, to execute and file any such application and to do all other lawfully permitted acts to further the prosecution and issuance of patents, copyrights or other rights thereon with the same legal force and effect as if executed by Contractor.

4.5 Return of the _____ (Park name), National Park Service's Property. Contractor acknowledges that the _____ (Park name), National Park Service's sole and exclusive property includes all documents, such as digital files and derivatives, microfilm (including microfiche, aperture cards, card jackets, and roll microfilm), motion picture film (including negatives, positives, outtakes, sound reels, and A and B reels), photographs (including negatives, prints, and transparencies), sound recordings (including audiotapes, CD-ROMs, DVDs, phonograph records, reel-to-reel tape, and other historic processes), videotape

recordings (including cartridges, reel-to-reel tape and other historic processes), xerographic copies (including copies of film and paper) and other materials such as blueprints, drawings, plans, and the captions and indices to these materials in his custody or possession, whether delivered to Contractor by the _____ (Park name), National Park Service, or made by Contractor in the performance of services under this Agreement, relating to the business activities of the _____ (Park name), National Park Service, or its customers or suppliers and containing any information or data whatsoever, whether or not Confidential Information.

Contractor agrees to deliver promptly all of the _____ (Park name), National Park Service's property and all copies, derivatives, surrogates, facsimiles, and variants of the property produced (including digital files on hard drives or diskettes) of the _____ (Park name), National Park Service's property in Contractor's possession to the _____ (Park name), National Park Service, at any time upon the _____ (Park name), National Park Service's request. The Contractor may not keep any copy, reproduction, original, derivative, or variant version for any purpose without prior written permission of the superintendent of _____ (Park name).

4.6 Warranties. Contractor represents and warrants that:

(a) the Work Product was created solely by him, his full-time employees during the course of their employment, or independent contractors who assigned all right, title and interest in their work to Contractor;

(b) Contractor assigns any and all rights, title and interests he may have in the tangible forms of the Work Product and all intellectual property rights protecting them to _____ (Park name). The Work Product and the intellectual property rights protecting them are free and clear of all encumbrances, including, without limitation, security interests, licenses, liens, charges or other restrictions except as set forth in Exhibit C;

(c) Contractor has maintained the Work Product in confidence;

(d) the use, reproduction, distribution, or modification of the Work Product does not and will not violate the rights of any third parties in the Work Product including, but not limited to, trade secrets, trademarks, publicity, privacy, copyrights, and patents;

(e) the Work Product is not in the public domain, or if in the public domain will not be claimed or copyrighted by the contractor;

(f) Contractor has full power and authority to make and enter into this Agreement.

4.7 Performance. Contractor represents and warrants that for a period of [indicate how long here for example five years] following acceptance of the Work Product (i) the product will be free from defects in workmanship and materials under normal use, and (ii) that the product will perform in accordance with the specifications in Exhibit A (Use the standards cited in the Selected Bibliography).

4.8 Indemnification. Contractor agrees to defend, indemnify, and hold harmless the _____ (Park name), National Park Service, their officers, directors, sublicensees, employees and agents, from and against any claims, actions or demands, including without limitation reasonable legal and accounting fees, alleging or resulting from the breach of the warranties in Section 4.6. The _____ (Park name), National Park Service, shall provide notice to Contractor promptly of any such claim, suit, or proceeding and shall assist Contractor, at Contractor's expense, in defending any such claim, suit or proceeding.

5. Termination-Noninterference with Business.

5.1 Termination by the _____ (Park name), National Park Service. The _____ (Park name), National Park Service, may terminate this Agreement for material breach at any time upon fifteen (15) days prior written notice to Contractor. The _____ (Park name), National Park Service, also may terminate this Agreement immediately in its sole discretion upon Contractor's material breach of Article 4 and/or Section 5.3 of this Agreement and/or upon any acts of gross misconduct by Contractor directly affecting this Agreement or the independent contractor relationship.

5.2 Termination by Contractor. Contractor may terminate this Agreement for material breach at any time upon thirty (30) days prior written notice to the _____ (Park name), National Park Service.

5.3 Noninterference with Business. During and for a period of two (2) years immediately following termination of this Agreement by either party, Contractor agrees not to solicit or induce any employee or independent contractor to terminate or breach an employment, contractual or other relationship with the _____ (Park name), National Park Service.

6. General Provisions. This Agreement will be governed by and construed in accordance with the laws of the United States and the State of _____ as applied to agreements entered into and to be performed entirely within State of _____ between State of _____ residents.

This Agreement, including all Exhibits to this Agreement, constitutes the entire agreement between the parties relating to this subject matter and supersedes all prior or simultaneous representations, discussions, negotiations, and agreements, whether written or oral.

No term or provision hereof will be considered waived by either party, and no breach excused by either party, unless such waiver or consent is in writing signed on behalf of the party against whom the waiver is asserted. No consent by either party to, or waiver of, a breach by either party, whether express or implied, will constitute a consent to, waiver of, or excuse of any other, different, or subsequent breach by either party. Contractor may not assign its rights or obligations arising under this Agreement without the _____ (Park name), National Park Service's prior written consent. The _____ (Park name), National Park Service, may assign its rights and obligations under this Agreement.

This Agreement will be for the benefit of the _____ (Park name), National Park Service's successors and assigns, and will be binding on Contractor's heirs, legal representatives, and permitted assignees. If any dispute arises between the parties with respect to the matters covered by this Agreement which leads to a proceeding to resolve such dispute, the prevailing party in such proceeding shall be entitled to receive its reasonable attorneys' fees, expert witness fees and out-of-pocket costs incurred in connection with such proceeding, in addition to any other relief to which it may be entitled.

All notices, requests and other communications required to be given under this Agreement must be in writing, and must be mailed by registered or certified mail, postage prepaid and return receipt requested, or delivered by hand to the party to whom such notice is required or permitted to be given. Any such notice will be considered to have been given when received, or if mailed, ten (10) business days after it was mailed, as evidenced by the postmark. The mailing address for notice to either party will be the address shown on the signature page of this Agreement. Either party may change its mailing address by notice as provided by this Section. The following provisions shall survive termination of this Agreement: Article 4 and Section 5.3. This Agreement is effective as of, _____(date), and will terminate on _____(date), unless terminated earlier in accordance with Section 5 above.

**“THE _____ (Park name),
NATIONAL PARK SERVICE”:**

“CONTRACTOR”:

By: _____

By: _____

Typed name

Typed name

Title

Title

Address:

Address:

EXHIBIT A

Project and Specifications

(Note: Use the ANSI and AIIM standards in the Bibliography listed under the appropriate type of media being produced [for example, photographs or microfilm])

EXHIBIT B

Prior Work Product Disclosure

(Note: Produced by the Contractor to indicate existing materials pertaining to the park to which the contractor has and owns the property rights.)

EXHIBIT C

Exceptions

Chapter 5: Three-Dimensional Reproductions

	<u>Page</u>
A. Overview	5:1
What does this chapter cover?	5:1
What is a three-dimensional reproduction?	5:1
What's the purpose of producing a 3-D reproduction of an object or specimen?	5:2
Who wants these 3-D reproductions?	5:3
How can parks make 3-D reproductions of park collections for NPS purposes?	5:3
Can parks allow others to reproduce park collections for non-NPS purposes?	5:3
What 3-D museum collection items are most frequently reproduced?	5:3
B. Preliminary Policy and Planning Considerations	5:4
What NPS policies and guidelines do I need to know?	5:4
Under what conditions can I grant permission to reproduce a NPS object?	5:4
Can the NPS control the manufacture of a reproduction?	5:5
Can the park license reproductions or charge a fee for a reproduction?	5:5
What management issues do I need to consider?	5:6
C. Reproductions for NPS Purposes	5:7
How do I determine if park staff can make the reproduction?	5:7
What arrangements do I need to make for a park employee to reproduce a museum object?	5:8
With whom should I work to produce reproductions for the NPS?	5:8
Do procedures differ depending on NPS involvement in the reproduction process?	5:8
Why should a park make a reproduction?	5:9
Why should I set up cooperative relationships with cooperating associations and other organizations?	5:9
How do I set up cooperative relationships with cooperating associations and other organizations?	5:10
D. Reproductions for non-NPS Purposes	5:10
What do I need to know to make a decision about the appropriateness of the reproduction request?	5:11
What kind of agreement do I need for a reproduction that is for a non-NPS purpose?	5:11
When should I deny a request for a reproduction?	5:11
E. Reproduction Agreements	5:11
Why should I have a formal reproduction agreement?	5:11
What information should a reproduction agreement contain?	5:12
Should I have a special use permit in addition to a reproduction agreement?	5:14
Should I agree to an exclusive use agreement?	5:14
Should I grant perpetual or international rights?	5:15
What is an appropriate caption to use?	5:15
What information should the interpretive text contain?	5:15
What limitations can I place on a reproduction?	5:16
F. Developing a Standard Operating Procedure for Reproductions by NPS and by Agreement with Others	5:17
Whom should I involve in setting up a park reproduction program?	5:17
What standard operating procedure should I set up for the park?	5:17

	<u>Page</u>
G. Producing a Reproduction	5:19
Is a special use permit required to reproduce an object?	5:19
How do I calculate the costs of reproduction?	5:19
How should I choose a contractor or reproduction company?	5:20
How do I judge the quality of reproductions?	5:21
What steps do I take to prevent collections from being damaged?	5:21
Are there any special considerations for making a mold or a cast?	5:22
How do I mark and label the reproduction?	5:23
What should I do if an inappropriate reproduction is being made or marketed?	5:23
H. Selected Glossary	5:23
I. Selected Bibliography	5:24
J. List of Figures	5:24

CHAPTER 5: THREE-DIMENSIONAL REPRODUCTIONS

A. Overview

1. *What does this chapter cover?*

This chapter contains information on the reproduction of three-dimensional (3-D) museum objects. It outlines the steps to take when you reproduce or arrange for the reproduction of a NPS museum object. Sample agreements for making 3-D reproductions and a glossary are included. The chapter doesn't cover reproducing photographic or digital images of 3-D objects, digital files, microfilm, motion picture film, photographic reproduction, sound recordings, videotapes, and xerographic copies. These topics are covered in Chapter 4: Two-Dimensional Reproductions.

2. *What is a three-dimensional reproduction?*

A 3-D reproduction is a three-dimensional copy of the original. A 3-D reproduction can be one of the following:

- **Adaptation:** an object that is based on an original work in the NPS museum collection whose shape, size, form, or materials have been altered to meet contemporary requirements. An adaptation captures the spirit of the original but isn't considered a copy, such as a branding iron made into a candlestick.
- **Cast:** an exact duplicate of the original but in a different material or medium. It is produced by first making a mold of the original and then making an exact cast from the mold. Examples include paleontology specimen casts.
- **Creation:** a newly developed item that is based on research or inspired by the original object. Examples include a coloring book based on a park theme or a card game based on the battle commemorated by the park.
- **Interpretation*** (also called a derivative work): an object whose shape or design motif is based on a motif or derived from an original work in the NPS museum collection. It is produced in a different context, medium, or form from that of the original. The resulting object may bear little or no resemblance to the original work but preserves some aspect of the original, such as making jewelry based on a portrait in the collection, or putting a pottery motif on a scarf.
- **Reproduction*** (also called a replica): an exact copy of an original object or specimen in the NPS museum collection. A reproduction accurately duplicates materials, proportions, size, color, and decorative techniques. A reproduction is often, but not necessarily, made using the same manufacturing process as the original object. Minor changes in size, materials, or internal structure may be necessary, but the essential character and integrity of the original object is unchanged. Examples include a reproduction of the Martin van Buren dining table and a copy of a hand-woven Navajo rug on exhibit at Hubbell Trading Post.

- **Scale model:** a to-scale copy of an original object or specimen in the NPS museum collection. It accurately renders, to scale, the object or specimen's proportions, color, structure, surface, and materials. Examples include scale models of trains, miniature cannon, vehicles, paleontology, and large mammal specimens.

*The asterisked definitions noted above are adapted from the Henry Francis du Pont Winterthur Museum, Inc., *Requirements for Licensees, Specifications for Winterthur Products, and the Product Development Process* and The Thomas Jefferson Memorial Foundation License Agreement.

3. *What's the purpose of making a 3-D reproduction of an object or specimen?*

A 3-D reproduction makes NPS museum collections more accessible to a wide range of people and promotes the NPS mission of preservation, research, and public enjoyment of park resources. A high quality reproduction stimulates recognition of the people, places, and events the park commemorates. A reproduction fosters appreciation and understanding of the tangible objects people made or used, and of the flora and fauna that are present or were once present in the park.

When you use a reproduction in an exhibition, you need to clearly state that it is a reproduction in the accompanying caption label. As a courtesy and an educational and interpretive tool, you should also explain why you are using a reproduction rather than the original.

A museum object can be reproduced for:

- **Exhibition:** if the original object is too fragile to put on extended exhibit such as a feather headdress or hand-dyed and woven rug. You may reproduce objects that aren't in the museum collection but may be original to the park, for use in an exhibit. Examples include reproducing and exhibiting a writing desk that belonged to the park's eminent figure. When you use a reproduction in an exhibit, the accompanying caption should clearly state that it is a reproduction (refer to Section E.7). As a courtesy and an educational tool, you should also explain why you are using a reproduction rather than the original.
- **Research:** if the object is needed for research and study purposes, such as reproducing a paleontology type specimen or an archeological artifact, such as a projectile point. A reproduction saves the original from extended use and wear. Casts make study specimens more widely available to the research community.
- **Education and Interpretation:** if the original museum object is needed for the park's education and interpretation program where it would be subjected to unacceptable wear or deterioration, or there is a strong possibility of breakage, vandalism, or theft (See Chapter 1, Section H, Interpretation Issues.)
- **Commercial Use:** as an attractive sale item.

4. *Who wants these 3-D reproductions?*
- Many people use 3-D museum reproductions. Professionals who want these reproductions include museum, education, and research professionals, such as curators, exhibit designers, educators, interpreters, and discipline specialists, and educational organizations. Many private individuals, contractors, and for-profit organizations that make reproductions for commercial purposes would also like to have them.
5. *How can parks make 3-D reproductions of park collections for NPS purposes?*
- Parks can make reproductions in three ways:
- The park can reproduce objects in-house to incorporate into an exhibit or to fill a gap in the museum collection.
 - The park can hire a contractor to reproduce a museum object or specimen to include in an exhibit or to fill a gap in the museum collection, that is, for use in-house.
 - The park can enter into an agreement with a cooperating association, which in turn enters into a third party agreement with an individual contractor or organization (for-profit or nonprofit) to reproduce a museum object for distribution or sale. Three-dimensional reproductions can be sold through:
 - the park cooperating association shop
 - the regional cooperating association
 - non-NPS museum shop(s)
 - catalog sales
 - electronic sales, such as the World Wide Web
6. *Can parks allow others to reproduce park collections for non-NPS purposes?*
- Yes, through an agreement, the park can allow a contractor or organization (for profit or nonprofit) to reproduce a museum object for sale or distribution. In this instance the park isn't involved in the reproduction, distribution, and sales process.
- However, it isn't always possible to control the manufacture of a park museum reproduction. An individual might take a picture or make a sketch of an object in the park museum during regular hours, and then go home and make a reproduction without entering into an agreement with the park. In this instance, the park really has no control over the reproduction, and it can't be an authorized NPS reproduction.
7. *What 3-D collection items are most frequently reproduced?*
- The most frequently reproduced items are:
- *objects*, including cannon, clothing, furniture, jewelry, and household items, such as clocks, cutlery, coins, mugs, vessels, dinnerware, wall coverings, and sculpture
 - *specimens*, including paleontology and biology items, such as botanical, mammal or ornithology specimens

Documents, manuscripts, and images, including photographs (traditional or digital) of three-dimensional objects are the most frequently reproduced NPS museum collections. For additional information, refer to Chapter 4: Two-Dimensional Reproductions, and *Museum Handbook*, Part II (*MH-II*) Appendix L: Photography.

B. Preliminary Policy and Planning Considerations

1. *What NPS policies and guidelines do I need to know?*

Familiarize yourself with the sections related to managing museum collections in the NPS policies and guidelines listed in Chapter 1, Section C.3; Chapter 2: Legal Issues; and the guidelines below:

- Director's Order #32: Cooperating Associations
- Director's Order #21: Donations and Fundraising
- Director's Order #53: Special Park Uses and *Reference Manual 53* (formerly NPS-53)
- NPS Cooperative Agreement Authority (February 2, 1998)
- Omnibus Consolidated Appropriations Act of 1997 (PL 104e-208 [September 30, 1996], Title I, National Park Service, Administrative) allows the NPS to *enter into cooperative agreements...for the public purpose of carrying out NPS programs....*

2. *Under what conditions can I grant permission to reproduce a NPS object?*

The superintendent can authorize the reproduction of a NPS museum object, if the issues outlined in Chapter 1: Evaluating and Documenting Museum Collections Use, are addressed. If you grant permission to one non-NPS individual or organization to reproduce a museum object, then you should allow the same access to other non-NPS individuals or organizations. However, you can deny permission to reproduce the object if conditions have changed since you first authorized a reproduction, or if management issues outlined in Chapter 1, Section C, become a concern. This includes a change in object condition or if you determine that additional handling or the reproduction process itself may cause damage. You can limit access to specific times because of limited park resources such as staffing.

You should provide access to museum collections in order to make a reproduction in accordance with NPS:

- policy
- preservation and protection guidelines
- access and use guidelines
- confidentiality of resources data

Remember that only the superintendent can authorize the reproduction of a museum object or specimen.

3. *Can the NPS control the manufacture of a reproduction?*

Yes and no.

- Yes, the NPS can control the reproduction if there's a signed reproduction agreement between the concerned parties. The NPS can control the reproduction if:
 - the NPS requested and contracted for the reproduction
 - the reproducer works with the park to develop and distribute the product as an authorized authentic NPS reproduction

The reproduction agreement signed by the NPS and the contractor or organization should stipulate all the conditions and specifications that must be met. It should indicate what steps will be taken if the conditions aren't met.

Every reproduction of a NPS museum object must carry a reproduction mark, NPS credit, caption and interpretive label.

Refer to Section E.6 for detailed information on NPS credits and captions.

- No, the NPS can't control the reproduction if there isn't an agreement between the NPS and the reproducer. If the reproducer develops a 3-D reproduction on his or her own, basing the reproduction on memory, interpretation, or a photograph taken in an area that is open to the general public (see Chapter 6, Section D, Filming and Photography in Spaces that House Museum Collections), then the NPS has no control over the reproduction. In this instance, the reproducer has had the same access to the collections as the general park visitor. The park didn't provide any special access to the collection and therefore has no control.

It is also possible that a person may have had access to the object and studied, measured, and photographed the object, and then at a later date decided to reproduce the object without an agreement. In this instance, the NPS has no control over the reproduction. However, the reproduction can't be considered or called a NPS authorized reproduction. If the reproducer calls the item an authorized NPS reproduction, the park should consult with the regional/SO curator and solicitor to determine what action to take.

4. *Can the park license reproductions or charge a fee for a reproduction?*

No. The NPS doesn't have the authority to license products or receive royalties or a fee for making a reproduction of a museum object or specimen. The NPS may recover its associated costs if a special use permit for the reproduction has been issued. A third party, such as the park cooperating association, can license a product. The park, however, needs to follow procedures outlined in Figures 5.3 and 5.4, and in Chapter 3, Section E.17, How do I obtain licenses and permissions? Refer to Chapter 6, Section B.7, and Director's Order #53: Special Park Uses, and the accompanying *Reference Manual 53*. The specifics of recouping costs should be spelled out in the special use permit and any agreement the park signs. Establish a mechanism for the park museum to recover costs in accordance with Special Park Uses. Work with the park administrative and contracting officers to make sure the reproduction costs go into a cost recovery account.

5. *What management issues do I need to consider?*

Carefully weigh all the legal, ethical, cultural, management, scientific, preservation and protection, documentation, and interpretive issues outlined in Chapter 1: Evaluating and Documenting Museum Collection Use, when considering a reproduction request. Evaluate all requests fairly and equally, whether it's an in-house, contractor, or a commercial or nonprofit organization request. Work with a museum collection committee as recommended in Chapter 1, Section C, Management Issues, to develop park reproduction procedures and to evaluate all requests to reproduce a museum object or specimen.

If you permit a non-NPS requester to reproduce a museum object for non-NPS purposes once, you must permit it to other non-NPS requesters, unless there is a legitimate management reason not to do so. Each request requires you to reconsider all management issues outlined in Chapter 1, Section C. If the object condition has deteriorated since the last authorized reproduction, or the proposed reproduction process or material may damage the object or specimen, then you can deny the request.

Evaluate the following issues when considering a request:

- **Legal restrictions:** Refer to Chapter 2: Legal Issues, for detailed information on laws and regulations governing museum collections. The requester needs to obtain written permission from the rights holder to reproduce objects that are covered by:
 - copyright
 - patent
 - trademark (or service mark)
 - license

Refer to Section E, Glossary, for definitions of these terms.

- **Donor restrictions:** Check the accession folder to make sure that there are no donor stipulations that restrict reproduction of an object. Refer to Chapter 2, Section H.5, How do donor restrictions affect use?
- **Ethical implications:** Refer to Chapter 1, Section D, Ethical Issues, when you consider ethical issues prior to permitting an object to be reproduced.
- **Cultural concerns:** Refer to Chapter 1, Section C, Cultural Issues, for additional information.
- **Preservation and protection requirements:** Before allowing a reproduction to be made, make sure that the object or specimen isn't placed at risk or can be damaged by the reproduction process or materials used in the process, such as those used in mold or cast making. Where possible and practicable, have the object reproduced at the park. This will allow you to supervise the process and ensure that adequate preservation and protection precautions are being taken. Limit the

object's exposure to unnecessary or excessive handling and light and keep the temperature and relative humidity stable and within the ranges outlined in the *MH-I*, Chapter 4: Museum Collections Environment.

Supervise access to the object while the person who is reproducing the object documents the object. If the object can't be reproduced at the park, you must generate an outgoing loan. If appropriate, the borrower should complete a Standard Facilities Report, see *MH-II*, Chapter 5: Outgoing Loans. Verify that the object will be carefully handled, stored, and protected at the reproduction site. Inspect the site. Make sure that the object is stored in accordance with the *MH-I*, Chapter 7: Museum Collections Storage, for the duration of the loan. For additional guidance, refer to Chapter 1, Section G, Preservation and Protection Issues.

- **Handling, packing, and shipping:** Make sure that all object handling, packing, and shipping procedures, from the time the object is taken from the park museum to its return, follow the handling procedures outlined in the *MH-I*, Chapter 6: Handling, Packing and Shipping Museum Objects.
- **Documentation:** Record all activities associated with the reproduction process in accordance with Chapter 1, Section J, Documentation. Refer to Figures 5.1-5.4 for additional information. Make sure the requester completes all NPS required forms and that there is a signed agreement outlining conditions and detailed specifications.

Account for reproductions that come into the park's possession in accordance with procedures outlined in the *MH-II*, Chapter 4, Section IV, Reproductions, Living History Items, Exhibition Aids, and Outdoor Exhibits. For reproductions in the museum collection, file all documentation in the accession or catalog folder. You can also establish a reproduction folder that contains duplicate documentation for ready reference.

C. Reproductions for NPS Purposes

1. *How do I determine if park staff can make the reproduction?*

Determine whether NPS staff has the skill, tools, equipment, and time to make a high-quality reproduction. If not, identify a suitable contractor or commercial organization to make the reproduction. Make sure that the product is appropriate to the park mission. Remember that manufacturing a good reproduction takes considerable staff commitment and resources. Calculate how much it will cost you to make a reproduction in-house, as opposed to having it made by an outside contractor.

- Don't allow unskilled or untrained staff to do the reproduction work. Survey park staff to identify skilled professionals or artisans who have the necessary expertise. A glass blower or metal smith in the park living history program or a paleontologist who is skilled at making specimen molds and casts may be an ideal candidate.
- Train the individual in handling museum objects and specimens.

- Make sure that the park has the right supplies and equipment to produce a high quality reproduction. By owning the tools and equipment, blueprints, or drawings, the park will have greater control of the process and development of reproductions in the future.

2. *What arrangements do I need for a park employee to reproduce a museum object?*

Make these arrangements:

- Get the supervisor's authorization in writing for the individual to work on the project.
- Have a signed reproduction agreement with the individual NPS staff member to make the reproduction as part of his or her NPS job responsibility.
- Allot sufficient time to the project to ensure its timely completion. Remember that doing a project in-house doesn't necessarily save the park money and may even take an unacceptably long time.
- Follow the same steps in the reproduction process that you would if working with an outside contractor or manufacturer

3. *With whom should I work to produce reproductions for the NPS?*

Work with individuals or organizations experienced in manufacturing and, if you plan to distribute reproductions, distributing reproductions. The park cooperating or regional association should be able to provide you with names of possible contractors. Select an individual or organization that has:

- experience in developing, manufacturing, and distributing reproductions
- the infrastructure to initiate and complete the reproduction cycle
- qualified staff and equipment to manufacture, distribute, and market the reproduction items
- ability to determine whether the items you want to reproduce have broad appeal

Most parks work with the park cooperating association, which in turn, works with an individual or organization. The park cooperating association, in accordance with Director's Order #32, can ensure that the park museum program can benefit from the reproduction process. You can also work directly with a contractor or for-profit or nonprofit organizations. However, the park can't receive any funds, other than cost recovery monies from this activity. Whichever route you select, make sure that the reproduction agreement includes the sample wording found in Figures 5.1, 5.2, 5.3 and 5.4.

4. *Do procedures differ depending on NPS involvement in the reproduction process?*

The issues you need to evaluate, such as staffing, legal, preservation and protection, and cultural and ethical concerns apply to all reproductions. Generally, you should follow the same procedures whether you're producing the reproduction using:

- in-house staff
- park cooperating associations

- contractors
- commercial product development companies
- nonprofit organizations

5. *Why should a park make a reproduction?*

The park can make a reproduction or have a reproduction made:

- for in-house use, such as an exhibit or interpretive program
- available for sale and distribution through the park cooperating association

The park should enter into an agreement with the cooperating association authorizing the cooperating association to enter into agreements with third parties to produce a reproduction. The park agreement with the cooperating association gives the park control over the quality of the reproduction. See Figure 5.2 for sample wording to include in such an agreement. Monies resulting from these activities can be used to benefit the park museum program in accordance with guidelines outlined in Director's Order #32. Financial terms between the cooperating association and the third party contractor are handled independently of the park. You don't need a special use permit when you work with the cooperating association.

- available for sale and distribution through an individual contractor, commercial company or nonprofit organization

The park is not authorized to, and therefore can't receive proceeds that result from this activity. However, you can recover costs if a special use permit has been issued (see Figure 5.3). You'll need a reproduction agreement and a special use permit. Work with the park contracting officer to develop the reproduction agreement and a museum cost recovery account.

The superintendent must approve all 3-D reproduction requests.

6. *Why should I set up cooperative relationships with cooperating associations and other organizations?*

NPS park cooperating associations provide excellent opportunities for parks to increase access to museum collections. In regard to reproductions, the purpose of cooperating associations is to:

- assist parks in supporting museums, exhibits, publications, and other aspects of the park interpretive, educational, and scientific research programs
- sell interpretive and educational materials related to areas and themes of the National Park System
- sponsor or co-sponsor the development and production of materials that directly or indirectly increase the understanding and appreciation of individual park units, the National Park System, or the National Park Service

- Work with the park to develop a park reproduction or act as a co-sponsor with a third party to develop reproductions for distribution and determine if the reproduction:
 - is fairly priced
 - is in keeping with the park’s museum collection as outlined in the scope of collection statement (This includes the reproduction content, method of manufacture, durability and packaging.)
 - fits into the overall balance of the cooperating association’s interpretive sales items

7. *How do I set up cooperative relationships with cooperating associations and other organizations?*

Begin with a formal agreement:

- Develop a reproduction agreement that outlines the specifications, limitations of production, time, and if applicable, a cost-recovery mechanism. Refer to Section E.2, and Figures 5.1-5.4 for sample wording to include in an agreement.
- Ensure that the agreement includes:
 - a patent, trademark, and license statement outlining the responsibility of the contractor or organization to obtain permission to reproduce the object

For example: The reproducer (contractor or organization) agrees to obtain written permission to reproduce the item from the patent, trademark, and license holder.

- a statement that holds the NPS harmless from legal claims arising from the manufacture, sale, and use of the reproduction

For example: The reproducer (contractor or organization) will indemnify, save, and hold harmless the United States against all fines, claims, damages, losses, judgments, and expenses arising out of, or from, any omission or activity of the manufacture, sale, and use of the reproduction.

Refer to Director’s Order #32 and to Chapter 3, Section J.6.

D. Reproductions for Non-NPS Purposes

You may receive a request from a non-NPS entity to reproduce a NPS museum object or specimen. Whether the entity is a federal or non-federal organization, you should answer the questions listed below.

1. *What do I need to know to make a decision about the appropriateness of the reproduction request?*
- In addition to satisfying the management concerns outlined in Chapter 1, you need acceptable answers to the following questions:
- Will the reproduction enhance and support the research and educational mission of the NPS and the park?
 - Is the reproduction related to the park's interpretive themes?
 - Does the reproduction help park visitors better understand and appreciate NPS park museum resources?
 - Will a greater number of researchers and the general public have increased access to NPS museum resources?

If you determine that the reproduction request and subsequent use is potentially problematic, carefully document your findings. Consult with the regional/SO curator and the NPS solicitor. Send your recommendation and supporting documentation to the superintendent for approval.

Always ask the same questions and apply the same procedures to all reproduction requests. This will ensure that the park's actions are consistent and fair.

2. *What kind of agreement do I need for a reproduction that is for a non-NPS purpose?*
- When you develop a reproduction agreement for non-NPS use, include the information outlined in Section E.2 and refer to the figures at the end of this chapter.
3. *When should I deny a request for a reproduction?*
- You should deny a request to make a reproduction of all or part of a museum object or specimen when:
- the making of the reproduction has the potential to harm or degrade the museum object or specimen
 - NPS staff aren't available to supervise the process
 - the process significantly interferes with regular museum operations
 - the reproduction presents possible legal liability problems for the NPS, such as a functioning historic firearm, edged weapons, or bow and arrow, or any object relating to alcohol or tobacco
 - copying of the object would violate copyright or other legal restrictions associated with the object

E. Reproduction Agreements

1. *Why should I have a formal reproduction agreement?*
- A formal reproduction agreement protects the NPS and all the park's rights associated with the museum objects being reproduced. The reproduction agreement outlines the rights and responsibilities of the park and the staff member, contractor, or commercial organization. It allows the park to

maintain control over all the steps in the development and implementation of the reproduction program. See Figures 5.1, 5.2, 5.3, and 5.4 for sample reproduction agreements.

2. *What information should a reproduction agreement contain?*

The reproduction agreement should contain the information noted below. See Figures 5.1-5.4 for sample wording to include in a contract or agreement.

- contractor or organization; address and fax and phone numbers; responsible official
- project description, including
 - an overview of what will be produced
 - the technique used to reproduce the object
 - detailed specifications, including dimensions, weight, color and texture of the finished product
 - what access to the original will be granted
 - the location(s) where the product will be manufactured
 - distribution information, if appropriate
- list of objects or specimens to be reproduced, including catalog number, object description, and object condition report
- object captions, credits and interpretive text
- limitations and restrictions
- duration of the agreement, including:
 - start and end date
 - renewal terms, if appropriate

Don't make any duration "perpetual" or "indefinite."

- use of the reproduction, indicating whether the approved usage is:
 - non-exclusive
 - one time (single)
 - limited (For example, the reproduction may only be sold through NPS cooperating association shops.)
- number of editions to be made

- geographic area covered by the agreement:
 - restricted to the USA where possible
 - other countries added separately to the agreement
- prototype specifications, including material, proportions, structure, finish, color, and design
- reproduction process, including technique and materials to be used in making the reproduction, cast, or mold
- production and delivery schedule
- cost recovery fees and payment schedule
- statement that contractor performance is subject to NPS and cooperating association approval
- object handling techniques
- documentation and record keeping requirements
- quality control, including:
 - quality standards
 - how and when the prototype will be reviewed and approved
 - who will evaluate and approve work samples, the approval schedule, and how the work will be evaluated
- schedule for continuing submission of prototypes or samples
- park's authority to inspect the contractor or organization's operation
- compliance with applicable laws
- statement that no modifications are to be made to the reproduction agreement without the park's prior written approval
- statement that park retains the right to withdraw approval in the event of an unacceptable modification or an unfavorable reflection on the park caused by the product
- instructions for packing and shipping originals and reproductions
- product delivery
- product liability insurance

- intellectual rights, including copyright and trademark and patent rights provisions

The reproducer assumes the responsibility of obtaining permission to reproduce objects with trademark, copyright, and any other rights, and patent protection. Refer to the glossary and Chapter 2: Legal Issues, for additional information.

- warranties and indemnification
- dispute resolution, such as mediation or non-binding arbitration
- termination of agreement
- miscellaneous information

The NPS needs a reproduction agreement in place, whether it is with the park cooperating association or with a contractor or organization. The reproduction agreement allows the NPS to establish specifications and maintain quality control. When you work with a cooperating association, make sure that the cooperating association handles all the financial terms between the cooperating association and the organization independently of the NPS. If you're working directly with a contractor or organization to sell and distribute reproductions, and the project was initiated by the contractor or organization and not the NPS, you should have a special use permit in addition to the reproduction agreement. You can recover costs if a special use permit has been issued.

To minimize your workload, write an agreement that lasts for two to five years. For sample wording to include in an agreement refer to Figures 5.1-5.4.

Don't sign a contractor or manufacturer's standard form or contract. Always use a NPS-generated agreement.

Consult with the park contracting officer and the regional/SO curator and contracting officer and get NPS solicitor review of the document.

3. *Should I have a special use permit in addition to a reproduction agreement?*

Generally, if the project was initiated by the NPS, you don't need a special use permit. However, you should have a special use permit in addition to the reproduction agreement if the project meets the criteria for special use, and you want to be able to recover reproduction costs. Complete the permit and set up cost recovery arrangements in accordance with the procedures outlined in Director's Order #53. You can download a copy of the document from <<http://www.nps.gov/refdesk/DOrders>>. You should also refer to Chapter 6, Section E.5. Attach a copy of the agreement conditions to the special use permit and make a note on the special use permit that the terms of the attached agreement must be met.

4. *Should I agree to an exclusive use agreement?*

No, never grant any organization exclusive use of NPS museum collections. NPS museum collections are held in trust for all the American people. You can't grant exclusive rights to an individual, group, or organization.

Permission to reproduce any object granted to one contractor or organization should be granted to all other requesters subject to NPS policy and procedural guidelines. However, you can refuse permission if the management issues identified in the Section C, Management Issues, aren't addressed.

If the superintendent approves the request and the requester sends you a standard form for NPS to grant exclusive use and rights, don't complete it. Always use a NPS-generated agreement that outlines conditions and detailed specification of reproduction.

5. *Should I grant perpetual or international rights?* **No, never.** Limit all use to a specific time and/or geographic location. Don't grant requests for all international rights or all rights in perpetuity. Grant rights for each defined use, time period, and location. For example, you might grant rights to a vendor to reproduce and distribute Rodman cannon, Catalog Number PARK 4542, in the United States for a period of three years. This will ensure that the NPS retains control over the reproduction process. Requesters can renegotiate or amend existing agreements to accommodate additional uses.

6. *What should be included in a caption?* NPS procedures require that all users of NPS collections, including reproducers, cite a NPS caption. Cite the following elements in a NPS caption:

- item title in quotes, if applicable
- object name
- brief description, including materials and measurements
- date(s)
- artist/maker
- National Park Service
- park or center name
- catalog number

For example: "Coffee Urn; silver, ivory and steel; Rococo style; Height 52.1, Width 31.75 cm; circa 1825; attributed to Samuel Kirk; National Park Service; Hampton National Historic Site, HAMP 3505"

Always include "National Park Service" and the park name on captions and credits.

Refer to Chapter 3, E.18, What do I need to know about writing captions?

7. *What information should the interpretive text contain?* In addition to the caption, museum reproductions should carry accompanying interpretive text that provides additional information on the original museum object. The text should benefit the public, increase knowledge, and promote the visibility of the park museum collection. It should further the educational,

interpretive and research goals of the NPS. You should write the text or provide the information to the reproducer. Review the final interpretive label before production to ensure its accuracy.

The short interpretive text that accompanies the reproduction should include information on the following:

- how the reproduction was made
- how the reproduction differs from the original
- where the reproduction was made
- where the original museum object was made
- who made the original
- the function and purpose of the museum object
- cultural, artistic, historical, or scientific significance of the item, including associations with notable individuals or groups, historic events, or significant places, information about usage, and any other pertinent information
- how the consumer should care for the reproduction
- the park's museum collection

You, or the reproducer can combine the caption and interpretive text into a single document to be provided with each reproduction. When you use a reproduction in an exhibit, the accompanying caption should clearly state that the item is a reproduction.

8. *What limitations can I place on a reproduction?*

If you commissioned the reproduction or the vendor is marketing the reproduction as a NPS-approved, authentic copy of a NPS museum object, you can require that:

- the park approves the reproduction
- the reproduction meets the specifications of the agreement, including:
 - design
 - pattern
 - manufacturing technique
 - dimensions
 - proportion
 - structure
 - material

- color
- surface finish
- each product component carries a “reproduction” mark
- the weight of the reproduction differs from the weight of the original, if possible

This information should be noted in the caption and in the accession and catalog folder. This is done to avoid possible confusion between the original and the 3-D reproduction.

- planned differences in manufacture and the final product are noted in the caption, such as a different color wallpaper used with the same design

F. Developing a Standard Operating Procedure for Reproductions by NPS and By Agreement with Others

1. *Whom should I involve in setting up a park reproduction program?*

Work with the museum collection committee described in Chapter 1, Section C.1, to develop park reproduction procedures and evaluate reproduction requests. The committee makes recommendations to the superintendent who approves all reproductions. The committee should include the park curator and consult with the following individuals, as appropriate, if they aren't on the committee:

- conservator
- contracting officer
- cultural resource manager
- historian
- interpreter
- natural resource manager
- public affairs officer

Consult with the regional/SO curator, NPS solicitor, and associated groups, as appropriate.

2. *What standard operating procedure should I set up for the park?*

Develop the park standard operating procedure (SOP) for reproductions in consultation with the committee and key park participants. The SOP should outline the park's resources, such as in-house staffing, contractors, nonprofit, and for-profit commercial organizations, and the nature of the park museum

collections. The committee should review all reproduction requests and make recommendations to the superintendent.

To develop a park SOP:

- Define objectives of the SOP.
- Develop a standard restrictions procedure explaining how the park will handle requests to reproduce objects and specimens when such use is restricted by law or NPS management policy and procedures.
- Establish a mechanism to evaluate reproduction requests against management needs of adequate staffing, supervision, space, preservation and protection, and cultural and ethical concerns.
- Identify who will oversee the production of the reproduction.
- Identify under what conditions reproductions won't be allowed.
- Determine how you will identify and meet park-affiliated groups' concerns.
- Determine how to inform the contractor of his or her legal obligations to obtain copyright and other rights and permissions, including use of trade or service marks, patents, and licensed products.
- Develop a production and delivery schedule.
- Establish a procedure for the object to be measured, photographed, and digitized in preparation for the project, including the completion of an object condition report.
- Determine how to select the contractor or manufacturer for NPS initiated projects.
- Establish a mechanism to calculate and receive cost recovery monies.
- Identify potential liability issues associated with making and distributing reproductions. Don't reproduce items that may contain risk or that may harm persons or property, such as firearms or knives. Include language in the agreement to protect and indemnify the NPS from possible litigation. Consult with the NPS solicitor and refer to the sample wording in Figures 5.1-5.4.

Develop only reproductions that are safe for consumer use.

- Arrange for adequate insurance coverage in consultation with the park administrative officer and regional/SO curator.
- Make sure all reproductions carry a permanent mark such as "reproduction."

- State standards for the caption, credit, and interpretive text for each reproduction.
- Develop an agreement on reproduction procedures in consultation with the:
 - park contracting officer
 - park administrative officer
 - regional/SO curator
 - regional contracting officer
 - park cooperating association
- Develop a park reproduction agreement template (see Figures 5.1-5.4) with applicable conditions and detailed specifications that can be modified for each project.
- Determine when the park will issue a special use permit in conjunction with a reproduction.

G. Producing a Reproduction

1. *Is a special use permit required to reproduce an object?*

Yes and *no*.

Yes, if you're working directly with a non-NPS entity that plans to sell and distribute or otherwise use museum reproductions for its own purposes, you'll need a special use permit and a reproduction agreement. You may also issue a special use permit in addition to a reproduction agreement if you are working with a cooperator, other than the park cooperating association, to sell and distribute or otherwise use museum reproductions for a purpose that will benefit the NPS. You may recover costs if a special use permit has been issued. Refer to Section E.3 for additional information.

No, you don't need a special use permit if you're working with a cooperating association, as you'll have an agreement with the association that is subject to Director's Order #32. Also, if you are working directly with a vendor and have a contract, you don't need a special use permit. Generally, if the project was initiated by the NPS, you don't need a special use permit. However, you should have a special use permit and a reproduction agreement if the project meets the criteria for special use. Refer to Section E.1 for more information.

2. *How do I calculate the costs of reproduction?*

To determine costs, identify all related activities. Calculate reproduction costs by determining the costs to:

- identify the object to be reproduced
- locate pertinent documentation in the accession and catalog folders

- research the objects
- document object measurements
- stabilize and conserve the object
- travel in association with the reproduction
- photograph the object
- purchase materials, supplies, and equipment, if appropriate
- transport the object or specimen to the contractor, if appropriate
- pay staff salaries and benefits associated with the reproduction
- supervise the contractor's access to the object or specimen
- inspect the prototype
- control quality during production
- pack and mail the reproduction
- produce captions and credits
- complete necessary paperwork, including outgoing loan forms and object condition reports
- manufacture actual prototype and reproduction, if appropriate
- furnish utilities
- determine environmental and cultural compliance
- use vehicles and other equipment

You may recover costs only if you generate a special use permit.

The NPS has the authority to recover and retain costs associated with making museum reproductions if a special use permit has been issued. Refer to *Reference Manual #53, Chapter 7: Management of Permit Fees*, for detailed information. You'll need to work with the park administrative and contracting officer to set up an appropriate park account to receive cost recovery funds. Refer to Section E.1 of this chapter.

3. *How should I choose a contractor or reproduction company?*

Consult your contracting officer, obtain recommendations from colleagues, and follow NPS contracting guidelines.

- Seek out contractors or companies that have made similar products, particularly museum reproductions, successfully. You don't want this to be a learning experience for the contractor.
- Find out as much as you can about the company. Determine whether the contractor or manufacturer has the equipment and capacity to make a high quality reproduction. Check on the contractor's work. Evaluate other items the contractor has reproduced.
- Establish that the quality of work is high and that the work is completed in a timely fashion.
- Evaluate staff qualifications and expertise.
- Make sure staff are trained to handle museum collections.
- Visit workshops, laboratories, and studios.
- Examine and evaluate the products the company has produced.
- Inspect the facility, if possible.
- Develop and evaluate a prototype.
- Determine if the company can satisfactorily deal with related legal and distribution issues.

4. *How do I judge the quality of reproductions?*

Compare the final product or prototype with the original. Determine whether the method of manufacture and the materials and craftsmanship meet the highest standards and the terms of your agreement.

- Are the designs and patterns, technique of manufacture, material, and color true to the original?
- Is the cast an exact replica of the original specimen? Take a close look at the two side-by-side to establish that the cast is truly identical to the original specimen in all but weight and material.
- Will the reproduction withstand normal wear and tear appropriate to its use, such as a reproduction chair that can be subjected to daily use for an extended period?

5. *What steps do I take to prevent collections from being damaged?*

Take the following steps:

- Always inspect the original museum object closely before initiating the work.
- Complete a detailed object condition report. (See *MH-II*, Chapter 5, Section C.3, Condition Reports and Photographs, and Figure 5.6, Object Condition Report Form 10-637. The form can also be printed from ANCS+.)

- Allow only NPS museum staff to handle an object that is not in good and stable condition.
- Supervise photography, measurement, and examination of the object.
- Take detailed record and condition photographs of the object.
- Make certain that the reproduction process and materials don't damage the object or specimen. Generally, only the making of a mold involves direct contact with the original. The specimen itself must be sturdy and its surface stable enough to withstand adherence and removal of molding material.
- Make sure the molding material is inert and will not harm the object or specimen.
- Make sure reproduction staff are trained to work with museum collections if the work is being done off-site.
- Monitor production.
- Visit the site regularly, if possible.

6. *Are there any special considerations for making a mold or a cast?*

Yes. The original object or specimen must be in stable condition in order to make a mold or a cast. Parks frequently make casts of paleontology specimens and less frequently of other items, such as lithic tools. Casts are used to replicate paleontological type specimens and rare or very large specimens. Molds may be made just of sections of an object or specimen to show tool marks on bone, use marks on lithic material, basketry impressions on ceramics, or fossil tracks in order to facilitate study. Molds and casts are also made of objects such as jewelry or sculpture. Casts often document particular features or relationships of bones before preparation is completed. Casts can also be made of a specimen after it is prepared. Molds and casts can be made of specimens in situ or in the laboratory.

To get an exact duplicate of the specimen, first make a mold. Then pour casting medium into the mold to get a cast of the original. The mold itself (latex peel, silicone rubber, or other material) and a cast of the mold can be produced and one or both made available for study.

Record all materials used in making a mold or cast, including release agents, mold-making material, and anything that might be in contact with the object. It's important to know how a mold or cast is going to be made because the material used to make a mold comes into direct contact with the specimen and the process directly affects the specimen. Some mold-making materials have been known to affect dating techniques. Latex molds have a finite life and will degrade and become unstable due to inherent vice. Repeated use of a specimen to create molds causes deterioration. Limit or deny access for molding or casting purposes if you determine that the process or materials will damage the specimen.

You should consult with the regional/SO curator, a conservator, and a park or local paleontologist or archeologist before authorizing a request to make a whole or partial cast of a NPS specimen.

7. *How do I mark and label the reproduction?* All reproductions done under reproduction agreement with the NPS must be clearly and indelibly identified as such to avoid any confusion with the original.

Permanently mark each reproduction with “NPS Reproduction” or “National Park Service Reproduction.”

If the reproduction is individually made, the artisan or craftsperson’s name and the date should be engraved, incised, or stamped on it in small characters in an unobtrusive but visible location. Casts and molds should be permanently marked as reproductions. This will ensure that the public, researchers, and museum staff won’t confuse the original with the reproduction.

8. *What should I do if an inappropriate reproduction is being made or marketed?* If you have a reproduction agreement with the reproducer and the reproduction isn’t accurate or adequately reproduced, insist on compliance in accordance with the terms of the agreement. Notify the reproducer in writing and require the problems be addressed. If you still aren’t satisfied, consult with the regional/SO curator and the NPS solicitor.

If you don’t have an agreement and the reproducer makes inappropriate claims, such as NPS endorsement of the reproduction, the NPS does have recourse. If this is the case, contact the regional/SO curator and the NPS solicitor for guidance on how to proceed.

H. Selected Glossary

Copyright: The Copyright Act of 1976 grants creators (for example, authors, artists, and architects) exclusive rights to their works, from the moment the work is in fixed form. Copyrights are a bundle of rights given to creators, including the economic rights to: reproduce the work, distribute copies by sale or transfer of ownership, publicly perform the work, prepare derivative works, and publicly display the works. While copyright is not available for any work of the U.S. Government, the Government can receive and hold copyrights transferred to it by third parties. A copyright-protected work can be designated by the “©” symbol. For additional information on copyright and visual artists’ rights refer to Chapter 2, Section C, Copyright Laws.

Licensing: Licensing is the formal granting of permission by the owner of an intellectual property right (“the licensor”) to another party (“the licensee”) to use the intellectual property, subject to certain terms and conditions. At present, the NPS doesn’t have licensing authority.

Patent: A patent is a grant given by the federal government to protect an invention. It gives the patent holder the exclusive right to exclude others from making, using, and selling the invention as defined in the claim. A patent gives the holder 14-year exclusive rights from the date of issue on a design invention, and 20-year exclusive rights from the date of filing for a utility invention. In order to use the patented invention, you have to get the patent holder’s permission. The U.S. Patent and Trademark Office reviews applications and issues patents.

Registration: Federal law provides that marks in use may be registered with the U.S. Patent and Trademark Office and/or with the U.S. Copyright Office. Registration provides additional rights beyond those that would be available

under the common law, such as jurisdiction in federal courts for infringement claims, greater damages and attorney fees, a presumption of ownership and validity, and rights in a greater geographical area.

Trademark (or Servicemark): A trademark is a word, name, logo, symbol, or device, or any combination thereof that is used to identify and distinguish the goods of one person from goods manufactured or sold by others and to indicate the source of the goods. Servicemarks are the same thing as trademarks except that they identify and distinguish services rather than products, such as real estate or consulting services. Marks may be licensed and assigned with certain caveats. A mark can only be assigned together with the goods of the business that is symbolized by the mark, for example clothing and perfumes associated with Chanel. When licensing others to use the mark, the owner must take measures to ensure that the licensee’s products or services retain the characteristics and level of quality that the public has come to associate with the mark. Marks are protected under state common law (designated by a “™”) and through federal registration (designated by a “®”) at the U.S. Patent and Trademark office.

I. Selected Bibliography

Battersby, Gregory J. *The Toy & Game Inventor’s Guide*. Stamford, Conn.: Kent Press, 1996.

Henry Francis du Pont Winterthur Museum, Inc. *Requirements for Licensees, Specifications for Winterthur Products, and the Product Development Process*. Winterthur, Del.: Marketing Division, Henry Francis du Pont Winterthur Museum, Inc., 1990.

Moore, Marilyn. *A Guide to Licensing Artwork*. Stamford, Conn.: Kent Press, 1996.

Museum Store Association Magazine. Denver, Colo.

Revoyr, Jack. *A Primer on Licensing*. Stamford, Conn.: Kent Press, 1995.

Theobald, Mary Miley. *Museum Store Management*. Nashville, Tenn.: American Association for State and Local History, 1991.

Thomas Jefferson Memorial Foundation License Agreement. No date.

J. List of Figures

Figure 5.1. Sample Wording to Include in a Contract between the NPS and a Contractor when a Reproduction is to be Made for In-house Use.....	5:25
Figure 5.2. Sample Wording to Include in an Agreement Authorizing the Park Cooperating Association to Produce Three-dimensional Reproductions on Behalf of the Park.....	5:27
Figure 5.3. Sample Wording to Include in an Agreement between the Park and an Organization to Produce a Three-dimensional Reproduction for Sale and Distribution.....	5:31
Figure 5.4. Sample Wording to Include in a Contract between the Park and a Contractor to Produce a Three-dimensional Reproduction for Sale and Distribution.....	5:35

Figure 5.1. Sample Wording to Include in a Contract between the NPS and a Contractor when a Reproduction is to be Made for In-house Use. *Work with the park contracting officer to incorporate this wording into a contract.*

SAMPLE WORDING
to include in a contract between the
NATIONAL PARK SERVICE
and a
CONTRACTOR

This Contract is made and entered into between the _____(Park name), National Park Service, U.S. Department of the Interior, _____(address), hereafter referred to as "Park" and _____(Contractor), _____(address), referred to hereafter as "Contractor."

PURPOSE:

The Contractor will produce a reproduction of an object or specimen from the Park museum collection to be used in the Park's exhibition, interpretation, and education programs. The _____(reproduction, cast, adaptation, interpretation, or creation) that is made of _____(object or specimen), _____(catalog number) from the Park museum collections, or that is developed from specifications provided by Park will be produced exclusively for the Park.

WITH REGARD to the reproduction produced by Contractor for the Park, the undersigned Contractor agrees that the Contractor can't make additional reproductions of the object without the written permission of the Park. The Park is the sole judge of whether the reproduction meets the standards and specifications required by the Park. See attached specifications. Any copyrights of said reproductions will be the sole property of the NPS.

1. MANNER OF REPRODUCTION

- (a) The Park will provide the Contractor with photographs, dimensions, weight, and reasonable access to the objects, subject to the Park's access procedures outlined in the *Museum Handbook*, Part III, Museum Collections Use. The Park will permit the Contractor to make molds, casts, photographs, negatives, and drawings and to use other reasonable methods to reproduce in the Park's workroom or at such other place(s) as may be agreed upon by the parties.
- (b) The Contractor will pay all costs of making any molds, casts, photographs, negatives, or drawings, or using any other method of reproducing or adapting any object. This includes, but isn't limited to the cost of all materials, machinery, equipment, labor, services, and other expenses, including employees of the Park if needed and used, unless otherwise agreed to in writing.
- (c) The Contractor will ensure that due care is taken in reproducing and adapting any objects to protect and safeguard such works from damage, defacement, destruction, or any acts of the Contractor's employees or agents.
- (d) The Contractor will obtain or arrange to obtain, written permission to reproduce the item from the patent, trademark and license holder(s).
- (e) The Contractor will indemnify or arrange to indemnify the Park and hold it harmless from and against all loss and damage to the objects suffered or incurred.
WHEREAS, the Park is willing to cooperate in the reproduction of such works and to grant the Contractor the right to use the name approved by the Park, the said policy of insurance shall be delivered to the Park before any objects or specimens are delivered to the Contractor and before the start of any copying, reproduction, photographing or any other authorized use.
- (f) The Contractor will pay insurance costs unless otherwise agreed to in writing. The Park, at its sole discretion, will select the form and type of insurance, amount of coverage, and the insurance carrier. The said policy of insurance shall be delivered to the Park before any objects are delivered to the Contractor and before the start of any copying, reproduction, photographing or any other authorized use by the Contractor.
- (g) In the event that one or more of the objects is removed from the Park by the Contractor to a place(s) agreed upon by the parties, all expenses of transportation, packing, mailing and insuring each object will be paid for by the Contractor unless otherwise agreed to in writing.

2. QUALITY CONTROL

- (a) A “to-scale” model or drawing of each reproduction will be submitted to the Park for its written approval prior to its manufacture. The Park may, at its sole discretion, refuse to approve any model or drawing. [Optional: The Park will not approve a reproduction that weighs the same as the original object or specimen].
- (b) If the Park approves the model or drawing the Contractor will make every effort to ensure that the reproduction conforms to the approved model or drawing. The Park and its agents or employees will be permitted at any time(s) during normal business hours to inspect the process and the reproduction. If the Park determines in its sole discretion that any reproduction doesn’t conform to the approved model or drawing, at the request of the Park, the Contractor will modify the reproduction to the Park’s satisfaction, or shall cancel or destroy the same in a manner satisfactory to the Park.

3. TERMINATION

- (a) This Contract is binding on the two parties for the period noted below. The Contractor will deliver a completed reproduction to the Park, subject to the Park’s approval and acceptance, no later than the termination date of this Contract.
- (b) On termination of this Contract all molds, casts, photographs, drawings, negatives, and other methods developed or used by the Contractor to make the reproduction of any objects will be disposed of in a manner satisfactory to the Park or returned to the Park.
- (c) In the event that the Park or the Contractor breaches any material terms or conditions of the Contract and fails to cure said breach within fourteen (14) days after written notice of such breach from the other party, this Contract may be cancelled by the other party. In the event of such cancellation, the parties shall have no further obligations under this Contract other than those, if any, which have accrued as to the termination date.
- (d) The Contractor can’t use the fact that he or she is a supplier for the NPS and the Park in any printed or electronic format without written permission of the NPS.

4. MARKING AND LABELING

- (a) The Contractor must clearly and permanently mark each reproduction, including casts and molds with a “National Park Service Reproduction” or if there is not sufficient space, “NPS Reproduction.”
- (b) The maker’s name must be engraved, incised, or stamped on the reproduction in small characters in an unobtrusive but visible location.

5. TERM

Contract initiation date: _____ Contract termination date: _____

6. SPECIFICATIONS

See attached specifications (provided by the park).

Figure 5.2. Sample Wording to Include in an Agreement Authorizing the Park Cooperating Association to Produce Three-dimensional Reproductions on Behalf of the Park. *Work with the park contracting officer to incorporate this wording into a contract.*

**SAMPLE WORDING
to include in a
THREE-DIMENSIONAL REPRODUCTION
AGREEMENT
with the
PARK COOPERATING ASSOCIATION**

This Agreement is made and entered into between the _____ (Park Name) "Park", National Park Service, U.S. Department of the Interior, _____ (Address), hereafter referred to as "Park", and the _____ (Cooperating Association), _____ (Address), hereafter referred to as "Cooperating Association."

BACKGROUND AND OBJECTIVES

The Park will increase access to National Park Service (NPS) museum collections and enhance the NPS goals of preservation, education, interpretation, and research by developing reproductions of NPS museum collections.

The Agreement authorizes the Cooperating Association to enter into agreements with third parties to develop park museum reproductions for sale and distribution. The agreement establishes terms and conditions that the Cooperating Association must include in all agreements between the Cooperating Association and third parties.

AUTHORITY

The following statutory authorities provide the legal basis for the NPS to enter into this agreement:

Organic Act of 1916, 16 USC 1 et seq.

Historic Sites Act of 1935, 16 USC 461-467, as amended

Museum Properties Management Act of 1955, 16 USC 18(f), as amended

Director's Order #32: Cooperating Associations

Director's Order #21: Donations and Fundraising

NPS Cooperative Agreement Authority (February 2, 1998)

Omnibus Consolidated Appropriations Act of 1997, PL 104e-208 (September 30, 1996), Title I, National Park Service, Administrative Provisions allows the NPS to *enter into cooperative agreements...for the purpose of carrying out NPS programs...*

STATEMENT OF WORK

The Park authorizes the Park Cooperating Association to manufacture and/or distribute reproductions of _____ (Objects/Specimens) described in _____ (Attachment) in accordance with terms and conditions outlined in this Agreement.

NOW THEREFORE, in consideration of the mutual promises set forth herein, the parties agree:

WHEREAS, the Cooperating Association is engaged in managing the manufacture of reproductions, adaptations, interpretations, creations, scale models, and casts of original museum objects and specimens, henceforth referred to as reproductions, and in the distribution and sale of such reproductions. It is mutually agreed as follows:

1. PROCEDURES FOR THE COOPERATING ASSOCIATION TO ENTER INTO THIRD PARTY AGREEMENTS

The Park agrees to allow the Cooperating Association to reproduce or arrange to reproduce, selected objects from the Park museum collections.

The Cooperating Association will seek written approval from the Park of all requests to make three-dimensional museum reproductions. The Park will provide written approval of the contractor/organization(s) selected to manufacture and distribute three-dimensional reproductions of Park museum objects and specimens. Upon Park approval, the Cooperating Association will enter into a separate agreement with the third party that includes all the

terms and conditions outlined in this Contract. The Cooperating Association and the third party will abide by all terms and conditions noted below.

2. NON-EXCLUSIVE RIGHTS

- (a) Subject to conditions set forth herein, the Park grants to the Cooperating Association and the approved organization/contractor(s) the non-exclusive, personal, and non-assignable right for the term of this Agreement to use the Park's name on the reproductions as well as in labeling, advertising, and promoting works from the Park's collections as noted in _____(Attachment). This right is granted on such other and additional works, if any, as the parties hereto from time to time agree upon in writing.
- (b) The Park grants to the Cooperating Association and the approved organization/contractor the non-exclusive right during the term of this Agreement to make or cause to be made, reproductions of Park objects or specimens that will be sold throughout the USA.

3. MANNER OF REPRODUCTION

- (a) The Park will provide the Cooperating Association and approved organization/contractor, with photographs, dimensions, weight, and reasonable access to the object or specimen, subject to the Park's access procedures outlined in the *Museum Handbook*, Part III, Museum Collections Use. The Park will permit the Cooperating Association and the organization/contractor to make molds, casts, photographs, negatives, and drawings and to use other reasonable methods to reproduce in the Park's workroom or at such other place(s) as may be agreed upon by the parties.
- (b) The Cooperating Association will pay or arrange to have paid, all costs of making any molds, casts, photographs, negatives, or drawings, or using any other method of reproducing or adapting any object. This includes, but isn't limited to the cost of all materials, machinery, equipment, labor, including employees of the Park if needed and used, services, insurance and other expenses.
- (c) The Cooperating Association will obtain or arrange to obtain, written permission to reproduce the item from the patent, trademark and license holder(s).
- (d) The Cooperating Association will ensure that due care is taken in reproducing and adapting any objects to protect and safeguard such works from damage, defacement, destruction, or any acts of its employees or agents.
- (e) The Cooperating Association will indemnify or arrange to indemnify the Park and hold it harmless from and against all loss and damage to the objects suffered or incurred, and adaptations as well as in labeling, advertising, and promoting the sale of such reproductions.
WHEREAS, the Park is willing to cooperate in the reproduction of such works and to grant the Cooperating Association or approved organization/contractor the right to use the name approved by the Park, the said policy of insurance shall be delivered to the Park before any objects or specimens are delivered to the approved organization/contractor and before the start of any copying, reproduction, photographing or any other authorized use.
- (f) The Cooperating Association or approved organization/contractor will pay insurance costs, unless otherwise agreed to in writing. The Park, at its sole discretion will select the form and type of insurance, amount of coverage, and the insurance carrier. The said policy of insurance shall be delivered to the Park before any objects are delivered to the Cooperating Association or approved organization/contractor.
- (g) In the event that one or more of the objects is removed from the Park by the Cooperating Association or approved organization/contractor to a place(s) agreed upon by the parties, all expenses of transportation, packing, mailing and insuring each object will be paid for by the Cooperating Association or approved organization/contractor, unless otherwise agreed to in writing.

4. QUALITY CONTROL

- (a) A prototype of each reproduction will be submitted to the Park for its written approval prior to its manufacture or sale. The Park may, at its sole discretion, refuse to approve any prototype. In this case the Cooperating Association or approved organization/contractor will not manufacture or sell such reproduction, and will cancel or destroy the same in a manner satisfactory to the Park. [Optional: The Park will not approve a prototype that weighs the same as the object or specimen.]
- (b) If the Park approves a prototype in writing, the Cooperating Association will make every effort to ensure that all reproductions conform to the approved prototype. The Park and its agents or employees will be permitted at any time(s) during normal business hours to examine production-line reproductions. If the Park determines in its sole discretion that any reproduction doesn't conform to its approved prototype, at the request of the Park, the

Cooperating Association will make sure that the organization/contractor shall refrain from manufacturing or selling such reproduction and shall cancel or destroy the same in a manner satisfactory to the Park.

- (c) The Cooperating Association will arrange to hand deliver or send by certified mail, to the Park, all advertising copy, promotional material and packaging to be used in connection with the sale or offering for sale of any reproduction. The Cooperating Association will ensure that the approved organization/contractor won't use any such copy, material or packaging unless and until approved in writing by the Park.
- (d) The Cooperating Association must make sure that all reproductions display advertising, labeling or other promotional material that indicate said reproductions are derived or copied from original works, objects or specimens in the Park museum collection. The Park must approve all copy in writing.
- (e) All reproductions must be marked with "National Park Service Reproduction" or if there is insufficient space, "NPS Reproduction" in a permanent impressed or incised mark.
- (f) A brief description and history of the original work or specimen, as described in the *Museum Handbook*, Part III, Chapter 5, Section C, Reproductions by NPS or under NPS Agreement, must be attached to each reproduction. The description should also refer to the weight of the original object or specimen. The Park will provide a description and history for each object.
- (g) The Cooperating Association will provide the Park with ___ copy(ies) of each reproduction of each object without charge.
- (h) The Cooperating Association will limit the number of reproductions to _____ (maximum) for the initial production quantity of each reproduction. All parties will agree, in writing, to the production of subsequent quantities.
- (i) During the term of this Agreement, any copyrights of said reproductions will be the sole property of the Cooperating Association. At the termination of this Agreement, all copyrights shall be assigned to the Park at no cost and free and clear of any lien or encumbrance.

5. BENEFITS

The Cooperating Association will convey benefits to the Park resulting from this activity in accordance with NPS *Cooperating Association Guideline*. Financial arrangements between the Cooperating Association and the third party must be developed independently of the Park.

6. TERMINATION

- (a) This Agreement is binding on the Park and the Cooperating Association for a period of three (3) years from the date first noted above. It will be renewed automatically for successive terms of one (1) year each year thereafter, unless terminated. Each party must notify the other in writing, of its intention to terminate this Agreement at the end of the current year. The termination notice must be received at least three (3) months prior to the end of the original termination of this Agreement or prior to the end of any said one (1) year renewal period.
- (b) On termination of this Agreement, all molds, casts, photographs, drawings, negatives, and other products developed or used by the Cooperating Association and selected organization/contractor to make said reproductions of objects or specimens shall be destroyed in a manner satisfactory to the Park or returned to the Park.
- (c) On termination of this Agreement, the Cooperating Association will use all reasonable efforts to avoid having an excessive inventory of reproductions on hand, and/or work in progress. Any work in progress on such termination, may be completed and sold by the Cooperating Association, provided this is done within _____ months after said termination date.
- (d) In the event that the Park or the Cooperating Association breaches any material terms or conditions of the Agreement and fails to cure said breach within fourteen (14) days after written notice of such breach, this Agreement may be cancelled by the other party. In the event of such cancellation, the parties shall have no further obligations under this Agreement other than those, if any, which have accrued as to the termination date. The Cooperating Association shall have no further right to manufacture or sell reproductions of the objects or specimens or to use the Park's name, except as provided herein.

7. LIABILITY

The Cooperating Association shall arrange to:

- (a) Pay the full value of all damages to the property of the United States caused by the organization, its representatives, or employees; and

- (b) Indemnify, save and hold harmless, and defend the United States against all fines, claims, damages, losses, judgments, and expenses arising out of, or from, any omission or activity of such organization, its representative, or employees.
- (c) Indemnify, save and hold harmless the United States against all fines, claims, damages, losses, judgments, and expenses arising out of, or from, any omission or activity of the manufacture, sale, and use of the reproduction(s).
- (d) Provide the NPS with certification of public and employee liability insurance coverage.

8. NOTICE

Any notice or demand relating to this Agreement must be made in writing and delivered to all parties. Delivery will be made to the respective addresses as specified herein unless such address has been changed by notice to the other party in writing.

9. ASSIGNMENT

This Agreement is personal to the Cooperating Association. It may not be assigned or otherwise transferred in any manner by operation or law or otherwise without the prior written consent of the Park. Consent is given or withheld at the Park's sole discretion.

10. MODIFICATION

This Agreement may not be modified or altered except in a written document signed by both parties.

11. PAROL EVIDENCE

This document contains the entire Agreement between parties. No statement, negotiation, promise, or inducement made by any party or any agent of any party that isn't included in this Agreement is valid or binding. Wherever possible each provision of this Agreement will be interpreted in such manner as to be effective and valid under applicable law. If any provision of this Agreement is prohibited or invalid under applicable law, such provision(s) will be ineffective to the extent of such prohibition or invalidity without invalidating the remaining provisions of this Agreement.

12. KEY OFFICIALS

For the NPS:

For the purposes of direction in contractual interpretation matters, contract coordination, daily operational matters, dispute resolution, or for modification to this Agreement, NPS shall be represented by the Superintendent, _____ (Park), _____ (Address, Telephone, and Facsimile).

For the Cooperating Association:

For purposes of liaison and direction in daily operational matters, Cooperating Association will be represented by _____ (Responsible official, Cooperating Association), _____ (Address, Telephone, and Facsimile).

All notices shall be given by U.S. certified mail, postage prepaid, to the above representatives at their indicated addresses.

IN WITNESS WHEREOF, the parties hereto have executed this Agreement on the day and year first written above.

Superintendent

(Name) _____ Signature: _____

Cooperating Association (Responsible Official):

(Name): _____ Signature: _____

Date: _____

Figure 5.3. Sample Wording to include in an Agreement between the Park and an Organization to Produce a Three-dimensional Reproduction for Sale and Distribution.

**SAMPLE WORDING
to include in a
THREE-DIMENSIONAL REPRODUCTION
AGREEMENT
between the
PARK
and an
ORGANIZATION**

This Agreement is made and entered into between the _____ (Park), National Park Service, U.S. Department of the Interior, _____ (address), hereafter referred to as "Park" and the _____ (Organization), _____ (address), hereafter referred to as "Cooperator."

BACKGROUND AND OBJECTIVES

The Park enters into an Agreement with the Cooperator to develop three-dimensional reproductions from the Park museum collections for sale and distribution. Three-dimensional reproductions enhance NPS goals of preservation, interpretation, and research by increasing access to the Park's museum collections.

AUTHORITY

The following statutory authorities provide the legal basis for the Park to enter into this agreement:

Organic Act of 1916, 16 USC 1 et seq.
Historic Sites Act of 1935, 16 USC. 461-467, as amended
Museum Properties Management Act of 1955, 16 USC 18(f), as amended
Director's Order #32: Cooperating Associations
Director's Order #21: Donations and Fundraising
NPS Cooperative Agreement Authority (February 2, 1998)
Omnibus Consolidated Appropriations Act of 1997, PL 104e-208 (September 30, 1996), Title I, National Park Service, Administrative Provisions allows the NPS to *enter into cooperative agreements...for the purpose of carrying out NPS programs...*

STATEMENT OF WORK

The Park authorizes the Cooperator to manufacture and/or distribute reproductions of _____ (Objects/Specimens) described in _____ (Attachment) in accordance with terms and conditions outlined in this Agreement.

NOW THEREFORE, in consideration of the mutual promises set forth herein, the parties agree:

The Cooperator is engaged in the making of reproductions, adaptations, interpretations, creations, scale models, and casts of original museum objects and specimens, henceforth referred to as reproductions, and in the distribution and sale of such reproductions. It is mutually agreed as follows:

1. NON-EXCLUSIVE RIGHTS

- (a) Subject to conditions set forth herein, the Park grants to the Cooperator the non-exclusive, personal, and non-assignable right for the term of this Agreement to use the Park's name on the reproductions as well as in labeling, advertising, and promoting works from the Park's collections as noted in _____ (Attachment). This right is granted on such other and additional objects or specimens, if any, as the parties hereto from time to time agree upon in writing.
- (b) The Park grants to the Cooperator the non-exclusive right for the period of _____ years, starting _____ and ending _____, to make or cause to be made, reproductions of Park objects or specimens that will be sold throughout the USA.

2. MANNER OF REPRODUCTION

- (a) The Park will provide the Cooperator with photographs, dimensions, weight, and reasonable access to the object or specimen, subject to the Park's access procedures outlined in the *Museum Handbook*, Part III, Museum Collections Use. The Park will permit the Cooperator to make molds, casts, photographs, negatives, and drawings and to use other reasonable methods to reproduce in the Park's workroom or at such other place(s) as may be agreed upon by the parties.
- (b) The Cooperator will pay all costs of making any molds, casts, photographs, negatives, drawings, or using any other method of reproducing or adapting any object. This includes, but isn't limited to the cost of all materials, machinery, equipment, labor, including employees of the Park if needed, services, insurance and other expenses.
- (c) The Cooperator will obtain written permission to reproduce the item from the patent, trademark and license holder(s).
- (d) The Cooperator will use due care in reproducing and adapting any objects to protect and safeguard such works from damage, defacement, destruction, or any acts of its employees or agents.
- (e) The Cooperator will indemnify the Park and hold it harmless from and against all loss and damage related to the reproductions, as well as in the labeling, advertising, and promoting of the sale of such reproductions. WHEREAS, the Park is willing to cooperate in the reproduction of such works and to grant the Cooperator the right to use the name approved by the Park, the said policy of insurance shall be delivered to the Park before any objects or specimens are delivered to the Cooperator and before the start of any copying, reproduction, photographing or any other authorized use by the Cooperator.
- (f) The Cooperator will pay insurance costs unless agreed to in writing. The Park, at its sole discretion will select the form and type of insurance, amount of coverage and the insurance carrier. The said policy of insurance shall be delivered to the Park before any objects are delivered to the Cooperator.
- (g) In the event that one or more of the objects is removed from the Park by the Cooperator to a place(s) agreed upon by the parties, all expenses of transportation, packing, mailing and insuring each object will be paid for by the Cooperator unless otherwise agreed to in writing.

3. QUALITY CONTROL

- (a) A prototype of each reproduction will be submitted to the Park for its written approval prior to its manufacture or sale. The Park may, at its sole discretion, refuse to approve any prototype. In this case the Cooperator will not manufacture or sell such reproduction, and will cancel or destroy the same in a manner satisfactory to the Park. [Optional: The Park will not approve a prototype that weighs the same as the object or specimen].
- (b) If the Park approves a prototype in writing, the Cooperator will make every effort to ensure that all reproductions conform to the approved prototype. The Park and its agents or employees will be permitted at any time(s) during normal business hours to examine production-line reproductions. If the Park determines in its sole discretion that any reproduction doesn't conform to its approved prototype, at the request of the Park, the Cooperator shall refrain from manufacturing or selling such reproduction and shall cancel or destroy the same in a manner satisfactory to the Park.
- (c) The Cooperator will hand deliver or send by certified mail, to the Park, all advertising copy, promotional material and packaging to be used in connection with the sale or offering for sale of any reproduction. The Cooperator won't use any such copy, material, or packaging unless and until approved in writing by the Park.
- (d) The Cooperator must display on all reproductions it makes, all advertising, labeling or other promotional material that said reproductions are derived or copied from original works, objects or specimens in the Park museum collection. The Park must approve all copy in writing.
- (e) All reproductions must be marked with "National Park Service Reproduction" or if there is insufficient space, "NPS Reproduction" in a permanent impressed or incised mark.
- (f) A brief description and history of the original work or specimen as described in the *Museum Handbook*, Part III, Chapter 5, Section C, Reproductions by NPS or under NPS Agreement must be attached to each reproduction. The description should also refer to the weight of the original object or specimen. The Park will provide a description and history for each object.
- (g) The Cooperator will provide the Park with ___ copy(ies) of each reproduction of each object without charge.
- (h) For the initial production quantity, the Cooperator will limit the number of reproductions to _____(maximum), for each object or specimen to be reproduced. Both parties will agree in writing to subsequent quantities.
- (i) During the term of this Agreement, any copyrights of said reproductions will be the sole property of the Cooperator. At the termination of this Agreement, all copyrights shall be assigned to the Park at no cost, and free and clear of any lien or encumbrance.

4. COST RECOVERY

The Park, in accordance with the Special Use Permit, will calculate recovery costs for the following activities: identifying the object(s) and specimen(s); locating documentation in accession and catalog folders; measuring and preparing the object; conserving the object; supervising contractor access; doing photography; purchasing materials and equipment, if appropriate; transporting item to vendor/contractor; overseeing the contractor or manufacturer; inspecting the prototype; controlling quality during production; packaging and mailing; producing captions and credits; and completing all necessary paperwork.

The Cooperator will transmit funds to cover all costs incurred by the Park in accordance with Director's Order #32.

5. TERMINATION

- (a) This Agreement is binding on the Park and the Cooperator for a period of three (3) years from the date first noted above. It will be renewed automatically for successive terms of one (1) year each year thereafter, unless terminated. Each party must notify the other in writing, of its intention to terminate this Agreement at the end of the current year. The termination notice must be received at least three (3) months prior to the end of the original termination of this Agreement or prior to the end of any said one (1) year renewal period.
- (b) On termination of this Agreement, all molds, casts, photographs, drawings, negatives, and other products developed or used by the Cooperator to make said reproductions of any objects or specimens shall be destroyed in a manner satisfactory to the Park or returned to the Park.
- (c) On termination of this Agreement, the Cooperator will use all reasonable efforts to avoid having an excessive inventory of reproduction on hand, and/or work in progress. Any work in progress on such termination, may be completed and sold by the Cooperator, provided this is done within _____ months after said termination date. All reproductions on hand as of the termination date will first be offered to the Park or the Park Cooperating Association at prices and discounts applicable to sales to the Park and the Park Cooperating Association.
- (d) In the event that the Park or the Cooperator breaches any material terms or conditions of the Agreement and fails to cure said breach within fourteen (14) days after written notice of such breach, this Agreement may be cancelled by the other party. In the event of such cancellation, the parties shall have no further obligations under this Agreement other than those, if any, which have accrued as to the termination date. The Cooperator shall have no further right to manufacture or sell reproductions of the objects or specimens or to use the Park's name, except as provided herein.
- (e) If the Cooperator files a petition under any federal or state bankruptcy or insolvency law seeking reorganization, arrangement or any relief there under, or a petition is filed against the Cooperator under any federal or state bankruptcy law; and such a petition isn't dismissed within in thirty (30) days after filing thereof, or the Cooperator makes an assignment for the benefit of creditors or seeks or consents to the appointment of a receiver, or a receiver is appointed for the Cooperator or its property and such appointment is not vacated within thirty (30) days after, or the Cooperator sells or otherwise transfers all or substantially all of its assets or business, or merges or consolidates with any other corporation or other entity or the management control of Cooperator is changed by whatever means, then this Agreement shall terminate automatically. The Cooperator will return all casts, molds, negatives, drawings, photographs, and other products of reproducing any object or specimen to the Park. The Cooperator will offer Park or the Cooperating Association all inventory of reproductions of objects or specimens then on hand at a price equal to the Cooperator's out of pocket costs incurred in connection with the production thereof. No trustee, receiver, assignee, transferee, or successor of the Cooperator shall have any rights under this Agreement.

6. LIABILITY

The Cooperator shall:

- (a) Pay the United States the full value of all damages to the property of the United States caused by such an organization, its representatives, or employees; and
- (b) Indemnify, save and hold harmless, and defend the United States against all fines, claims, damages, losses, judgements, and expenses arising out of, or from, any omission or activity of such organization, its representative, or employees.
- (c) Indemnify, save and hold harmless the United States against all fines, claims, damages, losses, judgements, and expenses arising out of, or from, any omission or activity of the manufacture, sale, and use of the reproduction(s).
- (d) Provide the NPS with certification of public and employee liability insurance coverage.

7. NOTICE

Any notice or demand relating to this Agreement must be made in writing and delivered to both parties. Delivery will be made to the respective addresses as specified herein unless such address has been changed by notice to the other party in writing.

8. ASSIGNMENT

This Agreement is personal to the Cooperator. It may not be assigned or otherwise transferred in any manner by operation of law or otherwise without the prior written consent of the Park. Consent is given or withheld at the Park's sole discretion.

9. MODIFICATION

This Agreement may not be modified or altered except in a written document signed by both parties.

10. PAROL EVIDENCE

This document contains the entire Agreement between parties. No statement, negotiation, promise, or inducement made by any party or any agent of any party that isn't included in this Agreement is valid or binding. Wherever possible each provision of this Agreement will be interpreted in such manner as to be effective and valid under applicable law. If any provision of this Agreement is prohibited or invalid under applicable law, such provision(s) will be ineffective to the extent of such prohibition or invalidity without invalidating the remaining provisions of this Agreement.

11. KEY OFFICIALS

For the NPS:

For the purposes of direction in contractual interpretation matters, contract coordination, daily operational matters, dispute resolution, or for modification to this Agreement, NPS shall be represented by the Superintendent, _____ (Park), _____ (Address, Telephone, and Facsimile).

For the Cooperator:

For purposes of liaison and direction in daily operational matters, the Cooperator will be represented by _____ (Responsible official, Cooperator), _____ (Address, Telephone and Facsimile).

All notices shall be given by U.S. certified mail, postage prepaid, to the above representatives at their indicated addresses.

IN WITNESS WHEREOF, the parties hereto have executed this Agreement on the day and year first written above.

Superintendent

(Name) _____ Signature: _____

Date _____

Cooperator (Responsible Official)

(Name) _____ Signature: _____

Date: _____

Figure 5.4. Sample Wording to Include in a Contract between the Park and a Contractor to Produce a Three-dimensional Reproduction for Sale and Distribution.

SAMPLE WORDING
for a
THREE-DIMENSIONAL REPRODUCTION
CONTRACT
between the
PARK
and a
CONTRACTOR

This Contract is made and entered into between the _____ (Park), National Park Service, U.S. Department of the Interior, _____ (address), hereafter referred to as "Park" and the _____ (Contractor), _____ (address), hereafter referred to as "Contractor."

BACKGROUND AND OBJECTIVES

The Park enters into a Contract with the Contractor to develop three-dimensional reproductions from the Park museum collections for sale and distribution. Three-dimensional reproductions enhance NPS goals of preservation, interpretation, and research by increasing access to the Park's museum collections.

AUTHORITY

The following statutory authorities provide the legal basis for the Park to enter into this Contract:

- Organic Act of 1916, 16 USC 1 et seq.
- Historic Sites Act of 1935, 16 USC 461-467, as amended
- Museum Properties Management Act of 1955, 16 USC 18(f), as amended
- Director's Order #32: Cooperating Associations
- Director's Order #21: Donations and Fundraising
- NPS Cooperative Agreement Authority (February 2, 1998)
- Omnibus Consolidated Appropriations Act of 1997, PL 104e-208 (September 30, 1996), Title I, National Park Service, Administrative Provisions allows the NPS to *enter into cooperative agreements...for the purpose of carrying out NPS programs.*

STATEMENT OF WORK

The Park authorizes the Contractor to manufacture and/or distribute reproductions of _____ (Objects/Specimens) described in _____ (Attachment) in accordance with terms and conditions outlined in this Contract.

NOW THEREFORE, in consideration of the mutual promises set forth herein, the parties agree:

The Contractor is engaged in the making of reproductions, adaptations, interpretations, creations, scale models, and casts of original museum objects and specimens, henceforth referred to reproductions, and in the distribution and sale of such reproductions. It is mutually agreed as follows:

1. NON-EXCLUSIVE RIGHTS

- (a) Subject to conditions set forth herein, the Park grants to the Contractor the non-exclusive, personal, and non-assignable right for the term of this Contract to use the Park's name on the reproductions as well as in labeling, advertising, and promoting works from the Park's collections as noted in ____ (Attachment). This right is granted on such other and additional objects or specimens, if any, as the parties hereto from time to time agree upon in writing.
- (b) The Park grants to the Contractor the non-exclusive right for the duration of _____ years, starting _____ and ending _____, to make or cause to be made, reproductions of Park objects or specimens that will be sold throughout the USA.

2. MANNER OF REPRODUCTION

- (a) The Park will provide the Contractor with photographs, dimensions, weight, and reasonable access to the object or specimen, subject to the Park's access procedures outlined in the *Museum Handbook*, Part III, Museum Collections Use. The Park will permit the Contractor to make molds, casts, photographs, negatives, and drawings and to use other reasonable methods to reproduce the object or specimen in the Park's workroom or at such other place(s) as may be agreed upon by the parties.
- (b) The Contractor will pay all costs of making any molds, casts, photographs, negatives, or drawings, or using any other method of reproducing or adapting any object. This includes, but isn't limited to the cost of all materials, machinery, equipment, labor, including employees of the Park if needed and used, services, insurance and other expenses.
- (c) The Contractor will obtain written permission to reproduce the item from the patent, trademark and license holder(s).
- (d) The Contractor will use due care in reproducing and adapting any objects and specimens to protect and safeguard such items from damage, defacement, destruction, or any acts of his or her employees or agents.
- (e) The Contractor will indemnify the Park through an insurance policy and hold the Park harmless from and against all loss and damage to the objects and specimens suffered or incurred, as well as in the labeling, advertising, and promoting of the sale of such reproductions.

WHEREAS, the Park is willing to cooperate in the reproduction of such items and to grant the Contractor the right to use the name approved by the Park, the said policy of insurance shall be delivered to the Park before any objects or specimens are delivered to the Contractor and before the start of any copying, reproduction, photographing or any other authorized use by the Contractor.

- (f) The Contractor will pay insurance costs unless agreed to in writing. The Park, at its sole discretion will select the form and type of insurance, amount of coverage, and the insurance carrier. In the event that one or more of the objects is removed from the Park by the Contractor to a place(s) agreed upon by the parties, all expenses of transportation, packing, mailing, and insuring each object will be paid by the Contractor.
- (g) In the event that one or more of the objects is removed from the Park by the Contractor to a place(s) agreed upon by the parties, all expenses of transportation, packing, mailing and insuring each object will be paid for by the Contractor unless otherwise agreed to in writing

3. QUALITY CONTROL

- (a) A prototype of each reproduction will be submitted to the Park for its written approval prior to its manufacture or sale. The Park may, at its sole discretion, refuse to approve any prototype. In this case the Contractor will not manufacture or sell such reproduction, and will cancel or destroy the same in a manner satisfactory to the Park. [Optional: The Park will not approve a prototype that weighs the same as the object or specimen.]
- (b) If the Park approves a prototype in writing, the Contractor will make every effort to ensure that all reproductions conform to the approved prototype. The Park and its agents or employees will be permitted at any time(s) during normal business hours to examine production-line reproductions. If the Park determines in its sole discretion that any reproduction doesn't conform to its approved prototype, at the request of the Park, the Contractor shall refrain from manufacturing or selling such reproduction and shall cancel or destroy the same in a manner satisfactory to the Park.
- (c) The Contractor will hand deliver or send by certified mail, to the Park, all advertising copy, promotional material and packaging to be used in connection with the sale or offering for sale of any reproduction. The Contractor won't use any such copy, material, or packaging unless and until approved in writing by the Park.
- (d) The Contractor must display on all reproductions it makes, all advertising, labeling or other promotional material that said reproductions are derived or copied from original works, objects or specimens in the Park museum collection. The Park must approve all copy in writing.
- (e) All reproductions must be marked with "National Park Service Reproduction" or if there is insufficient space, "NPS Reproduction" in a permanent impressed or incised mark.
- (f) A brief description and history of the original work or specimen, as described in the *Museum Handbook*, Part III, Chapter 5, Section C, Reproductions by NPS or under NPS Contract, must be attached to each reproduction. The description should also refer to the weight of the original object or specimen. The Park will provide a description and history for each object.
- (g) The Contractor will provide the Park with ___ copy(ies) of each reproduction of each object without charge.
- (h) For the initial production quantity, the Contractor will limit the number of reproductions to _____(maximum) for each object or specimen to be reproduced. Both parties will agree in writing to subsequent quantities.

- (i) During the term of this Contract, any copyrights of said reproductions will be the sole property of the Contractor. At the termination of this Contract, all copyrights shall be assigned to the Park at no cost, and free and clear of any lien or encumbrance.

4. COST RECOVERY

The Park, in accordance with the Special Use Permit, will calculate recovery costs for the following activities: identifying the object(s) and specimen(s); locating documentation in accession and catalog folders; measuring and preparing the object; conserving the object; supervising contractor access; doing photography; purchasing materials and equipment, if appropriate; transporting item to vendor/contractor; overseeing the contractor or manufacturer; inspecting the prototype; controlling quality during production; packaging and mailing; producing captions and credits; and completing all necessary paperwork.

The Contractor will transmit funds to cover all costs incurred by the Park in accordance with Director's Order #32.

5. TERMINATION

- (a) This Contract is binding on the Park and the Contractor for a period of three (3) years from the date first noted above. It will be renewed automatically for successive terms of one (1) year each year thereafter, unless terminated. Each party must notify the other in writing, of its intention to terminate this Contract at the end of the current year. The termination notice must be received at least three (3) months prior to the end of the original termination of this Contract or prior to the end of any said one (1) year renewal period.
- (b) On termination of this Contract, all molds, casts, photographs, drawings, negatives, and other products developed or used by the Contractor to make said reproductions of any objects or specimens shall be destroyed in a manner satisfactory to the Park or returned to the Park.
- (c) On termination of this Contract, the Contractor will use all reasonable efforts to avoid having an excessive inventory of reproduction on hand, and/or work in progress. Any work in progress on such termination, may be completed and sold by the Contractor, provided this is done within _____ months after said termination date. All reproductions on hand as of the termination date will first be offered to the Park or the Park Cooperating Association at prices and discounts applicable to sales to the Park and the Park Cooperating Association.
- (d) In the event that the Park or the Contractor breaches any material terms or conditions of the Contract and fails to cure said breach within fourteen (14) days after written notice of such breach, this Contract may be cancelled by the other party. In the event of such cancellation, the parties shall have no further obligations under this Contract other than those, if any, which have accrued as to the termination date. The Contractor shall have no further right to manufacture or sell reproductions of the objects or specimens or to use the Park's name, except as provided herein.
- (e) If the Contractor files a petition under any federal or state bankruptcy or insolvency law seeking reorganization, arrangement or any relief thereunder, or a petition is filed against the Contractor under any federal or state bankruptcy law; and such a petition isn't dismissed within in thirty (30) days after filing thereof, or the Contractor makes an assignment for the benefit of creditors or seeks or consents to the appointment of a receiver, or a receiver is appointed for the Contractor or its property and such appointment is not vacated within thirty (30) days after, or the Contractor sells or otherwise transfers all or substantially all of its assets or business, or merges or consolidates with any other corporation or other entity or the management control of Contractor is changed by whatever means, then this Contract shall terminate automatically. The Contractor will return all casts, molds, negatives, drawings, photographs, and other products of reproducing any object or specimen to the Park. The Contractor will offer the Cooperating Association all inventory of reproductions of objects or specimens then on hand at a price equal to the Contractor's out of pocket costs incurred in connection with the production thereof. No trustee, receiver, assignee, transferee, or successor of the Contractor shall have any rights under this Contract.

6. LIABILITY

The Contractor shall:

- (a) Pay the United States the full value of all damages to the property of the United States caused by such Contractor, his or her representatives, or employees; and
- (b) Indemnify, save and hold harmless, and defend the United States against all fines, claims, damages, losses, judgements, and expenses arising out of, or from, any omission or activity of the Contractor, his or her representative, or employees.

- (c) Indemnify, save, and hold harmless the United States against all fines, claims, damages, losses, judgements, and expenses arising out of, or from, any omission or activity of the manufacture, sale, and use of the reproduction(s).
- (d) Provide the NPS with certification of public and employee liability insurance coverage.

7. NOTICE

Any notice or demand relating to this Contract must be made in writing and delivered to both parties. Delivery will be made to the respective addresses as specified herein unless such address has been changed by notice to the other party in writing.

8. ASSIGNMENT

This Contract is personal to the Contractor. It may not be assigned or otherwise transferred in any manner by operation or law or otherwise without the prior written consent of the Park. Consent is given or withheld at the Park's sole discretion.

9. MODIFICATION

This Contract may not be modified or altered except in a written document signed by both parties.

10. PAROL EVIDENCE

This document contains the entire Contract between parties. No statement, negotiation, promise or inducement made by any party or any agent of any party that isn't included in this Contract is valid or binding.

Wherever possible each provision of this Contract will be interpreted in such manner as to be effective and valid under applicable law. If any provision of this Contract is prohibited or invalid under applicable law, such provision(s) will be ineffective to the extent of such prohibition or invalidity without invalidating the remaining provisions of this Contract.

11. KEY OFFICIALS

For the NPS:

For the purposes of direction in contractual interpretation matters, contract coordination, daily operational matters, dispute resolution, or for modification to this Contract, NPS shall be represented by the Superintendent, _____ (Park), _____ (Address, Telephone, and Facsimile).

For the Contractor:

For purposes of liaison and direction in daily operational matters, the Contractor will be represented by _____ (Responsible individual), _____ (Address, Telephone, and Facsimile).

All notices shall be given by U.S. certified mail, postage prepaid, to the above representatives at their indicated addresses.

IN WITNESS WHEREOF, the parties hereto have executed this Contract on the day and year first written above.

Superintendent

(Name) _____ Signature: _____

Date _____

Contractor

(Name) _____ Signature: _____

Date: _____

Chapter 6: Other Uses of Museum Collections

	<u>Page</u>
A. Overview	6:1
What does this chapter cover?	6:1
What NPS policies and guidelines do I need to know?	6:1
B. Management Concerns	6:2
What management issues must be addressed when dealing with other uses of museum collections?	6:2
What security risks must be considered?	6:3
What preservation issues must I consider?.....	6:3
What visitor and interpretation issues should I consider?	6:5
What is considered a special park use ?.....	6:5
When do you need a special use permit?	6:6
When don't you need a special use permit?.....	6:6
Can I recover costs for other uses of museum collections?.....	6:7
C. General NPS Policy on Filming and Photography	6:8
What NPS policies and guidelines on filming and photography do I need to know?.....	6:8
When is a permit for filming or photography required in the park?.....	6:8
When isn't a permit required for filming and photography in the park?	6:8
D. Filming and Photography in Spaces Housing Museum Collections	6:9
How do NPS policies apply to filming, movie and video production and still photography in spaces housing museum collections?	6:9
What else do I need to know to make a decision about the appropriateness of the use?	6:10
When is a permit required for filming and photography in spaces housing collections?	6:11
When isn't a permit required for filming and photography in spaces housing collections?	6:11
When is a permit optional for filming and photography in spaces housing museum collections?	6:11
What procedures should I implement for filming and photography in areas housing collections?	6:11
How do I maintain control of filming, still photography, videotaping and sound recording projects once the project is completed?	6:12
E. Special Events in and Exhibit and Other Spaces Housing Museum Collections	6:13
What activities are considered special event activities?.....	6:13
Do NPS-sponsored special events require a special use permit?.....	6:14
What NPS policies and guidelines do I need to know?	6:14
Is a special use permit required for a special event?	6:14
How do these policies apply to special events in exhibit and other spaces housing museum collections?	6:14
Can I recover costs for hosting a special event in exhibit spaces?	6:15
What procedures do I need to implement for special events in exhibit spaces?.....	6:16
What special events aren't permitted in spaces that house museum collections?.....	6:17
What issues must I consider about painting and sketching?.....	6:18
F. Museum Objects in Working Order	6:18
Should I keep museum objects in working order?.....	6:18
Do I need a special use permit to keep museum objects in working order?	6:19
Under what circumstances should I keep museum objects in working order?.....	6:19
What kinds of objects may be kept in working order?	6:20
What do I need to consider before allowing objects to be put into working order?	6:20
How do I document an object in operation?	6:21
What conservation and maintenance issues do I need to consider?	6:22

G. Museum Objects Used in Performances, Sound Productions, or Demonstrations	6:23
What kinds of uses are covered in this section?	6:23
What kinds of objects are used in performances, sound productions, or demonstrations?	6:23
Should I allow objects to be used in performances, sound productions, or demonstrations?	6:24
What issues do I consider for objects in performances and demonstrations?	6:24
Is a special use permit required?	6:25
H. Other Uses of Museum Objects in Educational, Interpretative and Other Programs and Activities	6:25
Should museum objects be used in educational and interpretive programs?	6:25
Is a special use permit required for using objects in educational or interpretive programs?	6:27
Can museum objects be consumptively used?	6:27
Where can I get information on consumptive use?	6:27
Can I allow destructive analysis of an object?	6:27
Should I allow museum objects to be used for ritual activities?	6:28
Is a special use permit needed when museum objects are used for special events?	6:29
Are consumptive use approval and a special use permit needed for the same activity?	6:29
What forms do I need to complete when an object is going to be out of direct NPS museum control?	6:29
I. Selected Bibliography	6:29
J. List of Figures	6:29

CHAPTER 6: OTHER USES OF MUSEUM COLLECTIONS

A. Overview

1. *What does this chapter cover?*

This chapter addresses the less common uses of museum collections that aren't covered in other chapters of this Handbook (*MH-III*). Topics covered in this chapter are:

- filming and photography in park spaces housing museum collections
- special events in park exhibit spaces
- keeping museum objects in working order
- using museum objects in performances, sound productions, or demonstrations in parks
- using museum objects in educational, interpretative, and other programs and activities in parks

The activities described in this chapter cover uses of museum collections that are out-of-the-ordinary. They will be referred to as "other uses" of museum collections throughout this chapter. Because other uses of NPS museum collections aren't common, the appropriate response to requests for other uses of museum objects may not be obvious to you. Draw on your curatorial experience and refer to the *Museum Handbook* and *Conserve O Gram* series when you evaluate a request. Consult with colleagues, conservators, and your regional/SO curator before allowing such uses of museum collections. This chapter can assist you in making informed, consistent, and fair decisions on when to provide access to park museum collections and the spaces they're housed in for more atypical or "other uses."

While there is some overlap, don't confuse "other uses" of museum collections with uses of park resources that are covered by Director's Order #53: Special Park Uses.

2. *What NPS policies and guidelines do I need to know?*

Familiarize yourself with the Chapter 1, Section C, Management Issues, and the sections related to managing museum collections in the NPS policies and guidelines noted below:

- *Management Policies*, Chapter 8: Use of the Parks
- *Museum Handbook*, Part I (*MH-I*), Chapter 4: Museum Collections Environment, Chapter 6: Handling, Packing and Shipping Museum Objects, Chapter 7: Museum Collections Storage, Chapter 9: Museum Collections Security and Fire Protection, and Chapter 13: Museum Housekeeping
- Director's Order #53: Special Park Uses (DO #53), and *Reference Manual 53: Special Park Uses Guideline (RM-53)*. The document includes the former NPS-21: Filming Guideline.

- *Interpretation and Visitor Services Guideline* (formerly NPS-6))
- *Cultural Resource Management Guideline* (formerly NPS-28, Release 5)
- regional and park-specific guidance and procedures

B. Management Concerns

1. *What management issues should be addressed when dealing with other uses of museum collections?*

Increased access to NPS museum collections contributes to the NPS mission of enhancing public education and enjoyment of resources. Access to, and use of park museum collections must be consistent with NPS policies and procedures. When you consider another use request, carefully weigh all the legal; ethical; cultural; management; scientific; preservation and protection; documentation; and interpretive issues outlined in Chapter 1: Evaluating and Documenting Museum Collection Use. Matters relating to the legal issues of museum collections access and use are described in Chapter 2: Legal Issues. Refer to DO #53 and *RM-53* for detailed information on activities that are covered under the NPS special use permit.

As a manager of the park museum collection, make sure that the:

- collection is protected and preserved now and for future generations. Other use activities shouldn't subject any object, specimen, or archival or manuscript item to unnecessary deterioration.
- public's normal use and enjoyment of the collection whether on exhibition in a visitor center, gallery or historic house, or in collection storage or research space isn't negatively impacted by other uses
- use isn't in conflict with NPS policy and the law
- use doesn't unduly interfere with normal park and museum operations, such as closing an exhibit space or room in a historic house
- use doesn't diminish the values and purposes for which the park was established. Refer to the park's enabling legislation and planning documents for additional information.

Work with a museum collections committee (as recommended in Chapter 1, Section C, Management Issues) to develop park procedures for other uses of museum collections. It's important that the procedures you establish are developed in coordination with relevant staff, in particular, mid- and upper-level park management and staff responsible for issuing the special use permit. A standard park operating procedure will allow you to implement consistent and rational decisions concerning other uses of museum collections.

Access procedures should withstand close review, potential challenges, and litigation. **Note:** Generally, other uses of museum collections don't require a special use permit unless those activities fit the special park uses defined in DO #53 and *RM-53*.

If you allow a non-NPS individual, group, or organization to use museum objects once for non-NPS purposes as described in this chapter, you'll need to permit others the same access, unless there is a legitimate management reason not to do so.

Your decision to allow or deny other uses should be based on the procedures and recommendations outlined in the *Museum Handbook*, DO #53, RM-53, your own skills and experience, and consultation with park management, including the superintendent, specialists, regional/SO curator, and Museum Management Program staff.

Other use activities shouldn't place the collection at risk. When considering such a use:

- know exactly what kinds of activities will take place
- identify the requesting organization or individual
- know the skill level of the responsible individual
- anticipate potential problems when possible

2. *What security risks must be considered?*

Security of the museum collection should be an overriding concern when you make a decision to allow other uses of a museum object. Activities such as special events or demonstrations in confined spaces can generate large and often unwieldy crowds that can increase security risks. **Note:** Other use activities don't exempt users from the guidance outlined in the *MH-I*, Chapter 9: Museum Collections Security and Fire Protection, and Chapter 10: Emergency Planning.

Pay special attention to security and fire protection concerns, such as those noted below:

- Identify the objects that are most vulnerable to security or preservation risk, such as theft, breakage, mishandling, or light exposure. Take special precautions that may include protecting or relocating vulnerable objects during a special event or film shoot.
- Have a museum collection staff member present when the activities take place.
- Don't leave non-museum staff in the collections storage area or building unaccompanied.
- Notify law enforcement and maintenance staff of upcoming out-of-the-ordinary activities.
- Require liability insurance, if appropriate.

3. *What preservation issues must I consider?*

Other use activities shouldn't compromise the long-term well being and stability of the object. The activities described in this chapter can have a direct and often negative impact on museum collections. Access and use for the purposes described in this chapter shouldn't subject museum objects to unacceptable wear, deterioration, or the possibility of breakage, vandalism, or

theft. If the usage poses these risks, then don't allow the activity. Where possible, propose alternatives, such as using a less delicate or significant museum object, a reproduction, or a similar item that isn't part of the museum collection. If possible and practicable, you can also relocate the activity away from the collections to a less vulnerable place, or move the activity to adjacent workrooms, buildings, or grounds near the museum or historic house. You should have exhibit openings and receptions away from the collections and in areas where food and drink are permitted.

Work with the museum collections committee to establish standard operating procedures for dealing with preservation issues related to the other use activities described in this chapter. Refer to *MH-I*, Museum Collections, in particular, Chapter 3: Preservation: Getting Started, Chapter 4: Museum Collections Environment, and Chapter 5: Biological Infestations, when you develop park-specific procedures. See Chapter 1, Section G, for a discussion on how to balance preservation and use.

To facilitate collection preservation, you should:

- inspect the object(s) before you make a recommendation
- make sure the object is cataloged
- document object condition
- photograph the object
- inspect the space before and after the activity takes place
- supervise all use and handling of objects
- allow only suitably qualified people to maintain or demonstrate a museum object
- minimize UV exposure, including sunlight and fluorescent lighting
- avoid heat buildup in exhibit spaces and historic rooms by lowering or keeping lights off when they aren't needed
- don't allow:
 - food and drinks
 - smoking
 - live plants and fresh flowers
 - live animals, except general assistance dogs such as for the sight- or hearing-impaired
- monitor the area for pests
- clean the area before and after the activity

- establish an area away from the collections where visitors can congregate and where food may be permitted

4. *What visitor and interpretation issues should I consider?*

Other uses of museum collections or the spaces that house collections should enhance the visitor's experience. Museum collections are an important park resource. We need to make the visitor's experience of the collections educational and enjoyable. Other use activity shouldn't unduly detract from learning about the collections whether the collections are on exhibit, in storage, being researched, or being used in an interpretive program. The needs of a select group can't impede the needs of park visitors. Exhibits should always be available to visitors during regular hours. Try to accommodate the other use without detracting from the interpretation program and the visitor experience. Of course, you also need to consider the intent and long-term results of the other use, such as a film or video that will greatly expand the audience for the park's museum collections.

To ensure the normal visitation isn't unduly impacted, you should:

- allow access for other uses at times when visitors aren't present
- keep the area open during normal visiting hours, and if necessary, allow controlled visitor access
- provide a brief explanation of the other use activity to visitors

5. *What is considered a special park use ?*

DO #53 defines a special park use as a short-term activity that is proposed for, or takes place in, a park area and that:

- provides a benefit to an individual, group, or organization rather than the public at large
- requires written authorization and some degree of management control from the Service in order to protect park resources and the public interest
- is not prohibited by law or regulation
- is not initiated, sponsored, or conducted by the NPS

The superintendent issues a Special Use Permit (Form 10-114) to an individual or organization to allow a special use of NPS administered resources after evaluating the request in accordance with applicable legislation, regulations and management planning documents, and criteria and procedures outlined in DO #53 and *RM-53*. A special park use may be permitted only if the proposed activity:

- doesn't cause injury or damage to park resources
- isn't contrary to the purposes for which the park was established
- doesn't unreasonably impair the atmosphere of peace and tranquility maintained in wilderness, natural, historic, or commemorative locations within the park

- doesn't unreasonably interfere with the interpretive visitor service or other program activities, or with the administrative activities of the NPS
- doesn't substantially impair the operation of public facilities or services of NPS concessionaires or contractors
- doesn't present a clear and present danger to public health and safety
- doesn't result in significant conflict with other existing uses

Refer to *Management Policies*, Chapter 8: Use of the Parks; DO #53, *RM-53*; and Figure 6.2, Documents Needed for Other Uses of Museum Objects, at the end of this chapter. **Note:** You may recover costs if a special use permit is issued.

6. *When do you need a special use permit?*

The superintendent issues a Special Use Permit (NPS Form 10-114) for all special park uses that don't have a specific, approved permitted instrument. Special permit uses include, but are not limited to filming, grazing, special events, First Amendment activities and military operations. Refer to DO #53 and *RM-53* for detailed information on special use permits. Park uses that have a specific, approved permitting instrument, such as a research and collecting permit, generally don't need a special use permit.

Certain museum-related activities require a special use permit. These activities include special events that occur in exhibit spaces. See Section E for additional information. Certain filming and still photography require a special use permit. For additional information on filming and photography, see Sections C and D.

7. *When don't you need a special use permit?*

NPS employees or contractors don't need a special use permit to perform official NPS business. Non-NPS users of NPS collections don't need a special use permit to:

- do research on:
 - objects, specimens and archival materials housed in collections storage
 - associated collection information in the ANCS+ database wherever the database is located
- make incoming or outgoing loans (Refer to Section H.2 and to *Museum Handbook*, Part II (*MH II*), Chapter 2: Accessioning, and Chapter 5: Outgoing Loans, for detailed information on loans.)
- obtain copies of film, videotapes, sound recordings, and still photographs of NPS museum and archival collections for research, education, scholarly, parody, criticism or news reporting purposes (However, certain legal restrictions such as copyright as outlined in Chapter 2 may apply.)
- film, videotape, make sound recordings, and take still photographs of NPS museum and archival collections unless the activity meets certain requirements as described in Section C and D and Figure 6.2

Researchers don't need a special use permit to access the collections and associated collections data. However, access procedures outlined in Chapter 1 are applicable.

8. *Can I recover costs for other uses of museum collections?*

Refer to Figure 6.2, Documents Needed for Other Uses of Museum Objects, DO #53, and *RM-53*, Chapter 7: Permitting Instruments, for additional information on special use permits.

You can't recover costs for other uses of museum collections described in this chapter if a special use permit hasn't been issued. You can recover costs only if a special use permit has been issued. If a special use permit has been issued, work with your park budget officer to make sure that all special use recovery costs are paid into a special park account. Refer to each section of this chapter as appropriate and to *RM-53*, Chapter 10: Management of Permit Fees, for guidance.

Note: You *can* recover costs associated with making two-dimensional (2-D) reproductions such as photocopying, photographing, microfilming, or digitizing archival and manuscript collections or 2-D collections without a special use permit. Refer to Chapter 4: Two Dimensional Reproductions.

Costs associated with a special use permit may be recovered for:

- staff salaries and benefits, including museum, interpretation, maintenance and law enforcement staff to:
 - do pre-event or activity planning
 - advertise
 - prepare space
 - pull objects from storage or other exhibits
 - relocate vulnerable objects and exhibit cases
 - oversee equipment and furnishings rental arrangements
 - monitor the event
 - clean-up and return the space to its original condition
 - repair and provide conservation treatment for the objects, if needed
- supplies
- utilities
- other physical oversight
- vehicles and other equipment
- travel

C. General NPS Policy on Filming and Photography

1. *What NPS policies and guidelines on filming and photography do I need to know?*

NPS policy allows filming and still photography that is consistent with the protection and enjoyment of park resources. The NPS encourages filming when it is for the specific use of the park or when it assists the NPS in fulfilling its mission. NPS policies and procedures related to filming and still photography are described in *Management Policies*, Chapter 8: Use of the Parks, DO #53, and *RM-53*, Appendix 13: Filming and Photography. A still photography permit application, permit information sheet, suggested permit conditions, suggested park specific guidelines, and a glossary are included in the reference manual. For additional information on photography refer to Chapter 2: Legal Issues, Chapter 4: Two-Dimensional Reproductions, and *MH-II*, Appendix L: Photography.

2. *When is a permit for filming or photography required in the park?*

A permit is required for any filming or still photography that:

- involves the use of a model, set, or prop
- involves commercial filming
- involves commercial advertising
- requires entry into a closed area.

Note: In accordance with PL 106-206, the park can require a permit, fee, or both to do still photography if such photography takes place at locations where members of the public are generally not allowed, or where additional administrative costs are likely.

- requires access to the park before or after normal working hours
- could result in damage to park resources
- could cause significant disruption of normal visitor use and enjoyment

See *RM-53*, Appendix 13, for detailed information. The superintendent determines what costs, if any, may be recovered.

3. *When isn't a permit required for filming and photography in the park?*

Generally, a permit isn't needed for:

- a visitor using a camera and/or recording device for his/her own personal use and within normal visitation areas and hours, including museum exhibits
- a commercial photographer not using a prop, model, or set, and staying within normal visitation areas and hours
- press coverage of breaking news

Press cover of breaking news never requires a permit, but is subject to the imposition of restrictions and conditions necessary to protect park resources

and public health and safety, and to prevent impairment or derogation of park resources or values.

For additional information, refer to Figure 6.2, Documents Needed for Other Uses of Museum Objects.

D. Filming and Photography in Spaces Housing Museum Collections

1. *How do NPS policies apply to filming, movie and video production, and still photography in spaces housing museum collections?*

Generally, park visitors can film, produce movies and videotapes, take still photographs or make sound recordings of a park resource that is on public display or in storage for their own research and enjoyment without needing a permit. These uses will be referred to as “filming and photography.” For additional uses of this material, such as publication, the filmmaker or photographer may be required to obtain appropriate permissions to use the material. Refer to Chapter 2, Legal Issues. You may restrict access to museum storage for preservation and security reasons, and require a researcher registration form be completed to photograph objects that aren't on exhibit. The park may require a permit (see Section D.5). NPS policy provides you with a systematic and rational mechanism to manage film and photography activities in spaces housing NPS museum collections. When you get a request to film or photograph in a space holding museum collections, you should consider the impact on:

- collections in storage and on exhibit
- intellectual property rights, including copyright, privacy and publicity rights
- accessibility to the visitor center, exhibition galleries and historic rooms that house collections
- general park visitors
- researchers
- museum staff needed to accommodate the project

Note: Refer to Chapter 2: Legal Issues, for guidance on how to meet legal requirements related to filming and photography and Chapter 3: Publications, for what is needed in order to use images in a publication.

Don't allow filming or photography if:

- the collections will be subjected to unacceptable light levels and heat buildup, wear, deterioration or the possibility of breakage or theft
- it conflicts unduly with normal visitor use and enjoyment of the collections on exhibit

- unduly interrupts research access to the collections
- places unreasonable burdens on the park staff

Any filming or photography of museum collections is subject to the requirements outlined in Chapter 1, regardless of the equipment used.

2. *What else do I need to know to make a decision about the appropriateness of the use?*

In addition to satisfying the management concerns outlined in Chapter 1: Evaluating and Documenting Museum Collections Use, and the security and preservation needs described above, review all filming and photography projects that involve museum collections to make sure their purposes are valid and they will have no adverse effects:

- Make sure the activity is consistent with the park's purposes and values as described in DO #53 and RM-53.
- Consult with neighboring communities to determine whether or not the filming or photography would have an adverse impact on them before permitting an "other" use of museum collections.
- Consult with affiliated groups to determine whether they would be adversely impacted by filming or photography before permitting an "other" use of museum collections.
- Make sure the law isn't violated (copyright, privacy, publicity) and that all appropriate releases have been obtained. Refer to Chapter 2: Legal Issues, and Chapter 3: Publications, for model releases (see Figure 3.6).

Get satisfactory answers to the following questions:

- Will the activity enhance and support the research and educational mission of the NPS and the park?
- Is the activity related to the park's interpretive themes?
- Will the activity help park visitors better understand and appreciate NPS museum resources?
- Does the resulting film or photograph provide useful information about park resources to the visitor away from the park?
- Will a greater number of researchers and the general public have increased access to NPS museum resources?

If you determine that the activity is potentially problematic, document your findings. Provide your recommendations to the superintendent for his or her approval or denial of the request. **Note:** In accordance with RM-53, Appendix A, 13-2, park managers will not sign location releases supplied by applicants.

3. *When is a permit required for filming and photography in spaces housing collections*

A permit is required for any filming or still photography that takes place in spaces housing collections that:

- involves the use of a model, set, or prop
- involves commercial filming
- involves commercial advertising

4. *When isn't a permit required for filming and photography in spaces housing collections?*

Visitors and researchers don't need a permit for these activities:

- Obtaining copies of films, photographs, videos, or sound recordings when museum and archival collections are used during the course of research activity doesn't require a permit. The photographer, film maker, or recorder must obtain the appropriate intellectual property rights, including copyright, privacy, and publicity permissions. Refer to Chapter 2: Legal Issues, and Chapter 4: Two-Dimensional Reproductions.
- Filming, taking photographs, or making videos or sound recordings as part of a normal park visit in areas usually open for public use during regular visiting hours doesn't require a permit.
- Filming, photographing, videotaping, and sound recording don't require permits *unless* the activity involves the use of a model, set, or prop or is for commercial advertising.
- News crews or sound technicians at news-breaking events and First Amendment activities, such as news conferences or news reporting don't need permits. *Note:* News crews still have to abide by NPS and park policy on filming. Refer to DO #53 and RM-53, Appendix 3, for further information.

Visitors and researchers must complete the Researcher Registration Form and Visitor Log when they film or photograph collections in museum storage and work areas.

5. *When is a permit optional for filming and photography in spaces housing collections?*

In accordance with PL 106-206, the park can require a permit, fee, or both to do still photography if such photography takes place at other locations, such as museum storage and work areas, where members of the public are generally not allowed, or where additional administrative costs are likely. However, the photographer is responsible for obtaining the appropriate permissions, including copyright and privacy permissions. Refer to Chapter 2: Legal Issues, and Chapter 4: Two-Dimensional Reproductions.

6. *What procedures should I implement for filming and photography in areas housing collections?*

Because filming, videotaping, photographing, and sound recording involve additional people and equipment, they have the potential to damage museum collections. You should, whenever possible:

- ***Keep crew size small.*** Large crews in confined areas are a recipe for disaster. Rooms in some historic houses are so small and full of vulnerable and exposed museum objects that filming or photography poses a major threat to the objects. In this instance, the superintendent may prohibit any filming or photography in the space or historic house

itself. You should make every effort to accommodate the crew outside the historic house, on the grounds, or in other appropriate structures free of museum objects.

- **Limit equipment**, such as tripods and strobe lights, to a manageable number of pieces and sizes.
- **Limit lighting strength and duration** to avoid UV exposure and heat build up. Current conservation research indicates that there is little, if any, evidence to prohibit flash photography for preservation reasons. However, some museums don't allow flash photography to avoid possible damage from shattered bulbs or to avoid disturbing other visitors.
- **Determine if you need additional electrical supplies and hookups.**
- **Identify the specific location** where the proposed filming or photography is to take place.
- **Take precautions to protect collections** by:
 - removing or relocating vulnerable objects
 - removing or covering exhibit cases
 - protecting or covering the structure such as room doors or windows
- **Have a staff member present** to monitor filming and photography activity.
- **Allow only trained NPS museum staff to handle the objects.**
- **Control placement of equipment.**
- **Establish a safe "people free" perimeter** around objects and exhibit cases.
- **Protect the vulnerable areas** of the structure, such as door frames, walls, and lighting fixtures.
- **Limit the times** when the crew can film or take photographs.
- **Don't permit violation of copyrights** or other intellectual property rights, such as privacy or publicity rights.

7. *How do I maintain control of filming, still photography, videotaping, and sound recording projects once the project is completed?*

After the filming, still photography, or videotaping project is completed, when possible, make sure the park receives:

- **a full set of negatives** plus a positive print or transparency of each item, preferably on a long-lived film stock, such as a polyester film base
- **copies of all final edited or retouched versions** and any outtakes or unused film footage

- *copies of all quality control tests*, including resolution tests
- *copies of any captions, indices, or directories*

For additional information, refer to Chapter 4: Two-Dimensional Reproductions.

After the sound recording, when possible, make sure that the park receives:

- *a master tape and an edited copy*, preferably on a long-lived film stock, such as a professional quality reel-to-reel tape or short-play professional quality cassettes (less than 60 minutes per cassette) or on CD-ROM
- *copies of all final versions* and any outtakes
- *copies of all quality control tests*
- *copies of any indices or directories*

E. Special Events in Exhibit and Other Spaces Housing Museum Collections

1. *What activities are considered special event activities?*

Exhibition galleries in museums and visitor centers and furnished and unfurnished historic structures are extremely attractive spaces. Exhibit spaces can provide appealing and unique venues for a range of special events. Many non-NPS museums and historic houses routinely host outside groups for a variety of activities. The NPS, unlike private, non-federal organizations, is subject to policies and procedures that govern special events for outside groups on federal property. These policies place certain limitations on special events. The hosting of a special event by an outside group on NPS property is considered a privilege, not a right, and requires a special use permit.

Special events are activities such as:

- ceremonies
- entertainment
- regattas
- large group camps or rendezvous
- pageants
- public spectator attractions
- sporting events

Special events can also include meetings, conferences, film screenings, seminars, symposia, artistic performances, and exhibition opening receptions.

A special event doesn't include activities managed under the Concessions Policy Act. Refer to Director's Order #32: Cooperating Associations (DO #32), and *Cooperating Association Reference Manual (RM-32)* for information on concessions.

The superintendent has to evaluate each special event request in compliance with NPS special use policy, National Environmental Policy Act and Section 106 of the National Historic Preservation Act. The holding of public assemblies and public meetings on NPS property in accordance with the First Amendment of the United States Constitution isn't covered in this chapter. Refer to *RM-53*, Appendix 10: Special Events, for additional information.

2. *Do NPS-sponsored special events require a special use permit?* No. NPS-initiated, -sponsored, or -conducted special events, such as candlelight tours, don't require a special use permit. They are, however, subject to the same requirements that are described in E.7, below.
3. *What NPS policies and guidelines do I need to know?* NPS policy, requirements, and procedures related to special events are described in:
 - *Management Policies*, Chapter 8: Use of the Parks
 - *RM-53: Special Park Uses Guideline*, Appendix 10: Special Events
 - Chapter 1: Evaluating and Documenting Museum Collection Use
4. *Is a special use permit required for a special event?* Yes, a special event requires an approved special use permit, unless another permitting document or agreement is used. The superintendent determines when the special use permit is required. Refer to Figure 6.2, Documents Needed for Other Uses of Museum Objects, and *RM-53*, Appendix 10: Special Events, for additional information.
5. *How do these policies apply to special events in exhibit and other spaces housing museum collections?* Special events pose particular challenges to you, the museum manager, primarily because they have the potential to bring large numbers of people into a relatively confined area. Large crowds have the potential to damage the collection. Crowds make it difficult to maintain adequate security. Increased fire risk and public safety issues also accompany special events.

A special event to be held in spaces housing museum collections should promote increased understanding, appreciation, and enjoyment of the collections that are vital park resources. Only consider a request to hold a special event in an exhibit space, collection storage space, laboratory, or research space once the issues outlined in Chapter 1: Evaluating and Documenting Museum Collections Use, and Chapter 2: Legal Issues, are satisfactorily addressed. Make sure that the special event doesn't present any preservation, protection, or legal risks for the museum collections.

The superintendent may approve a special event request in a space that houses museum collections if it:

- doesn't subject museum collections to preservation and protection risks
- doesn't conflict with law or NPS policy
- doesn't diminish the values and purposes for which the park was established

- contributes to visitor understanding of the park and is related to the park's interpretive themes
- is consistent with the park's enabling legislation, *and*
- there is a meaningful association between the park area and the event
- visitor access to and enjoyment of the park's resources isn't negatively impacted.
- there is no potential to cause:
 - illness
 - personal injury
 - property damage

Work with your museum collection committee to establish standard operating procedures.

Always apply the same procedures to all who request the use of spaces that house collections for a special event.

Consistent implementation of procedures will ensure that the approval or denial of requests is fair and equitable. If you grant one group permission to hold a special event, it will be difficult to deny permission to other groups, and may open the park and NPS to charges of unfair practices.

Many parks, in particular, historic houses, have opted not to permit any special events in exhibit galleries, furnished rooms, or storage areas, irrespective of the requester or the type of event. This prohibition provides the park with a consistent and easily enforceable policy. It also ensures the preservation and protection of the museum collections. When possible, try to accommodate the special event outside the historic house, on the grounds or in other appropriate park structures.

However, if you do permit a special event in an exhibit space, have the event organizer provide proof of insurance and bonding before the special event. Consult with the regional/SO curator and regional solicitor when arranging for insurance. All requesters need to know their responsibilities and liabilities when a special event is approved.

6. *Can I recover costs for hosting a special event in exhibit spaces?*

Yes, you may if a special use permit for the special event has been issued. Special use permit cost-recovery fees are paid into a park account for park use. Refer to Chapter 6, Section B.7 and *RM-53*, Chapter 10: Management of Permit Fees, for information on cost recovery procedures.

7. *What procedures do I need to implement for special events in exhibit spaces?*

If you recommend approval of the special event, include the following conditions in the permit and notify the requester of the requirements:

- ***Require that the special use permit be completed*** at least four weeks in advance of the event.

- **Identify the user's special event coordinator and event host.**
- **Require the user to provide:**
 - a hold-harmless and indemnification clause in the special use permit (See Figure 6.1 and refer to *RM-53*, Chapter 9: Permit Provisions.)
 - a certificate of insurance prior to the event with the park named as additional insured to cover property and collection damage and personal injury during the setup, the event, and the follow-up activities associated with the event
 - a cancellation clause in the permit (Refer to *RM-53*, Appendix 10: Special Events, for additional information.)
- **Arrange for the user-group staff to meet with NPS staff to plan the event.**
- **Establish a maximum number of people allowed in the space.** Don't allow more people into the space than can be easily accommodated. Rooms in some historic houses may be small and filled with many vulnerable or exposed museum objects that may be hard to move. Crowds associated with a special event have the potential to damage the building structure and the collections housed in those spaces.
- **Specify which areas are available** for the event, including what preparatory spaces may be used, and provide adequate washrooms.
- **Establish duration of the event:**
 - Set hours for the event. If the event is going to be housed in a public space, make sure that regular visitor access isn't negatively impacted.
 - Include set up, delivery, and pick-up arrangements, take down, and clean-up time in your calculations.
 - Factor in time and contingency planning in case of an emergency.
- **Identify the type of event**, whether it will be a sit-down or standing event, and determine table and seating requirements, if necessary.
- **Don't allow:**
 - food or drinks
 - smoking
 - live plants or fresh flowers
 - live animals, except general assistance dogs, such as for the sight or hearing impaired

- **Limit equipment**, such as loud speakers.
- **Allow only trained NPS museum staff to handle** the objects and furnishings:
 - Always have a NPS staff member present for the duration of the event.
 - Identify the NPS staff member who will give a guided tour of the exhibit or house.
- **Take precautions to protect collections by:**
 - removing or relocating vulnerable objects
 - removing or covering exhibit cases
 - protecting or covering doors or windows in spaces housing collections
 - making sure no decorations are applied to the structure, furnishings, or objects without NPS permission
- **Monitor and control the relative humidity and temperature** during crowded events, where possible.
- **Implement fire regulations.** Prohibit smoking, candles, and open flame lamps.
- **Require advance payment to recoup costs**, if appropriate.

8. *What special events aren't permitted in spaces that house museum collections?*

In addition to the limitations outlined in *RM-53*, don't permit any special event in spaces that house museum collections that:

- causes injury, damages, or negatively impacts the preservation and protection of the museum collection
- unreasonably interferes with the park's museum program services or activities
- results in a significant conflict with other park museum program activities
- is conducted primarily for the material or financial benefit of participants
- involves commercialization, advertising, or publicity by participants
- charges a separate public admission fee, unless the event is directly related to the purposes for which the park was established

Refer to Section B.5, When don't you need a special use permit? Be aware of the potential negative publicity that may arise if an alcohol-, tobacco-, or

weapons-related organization uses NPS property for a special event. Consult with the regional/SO curator and solicitor if you get such a request.

9. *What issues must I consider about painting and sketching?*

Generally, painting and sketching in exhibit spaces tends to be a solitary activity. However, groups or classes may be involved. Refer to the preservation and security sections of this chapter when evaluating a request to paint or sketch in exhibit spaces and follow these guidelines:

- **Limit the number and placement of equipment**, such as easels, carts, stands, tripods, and lights, to a manageable number of pieces and sizes.
- **Limit lighting intensity and duration** to avoid UV exposure and heat build up.
- **Make sure that supplies, such as paints and water, are properly housed** to avoid spillage or leakage.
- **Establish a safe distance** from the museum objects for the artist to set up equipment.
- **Set up the object in a separate space** to minimize visitor impact, if possible.
- **Require the artist to obtain all intellectual property rights if the work is not in the public domain.** The artist must obtain copyright, privacy, and publicity permissions prior to use, unless the painting or sketch will be used for teaching, private study, scholarship or research, satire, parody, commentary and criticism, and news reporting. He or she needs to sign a copyright and privacy statement to this effect. Refer to Chapter 2: Legal Issues, for additional information.

F. Museum Objects in Working Order

1. *Should I keep museum objects in working order?*

There's no simple answer to this question. You'll need to weigh the advantages and disadvantages before making an informed decision. Consult with a conservator and your regional/SO curator. However, it's standard museum practice that once an item is accessioned into the collection, it enters the realm of "museum object" rather than "functional item."

You should take every precaution to avoid unnecessary wear and tear on the object. This means you should carefully consider a request to use the object for its original function, such as a carriage or car to be used in a local parade. This kind of activity could result in considerable damage and deterioration. Less obvious examples of use include playing musical instruments and running machinery such as a printing press or phonograph.

While the quotation noted below was written for musical instruments, it could be applied to most museum objects.

“Although it was once taken for granted that old musical instruments would whenever possible be restored to playing condition, today many museums and private collectors prefer to use copies. This protects the original from loss of historical value and avoids the painstaking,

expensive, and continuing documentation, restoration, and maintenance work required to put and keep an historical instrument in playing condition...Original and unaltered instruments often bring a premium over restored ones... An original, unaltered, well-documented instrument will always be of much more interest to the scholar, or to a future craftsman looking for models on which to base his or her work...In particular, historically significant instruments in unrestored, original condition should seldom, if ever, be put into playing condition..."

Scott Odell, *Caring for Your Collections*, 1992.

Getting an object into working condition can require some drastic changes or use of materials that may compromise the object's intrinsic value. For example, making an airplane airworthy would require making some unacceptable changes to the aircraft. In this instance, it would be preferable to restore the aircraft to the correct historic appearance for a static display. You could then interpret the activity by using another object that isn't in the museum collection, or show a video or film of an airplane in flight or a machine in motion. Getting the right and historically appropriate parts can also be difficult and often expensive.

While using a museum object may have educational and aesthetic value, it can subject the object to deterioration when it is run or played during a rehearsal, performance, or demonstration. Refer to Section G, Museum Objects Used in Performance, Sound Production, or Demonstration.

2. *Do I need a special use permit to keep museum objects in working order?* No, on two counts. As a NPS employee you don't need a special use permit to conduct park business. Also, keeping a museum object in working order isn't considered a "special" activity, whether it is done by a NPS employee or under a NPS contract or agreement by a non-NPS individual.
3. *Do I need approval for consumptive use to keep an object in working order?* Yes, unless no wear would occur. Refer to consumptive use procedures in *Cultural Resource Management Guideline*, Chapter 9, Section D.4, Consumptive Use of Museum Objects, and Section F.4.
4. *Under what circumstances should I keep museum objects in working order?* In certain instances, it may be necessary to keep an object in working condition, if the object:
 - is critical to a park exhibit or interpretive program and no other similar objects are available
 - may deteriorate if it isn't kept in working condition, such as a piano

An object that is exhibited in working motion allows the visitor to see how the item works. It also conveys motion and sound that has an important interpretive function. Demonstrating how the object works may add to our understanding of its purpose and significance. **Note:** A video or sound recording of the object in use may be as effective as a demonstration for educational or interpretive uses.
5. *What kinds of objects may be kept in working order?* Certain types of objects in museums have been kept in working order. Objects include:
 - artwork, such as mobiles

- machinery and equipment, including clocks, drills, engines, grinders, lathes, watches, and weaponry
- musical instruments, including brass instruments, such as horns and clarinets; keyboard instruments, such as pianos and harpsichords; and wind instruments, such as flutes and oboes
- transportation, such as aircraft, cars, buses, and tractors

6. *What do I need to consider before allowing objects to be put into working order?*

Remember that objects have artifactual, associational, informational, evidential, and monetary value. They're in the museum collection for their significance, rather than the need to perform a function. Don't jeopardize these values by subjecting the object to deterioration that may result from use or maintenance needed to keep the object in working order. The decision to operate or run an object should be considered on a case-by-case basis.

Operating most mechanical objects will result in considerable wear and tear.

Before you make a decision to allow an object to be put into working condition, consider:

- ***Rarity of the object:*** Don't put a rare or one-of-a-kind item into operation or working order, if:
 - the object was manufactured as a prototype or "one-of-a-kind"
 - few similar objects remain in existence
 - it's the only such object in the park's collection
- ***Significance of the object:*** If the object is significant for one of the following attributes:
 - associated with an eminent person or group
 - associated with a historic event
 - artifactual or intrinsic value as a material culture object
 - information source of baseline data
 - evidence of activity, era, or legal proof
 - administrative value necessary for park activities
- ***Skilled operators or players:*** Make sure only highly skilled operators or players actually use the object or keep it running. Otherwise, it can be severely compromised or damaged.

- **Cost of operation and maintenance:** The cost of operation can be prohibitive. Consider whether the park has the resources, skills, and equipment to keep this item operating and maintained.
- **Life span of the object:** Consider whether the activity shortens or lengthens the life expectancy of the object.
- **Safety:** Protect the health and safety of NPS staff and operators and visitors by taking appropriate precautions.
- **Replacement of parts:** You need to consider whether incorporating non-original parts into the item is appropriate. Making alterations and adding new parts reduces the authenticity of the object and may compromise its significance. Historically correct or reproduction parts may change the nature and value of the object. Certain parts may be prohibitively expensive to find or reproduce. Retain the removed original parts in the museum collection. Mark the new or reproduction parts in accordance with *MH-II*, Chapter 3, Section D, Techniques of Marking and Numbering Museum Objects.
- **Frequency of operation:** Determine how often and when the object will be operated.
- **Preservation and conservation:** Identify what conservation treatment and ongoing preservation care is necessary to keep the object in working order. Make sure that all parts of the object are in reasonable running condition and aren't deteriorating. Establish a baseline condition to which the working object is to be reasonably maintained. Keep in mind the object's significance when you do this.

7. *How do I document an object in operation?*

Document the object in operation, if at all possible, before it comes into the NPS museum collection and if you operate it in the park. To document the activity:

- Develop and maintain an operation and maintenance manual for items to be kept in working order in the park museum collection.
- Keep an operation and inspection log, including user's name, date, length of operation, and problems noted.
- Record all work carried out on the object.
- Record the original context of the item.
- Take photographs, make drawings, and take measurements of the object in situ, when possible.
- Number and track every part of the object before moving it to the park museum collection.
- Research the social and economic background of the object.
- Record it in operation.

- Make a video of it in motion.
- Obtain:
 - operation and maintenance manuals and records
 - measured plans
 - patterns
 - parts catalogs
 - patent drawings
- Collect or record all items associated with the object's construction, operation and use.
- File documentation in the accession or catalog folder

8. *What conservation and maintenance issues do I need to consider?*

As a rule, it isn't essential for museum objects to be kept in running order to ensure their physical preservation. However, if you choose to maintain an object in working order, you need to establish which objects, such as machinery, can benefit from intermittent operation to prevent clogging and sticking of parts. In some cases, machinery or equipment needs to be oiled, given new parts, or turned by hand to make sure the part/item is maintained in good condition. You may need to "loosen up" the object. Generally, it is good practice to disengage machinery or vehicles when not in use. Make sure that all parts of the working object are in reasonably good running condition and aren't deteriorating. If you choose to keep it running:

- Reduce the causes of deterioration where possible.
- Keep treatment to a minimum. Consider the object's significance when you establish the condition to which the working object is to be maintained.
- Provide a stable environment and minimize light, excessive humidity, and temperature fluctuations
- Monitor for pests.
- Regularly monitor condition.
- Document all conservation treatments.
- Take special precautions to ensure physical security of the working object.
- Avoid moving the object unnecessarily.
- Develop a maintenance manual.

G. Museum Objects Used in Performances, Sound Productions, or Demonstrations

1. *What kinds of uses are covered in this section?*

This section describes using museum objects for their intended original or adapted functions in a performance, demonstration, or in a sound production, including:

- live performances:
 - at the park site, in an exhibit space or visitor center
 - on a park stage or other stage
 - in a studio
 - in an outdoor setting

The park may have an interpretive program that presents performances that are broadcast live, or a program that uses museum objects in:

- recorded performances:
 - at the park site
 - on a park stage or other stage
 - in a studio
 - in an outdoor setting
- demonstrations :
 - in an exhibit at the park or off-site
 - in an interpretive tour
 - on a stage
 - in an outdoor setting

2. *What kinds of objects are used in performances, sound productions, or demonstrations?*

The museum objects listed below tend to be used in performances, demonstrations, or in sound productions:

- musical instruments, including drums, flutes, pianos, and violins
- items, such as films, lanternslides, stereographs, oral history tapes, phonograph records, juke boxes, sheet music, videotapes , wax cylinders, and wire recordings
- technical equipment, such as phonographs and recording devices

- machinery and equipment, such as business machines and tools
- vehicles, such as cars, carriages, buses, wagons, and tractors

3. *Should I allow objects to be used in performances, sound productions, or demonstrations?*

Generally not. There's been a shift away from playing or operating museum objects, in particular, musical instruments and equipment and machinery. Current thinking in the museum and conservation community is that you don't need to keep objects in working condition for preservation or conservation reasons. Therefore, with few exceptions, the only reason you'd allow an object to be played or operated would be for interpretive purposes. However, many museum curators and conservators now believe you should limit use or not allow museum objects to be used in performances or demonstrations. Many of the issues raised by using museum objects in performances and demonstrations are also addressed in Section F, Museum Objects in Working Condition.

Where possible, use an authentic reproduction or appropriate period piece that isn't part of the museum collection. This eliminates unnecessary wear and tear on museum objects.

Remember that the museum objects associated with an eminent person or event are irreplaceable. Once they're used up or destroyed, they're gone forever. This is especially true if you're keeping an object in working condition throughout the whole year just to use it once or twice a year, such as a phonograph, car, or lathe. The actual running may prove to be unnecessarily stressful to the object. Consider each request on a case-by-case basis.

Another issue is that objects in working order frequently need replacement of parts. This can compromise the integrity of objects. It is of particular concern when you're dealing with one-of-a-kind objects or those that belong to an eminent person. In this case, you'd want to ensure that every component of the object is original and has not been subjected to any unnecessary wear and tear.

Don't permit the use of a museum object in a performance, sound production, or demonstration unless there is a compelling reason, such as a special interpretive or educational or research need. Record usage, such as taping a sound record or filming the activity, to meet future requests for use. Keep objects in good stationary exhibit condition.

4. *What issues do I consider for objects in performances and demonstrations?*

Many of the issues associated with using objects in performance and demonstrations are addressed in Section F, Museum Objects in Working Order. However, because performances and demonstrations can damage museum objects, wherever possible:

- Use a museum object to perform or demonstrate in consultation with a conservator and the performer or demonstrator.
- Allow only highly skilled performers or expert craftsmen, artisans, or engineers to demonstrate or use museum collections in performances. Unskilled artisans or performers can do immense damage to museum objects.

- Have a staff member present during the performance or demonstration.
- Record the use so that the audio or videotape can be used to meet future requests for performances or demonstrations.

5. *Is a special use permit required?*

You usually don't need a special use permit to use an object in performance or for a demonstration unless it occurs in the context of a special event. For additional information, refer to Section B.6, Figure 6.2, Documents Need for Other Uses of Museum Objects, and DO #53, for additional information.

6. *Do I need approval for consumptive use?*

Yes, unless no wear would occur. Refer to consumptive use procedures in *Cultural Resource Management Guideline*, Chapter 9, Section D.4, Consumptive Use of Museum Objects, and Section F.4.

H. Other Uses of Museum Objects in Educational, Interpretative, and Other Programs and Activities

This section addresses other uses of museum objects that tend to place the object at higher risk of damage than common uses, such as study or display. It includes uses of museum collections in educational and interpretive programs, where the object functions as originally intended and/or is used consumptively, in destructive analysis for research, in rituals, and in special events.

1. *Should museum objects be used in educational and interpretive programs?*

Yes, under certain circumstances. Museum collections are valuable park research, interpretive, and educational resources. The NPS maintains collections because they document the park story and are primary resources in their own right. Museum objects can be used to enrich NPS programs, fostering increased understanding of our cultural and natural heritage and expanding the visitor experience of the park. Work with park interpretive staff to make sure that objects, particularly those on exhibit, are incorporated into park educational and interpretive programs.

However, using objects "outside" of the exhibit for educational and interpretive programs can present a set of management challenges. Some of these activities include using an object as a "show and tell" for a group of visitors, interns, or students. Before you allow an object to be used in an educational or interpretive program, you should get satisfactory answers to the following questions:

- Can a reproduction or a similar item that isn't in the museum collection serve the same purpose?
- Is the object or specimen common and is it well represented in the collection?
- Is the object or specimen rare, and does it have special significance?

- For archeology and natural history, is the artifact provenienced, and does the specimen have collecting locale information, and for archival collections, does the item have documented provenance?
- Is the object in stable condition?
- Is the object especially vulnerable to light, heat, or handling damage?
- Will the use compromise the object's structural integrity or appearance? Will the object be subjected to unacceptable wear, deterioration, or destruction?
- Will the person handling the object be trained in appropriate handling techniques?
- Is there a possibility the object could get broken or be stolen?
- Can the object withstand the additional handling and wear and tear involved?
- Will the use contribute to the park's mission?
- Will the use benefit the park visitors' experience?
- Does the use contribute to our knowledge and understanding of the object?
- Have you consulted with the affiliated group(s) for culturally sensitive materials prior to use?
- Is the object subject to the Native American Graves Protection and Repatriation Act (NAGPRA)? If so, don't use it without concurrence of the affiliated tribe. Don't use any human remains subject to NAGPRA.
- Are hazardous chemicals associated with the object? For example, have pesticides been applied to the object to make it harmful to handle?

Museum objects aren't props and aren't expendable. If there is any question about the object's stability and condition, don't use it. Always err on the side of preservation. ***Preservation is paramount.*** Remember that you've accessioned objects into the museum collections because they have long-term value as a park resource. If you have a rare or highly significant object, use a substitute, reproduction, or non-museum piece for interpretive or educational purposes if there is a risk of damage.

<p><i>Make sure the object is subjected to minimal handling.</i></p>

If you decide to use the object, make sure that it is viewed or handled under carefully controlled conditions. Don't let everyone have a turn at handling, rather, just allow the object to be shown by the interpreter or speaker. This should minimize deterioration and extend the object's life.

2. *Is a special use permit required for using objects in educational or interpretive programs?* No. A special use permit isn't required to use objects in educational or interpretive programs, either in the park or away from the park. Follow outgoing loan procedures when an object is removed from storage for an educational or interpretive program. Refer to Figure 6.2, Documents Needed for Other Uses of Museum Objects. See *MH-II*, Chapter 5: Outgoing Loans.

3. *Can museum objects be consumptively used?* Under certain circumstances, they can be. In order to use objects consumptively, the use must add to our knowledge of the object. You as a museum manager need to weigh the benefits of such use against the long-term preservation of the museum object. For additional information, refer to *Cultural Resource Management Guideline*, Chapter 9, Section D.4, Consumptive Use of Museum Objects. All decisions to permit consumptive use must be consistent with resource preservation and the interpretive values of the park. **Note:** The regional director (and in special cases, the director) approves consumptive use.

Good museum practice and NPS guidelines emphasize that preservation has to be a primary concern when you consider a request for consumptive use. You need to make sure that the object is going to be available for future generations. This means that you shouldn't expose the object in any way to unacceptable wear, deterioration, destruction, or the possibility of breakage, loss, or theft. You have to fully understand what the consumptive use is and what will be its effect on the object.

For approval of consumptive use, follow the procedures outlined in *Cultural Resource Management Guideline*, Chapter 9, Section D.4. **Note:** If there is any chance of unacceptable wear and tear or loss, always err on the side of preservation. Whenever possible, you should use reproductions or similar items that aren't in the museum collection.

Don't permit consumptive use of items subject to Native American Graves and Repatriation Act (NAGPRA) without the prior approval of the affiliated cultural group and the regional director (or director).

4. *Where can I get information on consumptive use?* Consumptive use is described in:

- Chapter 1, Section C.5, What do I need to know about consumptive use?
- *Cultural Resource Management Guideline*, Chapter 9, Section D.4, Consumptive Use of Museum Objects
- *MH-II*, Chapter 4, Section V, Consumptive Use of Museum Objects

5. *Can I allow destructive analysis of an object?* Under rare circumstances, you can allow destructive analysis for approved research purposes when impact is minor or the object is common. Evaluate all requests to do destructive analysis fairly and equitably. Work with the collections committee as described in Chapter 1, Section C.1, to evaluate requests and assist in developing standard operating procedures for doing destructive analysis. Your decision to allow destructive analysis must be rational, consistent, and in the best long-term interest of the collection. You should weigh the amount of information you hope to gain against what you will lose as a result of the destructive analysis. For example, sampling an archeological object can yield significant information about its age that can enrich the research baseline of the collection as well as provide useful information for the park's interpretive program.

Refer to Chapter 1, Section F, Scientific Issues, for information on scientific analysis of museum specimens. Destructive analysis depends on the object and needs to be done on a case-by-case basis. You have to determine what will be learned from the analysis, and whether the results of the analysis outweigh the long-term preservation of the object.

The superintendent approves a request to do destructive analysis. A request to do destructive analysis on a rare or significant object must be reviewed by the regional/SO curator and approved by the regional director. Refer to Chapter 1, Section C.5, What do I need to know about consumptive use? and follow the procedures outlined in the *Cultural Resource Management Guideline*, Chapter 9, Section D.4.

6. *Should I allow museum objects to be used for ritual activities?*

Consider requests to use museum objects ritually on a case-by-case basis. Because using a museum object ritually may involve high risk of damage, such use should be a rare occurrence. Refer to *Cultural Resource Management Guideline*, Appendix R: Native American Graves and Repatriation Act (NAGPRA) Compliance, and regional guidance for information on how to handle requests for items subject to NAGPRA.

When possible, you should encourage the requester to use a similar item that isn't in the museum collection, such as recommending the requester obtain a non-museum collection basket to use in a wedding ceremony instead of using a museum object. Under rare circumstances, you can allow a museum object to be used ritually. Work with your museum collections committee to establish a standard operating procedure to respond to requests to use museum objects for ritual activities. For example, you may permit a mask to be used and "fed" with pollen during the performance of a ritual.

If culturally appropriate use of an object can't be accommodated in museum spaces, then you can prepare an outgoing loan agreement. Remember that loan procedures don't allow loans to individuals, only to organizational entities, such as tribes, museums, and historical societies. Consult with the borrower regarding the "Purpose of Loan." If you think that the object may be repeatedly requested for ritual use, consider storing it separately from other objects. You'll need to take additional precautions to make sure that the object is pest free before it's returned to storage.

Only permit ritual use of items subject to NAGPRA with the consent of the traditionally affiliated groups. Consult with the recognized responsible official of the affiliated group(s).

As with other uses described in this chapter, you should first make sure that the object is stable and that the ritual use won't compromise its long-term preservation. Then you should evaluate the significance of the specific object for the affiliated community or group that made or used the object. You should consult with all affiliated group(s) before authorizing the use. Consider each request and apply your rationale equitably.

Ritual use includes on-site or off-site use. Document the activities and circumstances related to the use. Where possible, include the documentation in the accession or catalog folder. This information enriches our knowledge of the culture and contributes to the specific object's history.

- | | |
|--|--|
| 7. <i>Is a special use permit needed when museum objects are used for special events?</i> | Yes. If museum objects are used on-site for special events such as a ceremony or entertainment, a special use permit is needed. See <i>RM-53</i> for additional information on obtaining a special use permit. Museum objects that are used on-site for special events are subject to the requirements outlined in Chapter 1 and Section H.1 of this chapter. |
| 8. <i>Are consumptive use approval and a special use permit needed for the same activity?</i> | No. You don't need a consumptive use approval and special use permit for the same activity. Consumptive use approval is needed for NPS uses. Non-NPS uses should be non-consumptive. Special use permits are needed for non-NPS uses. |
| 9. <i>What forms do I need to complete when an object is going to be out of direct NPS museum control?</i> | Use an outgoing loan to track NPS and non-NPS uses of objects that are outside spaces that house collections. You'll need to generate an outgoing loan agreement (Form 10-127 Rev.) when a museum object is borrowed for either on-site or off-site use. You should also complete an Object Condition Report (Form 10-637). Procedures for outgoing loans and loan conditions are fully described in <i>MH-II</i> , Chapter 5: Outgoing Loans. |

I. Selected Bibliography

- Barclay, Robert L., ed. *The Care of Historic Musical Instruments*. Co-published by International Council of Museums and the Canadian Conservation Institute, The Museums and Galleries Commission (UK) and International Committee of Musical Instrument Museums and Collections (CIMCIM), 1997.
- Bond, Hallie. "Visitor Safety and Operating Historic Machine Shop Tools." *The Museologist* 48, no. 170, (Spring 1985): 28-30.
- Hay, Duncan. *Technology Collections, Part 1: Operation and Preservation of Machinery and Laboratory Equipment*. Edison National Historic Site Collection Management Plan, 1993.
- Museums & Galleries Commission. *Standards in the Care of Larger and Working Objects: Social and Industrial History Collections*, 1994.
- National Park Service. *The Secretary of the Interior's Standards for Historic Vessel Preservation Projects with Guidelines for Applying the Standards*. U.S. Department of the Interior, National Park Service, National Maritime Initiative, May 1990.
- Schultz, Arthur W., General Editor. *Caring for Your Collections*. National Institute for the Conservation of Cultural Property. Harry N. Abrams, 1992.
- Sibley, Kathryn. "Enchanted Evenings-Without the Morning-After Headaches." *Museum News* (October 1987).

J. List of Figures

- Figure 6.1. Hold Harmless or Liability Clause to be Included in a Special Use Permit6:30
- Figure 6.2. Documents Needed for Other Uses of Museum Objects.....6:31
- Figure 6.3. Sample Conditions to Attach to a Special Use Permit in Spaces Housing Museum Collections6:32

Hold Harmless or Liability Clause

The user shall be fully responsible for the acts and omissions of its representatives, employees, contractors, and subcontractors connected with the performance of this Permit. The user, in furtherance of and as an expense of this Permit, shall:

- (a) Pay the United States the full value of all damages to the property of the United States caused by such a person or organization, its representatives, or employees; and
- (b) Indemnify, save and hold harmless, and defend the United States against all fines, claims, damages, losses, judgements, and expenses arising out of, or from, any omission or activity of such person, organization, its representative, or employees.
- (c) Provide the NPS with certification of public and employee liability insurance coverage.

Figure 6.1. Hold Harmless or Liability Clause to be included in a Special Use Permit

Non-NPS Use of NPS Museum and Archival Collections	What Documents Do I Need to Generate?
Special events in park spaces housing collections, such as ceremonies, entertainment, large group camps or rendezvous, regattas, pageants, public spectator attractions, and sporting events	A Special Use Permit (Form 10-114) and an Outgoing Loan Agreement (Form 10-127 Rev) are required. An Object Condition Report (Form 10-637) is strongly recommended.
Commercial filming and still photography in park exhibit and other park areas housing collections that involve commercial motion pictures, television productions, or still photography with professional casts, settings, or crews	Photography/Filming Permit and, if in collection storage or work area, Researcher Registration Form are required. A Visitor Log entry is made if the activity takes place in the museum collections storage area.
Filming, photography, videotaping, sound recording, and still photography in exhibit areas if done as part of a regular park visit in areas open for public use during normal visiting hours	None.
Filming, photography, videotaping, sound recording and still photography in park collection storage or work areas that don't involve commercial filming and still photography with professional casts, settings or crews	Researcher Registration Form is required. A Visitor Log entry is made if the activity takes place in the museum collections storage area.
Accessing non-public Automated National Catalog System (ANCS+) data wherever the database is located	Complete the Visitor Log and/or Researcher Registration Form. Curator provides USER ID for system access.
Painting and sketching in park areas housing collections	Complete the Researcher Registration Form. A Visitor Log entry is made if the activity takes place in the museum collections storage area.
Researching collections in park collection storage or work areas	Complete the Researcher Registration Form. A Visitor Log entry is made if the activity takes place in the museum collections storage area.
News crews or sound technician at news breaking events	No special use permit needed. Refer to DO #53: Special Park Uses.
First Amendment activities	No special use permit needed. Refer to DO #53: Special Park Uses.
Using objects on-site in performance, sound production, and demonstrations other than special events	Outgoing Loan Agreement is required. An object condition report is strongly recommended.
Using objects off-site in performance, sound production, and demonstrations	Outgoing loan agreement is required. An object condition report is strongly recommended.
3-D Reproductions (discussed in Chapter 5)	A Special Use Permit is needed if the project was non-NPS initiated. You may recover costs if a special use permit is issued. See Chapter 5 for when a reproduction agreement, contract, or cooperating association agreement is needed.
Using objects in educational or interpretive programs on-site	Outgoing loan agreement is required. (This is a common, rather than a special use of museum objects.)

Figure 6.2. Documents Needed for Other Uses of Museum Objects

Sample Conditions for Approving a Special Use Permit in Spaces Housing Collections

The _____ (Park Name), National Park Service, welcomes your interest and special use permit request. Please complete the following:

Describe activity:

Activity start date: _____ end date: _____

Park spaces you wish to use:

Special event coordinator (name):

Describe special needs to be met by the park:

Number of people involved in the activity:

If your Special Use Permit is approved, you must comply with the conditions noted below.

- No food or drinks are allowed.
- Filming and photography lighting equipment and procedures must comply with guidance outlined in the *Museum Handbook*, Part I, Chapter 4, Section E, Light.
- Equipment, such as tripods and strobe lights, are limited to _____ (number of pieces and size).
- Only trained NPS museum staff are permitted to handle the objects and furnishings.
- Vulnerable objects and areas of the structure, such as door frames, walls and lighting fixtures must be protected.
- No live plants and fresh flowers are permitted.
- No candles and open flame lamps are permitted.
- Smoking is not permitted.
- User will address all intellectual property rights, copyrights and other rights in accordance with *Museum Handbook*, Part III, Chapter 2: Legal Issues, if appropriate.
- User must provide liability insurance or arrange for liability insurance that:
 - includes a hold-harmless and indemnification clause
 - provides NPS with a certificate of insurance with the park named as additional insured to cover property and collection damage and personal injury prior to and during the event
- User is liable for costs, including staff salaries to:
 - set up the space, protect or move vulnerable objects and exhibit cases
 - oversee equipment rental
 - monitor the event
 - return the space to its original condition
 - clean up
 - repair and restore the space and/or collections, if needed

Advance payment to recoup costs may be required.

Figure 6.3. Sample Conditions to attach to a Special Use Permit in Spaces Housing Museum Collections

Chapter 7: Using Museum Collections in Exhibits

	<u>Page</u>
A. Overview	7:1
What information will I find in this chapter?	7:1
What is a museum exhibit?	7:1
Why does the NPS produce exhibits?	7:2
Why should I use museum collections in exhibits?	7:2
B. Finding Background Information	7:2
How do I identify the need to develop an exhibit?.....	7:2
What NPS documents have information I can use to develop an exhibit?	7:3
Where do I go for help when planning an exhibit?	7:4
What steps do I need to take to develop an exhibit contract?	7:5
What's the park's role in determining who'll work on an exhibit?	7:6
C. Getting Started	7:7
When do park exhibits happen?	7:7
What kinds of museum exhibits are there?.....	7:7
What types of exhibits will fit my park's exhibit needs?.....	7:8
What materials, media, and resources do park exhibits contain?.....	7:8
Who should be on the park exhibit team?.....	7:9
How can a team work most effectively to prepare an exhibit?	7:11
D. Defining the Purpose and Audience	7:12
What steps do I take to develop exhibit themes and goals?.....	7:12
How do I conduct research for an exhibit?.....	7:13
How do I define the target audience?	7:14
What should I know about park museum visitors?	7:14
What special population issues do I need to consider?.....	7:16
Should the local community be involved with the exhibit?	7:17
E. Planning and Designing Exhibits	7:17
Are there policy issues to be considered?.....	7:17
What are the overall planning and design strategies?.....	7:18
What are the overall preservation and protection strategies?	7:18
What are the collection management priorities?	7:19
What factors should I consider when selecting objects for exhibit?	7:19
What is the project coordinator's role?.....	7:20
What steps does the team take to plan and design exhibits?	7:20
How do I write effective museum exhibit label copy?.....	7:21
F. Producing and Installing Exhibits	7:23
What steps are involved in exhibit production and installation?	7:23
What are the "closeout" steps before opening an exhibit?	7:24
G. Exhibit Planning, Design, Production, and Installation Documents	7:25
What planning and design documents do I need?	7:25
What does a schematic plan and design include?	7:26
What does a concept plan and design include?	7:26
What does the final planning notebook and design drawing include?.....	7:27
Who gets copies of exhibit planning, design, production, and installation documents?	7:27

H. Exhibit Conservation	7:27
What is the role of the exhibit conservation specialist?.....	7:28
Should a conservator be involved in selecting objects for exhibit?	7:28
What exhibit conservation guidelines do I follow?	7:28
What facility issues do I need to consider?.....	7:29
How do I plan for conservation treatment of exhibit items?.....	7:29
How long should objects be on exhibit?.....	7:30
I. Preserving and Protecting Objects in the Exhibit Process	7:30
How do I address temperature and humidity control in an existing exhibit space?	7:30
How do I address particulate contamination in an exhibit space?.....	7:32
How do I deal with chemical pollutants in an exhibit space?.....	7:32
How do I balance exhibit lighting needs with preservation requirements?	7:32
How do I avoid a biological infestation in an exhibit?.....	7:34
What should I do about physical security in an exhibit?.....	7:35
What should I do about emergency preparedness and fire protection for an exhibit?.....	7:35
How should I protect objects during production and installation?	7:35
J. Exhibit Case Design	7:36
What do I need to know about exhibit case design and construction?.....	7:36
What do I need to know about sealed and ventilated exhibit cases?.....	7:36
What do I need to know about exhibit case materials?	7:37
What do I need to know about exhibit mount design and fabrication?.....	7:38
K. Traveling and Non-NPS Initiated Exhibits	7:39
What do I need to know about traveling exhibits at the park?	7:39
What should I do if the park is solicited to provide an exhibit venue?	7:40
What do I need to know about photography, reproduction, and publicity for the exhibit?.....	7:41
L. Exhibit Funding and Outreach	7:41
How do I get support for my exhibit concept?	7:41
What are some funding sources?	7:42
How do I estimate exhibit costs?	7:42
Can I develop a traveling exhibit?	7:43
Should I develop an exhibit Web feature?.....	7:43
Should I produce an exhibit catalog?.....	7:43
Should I train staff and volunteers to interpret a new or upgraded exhibit?	7:43
Should I develop school programs and kits for the exhibits?.....	7:44
How do I promote the exhibit within the community, across the state, or across the nation?	7:44
M. Documenting Collections on Exhibit	7:45
How do I document collections going on exhibit?	7:46
What do I need to know about acquiring rights to images?	7:48
Should I insure borrowed objects?.....	7:49
How should I document the artwork and maps that are prepared for the exhibit?.....	7:49
How do I handle reproduction of an object or image?	7:49
N. Evaluating Exhibits	7:49
Why evaluate exhibits?.....	7:49
What kinds of exhibit evaluations are there?	7:49
When do I conduct the final exhibit review?	7:51
How do I evaluate the exhibit's effectiveness for visitors?	7:51

How do I correct minor factual errors.....	7:51
How do I track visitation to the exhibit?	7:51
O. Maintaining Exhibits	7:52
Who maintains exhibits?	7:52
What's included in an exhibit maintenance manual?	7:52
What is a park maintenance kit?	7:54
What ongoing maintenance activities do I need to undertake?	7:54
How do I monitor object condition?.....	7:55
When do I monitor the environment?	7:55
How do I handle requests to photograph the exhibit or the objects?.....	7:56
How do I establish information files to answer inquiries from staff and visitors?.....	7:56
What do I do if I need to take the object off exhibit temporarily?	7:56
P. Rehabilitating Exhibits	7:56
When should I rotate objects?	7:56
What should I do if an object is damaged?	7:56
What should I do if a label is damaged?.....	7:56
How do I update the exhibit?	7:57
Q. Selected Bibliography	7:57
R. List of Figures	7:58

CHAPTER 7: USING MUSEUM COLLECTIONS IN EXHIBITS

A. Overview

1. *What information will I find in this chapter?*

This chapter explains how you develop exhibits that feature museum and archival collections. It outlines the steps that you need to take when you develop and install an exhibit, or when you arrange for the exhibit of park collections.

Although many of the principles outlined in this chapter apply to the presentation of museum collections in most types of exhibits, the chapter doesn't specifically address the following:

- collections on exhibit in furnished historic structures
- exhibits without original museum objects, specimens or archival items, such as two-dimensional poster, panel, or World Wide Web exhibits
- mobile or outreach exhibits
- office art or display of museum collections in administrative offices
- visible storage
- wayside exhibits
- traveling exhibits initiated by the park

Refer to Chapter 8 for information on furnished historic structures.

2. *What is a museum exhibit?*

A successful museum exhibit tells a good story. The exhibit connects to viewers through objects, label copy, dioramas, exhibit props, and other resources. It ensures the display of collections according to a selected rationale. Effective display techniques transmit exhibit themes and ideas. Labels give meaning and context to the exhibit. Generally, exhibits are developed through study and research of the subject and related collections. Exhibit curators select and arrange objects, specimens, images, and documents to illustrate the exhibit themes. A museum exhibit should facilitate a productive encounter between the object and the visitor. It should encourage learning and inquiry. An effective exhibit gives reign to the visitor's imagination. It should create a direct link to an authentic past, a sense of immediacy and intimacy. Exhibits should provide a deepened understanding and appreciation of a particular individual, people, places, structures, objects, processes or an event, or a habitat, including flora, fauna, and geology.

3. *Why does the NPS produce exhibits?*

Exhibits are the primary and traditional means by which the park museum reaches its public. Exhibits allow visitors to learn about park resources. Park exhibits communicate information, concepts, ideas and stories about people, events, activities, or the natural world that a park commemorates or preserves. NPS exhibits provide the “real thing,” or the original object in context or in the place where people lived or worked, where events took place, or where the animals roamed or the specimens were collected. Public displays allow NPS staff to present the latest research on the park’s resources and reach diverse park audiences. They should engage visitors in meaningful dialogue about issues pertinent to the museum’s mission and goals. NPS preservation, collections management, research, and education goals are achieved through exhibits.

2. *Why should I use museum collections in exhibits?*

In addition to information provided by exhibit labels, objects themselves have the power to transmit a range of meanings. When you put a museum object on exhibit, you allow viewers to see the “real thing” rather than a reproduction, virtual object, or image of the item. The real object fires the imagination. Paul Perrot, in *The Smithsonian Experience* (1977) made the definitive statement on why museum objects should be used in exhibits:

"Collections are the raison d'être of museums. They are the source from which the museum's unique role in the cultural fabric of society emanates. They are the basis of its contribution to scholarship, the instruments of its education role, and the cause of its public enlightenment."

The opportunity to experience and encounter an authentic object from another time and place is invaluable. A museum object is powerful because it provides a tangible connection to a time, place, event, or person. The museum object is documented as being associated (“being there”) with or used by an eminent figure at a particular time and place. The specimen, plant, or animal actually existed in what is now the park, in the recent or distant past. The “real” object communicates directly to the visitor, providing a direct link to another time. Exhibits of museum collections provide the visitor an opportunity to see original items that are directly associated with the park and the values it is dedicated to preserving.

B. Finding Background Information

The park’s enabling legislation, park history, interpretive planning documents, and other park documents often yield exhibit background information and very often, an exhibit subject. The park documents noted below may provide you with information useful for developing a park exhibit.

1. *How do I identify the need to develop an exhibit?*

The need to develop a park museum exhibit is noted in several NPS documents. The park usually initiates the exhibit based on the need

identified in one or more of the following documents:

- Congressional mandate establishing the park.
- *NPS Management Policies*, Chapter 9: Visitor Facilities, indicates that visitor centers, including museums and exhibits are necessary for a quality visitor experience.
- *General Management Plan (GMP)* outlines interpretive themes, proposes locations for informational and interpretive facilities, examines visitor needs and use trends, and sets the general direction for resource interpretation, preservation and visitor use.
- *Comprehensive Interpretive Plan (CIP)* identifies all interpretive themes and needs in the park and includes a long-range interpretive plan or strategy, the annual interpretive plan, and a park interpretive database that compiles various interpretive data.
- *Long Range Interpretive Prospectus (LRIP)* that is part of the CIP, is developed for a specific project. See B.2. for additional information.
- *Interpretation and Visitor Services Guideline* (formerly NPS 6), Chapter 5, Section 2, Exhibit Design, Production and Rehabilitation discusses the development or rehabilitation of exhibits.

2. *What NPS documents have information I can use to develop an exhibit?*

The following NPS documents contain information about various aspects of planning and implementing NPS museum exhibits.

- *General Management Plan (GMP)* outlines interpretive themes, proposes locations for informational and interpretive facilities, examines visitor needs and use trends, and sets the general direction for resource interpretation, preservation, and visitor use.
- *Historic Structures Report* includes information on the historical evolution of a historic structure and recommendations for treatment and use.
- *Historic Furnishings Report (HFR)* provides information on the principal occupants or users of the structure, periods of use, and significant events that occurred at the site. It includes available information on the original historic furnishings of a particular room, rooms, or an entire structure. Historic photographs and inventories provide supporting evidence, and are used to furnish the room or structure. It also contains information on the interpretive objectives of the room or structure and the historical occupancy of the site.
- *Historic Resource Study* provides information on all of the park's historic resources, including historic structures, archeological sites, and museum collections.

- *Scope of Collection Statement* is the basic document that outlines the scope of the park's museum and archival holdings at the present, and for the future. It outlines the topical or thematic coverage, key groups and individuals, activities and events, geographic focus, and time period to which all collections must relate. It describes the types of objects that should be acquired for the collection. For additional information, refer to *MH-I*, Chapter 2: Scope of Museum Collections.
- *Long Range Interpretive Prospectus* (LRIP) identifies specific interpretive themes and objectives. It makes recommendations concerning appropriate media to blend the park's interpretive program into a coherent whole. The LRIP is a long-term strategic plan that forms the basis for all park interpretive actions. The LRIP outlines the park's primary interpretive themes and messages park management wants to impart to every park visitor. The LRIP outlines significant park resources and gives the park's legislative history.

The park's thematic and interpretive messages are multi-disciplinary. Visitor services include museum exhibits, historic furnishings, wayside exhibits, multi-media, features, and talks and walks. The LRIP identifies actions needed to achieve those goals. For additional information, refer to the *Interpretation Guideline* (formerly NPS 6) and the *Planning for Interpretation and Visitor Experience* document prepared by the Department of Interpretive Planning, Harpers Ferry Center (HFC), 1998. Both documents can be downloaded from the Web at <<http://www.nps.gov/hfc>>.

3. *Where do I go for help when planning an exhibit?*

When you initiate a new exhibit or update an existing one, you should consult with your regional/support office (SO) curator and HFC, Department of Exhibits, and Department of Conservation staff (<<http://www.nps.gov/hfc>>). HFC staff can provide you with useful advice and information about a broad range of exhibit and conservation-related activities and services, including contracting with a conservator or exhibit design companies.

- *Harpers Ferry Center, Department of Exhibits*

HFC, Department of Exhibits services include planning, consultation, development, design, fabrication, production, and installation, as well as developing a request for proposal (RFP), and managing a contract for the park. The park usually enters into a project agreement with HFC. The project agreement outlines the role that the park, HFC, or a design and planning company will have in the planning, development and installation of the exhibit. See Figure 7.1, Sample Project Agreement between the Park and Harpers Ferry Center, Department of Exhibits. If the park plans to contract for exhibit services, then the request for proposal (RFP) outlines the exhibit's educational

goals, the look and feel of the exhibit, selection criteria, and exhibit experiences the park wants the visitor to have, as well as pertinent references.

You can find information and related software on exhibit planning, planning and design specifications, fabrication specifications, exhibit numbering system guidelines, and NPS indefinite delivery, indefinite quantity (IDIQ) contracts at <<http://www.hfc.nps.gov/>>.

- *Harpers Ferry Center, Department of Conservation*

HFC, Department of Conservation can provide you with exhibit conservation information. Consult with staff when you select objects for exhibit to determine whether they will need conservation or treatment. HFC staff can either perform the work for you, or recommend conservation contractors to do the work. The Conservation Department treats and stabilizes objects for display; provides technical review of exhibit plans; reviews and recommends materials and environments for exhibits; fabricates mounts for objects; and travels to sites to install artifacts. Refer to *Exhibition Guidelines: Incorporating Conservation into Exhibit Planning and Design* prepared by HFC, Department of Conservation at <<http://www.hfc.nps.gov/>>. For information to help insure preservation of objects on exhibit, refer to Section E and to the bibliography in Section M. *MH-I* and the *Conserve O Gram* series also provide extensive information on object preservation, lighting and relative humidity, and mounting techniques.

- *Museum Colleagues*

You'll also gain valuable practical advice by talking to curators at local museums and historical societies and to NPS colleagues who have developed and installed exhibits or coordinated the development and installation of exhibits.

Before you approach a contractor, consult with HFC exhibit and conservation staff and colleagues who have installed exhibits. They can give you useful advice, suggestions, and names of possible contractors.

4. *What steps do I need to take to develop an exhibit contract?*

An exhibit contract should contain the steps outlined below. The contract should also identify who is responsible for each phase of the project:

- ***Exhibit mission statement:*** The mission statement identifies the exhibit goal. It can be a short paragraph, outline, or a detailed description. The exhibit mission statement articulates the common vision held by park museum management and staff. The process of developing a mission statement ensures that there is ample discussion about the exhibit, and that all involved share the common goal. It can do much to cut down on the need for

changes once the work on the exhibit has started.

- **Scope of work:** The scope of work includes:
 - design firm or contractor’s tasks
 - task specifications
 - deliverables, such as cases, mounts, materials, and exhibit furniture
 - structural requirements such as walls, beams, and stability of cases
 - safety requirements, including adherence to all codes such as wiring
 - performance criteria
 - performance time frame
 - evaluation criteria
- **Inspection schedule:** Make sure that a qualified individual does the inspection.
- **Project schedule:** Divide the work and deliverables into achievable phases.
- **Budget**
- **Payment schedule**

Refer to Figure 7.2, Sample Fabrication and Installation Contract Wording, for sample wording to include in an exhibit contract.

5. *What’s the park’s role in determining who’ll work on an exhibit?*

The park, as the initiator or “owner” of the exhibit makes the critical decisions about the exhibit. Park management determines whether park staff, HFC, Department of Exhibits, or an outside contractor, or a combination of the three, will work on the exhibit and the role of each. When determining how involved park staff will be, the park needs to consider whether there’s sufficient park subject-matter expertise, exhibit development experience, and park staff availability. The exhibit project coordinator, who oversees all aspects of the exhibit, can be a park staff member, HFC exhibit curator, or a member of a contract exhibit design and planning firm.

When evaluating potential proposals, the park should get satisfactory answers to some of the following questions:

- How well does the contractor communicate exhibit themes?
- Is the exhibit creatively designed?
- Does the exhibit use a variety of material and media?
- Are diverse audiences sensitively handled, including special populations?
- How easily can the exhibit be maintained?

C. Getting Started

1. *When do park exhibits happen?*

Park museum exhibits provide an ideal medium for sharing park resources and research with the general public and special interest groups. They allow the park to meet its legislative, interpretation and education mission. Parks initiate exhibits to interpret park resources, including museum collections. A park museum exhibit may be triggered by one of the following:

- new visitor center opening
- rehabilitation of an existing installation
- new discoveries or interpretation of park resources, including museum and archival collections
- special events
- commemoration of a significant donation to the park collection

The park usually seeks line item funding to do an exhibit, although cooperating associations and other sources may also fund exhibits. Refer to Figure 7.3, Park Exhibit Checklist, for an outline of the steps involved in developing and installing an exhibit.

2. *What kinds of museum exhibits are there?*

There are many kinds of exhibits. Exhibits can be long-term or temporary. Generally, temporary exhibits range from a few months to three years and can include display of park collections, borrowed objects, or traveling exhibits. Long-term exhibits last longer and temporary exhibits are often extended. If your park has an exhibit that will be up or has been up for an extended period, you need to make a special effort to ensure the well being of the objects on exhibit. Work with a conservator to arrange for frequent object rotation and conservation of objects, to create optimum exhibit conditions, and to provide a post-installation maintenance, monitoring and inspection schedule. Refer to Section H for information on exhibit conservation. You also need to make provisions for the study of objects on exhibit, and if necessary, the loan of items on exhibit to other museums for the duration of the

exhibit.

Regardless of duration, exhibits on selected topics may feature items from the park museum's collections. They can also be supplemented by objects borrowed from other museums. Other special exhibits may be displays obtained from traveling exhibit services or loans from another institution. Exhibits can be:

- thematic, such as U.S. Presidents or the Uniforms of the Civil War
- systematic, such as Rhododendrons of the Great Smoky Mountains
- material-oriented, such as Survey of Pueblo Ceramics or Prehistoric Tools of Tennessee

Long-term and temporary exhibits can be one or a combination of the exhibit types noted above. However, all exhibits have some things in common. All exhibits need a design and circulation layout, although they may use a variety of display techniques. All exhibits must convey information. Exhibits should involve multi-sensory experiences, appeal to different learning styles, and make good use of a well-maintained multi-media technology.

3. *What types of exhibits will fit my park's exhibit needs?*

The type of exhibit you choose to do will depend on what the park needs. Evaluate available resources, including staff and funding, as well as the time required to develop, produce, and install the exhibit. Different kinds of exhibits include:

- new long-term exhibits
- rehabilitated exhibits
- temporary exhibits
- off-site exhibits developed by the park
- traveling
- single venue
- school exhibits
- free-standing exhibits
- table-top exhibits
- recent acquisition exhibit
- featured collections case (such as "treasures from the park collections")

4. *What materials, media and resources do park exhibits contain?*

Traditional exhibits, as opposed to virtual or electronic exhibits, include some of the following:

- selected collection materials, such as:
 - cultural objects
 - natural history specimens
 - archival or manuscript materials
- individual captions
- label copy that conveys the intellectual content, themes and concepts of the exhibit
- graphics and artwork developed or reproduced expressly for the exhibit
- reproductions
 - two-dimensional reproductions, such as images and documents
 - three-dimensional reproductions of specimens or objects
- multi-media
 - audiovisual programs
 - interactive devices
 - computer programs
- dioramas
- mannequins
- exhibit furniture (props), such as stands and brackets

5. *Who should be on the park exhibit team?*

An effective and productive team includes the right people with the appropriate skills. A successful team needs management support. If the park is developing an exhibit, it is important to establish an exhibit team. Make sure museum, interpretation, conservation, and maintenance staff are on the team. Not only does the exhibit need staff input during development and installation, it will need maintenance and interpretation. The team also needs to draw on the expertise of researchers, students, and affiliated groups at all phases of planning and development. While the exhibit curator and exhibit designer are usually take the lead, the exhibit team may include any of the following:

- park staff

- curator or staff person responsible for the museum and archival collections
- chief of interpretation
- chief of maintenance
- chief of resources management
- chief ranger
- subject matter experts such as the archivist, archeologist, biologist, ethnographer, historian, geologist, librarian or paleontologist, as appropriate
- superintendent
- exhibit specialists (NPS park, HFC or non-NPS contractors)
 - AV producer
 - conservator (refer to Section H, Exhibit Conservation, and Section I, Preserving and Protecting Objects in the Exhibit Process)
 - designer
 - exhibit producer
 - planner
 - writer/editor
- regional/support office staff
 - regional/support office curator
 - chief of interpretation
 - historical architect
 - regional historian, archeologist, ethnographer or scientist, as appropriate
- non-NPS specialists (can consult at the park, region, or center)
 - architecture and engineering (A&E) professional
 - educator
 - community and affiliated group representatives

- conservator
- construction consultant
- media specialist
- subject matter experts
- visitor advocate

Because the NPS exhibit team is usually large and geographically dispersed, the project coordinator needs to:

- manage multiple tasks simultaneously
- have good people skills
 - know how to successfully coordinate diverse individuals to achieve a common goal
 - motivate team members
 - have strong negotiating skills
 - maximize the contributions of each team member
 - consult with appropriate park staff and other professionals
- know how to manage a budget
- be experienced and knowledgeable in all aspects of exhibit development and installation
- know how to obtain necessary resources
- be goal oriented
- meet deadlines

6. *How can a team work most effectively to prepare an exhibit?*

Successful exhibit design and installation is a team effort and a major undertaking.

The exhibit process involves many different tasks, including:

- planning
- development and design
- production
- installation

A well-functioning team ensures:

- the exhibit goal is developed
- high caliber research is done
- sufficient resources are available
- the right skills are used in all phases of the project
- diverse opinions are heard
- creativity is encouraged
- all the necessary work gets done
- the “message,” theme, and sub-themes are communicated to the viewer
- appropriate museum collections are selected for display
- the exhibit is attractive
- the exhibit opens on time
- the exhibit is publicized and well attended

D. Defining the Purpose and Audience

1. *What steps do I take to develop exhibit themes and goals?*

Generally, your park identifies the broad exhibit topic. The theme should relate to the park mission in a meaningful way. The exhibit team is then charged with forging a cohesive story line for the exhibit. Specific sub-themes that expand and interpret the primary theme are identified. Individual team members are assigned specific tasks. The team as a whole evaluates individual components and tasks.

To develop the themes, the team or an assigned team member should take the following steps:

- *Identify exhibit themes.* The team brainstorms and identifies several exhibit themes that would further the park’s interpretive and education goals. The topics should expand the visitors’ understanding of the park’s mission and resources.
- *Select a specific exhibit theme and objective.* The team selects the most appropriate and timely theme based on available resources, including collections and staff time. The team decides what message and concepts the exhibit should convey.

- *Develop an exhibit proposal.* The exhibit proposal provides a comprehensive overview of the exhibit themes and sub-themes. It states what experiences the visitor should have going through the exhibit and what learning should take place. The proposal includes a general description of what objects and images will be exhibited and information on potential partners and cooperators. It describes the audiences it expects to reach. Public programming, including interpretive programs, accompanying brochures and catalogs, educational packages, and a Web-based version of the exhibit are described.
- *Identify what the park's role will be* in consultation with the park management and staff. The park chooses whether to develop the exhibit in-house, contract out directly with an exhibit curator and a design firm, or enter into an agreement with HFC to manage a contract to develop the exhibit.
- *Establish what resources the park will provide,* such as curatorial staff to do research and write exhibit label copy and maintenance staff to build exhibit cases or install lighting. The park may choose to have a limited role in the development of the exhibit and have HFC coordinate the entire process of development and installation. In this event, the park may just provide a park liaison to monitor a cooperative agreement with HFC. The exhibit should showcase the park's collections, as well as other park resources. If necessary, the park may be able to borrow material to supplement the exhibit. However, you need to make sure that the park can provide security, insurance, and optimum exhibit and handling conditions for the loan.

Refer to Figure 7.3, Park Exhibit Checklist, for a listing of exhibit-related activities.

2. *How do I conduct research for an exhibit?*

If you're going to be involved in designing and developing an exhibit, you will need to do research and collect information that will be used in the exhibit design. Before you start doing research, establish what story you want your exhibit to tell. Take the following steps:

- Identify the exhibit topic.
- Read background information on the topic, including park interpretive planning documents. Refer to Planning for Interpretation and Visitor Experiences, prepared by the Division of Interpretation.
- Review your park's interpretive plans and refer to DO #6, Interpretation and Education, Section 5, Interpretive Planning guidelines
- Research the most current scholarship by:

- consulting with a librarian or an archivist
- using the World Wide Web to track down information on the exhibit and related themes
- conducting a search of library and exhibit catalogs, bibliographies, sources and materials
- reading the pertinent literature
- visiting virtual museum exhibits on the World Wide Web
- Develop exhibit sub-themes.
- Identify appropriate objects in the park collection.
- Study object documentation.
- Discuss the proposed topic with curators of similar collections and exhibits.
- Consult with subject matter specialists.
- See museum exhibits and historic house installations.
- Obtain materials analysis where necessary.
- Study collections at other institutions.
- Appoint a working group that includes diverse points of view, especially those who have a stake in the exhibit.

For detailed information on how to conduct bibliographic research, refer to Chapter 9: Bibliographic Research, and Chapter 3: Publications, Section E.13, What should I do to prepare a publication?

3. *How do I define the target audience?*

There have been relatively few studies on identifying and reaching target audiences. Useful information often is scarce and targeting audiences can be quite complex. However, the exhibit team can identify target audiences based on the exhibit theme and subject matter. Certain themes will have certain affinities with specific target groups; for example, an exhibit on camp life at Gettysburg will attract Civil War buffs. However, the same exhibit can be expanded so that it is more appealing to broader audiences and other target groups. The exhibit could include a view of community and social life during the Civil War, the role of women and African Americans, and an exploration of photography of the period. A study guide for different grade levels will attract a wide range of students and teachers. Consult with other museums, historical societies, and

visitor bureaus for an analysis of local and regional tourism and museum visitation trends. Consult with interpreters to better understand park visitor demographics.

4. *What should I know about park museum visitors?*

Getting to know your visitors is a challenging task. Museum visitor studies can yield useful information that exhibit planners and designers should incorporate into planning efforts. Visitors are not a homogenous group. They reflect age, gender, education, socio-economic, and ethnic differences. Visitors have different perspectives, learning styles, and expectations. Studies also indicate that many visit exhibits in groups (often in a family group with children), rather than alone. Different groups behave differently in the museum setting.

Several studies indicate that visitors tend to spend little time reading label copy. Studies also indicate that visitors typically spend less time per unit area in larger exhibits than in smaller exhibits, and that they don't stay in the exhibit gallery too long (usually not longer than 20 minutes, if that). In order to "grab" the visitor's attention, spaces have to be well designed and imaginative and the right objects exhibited with brief and clear labels.

It is important to get ongoing feedback from visitors. The park needs to be "self-correcting," that is, staff should rework interpretive labels, brochures, and exhibits in response to visitor feedback where possible. Refer to Section P. Rehabilitating Exhibits, for further information on updating park exhibits. Analyzing visitor information allows the park to develop well-targeted interpretation and public programs and to plan effective exhibits:

- Track the number of visitors to the museum.

NPS visitor and other personnel collect public use information through a variety of means, such as:

- recording each individual visitor using a hand counter
- logging in the number of people taking a guided tour
- reading traffic counters or electric eyes
- observing vehicles in the parking lot at specific time periods
- contacting concessionaires for their data

The park records the data into a database. The electronic file is transmitted by the 15th of each month to the NPS Public Use Data mailbox.

- Obtain a general visitor profile with pertinent demographic information (such as age, gender, education) to the extent permitted by law.

The NPS had occasional visitor studies done as early as the 1950s. The Visitor Services Project (VSP) was initiated in 1982. The project, supported by the NPS Department of Interpretation, Washington, DC, provided the first sustained series of visitor studies in 1985. In 1996, the project focused on the GPRA customer service card, which became operational in 1998. Refer to *Serving the Visitor 1998, A Report on Customers of the National Park Service, The NPS Visitor Services Project*. The NPS Visitor Services Project led by the NPS Chief Social Scientist conducts two surveys that yield information on visitors:

- *Visitor Studies*

The annual park *Visitor Study* was introduced in the late 1990s. The NPS Chief Social Scientist coordinates ten park surveys a year. The study seeks answers to specific questions. Standard multiple choice questions include queries on visitor satisfaction with park personnel, visitor centers, directional signs, facilities, ranger programs, exhibits, park brochures, and concession services. The *Visitor Study* includes a standard exhibit satisfaction question about the quality of exhibits. The park can commission additional park-specific questions concerning exhibits or any other matters to solicit detailed information that can be used when planning new or rehabilitating existing exhibits. Consult with HFC, Department of Exhibits for additional information on exhibit visitor surveys.

- Customer Satisfaction Card Surveys

The Customer Satisfaction Card Surveys or visitor survey card was developed in response to the Government Performance and Results Act (GPRA). It measures visitor satisfaction with NPS park facilities, visitor services, and recreational opportunities.

5. *What special population issues do I need to consider?*

Your park exhibit should reach a wide range of diverse communities. In particular, work with exhibit and maintenance staff to make sure that needs of special populations are addressed by actions such as these:

- For the mobility impaired, place labels, objects, videos, and controls at a height that can be easily read by wheelchair-bound visitors. Ensure that:
 - exhibit spaces are free of architectural barriers or provide alternative means to view exhibits
 - pathways, aisles, clearances, ramps, and floors meet acceptable standards
- For the visually impaired, provide labels with large fonts, use

colors that are easily readable, and minimize unnecessary glare.

- For the hearing impaired, provide accompanying written or illustrated text for audio portions of the exhibit.
- For the learning impaired, provide supplementary material or interpretation to potentially challenging exhibit concepts.

Refer to DO #16A: Reasonable Accommodation for Applicants and Employees with Disabilities, and DO #42: Accessibility for Visitors with Disabilities in National Park Service Programs, Facilities, and Services for Americans with Disability Act (ADA) guidelines on access to exhibits.

6. *Should the local community be involved with the exhibit?*

Yes, community involvement is strongly recommended. Consult with the local community, and other affiliated and interested groups throughout the planning, development, and installation of an exhibit.

You should have access to community opinions through a named community representative on your exhibit committee, if possible. Make sure that the specific (named) representative is willing to stay through the whole process or arrange to have an alternate. If you're working with a community group, provide the members with guidelines that define their role, explain how conflicts will be resolved, and that indicate that the ultimate decision rests with the park. Once you've consulted with community representatives, every effort should be made to address their concerns. If some concerns can't be adequately addressed, then management should explain to the group how and why the park has decided to proceed.

E. Planning and Designing Exhibits

Exhibits require a balance between the competing demands of preservation and use. The exhibit should never subject the object to unacceptable wear and tear (see Section H, Exhibit Conservation, and *MH-I*, Chapter 3: Preservation: Getting Started).

Planning successful exhibits demands a close, constructive working relationship between curatorial, archival, interpretation, exhibit, and conservation specialists. Exhibit design and conservation recommendations should be realistic and pragmatic. As the collections advocate, you should be involved in, or review all phases of exhibit development. Make sure that the park's interpretive mission is met. In addition to selecting the "right" objects for exhibit, make sure that the exhibit environment doesn't harm the objects on exhibit. Work with appropriate specialists to make sure the concerns are addressed.

1. *Are there policy issues to be considered?*

You need to consider these factors when planning the exhibit:

- Don't exhibit Native American human remains, refer to Management Policies, Chapter 5. **Note:** Exhibit of non-Native

American human remains is not prohibited.

- Don't exhibit materials subject to the Native American Graves Protection and Repatriation Act (NAGPRA) materials without consultation with affiliated group(s). Refer to *Management Policies*, Chapter 5, p.11, and *Cultural Resource Management Guideline* (formerly NPS-28) for information on consultation.
- Don't exhibit materials with privacy, confidentiality, obscenity, unresolved sensitivities or legal restrictions or issues (refer to Chapter 2: Legal Issues).
- Consult with traditionally affiliated groups regarding the items you propose to exhibit.
- Consider the concerns of affiliated groups regarding the exhibit, objects, and the installation.
- Seek input from affiliated or affected groups before displaying sensitive items.
- Determine, where possible, what culturally sensitive items can be exhibited in association with other items.
- Make sure that the exhibit is clearly demarcated and separate from the concession store or park gift shop to avoid creating an impression that collections are available for sale.

2. *What are the overall planning and design strategies?*

These are the basic strategies:

- Select only those objects that will enhance the exhibit for display. Remember that you want to 'show' the exhibit in the most effective visual way possible.
- Integrate conservation concerns early in the exhibit planning phase.
- Develop and review technical designs, case prototypes, lighting mockups, and results of materials tests.
- Plan and budget for safe handling, exhibit mount making, and installation of objects.
- Use designers experienced in developing effective exhibits.
- Use designers and firms experienced in producing preservation-responsible exhibits.
- Plan for comfortable traffic flow through the exhibit and around exhibit cases.

3. *What are the overall preservation and protection*

These are the basic strategies:

strategies?

- Incorporate conservation recommendations into the exhibit design.
- Select stable objects.
- Involve an exhibit conservator in all phases of work.
- Design for environmental stability and protection.
- Allot sufficient time and resources to safely prepare, mount and install objects.
- Select practical conservation approaches, such as grouping objects with similar conservation needs.
- Accommodate fragile items, such as pastel drawings and photographs, through rotation or reproduction.
- Rotate and rest sensitive objects in long-term exhibits.
- Don't overcrowd exhibit cases.
- Complete a written condition assessment of each object.
- Develop a practical exhibit installation proposal for objects that will be exhibited.
- Secure the necessary funding for treating unstable objects before exhibit.
- Stabilize or treat all objects as needed.
- Address other related preservation requirements such as:
 - secure mounting
 - ongoing monitoring and inspection
 - maintenance

4. *What are the collection management priorities?*

Collection management priorities:

- Use a dedicated, clean, and secure space for temporary housing of objects during exhibit development, construction, and installation.
- Protect objects during record, exhibit and condition photography.
- Limit an object's total exposure to harmful light wavelengths.
- Avoid overheating objects with studio lights or a flash system, especially for light-sensitive objects.

- Ensure safe installation of objects.
- Record exhibit status and information in the Automated National Catalog System (ANCS+).

5. *What factors should I consider when selecting objects for exhibit?*

The exhibit theme and sub-themes provide the initial selection criteria when you first consider collections for inclusion in the exhibit.

- List the objects related to the theme. Wherever possible, use items from the park's collections.
- Refine the list to the number of objects appropriate to the space.
- Ensure relative sizes of objects are compatible in space; make substitutions if necessary.
- Ensure environmental requirements of selected objects are compatible and can be met; make substitutions as necessary.
- Consult with affiliated groups.
- Identify alternate objects for rotation.

6. *What is the project coordinator's role?*

The exhibit project coordinator oversees all aspects of exhibit planning, production, and installation. The coordinator makes sure that the terms and specifications of the contract(s) are implemented and that installation proceeds according to the schedule laid out in the final planning notebook and design drawing. Refer to Figure 7.3, Park Exhibit Checklist, for a listing of exhibit activities.

7. *What steps does the team take to plan and design exhibits?*

To plan and design an exhibit, the team:

- determines the emphasis of themes
- identifies how to transmit themes and goals to audience
- develops written strategy to communicate significance of collections
- identifies educational strategy
- solicits ideas
- shares information
- voices and addresses concerns within the team, and if necessary, with park management
- develops the exhibit schedule
- gathers all pertinent visitation data

- surveys the resource materials in park files and library
- reviews local community, museum, historical society, and college resources
- prepares a list of subject matter reference material
- determines the general requirements for staffing and security
- examines the existing conditions (visitation levels, climatic conditions, seasonal closings) that may impact objects on exhibit
- determines the requirements and programs for disabled, visual and hearing impaired, and other physically challenged visitors
- visits and inspects the exhibit site
- reviews the collections, including documents, graphics, and photographs
- writes text and selects graphics
- develops a preliminary list of museum objects, specimens, and archival materials for display consideration
- identifies the preservation needs of items to go on exhibit (refer to Section H)
- determines, in consultation with the conservator and exhibit designer, the overall design, mounting, cases, monitoring and maintenance of items going up on exhibit (refer to Section J)
- works with maintenance staff to incorporate the exhibit into the park maintenance, security, fire, and emergency operation plans
- works with the exhibit contractor to develop the exhibit maintenance manual (see Section O.2)

You, the project manager and/or museum curator, need to evaluate continually the exhibit team's performance. You need to review the exhibit process. Evaluate all phases of exhibit development and installation. Incorporate recommendations throughout the process. Make improvements and adjustments to the exhibit process for the next project. Assess how well the final exhibit meets the stated goals.

8. *How do I write effective museum exhibit label copy?*

Museum labels are graphic communications that deliver their message by means of words, symbols, art, photographs, and other visual images. Creating effective exhibit label copy involves research, writing, editing, rewriting, design, and layout of the copy. These one-of-a-kind labels are usually in place for a considerable time. Successful and well-written labels will be seen by many people. Exhibit labels convey themes, concepts, ideas, and information about

the exhibit and collections that are on display. Without accompanying museum labels, exhibited objects, specimens, and archival items tend to become purely decorative or can be misinterpreted. Effective copy must be interesting, easy-to-read, and readily understandable. Exhibit labels must convey the essence of your exhibit theme. Exhibit labels should connect with multiple and diverse audiences. Effective exhibit labels should communicate information and tell a story to visitors.

Surveys and questionnaires, interviews or observations of people's behavior and learning styles help you to develop clear and objective labels that meet the needs of your park's visitors. Each exhibit label should have its purpose clearly defined before writing begins. Some of the questions you should ask include:

- Why is this label needed?
- Does the label do what is it supposed to do?
- How does it identify questions to be asked and answered by the exhibit?
- What are the different types or levels of exhibit labels? They include:
 - exhibit title or headline, which announces the exhibit
 - subhead or sub-theme label, which announces the theme and sub-themes, and clarifies the title
 - introductory label, which provides information about the exhibit theme, collections, and concepts to the visitor; also outlines main themes, sub-themes, and background
 - group labels, which focus on similar objects, specimens, or items and interpret similarities apparent in the collection
 - captions that interpret single items and contain concrete and specific information

When writing caption labels, follow the format described in Chapter 3, Publications, Section E.18, What do I need to know about writing captions?

Good exhibit labels should be:

- brief
- clear
- simple (not simplistic)
- accurate

- legible for all to read, including the visually impaired (work with the exhibit designer to use readable fonts)
- linked to other labels in the exhibit
- appropriately placed in the exhibit

Good label copy techniques include:

- asking questions and providing the answers
- using colloquial expressions
- using apt quotations
- drawing comparisons
- relating to common visitor experiences
- engaging the visitor to find, compare, or interact

Effective writing includes:

- telling a good story
- being conversational
- starting with visual observable interpretations and facts about objects
- using word pictures or verbal illustrations
- personal pronouns such as “you” and “we”
- using active verbs
- avoiding pompous or overly technical language
- keeping sentences short (under 25 words long)

Parks can develop content material and drafts. However, HFC recommends that parks have professional exhibit writers prepare final exhibit copy. Contact HFC, Department of Exhibits for referrals on potential contractors to research and/or write exhibit label copy. Make sure that you, professional colleagues, and subject matter specialists review the label copy.

F. Producing and Installing Exhibits

1. *What steps are involved in exhibit production and installation?*

The steps in production and installation include:

- implementing contract specifications and drawings
- rehabilitating the existing building or doing new construction
- working with the park contracting officer to obtain bids for the project
- awarding the contract
- managing the contract
- coordinating the exhibit fabrication
- inspecting the:
 - exhibit spaces
 - structure
 - system power and electrical systems
 - mechanical systems
- supervising construction of:
 - cases
 - mounts
 - exhibit furniture
- monitoring conservation and preparation of objects selected for exhibit
- photographing objects for an exhibit or publication
- installing objects
- supervising exhibit installation
- checking environmental conditions inside and outside cases
- checking security
- photographing exhibits for documentation and security

2. *What are the “closeout” steps before opening an*

Work with HFC and park contracting officer to make sure the following steps have been taken when the exhibit is nearing

exhibit?

completion:

- Verify that all contract specifications have been satisfactorily met.
- Develop a punch list of problems to be corrected.
- Collate the maintenance manual (see Section O.2) and:
 - place a complete maintenance manual in secure museum storage
 - remove the maintenance manual security section and restrict access to it by placing it in a sealed envelope in a locked safe
 - provide the maintenance manual, without the security section, to the park library
- Provide maintenance training to appropriate staff.
- Amend the park fire protection plan and emergency operation plan to include the new exhibit.
- Obtain a repair kit from the exhibits producer.
- Get a full set of keys, codes, and tools for the supervisory museum curator and follow key access procedures outlined in *MH-I*, Chapter 9, Section E.7, What should I do to safeguard keys?
- Inspect the entire exhibit.
- Obtain a closeout package of all pertinent materials and information, and place with park museum records.
- Do a final walk-through with the exhibit team, appropriate park staff and the exhibit coordinator/project manager.
- Make sure all problems noted on the punch list are corrected before accepting the work and acknowledging completion.

The superintendent, chiefs of interpretation and maintenance, and the museum curator should do a walk-through inspection at the exhibit closeout.

G. Exhibit Planning, Design, Production and Installation Documents

The information in this section describes documents and procedures developed by HFC. However, professional service providers should

follow similar procedures and develop similar documents for the park.

1. *What planning and design documents do I need?*

There are usually three broad phases of exhibit planning and design. These phases are reflected in the following documents:

- schematic plan and design
- concept plan and design
- final planning notebook and design drawing

For detailed information on planning and design and fabrication specifications, refer to documents developed by HFC, Department of Exhibits, *NPS Standard Planning & Design Specifications*, February 1998 and *NPS Standard Fabrication Specifications*, July 1997, and the *Museum Exhibit Planner*, Application Software for Planning National Park Service Exhibits. These documents are available on the Web at <<http://www.cr.nps.gov/hfc>>.

2. *What does a schematic plan and design include?*

The schematic plan and design includes broad narrative descriptions of exhibit themes and objectives identified in the Interpretive Prospectus, and the types of collections to be exhibited. The plan reflects general ideas about the exhibit. Exhibit label copy or text isn't included in this phase. The following are included in the schematic plan and design:

- floor plan
- bubble diagram indicating the general orientation of exhibits
- rough titles that reflect ideas and themes
- rough placement of exhibit and exhibit cases
- broad description of object types to be included in the exhibit
- general discussion of exhibit media and elements, such as audiovisual or interactive media

The schematic plan and design work is usually contracted out. The contractor develops several versions of the plan. The exhibit designer and planner, and the park review each version of the plan. For additional information refer to Figure 7.1.

3. *What does a concept plan and design include?*

The concept plan and design are based on the schematic plan and design. At this stage, change is still possible. Themes and objectives can be modified or revised. Exhibit plans can be retooled. As with the schematic plan and design, there is usually a preliminary and a final version of the concept plan and design. The park closely reviews all versions of the concept plan and design. The concept

plan and design gives a general, rather than detailed view of what the exhibit will look like. It contains all the elements that make up the exhibit. See Figure 7.1 for the detailed information on a concept plan and design.

The park reviews the document to:

- ensure that appropriate goals and themes are covered
- change the emphasis of some exhibit elements, if needed
- review the park role and resource commitment to project, including staff availability
- review objects selected for exhibit. *Note:* For easy reference, make sure that catalog numbers are included in the plan together with the HFC tracking numbers

Edits are incorporated. The concept plan and design are turned over to the exhibit designer. The exhibit designer then refines the exhibit layout and design. For additional information refer to Figure 7.1.

4. *What does the final planning notebook and design drawing include?*

Once the concept plan and design are approved, the exhibit development process moves into the final phase. This phase also can have several sub-stages. Each version of the final planning notebook and design drawings is reviewed and commented upon and the edits incorporated. Because of the extensive planning and review cycle, there should be very few corrections needed at this point. *Note:* For easy reference, make sure that catalog numbers are included in the plan together with the HFC tracking numbers.

The last or final version of the planning notebook and design drawing is also called the “production ready plan and design.” It is put out to bid. Once a contract has been awarded to a design planning and installation firm, changes can’t be made without incurring considerable cost to the park. The final planning notebook includes the finalized version of elements that were outlined in the concept plan and design. These are the requirements for the contract. Refer to Figure 7.1 for detailed information on what is included in the final planning notebook.

5. *Who gets copies of exhibit planning, design, production and installation documents?*

The park gets one copy of all exhibit-related documents, including planning, design, production, installation, and maintenance documents. Another set is filed with HFC, Department of Exhibits.

For contracts not coordinated by HFC, always require one set of all documents be deposited at HFC.

H. Exhibit Conservation

The exhibit environment can present the greatest threat to the preservation of an object, specimen, or archival material. Even in well-designed exhibits where light, temperature, and relative humidity are adequately controlled, an item on exhibit is subjected to more stress than in storage. Many exhibits, especially those installed prior to current preservation standards and the establishment of an object rotation schedule, don't meet acceptable standards. Sensitive objects that are exhibited for long periods of time will be damaged. Bear this in mind when you consider putting the best examples from your collection on long-term exhibit. You should develop a preservation strategy in consultation with a conservator that includes rotation and upgrades for existing and new exhibits.

Refer to Chapter 1, Section G, Preservation and Protection Issues, and consult with a conservator when making your selection for an exhibit or when you develop a rotation schedule for objects already on exhibit. Follow the steps outlined below to create optimum conditions for objects that are going on exhibit:

Make sure that conservation concerns are addressed early in the planning. Museum staff should stay involved throughout the entire process. Correct existing or inherited exhibit problems. Establish a rotation schedule for older exhibits.

1. *What is the role of the exhibit conservation specialist?*

Exhibit conservation has developed into a specialized field within the conservation profession. The exhibit conservator focuses on how exhibit techniques and environments affect the preservation of collections. The exhibit conservator develops conservation criteria, provides technical assistance to exhibit planners and designers, reviews conservation-related decisions, and assesses prototypes and exhibit work after installation. Include an exhibit conservator in all phases of exhibit development, from the earliest stages of planning and design, and throughout the fabrication and installation processes. Work with a conservator to make sure that conservation problems are avoided. Consult with the regional/SO curator and HFC conservation staff to help you find an exhibit conservator. Refer to the information in this section and Figure 7.4, Exhibit Conservation Checklist, for additional information on exhibit guidelines.

2. *Should a conservator be involved in selecting objects for exhibit?*

Yes, whenever and as early in the planning process as possible. The decision to exhibit an object is guided, in part on its condition, susceptibility to damage, and the exhibit environment. A conservator can help you decide which objects are suitable for exhibit, determine what conservation is needed, and advise on case design and lighting. Objects may need some cleaning, stabilization or repair before they can be safely and appropriately exhibited. Some objects may be too fragile to be exhibited without extensive treatments, complex design safeguards, or a rotation program. These issues need to be addressed early in the process to ensure that enough time and funds are available to come up with responsible solutions. You may decide not to use an object in an exhibit after considering preservation and treatment concerns.

3. *What exhibit conservation guidelines do I follow?*

Use *Exhibit Conservation Guidelines: Incorporating Conservation into Exhibit, Planning, Design and Fabrication* to help you plan an exhibit incorporating preservation principles. The document is available on CD-ROM from HFC, Department of Conservation. By following the *Guidelines* you will ensure that conservation issues are addressed throughout all phases of exhibit planning, development, design, production, and installation. The steps discussed in this section are based on the *Guidelines*. To obtain further details on the specifics of materials, techniques, and equipment, refer to the guidelines, and work with conservators and designers knowledgeable in exhibit conservation practices. Refer to Figure 7.4 and to <http://www.nps.gov/hfc/support/hfc-support.htm> on the Internet.

You can also refer to *MH-I*, Chapter 3: Preservation: Getting Started; Chapter 4: Museum Collections Environment; Chapter 5: Biological Infestation; Chapter 8: Museum Object Conservation Treatment; Chapter 9: Museum Collections Security and Fire Protection; and Chapter 10: Museum Collections: Emergency Planning. The

4. *What facility issues do I need to consider?*

Conserve O Gram series also contains useful exhibit conservation information.

In addition to exhibit cases, make sure that the spaces that house the exhibit cases also are conducive to object preservation and security. Make sure that the exhibit space, whether new or rehabilitated:

- is large enough to accommodate all exhibit cases and furniture
- allows for visitor flow
- meets all system power requirements
- has adequate mechanical systems in place
- meets Americans with Disability Act (ADA) Accessibility guidelines (refer to DO #16A: Reasonable Accommodation for Applicants and Employees with Disabilities, and DO #42: Accessibility for Visitors with Disabilities in National Park Service Programs, Facilities, and Services, on this topic
- meets NPS and museum security requirements (refer to *MH-I*, Chapter 9: Security and Fire Protection)

The NPS *Checklist for Preservation and Protection of Museum Collections* (see *MH-I*, Appendix F) provides detailed information on the standards that NPS museum storage and exhibit facilities need to meet. The *Revised Standard Facility Report* developed by the Registrars' Committee of the American Association of Museums also provides useful information on what your facility needs with regard to exhibits, security, handling, and environmental controls. (See *MH-II*, Chapter 5: Outgoing Loans.) It is a self-assessment tool much like the *NPS Checklist*. Facilities reports are generally used by lenders and insurance personnel to determine if an institution has the ability to safely borrow, insure, ship, handle, secure and install objects requested for loan. If you borrow objects from another institution for an exhibit you may have to complete this report.

5. *How do I plan for conservation treatment of exhibit items?*

You'll need to identify, together with a conservator, what conservation or stabilization treatments are needed for the objects that have been selected for exhibit. Generally funding for conservation for exhibit objects comes out of the exhibit budget. However, irrespective of the source, you need to make sure that conservation is included and funded in the budget.

The park, as the initiator or "owner" of the exhibit determines whether an NPS or a contract conservator will do conservation or treatment of objects slated for exhibit. The HFC, Department of Conservation, can provide a range of conservation services to the park. Their involvement ranges from consultation and advice, examination, analysis, documentation, stabilization, and treatment to extend the life of an object, to managing a conservation contract for the park. HFC is actively involved in exhibit development, and can make recommendations about the exhibit environment and the

fabrication of exhibit mounts. The park can enter into a project agreement with HFC. The agreement outlines the role that HFC or a contract conservator will have in conservation and treatment of objects.

6. *How long should objects be on exhibit?*

Always consider the object condition, duration of the exhibit, exhibit case lighting and relative humidity, case conditions, and the inherent value of the object when you determine how long to leave the object on exhibit. Even if you're using conservation-safe exhibit cases and maintaining an appropriate environment, most organic items and light sensitive materials such as feathers, watercolors, original historic photographs or blueprints should not be exhibited for more than several months at a time. It is advisable to exhibit reproductions of particularly sensitive items such as historic photographs or blueprints. Consult with a conservator when you determine how long an object should be exhibited.

Plan for frequent rotation of objects when you develop a long-term exhibit, or when you use fragile or sensitive materials. Don't place an object on long-term exhibit, regardless of how structurally stable it appears. Always use low intensity lighting.

You can minimize damage caused by long-term exposure to light and other variables by rotating objects, or substituting one object for another similar object. Some museums remove sensitive materials from display during periods of low visitation. Work with a conservator to identify those objects that need special care. You should budget for, and prioritize other alternatives, such as replicas and copies.

I. Preserving and Protecting Objects in the Exhibit Process

1. *How do I address temperature and humidity control in an existing exhibit space?*

After installation, monitor the exhibit space for one year to identify any environmental problems, then make modifications, and continue monitoring on an ongoing basis. Make additional modifications, as needed. You should obtain baseline information about the temperature and relative humidity (refer to *MH-I*, Chapter 4: Museum Collections Environment, for detailed information) before making any modifications. You can address temperature and humidity needs by taking the steps noted below.

Control the environment within the exhibit space and inside cases:

- Install small hygrothermographs or hygrometers in cases to evaluate the environment.
- Provide additional control for sensitive objects.
- Provide a well-sealed case that will support humidity control:

- minimize the air exchange between the case and the room
- use moisture impermeable construction materials
- create a microclimate to produce a stable environment for humidity-sensitive materials
- Ensure adequate air circulation within the case.
- Provide separate access to the environmental maintenance chamber:
 - make access panels as small as practicable and seal tightly with gasket materials
 - provide large cases with several access points
- Include active and passive humidity-control in exhibit cases:
 - establish whether the goal is stabilization or control
 - select an appropriate method to stabilize or control relative humidity
 - include an appropriate and sufficient moisture-absorbent medium for passive control
 - calculate the type and quantity of silica gel or cellulosic materials to be used (refer to *Conserve O Gram* 1/8, Using Silica Gel in Microenvironments and *Conserve O Gram* 2/15, Cobalt Indicating Silica Gel Health and Safety Update)
 - provide safeguards for mechanical systems
 - locate equipment in a maintenance area that does not transfer heat or vibration to the objects
 - provide a constant power supply (including emergency generators)
 - use a monitoring alarm to alert staff to equipment malfunction
 - install an adequate water supply and drain lines
- Test the case before enclosing objects to make sure humidity specifications are met and:
 - monitor the interior relative humidity for the duration of the exhibit
 - install small hygrothermographs or hygrometers in cases to

evaluate the environment

Exhibit Conservation Guidelines will give you practical ways to carry out all the procedures and points noted above.

2. *How do I address particulate contamination in an exhibit space?*

To control particulate contamination:

- Enclose sensitive objects:
 - incorporate air filters into ventilated case designs
 - seal exhibit enclosures to prevent particulate entry
- Use frequently changed ‘walk-off’ mats at the building entrance and locate exhibit spaces for sensitive items away from the entrance to minimize particulate contamination.
- Use high-efficiency filters in environmental systems for rooms housing exhibits.
- Change filters regularly.
- Use localized filtration equipment.

Refer to *MH-I*, Chapter 4: Collections Environment, for detailed information.

3. *How do I deal with chemical pollutants in an exhibit space?*

To deal with chemical pollutants, you should:

- use stable construction materials
- air the exhibit space and cases before installing objects (determine how much time is needed in consultation with a conservator)
- design the exhibit layout to minimize the objects’ exposure to pollutants
- incorporate chemical filters in the environmental systems
- monitor pollutants

Refer to *MH-I*, Chapter 4: Collections Environment, for detailed information.

4. *How do I balance exhibit lighting needs with preservation requirements?*

Develop a case lighting plan and identify lighting levels and appropriate lighting equipment with the best suited light source, fixtures, lamps, light modifying and heat reducing equipment. To balance exhibit lighting needs with preservation requirements, you should:

- Develop a lighting plan in accordance with established

conservation criteria (refer to *MH-I*, Chapter 4: Collections Environment, for detailed information) including acceptable lighting levels for objects, in particular, sensitive objects.

- Use fiber-optic lighting systems with remote lamps where possible.
- Make sure lighting ballasts don't overheat cases.
- Limit total light exposure and intensity:
 - turn off lights during nonpublic hours to limit exposure
 - provide separate lighting for security checks, exhibit cleaning, and routine maintenance
 - use occupancy sensors and pressure-sensitive mats to turn lighting on and off during visitation hours to provide a low-tech and low-energy alternative to constant lighting
- Reduce the levels of ultraviolet radiation to 10 microwatts per lumen or below.
- Control infrared radiation.
- Locate objects away from light sources:
 - at least 24 inches from filtered fluorescent lights
 - at least 36 inches from incandescent or tungsten halogen lights
- Exclude sunlight:
 - limit total light exposure during installation, exhibit, and other routine work
 - filter daylight already present in the exhibit space for UV radiation
- Construct lighting mockups to evaluate the amount and quality of light provided by the proposed lighting plan.
 - measure final light levels
 - adjust accordingly during installation
- Isolate lights from the display chamber.
 - place all lighting fixtures outside the display area of a case
 - contain any lights that are integral to the case in a separate

compartment

- seal the lighting chamber to prevent entry of insects, heat, and dust

- Reduce heat gain and temperature cycling. *Note:* The heat gain inside the display chamber should be no more than 2° F when lights are turned on.
- Ventilate the lighting chamber to dissipate heat from fixtures and use electric fans as needed.
- Incorporate heat-reflecting and insulating materials when necessary.

5. *How do I avoid a biological infestation in an exhibit?*

Develop an Integrated Pest Management Program (IPM) for your exhibit space. In particular:

- Isolate and observe objects for signs of infestation and active mold before placing on exhibit.
- Regularly examine all objects for signs of infestation and active mold.
- Design exhibits to inhibit infestations:
 - insect proof exhibit area by screening open windows or doors
 - fill gaps in the building and case construction
 - avoid gaps where dust can collect
- Enclose objects inside well-sealed cases.
- Avoid introducing insects through props and unexamined exhibit materials:
 - don't use wool carpets and other materials that attract and harbor insects
 - avoid using organic exhibit props
 - fumigate or freeze vegetal props before bringing them into the museum
- Don't allow food and beverage consumption during exhibit production and installation or in the exhibit area after the exhibit opens, including special events. The maintenance staff must be diligent in removing all food and beverage waste from areas adjacent to the exhibit.

- Use and monitor insect traps as part of your ongoing IPM program.

Refer to *MH-I*, Chapter 5: Biological Infestation, for additional information.

6. *What should I do about physical security in an exhibit?*

You can make sure your exhibit is physically secure:

- Conduct a risk assessment in accordance with procedures outlined in *MH-I* and in consultation with the park security officer to identify the possibility of theft and vandalism.
- Provide the appropriate protection.
- Tailor the exhibit security features to the vulnerabilities of objects.
- Use tamper resistant hardware.
- Control access to the objects in exhibit cases.
- Make each object on exhibit readily removable without disturbing or moving adjacent objects.

Refer to *MH-I*, Chapter 9: Security and Fire Protection, and Appendix G: Protection of National Park Service Museum Collections, for additional information.

7. *What should I do about emergency preparedness and fire protection for an exhibit?*

Take these precautions:

- Perform a risk assessment, in accordance with procedures outlined in *MH-I*, and in consultation with the park security officer and park emergency management staff.
- Anticipate the types of damage that may occur to display objects.
- Address potential problems where possible to avoid risk.
- Develop an emergency preparedness response plan that addresses fire, flood, earthquake, theft, and other hazards for the exhibit.

Refer to *MH-I*, Chapter 9: Security and Fire Protection, and Chapter 10: Emergency Planning, for additional information on how to develop an emergency preparedness plan.

8. *How should I protect objects during production and installation?*

Production and installation can present potential threats to objects because they're being moved, there are lots of people around, cases are being constructed, and many other variables. You can protect objects if you:

- limit transport of objects into production areas

- inspect exhibit assemblages that affect objects
- complete construction before object installation
- clear exhibit area of debris and dust

J. Exhibit Case Design

1. *What do I need to know about exhibit case design and construction?*

Work with a conservator to select exhibit cases that will meet the needs of your objects and the exhibit. Choose the most appropriate and practicable cases to do the job. Work with a security expert to make sure that your cases will provide maximum protection from vandalism and theft.

Exhibit cases provide the primary protective environment for objects on exhibit. You should make sure that the issues noted below are addressed.

Exhibit case design

- Design cases as protective enclosures to create microenvironments inside the cases.
- Establish performance criteria and design the case to provide this performance.
- Build and test a prototype case to decide whether it meets design and performance objectives.
- Provide detailed case drawings and specifications to your fabricator.
- Inspect cases during fabrication to ensure compliance with specifications.
- Test assembled case in its final location to make sure that conservation criteria are met before object installation.

Case stability, security, and access

- Construct a physically stable, structurally secure case.
- Provide appropriate security features.
- Provide for legitimate and practical access.
- Incorporate doors or other practical access options in the case design.

- Make sure that park museum staff can readily enter the case without compromising security.
2. *What do I need to know about sealed and ventilated exhibit cases?*

Work with the conservator to determine if you need sealed or ventilated cases.

Sealed exhibit cases

- Determine which objects, if any, require protective microenvironments, and design cases accordingly.
- Design cases to avoid the risks from interior contaminants.
- Design well-sealed cases with tight joints and with gaskets around all removable panels and entry doors.
- Select construction materials that limit air exchange and aren't moisture-permeable.
- Minimize leaks with adequate gaskets and caulk.
- Use non-hazardous materials for all construction.

Ventilated exhibit cases

- Make sure that climate-control and pollutant-control system functions 24 hours a day.
- Design and construct well-sealed, ventilated cases in consultation with a conservator and exhibit case designer.
- Filter vents to prevent dust, insects, and chemical pollutants from being drawn into the case.
- Use positive air-pressure cases when appropriate.

3. *What do I need to know about exhibit case materials?*

You need to follow these procedures:

- Select, in consultation with a conservator, high-quality, non-hazardous (to humans and collections) materials to construct case interiors and case furniture.
- Use mechanical fasteners in the construction of exhibit furniture, avoid adhesives when possible.
- Use 100% acrylic paints with low volatile emissions for wood and metal surfaces; powder coatings can also be used for metal surfaces.
- Allow sufficient curing time in consultation with a conservator before installing objects, such as 4 weeks for newly painted cases.

- Isolate objects from painted or varnished surfaces and other objects with a mount, foil, or another acceptable barrier, such as polyethylene or polyester sheeting.
- Check fabrics for dye stability and fastness; pre-wash, dry, and remove excess dyes and finishes.
- When necessary, incorporate a pollutant absorber or scavenger such as activated charcoal and potassium permanganate to ensure a pollutant free environment.

4. *What do I need to know about exhibit mount design and fabrication?*

Select mounts carefully and make sure they are designed to meet the object's needs. If they are made from conservation (stable museum quality) safe materials, you'll be able to prevent unnecessary damage to vulnerable exhibit items.

- Design and fabricate mounts for object installation ahead of time.
- Use a qualified mounting specialist who has preservation training.
- Protect the integrity of the item:
 - create custom-padded mounts
 - don't physically alter or dismantle objects to accommodate placement or mounting in the exhibit
 - use mechanical designs to lock mounts in place
- Support the entire object.
- Provide adequate support for flexible objects:
 - for organic materials, support the structure under its entire contour
 - don't crease, bend, or fold textiles, papers, leather, and other susceptible organic objects
 - don't place heavy objects directly on top of other items
- Support all parts independently:
 - support fragile objects over as large an area as practical
 - support attached parts
- Stabilize objects from vibration and abrasion.
- Secure framed works:

- attach frames to the wall with appropriate hardware, such as “D” hooks and braided metal wire
- anchor the wall fastener firmly to the wall
- make sure the fastener can support the weight of the framed item
- ensure that the wall, ceiling, or floor is designed to accommodate additional load and that the fastener is installed at a location, and in a way to successfully transfer this load

K. Traveling and Non-NPS Initiated Exhibits

This section only covers traveling exhibits that are received by the park. Objects in traveling exhibits are treated as incoming loans. Refer to *MH-II*, Chapter 2: Accessioning, for information on generating an incoming loan. Refer to *Museum Registration Methods* by Dudley et al (1979) and *The New Museum Registration Methods* by Buck et al (1998) for detailed information on preparing a traveling exhibit.

1. *What do I need to know about traveling exhibits at the park?*

The originating organization and the receiving park share the responsibility for the traveling exhibit. Traveling exhibits are usually scheduled well in advance. All arrangements, including financial, shipping, and insurance, are negotiated in advance, to the satisfaction of both parties. The hosting (receiving) park is responsible for:

- providing an appropriate exhibit venue
- maintaining the well-being of loaned objects, including preventive conservation
- maintaining exhibit furniture
- providing stable relative humidity and temperature controls
- ensuring security for the duration of the exhibit
- providing an exhibit staging and de-installation area
- tracking objects from receipt to the de-installation
- designing and installing exhibit, if needed
- offering public programming, if appropriate

Well before the exhibit is received, the park should have the following documents:

- exhibit contract (see Figures 7.1 and 7.2.)
- loan agreement
- relevant checklists, including object, case, and furniture numbering systems
- packing instructions from the initiating organization
- gallery layouts
- object number and display location lists

- installation instructions, photographs, and diagrams
- shipping instructions

The park may be required to complete the AAM Facilities Report (see *MH-II*, Chapter 5: Outgoing Loans).

A well-developed traveling exhibit is accompanied by the following:

- exhibit checklist
- crate list, including crate size and weights, packing lists, and diagrams
- crate contents
- object condition reports
- list of equipment needed to receive and install the exhibit
- list of accompanying exhibit furniture, mounts, and graphics
- packing list with specific instructions for each item
- list of lender's requirements
- insurance documents, such as a certificate of insurance naming the park as an additional insured, if appropriate
- customs documents for international traveling exhibits, if appropriate
- transportation arrangements

Refer to *MH-II*, Chapter 4, Section VII, Purchasing Insurance for Borrowed Objects. Park staff may be expected to pack and unpack the traveling exhibit. Always follow all unpacking and installation instructions. Carefully record object condition when you unpack, install, and de-install objects. You should also do regular checks while the objects are on exhibit. Report any damage immediately to the originating organization.

2. *What should I do if the park is solicited to provide an exhibit venue?*

The park may be approached by an individual or organization to host an exhibit. All requests must be made in writing and approved by the superintendent. The requestor should also provide information on the following:

- exhibit theme
- number and quality of items to be exhibited

- display system requirements
- space requirements
- lighting requirements
- installation requirements
- security
- storage
- associated costs
- publicity
- associated public programs
- insurance
- catalogs or brochures

The superintendent determines if the exhibit is appropriate for the park. If the exhibit is approved, a loan agreement is completed and signed.

3. *What do I need to know about photography, reproduction, and publicity for the exhibit?*

Make sure that the exhibit contract or loan agreement includes written permission for the park to photograph, telecast, or reproduce the items on exhibit for education, catalog, public programming, and publicity purposes. The contract should also outline who is responsible for doing exhibit publicity and press releases, frequency of releases, and public programming details. Include a statement in the exhibit contract or the loan agreement that photography of borrowed items on exhibit by visitors is governed by procedures outlined in DO #53 and Reference Manual #53: Special Park Uses, Chapter 6, Special Uses of Collections, and legal requirements outlined in Chapter 2: Legal Issues.

L. Exhibit Funding and Outreach

1. *How do I get support for my exhibit concept?*

To get support for an exhibit project, you'll need to give the potential backer, such as a granting agency or corporate sponsor, a clear idea of the exhibit and exhibit theme. You should also prepare a justification as to why this would be an excellent project to support. Include a comprehensive summary and overview of the proposed exhibit. An attractive presentation package should include:

- narrative description of the exhibit themes and sub-themes

- floor plan
- diagram indicating orientation of exhibit cases
- broad description of object types
- general description of exhibit media and elements, such as audiovisual or interactive media
- scale model, if possible
- schedule
- budget

The presentation package can be used for fund raising for your exhibit. The HFC, Department of Exhibits, can assist you in preparing materials, providing cost estimates, designing a brochure, and completing a business plan to include in the package. You need to work with park management and the region to raise funds, or to submit the concept to the Development Advisory Board or the National Park Foundation to raise funds. Many organizations fund museum exhibits. Refer to the Foundation Center Website at <http://www.foundationcenter.org/> for information on funding sources for federal institutions.

2. *What are some funding sources?*

Some of NPS funding sources include:

- HFC exhibit repair/rehabilitation funds
- Recreation Fee Program funds
- cyclic maintenance funds (may provide funding for cases or for ongoing maintenance)

Some non-NPS funding sources include:

- park cooperating associations
- foundation grants
- individual and corporate donations
- partnerships with other organizations and federal agencies

Consult with your regional curator for information on how to apply to various sources for funding.

3. *How do I estimate exhibit costs?*

Costs are based on square footage of the exhibit space and complexity of the exhibit. Exhibits with lots of audio-visual needs, dioramas, and publications tend to be more expensive than traditional case

exhibits. Consult with the regional/SO curator or HFC to develop cost estimates. HFC is developing a cost-estimating guide that will be made available to parks. You can use these estimates in a fund-raising package.

4. *Can I develop a traveling exhibit?*

Yes, you can. However, NPS museum exhibits aren't usually funded to support traveling exhibits. If the park wants to do a traveling exhibit, the park will need to seek funding to support all phases of exhibit development. This includes transportation, packing and shipping, and insurance. See Section L.1 for additional information on funding. Remember that designing an exhibit to withstand the rigors of travel is often more expensive than designing a permanent or temporary exhibit that doesn't travel. You'll need to make this decision up-front, so that you can plan the budget accordingly.

5. *Should I develop an exhibit Web feature?*

Yes, by all means. The Web allows you to reach a very large audience outside the park! A finished "real" exhibit provides you a perfect opportunity to develop a Web exhibit with a relatively small investment of time and effort. Much of the research on the exhibit has already been done. You have existing label copy, which usually takes a huge amount of time to research and write. Objects and images have already been researched and identified. The major expenditure will be in getting high quality photographs of selected items on exhibit. Have the photographs and drawings scanned. Work with a Web designer to develop an exhibit feature. For detailed information on developing Web features, refer to *MH-III*, Chapter 3: Publications. Be sure you have obtained all the necessary intellectual rights to use images on the Web in accordance with Chapter 1: Evaluating and Documenting Museum Collections Use, Chapter 2: Legal Issues, and Chapter 3: Publications.

6. *Should I produce an exhibit catalog?*

Yes, if it's feasible. A paper-based catalog of your exhibit makes an important contribution to the park's resource interpretation program. An exhibit catalog is a very useful interpretive medium. It long outlives the actual and Web exhibits. Visitors who see the exhibit and come away with a catalog extend their park learning experience long after they leave the park. The exhibit catalog provides an ideal opportunity to share your collections with the general public, students of all ages, museum professionals, and colleagues. An exhibit catalog places your collections into local, regional, and national library catalogs for all to see in a way that the actual exhibit cannot. If you are on a tight budget, a low-key or park-generated catalog records the exhibit and promotes the park museum collection. Refer to Chapter 3: Publications, on how to produce an exhibit catalog.

7. *Should I train staff and volunteers to interpret a new or upgraded exhibit?*

Yes. Interpretation and education are primary NPS and museum goals. The training you provide will enable staff to develop interesting and informative talks; tours, and materials for exhibit visitors. An informed interpreter can facilitate an enjoyable and creative learning experience for students of all ages. Provide in-depth and well-organized information about the exhibit to staff and volunteers who will be interpreting the exhibit

Each park is responsible for developing its own interpretation

program. You can make an important contribution to the park interpretation program by:

- working with the park interpreter to develop an exhibit interpretation training program
- providing in-depth talks on the exhibit
- preparing a slide presentation and handouts that staff or the volunteer interpreter or docent can use for in-house talks
- designing classes or lecture series for the local community
- organizing a demonstration or film festival around the exhibit
- preparing a frequently-asked-questions handout for docents/interpreters to carry during a tour
- working with the cooperating association to make sure that the shop includes related materials, such as books, postcards, and other appropriate items for sale

Remember that interpretation is “an educational activity which aims to reveal meanings and relationships through the use of original objects by first hand experience, and by illustrative media, rather than simply to communicate factual information” (Freeman Tilden).

8. *Should I develop school programs and kits for the exhibits?*

Yes. Work closely with the interpreters to develop a school program, teaching kit, and lesson plans about the exhibit. You, as the person responsible for the park museum and archival collections, have an important contribution to make to the park interpretive and educational program. You have a wealth of information about the life ways, people, species, ecosystems, places, and events represented in your park’s collections. A school program or kit provides an ideal opportunity for you to directly communicate the park’s mission and the exhibit theme to local schools. The package will allow you to extend the life, range, and usefulness of the exhibit. If you participate in the development of a school program or kit, you can make sure that the park collections are integrated into the package.

Work with the local schools to develop appropriate educational materials that include park museum collections. You can also hire contractors to develop curriculum-based packages. There are extensive teaching tools on the Web. Refer to the NPS Museum Management Program Website at <<http://www.cr.nps.gov/museum>> and *Teaching with Historic Places* at <<http://www.cr.nps.gov/toolsfor.htm>>. The Department of Education site, Federal Resources for Educational Excellence <<http://www.ed.gov/free/>> lists hundreds of education resources that are supported by agencies across the U.S. federal government.

9. *How do I promote the exhibit within the*

To increase visitation and ensure that you meet the park’s education and interpretation mission:

community, across the state, or across the nation?

- Promote the exhibit as widely as possible. Community representation on the exhibit team goes a long way to get out “word of mouth” publicity for your exhibit.
- Develop an exhibit fact sheet for NPS interpretation staff and for wider distribution.
- Work with the park public relations officer and community representatives for ideas to advertise the exhibit.
- Advertise in local newspapers and on buses.
- Do radio spots and give interviews to the press.
- Develop public programs, lectures, and events.
- Arrange for craft demonstrations and performances.
- Write and distribute effective press releases.
- Develop an exhibit brochure and make it available at the visitor center and in the exhibit.
- Submit press releases about the exhibit to newspapers, magazines, and tourist brochures.
- Partner with other historical societies, parks, and museums to do a joint marketing effort, particularly if you’re able to produce thematically linked exhibits.
- Work with the state tourism bureau to make sure your park’s exhibit is well publicized.
- Place exhibit announcements in specialty magazines and papers to reach specialized audiences.
- Make sure that an exhibit description and hours of viewing are placed on your park’s Website.
- Establish a link between your Web exhibit and the Museum Management Program Website.

M. Documenting Collections on Exhibit

It is particularly important to document all aspects of the exhibit, from the early stages of planning to the exhibit installation and post-installation evaluation. Use long-lived media for documentation. Keep track of all the work that is done and which items are selected for exhibit. Capture the research done on the objects and record

condition and other pertinent information. Good documentation allows you to get your exhibit-related work done in a timely fashion. It also means that you're building a history of use for each object. Careful documentation means that issues and questions can be readily answered while you're working on the exhibit, and once the exhibit is up.

1. *How do I document collections going on exhibit?*

You need to document all phases of the exhibit and the objects that are installed. Use the Automated National Catalog System (ANCS+) to generate the forms noted below. Be sure to update entries in ANCS+ once the exhibit has been installed. Refer to the ANCS+ *User Manual*, Chapter 4, Associated Module sections on Exhibits, Loans In, and Conservation, for detailed information on how to enter data into ANCS+.

The documentation of collections on exhibit includes the following (refer to Figure 7.3, Park Exhibit Checklist):

- **Accessioning and cataloging:** All objects, specimens, and archival items must be accessioned and cataloged in accordance with the *MH-II*, Museum Records, and entered into ANCS+. Take detailed measurements of the object, where possible, and include on the catalog card. Make sure that every part of the object is numbered before it goes up on exhibit. Enter the exhibit title and the exhibit duration in the exhibit module of the ANCS+ catalog record.
- **Exhibit folder (or binder):** Generate an exhibit folder or binder to hold all related documentation, such as the exhibit and photo inventories, so that you can find all exhibit information readily. Keep related memos, general notes, budget, shipping and packing information, and other related information in the exhibit folder. Reference the file from the catalog or accession folders of each item as needed. Exhibit files are usually kept chronologically, by exhibit date. The information you file may prove to be very useful in the future.
- **Exhibit inventory:** Develop a list of all items on exhibit. The list should note the specific exhibit room and case location, catalog numbers, and object dimensions and weight. Use the exhibit inventory together with the photo inventory described below. Complete the exhibit module in ANCS+ and update the object status and location in ANCS+. Develop a case numbering system and number the cases consistently in an unobtrusive but readable place. Place a number diagram of the cases in the exhibit folder. A floor plan with object location facilitates security and condition checks.
- **Caption sheet and credit line format:** Develop a standard caption and credit format for all items that are going on exhibit. Refer to Chapter 3, Section E.18, What do I need to know about writing captions?

- **Object photography:** You should have a dated record photograph of every object, specimen, and archival item that is in the park exhibit. Refer to *MH-II*, Appendix L: Photography, for technical guidance on taking photographs of objects before they go up on exhibit. Record photographs should provide adequate visual information on the object for security and condition purposes.

Once the exhibit is installed, take or arrange for a professional photographer to take photographs of all cases and objects as installed. Use one set of case installation shots as a photo-identification (photo-ID) for all objects on exhibit. Record individual catalog numbers on every object in the photo-ID. The photo-ID makes for ready identification for inventory and security purposes. Add a copy of the photo-ID to the exhibit folder and maintenance manual.

- **Object condition report:** Complete an Object Condition Report (Form 10-637) to record all structural and surface conditions such as tears, losses, cracks, chips, holes, abrasion, tape residues, mold, buckling, discoloration, and other conditions that are present when the object goes on exhibit. Record this baseline data before the object is treated or goes on exhibit. This will allow you to easily track what changes the object is undergoing while on exhibit, and whether you need to make adjustments, or remove it from the exhibit. Keep a copy of the object condition report in the accession or catalog folder, and in the exhibit folder or maintenance manual. Enter treatment and condition data on the ANCS+ catalog record and in the ANCS+ conservation module.

Some objects may need stabilization before going on exhibit. Such work may include cleaning or re-assembly of broken parts.

For additional information on conservation, refer to Section E, Exhibit Conservation, *MH-I*, Chapter 8: Conservation Treatment, and to the HFC conservation Website at <http://www.nps.gov/hfc/support/hfc>.

All conservation treatments must be documented in writing. An adequate treatment record should be accompanied by detailed photographs. Refer to *MH-I*, Chapter 8, Section C, Documentation of Object Conservation Treatment, for detailed information on the different types of documents that are completed at different stages of conservation work.

- **Incoming loan agreements:** Wherever possible, include the park's collections in the exhibit. A park exhibit offers the ideal opportunity to share the collections with the public, and to achieve the park's resource interpretation and educational mission. Park collections are park resources in their own right, and should be used to interpret the park mission and goals.

However, it may be necessary to borrow materials for exhibit. Refer to *MH-II*, Chapter 2: Accessioning, for information on negotiating an incoming loan agreement. Keep all insurance documents with the appropriate catalog files. See Section O.2 below.

The conservator usually prepares the following:

- **Object examination report**
- **Object treatment proposal:** The park approves all treatment before any work is begun.
- **Object treatment report (OTR):** You should also request a copy of an object preparation report, if one was prepared. It records information on what work was done to prepare the object for exhibit.
- **Maintenance manual:** Refer to Section O.2 for information on what is in the exhibit maintenance manual

2. *What do I need to know about acquiring rights to images?*

Exhibits often include photographs, drawings, and other artwork. Whether the images or artwork are part of your collection or from an outside source, make sure that you have the right to use the work in an exhibit. There are several laws, in particular, the copyright law, that affect the use of collections.

Copyrights are a bundle of rights given to creators, including economic rights to:

- publicly display (or exhibit) works
- reproduce work
- distribute copies by sale or transfer of ownership
- publicly perform work
- prepare derivative works

The Copyright Act of 1976 (17 USC 101-810 et seq. [1988 & Supp v. 1993]) covers archival and manuscript collections, including manuscripts, pictorial, print, graphic, and photographic works, electronic records, films, videotapes, and related materials and other original works, including fine and decorative art works, and architectural works, from the moment of creation.

Refer to Chapter 2: Legal Issues, for detailed information on copyright.

Check the accession and loan folders to verify that the park owns the rights to the artwork or images and can exhibit the material. It is

important when accessioning an object, to have the donor convey all rights to the NPS. If the owner chooses to retain the copyright, make sure you add a clause in the special conditions box stating that the copyright holder gives the NPS permission in perpetuity to exhibit the donated material. In the case of an incoming loan, add a clause stating that the lender gives the NPS permission to exhibit the photographs, drawings, and other artwork and include images of the borrowed material in paper and Web publications.

If the park does not own the artwork or images, make sure that you have written permission from the holder of the rights to use the artwork or images in the exhibit, paper and Web publication.

File all permissions in the accession or catalog folder. Be sure to record the institution's tracking number(s) and credit and caption formats as required by a lender. Refer to Chapter 3, Section C.18, on how to write a caption and give an appropriate credit. Make sure you label all images, including those that were not used in the exhibit, with the correct credits, caption, and identification numbers on exhibit and in the exhibit folder. It will prevent confusion if you wish to use those images for other exhibits or publications at a later date. File all the written permissions in an exhibit file.

- | | |
|---|---|
| 3. <i>Should I insure borrowed objects?</i> | Yes, if the lender requires insurance. Complete insurance arrangements in accordance with the procedures outlined in <i>MH-II</i> , Chapter 4: Section VII, Purchasing Insurance for Borrowed Objects. |
| 4. <i>How should I document the artwork and maps that are prepared for the exhibit?</i> | Make copies of the artwork and maps. Note the identifying numbers and source on each copy and file in the exhibit folder. |
| 5. <i>How do I handle reproduction of an object or image?</i> | If you are unable to obtain an original object for the exhibit, either from the park collections or by borrowing from another institution, you may decide to reproduce the object. Similarly, if the original archival item is too fragile to exhibit, you should have a reproduction made. Refer to Chapter 4: Two-dimensional Reproductions, and Chapter 5: Three-dimensional Reproductions, for detailed information and guidance on handling reproductions. |

N. Evaluating Exhibits

- | | |
|----------------------------------|--|
| 1. <i>Why evaluate exhibits?</i> | All exhibits should be evaluated because they absorb considerable park resources, such as funding and staff time, particularly during development and installation. Therefore, it makes good sense to understand what is needed to get the park's exhibit message across, to see what will work, how learning will take place, and how well the "product" or exhibit is received. Well-run businesses understand their customers. They know how to attract visitors, conduct market research, and test the product. They also know how to bring visitors back by refining the "product" once it has reached the market. An |
|----------------------------------|--|

exhibit that reflects so directly on the park, staff, resources, and its commitment, deserves no less. Evaluations of exhibits enable park staff to better serve the public.

2. *What kinds of exhibit evaluations are there?*

Evaluation should be done before, during, and after the exhibit is completed. The project coordinator and the exhibit team evaluate the exhibit informally throughout all phases of its development. It is essential to have exhibit content reviewed by subject matter experts. Most exhibit designers informally evaluate their work to make sure that the goals of the exhibit and specifications are met. Get substantive evaluation early on in the project. This ensures that all issues can be addressed in a reasonable and timely way. Evaluations done late in the process may mean additional costs or that the changes won't be made at all. The project coordinator should also write an

evaluation of the exhibit once it is installed, and make sure that appropriate modifications are made. It is important to evaluate early and often. Evaluations contribute to effective exhibits.

The park can also obtain formal evaluations of exhibits. These include activities such as surveying, interviewing, obtaining feedback, and observing visitor behaviors and timing movements through the exhibit. Professional exhibit evaluators do exhibit evaluations. Contact HFC exhibits or Museum Management Program staff to assist in locating professional exhibit evaluators. Different types of formal and informal evaluation yield useful information. They include the following:

- **Front-end evaluation:** The front-end evaluation, as its name suggests, is done very early in the planning of an exhibit. It can be formal or informal. Front-end evaluation occurs before any exhibit development. Exhibit themes and potential exhibit contents are closely examined. Subject matter experts critically review and evaluate draft exhibit documentation and copy. Visitor surveys and an analysis of the audience's pre-knowledge and interest in the topic are evaluated by exhibit evaluators, including HFC or contract staff. This information is obtained before the exhibit is developed. The front-end evaluation seeks to identify and eliminate errors before they arise.
- **Formative evaluation:** Ongoing or formative evaluation occurs during the process of developing the exhibit. Formative evaluation includes surveys and focus groups. Information about visitor behaviors is obtained by creating and testing mock-ups and elements of the exhibit. This allows staff to modify the exhibit to ensure a more successful exhibit. It assesses what measures to use to determine what learning will take place and what visitors understand. Lighting, signage, and visitor orientation are also examined and adjusted as necessary during this stage of evaluation.

- **Summative evaluation:** The final or summative evaluation takes place once the exhibit has been installed. Of course, it is important to anticipate and identify problems before the exhibit is installed. Once the exhibit is installed, it can be expensive and time consuming to correct. The summative evaluation can, however, provide very useful information for future exhibit development.
- **Remedial evaluation:** Remedial evaluation is undertaken to make modifications and adjustments to the exhibit once it has been up for a while. Direct observation of visitors and how they react to the exhibit is revealing and useful. Traffic flow and entrance and exit behaviors are observed. Additional information is obtained from formal interviews, informal discussions, and questionnaires. A combination of these methods will give you a better understanding of visitors, what kind of learning occurs, exhibit effectiveness, and how to make adjustments.

The project coordinator and appropriate park staff should monitor evaluations closely. This will ensure that the needed modifications are made with minimal impact on the exhibit at different stages of development. The park works with HFC or the contracting officer's technical representative (COTR) to make sure that problems are corrected in a timely way.

3. *When do I conduct the final exhibit review?*
Do a very thorough walk-through of the exhibit as it nears completion, and verify that all the contract specifications have been met. Do another walk-through once the installation has been completed. Make notes and develop a list of problems. You should also do another walk-through with members of the park exhibit team, in particular, the maintenance staff. You and other park staff will be responsible for the exhibit once the design firm leaves. Therefore, it is very important for you to make sure that all the specifications have been met. Give a copy of the list to the contractors. Don't sign off on the work until the problems on the list have been addressed to your satisfaction.
4. *How do I evaluate the exhibit's effectiveness for visitors?*
It is extremely useful to discover information about the park museum visitor. Work with interpretation staff to obtain pertinent visitor information, and to visitor responses to the exhibit. Museum visitors have different life experiences, learning styles, and demographic variables such as socio-economic background, gender, and motivation. An exhibit evaluation combined with knowledge of visitor demographics can help you plan related public programs. It is extremely helpful to solicit responses throughout the exhibit development and make necessary adjustments to the exhibit.
5. *How do I correct minor factual errors*
If you find a mistake or a minor factual error soon after the exhibit is installed, immediately contact the group that designed and installed the exhibit. If the HFC Department of Exhibits staff did the exhibit

or coordinated the contract, immediately notify HFC by phone, and follow with a memo. HFC works with the contracting officer's technical representative (COTR) to determine when the error occurred. The COTR then contacts the contractor to have the problem corrected and new signage installed in the exhibit. If new information or a new interpretation needs to be included in the exhibit, contact HFC Department of Exhibits staff. The park will need to negotiate with HFC to have minor rehabilitation of the exhibit completed. Follow the same procedure with a non-NPS contractor.

6. *How do I track visitation to the exhibit?*

Work with park interpretive staff to develop a strategy to track visitation numbers. You should also consider asking interpretive or visitor center staff to monitor and record visitor impressions. This information may be very useful for you to make any adjustments or refinements to the exhibit, and to develop some "Frequently Asked Questions" worksheets about the exhibit that visitors may find very helpful.

O. Maintaining Exhibits

1. *Who maintains exhibits?*

The park assumes responsibility for maintaining the exhibit once the installation is complete. **Note:** Never underestimate the importance of routine maintenance. A well-maintained exhibit reflects well on the NPS and the park. Always keep the exhibit and exhibit space clean and in excellent shape. Broken or non-functioning multi-media give a poor impression of the park, so make sure that interactive or multi-media features are always in working order. Work with park management to establish, fund, and implement a schedule for routine maintenance of exhibits. Remember that good maintenance takes time, money, and a commitment to having the park's public face look its best.

Maintain the exhibit in accordance with the manual provided by the planning and design firm that installed the exhibit. Refer to the NPS *Standard Fabrications Specifications*, Project Closeout, Section 3.1, Maintenance Manuals. The company or contractor must provide a maintenance manual for the exhibit. The park can also enter into an agreement with a contractor to maintain a particularly complex exhibit. However, this is relatively unusual.

2. *What's included in an exhibit maintenance manual?*

An exhibit maintenance manual should include the following:

- contract information, including the following for all who worked on the exhibit:
 - name
 - address
 - telephone number
- procedures and cleaning instructions for:
 - exhibit structures
 - finishes
 - graphic panels
 - tactile models
 - screened materials
- exhibit housekeeping schedule (refer to *MH-I*, Chapter 13: Museum Housekeeping, and *ANCS+ User Manual*, Chapter 4, Section VI, Maintenance Associated Module)
- conservation criteria for monitoring objects

- brand names of recommended cleaning materials for exhibit furniture with contact information (check with a conservator to ensure these materials will not damage objects)
- list of “not-to-be-used” materials and techniques
- repair instructions, including:
 - description of specific repair techniques for different materials
 - wiring diagrams for all equipment
 - instructions for repair or replacement of audiovisual equipment
- care and handling instructions for mounted objects, including:
 - care and maintenance of artifact mounts
 - how to remove objects from mounts
 - copies of all artifact mount drawings
- product list and catalog cuts of materials used in the exhibit
- equipment warranties
- access instructions
- electrical and mechanical instructions
- color, finish, and carpet samples of materials used in the exhibit
- copy of final planning notebook and design drawing, including:
 - exhibit drawings
 - construction details
- lighting information, including duration and intensity
- conservation features

The park gets one copy of the manual. Keep the manual in a secure place in the museum. File another copy of the manual with the HFC, Department of Exhibits.

For contracts not coordinated by HFC, always require that a copy of the manual be deposited at HFC.

3. *What is a park maintenance kit?*

The contractor should provide the following items to the park in a permanent container with a lid:

- touchup kit for exhibit cases and furniture
- two sets of all keys used in the exhibit (follow key control procedures outlined in *MH-I*, Chapter 9, Section E.7, What should I do to safeguard keys?)
- specialized tools needed for access to cases
- cleaning kit

The park should keep this kit in a safe but accessible place.

4. *What ongoing maintenance activities do I need to undertake?*

Work with chiefs of maintenance and interpretation to incorporate the new or refurbished exhibit into your museum housekeeping plan. Refer to *MH-I*, Chapter 13: Museum Housekeeping, for detailed information on how to develop and implement a museum housekeeping plan. Monitoring the well being of the exhibit is a team effort. Coordinate with park staff who regularly visit and interpret the exhibit. The more pairs of eyes you have focused on the exhibit, the greater the well being of the exhibited objects. A poorly maintained exhibit reflects poorly on the park. A well-maintained exhibit gives the visitor a positive impression of the park and its staff.

You'll need to:

- implement an exhibit housekeeping plan
 - develop an exhibit cleaning schedule and document it in the ANCS+ Maintenance Associated Module
 - identify cleaning and dusting tasks
 - keep the exhibit area clean
 - dust and vacuum case interiors regularly
 - train staff to observe changes to the exhibit, objects, or mounts
 - identify and acquire supplies and equipment needed to clean and dust the exhibit
- monitor and maintain the environmental conditions
 - monitor and maintain relative humidity and pollutant control systems
 - replace lamps and aim beam as described in the manual

- check light levels once new lamps have been installed
- monitor exhibit overall
 - assign a staff member to do a weekly walk-through inspection of the exhibit
 - inspect for pests and mold
 - record your observations and exhibit gallery conditions in a log
 - check object conditions annually
 - identify when maintenance is necessary, such as repairing the dehumidifier and replacing the spotlight
 - check case security
 - check security at entrances and exits
 - notify appropriate staff to correct problems
- rotate and substitute objects periodically

Follow guidance on handling objects outlined in *MH-I*, Chapter 6: Shipping and Handling Museum Objects.

5. *How do I monitor object condition?*

Each object, specimen, or archival item that goes on exhibit should have a record photograph and a detailed Object Condition Report (Form 10-637, see *MH-II*, Chapter 5: Outgoing Loans). The individual photograph and condition report allow you to monitor the condition over time. Photograph each case with its contents (see Section M, Documenting Collections on Exhibit). When you do a walk-through, use the photo-ID (installation photograph with individual catalog numbers) as an easy visual check to make sure all objects are still there.

Closely monitor items that are installed in an exhibit. No matter how well an exhibit has been designed, the exhibit environment is more stressful than the storage environment. Extended exhibit and longer exposure to light and fluctuations in temperature and relative humidity accelerate object deterioration. The photograph and the condition report provide you with essential baseline data to monitor security and the object's condition. You should routinely walk through the exhibit to spot any major problems. A weekly walk-through is recommended. Closely evaluate each object on a regular schedule. A detailed monthly check is recommended. Record and date your observations.

6. *When do I monitor the environment?*

Work with a conservator to establish baseline data on the relative humidity and temperature in the exhibit space and within exhibit

cases. Refer to Sections H, Exhibit Conservation, and I, Preserving and Protecting Objects in the Exhibit Process. Where possible, install recording hygrothermographs or data loggers to record relative

humidity and temperature. Regularly evaluate the readings. Keep a logbook to record current outside weather conditions and exhibit visitation, both of which can affect the exhibit and case environment.

7. *How do I handle requests to photograph the exhibit or the objects?*

Refer to Section I, Documenting Collections on Exhibit; Chapter 6, Section D, Filming and Photography in Spaces Housing Museum Collections; Chapter 2: Legal Issues; and Chapter 4: Two-dimensional Reproductions, for information on how to handle requests to photograph the exhibit and objects on exhibit.

8. *How do I establish information files to answer inquiries from staff and visitors?*

Record the most commonly asked questions and your responses. Develop subject files for the most commonly requested information. Add information, research, clippings, and photographs as you find them. You should consider developing a “frequently asked questions and answers” sheet available in the exhibit area, once you’ve determined what those questions are.

9. *What do I do if I need to take the object off exhibit temporarily?*

On occasion, you may need to remove an object from an exhibit temporarily. The object might require conservation or you may be developing an exhibit and need to photograph the object. Carefully remove the object from the exhibit without disturbing other items on display. Place an Object Temporary Removal Slip, Form 10-97 in its place. Follow the procedures for completing the slip outlined in *MH-II*, Chapter 4, Section C.2, How do I document temporary location changes? The slip ensures that staff and visitors know that the gap or “hole” in the exhibit is deliberate.

P. Rehabilitating Exhibits

1. *When should I rotate objects?*

During the exhibit planning and design phase, you will have worked with the exhibit project coordinator and designer to identify substitute objects for selected items, in particular, organic and other sensitive objects. Ideally, all objects in long-term park exhibits should be rested and rotated to extend their life span. Work with a conservator to determine the rotation schedule.

2. *What should I do if an object is damaged?*

If you detect damage to an object on exhibit, correct the problem as soon as possible. If the damage occurred as a result of a mount, case, lighting, or other conservation problem, consult with a conservator and maintenance staff to find a solution. If the damage is a result of a traffic flow problem or security breach, work with park maintenance to correct the deficiency.

Remove the object until the problem has been corrected. If an older exhibit doesn’t have a rotation schedule, you need to identify alternate objects for rotation and establish and implement a rotation schedule. Work with a conservator and HFC exhibit staff or other exhibit service providers to address conservation or exhibit problems.

3. *What should I do if a label is damaged?* If you detect damage to a label, correct the problem as soon as possible. Notify HFC or the exhibit contractor and request a replacement label. Use a corrected label until you can replace the damaged label.
4. *How do I update the exhibit?* Work with HFC, Department of Exhibits, or an exhibit contractor of the park's choice to update exhibits over time. You will engage first-time and repeat visitors by keeping exhibits current. You can do that by incorporating new information or revised interpretations about people, events, or themes. You may also want to make changes as new objects come into the park collections. Dated exhibits don't reflect well on the park or its staff. It is important to keep exhibits fresh and challenging. Effective exhibits, as the public face of the park, are an integral part of achieving the park's education mission.

Q. Selected Bibliography

- Adams, Roxanna, ed. Revised Standard Facility Report. Registrars' Committee of the American Association of Museums. Professional Practice Series. 1988.
- Alexander, Edward P. *Museums in Motion. An Introduction to the History and Functions of Museums.* Nashville, Tenn.: American Association for State and Local History, 1979.
- American Association of Museums. *Museums for a New Century: A Report on the Commission for a New Century.* Washington, D.C., American Association of Museums, 1984.
- _____. *The Gauge.* A newsletter from the AAM Committee on Audience Research & Evaluation.
- _____. *Museum News* 78, no. 5. *Special Issue: Exhibition Design*, September/October, 1999.
- Barclay, R.L., ed. *Anatomy of an Exhibition: The Look of Music.* International Institute for Conservation-Canadian Group, Ottawa, 1983.
- Belcher, Michael. *Exhibitions in Museums.* Washington, D.C.: Smithsonian Institution Press, 1992.
- Desai, Philly, and Andrew Thomas. *Cultural Diversity: Attitudes of Ethnic Minorities Towards Museums and Galleries.* Museums & Galleries Commission, The Qualitative Workshop. A Unit of BMRB International Limited, London, 1998.
- Dubberly, Sara, ed. *Exhibition Planning and Management: Reprints from NAME's Recent and Recommended.* Washington, D.C.: American Association of Museums, Technical Information Service, 1992.
- Durbin, Gail. *Developing Museum Exhibitions for Lifelong Learning.* Edited on behalf of the Group for Education in Museums. London: Museums and Galleries Commission, The Stationery Office, 1996.
- Exhibit Builder* magazine. P.O. Box 4144, Woodland Hills, Calif. 91365.
- Exhibitionist.* National Association for Museum Exhibition (NAME), the Standing Professional Committee on Exhibition of the American Association of Museums.

- Falk, John. *Visitors: "Who Does, Who Doesn't, and Why."* *Museum News* 77, no. 2, March/April 1998.
- Hall, Margaret. *On Display: A Design Grammar for Museum Exhibitions*. London: Lund Humphries, 1987.
- Karp, Ivan, and Steven D. Lavine, eds. *Exhibiting Cultures. The Poetics and Politics of Museum Display*. Washington, D.C: Smithsonian Institution Press, 1991.
- Karp, Ivan, Christine Mullen Kreamer, and Steven D. Lavine. *Museums and Communities. The Politics of Public Culture*. Washington, D.C: Smithsonian Institution Press, 1992.
- McLean, Kathleen. "Museum Exhibitions and the Dynamic of Dialogue." *Daedalus*, Journal of the American Academy of Arts and Sciences 128, no. 3. Summer 1999.
- NPS Department of Exhibits, Harpers Ferry Center. *NPS Standards Planning & Design Specifications*. Harpers Ferry, W.V.: National Park Service, February 1998.
- _____. *NPS Standard Fabrication Specifications*. Harpers Ferry, W.V.: National Park Service, July 1997.
- _____, Museum Exhibit Planner, Application Software for Planning National Park Service Exhibits. Harpers Ferry, W.V.: National Park Service.
- NPS Department of Interpretive Planning, Harpers Ferry Center. *Planning for Interpretation and Visitor Experience* Harpers Ferry, W.V.: National Park Service, 1998.
- NPS HFC Online: <<http://www.nps.gov/hfc/support/hfc-support.htm>>.
- NPS Visitor Services Project. *Serving the Visitor 1998, A Report on Customers of the National Park Service*, 1999.
- Raphael, Toby. "Creating A Set of Conservation Guidelines for Exhibitions." *CRM*, Conservation Resource Management, Volume 22, No. 7, 1999.
- Screven, C.G., ed. *Visitor Studies Bibliography and Abstracts*. Fourth Edition. Chicago, Ill.: Screven & Associates, 1999.
- Serrell, Beverly. *Making Exhibit Labels: A Step-by-Step Guide*. Nashville, Tenn.: American Association for State and Local History, 1983.
- _____. "Paying Attention: The Duration and Allocation of Visitors' Time in Museum Exhibitions." *Curator* 40, no. 2, June 1997.
- _____. *"Paying Attention: Visitors and Museum Exhibitions."* Washington, D.C.: American Association of Museums, 1998.
- Smith Levine, Melissa. "Selecting and Contracting for Exhibition Services." *Exhibitionist* 13, no.2, Winter 1994.
- Thompson, John M.A., ed. *Manual of Curatorship: A Guide to Museum Practice*. The Museum Association Butterworths, 1984.
- Tilden, Freeman. *Interpreting our Heritage: Principles and Practice for Visitor Services in Parks, Museums and Historic Places*. University of North Carolina Press, 1957 (and 1967).

R. List of Figures

Figure 7.1. Sample Wording for a Park Project Agreement with Harpers Ferry Center, Department of Exhibits	7:59
Figure 7.2. Sample Fabrication and Installation Contract Wording	7:64
Figure 7.3. Park Exhibit Checklist.....	7:68
Figure 7.4. Exhibit Conservation Checklist	7:72

Sample Wording for a Park Project Agreement with Harpers Ferry Center, Department of Exhibits

Overview

This document outlines the agreement between the Park and Harpers Ferry Center, Department of Exhibits (HFC) concerning the development of the Park's exhibit project. The agreement outlines the project description and scope, exhibit team members' roles, the proposed work plan, budget, and exhibit development schedule.

Project Description

The visitor center was built in 1965. The present exhibit was produced in the early 1980s. The Park plans to upgrade the current exhibit. The exhibit upgrade includes updating and revising the interpretive story presented in the exhibit, bringing exhibit design and production values up to current museum and NPS exhibit and conservation standards, and increasing exhibit space to 540 square feet. NPS exhibit and exhibit conservation standards are described in the NPS *Museum Handbook*, Part III, Chapter 7, and at the HFC site at <<http://www.nps.gov/hfc>>. The new exhibit area will include a cultural history exhibition, an information desk and an association book sales area.

HFC will assist the Park in developing a new exhibit for the exhibit space. HFC responsibilities include developing a schematic and concept plan and design, and final planning notebook and design drawings in conjunction with the Park

Project Resource Package

The project resource package is composed of a schematic plan and design, and a concept plan and design. HFC will develop the schematic and concept plans in close coordination with the Park. HFC will develop the final planning notebook and design drawing.

The schematic plan and design includes:

- a floor plan
- a bubble diagram indicating the general orientation of exhibits
- rough titles that reflect ideas and themes
- rough placement of exhibit and exhibit cases
- a broad description of object types to be included in the exhibit
- a general discussion of exhibit media and elements, such as audiovisual or interactive media

The concept plan and design includes:

- a narrative description of the exhibit
- an exhibit floor plan showing space allocation, visitor traffic flow, thematic areas
- renderings of what the installation will look like
- rough sketches of selected exhibit elements
- draft label copy
- graphics schedule or listing of artwork, photographs and pertinent identifying information

- facsimiles or drawings of:
 - specific objects or reproductions
 - actual images
 - dioramas and other exhibit furnishing

Figure 7.1. Sample Wording for a Park Project Agreement with Harpers Ferry Center, Department of Exhibits (*Note:* The wording in this figure is based on a document developed by HFC, Department of Exhibits.)

- a list of proposed:
 - objects, specimens or archival items
 - alternate objects, specimens or archival items for exhibit rotation
 - reproductions
 - photographs of objects
- audio-visual treatments including:
 - software
 - equipment
- an exhibit model
- estimates for production of all exhibit elements
- a schedule

The planning notebook includes:

- a list of objects with:
 - catalog numbers
 - captions
 - measurements, including dimensions and weight
 - substitute items
 - object rotation schedule
- a list of graphics with:
 - identifying numbers
 - captions and credits, including source
 - cropping instructions
 - graphic facsimiles
 - graphic and text ID numbers text samples
- object photographs with catalog numbers
- sources for:
 - graphics
 - artwork
 - rights
 - reproductions
 - maps
- label copy and captions
- a floor plan showing all exhibit elements:

- elevational views of all exhibit elements
- location and titles of exhibits
- an exhibit elements drawing
- narrative descriptions of:
 - exhibit elements
 - type styles
 - colors
 - finishes
 - graphics
- sample boards with actual samples of:
 - paint laminates
 - finishes
 - carpet
 - type styles

Figure 7.1. Sample Wording for a Park Project Agreement with Harpers Ferry Center, Department of Exhibits (*Note:* The wording in this figure is based on a document developed by HFC, Department of Exhibits.)

- typographic specifications
 - lighting specifications
 - conservation specifications
 - audio-visual treatments
 - performance standards for :
 - durability
 - security
 - access
 - maintenance
 - an exhibit model that incorporates all exhibit elements
 - a budget, including fabrication estimate
 - a revised schedule
 - individual task assignments
- The design drawing includes:
- the final exhibit design and layout
 - a fully detailed exhibit drawings
 - specific case details and measurements
 - floor plans and elevations including perspective view drawings
 - the lighting plan

Project Work Plan

The HFC planner and designer will meet with the Park staff and Park resource people at ____ (location) in ____ (date) to develop the exhibit story-line, themes, and objectives, and to evaluate and identify potential exhibit graphics and display objects. HFC will prepare schematic drawings of the proposed exhibits.

Park staff will prepare an Interpretive Plan for the exhibit space which will describe the story-line, themes, proposed exhibit resources, and agreements reached on exhibit issues. The Park will prepare a scope of work for project research, and then begin work, with the advice and assistance of the HFC planner. The cooperating association will provide contract research assistance.

The HFC planning team will conduct a workshop to begin development of the exhibit concept plan and design. The Park, in conjunction with HFC, will identify and prepare the planning elements of the exhibit. The HFC designer will prepare the design elements such as floor plans, elevation drawings, and sample boards. The Park reviews and approves the concept plan and design package.

HFC staff, in conjunction with the Park, will prepare the schematic plan and design, and the final planning and notebook. HFC will prepare the final text, assemble the graphics, objects, and AV resources to be included in the exhibits. The HFC designer will prepare all design elements. After review and approval of the final exhibit package by the Park, the production phase will be initiated.

HFC will produce and install the exhibits. The HFC designer will serve as the production manager. The Park will acquire, or assist HFC in acquiring, reproducible graphics and intellectual use rights. Park exhibit team staff will be invited to participate in exhibit planning, design, and production meetings, and inspections. The Park will have approval authority over all phases of work.

Figure 7.1. Sample Wording for a Park Project Agreement with Harpers Ferry Center, Department of Exhibits (Note: The wording in this figure is based on a document developed by HFC, Department of Exhibits.)

Exhibit Project Team

The exhibit team is composed of Park and HFC staff, and other specialists as needed. Responsibilities are outlined below. The Park exhibit team will participate in all planning, design, and production meetings and inspections. The Park exhibit team will review all phases of work. The superintendent will have final authorization of the exhibit.

HFC, Department of Exhibits Team Members

Team Member	Title	Project Role
Name	Exhibit Planning Coordinator	<ul style="list-style-type: none">• Serves as Park's principal contact person at HFC during the planning and design phases of the project.• Advises Park staff on how to conduct research, write exhibit text, and prepare a production-ready planning package.
Name	Exhibit Designer and Producer	<ul style="list-style-type: none">• Prepares the design elements of the exhibit production package, based on text, graphics, and objects provided by the Park.• Serves as production manager.• Serves as Park's primary contact at HFC during the design and installation phase of the project.
Name	Conservator	<ul style="list-style-type: none">• Advises the planning team on matters related to object

		<p>conservation.</p> <ul style="list-style-type: none"> • Coordinates project support tasks performed by the HFC Department of Conservation. 																		
<p>Park Exhibit Team Members</p> <table border="1"> <thead> <tr> <th>Park Team Member</th> <th>Title</th> <th>Project Role</th> </tr> </thead> <tbody> <tr> <td>Name</td> <td>Chief Interpreter</td> <td> <ul style="list-style-type: none"> • Overall Park coordinator for the project. • Primary liaison with the superintendent. • Arranges for and participates in all major project meetings. • Reviews all project documents. • Tracks budget and schedule for the Park. </td> </tr> <tr> <td>Name</td> <td>Interpretive Specialist</td> <td> <ul style="list-style-type: none"> • Serves as primary exhibit planner on the project. • Coordinates and does project research, label writing, plan document preparation. • Coordinates production-ready graphics. • Selects display objects in conjunction with the curator. </td> </tr> <tr> <td>Name</td> <td>Curator</td> <td> <ul style="list-style-type: none"> • Assists in identifying, locating, and as needed, acquiring objects for exhibit. • Participates in planning meetings. • Reviews planning documents with special reference to conservation concerns. • Provides catalog data for inclusion in exhibit label copy. </td> </tr> <tr> <td>Name</td> <td>District Ranger</td> <td> <ul style="list-style-type: none"> • Participates in planning meetings when available. • Reviews and comments on planning concepts and documents. • Provides information on exhibit content and visitor experience issues. </td> </tr> <tr> <td>Name</td> <td>Park Ranger</td> <td> <ul style="list-style-type: none"> • Participates in planning meetings when available. • Comments on exhibit content and visitor experience issues. </td> </tr> </tbody> </table>			Park Team Member	Title	Project Role	Name	Chief Interpreter	<ul style="list-style-type: none"> • Overall Park coordinator for the project. • Primary liaison with the superintendent. • Arranges for and participates in all major project meetings. • Reviews all project documents. • Tracks budget and schedule for the Park. 	Name	Interpretive Specialist	<ul style="list-style-type: none"> • Serves as primary exhibit planner on the project. • Coordinates and does project research, label writing, plan document preparation. • Coordinates production-ready graphics. • Selects display objects in conjunction with the curator. 	Name	Curator	<ul style="list-style-type: none"> • Assists in identifying, locating, and as needed, acquiring objects for exhibit. • Participates in planning meetings. • Reviews planning documents with special reference to conservation concerns. • Provides catalog data for inclusion in exhibit label copy. 	Name	District Ranger	<ul style="list-style-type: none"> • Participates in planning meetings when available. • Reviews and comments on planning concepts and documents. • Provides information on exhibit content and visitor experience issues. 	Name	Park Ranger	<ul style="list-style-type: none"> • Participates in planning meetings when available. • Comments on exhibit content and visitor experience issues.
Park Team Member	Title	Project Role																		
Name	Chief Interpreter	<ul style="list-style-type: none"> • Overall Park coordinator for the project. • Primary liaison with the superintendent. • Arranges for and participates in all major project meetings. • Reviews all project documents. • Tracks budget and schedule for the Park. 																		
Name	Interpretive Specialist	<ul style="list-style-type: none"> • Serves as primary exhibit planner on the project. • Coordinates and does project research, label writing, plan document preparation. • Coordinates production-ready graphics. • Selects display objects in conjunction with the curator. 																		
Name	Curator	<ul style="list-style-type: none"> • Assists in identifying, locating, and as needed, acquiring objects for exhibit. • Participates in planning meetings. • Reviews planning documents with special reference to conservation concerns. • Provides catalog data for inclusion in exhibit label copy. 																		
Name	District Ranger	<ul style="list-style-type: none"> • Participates in planning meetings when available. • Reviews and comments on planning concepts and documents. • Provides information on exhibit content and visitor experience issues. 																		
Name	Park Ranger	<ul style="list-style-type: none"> • Participates in planning meetings when available. • Comments on exhibit content and visitor experience issues. 																		

Figure 7.1. Sample Wording for a Park Project Agreement with Harpers Ferry Center, Department of Exhibits (Note: The wording in this figure is based on a document developed by HFC, Department of Exhibits.)

Other Exhibit Team Members

Team Member	Title	Project Role
Name	Director, Historical Society	<ul style="list-style-type: none"> Assists in developing the exhibit story-line, acquiring graphics and objects. Serves as a resource person to the exhibit project team. Reviews exhibit documents.
Name	Assistant Professor, State College	<ul style="list-style-type: none"> Serves as a resource person to the Project Team. Assists in developing the exhibit story-line, acquiring graphics and objects. Reviews exhibit documents.
Name	Assistant Professor, State College	<ul style="list-style-type: none"> Provides input regarding the association display and sales functions in the exhibit space.

Project Schedule

The schedule below is based on the timely completion of all project tasks. It is understood that if preliminary tasks are delayed or incomplete, the entire schedule will be delayed. Exhibit development will require eighteen (18) months from funding to installation.

Phase	Event	Date
<i>Project Initiation</i>		February Year 1
<i>Project Initiation</i>	Complete Project Research	August Year 1
<i>Concept Plan</i>	Concept Plan Workshop	September Year 1
<i>Concept Plan</i>	Concept Plan Presentation	October Year 1
<i>Final Plan</i>	Begin Final Plan	November Year 1
<i>Final Plan</i>	Final Plan Presentation	January Year 2
<i>Pre-Production</i>	Approve Revised Final Plan	February Year 2
<i>Production</i>	Prepare Production Contract Package	March Year 2
<i>Production</i>	Post Award Meeting	May Year 2
<i>Production</i>	Exhibit Installation	October Year 2

Project Budget

The total project budget is \$130,000. All planning, design and production funds will come from this source. No other Park monies will be made available other than limited amounts for making any needed modifications to the building. Any such requirement will be negotiated with the Park. HFC and the Park will monitor the project budget to insure that the project stays within budget.

Fiscal Year	Budget Item	Amount
FY 1	HFC Exhibit Planning/Design	\$25,000
FY 1	Exhibit Fabrication Contract	\$75,000
FY 1	Object Conservation	\$7,000
FY 1	Audiovisual Production	\$6,000
FY 2	Audiovisual Equipment	\$3,000
FY 2	HFC Contracting Technical Support	\$6,000
FY 2	Historic Furnishings Production	\$8,000
	Total	\$130,000

Figure 7.1. Sample Wording for a Park Project Agreement with Harpers Ferry Center, Department of

Exhibits (*Note:* The wording in this figure is based on a document developed by HFC, Department of Exhibits.)

Sample Fabrication and Installation Contract Wording

1. Background

The Visitor Center is located X miles from the park entrance. The Visitor Center was built in 1965. It contains an exhibit space of XX square feet, which includes the museum exhibits, an information desk, and a book sales area. New exhibits for the Visitor Center will include an interpretation of the cultural history of the area. The park will install a new information desk and a new book sales area.

2. Purpose

The purpose of this contract is to provide fabrication and installation of museum exhibits for the Visitor Center. The exhibits will include exhibit cases, object mounting, interior case labels, graphic panels, and visitor-activated audio programs.

3. Scope of Work

The Contractor will provide all professional exhibit fabrication, and installation services, labor, facilities, materials, and travel (except as otherwise specified in this contract) to fabricate, transport, and install all exhibit elements for the Visitor Center at the Park in accordance with the attached drawings entitled "Visitor Center, Park Name." These drawings are hereby incorporated into this contract.

Work under this contract will proceed in accordance with the steps outlined below, the *National Park Service Standard Fabrication Specifications* <<http://www.nps.gov/hfc/exhibits/fabspec.pdf>> and the specifications outlined in *NPS Exhibit Conservation Guidelines: Incorporating Conservation into Exhibit, Planning, Design and Fabrication*.

The Contractor shall obtain the intellectual rights to all the copyrighted photographs and graphics and other exhibit materials used in the exhibit. The Contractor agrees to the terms outlined in the release form (see *MH-III*, Figure 3.6 and 7) that grants the Park the absolute and irrevocable right and permission, in respect of the photographs, graphics or audio or videotape materials developed for the Park exhibit, to use, reuse, publish and republish, and otherwise reproduce, modify and display the same, in whole or in part, individually or with other photographs or graphics, and with any copyrighted matter, in any and all media now or hereafter known, for illustration, promotion, art, advertising or trade, or any other purpose whatsoever.

The Contractor will provide the following:

A. Project Management

Scheduling, coordinating, overseeing, and managing work produced and installed under this contract.

- (1) Travel to Visitor Center to meet with the COTR for a post-award conference and to perform a site visit to review existing conditions prior to fabrication of the exhibits. The Contractor will be responsible for ensuring proper fit and operation of all exhibit elements;

Figure 7.2. Sample Fabrication and Installation Contract Wording (*Note:* The wording in this figure is based on a document developed by the Harpers Ferry Center, Department of Exhibits.)

<p>(2) Travel to the Visitor Center, to oversee installation of exhibits at the site by the installation team. The Contractor will provide project management of all on-site work including:</p> <ul style="list-style-type: none">(a) Coordination with park staff for delivery, unloading, and daily work operations on-site;(b) Daily quality control inspections of all work performed by installation team;(c) Coordination with park for final walk-through inspection, operational training session, and delivery of maintenance manuals;(d) Documentation of all listed deficiencies that result from final walk-through inspection. Copies will be provided to the COTR and the park. <p>B. Exhibit Drawings</p> <p>Preparation of preliminary and final exhibit drawings.</p> <ul style="list-style-type: none">(1) Detailing of all exhibit structures included in this contract, including exhibit cases, acrylic vitrines, and graphic panels. Work includes detailing locations of audiovisual equipment and other electrical or mechanical equipment, including vents for convection cooling, shelving, access doors, and power sources;(2) Color/finish samples for all structures and samples for picture frame molding as provided;(3) Catalog cuts for specialized hardware, including locks, hinges, mounting hardware, ventilation grilles, metal shelving for audiovisual equipment. <p>C. Exhibit Structures</p> <p>Fabrication of all exhibit elements including: cabinetry, panels, platforms, vitrines, or other elements that constitute the basic structural elements of the exhibits</p> <ul style="list-style-type: none">(1) Acrylic artifact vitrines as shown on the drawings, fabricated with UV-filtering acrylic, in accordance with standard specifications provided by the park. Edges of vitrines will be beveled. Vitrines will provide concealed chamber for silica gel as detailed in reviewed and approved detail drawings;(2) Glass exhibit cases as shown on the drawings in accordance with reviewed and approved detail drawings and the following:<ul style="list-style-type: none">(a) Glazing of cases will be one sheet of 1/2" UV-filtering laminated glass, mounted flush with surrounding exhibit panel surface. Glass will be captured with aluminum extrusion painted to match exhibit surface in accordance with specifications provided by the park. Glazing will be sealed with neutral curing silicone in accordance with specifications provided by the park;(b) Exhibit case structures will be in accordance with standard specifications provided by the park and with the <i>NPS Exhibit Conservation Guidelines: Incorporating Conservation into Exhibit, Planning, Design and Fabrication</i>. The park will review and approve the detailed drawings. Access to interior of exhibit cases will be as shown on drawings. A section of the graphic panels will swing open, allowing access to space behind exhibit. One side of the exhibit cases will open outward, providing access to the interior (object chamber). The top of the exhibit case chamber
--

will be UV-filtering cast acrylic sheet. *Note:* all glazing of the cases will remain fixed in place;

Figure 7.2. Sample Fabrication and Installation Contract Wording (*Note:* The wording in this figure is based on a document developed by the Harpers Ferry Center, Department of Exhibits.)

(c) Interior finishes of object chambers will be historic furnishings treatments to provide a room-like effect, such as wallpaper, floorboards, baseboards, etc. Where wallpaper is not supplied, the Contractor will finish the sides as shown on the drawings. The Contractor will be responsible for cutting and fitting all finishing treatments as required, including any additional wood finish treatments that may be required;

(d) Glass object cases are not required to include silica gel or silica gel chambers. However, the design and fabrication of these cases will prevent dust and vermin infiltration through gasketed door openings and siliconed seams.

D. Electrical and Mechanical

Purchase, fabricate, assemble, install into buildings and exhibit structures and thoroughly test electrical and mechanical devices; this includes lighting. Install audiovisual equipment into the exhibit structures, including electrical components to provide and ensure fully operational audiovisual systems for each exhibit unit.

(1) Installation, aiming, and adjustment of lighting fixtures and lamps into existing lighting track. The Contractor will install fixtures in approximate locations as shown on the drawings and make final adjustments as necessary;

(2) Provide power hookup to existing receptacles for each exhibit requiring electrical power. This includes multi-outlet power strips and other wiring as required to provide power to electrical elements in the exhibit structure, in accordance with the standard specifications and approved catalog cuts;

(3) Install audio and electronic equipment.

E. Photographs

Produce all photographic images. The contractor will obtain all necessary intellectual rights in writing, to display the images.

Durst Lambda C-prints by Eastman Kodak Company, subsurface laminated to 1/8" non-glare acrylic in accordance with standard fabrication specifications provided by the park.

F. Graphics

Produce all graphics.

(1) Durst Lambda output of all digital files on C-prints by Eastman Kodak Company, produced from the CD provided by the park;

(2) Digital color correction as required so that output is in accordance with color specifications;

(3) All prints will be seamless except where indicated in reviewed and approved samples;

(4) The following samples for review and approval:

- (a) Digital output of all graphic panels at one-quarter final size. Example: final size = 4' x 6', sample size = 2' x 3'. Inkjet output of samples is acceptable. Samples will include proposed seam lines indicated for review and approval;

Figure 7.2. Sample Fabrication and Installation Contract Wording (*Note:* The wording in this figure is based on a document developed by the Harpers Ferry Center, Department of Exhibits.)

- (b) Test samples of portions of graphic panels at final image size, the areas chosen so as to include all specified typefaces, type sizes, colors, and graphic treatments. Test samples will be strips approximately 12" wide by 48" long, and a minimum of five (5) will be required.

Note: After review of the samples, any required changes to the text will be performed by the NPS on the government-furnished digital file, which will subsequently be returned to the Contractor for production of the prints

G. Objects

Prepare object mounts for installation, including design, production, and installation.

- (1) Provide drawing of mounts for review and approval;
- (2) Furnish and install silica gel as specified on the reviewed and approved detail drawings and in accordance with Standard Fabrication Specifications, Department VII, Part 2. Cases that require silica gel are listed below.

H. Setup and Installation

Setup and install all exhibit elements.

In addition, the Contractor will:

- (1) Install all identified park objects and reproduction items;
- (2) Install audio equipment and programs;
- (3) Train park staff, during the course of a two-day workshop, to operate and maintain all exhibit elements, including cleaning, accessing interior of exhibit cases, removing and re-installing objects, operation and troubleshooting of audio programs, re-lamping lighting fixtures, and all other relevant maintenance questions as requested by the park.
- (4) The Contractor will supply the park and HFC, Department of Exhibits each with a copy of the maintenance manuals during this workshop and be prepared to answer questions about its content.

Figure 7.2. Sample Fabrication and Installation Contract Wording (*Note:* The wording in this figure is based on a document developed by the Harpers Ferry Center, Department of Exhibits.)

Park Exhibit Checklist

Activity	Action and Date
Initial Exhibit Planning	
Purpose of the exhibit	
Theme and sub-themes	
Develop schedule	
Develop budget	
Identify audience	
Identify partners	
Objects	
Review accession and catalog folders	
List potential objects for inclusion	
Ensure selected objects are cataloged, and include material and measurements	
Obtain object record photographs	
Provide detailed object condition descriptions	
Identify sensitive items	
Identify items needed on loan to complete the exhibit	
Complete loan agreements	
Obtain insurance	
Arrange for reproduction or copies of material	
Develop captions, including measurements, and credit lines	
Identify alternate items for exhibit rotation	

Figure 7.3. Park Exhibit Checklist

Documentation	
Create an exhibit folder to house documents such as:	
Exhibit inventory	
Case layout and object numbering schematic	
Case photographs	
Installation photographs	
Rights Acquisition	
Check accession or catalog folder to see if NPS has rights to images, photographs and artwork	
Verify transfer of copyright on accession [gift] form(s)	
Include statement on incoming loan agreement granting NPS right to exhibit item	
Obtain rights to use non-NPS images and illustrations for the exhibit, including a Web feature	
Obtain written permission and file in exhibit folder	
Conservation	
Determine conservation and preservation needs in consultation with a conservator	
Identify objects for rotation	
Obtain the following: Object Condition Report Object Examination Report Object Treatment Proposal Object Treatment Report	
Incorporate condition and treatment information in ANCS+	
Research	
Obtain background information	
Develop exhibit themes and sub-themes	
Develop thematic label copy	

Figure 7.3. Park Exhibit Checklist

Identify objects for exhibit	
Incorporate individual object captions	
Review text	
Planning and Design	
Prepare initial development and design plan	
Review plan and incorporate edits	
Schematic plan and design	
Review plan and ensure conservation needs are addressed. Incorporate edit	
Concept plan and design	
Review plan	
Work with exhibit curator to ensure concerns are addressed	
Models	
Identify and obtain one or more of the following:	
Dioramas	
Reconstructions	
Graphics	
Charts	
Illustrations	
Maps	
Multi-media	
Exhibit Fabrication	
Display systems	
Hardware	
Lumber	
Paint	
Multi-media equipment	
Electrical fixtures	
Fabric/textiles	

Figure 7.3. Park Exhibit Checklist

Photographs <ul style="list-style-type: none"> • black and white • sepia • color 	
Framing and matting	
Banner/title poster	
Marquees/signs/labels	
Production and Installation	
Work with preparator and conservator to install the exhibit	
Change object status and location in ANCS+	
Develop monitoring schedule	
Prepare list of problems to be corrected	
Correct problems	
Maintenance	
Obtain a maintenance manual	
Develop maintenance schedule	
Ensure access for cleaning, lighting, object rotation and emergencies	
Implement monitoring schedule	
Public Programming	
Prepare and disseminate a news release	
Develop an exhibit brochure or catalog	
Organize an exhibit opening	
Do community outreach	
Develop school program and kits	
Train volunteers and student interns	
Develop a Web feature of the exhibit	

Figure 7.3. Park Exhibit Checklist

Exhibit Conservation Checklist

A. Exhibit Planning

Integrating Conservation into the Exhibit Process

- Integrate conservation early in the exhibit planning phase.
- Provide adequate time and resources.
- Search for balanced conservation solutions.

The Exhibit Team

- Work cooperatively with the team.
- Utilize supportive design staff who have conservation experience.
- Require detailed plans that specify performance criteria.

The Role of the Exhibit Conservator

- Include an exhibit conservator on the exhibit team.
- Involve the exhibit conservator in the earliest stages of the process.

Selecting Objects

- Select appropriate display objects. Avoid selecting too many objects.
- Take into consideration the aesthetics and treatment requirements of each object.
- Avoid permanent exhibit of objects.
- Allow enough time and resources to safely prepare, mount, install, or replicate exhibit objects.

Establishing Conservation Criteria

- Determine the conservation needs of each individual object chosen for display.
- Establish necessary but realistic conservation criteria for display.
- Incorporate the conservation criteria into exhibit design.

Collections Management

- Ensure safe handling of objects in all phases of exhibit development.
- Stabilize all objects according to need.
- Include the appropriate documentation for each object.
- Protect objects during photography.

B. General Design

Multilevel Conservation Response

- Design for environmental stability and protection.
- Consider both macro and micro approaches.
- Choose an appropriate level of response from the multiple options.

Exhibit Format and Layout

- Use enclosed display when possible.
- Allow sufficient room for traffic flow.
- Group objects that have similar conservation criteria.

Figure 7.4. Exhibit Conservation Checklist (*Note:* Checklist is based on a document developed by HFC, Department of Conservation.)

Temperature and Relative Humidity

- Obtain baseline information about the temperature and relative humidity.
- Control the environment within the entire exhibit space.
- Locate sensitive objects in the most stable locations.
- Provide additional control for sensitive objects.

Particulate Contamination

- Monitor pollutants and enclose sensitive collections.
- Use high-efficiency filters in environmental systems.
- Use localized filtration equipment as needed.

Chemical Pollutants

- Monitor pollutants and enclose sensitive collections.
- Incorporate chemical filters in the environmental systems.
- Provide air circulation.
- Select stable construction materials.
- Aerate the exhibit space before object installation.

Exhibit Lighting

- Develop a lighting plan that responds to conservation criteria.
- Limit total light exposure.
- Filter all sources of ultraviolet radiation.
- Control infrared radiation.
- Exclude sunlight.
- Construct lighting mockups.

Biological Infestation

- Examine objects for signs of infestation and active mold.
- Design exhibits to inhibit infestations.
- Enclose objects when the risk of infestation is high.
- Avoid introducing insects through props and unchecked exhibit materials.
- Control human behaviors that encourage infestation.

Physical Security

- Conduct a risk assessment.
- Provide the appropriate level of protection.
- Use tamper-resistant hardware.
- Facilitate authorized curatorial access to the objects.

Emergency Preparedness and Fire Protection

- Develop fire protection and emergency response plans.
- Perform a risk assessment and address potential problems.

Figure 7.4. Exhibit Conservation Checklist (*Note:* Checklist is based on a document developed by HFC, Department of Conservation.)

C. Exhibit Case Design

Designing a Conservation-Grade Case

- Design cases as protective enclosures.
- Establish performance criteria.
- Provide detailed, explicit drawings and specifications.
- Build and test complicated case designs as prototypes when possible.
- Test the fully assembled case in its final location.

Case Stability, Security, and Access

- Construct a physically stable, structurally secure case.
- Provide appropriate security features.
- Ensure practical access design for curatorial entry.

Sealed Exhibit Cases

- Use sealed display cases when appropriate.
- Design well-sealed cases with tight joints and with gaskets.
- Use conservation-appropriate sealants.
- Test case performance.

Ventilated Exhibit Cases

- Use ventilated cases for appropriate applications.
- Control the design and construction of ventilated cases.
- Use positive-pressure cases when appropriate.

Lighting Design within Cases

- Develop a case lighting plan and specify appropriate lighting equipment.
- Isolate lights from the display chamber.
- Reduce heat gain and temperature cycling.
- Incorporate heat-reflecting and insulating materials when necessary.

Humidity-Control Principles

- Provide a well-sealed case that will support humidity control.
- Ensure adequate air circulation within the case.
- Provide separate access to the environmental maintenance chamber.
- Test the case before enclosing objects.
- Monitor the interior relative humidity for the duration of the exhibit.

Active and Passive Humidity-Control

- Establish whether the goal is stabilization or control.
- Select an appropriate passive or mechanical system.
- Provide safeguards for mechanical systems.
- Include appropriate and sufficient moisture-absorber medium for passive control.
- Test and monitor the case.

Figure 7.4. Exhibit Conservation Checklist (*Note:* Checklist is based on a document developed by HFC, Department of Conservation)

<p>Pollution-Control Systems</p> <ul style="list-style-type: none"><input type="checkbox"/> Incorporate enough absorber to remove pollutants for six months to one year.<input type="checkbox"/> Ensure unrestricted airflow.<input type="checkbox"/> Provide access to change the absorber.<input type="checkbox"/> Maintain the absorber. <p>D. <u>Installation and Maintenance</u></p> <p>Choosing Conservation-Appropriate Materials</p> <ul style="list-style-type: none"><input type="checkbox"/> Select conservation-safe materials for case construction.<input type="checkbox"/> Avoid adhesives within the object display area.<input type="checkbox"/> Review the composition of commercial interior finishes.<input type="checkbox"/> Allow sufficient curing time before installing objects.<input type="checkbox"/> Isolate objects from painted or varnished surfaces.<input type="checkbox"/> Select and attach decorative fabrics carefully. <p>Using Less Stable Materials</p> <ul style="list-style-type: none"><input type="checkbox"/> Use the least hazardous material available, and isolate objects from them.<input type="checkbox"/> Aerate the case after applying coatings and sealants.<input type="checkbox"/> Isolate objects from problematic surfaces.<input type="checkbox"/> Incorporate a pollutant absorber or scavenger. <p>Design and Fabrication of Exhibit Mounts</p> <ul style="list-style-type: none"><input type="checkbox"/> Design and fabricate mounts for object installation ahead of time.<input type="checkbox"/> Protect the integrity of the object.<input type="checkbox"/> Support the entire object to avoid physical stress.<input type="checkbox"/> Provide adequate support for flexible objects.<input type="checkbox"/> Support all parts independently over as large an area as possible.<input type="checkbox"/> Stabilize objects from vibration.<input type="checkbox"/> Ensure the security of framed works. <p>Exhibit Production and Object Installation</p> <ul style="list-style-type: none"><input type="checkbox"/> Avoid transporting objects into production areas.<input type="checkbox"/> Inspect exhibit assemblages that affect objects during the production phase.<input type="checkbox"/> Complete construction before object installation.<input type="checkbox"/> Evaluate the exhibit team's performance. <p>Exhibit Maintenance</p> <ul style="list-style-type: none"><input type="checkbox"/> Provide a maintenance manual that includes the conservation criteria.<input type="checkbox"/> Monitor exhibit conditions.<input type="checkbox"/> Perform necessary maintenance to ensure the continued performance.<input type="checkbox"/> Keep the exhibit area clean.<input type="checkbox"/> Plan ahead for the safe movement of objects.

Figure 7.4. Exhibit Conservation Checklist (*Note:* Checklist is based on a document developed by HFC, Department of Conservation.)

Chapter 8: Using Museum Collections in Historic Furnished Structures

	<u>Page</u>
A. Overview	8:1
What information does this chapter cover?.....	8:1
What doesn't this chapter address?.....	8:1
What is a historic furnished interior?.....	8:2
What do historic furnishings include?.....	8:2
What types of historic furnishing installations are there?.....	8:3
B. Finding Background Information to Furnish a Historic Structure	8:4
What NPS documents contain information relevant to historic furnishings projects?.....	8:4
What other sources should I research?.....	8:6
Where do I go for help when planning to furnish a historic interior?.....	8:6
What services do I need in a historic furnishing curator?.....	8:6
What services does Harper Ferry Center Department of Planning and Research provide?.....	8:7
C Getting Started	8:8
When does a historic furnishing project happen?.....	8:8
Why is research on historic structures useful?.....	8:8
Why establish a historic furnishings team?.....	8:9
Who is on the historic furnishings team and what does each member do?.....	8:9
Who writes the historic furnishings report.....	8:12
D. Planning Historic Furnishings Projects	8:12
What is NPS policy on furnishing a historic interior?.....	8:12
What are some general guidelines to developing a furnished historic interior?.....	8:13
How do we determine what kind of historic furnishings are needed?.....	8:13
What initial planning actions does the park take?.....	8:15
What does the project curator once the initial planning is completed?.....	8:15
How are themes and goals developed?.....	8:16
Why does the park need a project agreement?.....	8:17
When does the park work with a contract furnishings curator to develop a historic furnishings report?.....	8:18
What is included in a historic furnishings plan?.....	8:18
How do I estimate costs to prepare a furnishings plan?.....	8:19
How do I estimate costs to implement a historic furnishings plan?.....	8:20
What sources can be used to fund historic furnishings projects?.....	8:20
E. Producing and Installing Historic Furnishings	8:21
How is the historic furnishings production process initiated?.....	8:21
What steps are involved in planning and production?.....	8:22
What steps are involved in historic furnishings installations?.....	8:23
Should I develop a punch list after the installation?.....	8:24
How do I correct minor factual errors after installation?.....	8:24
F. Preservation and Maintenance of Historic Furnished Structures	8:25
What object preservation issues must I consider when furnishing historic interiors?.....	8:25
What preservation challenges do furnished historic interiors present?.....	8:25
How can I protect museum collections from light damage?.....	8:26
How do I protect museum collections from environmental damage?.....	8:26
Can object placement help protect objects on exhibit?.....	8:26
What should I do about visitors and traffic flow?.....	8:27
What safety and security precautions should I take?.....	8:28

What do I need to know about structural preservation issues?.....	8:28
What happens immediately after the project is installed?.....	8:29
Should I monitor object condition?.....	8:29
What do I need to know about housekeeping?.....	8:29
What opening and closing procedures do I need to implement?.....	8:30
G. Documenting Historic Furnishings on Exhibit	8:30
Should objects in the furnished historic interior be cataloged?.....	8:30
When should I arrange for illustrations for artwork?.....	8:30
What documentation do I need for objects undergoing conservation treatment?.....	8:31
When should I borrow objects for installation?.....	8:31
When do I need to insure objects?.....	8:31
Do I need to annually inventory items on exhibit in the furnished historic interior?.....	8:31
What do I need to know about acquiring images?.....	8:31
What photographs do I need?.....	8:31
How do I handle requests to photograph the historic furnishings installation or the objects?.....	8:32
H. Interpreting Furnished Historic Interiors	8:32
Why are furnished historic interiors used to interpret park resources?.....	8:32
What is the Comprehensive Interpretative Plan?.....	8:32
What types of interpretation do historic furnished interiors provide?.....	8:33
What time periods are interpreted in the furnished historic interior?.....	8:33
What are some of the methods of interpreting historic furnishings?.....	8:34
How can the project curator assist with interpretation of the historic furnishings?.....	8:34
Who is involved in interpreting the historic furnishings installation?.....	8:34
How does the park answer inquiries from staff, visitors and the public?.....	8:34
I. Evaluating Historic Furnishings	8:35
How do I evaluate the historic furnishings installation?.....	8:35
What is preliminary evaluation?.....	8:35
What is planning and production evaluation?.....	8:36
What is post-production evaluation?.....	8:36
J. Rehabilitating Historic Furnishings Installations.....	8:37
What should I do when objects show signs of wear?.....	8:37
How do I update the historic furnishings installation?.....	8:37
K. Selected Bibliography	8:37
L. List of Figures	8:39

Chapter 8: Using Museum Collections in Historic Furnished Structures

A. Overview

1. *What information does this chapter cover?*

This chapter covers historic furnishings that are displayed in historic structure museums, historic house museums, historic structures, and rooms within museum settings. This chapter replaces the NPS *Museum Handbook*, Part III, Furnished Historic Structure Museums, January 1968.

The chapter only addresses museum collections themselves that are displayed in furnished historic structures. Please refer to Chapter 7, Using Museum Collections in Exhibits of this Handbook for detailed information on issues related to the exhibition of museum collections in areas such as visitor centers, galleries and exhibit halls.

The chapter assumes that the restoration or reconstruction of a historic furnished interior is the optimum way to convey the park's interpretive mission. NPS sites provide a unique opportunity for the public to see the 'real things' in the actual places where American history happened. Historic furnished structures provide the original context for visitors to link directly to individuals and events celebrated in the national park system.

Follow the procedures outlined in this chapter when furnishing a historic interior, whether you do the work in-house, or use a contractor or Harpers Center staff.

2. *What doesn't this chapter address?*

The chapter does not include information on exhibits in:

- traditional museum settings such as exhibit halls and galleries
- office art or display of museum collections in administrative offices
- visible storage
- wayside exhibits
- traveling exhibits

Also, the chapter doesn't address structural and interior issues such as:

- structural assessment and treatment
 - load bearing characteristics
 - safety codes
- interior and exterior treatments or configurations
 - period architectural features

- paint and wallpaper analysis
- handicapped access
- carrying capacity including tour routes
- adaptive use of historic structures

Refer to Director's Order # 28: Cultural Resource Management Guideline, Chapter 8, Historic and Prehistoric Structures for information on these topics.

3. *What is a historic furnished interior?*

Historic furnishings are the combination of historic spaces, objects and themes. They evoke a powerful interpretive experience for visitors who can sense that 'history happened here'

Planning a Historic Furnishings Report, Harpers Ferry Center

A historic furnished interior is an assemblage of furnishings arranged in a historic structure. The historic structure can include original furnishings with intact architectural features, or it may be a restored interior with some original furnishings; or it can be a recreated or reconstructed interior without original furnishings. Period rooms in a museum aren't considered historic furnished structures. See NPS 28, Cultural Resource Management Guideline, Chapter 8. A.1, for a definition of a historic structure.

The ultimate goal of any furnishings project is to create an authentic furnished historic exhibit for interpretation. Whether a domestic interior, machine shop, store, military barrack, or ship's wardroom, objects must be installed to ensure an accurate historical scene. Display site-associated furnishings in the original structure in which they were made or used. If appropriate, site-associated furnishings can be supplemented by period pieces or replicas. Furnish historic interiors with a maximum amount of accuracy and a minimum of conjecture. Refer to the guidelines at www.nps.gov/hfc/products/furnish/furnish-plan.htm and the *NPS Northeast Region's Guidelines for the Treatment of Historic Furnished Interiors* for additional information.

4. *What do historic furnishings include?*

Historic furnishings include the following:

- original objects and furnishings directly associated with the site, referred to as "original" objects
- objects and furnishings dating to the period, referred to as "period" objects
- floor coverings
- wall coverings
- window treatments
- reproduction objects and furnishings, including floor coverings, wall coverings, and window treatments

- accessory items used to represent the appearance of an area to a date or period of time specified by a site’s interpretive plan.

Historic furnishings on exhibit in furnished historic interiors are considered museum collections. This applies to original, period, and reproduction objects. They are all documented, preserved and used in accordance with procedures outlined in the NPS Museum Handbook, Parts I, II, and III.

Historic furnishings may be directly associated with an individual or a group while at that site, or an event or activities that occurred at the site. This includes personal items that Frederick Douglass used at his Cedarhill home or that Eleanor Roosevelt used at Val-Kill. These are considered “original” to the site. Historic furnishings that are called “period pieces,” date to the same era without having direct association with the specific people, events, or activities related to the structure itself. Always inform visitors as to which objects are original to the site, period pieces, and reproductions. Whether you have directly associated, period or reproduction pieces, furnished historic interiors present a management challenge. In addition to balancing the needs of preservation and use of museum collections, you need to balance the museum collection needs with those of the historic structure that houses the collection.

5. *What types of historic furnishing installations are there?*

There are different kinds of furnished historic structure installations. They include:

- Homes of prominent individuals such as presidents and other national leaders. Examples include homes of Abraham Lincoln Home, Franklin Delano Roosevelt, Harry S. Truman, and Frederick Douglass.
- Homes of less well-known individuals such as Maggie Walker or Moore Cabin at Skagway NHS.
- Institutional living quarters such as military barracks, officer quarters, and barracks at Manzanar NHS, Fort Laramie NHS and Fort Davis NHS.
- Stores such as clothing, rug room and dry goods stores at Hubbell Trading Post NHS.
- Inns and taverns. These include Lemon House at Allegheny Portage NHS and Mount Washington Tavern at Fort Necessity NHS.
- Industrial-related sites such as the forge at Saugus NHS, Cast House at Hopewell Furnace NHS, machine shop at Edison NHS.
- Ships such as the USS *Cassin Young* and *Balclutha*.
- Period settings within exhibit areas such as the Civil War encampment at Gettysburg National Park.

Visitors can see these installations at the park or online in virtual exhibits on

the park's home page and at the NPS Museum Management Program's (MMP) web site at www.nps.gov/history/museum.

B. Finding Background Information to Furnish a Historic Structure

1. What NPS documents contain information relevant to historic furnishings projects?

The NPS documents noted in this section contain useful information for successfully completing a park historic furnishings project. Refer to *MH-III*, Chapter 7, Using Museum Collections in Exhibits for specific guidance on exhibit and conservation related issues. Before starting a historic furnishings project, become familiar with museum collections-related sections in the NPS policies and guidelines noted below

- *NPS Management Policies*, Chapter 5.3.5.5.5, Historic Furnishings:

When historic furnishings are present in their original arrangement in a historic structure, every effort will be made to preserve them as an entity. Such historic furnishings will not be moved or replaced unless required for their protection or repair or unless the structure is designated for another use in an approved planning document. The original arrangement of historic furnishings will be properly documented. A structure may be refurnished in whole or in part if:

- all changes after the proposed refurnishing period have been professionally evaluated, and their significance has been fully considered
- a planning process has demonstrated that refurnishing is essential to public understanding of the park's cultural associations; and
- sufficient evidence of the design and placement of the structure's furnishings exists to enable its accurate refurnishing without reliance on evidence from comparable structures.

Generalized representations of typical interiors will not be attempted except in exhibit contexts that make their representative nature obvious. Reproductions may be used in place of historic furnishings, but only when photographic evidence or prototypes exist to ensure the accurate recreation of historic pieces.

- NPS-28: Cultural Resource Management Guideline, Chapter 8. Historic and Prehistoric Structures discusses management, preservation, treatment and interpretation of historic and prehistoric structures, and furnished historic structures, and Chapter 9, Management of Museum Objects, covers the historic furnishings report, historic furnishings, and the relationship of objects to the historic structure, as well as standards for managing objects.

- Director's Order #6, 3.5 Interpretation and Education, notes that Harpers Ferry Center (HFC) will: "*Provide assistance with the development of interpretive media in.... historic furnishings ...*" and discusses the elements of interpretive planning.

- *Interpretation and Visitor Services Guideline* (formerly NPS 6),

Chapter 5, Section 2, Exhibit Design, Production and Rehabilitation discusses the development or rehabilitation of exhibits.

- *Project Management Information System* (PMIS) is a Servicewide budget system used for project requests.

Park-specific documents:

- *General Management Plan* (GMP) outlines interpretive themes, proposes locations for informational and interpretive facilities, examines visitor needs and use trends, and sets the general direction for resource interpretation, preservation and visitor use. The GMP specifies the need, in broad terms, for a furnished historic structure.
- *Comprehensive Interpretive Plan* (CIP) identifies all interpretive themes and needs in the park and includes a long-range interpretive plan or strategy, the annual interpretive plan, and a park interpretive database that compiles various interpretive data.
- *Long Range Interpretive Prospectus* (LRIP) is part of the CIP that is developed for a specific project. It describes in detail what areas will be furnished, how they will be furnished, and how they will be interpreted.
- *Historic Resource Study* is the primary document used to identify and manage historic resources in a park. It is the basis for understanding the significance and interrelationships of historic resources. The Historic Resource Study provides a point of departure for development of interpretive plans and the framework within which additional research should be initiated. It documents sources of primary and secondary materials of potential value to the study.
- *Historic Structures Report* is the primary guide to treatment and use of a historic structure. It outlines information on the historic structure's evolution, current condition and causes of deterioration based on documentary research and physical examination. It presents and evaluates alternative uses and treatments, and compiles a record of treatments. It includes an architectural data section documenting changes to the historical fabric of the structure; and outlines the history and use, archeological investigations, and structural analysis of items such as paint and wallpaper.
- *Historic Furnishings Report* [HFR] is the primary guide to furnishing a historic interior. It outlines the plan for furnishing the interior and provides the basis for those plans. The HFR provides detailed information critical to furnishing and managing the structure. In particular, it provides background, history, occupancy, and use over time, and documents, where possible, previous furnishings. The HFR provides the interpretive objectives of the project, listing of recommended furnishings, sources, and a comprehensive installation plan. It includes how much documentation exists for the structure, and addresses how visitors will experience the site, and how the plan will be implemented. Guidelines on preparing a historic furnishings report are found at www.nps.gov/hfc/products/furnish/furnish-plan-hfr-guide.htm.

- *Archeology Report* that documents objects recovered at the park site using archeological recovery methods.
- *Museum Catalog Record* that documents individual items or groups of items in the park's museum and archival collections, and is contained in the park's Automated National Catalog System database (ANCS+ or its successor).
- *Project Management Information System (PMIS) Project Statement*, the project statement in PMIS documents the work to be done, the funding request, funding received, and accomplishments.

2. *What other sources should I research?*

An authentically furnished historic interior tells a compelling story of its inhabitants. The people who lived and worked in, and who used this historic interior come alive when the real historical context is recreated. To do this, you need to systematically research general histories, in-depth historical studies, state, regional and local histories, county and city records such as tax and census returns, courthouse records, building and property records, architectural records, archeological excavation field notes and records, inventories, and museum and archival records.

Read dairies, journals, work logs, and biographies. Closely examine visual images such as portraits and room sketches. Historic photographs provide rich evidence for furnishing historic interiors accurately. Identify the paints, wallpapers, window and floor coverings and other materials used in the structures. Understand use patterns. Preserve the human element of the structure to tell the story. Whenever possible, do audio and video tape interviews of people who were directly associated with the structure, or who are descendents of, or connected to the original inhabitants.

3. *Where do I go for help when planning to furnish a historic interior?*

When initiating a new historic furnishings installation or exhibit or updating an existing one, consult with your regional curator, regional chief of interpretation, and other regional specialists, such as the historical architect, and NPS specialists in historic furnishings; research and object acquisition, including those at Harpers Ferry Center. You can gain valuable practical advice by talking to other NPS colleagues who have been involved in historic furnishings projects. Speak to curators, collections managers, registrars, historians and exhibit designers at local and regional historic house museums and historical societies. The American Association for State and Local History (www.aaslh.org) and the National Trust for Historic Preservation (www.nthp.org) publications provide useful information on interpreting historic properties. Many of their publications are available online.

4. *What services do I need in a historic furnishings curator?*

The historic furnishings curator, also called the project curator, project manager or historic furnishings planner, ensures that the public sees an accurate picture of the people, activities and events that the park is interpreting. The historic furnishings curator acquires and installs original, period, and reproduction objects to recreate the documented interiors. These include furnishings, decorative arts, personal items, custom reproductions, wallpaper, carpeting and drapery. The historic furnishings curator participates in interpretive planning teams and proposes furnishings alternatives to the park. He or she recommends sources for historical and reproduction objects, and provides useful advice and information about a

broad range of historic furnishings related activities and services. This includes research, planning, acquisition, installation, and post-installation support.

The historic furnishings curator:

- documents interiors and furnishings for whole buildings or individual spaces in houses, shops, ships, military barracks, courtrooms, taverns, forts, stores, mills and other structures
- develops plans to acquire and install original, period, or reproduction furnishings
- coordinates the work of contract curators who prepare historic furnishings plans, if appropriate
- coordinates the installation or rehabilitation of historic furnished interiors
- coordinates the efforts of architects who prepare historic structures to receive furnishings
- coordinates the efforts of object conservators who clean, repair, and prepare historic furnishings for exhibit
- works with park curatorial staff to develop an object rotation plan
- recommends placement of furnishings to maximize preservation and enhance visitor flow
- trains park curatorial and interpretation staff on the use and interpretation of interiors
- provides advice about operating historic structure museums

5. *What services does Harpers Ferry Center, Department of Planning and Research provide?*

Harpers Ferry Center [HFC] Department of Research and Planning staff research and document the historical appearance of a wide range of structures in the national park system. Their work enables the park to present authentic furnished interiors that commemorate significant individuals and everyday people and events in the national park system. HFC historic furnishings staff provide useful advice and information about a broad range of historic furnishings related activities and services. Services include research, planning, acquisition, installation, and post-installation support.

There is extensive information on a wide range of historic furnishings topics, including how to produce a historic furnishings plan, and guidelines for preparing historic furnishings reports at <http://www.nps.gov/hfc/products/furnish/index.htm>.

C. Getting Started

1. *When does a historic furnishings project happen?*

A historic furnishings project typically occurs when the park identifies a need to interpret an individual or group, an era, event or activities using furnishings in a historic structure. Furnishings projects are triggered by:

- the creation of a new park
- new planning initiatives (GMPs, LRIPs, etc.)
- rehabilitation of existing structures
- new discoveries and new interpretations in research or original collections

The elements noted below are needed to proceed with a historic furnishings plan:

- significant park theme
- original structure
- collections original to the site and structure(s)

2. *Why is research on historic structures useful?*

Research yields background information vital to management decisions. It provides the history, context and detail needed to authentically furnish the interior of a historic structure. Research enables the park to interpret the structure and its interior. Most importantly, it provides documentation on the people who lived or worked there. Research provides specific information on the historic character and use of the structure at a particular time and over time; historic objects and their placement; materials, finishes, fixtures, features; construction techniques, additions, alterations, and spaces and spatial relationships. See B.2. for sources of information.

Research on historic structures is collected, analyzed and documented using the following steps:

Step 1: Identification, evaluation and registration

Historical areas of the national park system are listed in the National Register of Historic Places (www.nps.gov/history/nr) when they are established by law or executive order. Individual structures or features within these areas that contribute to their historical significance must also be documented for National Register purposes. A *Historic Structures Report* is usually completed. It provides essential information needed to furnish the interior. Refer to NPS- 28, *Cultural Resource Management Guideline*, Chapter 8, Historic and Prehistoric Structures for information on what is required to identify, evaluate and register a historic structure in the National Register.

Step 2: Documentation and investigation

Historic structure research complements existing knowledge needed to make informed decisions. Research on thematic context, physical

documentation, temporal associations, developmental history, scientific value and material analysis is critical to managing the historic structure, and to furnishing it. Historic documents, drawings, photographs, and paintings yield information. Information is also culled from other reliable sources. The *Historic Structures Report* (HSR) is usually completed for significant historic structures. Refer to NPS-28, *Cultural Resource Management Guideline*, Chapter 8, Section 2.a. *Historic Structures Report* for information on what is included in this report.

3. *Why establish a historic furnishings team?*

A successful historic furnishings project is a team effort. It involves a broad range of expertise. Not all members are equally active at the same time. However, each team member's input is essential to ensuring a successful project. The entire team ensures that a plan is well developed and accurate. It ensures that the historic furnished interior satisfies the visitors' and the park's needs. The team is usually composed of park and center staff, or contract staff.

4. *Who is on the historic furnishings team and what does each team member do?*

The team may include any of the following individuals noted below. Although responsibilities are assigned to each team member, the team synergy ensures that a comprehensive, in-depth historic furnishings report is developed, and an authentic and compelling interior furnished.

- *chief of interpretation* :
 - recommends the number of areas to be furnished
 - proposes the period of interpretation
 - suggests methods of interpretation including audio tours and interpretive labels
 - develops tour routes
 - recommends development of complementary programs and media, such as a web exhibit and *Teaching with Museum Collections* lesson unit plans, and posting of the objects in the Web Catalog at <http://www.museum.nps.gov>
 - functions as the furnishings project liaison with the park superintendent
- *historic furnishings curator* [also called the project curator, project manager or historic furnishings planner]
 - conducts the actual research leading to a historic furnishings report
 - meets with park staff to set goals on what will be accomplished
 - establishes, with park staff, the deadlines for the accomplishment of those goals
 - examines park museum and archival collections
 - identifies objects for their relevance to the project

- identifies, together with park curatorial staff, additional objects for rotation to enhance object preservation
- examines sources external to the park for information relevant to the project
- provides the park curator with descriptive and documentary material and digital images of objects to include in new or revised catalog records
- coordinates, together with park curatorial staff, the development of related web features
- *park curator who*
 - recommends appropriate collections for inclusion
 - accessions and catalogs the collections, and submits records for posting in the Web Catalog
 - provides pertinent information on selected objects
 - selects objects for exhibit and rotation in consultation with the conservator and historic furnishings curator
 - provides historic, contextual, preservation and other pertinent information on selected objects and how they relate to the interpretive themes of the furnished historic structure
 - documents the objects are on exhibit
 - monitors the condition of objects on exhibit
 - trains staff in housekeeping for historic furnished structures
 - conducts regular inventories of objects on exhibit
 - trains housekeeping staff on how to work in exhibit areas
- *conservator*
 - examines objects in the collections proposed for exhibit
 - determines whether those objects will withstand the stress and demands of exhibit
 - provides a schedule for rotating and “resting” sensitive objects off exhibit and develops a list of alternate objects for exhibit in consultation with the park curator
 - indicates what stabilization or remedial treatment they need in order to be put on exhibit

- arranges for conservation treatment either at HFC or through a contract conservator.
- *superintendent*
 - approves historic furnishings projects
- *chief of maintenance*
 - advises on structural, electrical, and related furnished historic structure preservation issues
 - has responsibility for ensuring exhibit areas are kept clean
 - works closely with the park curator and chief ranger to keep collections on exhibit preserved and protected
 - orients appropriate fire department officials to the layout and special needs of the site, and tours them through the structure
- *chief ranger*
 - ensures that intrusion and fire alarms and suppression systems are working and routinely tested
 - ensures that objects on exhibit in the furnished historic structure are included in the park's emergency preparedness plan
 - trains park staff to respond to alarms sound and emergencies
 - instructs staff in fire prevention, protection and the use of portable ABC rated fire extinguishers

Other specialists on the team may include:

- archivist
- educator
- historian
- historical architect
- media specialist
- registrar
- subject-matter experts

Descendents, family members and workers familiar with the site should meet with the team, as appropriate.

5. *Who writes the historic furnishings report?*

There are several options for the park to write the historic furnishings report. The park may choose to have:

- qualified park staff develop and implement the historic furnishings project;
- contract with a private historic furnishing specialist to write a historic furnishings report and develop a new historic furnishings exhibit or upgrade an existing exhibit; or
- enter into an agreement with NPS center staff to write the report.

Whatever option is selected, the park needs to meet conditions outlined in Figure 8.3, Sample Agreement between Harpers Ferry Center, Division of Historic Furnishings and a Park. This agreement outlines participant roles, work assignments, and products entailed in developing the historic furnishings exhibit.

D. Planning Historic Furnishings Projects

1. *What is NPS policy on furnishing a historic interior?*

NPS Management Policies, Chapter 5, Section 5.3.5.5.5 provide professional historic furnishings guidelines. The policies state:

When historic furnishings are present in their original arrangement in a historic structure, every effort will be made to preserve them as an entity. Such historic furnishings will not be moved or replaced unless required for their protection or repair, or unless the structure is designated for another use in an approved planning document. The original arrangement of historic furnishings will be properly documented. A structure may be refurnished in whole or in part if:

- *All changes after the proposed refurnishing period have been professionally evaluated, and their significance has been fully considered;*
- *A planning process has demonstrated that refurnishing is essential to public understanding of the park's cultural associations; and*
- *Sufficient evidence of the design and placement of the structure's furnishings exists to enable its accurate refurnishing without reliance on evidence from comparable structures*

Generalized representations of typical interiors will not be attempted except in exhibit contexts that make their representative nature obvious. Reproductions may be used in place of historic furnishings, but only when photographic evidence or prototypes exist to ensure the accurate re-creation of historic pieces.

2. *What are some general guidelines to developing a furnished historic interior?*

The presentation of interiors and furnishings, and the surrounding landscape within a single timeline is a core preservation value.

When developing a furnished historic interior, always:

- Substantiate all furnishings and interiors with documentary and physical evidence.
- Preserve the original contents, such as objects and furnishings; features, finishes, and fabric of the interior.
- Accession original objects into the museum collections in accordance with the park's scope of collections statement.
- Take representative samples of features, finishes, fabrics and other furnishings, and add to the park's museum collection.
- Maintain the original distinguishing qualities or character of the interior. Don't remove or alter historic material or distinctive features.
- Ensure reversibility if historical material or distinctive features are altered. Thoroughly document any changes.
- Recognize, document, and respect changes that have taken place over time. They provide evidence of the history and development of the historic interior.
- Repair rather than replace deteriorated materials, features, finishes and furnishings. However, if the object is too deteriorated, rather than causing further damage, replace it in the exhibit and place what remains of the original in storage.
- Ensure that new and replacement items always match the old in design, color, texture, and where possible, original material.
- Substantiate and document replacement of missing features, finishes, materials, and furnishings.
- Use professionally accepted methods of preservation, conservation, preventive maintenance and object handling procedures for museum collections on exhibit in the historic furnished interior.
- Ensure furnishings and interiors complement each other in accordance with the historic furnishings plan.

3. *How do we determine what kind of historic furnishings are needed?*

Develop an interpretive statement that describes what story will be told and what the public will see on display. The statement outlines what period, people, activity or processes will be interpreted, and what historic furnishings are needed. All decisions related to the project flow from this statement. The steps noted below enable the historic furnishings curator to determine what kinds of historic furnishings are needed.

Step 1: Assess the park collection assessment and determine gaps
The documented original contents of the interior to be furnished determine

what historic furnishings are needed. The interior should always be furnished with the minimum of conjecture. The interior space itself also determines what furnishings are needed. The park may choose to furnish the entire structure, such a presidential home or a single area such as a drugstore counter. The interior needs to be furnished in a way that allows visitors see to the furnished space under practical operating conditions. The project curator works closely with the park to establish project parameters.

In accordance with *NPS Management Policies* and NPS 28, *Cultural Resource Management Guideline*, if original furnishings survive, and if their interpretation is critical to an exhibit, then their use is appropriate. However, if original furnishings don't exist, furnishing a historic interior may present significant challenges and problems. In these instances, the decisions on whether to furnish must be judged on a case-by-case basis. The project curator determines the gaps in the park collections relative to the project.

A furnishing project generally combines the use of museum collections directly associated with the structure with the use of period pieces and reproductions. The higher the number of original items included in the interior, the greater its integrity. Period pieces such as couches, chairs, decorative arts, and archival and manuscript collections are used in historic furnished structures. The project curator will need to determine what objects need to be acquired or reproduced.

Step 2: Determine the appropriateness of objects for use

Whenever possible, use items that are original to the structure. To ensure longevity, identify similar objects that will be rotated regularly into the exhibit in order to 'rest' the objects. This rotation slows deterioration that occurs from extended exposure. Use documentary evidence to establish what objects to include. This includes historic photographs, paintings, drawings and documents, including inventories, memoirs, letters, and invoices.

When using period pieces, make sure that the pieces are appropriate to the period, location, and socio-economic standing of the people and place being furnished. The furnishings must be consistent with the interior and the historic structure. Wallpaper, window treatments and floor coverings are often reproductions because their originals have not survived, or have been placed in storage for preservation purposes. Accession and catalog representative samples of original wallpaper, window treatments and floor coverings into the park's museum collection. Natural history specimens are less commonly used, although items such as taxidermy mounts, geological samples, and seashells that were once fashionable may be used in furnished historic structures.

Step 3: Determine availability of objects

Make every effort to acquire objects that are original to the site. Period pieces may be acquired to supplement original collections to fully interpret the site. If the site doesn't already own the original furnishings, the project curator researches the acquisition and use of appropriate period pieces for inclusion in the historic interior. The park should make every effort to acquire original furnishings and period pieces by donation, purchase, or trade.

Step 4: Assess condition of available objects

Selected items should be in good condition to ensure the interpretive story is enhanced. Original or period items need to be stable enough to tolerate the exhibit environment. They may need conservation prior to exhibition. Develop a rotation schedule that allow original items to ‘rest,’ thereby extending the object’s preservation. Refer to Section F, Preservation and Maintenance, and Chapter 7. H. Exhibit Conservation, for additional information on preservation and conservation.

4. *What initial planning actions does the park take?*

The park determines whether a staff member, HFC historic furnishings curator, or a contractor will develop a historic furnishing plan. The project manager should:

- consult with the park team
- review the park’s interpretive plan and museum collections documents
- draft a project agreement for review by the park. Refer to Figure 8.3- Sample Agreement between Harpers Ferry Center, Department of Planning and Research and a Park
- develop a project interpretive statement
- coordinate the project among the park, regional office, Denver Service Center, and other HFC media units
- identify funding sources
- develop cost estimates
- consult with designated park staff on the project
- supervise the project through completion

The park works with project curator to develop and implement a historic furnishings plan. Whether the park chooses to do the work in-house, work with HFC staff or a contract curator, the steps outlined below should be followed.

5. *What does the project curator do once the initial planning is completed?*

The project curator:

- reviews site resource studies, planning documents, museum documents, and other pertinent documents for their suitability to the project
- visits the site and meets with the park team, including park interpretation and museum staff
- inspects historic furnishings that are part of the park’s collections
- examines collection documentation including accession and catalog records for museum and archival collections, and evaluates other resource materials at the park
- evaluates the integrity of the spaces to be furnished

- assesses the structure's condition, including environmental controls, fire protection, security or rehabilitation needs
- coordinates with team members at a park, a regional office, other media offices at HFC
- with the park staff, determines requirements for visitors with physical impairments
- measures and photographs rooms to be furnished
- photographs objects to be used
- consults with park staff on any other issues relevant to the project
- writes the historic furnishings report (refer to Figure 8.4, Annotated Guidelines for Preparing a Furnishings Report)
- coordinates the architect, engineer, and curatorial efforts to implement the plan
- implements the plan

6. *How are themes and goals developed?*

The park interpretive plan should guide the project's interpretive themes. These themes are addressed in the specific furnishings project. Other critical tasks are necessary to produce a well conceived furnished historic interior are described below. The project curator, in consultation with park staff:

- conducts research using primary and secondary sources related to
 - the construction history of the building
 - analysis of historical occupancy
 - history of furnishings
 - evidence of room use
 - evaluation of the interiors within the historic framework
 - analysis of changes over time
- identifies tentative themes and approaches based on the park's interpretive plan and enabling legislation
- recommends or confirms recommended period of interpretation
- evaluates objects in park collections for their suitability to the historic furnishings project
- suggests interpretive objectives

- suggests how to transmit themes and goals
- drafts a list of documentary references
- prepares a list of potential objects that need to be acquired for inclusion
- examines documents and collections in local community where appropriate
- reviews general research sources
- reviews visitors surveys and other pertinent visitor research
- identifies sources of historic photographs, graphics, or other potential illustrations from the park collections or other sources
- prepares a draft historic furnishings report for review by the park and other specialists
- issues final report

Refer to Chapter 3, Publications and Chapter 7, Using Museum Collections in Exhibits, for additional information on developing themes and materials for the interpretation of historic furnished structures.

7. *Why does the park need a project agreement?*

The park needs a written project agreement that outlines the specifications of the project. The agreement ensures that all parties have a clear understanding of what needs to be done, products to be produced, and what outcomes are desired. A project agreement is an essential tool in the historic furnishings planning and production process. If HFC is doing the work, a historic furnishings specialist will write the project agreement. If the park is contracting with a private specialist, consult with HFC staff and use the sample in Figure 8.3 when you develop the agreement. The project agreement should include the following:

- background and scope of the project
- project team individual roles and responsibilities
- work plan
- schedule
- budget
- contact information, including phone numbers and e-mail addresses of all involved in the project

8. *When does the park work with a contract furnishings curator to develop a historic furnishings report?*

A park may choose to work with HFC staff, hire a contractor through HFC, or hire a contractor directly. A contract curator may prepare a historic furnishings report when:

- special expertise is needed
- the cost of using a contractor is less than using someone on staff
- HFC furnishings curator is not available to undertake the project

Whichever option is selected, the park should follow the tasks outlined below. The park must work with the park contracting and procurement officer to:

- prepare a scope of work statement
- prepare a requisition
- forward the requisition to the HFC acquisitions management office, if HFC is involved in the project
- evaluate responses of potential contract curators
- coordinate the contract to completion
- ensure that the contract curator performs the work outlined in the project agreement

The project curator prepares a historic furnishings report. Refer to Figure 8.4. Annotated Guidelines for Preparing Historic Furnishings Reports prepared by HFC, Department of Planning and Research for recommended guidelines in preparing a historic furnishings report. Photographs and artwork may be included in the report. The project curator usually contracts for artwork if applicable. The park, HFC staff, and appropriate specialists review the draft. Comments and issues are addressed. The superintendent approves the final report. The report is then distributed.

9. *What is included in a historic furnishings plan?*

The furnishings plan outlines what and where furnishings will be displayed, and how they will be displayed. The document guides the acquisition and installation of museum objects in the furnished historic interior. The historic furnishings report should include the following:

- interpretive objectives
- administrative information
- earlier planning documents
- operating plan
- historical information

- analysis of historic occupancy
- evidence of room use and original furnishings
- archeology reports, if appropriate
- recommended furnishings. This is the core of the plan. This section must include a complete inventory of the structure's proposed contents. The plan outlines the relation of the furnishings to the personalities, activities, interests or other ideas that will be communicated to the visitor.
- alternative recommended furnishings for rotation when selected original recommended furnishings are being rested
- preventive conservation strategy
- documentation of the furnishings, including accession and catalog information
- documentation of the structure
- location and placement of furnishings
- lighting and installation
- source of furnishings
- working drawings
- floor plans and/or elevations
- special installation, maintenance and protection recommendations
- appendixes
- bibliography
- budget
- schedule

Refer to Figure 8.4. Annotated Guidelines for Preparing Historic Furnishings Reports prepared by HFC, Department of Planning and Research and the HFC web site at www.nps.gov/hfc/products/furnish/furnish-plan-hfr-guide.htm.

10. *How do I estimate costs to prepare a historic furnishings plan?*

Costs vary depending on the time needed for research, the availability of research materials, the length of the furnishings report, and whether any specialists need to be hired to supplement the research, and if additional objects need to be acquired. If no preliminary planning has been done on a project (for example, a new park area study), some funding may be necessary to determine what resources are available. When these resources

are known, a more accurate estimate of funding is possible. To provide an estimate of costs, the following questions should be answered:

- What is the availability of research materials?
- Has preliminary planning been done?
- Have objects been cataloged?
- Are objects original to the site available?
- Has the building intended for the exhibit has been rehabilitated?
- Does the structure have a suitable climate-control system and ultra-violet lighting controls ?
- Are fire detection, suppression and intrusion (security) systems in place and operable?

Factor in all aspects of planning and production when calculating costs. Cost elements of planning include:

- salaries and benefits
- travel
- photographs
- illustrations
- editing
- printing

11. *How do I estimate costs to implement a historic furnishings plan?*

The cost of producing a plan involves a number of variables and is complex to estimate. The park museum collections may not have all the furnishings needed to furnish the structure. The park may need to acquire additional museum objects. These objects must be identified, located and purchased. An object may have a low dollar value, but the cost of finding it may be high. Objects original to the site or with significant associational value are often highly priced. Period pieces may be expensive to acquire. Reproduction objects may be easy to locate, but the cost of acquiring them may be high. The cost of making an exact replica can be very high. Objects with an association to the person or event being interpreted may require conservation treatment. Conservation treatment costs are also high. Wall coverings, floor coverings, lighting and other furnishings needed to complete the space may be very costly. Contact HFC to obtain the most accurate, up-to-date estimate of the cost of planning and producing a historic furnishings setting.

12. *What sources can be used to fund historic furnishings projects?*

Line-item funding is a major source for new projects and for the major rehabilitation of existing projects. Congress appropriates line item funds in an annual budget. Rehabilitation funds are sometimes available through regional offices and the HFC. Typically, these pay for the cost of

renovating an existing project. Entrance fee money (sometimes called “fee money” for short) is a source of funding controlled by a park or a region. Cyclic maintenance funds can be used to rehabilitate areas worn from visitation or, for example, degraded from the exposure to light or from other agents of deterioration. Funding can also be found from donations or, increasingly, from grants. Parks have used the following fund sources for work in historic research and object acquisition:

- Annual Operating Funds or Park Base (Recurring)—Fund Type 01
 - Cultural Cyclic Maintenance—Fund Type 01
 - Donations—Fund Type 26
 - Emergency Relief and Storm Damage—Fund Type 04
 - Fee Program—No Year—Fund Type 04
 - Fee Demonstration Program—Fund Type 25
 - Regular Cyclic Maintenance—Fund Type 01
 - Line Item Construction—Fund Type 05
 - Planning—Fund Type 05
 - Congressional Add-Ons
-

E. Producing and Installing Historic Furnishings

1. *How is the historic furnishings production process initiated?*

Whether the park, HFC or a contractor is responsible for the project, the project manager:

- reads the approved historic furnishings report
- consults with the project curator and planner to clarify issues outlined in the report
- meets with park staff
- examines spaces to be furnished to ensure the spaces will be prepared to take objects
- examines paint, carpet, lighting, and wallpaper and other interior features
- examines the park collection to help determine conservation needs
- discusses staffing and security
- discusses barrier types and their placement
- develops a schedule

- coordinates all aspects of work with staff from park, region, HFC and Denver Service Center (DSC)

2. *What steps are involved in planning and production?*

The following steps, usually taken by the project curator, are essential to furnishing a historic structure:

- initial preparation and planning
 - review of historic furnishings report
 - consultation with the planner
 - identification of other specialists needed on the project
 - visit to the site
 - meeting with park staff
 - identification of themes in consultation with park staff
 - establishment of schedule and deadlines
 - cost estimate
 - coordination of all involved in the project, including the park, DSC, HFC, Region, and specialists
 -
- evaluation of condition of furnished spaces
 - arrange for spaces to be prepared for installation, i.e., carpet, lighting, paint, wallpaper
 - establishment of barrier type and design
 - identification of visitor flow
- evaluation of the park collection
 - work with park staff to identify collections
 - work with park curator to prepare park collection(s)
 - organization of objects by category and type (to facilitate buying)
 - development of a ‘want list’ of objects for installation
 - complete work planning for accessioning and cataloging new items (e.g., original, period and reproductions) into the collection
 - determine prototypes for objects to be replaced

- location and acquisition of objects
- contract with known sources to acquire objects
- request donation, loan or purchase of object(s)
- request permission to copy objects, if necessary
- identify contracting officer’s technical representative (COTR) for replication work
- write scope of work statement for reproduction
- send procurement paperwork through system
- arrange for delivery of objects to the conservator; inspects and accepts/rejects objects on completion
- complete object documentation, including accession and cataloging as necessary
- work with conservator to establish conservation treatment(s) for object(s)
 - arrange for packing and shipping of objects to park
 - work with conservator and park curator to determine object rotation schedule
- work with maintenance and engineering staff to address
 - preservation requirements, including minimizing exposure to damaging UV, visible light, and humidity fluctuations
 - accessibility requirements
 - energy efficiency
 - health and safety code considerations
 - visitor flow
 - safety requirements
 - emergency preparedness issues

3. *What steps are involved in historic furnishings installations?*

The ultimate goal of any furnishings project is the installation of objects to create an authentic furnished historic exhibit. Objects have to be installed carefully and securely to ensure an accurate historical scene. Good organization helps facilitate an installation. The project curator needs to take the steps noted below.

- arrange for painting, wallpaper hanging, and the laying of carpet or other wall, floor and window coverings in advance of the rest of an installation
- pack objects that are being shipped to the park according to their location in a furnished exhibit to minimize handling. Pack objects made of similar materials together to avoid potential damage, such as ceramic plates placed under cast iron skillets.
- select alternative objects or reproductions to be used to rotate and ‘rest’ objects on exhibit to ensure longevity
- post inventories of box contents inside and outside the box to ensure minimum handling
- unpack and examine objects
- work with the park curator to accession and catalog newly acquired objects and, as needed, prepare catalog records for public posting on the *Web Catalog*
- place objects in their proper locations within the historic structure
- retain packing materials until all objects are accounted for
- make sure staff is equipped to install objects
- install, together with a mount maker or conservator, fragile material on special mounts
- oversee installation of barriers and runners to help protect objects on exhibit
- ensure appropriate lighting of objects and spaces, including visible and ultra-violet filtering films or barriers on windows and light fixtures to minimize damage to objects
- work with park staff to develop complementary programs and media, including a virtual exhibit and house tour, and *Teaching with Museum Collections* lesson unit plan.

4. *Should I develop a “punch” list after the installation?*

Yes, definitely. You need to develop a punch list of any specifications that are outlined in the project agreement that have not been addressed. Provide the project curator, contractor or HFC with a copy of the list. Only sign off on the project agreement once these have been corrected to your satisfaction. Refer to Chapter 7, Section F, Producing and Installing Exhibits for additional information.

5. *How do I correct factual errors after installation?*

Document all the factual errors that occur in the interpretive label copy and signage. Similarly, document any problems in the actual installations. Notify the superintendent of these errors, and send a copy to the attention of the historic furnishings report [HFR] author and/or the HFC Department of Planning and Research for correction. Have these errors corrected within a specified time and require that revised label copy and signage are

provided to the park. Include a copy of the memo in the report.

F. Preservation and Maintenance

1. *What object preservation issues must I consider when furnishing historic interiors?*

Historic furnished interiors demand the harmonious balance of the competing needs of visitor access, preservation of collections, interiors, and the structure itself. The display of collections in the open, for extended periods of time, and in uncontrolled conditions, present particular management challenges.

Typically fragile objects on exhibit in historic furnished structures are made of, or decorated with natural materials. These are cotton, wool, silk, linen, paper, bone, ivory, wood, paint and varnish. Historic furnishings made of these materials include wallpaper, window coverings, furniture, especially upholstered pieces, and carpeting. These are particularly sensitive to light and humidity fluctuations. Materials less subject to deterioration are ceramics, glass, and metals. However, these materials will also degrade if exposed to poor environmental conditions.

The project curator works with the park curator and a conservator to determine which objects should be replicated and which objects should be rotated off display to ensure longevity. If an object is too fragile to withstand extended exhibit in a historic furnished structure, it should be represented by a reproduction or a period piece. The original, fragile items should be placed in storage. Refer to Chapter 7, Section H, Exhibit Conservation and Section I, Preserving and Protecting Objects in the Exhibit Process for information on preserving and protecting collections on exhibit.

2. *What preservation challenges do furnished historic interiors present?*

Preventive conservation in historic interiors presents many challenges. Open furnished interiors, rather than closed exhibit cases, can mean that the object's environment can't be readily controlled. Also, by only focusing on the structure's preservation needs, you may cause the object irreversible damage. Make sure that the HVAC, lighting, and object placement support rather than diminish the object's preservation. Close monitoring, UV, visible light, and humidity control, and systems adjustments are required. Use 'low tech' period appropriate practices such as drawing curtains, closing shutters, and installing dust covers on furnishings to protect furnishings. Design visitor flow to keep objects out of reach. Incorporate elements of good housekeeping procedures. These steps will prolong the life of your collections on exhibit in the historic furnished interior. Use these and other historically appropriate practices as an interpretive tool to explain NPS efforts to preserve museum collections. You could also have samples made expressly available for people to handle, so that they don't feel the need to touch the objects on display.

Refer to procedures outlined in Chapter 7, Using Museum Collections in Exhibits, in particular, Figure 7.4. Exhibit Conservation Checklist. *MH-I* has extensive guidance on all aspects of preservation and protection, including Chapter 4. Museum Collections Environment; Chapter 5, Biological Infestations; Chapter 9, Museum Collections Security and Fire Protection; Chapter 10, Museum Housekeeping. Also refer to *MH-I*, Appendix J, Curatorial Care of Paper Objects, Appendix K, Curatorial Care of Textile Objects; Appendix L, Curatorial Care of Paintings, Appendix N,

Curatorial Care of Wooden Objects; Appendix Q, Curatorial Care of Metal Objects; Appendix P, Curatorial Care of Ceramic, Glass, and Stone Objects; and Appendix R, Curatorial Care of Photographic Collections.

Refer to Chapter 6, Special Uses of Museum Collections for guidance related to protecting the interior during filming, still photography or other special uses. Make sure that a treated or conserved item, when it is returned to exhibit, is compatible with other objects on exhibit.

3. *How do I protect museum collections from light damage?*

Develop and implement a housekeeping plan that will protect collections on exhibit in historic furnished interiors. To protect and preserve objects on exhibit, be sure to:

- Place objects, particularly sensitive materials, such as lithographs, away from direct and indirect sunlight.
- Install period appropriate shutters, blinds, or curtains on windows.
- Keep lighting levels to a minimum. Draw blinds, curtains, and shutters to protect against light damage. A visitor's vision will adjust to lower light levels. Reduced light also keeps the spaces cool if there is no air conditioning, and helps to lower air conditioning electrical bills.
- Install UV blinds or filtering films on windows.
- Install and maintain UV absorbent sleeves on fluorescent lights.
- Keep objects away from heat sources, such as windows, spotlights, lamps radiators, and air vents.
- Turn lights off when rooms aren't in use.

4. *How do I protect museum collections from environmental damage?*

To minimize the adverse impact of relative humidity and temperature, and minimize pest infestations, you should:

- Develop a housekeeping plan that includes a rigorous IPM component.
- Monitor relative humidity and temperature; refer to Chapter 7, Section H, Conservation.
- Maintain a stable environment. Avoid peaks and valleys in relative humidity and temperature when the structure is opened and closed to visitors.
- Ensure adequate ventilation to avoid mold growth.
- Keep objects away from air vents, radiators, pipes and outdoor windows.
- Do not use fresh flowers or live plants in the interiors.
- Install and monitor pest traps throughout the interior.

5. *Can object placement*

Yes. Object placement can make an enormous difference to object

help protect objects on exhibit?

preservation and security. Always keep objects out of reach. The challenge is securing an artifact without noticeably compromising historical accuracy. For example, modern art hanging equipment can be used to hang paintings while hidden behind the painting. A period picture rope can be attached to the painting support. You can:

- Relocate objects as necessary to keep them completely out of the visitor's reach and pathway.
- Locate furniture, such as a bench, in front of paintings to provide an additional barrier.
- Place vulnerable, fragile, and light-sensitive objects in darker areas of the structure.
- Locate valuable, small or fragile objects, especially firearms, well behind visitor barriers or in appropriate cabinets. Use additional security methods (i.e., individual alarms, monofilament line, spot-check inventories) when appropriate. See MH-I, Chapter 9 and Appendix G for more information.
- Monitor wear and tear on walls, runners, and carpets, using modern (replaceable) reproductions where possible.
- Move furnishings as little as possible; always have 2 people move an item.
- Use carpet runners to protect original carpeting and floors.
- Use thick carpet paper under carpets and underlays to absorb moisture.
- Use padding (underlays) under carpets to protect against abrasion.
- Rest heavy items on caster cups to protect floors and rugs.
- Sit objects on soft fabric or chamois mats to prevent abrasion of surfaces, such as tables.
- Protect furnishing with appropriate period dust or slipcovers.
- Place fragile and valuable items in storage and replace with reproductions, similar sturdier items, or establish a rotating schedule to keep the items on exhibit for only short periods.

6. *What should I do about visitors and traffic flow?*

You should:

- Work closely with interpreters to have them explain to visitors that they, the visitors, play an important role in preserving museum collections by not handling or touching the objects on display. Interpreters should also inform visitors about damaging effects of light and heat, and the efforts that NPS makes to minimize these in the historic furnished structure.
- Have an adequate number of staff present when visitors are present.

- Place items out of visitors reach to avoid handling, wear and tear.
- Protect historic floors and floor coverings by using runners to control visitor foot traffic.
- Provide slip-resistant shoe covers or booties to visitors to avoid damage from high heels and other damaging footwear.
- Avoid hanging paintings and placing objects in confined areas such as staircases to minimize accidental damage. Keep runners and carpets clean to prevent abrasion damage to floors and covering from grit and dirt.
- Place a doormat, boot scrapers, and metal grids at the entrance to eliminate abrasive gravel and dirt before visitors enter the structure.
- Have a receptacle for umbrellas, bags and other items to minimize accidental damage.

7. *What safety and security precautions should I take?*

You should:

- Review and update Opening/Closing procedures, key control and fire prevention on a regular basis and train staff to be security conscious.
- Keep keys out of locks, control access to rooms, closets, cabinets and other unused spaces.
- Use stanchions and ropes where possible.
- Never use real candles or light a real fire in a furnished historic structure. Use electric reproduction 'candles' and burning coals. For more information see link: < <http://www.elcanco.com/>>.
- Use visually pleasing and period appropriate barriers to protect objects where appropriate.
- Use carpet runners to keep visitors on a directed path through the interior.
- Always provide accompanied guided tours of the interior or structure.
- Install individual alarms for vulnerable objects.
- Consider installation of recorded closed circuit television (CCTV) systems to enhance security of furnished historic structures.

8. *What do I need to know about structural preservation issues?*

As museum curator you're responsible for knowing about the museum collections. However, you should also have an understanding of the complexities of structural preservation issues. They have an impact not only on the historic structure and its interiors, but also on the museum collections they contain. Whenever possible, coordinate with architects and engineers in the regional office and DSC on the structural components, systems and architectural elements that impact the historic furnishings.

- Heating, ventilation, and air condition [HVAC]
- Lighting
- Security
- Accessibility
- Barriers

Manage historic structures housing museums collections in accordance with curatorial standards while meeting structural preservation needs. The needs of the collections should not compromise the structure itself, and the needs of the structure should not compromise the collections.

9. *What happens immediately after the project is installed?*

When all objects have been installed, the project curator:

- identifies unfinished tasks or problem areas for inclusion on a listing often referred to as a “punch list.”
- works with the contractor or HFC, Department of Planning and Research staff to ensure the punch list is compiled and problems are corrected before the park signs off on the contract.
- takes the park curatorial and interpretive staff through the completed exhibit
- provides a rationale of the treatment and interpretation presented by the furnished historic interior
- points out the significance of the new acquisitions
- explains the nuances and historical authenticity of the installation

This includes the display of a desk that has been furnished as untidy, if photographic evidence supports an untidy desk in historical use. Similarly, the placement of items such as military equipment makes sense when a project curator explains actual military usage.

10. *Should I monitor object condition?*

Yes. Monitor the condition of objects on display in the historic furnished structure with high resolution photographs (images) of each object on display, and detailed interior photographs. Develop and follow a written inventory and checklist and annotate conditions on a regular basis. Establish a monitoring survey routine, such as a daily and weekly survey. Check objects, their condition, and whether any damage has occurred by closely examining the objects, and by comparing to object photographs. If remedial action is necessary, discuss with a conservator and report the need to a supervisor. A survey should include recordings and evaluation of hygrothermograph or other data collector recordings.

11. *What do I need to know about housekeeping?*

Work with maintenance staff to develop and implement a housekeeping plan appropriate to the historic furnished interior or structure. Refer to *MH-I*, Chapter 5, Biological Infestations for information on IPM plans and

Chapter 13, Museum Housekeeping. Develop a checklist of housekeeping tasks that will take place on a daily, monthly, and quarterly basis. Set up a housekeeping schedule in accordance with the guidelines outlined in *MH-I*, Chapter 13, Museum Housekeeping. Consult with a professional conservator as you develop the plan.

Your housekeeping plan addresses environmental controls, dusting, pest monitoring. Include frequency of tasks, supplies and equipment, and vendor sources to be used or not used, and techniques of housekeeping. Conservators trained in the care of historical objects can prescribe methods of cleaning. Arrange to rotate fragile objects, such as textiles, seasonally to help ensure their long-term preservation. Parks should include a strategy to rotate objects on exhibit in the furnished historic interior. If an object is rare or fragile, keep it in storage, and use a reproduction or period piece in the furnished interior instead. If a scholar wants to see an original object, he or she can arrange with a site curator to examine it.

Regular and thorough housekeeping and routine maintenance is your best preventive conservation strategy.

12. *What opening and closing procedures do I need to implement?*

To ensure security, implement procedures outlined in *Museum Handbook*, Part I, Appendix G, Figure G.3, Sample Furnished Historic Structure Opening and Closing Procedures.

G. Documenting Historic Furnishings on Exhibit

All objects on exhibit in the furnished historic interior must be documented. This includes accessioning and cataloging, and gathering information from primary sources such as documents, photographs, oral history transcriptions, or other material evidence. Some of these primary documents may themselves be on exhibit. Secondary documentation includes books, periodicals and unpublished accounts that provide information on the furnishings and the individual, structure, and period of the site. The project curator uses primary, secondary sources, and other relevant materials to prepare a historic furnishings report. The park and regional office review the report. Historic structures should be documented in conformance with *The Secretary of the Interior's Standards for the Treatment of Historic Properties with Guidelines for the Treatment of Historic Furnished Interiors*. See <http://crm.cr.nps.gov/archive/24-07/24-07-10.pdf>. and < <http://www.cr.nps.gov/hps/tps/standguide/>>.

Original documentation and research information allows you to make informed management decisions about the collections and the interior. These data enable you to provide appropriate care once the interior has been furnished.

1. *Should objects in the furnished historic interior be cataloged?*

Yes. Objects on exhibit in a furnished historic structure must be accessioned and cataloged in accordance with procedures outlined in *MH II*, Chapter 2, Accessioning and Chapter 3, Cataloging. For additional information on documenting objects on exhibit, refer to Chapter 7, Section M, Documenting Collections on Exhibit. As appropriate, the objects should be posted to the *Web Catalog* at <http://www.museum.nps.gov> to complement the exhibit.

2. *When should I arrange for illustrations for artwork?* The park may need illustrations for a historic furnishing report or display in the furnished historic interior. The project curator can contract directly with an illustrator to produce prospective drawings or work with HFC staff. Samples of drawings may be requested from the HFC, Department of Planning and Research. These drawings should be included in the report.
3. *What documentation do I need for objects undergoing conservation treatment?* File copies of object treatment requests and reports, and other documentation for objects receiving conservation treatment in the accession folder. The conservator, whether a contractor, center or HFC staff, must provide the park with object treatment report and copies of all documentation and photographs. Include this requirement in the project agreement. Direct conservation treatment questions to the HFC Department of Artifact Conservation manager.
4. *When should I borrow objects for installation?* The park must make every effort to use and acquire park museum collections for historic furnished structures. However, on *very rare* occasions, a park may need to borrow objects for an installation of a furnished historic structure. *Note:* A park should consider borrowing only if an on object is absolutely critical to a furnishings exhibit. For detailed information on NPS incoming loan procedures, refer to *MH-II*, Chapter 2, Accessioning. The park should make an effort to permanently acquire such material.
5. *When do I need to insure objects?* The park may be required to insure borrowed objects. Refer to *MH-II*, Chapter 4, Section VII, Purchasing Insurance for Borrowed Objects for detailed information on acquiring insurance.
6. *Do I need to annually inventory items on exhibit in the furnished historic interior?* Yes. You need to inventory museum collections on exhibit in the furnished historic interior in accordance with guidelines in *MHIII*, Chapter 4, Inventory and Other Special Instructions.
7. *What do I need to know about acquiring images?* Paintings, photographs, drawings and documents are often used in furnished historic interiors. Refer to Chapter 4, Two Dimensional Reproductions for information on how to obtain copies of images. For information on copyright, privacy and publicity issues, refer to Chapter 2, Legal Issues. These chapters provide detailed guidance on how to obtain written permission and rights to use images in an exhibit. The park can expect to pay a fee for the use of an image. Refer to Chapter 1, Sections D and E for information on dealing with restricted or sensitive materials. For additional information, contact the regional curator, Museum Management Program or the HFC, Department of Knowledge Archives unit.
8. *What photographs do I need?* You should have high quality photographs and/or high resolution digital images of all objects, including digital and film-based images that go on exhibit in a furnished historic interior. Once the furnished historic structure is installed, arrange for professional photographs of the installation. These photographs serve several purposes. Photographs provide an object and room inventory, refer to Chapter 7, Section M, Documenting Objects on Exhibit. They provide documentation and accountability for collections security as well as baseline information that will assist the park curator in monitoring object condition. Historic furnishings tend to be dynamic. Over a period of time, they can be moved, changed, rearranged, removed and added back to the historic structure. Installation photography documents how the exhibit should look in the event items are inadvertently moved after

the exhibit is installed.

Use the digital images to develop a virtual web exhibit and tour of the furnished interior and the structure. They can be multi-purposed into brochures and catalogs, and used to publicize the exhibition. The images should augment the catalog record in ANCS+.

9. *How do I handle public requests to photograph the historic furnishings installation or the objects?*

Many public and private museums permit the photography of objects on exhibit. Some museums prohibit any photography, and others prohibit flash photography for several reasons. Excessive exposure to flash light may threaten sensitive objects. The taking of photographs with flash can be distracting to visitors. In the past, flash bulbs occasionally exploded, posing a risk to objects. Today, most flash units are built into cameras, so the threat of explosion is unlikely. Some museums seek to control access to images of their collections by prohibiting photography or only allowing it by special permit.

A park should decide whether to allow photography in exhibit areas and if so, under what conditions, and may limit flash photography. Refer to Chapter 6, Section D. Filming and Photography in Spaces Housing Museum Collections for additional information.

H. Interpreting Furnished Historic Interiors

1. *Why are furnished historic interiors used to interpret park resources?*

Historic furnished interiors evoke a powerful interpretive experience for visitors who sense that "history actually happened here." Historic furnishings allow parks to provide authentic interiors that commemorate the men and women, major events, and daily life that are celebrated in the national park system. They provide a direct link to an individual, event or period. Historic furnishings are situated in historic structures where significant events took place. They help recapture past eras and create moods using original and reproduction furnishings. Unlike a traditional museum exhibit in a gallery or visitor center, the furnished interior provides the original context where a particular person or group of people lived or worked, or where the event or process took place. Furnishings present an intimate look at the homes, places of work, belongings, and lives of presidents, pioneers, immigrants, artists and authors. On entering historic furnished spaces, visitors become witnesses to history. Furnished historic interiors make history real and immediate.

Define the goal or theme and sub-themes of the furnishings project at the project outset. This will ensure that the park achieves its stated interpretation goals.

2. *What is the Comprehensive Interpretative Plan?*

A park develops a Comprehensive Interpretive Plan (CIP) to outline its interpretive goals and how it will achieve them. The park's CIP describes the role of historic furnishings to the site. Furnishings allow the park to more fully interpret persons, events, and lifestyles. Individual historical objects in parks may represent prime examples of American decorative arts. However, they are in the furnished historic structure exhibit to tell a story about the persons and events that are being celebrated at the park. The furnished interior is intended to allow the visitor to feel as though they are

stepping into history. The chief of interpretation should focus training for staff and volunteers on how furnishings reflect a park's goals as described in its CIP.

3. *What types of interpretation do historic furnished interiors provide?*

Historic furnished interiors can:

- Preserve objects directly associated with the place, event or individual being commemorated. Such objects are considered 'original to the site.' The objects are preserved in their original setting. Examples include the home of Franklin Delano Roosevelt, Hubbell Trading Post, and the machine shop at Edison NHS.
- Recreate the scenes of specific historic events. Examples include Independence Hall at Independence NHP, the McLean House at Appomattox Courthouse NHS, and the bedroom in the House Where Lincoln Died at Ford's Theatre NHS.
- Create period settings for objects original to the site. An example includes the Russian Bishop's House at Sitka NHS.
- Create period settings to enhance interpretation. Examples include the clothing store at Harpers Ferry NHP and the commanding officers quarters at Fort Larned NHS or the Cast House at Hopewell Furnace NHS.
- Create period settings for adaptive use using reproduction objects exclusively. Examples include a room at Lemon House, Allegheny Portage NHS

The furnishings in a historic interior create an immediate context. The objects and their setting should be used to expand the visitor's understanding and appreciation of the time and society in which they were created and used. Many objects actually belonged to and were used by individuals that the site is celebrating. The objects make a powerful connection to those individuals and their times. The interpreter can enliven the visit by weaving engaging information about the people, events and their belongings into the tour. They can ask relatively simple questions, such as "have you any idea what this was used for?" or "how was this item made?" These questions engage the visitor and focus their attention of the historic objects they are seeing. They can use the objects to tell the visitor about family life, social activities, food preparation and preservation, and customs of the period. Information about decorative arts, furniture and art styles, and other materials can be made fascinating to visitors.

A binder with expanded catalog cards and photographs can be extremely useful to interpreters. Well-designed audio tours accommodate extensive information that is user-activated.

4. *What time period is interpreted in the furnished historic interior?*

Furnishings interpret a particular point or points in time. A site can interpret a particular story, individual, or era. It can also interpret several decades or centuries of occupation within a single structure. Historic furnishings can tell the story of adaptive use over generations. In addition to interpreting specific individuals, events or periods, historic furnishings can be used to explain the process of interpretation itself.

5. *What are some of the methods of interpreting historic furnishings?*

To enhance the visitor experience and provide a learning opportunity, the historic furnished interior needs interpretation. There are several different methods of interpretation, and one or more may be used at a site. They include a:

- guided tour conducted by a trained interpreter
- predefined, self-guided tour using an audio guide
- self-guided tour through the structure with written interpretive label copy placed at selected points throughout the structure. The reading of labels is optional.

For additional information on interpretation, refer to DO #6, Interpretation and Education, documents outlined in Section B.2. of this chapter, and Chapter 7, Using Museum Collections in Exhibits.

6. *How can the project curator assist with interpretation of the historic furnishings?*

Once all objects are installed, the project curator should walk the site interpretive staff through the completed exhibit. The guided tour includes an explanation of the furnishings, new acquisitions, and how they relate to the installation. This preliminary staff tour must include the special preservation, security and fire prevention needs of the new furnishings exhibit. The interpretive staff will also need the “who, what, where, when and how” to find out additional information on the collections in order to improve their tours and to answer visitors questions. The project curator should explain why certain furnishings have been included, and why they have been arranged in a certain way. For example, that a desk has been furnished to appear untidy, since photographic evidence showed that desk was untidy in its original, historical use. Similarly, the rationale for the placement of military equipment might become clearer to interpreters when a furnishings curator explains contemporary military usage. The project curator provides binders containing hardcopy information, photographs, and other research materials related to the HFR for use by interpretive staff.

7. *Who is involved in interpreting the historic furnishings installation?*

A park is responsible for maintaining a furnished historic structure exhibit and for interpreting it to its visitors. It fulfills these tasks through its staff and volunteers. Depending on the size of a park, the following offices play a key role in the preservation and interpretation of historic furnishings: curation, security, maintenance and interpretation. Park chiefs of security, maintenance, cultural resources and interpretation must coordinate their responsibilities in these areas and corresponding staff and volunteers must do the same.

8. *How does the park answer inquiries from staff, visitors and the public?*

The park receives a complete research file from the project curator covering the entire project. This includes photographs, interviews and other materials. This file is a resource for answering questions. Make copies of the information on each artifact to place in individual catalog or accession folders. Develop a reference file of furnishings that contain photographs and well-documented catalog information for easy retrieval and use by park interpreters.

I. Evaluating Historic Furnishings

1. *How do I evaluate the historic furnishings installation?*

As applied to a furnished historic structure exhibit, you may evaluate the success of the exhibit against several standards. These are organized into the following time segments;

- preliminary
- planning and production
- post-production

2. *What is preliminary evaluation?*

Preliminary evaluation occurs during general management planning when planners decide whether the use of a furnished historic structure is an interpretive option. Their decision must be weighed against the standard set by Management Policies for the National Park Service, quoted here in its entirety:

When the historic furnishings of a structure are present in their original arrangement in a historic structure, every effort will be made to preserve them as an entity. Such historic furnishings will not be moved or replaced unless required for their protection or repair, or unless the structure is designated for another use in an approved planning document. The original arrangement of historic furnishings will be properly documented. A structure may be refurnished in whole or in part if

- *All changes after the proposed refurnishing period have been professionally evaluated, and their significance has been fully considered*
- *A planning process has demonstrated that refurnishing is essential to public understanding of the park's cultural associations; and*
- *Sufficient evidence of the design and placement of the structure's furnishings exists to enable its accurate refurnishing without reliance on evidence from comparable structures.*

NPS Management Policies, Chapter 5.3.5.5.5., Historic Furnishings, 2006

Whether a site uses historic furnishings must be judged on the criteria cited above. The direct relation of furnishings to a primary park theme should be apparent to the members of the general management planning team. A formal value analysis provides the best way of deciding whether historic furnishings is the best way of interpreting history to the public. Such an analysis should be done even if the potential budget for historic furnishings is less than \$500,000, the threshold at which formal value analysis must occur. In accordance with the NPS Value Analysis Manual, value analysis is “the systematic application of recognized techniques by multi-disciplined teams who identify the function of a product or service, establish a worth for that function, and provide alternate ways to accomplish the necessary function reliably, and at the overall lowest cost, through creative

techniques.” In order to determine whether sufficient evidence exists to furnish with minimal conjecture, the historic furnishings curator evaluates the quality of resources; documents, photographs and collections, in consultation with park staff.

3. *What is planning and production evaluation?*

Evaluation of the historic furnishings process during the planning and production stages comes from two different perspectives: timeliness and accuracy. Timeliness can be measured against a formal performance agreement negotiated in advance of any planning or production. Whether a project is “on time” can be judged by whether the element agreed to has been completed or an extension of a deadline has been negotiated. A park superintendent or the appropriate HFC staff must judge the accuracy of the work being done.

4. *What is post-production evaluation?*

A post-production evaluation of a furnished historic structure project can be accomplished from three perspectives: efficiency, effectiveness and durability.

- *Efficiency* refers to whether the project has been completed according to a project agreement. The HFC, Department of Planning and Research agreed to plan and produce an accurate furnished historic exhibit according to a set schedule. Whether it did so is a measure of the efficiency of planning and production
- *Effectiveness* refers to how successful the exhibit is as an interpretive media. It is a measure of Management Policies, the extent to which historic furnishings are the best way of interpreting a history to the public. Effectiveness is more difficult to measure than efficiency. The park should do a formal visitor analysis to determine effectiveness. The park should contact the regional curator, HFC, Department of Planning and Research or the NPS Cooperative Park Studies Unit (CPSU) at the University of Idaho about doing a formal evaluation. Specialists at the CPSU can develop and administer a survey of the effectiveness of historic furnishings. The evaluation should be consistent with the Servicewide Interpretation and Education Evaluation Strategy (2006). The survey can point out strengths and potential weaknesses of the furnished structure exhibit. Weaknesses can be identified, examined, worked on, and corrected.
- *Durability* or how well objects withstand exhibition. The parts of the furnished historic exhibit that receive the most wear are floors, and walls and woodwork that are within visitor reach. These areas should be furnished with reproductions and protected with barriers. A furnishings project should include sufficient funding for buying extra carpeting and wallpaper to replace carpeting and wallpaper lost to wear by visitors or damaged by maintenance activities. Give interpreters instruction on how to minimize visitor impacts, including handling and leaning against structural elements such as walls.

Objects made of organic materials are particularly sensitive to adverse environmental conditions. The furnishings plan should provide rotation plan for sensitive objects, minimize the effects of deterioration and provide reproduction items for the installation. A major source of potential damage is light, so every effort must be made to keep organic materials away from light sources. Keep humidity stable.

J. Rehabilitating Historic Furnishings Installations

1. *What should I do when objects show signs of wear?*

Rehabilitating a historic furnished exhibit can occur when objects are worn, torn or faded, or when new evidence surfaces to support exhibit rehabilitation. For deteriorated objects, a park should contact the HFC, Department of Planning and Research to help determine what might be done to replace deteriorated objects with reproductions. For original objects that have deteriorated, obtain the services of a conservator, or contact the associate manager for Historic Furnishings who can confer with the associate manager for Conservation on how to proceed.

2. *How do I update the historic furnishings installation?*

A well-documented historic furnishings report should need not to be revised. Good documentation should support a plan in perpetuity. Occasionally, though, a site will find new evidence on original furnishings or new research may uncover errors in the previous HFR. The evidence may be in the form of documents, photographs or original objects. A park may have the opportunity to acquire an object having primary association to its collections. When any of these situations occur, a park can contact the associate manager for Historic Furnishings at Harpers Ferry Center. The new evidence may warrant a revision or an amendment to a furnishing plan, or it may even warrant an entirely new historic furnishings report.

K. Selected Bibliography

Alderson, William T. and Shirley Payne Low. *Interpretation of Historic Sites*. American Association for State and Local History. Nashville. 1985.

Butcher-Youngmans, Sherry. *Historic House Museums: A Practical Handbook for Their Care, Preservation, and Management*. Oxford University Press. 1996.

Chitty, Gill and David Baker, editors. *Managing Historic Sites and Buildings: Reconciling Presentation and Preservation*. Issues in Heritage Management Series, Routledge, London, 1999.

Curling, Marianne. Technical Leaflet, # 218, "How to Write A Furnishing Plan." Included in *History News*, Volume 57, Number 2, Spring AASLH, Nashville, TN. 2002.

Donnelly, Jessica Foy, editor. *Interpreting Historic House Museums*. AltaMira Press, Walnut Creek, CA. 2002.

Farvetti, Rudy J. and Joy Putnam Farvetti. Revised 2nd Edition. *Landscapes and Gardens for Historic Buildings*. AASLH, Nashville, TN. 1991.

Fisher, Charles E. and Hugh C. Miller, editors. *Caring for Your Historic House*. Harry N. Abrams. New York, NY. 1998.

Heaver, Melissa M. *Housekeeping for Historic Homes and House Museums*. National Trust for Historic Preservation, 2000.

Howe, Barbara J. and Dolores A. Fleming, Emory J. Kemp, and Ruth Overbeck. *Houses and Homes: Exploring their History*. American Association for State and Local History, Nashville, TN. 1987.

Lewis, Ralph. *Manual for Museums*, U. S. Department of the Interior, National Park Service. Washington, DC. 1976.

Chapter 6. Furnished Historic Structure Museums at
http://www.cr.nps.gov/history/online_books/curatorship/pdf/6.pdf

McGiffin, Robert F. *Furniture Care and Conservation*, Revised 3rd Edition. AASLH, Nashville, TN. 1987.

National Park Service.

Museum Handbook, Parts I-III.
<http://www.cr.nps.gov/museum/publications/index.htm>

Guidelines for Preparing Historic Furnishings Reports. <http://www.nps.gov/hfc/products/furnish/furnish-plan-hfr-guide.htm>

Planning a Historic Furnishings Report. <http://www.nps.gov/hfc/products/furnish/furnish-plan-hfr.htm>

Implementing a Furnishings Report. <http://www.nps.gov/hfc/products/furnish/furnish-object-hfr.htm>

Guidelines for Preparing Historic Furnishings Reports. <http://www.nps.gov/hfc/products/furnish/furnish-plan-hfr-guide.htm>

Historic Furnishings Report. Kelso Depot: A Furnishings History and Recommended Plan. Mojave National Preserve. http://www.cr.nps.gov/history/online_books/kelso/index.htm

National Park Service Northeast Region's *Guidelines for the Treatment of Historic Furnished Interiors in Accordance with The Secretary of the Interior's Standards for the Treatment of Historic Properties*, Northeast Museum Services Center, NPS, with Mid-Atlantic Association of Museums, New York State Office of Parks, Recreation, and Historic Preservation, Pennsylvania Historical and Museums Commission, 2006.

http://www.google.com/custom?q=National+Park+Service+Northeast+Region%E2%80%99s+Guidelines+for+the+Treatment+of+Historic+Furnished+Interiors+&sa=Search&client=pub-1415334591037307&forid=1&ie=ISO-8859-1&oe=ISO-8859-1&cof=GALT%3A%230000FF%3BGL%3A1%3BDIV%3A%23FF0000%3BVLC%3A333333%3BAH%3Acenter%3BBGC%3AFFFFF%3BLGC%3AFFFFF%3BALC%3A0000FF%3BLC%3A0000FF%3BT%3A000000%3BGFNT%3A333333%3BGIMP%3A333333%3BLH%3A39%3BLW%3A100%3BL%3Ahttp%3A%2F%2Fwww.mercuras.com%2Frefdesk_logo_search_LP_v3.gif%3BS%3Ahttp%3A%2F%2Fwww.refdesk.com%3BLP%3A1%3BFORID%3A1%3B&hl=en

Department of the Interior. *The Secretary of the Interior's Standards for the Treatment of Historic properties* (1995). Codified as 36 CFR 68.

Nylander, Richard. *Wallpapers for Historic Buildings: A Guide to Selecting Reproduction Wallpapers*

Nylander, Jane. *Fabrics for Historic Buildings: A Guide to Selecting Reproduction Fabrics*

The National Trust Manual of Housekeeping: The Care of Collections in Historic Houses Open to the Public. Butterworth-Heinemann in association with the National Trust, United Kingdom, 2006..

Seale, William. *Recreating the Historic House Interior*. American Association for State and Local History. Nashville, TN. 1979.

Suits, Linda N. Technical Insert, "Here I have Lived: The Preparation and Implementation of a Historic Furnishings Report." *Illinois Heritage Association, Sept.-Oct. 2000*

Tinniswood, Adrian. *A History of Country House Visiting: Five Centuries of Tourism and Taste*. Basil Blackwell and the National Trust, United Kingdom. 1989.

Sherry Butcher-Youngmans. *Historic House Museums: A Practical Handbook for Their Care, Preservation, and Management*. Oxford University Press. 1996.

Patricia West. *Domesticating History: The Political Origins of America's House Museums*. Smithsonian Institution Press, Washington, DC, 1999.

Von Rosenstiel, Helene and Gail C. Winkler. *Floor Coverings for Historic Buildings: A Guide to Selecting Reproductions*

L. List of Figures

Figure 8.1. Checklist for Exhibit Museum Collections in a Furnished Historic Interior

Figure 8.2. Checklist for Preventive Object Conservation in a Furnished Historic Interior

Figure 8.3. Sample Agreement between Harpers Ferry Center, Department of Planning and Research and a Park

Figure 8.4. Annotated Guidelines for Preparing Historic Furnishings Reports prepared by HFC, Department of Planning and Research

Figure 8.5. Determining the Cost of Furnishing Historic Interiors Based on a HFC, Department of Planning and Research Document

Figure 8.6 Outline of Recommended Practices for Historical Furnished Interiors Adapted from “Standards for Preservation & Guidelines for Preserving Historic Furnished Interiors” of the NPS Northeast Region’s Guidelines

Figure 8.1: Checklist for Exhibiting Museum Collections in a Furnished Historic Interior

Activity	Action and Date
Initial Planning	
Statement of Purpose	
Period[s] identified	
Individual or group identified	
Event[s] identified	
Process[es] identified	
Develop schedule	
Develop budget	
Objects	
Review accession and catalog folders	
List potential objects for inclusion	
Identify objects for display	
Ensure selected objects are cataloged	
Obtain object record photographs	
Provide detailed object condition descriptions	
Identify sensitive items	
Identify items needed on loan	
Complete loan agreements	
Obtain insurance as needed	
Identify alternate items for exhibit rotation	
Reproduction Allow enough time and resources to safely replicate exhibit objects. Arrange for reproduction of 3-D objects such as furnishings Arrange for copying of 2-D materials such as photographs	

Documentation	
Create a folder to house documents such as:	
Room inventory	
Installation photographs	
Listing of objects	
Rights Acquisition	
Check accession or catalog folder to see if NPS has rights to images, photographs and artwork	
Verify transfer of copyright on accession [gift] form(s)	
Include statement on incoming loan agreement granting NPS right to exhibit item	
Obtain rights to use non-NPS images and illustrations	
Obtain written permission and file in exhibit folder	
<p>Conservation Treatment</p> <p>Determine conservation and preservation needs in consultation with a conservator</p> <p>Identify objects for rotation</p> <p>Obtain the following:</p> <p>Object Condition Report</p> <p>Object Examination Report</p> <p>Object Treatment Proposal</p> <p>Object Treatment Report</p> <p>Incorporate condition and treatment information in ANCS+</p>	
Research	
Obtain background information	
Historic Furnishings Report	
Prepare plan	
Review plan and incorporate edits	
Review plan and ensure conservation needs are addressed for collections that will go on exhibit.	
Work with exhibit curator to ensure concerns are addressed	
Graphics	

Illustrations	
Maps	
Multi-media	
Fabrication	
Electrical fixtures	
Fabric/textiles	
Photographs <ul style="list-style-type: none"> - black and white - sepia - color 	
Framing and matting	
Installation <p>Protect objects from excessive UV exposure</p> <p>Keep objects away from air vents, ducts etc.</p> <p>Cover windows with UV blinds, curtains or other appropriate media to block UV rays</p> <p>Work with preparator and conservator to install the furnishings</p>	
Accession and catalog new acquisitions to the collection. <p>Change object status and location in ANCS+</p>	
Develop MHP and IPM monitoring schedule	
Prepare punch list of problems to be corrected	
Correct problems	
Maintenance	
Obtain a maintenance manual	
Develop maintenance schedule	
Ensure access for cleaning, lighting, object rotation and emergencies	
Implement housekeeping and monitoring schedule	
Public Outreach	
Provide park interpretive and museum staff with installation information	

Prepare and disseminate a news release	
Develop a brochure or catalog	
Organize an opening	
Do community outreach	
Develop school program and kits	
Train volunteers and student interns	
Create virtual exhibit and tour	
Objects Preservation	
Conservation Treatments	
Reproduction	

Figure 8.2. Checklist for Preventive Conservation in Furnished Historic Interiors

Adapted from HFC, Conservation Department. Use this list in conjunction with Figure 7.4

Action	Comment/date
<ul style="list-style-type: none"> <input type="checkbox"/> Allow sufficient room for traffic flow. <input type="checkbox"/> Group objects with similar conservation needs <input type="checkbox"/> Plan to rotate objects on exhibit. <input type="checkbox"/> Select objects for rotation <input type="checkbox"/> Develop schedule for rotation <input type="checkbox"/> Block UV by: <ul style="list-style-type: none"> <input type="checkbox"/> Curtains <input type="checkbox"/> Blinds <input type="checkbox"/> Shutters <input type="checkbox"/> UV screens, films, Plexiglas/Lexan 	
<p>Temperature and Relative Humidity</p> <ul style="list-style-type: none"> <input type="checkbox"/> Obtain baseline information about the temperature and relative humidity. Interior/exterior of spaces [annotate] <input type="checkbox"/> Analyze the data. Take corrective actions as required. <input type="checkbox"/> Control the environment within the entire interior. <input type="checkbox"/> Place sensitive objects in the most stable locations, away from windows, HVAC vents, vibrations, visitors reach, and other potentially damaging impacts. 	
<p>Particulate Contamination</p> <ul style="list-style-type: none"> <input type="checkbox"/> Monitor pollutants <input type="checkbox"/> Use high-efficiency filters in environmental systems. <input type="checkbox"/> Use high-efficiency particulate (HEPA) filters in vacuums. <input type="checkbox"/> Use localized filtration equipment as needed. <input type="checkbox"/> Use door mats, boot/shoe scrapers, booties, runners and dust covers to protect collections. <input type="checkbox"/> Install/maintain and repair weather-stripping, storm-windows and caulk as historically appropriate 	
<p>Chemical Pollutants</p> <ul style="list-style-type: none"> <input type="checkbox"/> Monitor pollutants. <input type="checkbox"/> Incorporate chemical filters in the environmental systems. <input type="checkbox"/> Provide air circulation. <input type="checkbox"/> Select stable construction materials. <input type="checkbox"/> Aerate the interior space before object installation 	
<p>Lighting</p> <ul style="list-style-type: none"> <input type="checkbox"/> Develop a lighting plan that responds to conservation criteria. <input type="checkbox"/> Limit total light exposure. <input type="checkbox"/> Filter all sources of ultraviolet (UV) radiation. <input type="checkbox"/> Control infrared radiation (visible light). <input type="checkbox"/> Exclude sunlight. 	
<p>Biological Infestation</p> <ul style="list-style-type: none"> <input type="checkbox"/> Complete and implement an IPM Plan 	

<ul style="list-style-type: none"> <input type="checkbox"/> Examine objects for signs of infestation and active mold. <input type="checkbox"/> Avoid introducing insects through props and unchecked exhibit materials. <input type="checkbox"/> Control human behaviors that encourage infestation. <input type="checkbox"/> Keep clean, and , vacuum, dust and inspect items frequently. 	
<p>Physical Security</p> <ul style="list-style-type: none"> <input type="checkbox"/> Conduct a risk assessment. <input type="checkbox"/> Provide the appropriate level of protection. <input type="checkbox"/> Install individual alarms, monofilament, etc <input type="checkbox"/> Use appropriate barriers to protect collections. <input type="checkbox"/> Devise visitor routes to limit direct access to the objects. <input type="checkbox"/> Review and update Opening/Closing procedures <input type="checkbox"/> Lock doors to closets, cabinets, unfurnished rooms to prevent unauthorized access <input type="checkbox"/> Follow good key control procedures <input type="checkbox"/> Place firearms, weapons and other high value items away from easy reach and use additional security measures to prevent their unauthorized removal or theft. Use reproductions when necessary. <input type="checkbox"/> Provide guided tours of interiors 	
<p>Emergency Preparedness and Fire Protection</p> <ul style="list-style-type: none"> <input type="checkbox"/> Develop fire protection and emergency response plans. <input type="checkbox"/> Perform a risk assessment and address potential problems. 	
<p>Humidity-Control</p> <ul style="list-style-type: none"> <input type="checkbox"/> Ensure adequate air circulation. <input type="checkbox"/> Provide appropriate access to controls. <input type="checkbox"/> Select an appropriate passive or mechanical system. <input type="checkbox"/> Provide safeguards for mechanical systems. <input type="checkbox"/> Ensure that water pipes/installations aren't installed over historic furnishings. 	
<p>Choosing Conservation-Appropriate Materials</p> <ul style="list-style-type: none"> <input type="checkbox"/> Avoid adhesives within the object display area. <input type="checkbox"/> Review the composition of commercial interior finishes. <input type="checkbox"/> Isolate objects from painted or varnished surfaces. <input type="checkbox"/> Use the least hazardous material available, and isolate objects from them. <input type="checkbox"/> Isolate objects from problematic surfaces. <input type="checkbox"/> View the HFC "Exhibit Conservation Guidelines" CD 	
<p>Furnishings Installation</p> <ul style="list-style-type: none"> <input type="checkbox"/> Support all parts independently over as large an area as possible. <input type="checkbox"/> Stabilize objects from vibration. <input type="checkbox"/> Ensure the security of framed works. Avoid transporting objects into production areas. <input type="checkbox"/> Inspect exhibit assemblages that affect objects during the production phase. <input type="checkbox"/> Install archival barriers (Mylar, A/F paper, Volara foam, unbleached, washed Muslin, etc.) between objects and 	

furniture to prevent scratches, abrasion and wear	
<p>Maintenance</p> <p>Provide a maintenance manual that includes the conservation criteria.</p> <ul style="list-style-type: none"> <input type="checkbox"/> Monitor and evaluate temperature and relative humidity. <input type="checkbox"/> Perform necessary maintenance to ensure continued high performance. <input type="checkbox"/> Keep the exhibit area clean. <input type="checkbox"/> Plan ahead for the safe movement of objects. 	

Figure 8.3. Sample Agreement between Harpers Ferry Center, Department of Planning and Research and a Park

Overview of the Agreement

The Project Agreement consolidates primary information and agreements related to a project. By providing team members and managers with clear information on the scope of the project, team members' roles, the proposed work plan, the budget, and the schedule, the project can proceed in a coordinated, effective way.

Project Description

The Harpers Ferry Center, Department of Planning and Research will provide the Park with a historic furnishings report [HFR] for five historically furnished rooms; recommendations for furnishings, textiles, and wall coverings for a conference area room; and recommendations for moveable furnishings in four outdoor areas located at the Park.

Project Background

The Park acquired the estate adjoining the park boundary in 1963. The building houses the park conference center. At that time, the Park undertook extensive and not altogether sympathetic renovations of the property, removing much original fabric and disposing of many of the original furnishings.

More recently, however, the Park has redefined the use of space at the estate. A preliminary historic structure report [HSR] was completed in 1979, followed by a final historic structure report, historic landscape report and management plan in 1980. A master facilities plan completed in 1995 by a commercial group “seeks to combine interpretive, educational, conference and staff functions in harmony. The scope of work for the furnishings plan outlines the intended use of the structure. It states:

The first floor rooms will receive restoration-quality furnishings, and serve as interpretive spaces, like a house museum. The second and third floors are used primarily for conference guests, and need to be furnished in a complementary style to the historic surroundings, while offering appropriate support for participants' needs.

The Historic Preservation Training Center and Denver Service Center are handling the architectural planning, design, and construction for the restoration of the building. The Park Service's Buildings Conservation Center in Lowell, MA will do the paint analysis and contract for the restoration and recreation of the wall finishes in the historically furnished rooms. The HFC, Department of Planning and Research, as outlined in this project agreement, will provide documentation and recommendations for the historically furnished rooms, conference room, and adjacent four outdoor spaces.

Project Team

Team Member	Title	Project Role
Name	Staff Curator HFC, Dept. of Planning and Research Tel: Fax: e-mail:	Will serve as project manger and historic furnishings curator. Will conduct research, compile evidence, and make recommendations for furnishings in historically furnished rooms, conference areas, and four specified outdoor areas. Will coordinate between all team members. Will provide cost estimates for implementing Historic Furnishings Plan [HFP].
Name	Editorial Assistant HFC, Dept. of Planning and	Will edit HFR, arrange for reproduction of drafts, make corrections, and arrange for the production of

	Research Tel: Fax: e-mail:	the final report.
Name	Historian Park Tel: Fax: E-mail	Will serve as liaison between furnishings planner and Park. Will consult with furnishings planner on amount of research required and will provide input on selection of furnishings.
Name	Park Curator Park Tel: Fax: E-mail	Will consult with the historian and project curator on amount of research required and will assist in selecting furnishings from the museum collection. Will provide access to objects and information about collection identification.
Name	Administrative Assistant Park Tel: E-mail:	Will provide input on furnishings needs and use of space by conference participants.
Name	Job Captain Architecture Group Denver Service Center	Will coordinate with furnishings planner on architectural issues such as placement of electrical outlets, HVAC vents, etc.
Name	Interior Designer	Will consult with furnishings planner, museum curator and park staff on choice of furnishings, textiles and wall coverings for conference area.
Name	Historical Architect	Will consult on architectural issues
Name	Chief Ranger	Designated by the superintendent to represents the park in the project
Name	Facilities Manager	Will consult with team members on all facilities-related issues
Name	Fire Protection Engineer	Provides input on fire protection issues
Name	Security Consultant	Consults and provides input on security issues

Project Work Plan

The project curator met with park staff.— The project curator toured the estate, house and collection storage areas, examined the research materials available, and visited nearby family-owned houses to view objects that had once been at the estate.

While at the site, the project curator examined a large collection of historic interior photographs, and identified 150 to be duplicated and sent to her at HFC. Duplication fees are to be paid out of the park project budget. The park curator agreed to pull the photographs and/or negatives and have them reproduced, identified and sent to HFC. The project curator will contact family descendents to determine if they have any papers or objects that should be reviewed for consideration in the planning phase. The curator will travel to one or both locations if necessary to view the objects or materials.

The project curator will make at least one more site visit to record and photograph objects in the collection that could potentially be used in the five historically furnished rooms. The park curator will provide access to the collection and assist project curator with this task.

The project curator will prepare a HFR using all available photographic, documentary, and object evidence. Since the history of the estate has been covered very thoroughly in two HSRs, the management summary, administrative background, history of the structure and historical occupancy sections of the HFR will be brief and will refer to the aforementioned documents. The HFR will contain a list of interpretive objectives, an operating plan, and an evidence section, which will include excerpts from correspondence and the most important historic photographs. The HFR will contain a complete list of furnishings, including all lighting fixtures, for the hall (room XX), the library (room XX), the sitting room (room XX), and bedroom (room XX). The plan will contain recommendations for each of these rooms that will include the following:

- Type of floor covering, such as area rug, oriental carpet, etc.
- Type of wall covering, such as paint, wallpaper
- Type of window covering, such as drapes, roller shades, lace curtains, etc.
- Number and type of large furnishings, including free-standing lighting fixtures, such as five chairs, one drop-leaf table, two table lamps

Recommendations for specific wallpapers, textiles, and furniture will be provided during the production phase of this project, following approval of the HFR. Diagrams indicating the placement of furniture in each of these rooms will be provided.

The project curator will provide the park with two drafts for review and approval before the final HFR is printed. The Historic Furnishings Division will provide the site with five spiral bound, letter size printed reports. Photographs used as illustrations will be reproduced as laser copies in the final report. Fabric samples, wallpaper samples, and furniture samples will be provided to the site during the production phase of the project.

After the completion and approval of the Historic Furnishings Report, the Park may choose to contract with the Historic Furnishings Division, Harpers Ferry Center, to implement the plan. Additional funding will be required at that point to cover the acquisition of objects, wall coverings, and textiles as well as salary and travel. Funding levels will be based on cost estimates provided in the Historic Furnishings Report.

Project Schedule

Begin research	December 2006
Initial site visit and meeting with staff	December 14-16, 2006
First draft of Historic Furnishings Report	June 11, 2007
Comments on first draft due	July 22, 2007
Second draft of Report due	September 2007
Comments on second draft due	October 2007
Five copies of final plan due at site	November 2007

Project Budget

The total project budget for the HFR is \$58,000. This includes all salaries and travel expenses for HFC staff, salary and travel expenses for the interior designer, all research costs, costs of reproducing 150 historic photos and three copies each of two drafts and providing five spiral bound copies of the final report.

Figure 8.4. Annotated Guidelines for Completing Historic Furnishings Reports prepared by Harpers Ferry Center, Department of Planning and Research.

Also see at <http://www.nps.gov/hfc/products/furnish/furnish-plan-hfr-guide.htm>

Table of Contents

Acknowledgments (if appropriate)

Administration

Resource managers find a synopsis of the historic furnishings report (HFR) in the "Administration" section. This synopsis helps managers zero in on issues to consider during review and approval of the HFR itself, and issues that may arise as the plan is implemented at the site. This section briefly addresses:

- how much interior documentation exists for the site
- the plans for furnishings and the basis for those plans
- what other media may be called for in the HFR
- how visitors will experience the site (guided tour, self-guided tour, or some other means)
- how the furnishings plan is tied to a larger restoration package
- what architectural changes may be needed for implementation of the plan.

The "Administration" section of the HFR also explains the management background and history of the site. Other topics usually covered in this section include: the site's enabling legislation and establishment, the status of the site on the National Register and the site's preservation history, the history of use by the National Park Service, and any previous furnishings or other media installations. This section also includes a list of other research and planning documents that pertain to the site, such as general management plans, interpretive prospectuses, historic structure reports, and collection management plans.

- **Interpretive Objectives** – In this subsection, the HFR covers the interpretive objectives of the site's furnished space(s), and addresses the site's general interpretive objectives. Guidelines for personal services interpretation and recommendations for specific interpretive messages that can be conveyed in the furnished spaces are also included here.
- **Operating Plan** – In this subsection, the HFR cites hours and seasons of operation, how visitors access the site (self-guided, guided, fixed-point interpretation, or other), staffing needs for interpretation and maintenance, and a visitor circulation pattern. Barrier needs are discussed here too.

History

This section includes the complete history of the site's interior spaces, their appearance, and how they were used over time. This section's purpose is two-fold: it forms the documentary basis for the furnishings plan and it provides a resource manual for personal services interpretation (and other kinds of interpretive media).

An introductory summary of sources is also included here.

- **History of the Structure** – This subsection of the "History" section includes only a brief discussion of the structure's history, especially if the structural history is conveyed in another document (usually the historic structure report, or HSR). It references any other documents that discuss the structure's history, if such documents exist; otherwise it addresses the structural history only to the extent needed as background for the furnishings history.
- **Historic Occupancy** – This section covers the building's occupants, including household or other staff, as fully as possible (provided this information does not appear in another document), including biographical

information, dates of occupancy, and information about people's lives and activities in the structure. A subsection on room use may be appropriate, particularly if room use changed frequently over time.

- **Evidence of Room Use and Furnishings** – This subsection describes the interior appearance of the structure over time as fully as possible, including the contents of each space and their arrangement, when and where items were acquired and dispensed of, where items were produced, and any known repairs or other kinds of work to the furnishings. It includes interior finishes and lighting fixtures, unless that information is contained in an HSR.

A separate section detailing information on furnishings of closely-related structures is included in the HFR if site-specific information is lacking, and if such information is needed to develop a furnishings plan.

Furnishings Plan

This section guides the furnishings installation and provides a permanent record of object placement for park staff. Some HFRs will be limited to history sections and will not include a furnishings plan.

- **List of Recommended Furnishings** – The furnishings list includes each object's name, documentation or basis for inclusion, park catalog number or, if an object is not in the park collection, whether a reproduction or period piece is needed.
- **Related Media** (if appropriate) – Plans for accompanying media, like panel exhibits, interior wayside exhibits, or other media are included here.

Illustrations

Appendices

Bibliography

Figure 8.5. Determining Costs of Furnishing Historic Interiors, based on a Harpers Ferry Center, Department of Planning and Research Document

To determine the overall cost of a furnishings project, you need to estimate the costs of each phase of the project. These phases include:

- planning
- preparing the HFR
- acquiring historic furnishings
- preparing the interior spaces
- structural repairs and upgrades
- implementation

Historic furnishings costs

The cost for historic furnishings varies. The following variables need to be considered when calculating costs:

- period of interpretation
- quantity of furnishings
- style of furnishings
- cost of collecting original pieces [how collectible they are]
- historical association of original pieces
- number of rooms to be furnished
- cost of acquiring period pieces
- reproduction costs for
 - furnishings
 - floor coverings
 - wall coverings

Planning costs

Planning costs vary less than the cost of production. They are generally in the range of \$40-60,000 per site, depending on the number of rooms to be furnished. Small structures less than 500 square feet are estimated at \$20,000 each.

Production costs

These costs are based on two elements:

- period of interpretation
- condition of original or period furnishings at the site which will be reused in the updated furnishings

Typically, the earlier the period of interpretation, the more expensive the cost of historic furnishings production. There is one notable exception, the very earliest period, 1600-1700. Because of the scarcity of original objects from this period, most furnishings are reproductions rather than antiques. A single estimate, covering all periods, is included for lower cost utility structures such as barns, stables, jail cells etc. A portion of the production funding, usually 10% is allocated for object conservation.

Period of Interpretation	\$ per square foot
Utility structures	\$75.
1600-1700	\$200.
1700-1800	\$375.
1800-1840	\$338.
1840-1870	\$225.
1870-1910	\$225.

1910-1930	\$210.
1930-Present	\$195.

Object preparation costs

Production costs vary based on the condition of the original collection. The following factors apply:

Collection condition	Multiplying factor
Good	0.1
Fair	0.2
Poor	0.8
Outdated	1.0

For example, a 500 square feet project from the period 1840-1870 with an original collection in fair condition would be computed as follows:

$$500 \text{ (square feet)} \times \$225 \text{ (period 1840-1870)} \times .2 \text{ (factor for fair condition)}$$

Total: \$22,500.

Facility costs

HVAC

Fire detection/suppression and intrusion system upgrades

Figure 8.6. Outline of recommended practices for historic furnished interiors adapted from “Standards for Preservation & Guidelines for Preserving Historic Furnished Interiors” of the *National Park Service Northeast Region’s Guidelines for the Treatment of Historic Furnished Interiors*, Northeast Museum Services Center, NPS, with Mid-Atlantic Association of Museums, New York State Office of Parks, Recreation and Historic Preservation, and Pennsylvania Historical and Museum Commission, 2006.

The table of contents below provides an overview of the topics covered in this publication. For detailed information, go to:

http://www.google.com/custom?q=National+Park+Service+Northeast+Region%E2%80%99s+Guidelines+for+the+Treatment+of+Historic+Furnished+Interiors+&sa=Search&client=pub-1415334591037307&forid=1&ie=ISO-8859-1&oe=ISO-8859-1&cof=GALT%3A%230000FF%3BGL%3A1%3BDIV%3A%23FF0000%3BVLC%3A333333%3BAH%3Acenter%3BBGC%3AFFFFF%3BLBGC%3AFFFFF%3BALC%3A0000FF%3BLC%3A0000FF%3BT%3A000000%3BGFNT%3A333333%3BGIMP%3A333333%3BLH%3A39%3BLW%3A100%3BL%3Ahttp%3A%2F%2Fwww.mercuras.com%2Frefdesk_logo_search_LP_v3.gif%3BS%3Ahttp%3A%2F%2Fwww.refdesk.com%3BLP%3A1%3BFORID%3A1%3B&hl=en

Introduction

What is a Historic Furnished Interior?

Character-defining Elements of the Historic Furnished Interior.

Character-defining Features of the Historic Furnished Interior

Preservation Planning and the Research of Historic Furnished Interiors

Some Factors to Consider When Choosing an Appropriate Treatment for the Historic Furnished Interior

Special Requirements: Accessibility Considerations, Energy Efficiency, and Health and Safety Code Considerations

Using the Standards and Guidelines for a Preservation, Rehabilitation, Restoration, or Reconstruction Project.

Standards for Preservation and Guidelines for Preserving Historic Furnished Interiors . Standards for Preservation

Introduction

Identify, Retain, and Preserve Historic Features and Materials

Protect and Stabilize Deteriorated Historic Features and Materials as a Preliminary Measure Maintain Historic Features and Materials

Conserve Historic Features and Materials

Limited Replacement in Kind of Extensively Deteriorated Portions of Historic Architectural Features

Accessibility Considerations, Energy Efficiency, and Health and Safety Code Considerations

Preservation Guidelines

Interior Spaces

Interior Design

Interior Architectural Features and Finishes

Furnishings

Mechanical Systems

Accessibility Considerations, Energy Efficiency, and Health and Safety Code Considerations

Standards for Rehabilitation and Guidelines for Rehabilitating Historic Furnished Interiors

Standards for Rehabilitation

Introduction

Identify, Retain, and Preserve Historic Features and Materials

Protect and Stabilize Deteriorated Historic Features and Materials as a Preliminary Measure . Maintain Historic Features and Materials

Repair and Conserve Historic Features and Materials

Replace Deteriorated Historic Features and Materials

Replace Missing Historic Features and Acquire Replacements for Missing Historic Furnishings
Alterations/Additions for the New Use
Long-term Storage of Removed Features
Accessibility Considerations, Energy Efficiency, and Health and Safety Code Considerations

Rehabilitation Guidelines

Interior Spaces
Interior Design
Interior Architectural Features and Finishes
Furnishings
Mechanical Systems
Accessibility Considerations, Energy Efficiency, and Health and Safety Code Considerations

Restoration Guidelines

Interior Spaces
Interior Design
Interior Architectural Features and Finishes
Furnishings
Mechanical Systems
Accessibility Considerations, Energy Efficiency, and Health and Safety Code Considerations

APPENDIX A: PUBLICATIONS GLOSSARY

- **Bluelines** are photographic versions of printed work made before the works are printed. Bluelines are the final stage of checking the accuracy of a work. They are checked primarily for blemishes, marks, dirt, and illustration placement. Bluelines usually come after page proofs and mechanicals.
- **Boilerplate** is standardized text for repeated use.
- **Browser** refers to a software package used to access the World Wide Web, like Netscape and Internet Explorer.
- **Compression** refers to the process of reducing an image file's size so less storage space is necessary. Compression may be either lossy, where the decompressed document looks different from the original uncompressed image; or lossless, in which it looks identical to the original. With lossy compression, the decompressed image will have artifacts or undesired and unpredictable visual errata. Lossy compression is frequently used for Web derivative copies.
- **Copyediting** refers to the processing of editing a manuscript for the matters listed in *MH-III*, Chapter 3, Publications, Figure 3.9, Museum Management Program Editing Checklist, under Copyediting. This is known also as dry reading, as it refers to checking the text for blatant errors in grammar, punctuation, spelling, word usage, and sentence structure.
- **CD** stands for “compact disc” and refers to a whole family of storage media in a variety of media used for electronic text, digital sound files, digital image and video files, computer software, and games. For further information see Conserve O Gram, 19/19, Care of Archival Compact Discs.
- **Dead copy** (see Dead manuscript).
- **Dead manuscript** refers to the edited final manuscript of a book that is checked against the page proofs.
- **Derivatives** refer to the practice of producing a variety of smaller files from a master digitized file. These smaller, low-resolution files may be “thumbnails,” produced to enhance speedy browsing on the Web. Viewers may often click on the thumbnail to see a larger version of the file. On Kodak CDs, for example, five levels of image quality are stored for each image.
- **Digital image quality** is controlled by various factors, including the scanning device and techniques used, operator skill, the nature and completeness of image labeling, the dynamic range of the scanned image, the scanning resolution, and the final display devices, such as the computer memory, LAN bandwidth, and monitor quality. Quality control is a concern during scanning as alignment, exposures, and color balance frequently go out of control. Scanned images must be regularly checked against original source material and benchmarks (standards) set for scanning projects.
- **Digitalized** (see Digitized).
- **Digitized** describes an image that has been scanned (or created with a digital camera) and converted into binary code (ones and zeros).
- **Dynamic range** refers to the color depth or pixel values of a digital image, usually expressed as the number of colors or shades of gray or the number of bits, for example, 256 color or 8 bits. *Note:* A 24-bit image may have 16 million colors, while an 8-bit image has only 256.

- **Exterior use** refers to the placement of an image, such as quotations or reviews, on the outside or exterior of a publication's cover, advertising, and/or packaging. In a Web environment, this is the top-most Web or homepage.
- **File formats** refers to the digital image data transmission and compression standards used to store the image data. Common standards include GIF and JPEG, described below.
- **Folio** refers to the page number in a manuscript, book, or pamphlet.
- **Font** refers to the combination of the type face of linguistic or numeric characters, such as Times New Roman or Arabic, and the type size, such as 10, 12 or 14 point.
- **GIF, or Graphics Image Format**, refers to a widely used digital image format that serves as a defacto standard.
- **Homepage** is the main or first page of an organization on the World Wide Web. Much like the cover of a book, the homepage's purpose is to lure you into the Web site.
- **HTML** (hypertext mark-up language) is the coding language used to identify, link, and prepare multimedia documents for the World Wide Web. Much like old-fashioned coding of books for publication, html coding indicates the level (size) of the type, where paragraph breaks take place, and other design, word processing, and coding specifications.
- **Indemnification** refers to one party legally exempting another from liability for damages or loss. This includes plagiarism or intellectual property right lawsuit, such as a copyright, privacy, or publicity action.
- **Inner use** refers to the placement of an image or text within the body of a work, such as within the interior of a book, Web site, CD-ROM, or report, as opposed to exterior use, which is on an item's cover, advertising, and/or packaging.
- **Internet** refers to an international network of linked computer networks that emerged out of the Advanced Research Projects Agency (ARPA) of the Defense Department. The Internet forms the backbone of the National Information Infrastructure (NII). The Internet is the home of the World Wide Web (WWW, the graphic portion of the Internet). Many search engines, such as Alta Vista, HotBot, and Yahoo, provide search capabilities for locating items within the Internet.
- **JPEG** refers to the Joint Photographic Experts Group still-image compression standard, which is now a standard image format used on CDs and the World Wide Web sanctioned by the International Standards Organization.
- **Link** is a hypertext code or button that allows two separate sections of text, pages, or Web sites to be connected together. Links are what allow the World Wide Web to become a truly interactive, self-paced, non-linear learning tool. Links allow the browser to move from one topic to another related topic with the click of a mouse. Links enhance the appeal of the Web, by leading to happy accidents of discovery.
- **Live copy** is copy still being edited.
- **Lossless** is a type of compression that causes no image loss or distortion. The original image and the uncompressed copy appear and are identical. Lossless compression doesn't compress as much as lossy compression, only 1/2-1/3 compression generally is possible for continuous tone photographs.
- **Lossy** is a type of image compression that reduces file space needs by discarding part of the information kept. Once uncompressed, lossy images appear somewhat different from the original uncompressed image.
- **Mask** refers to an opaque rectangle with a cut-out that is the size of a single line of copy.

- **Mechanicals** are a middle stage of proofing documents consisting of the publication layout, including type proofs for text, artwork, and other elements exactly positioned and prepared for subsequent production as bluelines.
- **Metadata** refers to data about data, particularly core descriptive data indicating the title, size and format, subject matter, and similar information.
- **Mirror site** refers to a World Wide Web site that is an exact duplicate of another site. Mirror sites are created in other external locales, such as on the server of a cooperating organization, to reduce traffic on the original site. Mirror sites help spread the Web traffic load, speeding access time. Mirror sites can also be created internally within your organization to hold editing changes prior to downloading onto the Web.
- **Orphan** is a short line at the bottom of a page, such as the first line of a new paragraph.
- **Page proofs** (see *Proofs*).
- **Pages** (see *Proofs*).
- **Proofs** refer to the first trial sheets of text produced for checking against the manuscript at the beginning of the end of the publication process. Page proofs contain the manuscript text in oversized typeset pages for review by the author and editor.
- **Proofreading** refers to checking page proofs as described in *MH-III*, Chapter 3, Publications, Figure 3.10, for matters like running heads, page length, missing text, widows and orphans, etc. The author may be asked to review several different sets of proofs. Once corrected, the first set of proofs must be retypeset. The marked up first proofs are called foul proofs. In the second stage of the proofing, the corrected retypeset pages (second proofs) are checked against the errors found on foul proofs. While some new errors may be found on second proofs, the focus of the second proofing is to determine if all corrections were made as requested on the first proofs.
- **Publisher** is one who prepares and issues materials for public distribution or sale in a number of formats, from books, pamphlets, videotapes, and sound recordings to Web sites and CDs.
- **Register** refers to the precise alignment of text from page to page.
- **Repurposing** is reusing materials created for another purpose or project.
- **Resolution**, for images, refers to the number of pixels (picture elements each of which can represent a number of colors or shades depending upon how much computer storage space you allocate to it) that the image is composed of, both in terms of height and width. For output, resolution refers to the number of dots per inch (DPI) used to make up an image on a monitor or in a print out. When contracting, you should define the intended pixel resolution of the scan and the file, as well as the platforms or systems on which it will be used.
- **Search engine** is a software tool used to locate materials on the Internet, much as an index helps a researcher find materials in a book. None of the different search engines searches quite the same components of the Internet or the World Wide Web in quite the same way. The oldest search engines include such programs as Archive (found software and text files accessible by the file transfer protocol), Veronica (indexed gopher server information), Jughead (indexes a single gopher site), and Hytelnet (organizes access to many Internet-connected computer systems and allows remote access to the systems). With the development of the World Wide Web, the Internet's multimedia Internet site, hundreds of more sophisticated search engines came into being, such as Yahoo, Excite, Infoseek, Webcrawler, Alta Vista, All in One, etc. These search engines work differently from each other. For an overview of search engines see: *CRM*, Vol. 18, No. 9, p. 18-24.

- **Substantive editing** requires checking a manuscript's organization, sense, policy, format, style, factual content, and other major issues as described in *MH-III*, Chapter 3, Publications, Figure 3.9, Museum Management Program Editing Checklist. This edit should come before a copyedit, which fine-tunes the style, punctuation, and grammar.
- **TIF** (Tagged Image Interchange File) is an industry-standard format used for storage of images on computer systems.
- **URL** (universal resource locator) is basically the address of a World Wide Web page. The URL is the code you must enter on your Internet service provider's screen to see a World Wide Web site or other Internet site. Most URLs look something like the NPS web site's URL, which is: <www.nps.gov.>

In the URL above, the code indicates the site is on the World Wide Web, belongs to the NPS, and is in the government section of the Web. Other sections or domains include organizations (.org), corporations (.com), education (.edu), which includes colleges and universities, and the military (.net).

- **Watermark** sometimes called digital fingerprint, refers to areas (bits) altered within an image to create a pattern that indicates ownership for purposes of tracing unsanctioned use of the image.
- **Web site** is the total accumulation of pages created by an individual or organization, linked together by hypertext, and mounted as a publication on the World Wide Web. Web sites often are designed to have a consistent visual identity through the use of standard elements at the top and bottom of each page, such as a name or title bar at the top of the page and a button bar at the bottom of the page.
- **Widow** is one line at the top of a page of text, such as the ending of a paragraph.

Appendix D: Guidance on Planning for a Research Space

	<u>Page</u>
A. Research Space Definition and Use D:1	
What is research space?	D:1
Who needs research space?	D:1
Why should my park have a research space?	D:1
What activities should take place in this space?	D:1
B. Research Space Standards D:2	
What are the principal criteria for research spaces?	D:2
C. Security D:2	
What are the security concerns for the collection during research?	D:2
Should the research space have intrusion and fire protection systems?	D:3
How many entrances should the research space have?	D:3
D. Environmental Conditions D:3	
What are the environmental requirements for the research space?	D:3
What temperature and relative humidity levels should be maintained in the research space?	D:3
How do I make available objects that are stored in specialized environments, such as cold storage or low relative humidity conditions?	D:3
What light levels should be maintained?	D:3
E. Space Issues D:4	
How much space do I need for a research space?	D:4
Where should the research space be located?	D:4
F. Researcher Staging Area D:4	
What is a researcher staging area?	D:4
Does my park need a researcher staging area?	D:4
What equipment should I have in the research staging area to serve the needs of researchers?	D:5
G. Equipment for Research Space D:5	
What furniture and equipment should be placed in the research space?	D:5
H. Access for Researchers with Disabilities D:5	
How do I make the research space accessible to persons with disabilities?	D:5
I. Utilities D:6	
What utilities are needed for the research space functions?	D:6
J. Planning for Research Space in a New Facility D:6	
How do I plan for research space in a new facility?	D:6
What can I do if I am forced to reduce space in a new building, and I must combine research space with other functions?	D:6
K. Upgrading Your Facility for Research Space D:6	
How do I plan for research space in an existing facility?	D:6
What if I can't meet some or all of the primary criteria?	D:7
What low-cost immediate improvements can I make if I don't have enough space to make	

separate research, office, curatorial workroom and collection storage spaces?D:7
If research does occur in the storage room or if some objects are stored in the research room,
how can I protect the objects?D:7
What if we have limited staff with curatorial responsibilities and limited resources to supervise
researchers?D:7

B. Using the Research Space D:8

How do I control research space use?.....D:8
How should I monitor the research space?.....D:9

APPENDIX D: GUIDANCE ON PLANNING FOR A RESEARCH SPACE

A. Research Space Definition and Use

1. *What is research space?* A research space is a dedicated workspace within a museum where researchers (both inside and outside the Service) may view and study collections.
2. *Who needs research space?* All parks and centers with museum objects or archival collections need a research space. This guidance will help you plan for a new or upgraded research space.
3. *Why should my park have a research space?* A dedicated research space allows the museum collections to be safely and securely accessed and studied.
4. *What activities should take place in this space?*

Researchers do the following in research spaces:

 - Examine collections.
 - Work with resources available in the research space, including specialized equipment, publications, finding aids, and online computer catalogs.
 - Take notes and write using pencils or computers.
 - Request reference, duplication, and available intellectual property rights management and caption services.
 - Interact with NPS museum collections management staff.
 - Read access policies and procedures and fill out researcher registration forms.

Park and center staff do the following in the research room:

 - Assist researchers. Researchers use many research techniques and methodologies. Be flexible and ready to adapt to the needs of the researcher to the extent that the park can afford to provide your assistance.
 - Monitor and document collections use, particularly for security and preservation concerns.
 - Provide reference, duplication, and available intellectual property rights management and caption services.

- Remove and rehouse materials no longer being used.
-

B. Research Space Standards

1. *What are the principal criteria for research spaces?*

- Dedicate the space to the research function.
- Provide appropriate security for the collection.
- Provide environmental controls adequate to prevent damage to collections.
- Make sure the space is large enough to accommodate the needs and equipment for the number of researchers expected to use the collection.
- Locate the space convenient to staff offices, collection storage space, researcher staging area (see Section F), and curatorial work area and/or laboratory.
- Make space accessible by persons with disabilities.
- Have electrical outlets, phone service with modem or network hookup for accessing Automated National Cataloging System (ANCS+) data, and any other pertinent utilities to meet the needs of the research function and satisfy all applicable electrical codes (both national and local).

C. Security

1. *What are the security concerns for the collection during research?*

Security concerns include researcher and staff theft, malicious vandalism (arson, damaging or destroying objects, etc.), and "censorship" by researchers who deface or destroy documents that they feel reflect negatively upon their town, family, cultural group, etc.

Research space should be observable from staff offices or work areas. Consider the use of a wall with glass windows. For collections with extremely high value, consider the installation of a video-camera monitoring system to continuously view or record researcher use of the collection. Establish procedures to ensure that staff routinely monitor the space and review the video-camera recordings noting irregularities.

Archival/manuscript collections require more stringent measures because they are not cataloged at the item level, so ownership of missing items is more difficult to prove. Make sure users are continuously supervised. You should take limited materials (two boxes at a time) to the research space and monitor researchers while they work and ensure that they work with one document from one folder at a time. See *MH-II*, Appendix D, Museum Archives and Manuscript Collections, Sections T and U.

Some collections may have low inherent risk because they are of low value, commonly available, and have low demand by the general public as collectibles. Collections of high risk include decorative arts, autographed documents, coinage, postage stamps, and firearms because they are generally of high value, significance, and collectibility. See *MH-I*, Chapter 9, Museum Collections Security and Fire Protection, and Appendix G, Museum Collections Protection, for security standards and specifics on performing a risk assessment. See *MH-III*, Chapter I, Evaluating Collections for Access, Sections 5 and 6; and *MH-II*, Appendix D, Museum Archives and Manuscript Collections, Sections T and U for guidance on providing security during reference usage.

2. *Should the research space have intrusion and fire protection systems?* The structure housing the research space should have appropriate intrusion and fire protection/suppression systems as determined by a risk assessment.
3. *How many entrances should the research space have?* The space should have limited entry/exit points—preferably a single door that is a minimum of 36" wide. It may be a double door if larger objects are to be moved in and out.

D. Environmental Conditions

1. *What are the environmental requirements for the research space?* Conditions in the research space should contribute to object preservation. See *MH-I*, Chapter 4, Museum Collections Environment, for standards and guidance on achieving appropriate environmental conditions. Additional guidance on the environmental requirements for specific object types or materials may be found in the appendices of *MH-I* and the *Conserve O Gram* series.
2. *What temperature and relative humidity levels should be maintained in the research space?* Don't subject objects to rapid changes in temperature and relative humidity (RH) when removing them from storage. Temperature and RH in the research space should be kept at the same levels as in collection storage space.
3. *How do I make available objects that are stored in specialized environments, such as cold storage or low relative humidity conditions?* Acclimatize objects stored in specialized cold conditions, such as color and black and white photographic materials, to the conditions of the research space before allowing use. See *MH-I*, Appendix R, Care of Photographic Collections, for guidance on acclimatizing photographic materials. Watch for condensation. You may need to wipe condensation off the housing materials before providing items to researchers.

You may remove metal objects from dry/desiccated conditions (below 35% RH) for short periods of time for research without damage. Be sure to return objects to their specialized storage as soon as possible after use.
4. *What light levels should be maintained?* Maintain light levels that do minimal damage to objects. Lights should be UV filtered to limit damage to light sensitive objects. Sunlight should be excluded from the space. Design the space with no windows. Use coverings that exclude ultraviolet and visible light on existing windows.

Fluorescent lights should have UV filters. Provide additional desktop lights for workspaces with low wattage bulbs. See *MH-I*, Chapter 4, Museum Collection Environment, for more information on proper light levels for specific objects.

E. Space Issues

1. *How much space do I need for a research space?*

The space should accommodate the number of researchers that typically use the collection. Review the history of prior usage. For collections of continuing and high research use, anticipate an annual growth rate for the research space of between 1-10%. The space should be of sufficient size to accommodate the equipment necessary to serve the needs of the researchers for the next 10 years.

Each researcher will need, at a minimum, 9-15 square feet of work surface such as a desk or worktable. The space should be large enough to examine objects, organize work, and read references. Consider the size of objects being researched. More space will be needed to research large, oversized or long objects, such as furnishings, architectural drawings, or long firearms, than would be required for a slide or herbarium collection.

Research space for large, frequently researched collections may occupy as much as 25% of the combined storage and work space (exclusive of exhibition space) in the facility, although it is more common for the research space to take about 10% of the total space in a museum facility.

2. *Where should the research space be located?*

Research space should be adjacent to or close to curatorial offices, collection storage, and curatorial workspace in order to limit the distance objects must travel from one location to the other.

Research on large, heavy, or unwieldy objects, such as architectural fragments or cannons may, with continuous supervision, occur at the location where the objects are stored.

F. Researcher Staging Area

1. *What is a researcher staging area?*

The staging area is used to check, store, and secure the researcher's outer garments, handbags, briefcases, and packages while research is conducted. These items should not be brought into the research space. A staging area should be established outside of, but close to, the research space to accommodate the needs of the researcher.

2. *Does my park need a researcher staging area?*

Yes. Parks with space to establish a staging area should do so. This is particularly important if the collection has frequent research use by many researchers. Parks lacking space to establish a separate staging area should use the curator's office or the curatorial workroom as the staging area.

3. *What equipment should I have in the researcher staging area to serve the needs of researchers?*

Consider providing a hat and coat rack and shelves or lockers for checking, storing, and securing the researcher's outer garments, handbags, briefcases, and packages while research is conducted. Lockers that offer a key in exchange for a coin deposit are very useful. Through signage, indicate that NPS assumes no liability for property left in the staging area.

G. Equipment for Research Space

1. *What furniture and equipment should be placed in the research space?*

Have one or more large work or library tables (36" x 72" to 48 x 96") or sturdy desks (36" x 60") with an appropriate number of chairs. Consider folding tables that can be set up as needed if space is limited. Work surfaces should be clean, washable, stable, well-lighted, and three times larger than the largest materials being researched within the space, so that researchers can work with groups of materials for comparison purposes. You will also need to provide a desk with unrestricted view of the entire space for the research space supervisor.

If applicable, provide a microscope with light source and magnifiers for examining objects and natural history specimens, a computer with access to ANCS+ data, videotape and audiotape playback equipment with earphones, microfilm or microfiche reader, printer, typewriter and TV/VCR. Audio/video equipment are generally not housed in the research space and could be placed on mobile carts for moving in and out of the research room as needed. Also make available (but generally do not keep in the research space) dollies, carts, and book trucks for moving objects.

Include a small reference library with finding aids (never leave the only copies of finding aids in the research space; store additional copies elsewhere), dictionary, ANCS+ manual, *Museum Handbooks*, atlas, encyclopedia, thesaurus, taxonomy books for the types of natural history specimens being studied, archeological references, *Who's Who*-type biographical dictionary, and other standard reference works.

Use a bulletin board to display the policy and use procedures. These policies should also be presented to the researcher to read and sign at the time of registration.

H. Access for Researchers with Disabilities

1. *How do I make the research space accessible to persons with disabilities?*

Access to the research space must meet all requirements as specified in the Americans with Disabilities Act of 1990. Specifically, the space will have:

- passageways a minimum of 36" wide
- doors a minimum of 32" wide

- ramps, if a change in floor level exceeds ½"
- elevators, if the building is multistory
- platform lifts, if the installation of an elevator is impractical

I. Utilities

1. *What utilities are needed for the research space functions?*

Outlets should be provided for task lighting and to run electronic equipment, such as laptop or desk computers. Outlets should be adjacent to the work surface that the researcher uses. Electrical service must meet local and national codes.

Phone service with appropriate jacks should be provided to allow a computer local area network to be established if access to ANCS+ data is to be provided.

Natural history collections research may require a fume hood and sink with running water.

J. Planning for Research Space in a New Facility

1. *How do I plan for research space in a new facility?*

Work with key park, support office, regional, other central office staff (architect, archivist, museum curator, museum specialist), and contractors, who can provide planning assistance.

Define your specific needs. Space must meet the primary criteria indicated above.

2. *What can I do if I am forced to reduce space in a new building, and I must combine research space with other functions?*

Select compatible functions, such as curatorial work space, curatorial staff offices or library reading room that are or can be set up with adequate work surfaces and occupied by staff who can monitor the researcher.

K. Upgrading Your Facility for Research Space

1. *How do I plan for research space in an existing facility?*

Work with park, support office, regional, other central office staff (architect, archivist, museum curator, museum specialist), and contractors, who can examine your particular situation and provide guidance and planning assistance.

Be sure space meets the primary criteria indicated above.

2. *What if I can't meet some or all of the primary criteria?*
- Identify any deficiencies in the Resources Management Plan and NPS Museum Collections Management Checklist (see *MH-I*, Appendix F, Collections Management Checklists) and secure funding to correct those deficiencies. See *MH-I*, Chapter 12, Programming, Funding, and Staffing, for guidance on appropriate procedures, documents, and funding sources.
- Correct deficiencies in stages if many deficiencies need correction or if costs to correct deficiencies are more than amounts funded annually.
3. *What low-cost immediate improvements can I make if I don't have enough space to make separate research, office, curatorial workroom, and collection storage spaces?*
- Consider creating a separate workstation or research space in the curatorial office or workspace.
- Consider sharing research space with related non-museum activities, such as a library reading room, provided the non-museum space is convenient to the museum storage space.
- Consider placing research activities in collection storage space as a last resort if no other space is available and a risk assessment determines the impact on object preservation and security is minimal or can be minimized.
4. *If research does occur in the storage room or if some objects are stored in the research room, how can I protect the objects?*
- Store the collection in locked museum cabinets or in sealed containers on shelving to provide a buffered microenvironment and reduced security risk.
- Create a separate workstation or research space in the storage room, if space allows, by using lumber and wire fencing to form a cage or wire wall to separate the researcher from the collections.
- Continuously monitor all research work conducted in the collection storage space.***
5. *What if we have limited staff with curatorial responsibilities and limited resources to supervise researchers?*
- Have research conducted in spaces constantly occupied by available park staff. Establish procedures and train staff to give attention to the activities of the researcher.
- Allow research only when staff is available. Arrange research appointments at a time when the researcher can be adequately monitored.
- You must allow regular access to collections by the public. Some materials within park collections may be restricted by law or management policies. See *MH-III*, Chapter 1, Evaluating, and Documenting Museum Collections, for further Guidance.

L. Using the Research Space

1. *How do I control research space use?*

Develop policies that guide how the research space operates. These policies should consider:

- staffing levels
- security controls
- the number of research requests you typically receive
- the types of collections that you have

When a researcher first approaches the park, either directly by walking in the door, or by writing, fax, e-mail, or the phone, the researcher should be told the hours and policies of the park for access and use of collections. The researcher should sign and date a form indicating his or her willingness to comply with the policy. (See *MH-II*, Appendix D, Museum Archives and Manuscript Collections, Figure D.13a, Access Policies and Rules Governing Use for a sample of this form.)

Once the researcher appears at the museum or archives to work, he or she should register by filling out a researcher registration form. See *MH-II*, Appendix D, Museum Archives and Manuscript Collections, Figure D.16 for a sample Researcher Registration Form. **Note:** Supervisory research space staff should record identification numbers from picture identification, such as drivers licenses and work cards on the researcher registration form and should also check to ensure that the address and phone number listed on the form matches any given on the identification card.

The researcher should be escorted to the research space, stopping in the staging area to store coats, purses, bags, or briefcases or other containers, which should not be brought into the research space. Then proceed to the research space where the research space supervisor explains

- access policies
- handling policies (For more information, see *MH-I*, Chapter 6, Handling, Packing and Shipping, and *Conserve O Grams* 8/2, Storing and Handling Plaster Objects; 14/4, Caring for Photographs: General Guidelines; 19/3, Use and Handling of Rare Books; and 19/17, Handling Archival and Paper-based Materials.)
- duplication policies (See *MH-II*, Appendix D, Museum Archives and Manuscript Collections, Figures D.14 and D.15.)

Remember to only allow copying of material that is in the public domain. (See *MH-III*, Chapter 2, Legal Issues.)

Note: See *MH-II*, Appendix D, Museum Archives and Manuscript Collections, Section U, for guidance on implementing access and usage

policies.

When a researcher first enters the research space, you should acquaint him or her with available equipment and reference materials including the park guide, finding aids, and ANCS+ for research purposes. If appropriate, provide cotton gloves and pencils for researcher use. Once a researcher requests specific objects from the museum collection or boxes of an archival collection for viewing the park staff should:

- Record all collections requested or used by the researcher on the registration form.
- Record all reproductions requested on the duplication form. See *MH-II*, Appendix D, Museum Archives and Manuscript Collections, Figure D.14, Researcher Duplication Form. The researcher must also read, sign and date the copyright and privacy restrictions form. See *MH-II*, Appendix D, Museum Archives and Manuscript Collections, Figure D.15 for a sample form.

Once an item is provided to a researcher for viewing, you should record the museum object catalog number or archival box number on the researcher registration form. Once viewed, you should remove the materials from the research room.

2. *How should I monitor the research space?*

Seat the researcher facing you. Don't allow an obstruction to occur between you and the researcher, such as internal columns, furniture, or piled boxes of research materials. If necessary install convex security mirrors, so that you can see around any potential obstructions. Don't pile boxes on the worktable; place the objects or boxes of records to be viewed on a cart alongside.

While the installation of convex security mirrors and wall-mounted video security cameras can help deter theft and vandalism by some, ***only careful research space monitoring can stop theft, vandalism, and mishandling as it occurs.*** By watching researchers you can avoid serious damage to your collections.

When monitoring the research space, be aware of sounds, as well as sights. Check researchers regularly to see if they are handling materials correctly or seem to be having problems. Tactfully show researchers who are handling materials improperly a better method. Remind researcher not to rearrange archival items within the storage box or folders.

A thief can cut plates from a rare book in a few seconds and secret them in a notepad to transfer them into a briefcase. Unbound archival materials and small objects, such as jewelry or tools, are even easier to steal. They fit easily into a pocket or in a sack under a loose jacket. If you have a very busy research space, you may have to give it your full and continuous attention, moving your eyes throughout all areas where people are working to see if anything looks out of place or improper. You don't have to watch a single researcher by staring at him or her continuously. Instead, you should focus on determining what a researcher is doing every 30 seconds or so. Don't just look up and down quickly; ***pay attention.*** Try not to be predictable in your monitoring pattern.

Remember that there is a significant market for museum and archival materials. Another common problem is scholars or family members who feel strongly about the image of their ancestor or subject. Some individuals have edited, marked up, ripped, torn, or destroyed documents to which they objected. Be alert to any sign that may indicate missing, damaged, or vandalized materials—such as stubs of cut-off pages. For instructions on dealing with research space theft, see *MH-III*, Chapter 1, Evaluating and Documenting Museum Collections Use, Section G, Preservation and Protection.

If you must leave the research space, get someone trained in monitoring researchers to replace you. This may mean you must have several people on hand to provide back-up support. If you find yourself totally distracted by one researcher, call another staff member to help you monitor the room or ask the distracting individual to talk with you about his or her topic at another, less busy time.

If no staff is available for research space monitoring, the research space should be closed and locked and all materials returned to storage.